

# **INNOLUX DISPLAY CORPORATION**

## **MT220WW01 V.7 LCD MODULE SPECIFICATION**

( ) Preliminary Specification

(●) Final Specification

<i>Approved by</i>	<i>Checked by</i>	<i>Prepared by</i>
<a href="http://www.jxlcd.com">www.jxlcd.com</a>		

**Innolux Display Corporation,**

No.160 Kesyue Rd., Chu-Nan Site, Hsinchu Science Park,

Chu-Nan 350, Miao-Li County, Taiwan

Tel: 886-37-586000

Fax: 886-37-586060

**Document Number: MT220WW01 V.7-DR4-26**

# **INNOLUX** DISPLAY CORPORATION

## MT220WW01 V.7 LCD MODULE SPECIFICATION

Department		Prepared by	Checked by
MKT			
PD	EE <a href="http://www.jxlcd.com">www.jxlcd.com</a> ME		
TD			
RA			

Innolux Display Corporation

Document Number: MT220WW01 V.7-DR4-26



<b>Contents:</b>	
<b>A. General Specification</b>	
<b>B. Electrical Specifications</b>	
1. Pin assignment	
2. Absolute maximum ratings	
3. Electrical characteristics	
a. Typical operating conditions	
b. Display color vs. input data signals	
c. Input signal timing	
d. Display position	
e. Backlight Unit	
<b>C. Optical specifications</b>	
<b>D. Reliability test items</b>	
<b>E. Safety</b>	
<b>F. Display quality</b>	
<b>G. Handling precaution</b>	
<b>H. Label</b>	
<b>I. Mechanical drawings</b>	
<b>Appendix</b>	



**A. General Specification**

NO.	Item	Specification	Remark
1	Display resolution (pixel)	1680(H) X 1050(V), WSXGA+ resolution	
2	Active area (mm)	473.76(H) X 296.1(V)	
3	Screen size (inch)	22 inches diagonal	
4	Pixel pitch (mm)	0.282(H) X 0.282(V)	
5	Color configuration	R, G, B vertical stripe	
6	Overall dimension (mm)	493.7 (W) X 320.1 (H) X 9.8 (D) (Typ.)	
7	Weight (g)	1800 (max.)	
8	Surface treatment	Anti-glare, Haze = 25%, Hard coating (3H)	Note 1
9	Input color signal	8 bit LVDS	
10	Display colors	16.7 M (6 bit with Hi-FRC)	
11	Color saturation	70% NTSC	
12	Optimum viewing direction	6 o'clock	
13	Backlight	Side-light bar (White LED)	
14	RoHS	RoHS compliance	
15	Halogen Free	Halogen free compliance	
16	TCO 5.0	TCO 5.0 compliance	Note 2

Note 1: Glare Option available

Note 2: Only Anti-Glare can meet TCO 5.0.

## B. Electrical Specifications

### 1. Pin assignment

#### 1.1. TFT panel Connector

Foxconn GS23302-0011R-7F or mechanical interface equivalent connector.

Pin No.	Symbol	Description
Frame	VSS	Ground
1	RXinO0-	-LVDS differential data input, Chan 0-Odd
2	RXinO0+	+LVDS differential data input, Chan 0-Odd
3	RXinO1-	-LVDS differential data input, Chan 1-Odd
4	RXinO1+	+LVDS differential data input, Chan 1-Odd
5	RXinO2-	-LVDS differential data input, Chan 2-Odd
6	RXinO2+	+LVDS differential data input, Chan 2-Odd
7	VSS	Ground
8	RXOC-	-LVDS differential Clock input (Odd)
9	RXOC+	+LVDS differential Clock input (Odd)
10	RXinO3-	-LVDS differential data input, Chan 3-Odd
11	RXinO3+	+LVDS differential data input, Chan 3-Odd
12	RXinE0-	-LVDS differential data input, Chan 0-Even
13	RXinE0+	+LVDS differential data input, Chan 0-Even
14	VSS	Ground
15	RXinE1-	-LVDS differential data input, Chan 1-Even
16	RXinE1+	+LVDS differential data input, Chan 1-Even
17	VSS	Ground
18	RXinE2-	-LVDS differential data input, Chan 2-Even
19	RXinE2+	+LVDS differential data input, Chan 2-Even
20	RXEC-	-LVDS differential Clock input (Even)
21	RXEC+	+LVDS differential Clock input (Even)
22	RXinE3-	-LVDS differential data input, Chan 3-Even
23	RXinE3+	+LVDS differential data input, Chan 3-Even
24	VSS	Ground
25	VSS	Ground
26	NC	No Connection
27	VSS	Ground
28	VCC	+5.0V power supply
29	VCC	+5.0V power supply
30	VCC	+5.0V power supply
Frame	VSS	Ground

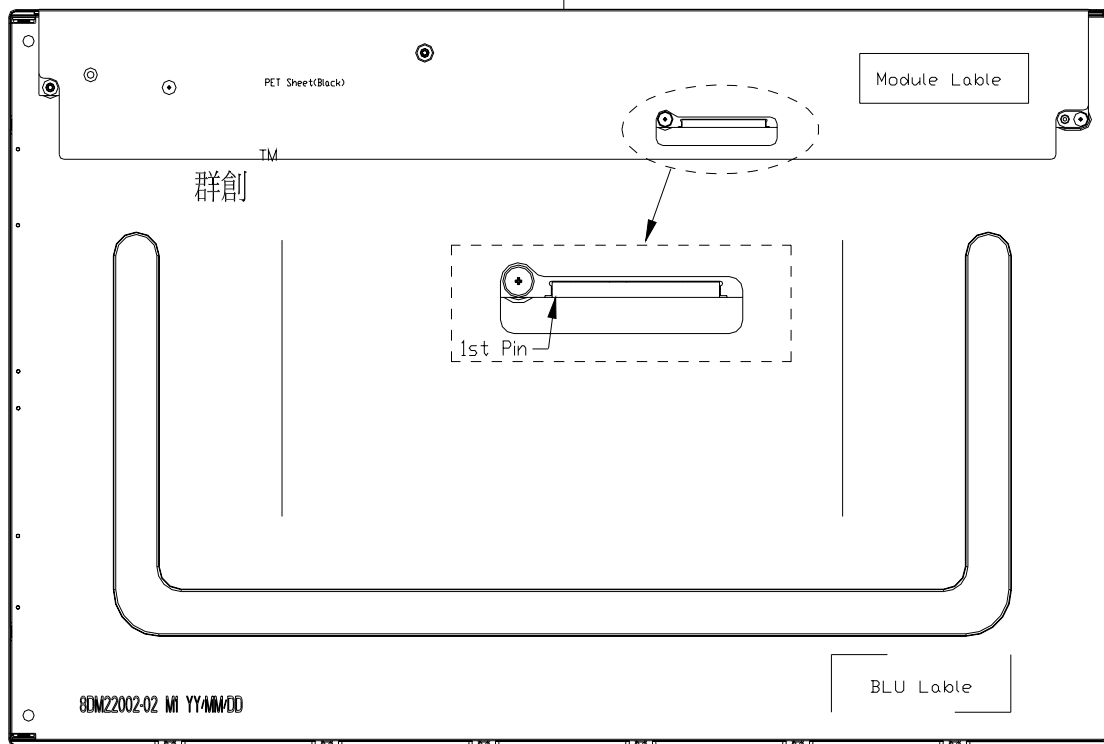

Rear View of LCM

[www.jxlcd.com](http://www.jxlcd.com)

1.2. Recommend Connector for Backlight Unit

This connector is mounted on the monitor system board for LED light-bar FFC mating.

Connector Name/Designation	Match Connector
Manufacturer	Entery INDUSTRIAL CO.,LTD
Mating type part number	7080-Q10N-00R

1.3 Light-bar Connector Pin Assignment

Upper Light-bar Connector Pin Assignment:

Pin No	Symbol	Description
1	IRLED1	LED current sense for string 1
2	IRLED1	LED current sense for string 1
3	IRLED2	LED current sense for string 2
4	VLED	LED power supply
5	VLED	LED power supply
6	VLED	LED power supply
7	VLED	LED power supply
8	IRLED2	LED current sense for string 2
9	IRLED3	LED current sense for string 3
10	IRLED3	LED current sense for string 3

Lower Light-bar Connector Pin Assignment:

Pin No	Symbol	Description
1	IRLED1	LED current sense for string 1
2	IRLED1	LED current sense for string 1
3	IRLED2	LED current sense for string 2
4	VLED	LED power supply
5	VLED	LED power supply
6	VLED	LED power supply
7	VLED	LED power supply
8	IRLED2	LED current sense for string 2
9	IRLED3	LED current sense for string 3
10	IRLED3	LED current sense for string 3

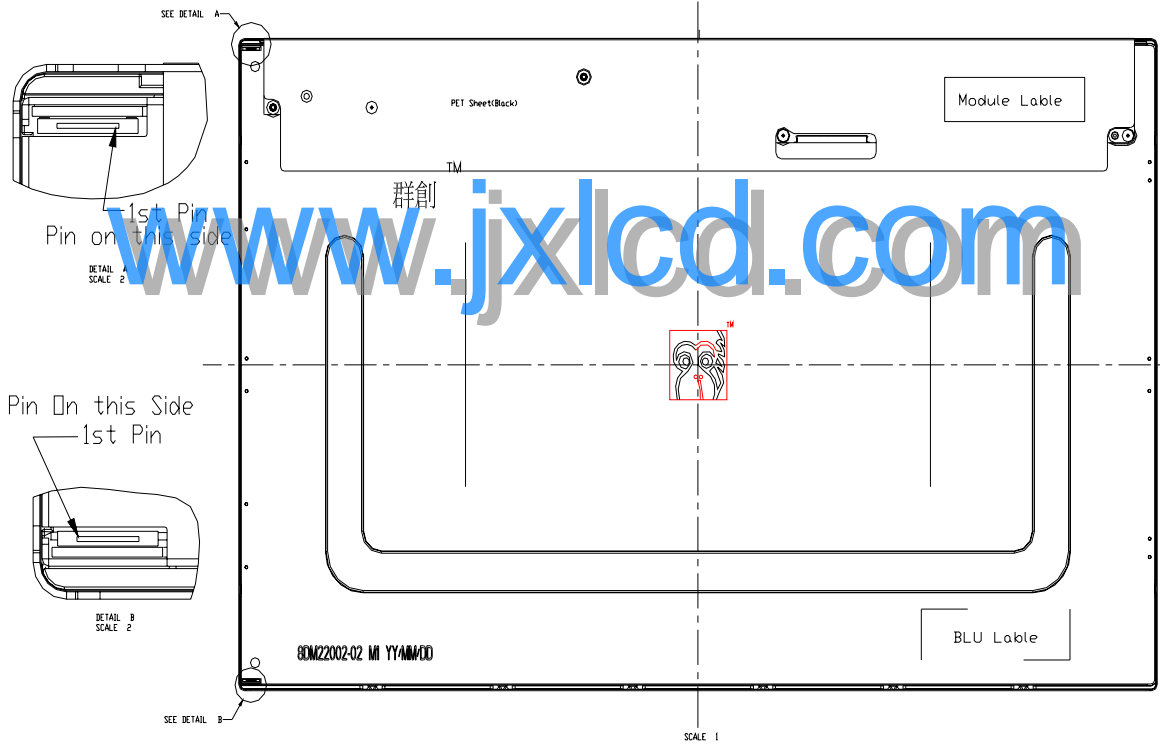

Rear View of LCM



2. Absolute maximum ratings

Parameter	Symbol	Values		Unit	Remark
		Min.	Max.		
Power voltage	$V_{cc}$	-0.3	6.0	V	At 25°C
Input signal voltage	$V_{LH}$	-0.3	4.3	V	At 25°C
Operating temperature	Top	0	50	°C	Note 1
Storage temperature	$T_{ST}$	- 20	60	°C	Note 2

Note 1: The relative humidity must not exceed 90% non-condensing at temperatures of 40°C or less. At temperatures greater than 40°C, the wet bulb temperature must not exceed 39°C.

Note 2: The unit should not be exposed to corrosive chemicals.

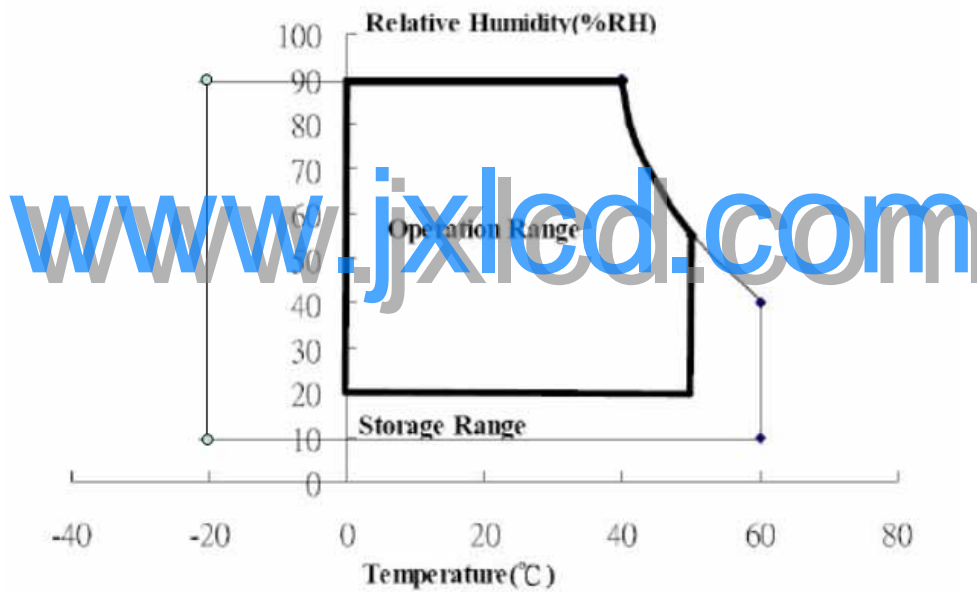

## 3. Electrical characteristics

## a. Typical operating conditions

Item		Symbol	Min.	Typ.	Max.	Unit	Remark
Input Voltage		$V_{cc}$	4.5	5	5.5	V	
Permissive Power Input Ripple		$V_{RF}$	-	-	0.25	V	
Input Current	Black	$I_{cc}$	-	900	1400	mA	Note 1
	White	$I_{cc}$	-	700	-		Note 2
	Mosaic	$I_{cc}$	-	800	-		Note 3
Rush Current		$I_{Rush}$	-	-	4	A	Note 4
Logic Input	Common Mode Voltage	VCM	-	1.2	-	V	
Voltage LVDS:	Differential Input Voltage	VID	100	-	600	mV	
	Threshold Voltage (High)	VTH	-	-	100	mV	Note 5
IN+, IN-	Threshold Voltage (Low)	VTL	-100	-	-	mV	Note 5

Note 1 : The specified current is under the  $V_{cc} = 5V$ ,  $25^{\circ}C$ ,  $fv=60Hz$  (frame frequency) condition whereas black pattern is displayed.

Note 2 : The specified current is under the  $V_{cc} = 5V$ ,  $25^{\circ}C$ ,  $fv=60Hz$  (frame frequency) condition whereas white pattern is displayed.

Note 3 : The specified current is under the  $V_{cc} = 5V$ ,  $25^{\circ}C$ ,  $fv=60Hz$  (frame frequency) condition whereas mosaic pattern(black & white [8\*6] ) is displayed.

White : 255 Gray

Black : 0 Gray

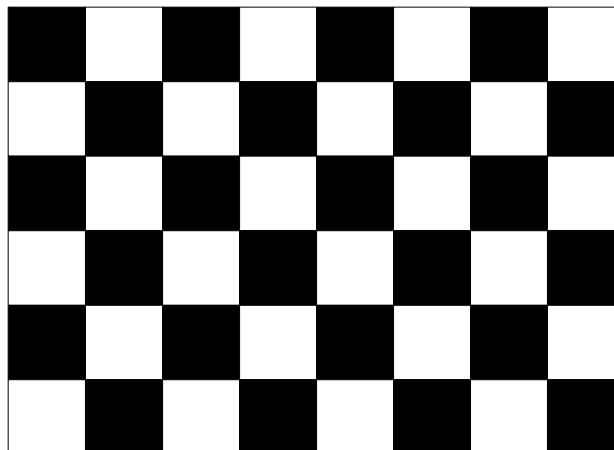

Note 4 : test condition :

- (1)  $V_{DD} = 5\text{ V}$ ,  $V_{DD}$  rising time =  $470\ \mu\text{s} \pm 10\%$
- (2) Pattern: Mosaic pattern

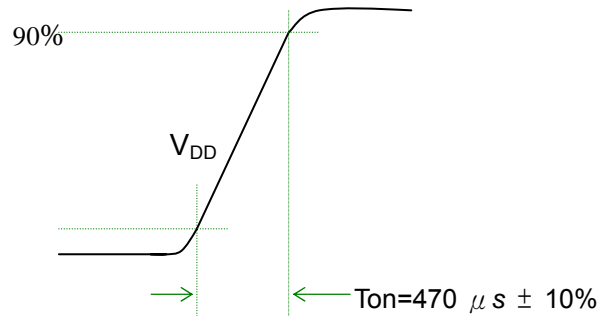

(3) Test circuit

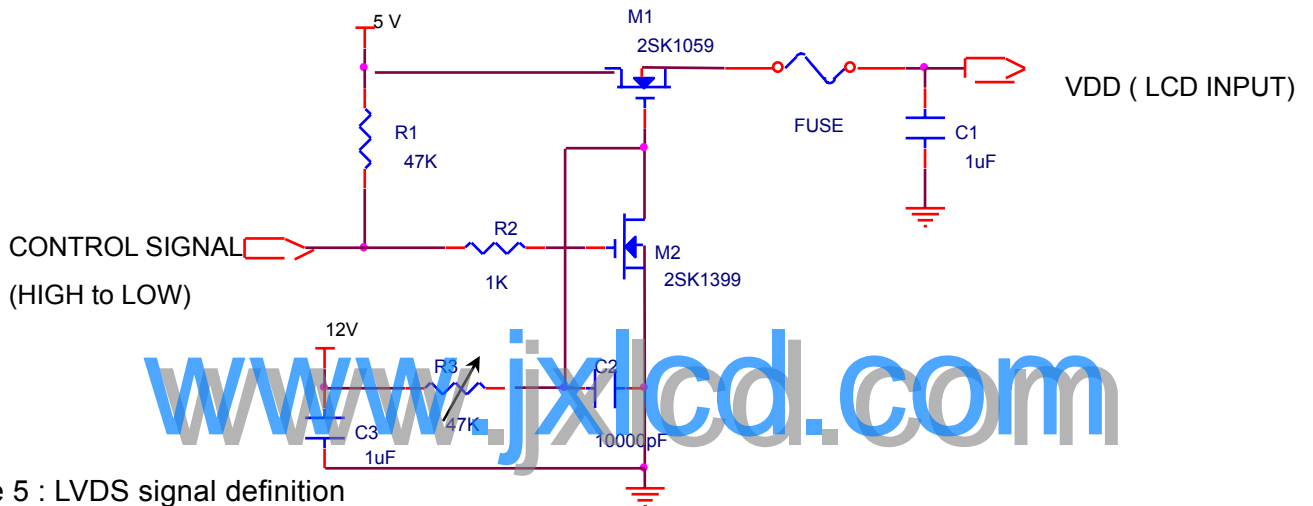

Note 5 : LVDS signal definition

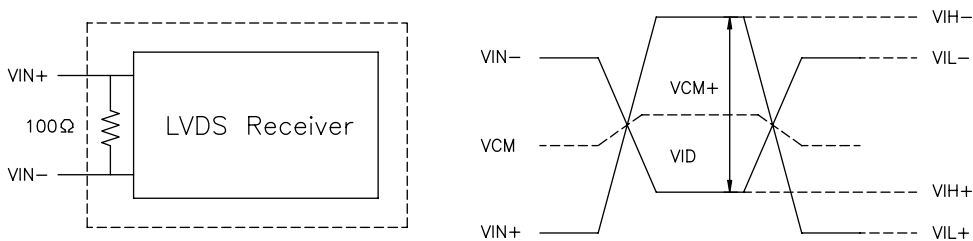

- $VIN+$  = Positive differential DATA & CLK Input
- $VIN-$  = Negative differential DATA & CLK Input
- $VID = VIN+ - VIN-$  ,
- $\Delta VCM = | VCM+ - VCM- |$  ,
- $\Delta VID = | VID+ - VID- |$  ,
- $VID+ = | VIH+ - VIH- |$  ,
- $VID- = | VIL+ - VIL- |$  ,
- $VCM = (VIN+ + VIN-)/2$ ,
- $VCM+ = (VIH+ + VIH-)/2$ ,
- $VCM- = (VIL+ + VIL-)/2$ ,

Note 6 : Power on sequence for LCD V<sub>DD</sub>

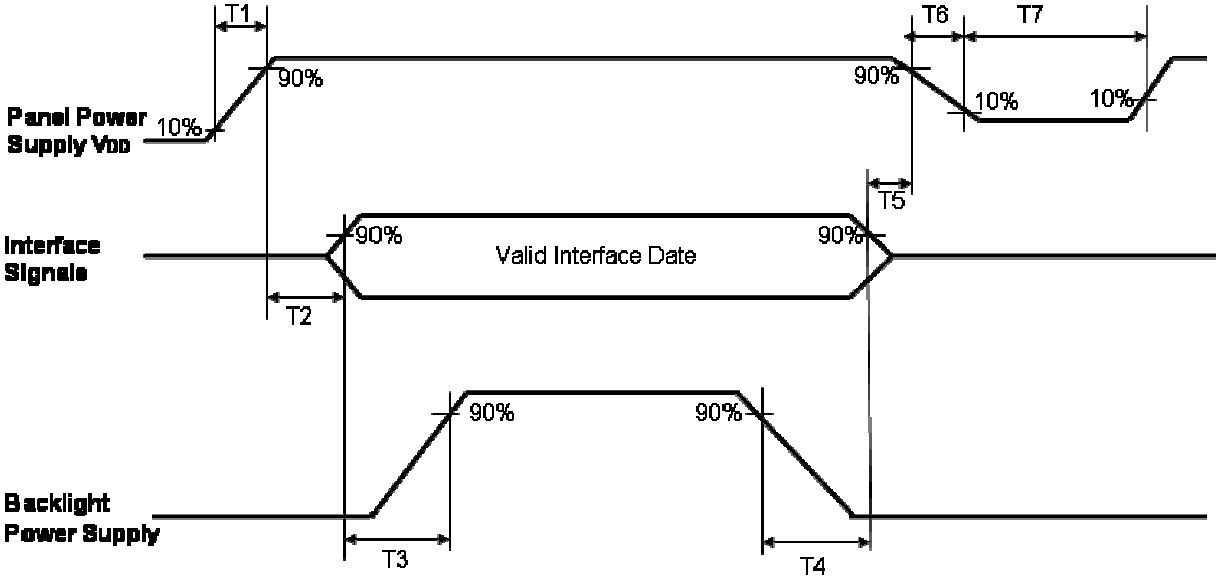

Parameter	Value			Unit
	Min.	Typ.	Max.	
T1	0.1		10	ms
T2	0		50	ms
T3	200	250	--	ms
T4	100	250	--	ms
T5	0	20	50	ms
T6	0.1	--	10	ms
T7	1000	--	--	ms

b. Display color vs. input data signals

The brightness of each primary color (red, green and blue) is based on the 8-bit gray scale data input for the color; the higher the binary input, the brighter the color. The table below provides a reference for color versus data input.

Color	Input color data																							
	Red								Green								Blue							
	MSB				LSB				MSB				LSB				MSB				LSB			
	R7	R6	R5	R4	R3	R2	R1	R0	G7	G6	G5	G4	G3	G2	G1	G0	B7	B6	B5	B4	B3	B2	B1	B0
Basic colors	Black	0	0	0	0	0	0	0	0	0	0	0	0	0	0	0	0	0	0	0	0	0	0	0
	Red(255)	1	1	1	1	1	1	1	0	0	0	0	0	0	0	0	0	0	0	0	0	0	0	0
	Green(255)	0	0	0	0	0	0	0	0	1	1	1	1	1	1	1	0	0	0	0	0	0	0	0
	Blue(255)	0	0	0	0	0	0	0	0	0	0	0	0	0	0	0	1	1	1	1	1	1	1	1
	Cyan	0	0	0	0	0	0	0	0	1	1	1	1	1	1	1	1	1	1	1	1	1	1	1
	Magenta	1	1	1	1	1	1	1	0	0	0	0	0	0	0	0	1	1	1	1	1	1	1	1
	Yellow	1	1	1	1	1	1	1	1	1	1	1	1	1	1	0	0	0	0	0	0	0	0	0
	White	1	1	1	1	1	1	1	1	1	1	1	1	1	1	1	1	1	1	1	1	1	1	1
Red	Red(000) dark	0	0	0	0	0	0	0	0	0	0	0	0	0	0	0	0	0	0	0	0	0	0	
	Red(001)	0	0	0	0	0	0	1	0	0	0	0	0	0	0	0	0	0	0	0	0	0	0	
	Red(002)	0	0	0	0	0	0	1	0	0	0	0	0	0	0	0	0	0	0	0	0	0	0	
	:	:	:	:	:	:	:	:	:	:	:	:	:	:	:	:	:	:	:	:	:	:	:	
	Red(253)	1	1	1	1	1	1	0	1	0	0	0	0	0	0	0	0	0	0	0	0	0	0	
	Red(254)	1	1	1	1	1	1	0	0	0	0	0	0	0	0	0	0	0	0	0	0	0	0	
	Red(255) bright	1	1	1	1	1	1	1	0	0	0	0	0	0	0	0	0	0	0	0	0	0	0	
Green	Green(000) dark	0	0	0	0	0	0	0	0	0	0	0	0	0	0	0	0	0	0	0	0	0	0	
	Green(001)	0	0	0	0	0	0	0	0	0	0	0	0	0	0	1	0	0	0	0	0	0	0	
	Green(002)	0	0	0	0	0	0	0	0	0	0	0	0	0	1	0	0	0	0	0	0	0	0	
	:	:	:	:	:	:	:	:	:	:	:	:	:	:	:	:	:	:	:	:	:	:	:	
	Green(253)	0	0	0	0	0	0	0	0	1	1	1	1	1	1	0	1	0	0	0	0	0	0	
	Green(254)	0	0	0	0	0	0	0	0	1	1	1	1	1	1	1	0	0	0	0	0	0	0	
	Green(255) bright	0	0	0	0	0	0	0	0	1	1	1	1	1	1	1	0	0	0	0	0	0	0	
Blue	Blue(000) dark	0	0	0	0	0	0	0	0	0	0	0	0	0	0	0	0	0	0	0	0	0	0	
	Blue(001)	0	0	0	0	0	0	0	0	0	0	0	0	0	0	0	0	0	0	0	0	0	1	
	Blue(002)	0	0	0	0	0	0	0	0	0	0	0	0	0	0	0	0	0	0	0	0	0	1	
	:	:	:	:	:	:	:	:	:	:	:	:	:	:	:	:	:	:	:	:	:	:	:	
	Blue(253)	0	0	0	0	0	0	0	0	0	0	0	0	0	0	0	1	1	1	1	1	1	0	
	Blue(254)	0	0	0	0	0	0	0	0	0	0	0	0	0	0	0	1	1	1	1	1	1	0	
	Blue(255) bright	0	0	0	0	0	0	0	0	0	0	0	0	0	0	0	1	1	1	1	1	1	1	

c. Input signal timing

Support Input Timing Table

The input signal timing specifications are shown as the following table and timing diagram.

Signal	Item	Description	Min.	Typ.	Max.	Unit
Clock	Dclk	period	12.2	16.8	21.23	nS
		frequency	47.1	59.6	82	MHz
Vertical	$T_{V\_TOTAL}$	V total line number	1059	1080	1100	$T_H$
	$T_{V\_DATA}$	Data duration	1050	1050	1050	$T_H$
	$T_{VB}$	V-blank	9	30	50	$T_H$
	$f_V$	frequency	50	60	76	Hz
Horizontal	$T_{H\_TOTAL}$	H total pixel number	890	920	1004	DCIk
	$T_{H\_DATA}$	Data duration	840	840	840	DCIk
	$T_{HB}$	H-blank	73	80	164	DCIk

Note: Because this module is operated by DE only mode, Hsync and Vsync input signals should be set to low logic level or ground. Otherwise, this module would operate abnormally.

**INPUT SIGNAL TIMING DIAGRAM**

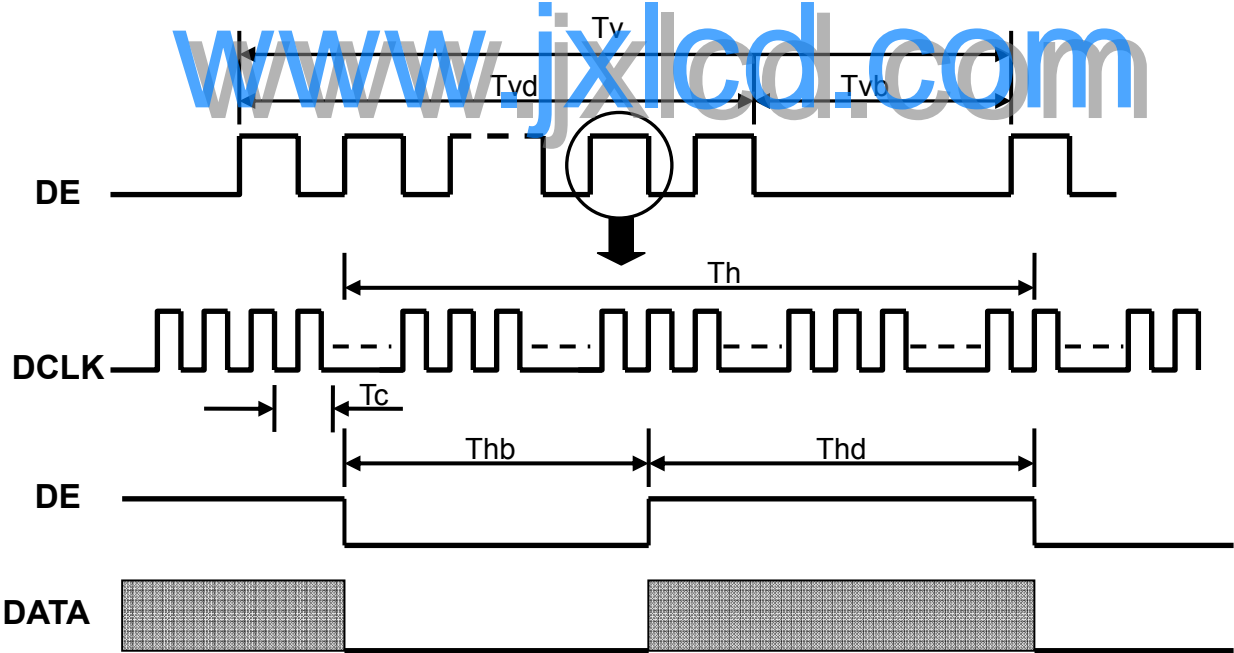

## d. Display Position

D(1, 1)	D(2, 1)	.....	D(840, 1)	.....	D(1679, 1)	D(1680, 1)
D(1, 2)	D(2, 2)	.....	D(840, 2)	.....	D(1679, 2)	D(1680, 2)
⋮		.....	⋮	.....	⋮	⋮
D(1, 525)	D(2, 525)	.....	D(840, 525)	.....	D(1679, 525)	D(1680, 525)
⋮		.....	⋮	.....	⋮	⋮
D(1, 1049)	D(2, 1049)	.....	D(840, 1049)	.....	D(1679, 1049)	D(1680, 1049)
D(1, 1050)	D(2, 1050)	.....	D(840, 1050)	.....	D(1679, 1050)	D(1680, 1050)

## e. Backlight Unit

Parameter	Symbol	Value			Unit	Note
		Min.	Typ.	Max.		
Light Bar Input Voltage	VLED	-	42.9	44.2	VDC	(Duty 100%)
Light Bar Input Current	ILED	-	-	360	mADC	1,2,3
Power Consumption	PLED	-	-	15.91	Watt	4
LED Life Time	LBL	-	30000	-	Hrs	5

Note 1: There are two Light Bars, and the specified current is input LED chip 100% duty current.

Note 2: The sensing current of each string is 60mA.

Note 3: Each light bar have three current sensing strings, so that each light bar input current is 180mA.

Note 4:  $P_{LED} = I_{LED} \times V_{LED}$ .

Note 5: The life time is determined as the time at which luminance of the LED becomes 50% of the initial brightness or not normal lighting at  $I_{LED}=360mA$  on condition of continuous operating at  $25\pm 2^{\circ}C$ .

**C. Optical Specifications**

Item	Symbol	Condition	Specification			Unit	Remark
			Min.	Typ.	Max.		
Response time	Tr	$\theta = 0^\circ$		1.5	3	ms	Note 2
	Tf			3.5	7		
	Tr+Tf			5	10		
Contrast ratio	CR	$\theta = 0^\circ$	700	1000			Note 1,3
Viewing angle	Top	$CR \geq 10$	70	80		deg.	Note 1,3,5
	Bottom	$CR \geq 10$	70	80			
	Left	$CR \geq 10$	75	85			
	Right	$CR \geq 10$	75	85			
Brightness (Center)	YL		200	250		nit	Note 1,4,8
Color chromaticity (CIE)	Wx	$\theta = 0^\circ$	-0.03	0.313	+0.03		Note 1
	Wy			0.329			
	Rx			0.640			
	Ry			0.345			
	Gx			0.324			
	Gy			0.619			
	Bx			0.150			
	By			0.059			
White uniformity (9 points)	$\delta w$		0.70	0.75			Note 1,6
Cross talk	Ct				1.5%		Note 7

Note : Ambient temperature = 25°C.

To be measured in dark room after backlight warm up 10 minutes.

Note 1: To be measured with a viewing cone of 2° by Topcon luminance meter BM-5A.

Note 2: Definition of response time:

The output signals of BM-7 are measured when the input signals are changed from "Black" to "White" (falling time) and from "White" to "Black" (rising time), respectively. The response time interval is between the 10% and 90% of amplitudes. Refer to figure as below :



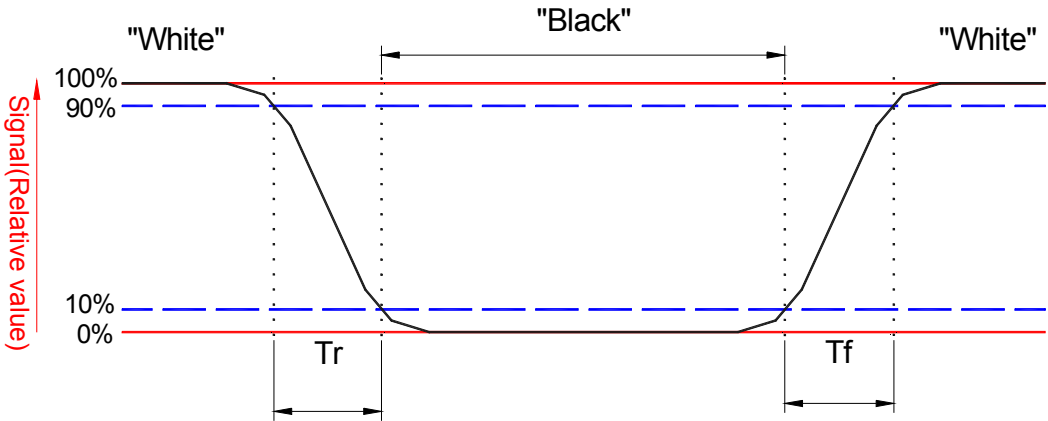

Note 3: Definition of contrast ratio:

Contrast ratio is calculated by the following formula.

$$\text{Contrast ratio (CR)} = \frac{\text{Brightness on the "white" state}}{\text{Brightness on the "black" state}}$$

Note 4: Driving conditions for LED Light Bar:  $I_{LED}=360\text{mA}$

Note 5: Definition of viewing angle.

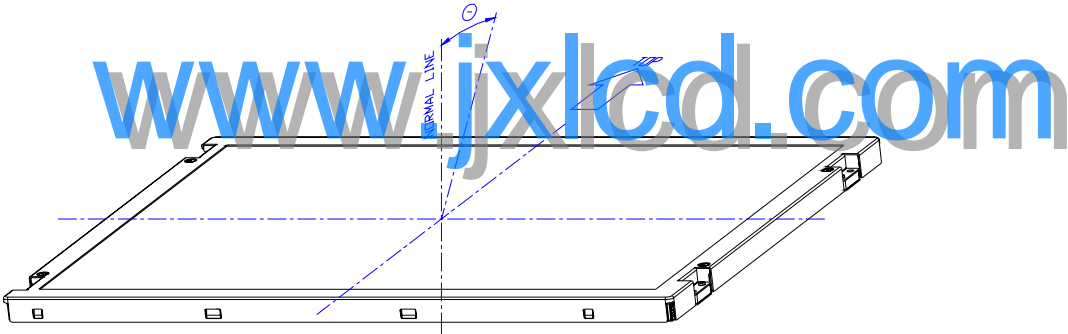

Note 6: Definition white uniformity:

Luminance are measured at the following nine points (P1~P9).

$$\delta_w = \frac{\text{Minimum Brightness of nine points (P1~P9)}}{\text{Maximum Brightness of nine points (P1~P9)}}$$

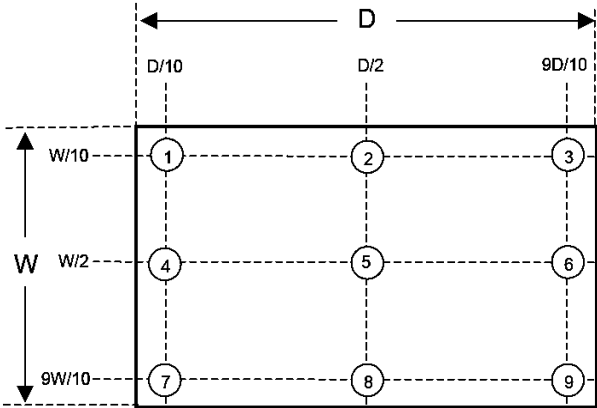

Note 7:

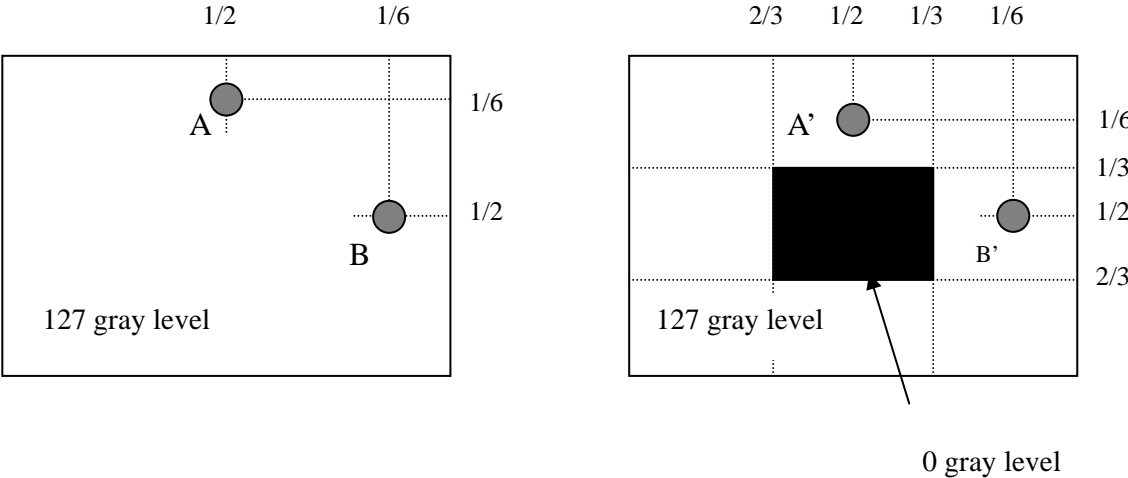

$|L_A - L_{A'}| / L_A \times 100\% = 1.5\% \text{ max.}$ ,  $L_A$  and  $L_{A'}$  are brightness at location A and A'  
 $|L_B - L_{B'}| / L_B \times 100\% = 1.5\% \text{ max.}$ ,  $L_B$  and  $L_{B'}$  are brightness at location B and B'

Note 8: Optical characteristic measurement setup.

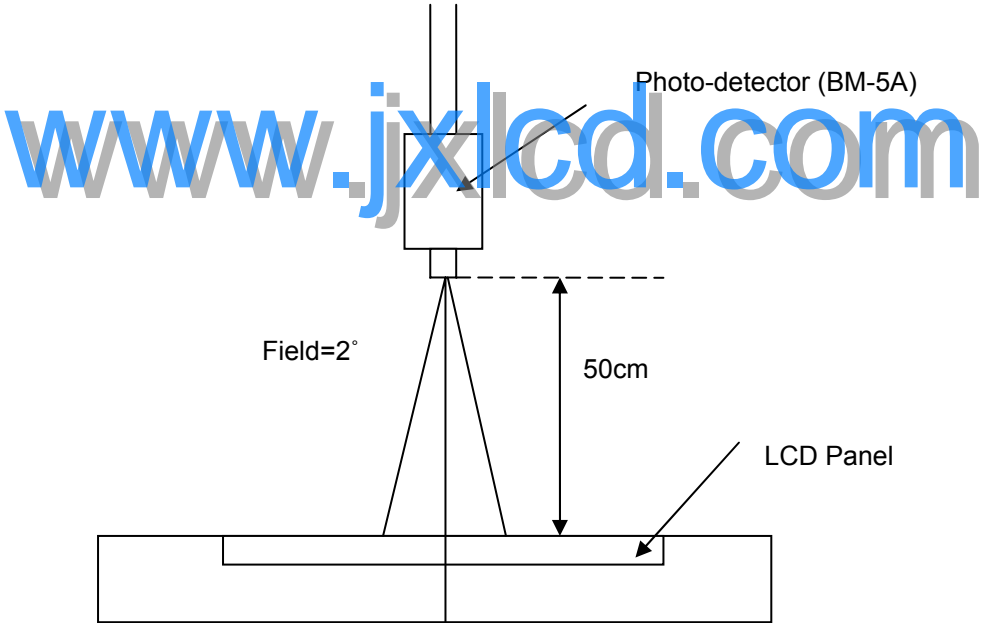

**D. Reliability test items**

Test Item	Test Condition	Judgment	Remark
High temperature storage	60°C, 240Hrs	Note 1	Note 2
Low temperature storage	-20°C, 240Hrs	Note 1	Note 2
High temperature & high humidity operation	40°C, 90%RH, 240Hrs (No condensation)	Note 1	Note 2
High temperature operation	50°C, 240Hrs	Note 1	Note 2
Low temperature operation	0°C, 240Hrs	Note 1	Note 2
Thermal Shock (non-operation)	-20°C~60°C -20°C /1Hr, 60°C /1Hr, 100cycles	Note 1	Note 2
Electrostatic discharge (ESD) (non-operation)	Contact: +/-8kV, 150pF(330ohms), 10 times/1 point, 1 time/1 sec, total 16 points Air discharge: +/-15kV, 150pF(330ohms), 10 times/1 point, 1 time/1 sec, total 9 points time/1 sec, total 9 points	Note 1	Note 2
Vibration (non-operation)	Vibration level : 1.5G Bandwidth : 10-300 Hz Waveform : sine wave sweep rate : 10min 30 min for each direction X, Y, Z (1.5 Hrs in total)	Note 1	Note 2
Mechanical Shock (non-operation)	Shock level : 50G, 11ms Waveform : Half sine wave Direction : ±X, ±Y, ±Z One time each direction	Note 1	Note 2
MTBF Demonstration	30,000 hours with confidence level 90%	Note 1	Note 3

Note1: Pass: Normal display image with no obvious non-uniformity and no line defect. Partial transformation of the module parts should be ignored.

Fail: No display image, obvious non-uniformity, or line defects.

Note2: Evaluation should be tested after storage at room temperature for two hour.

Note 3: The MTBF calculation is based on the assumption that the failure rate distribution meets the Exponential Model.

## **E. Safety**

### **1. Sharp Edge Requirements**

There will be no sharp edges or corners on the display assembly that could cause injury.

### **2. Materials**

#### **a. Toxicity**

There will be no carcinogenic materials used anywhere in the display module. If toxic materials are used, they will be reviewed and approved by the responsible InnoLux Toxicologist.

#### **b. Flammability**

All components including electrical components that do not meet the flammability grade UL94-V1 in the module will complete the flammability rating exception approval process. The printed circuit board will be made from material rated 94-V1 or better. The actual UL flammability rating will be printed on the printed circuit board.

#### **c. Capacitors**

If any polarized capacitors are used in the display assembly, provisions will be made to keep them from being inserted backwards.

## **F. Display quality**

The display quality of the color TFT-LCD module should be in compliance with the InnoLux's Incoming inspection standard.

## **G. Handling precaution**

The Handling of the TFT-LCD should be in compliance with the InnoLux's handling principle standard.

**H. Label**

1. Module Label

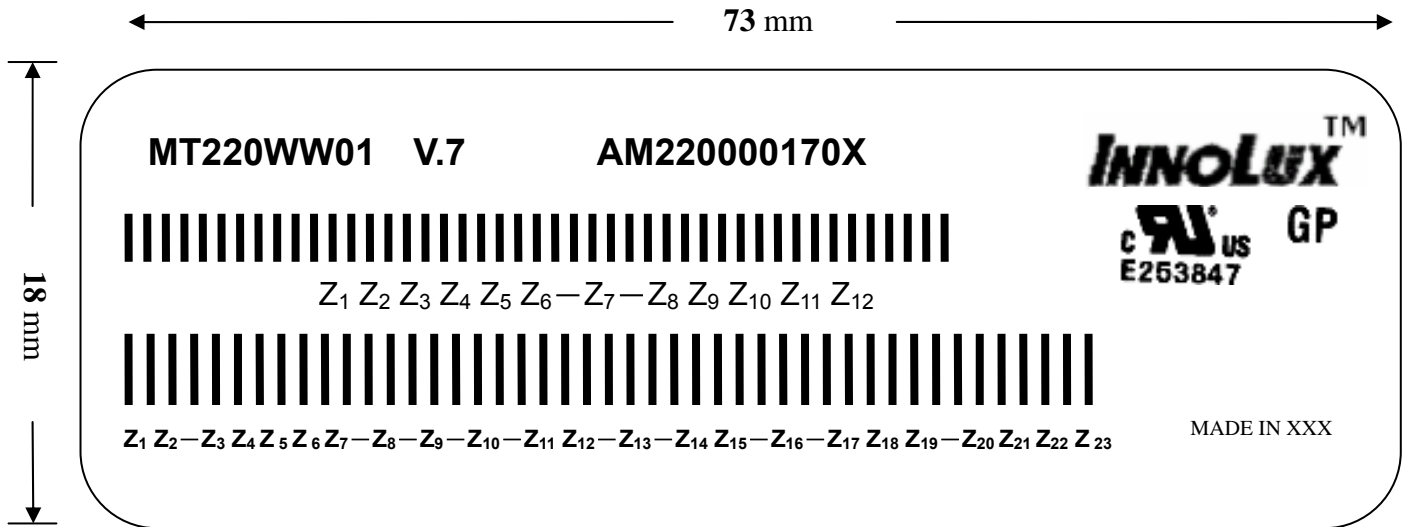

(a) Model Number: MT220WW01

(b) Version: V.7

(c) Serial ID I: Z<sub>1</sub> Z<sub>2</sub> Z<sub>3</sub> Z<sub>4</sub> Z<sub>5</sub> Z<sub>6</sub> Z<sub>7</sub> Z<sub>8</sub> Z<sub>9</sub> Z<sub>10</sub> Z<sub>11</sub> Z<sub>12</sub>

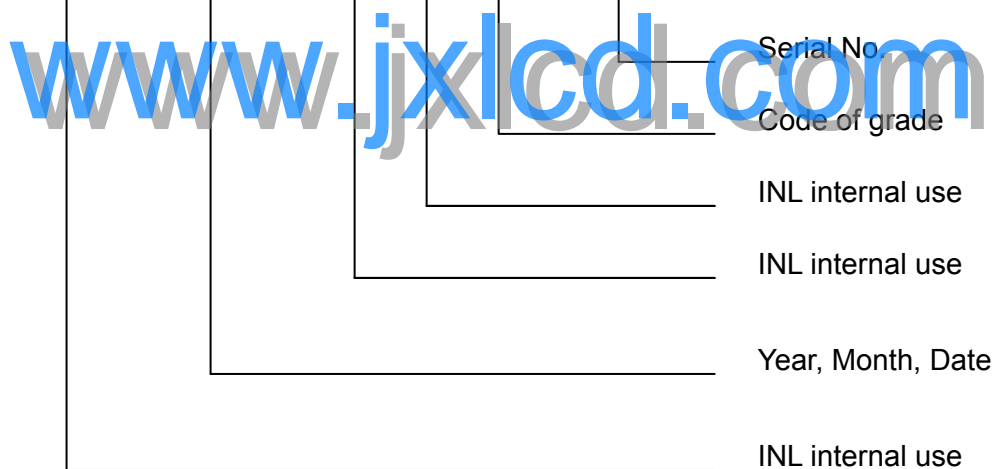

Serial ID includes the information as below:

1. Manufactured Date: Year: 0~9, for 2000~2009
2. Month: 1~9 & A~C for Jan.~Dec.
3. Date: 1~9 & A~Z (exclude I, O, Q, U) for 1th~31th
4. Code of grade: 1, 2, 3, 5, E
5. Serial No.: Module manufacture sequence number.

(d) Serial ID II (INL internal use)

2. Carton Label

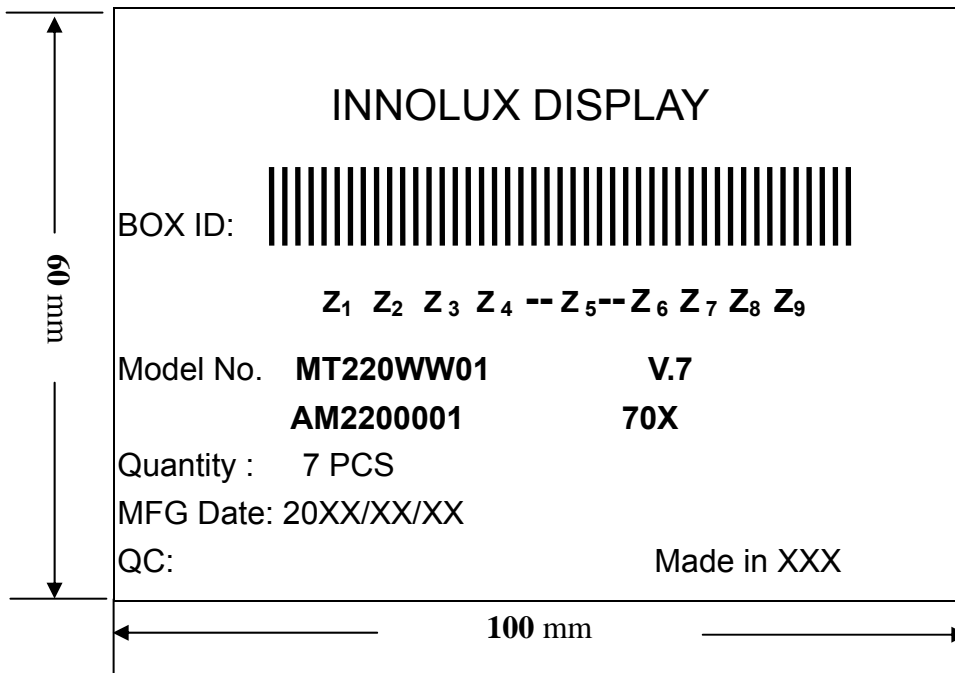

- (a) Model Number: MT220WW01
- (b) Version: V.7
- (c) Packing quantity: 7 pcs
- (d) Serial ID: Z<sub>1</sub> Z<sub>2</sub> Z<sub>3</sub> Z<sub>4</sub> Z<sub>5</sub> Z<sub>6</sub> Z<sub>7</sub> Z<sub>8</sub> Z<sub>9</sub>

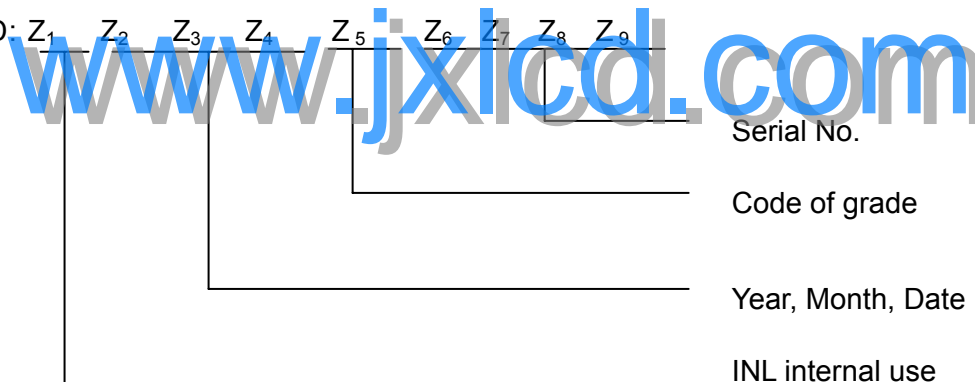

Serial ID includes the information as below :

- (a) Manufactured Date: Year: 0~9, for 2000~2009  
Month: 1~9 & A~C for Jan.~Dec.  
Date: 1~9 & A~Z (exclude I, O, Q, U) for 1th~31th
- (b) Code of grade: 1, 2, 3, 5, E
- (c) Serial No.: Module packing sequence number.

# I. Mechanical drawing

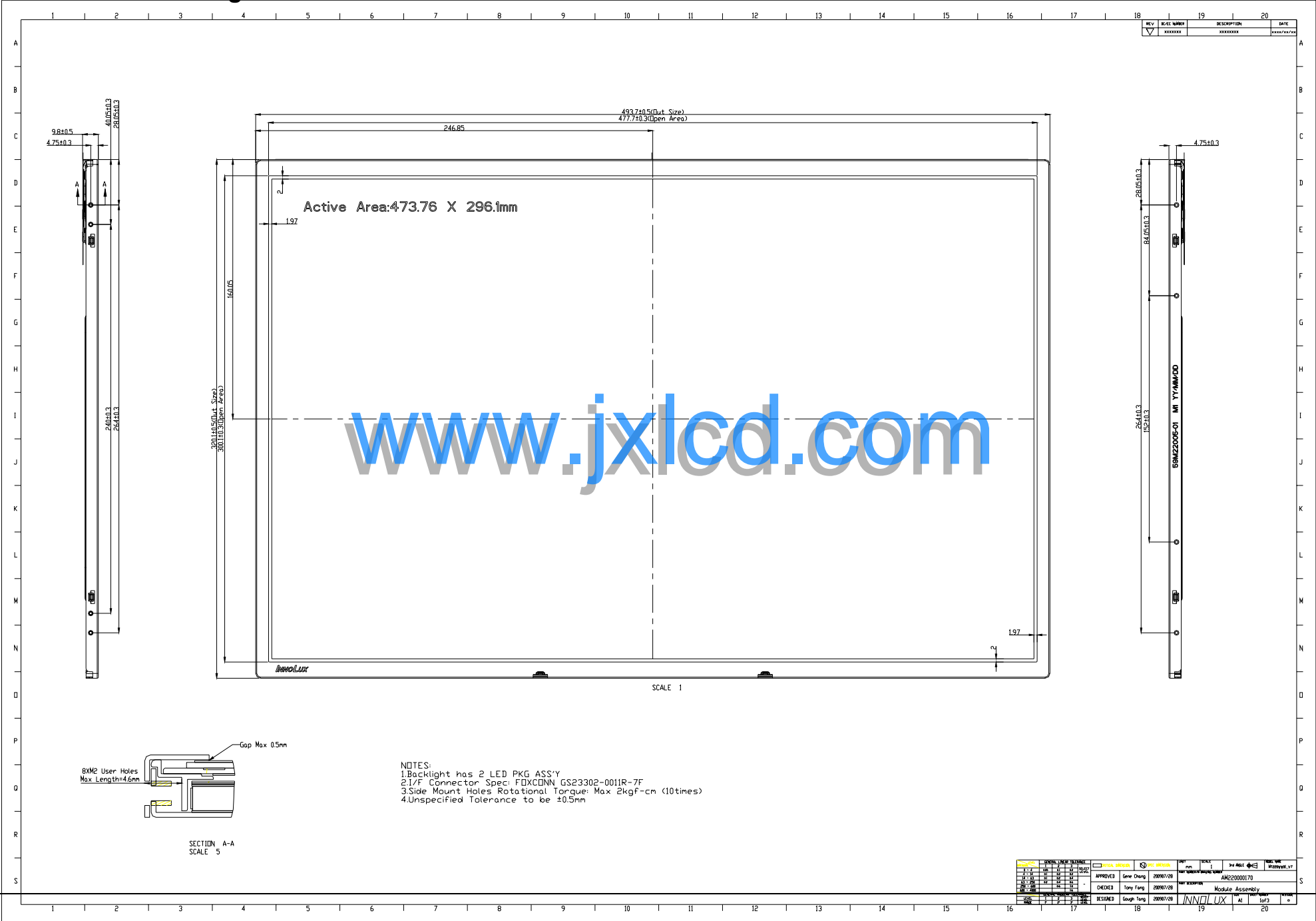

REV	REV. NUMBER	DESCRIPTION	DATE
1	XXXXXX	XXXXXXXX	XXXX/XX/XX

NO.	REV.	DATE	BY	CHK.	APP.	DESCRIPTION
1						
2						
3						
4						
5						
6						
7						
8						
9						
10						
11						
12						
13						
14						
15						
16						
17						
18						
19						
20						

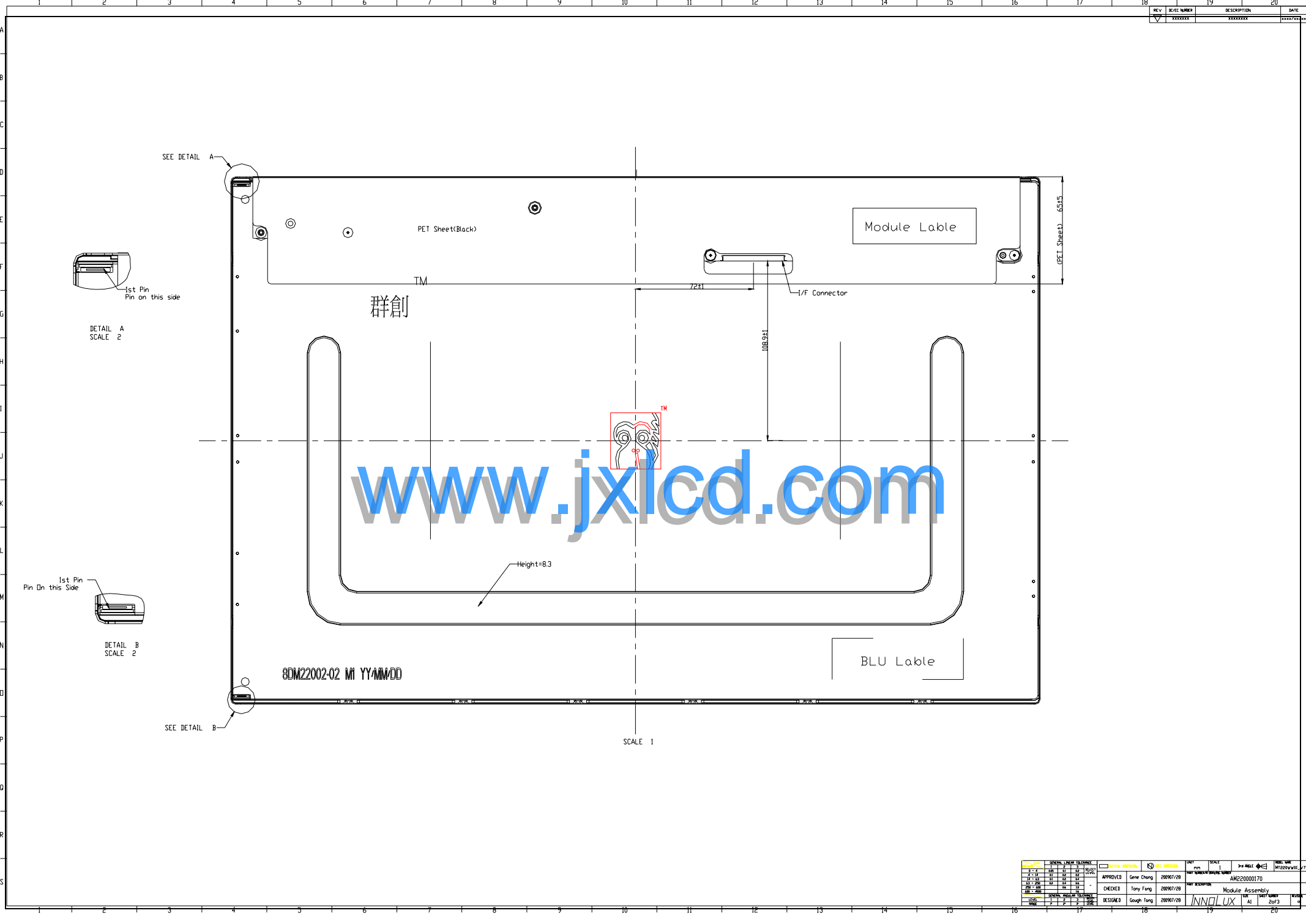

[www.jxlcd.com](http://www.jxlcd.com)

APPROVED	Gene Chung	2009/7/28	AM220000170
CHECKED	Tony Tang	2009/7/28	Module Assembly
DESIGNED	Gough Tang	2009/7/28	INNO LUX