

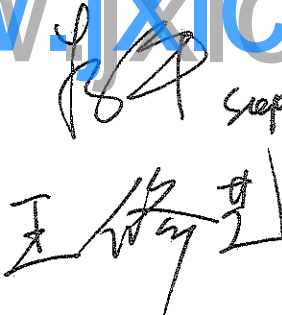

INNOLUX DISPLAY CORPORATION

MT230DW01 V.2 LCD MODULE SPECIFICATION

() Preliminary Specification

(●) Final Specification

Approved by	Checked by	Prepared by
 10/9/09	 9/4/09	 09.9.4

Innolux Display Corporation,

No.160 Kesuye Rd., Chu-Nan Site, Hsinchu Science Park,

Chu-Nan 350, Miao-Li County, Taiwan

Tel: 886-37-586000

Fax: 886-37-586060

Document Number: MT230DW01 V.2-DR4-26

Contents:	
A. General Specification	
B. Electrical Specifications	
1. Pin Assignment	
2. Absolute Maximum Ratings	
3. Electrical Characteristics	
a. Typical Operating Conditions	
b. Display Color vs. Input Data Signals	
c. Input Signal Timing	
d. Display Position	
e. Backlight Unit	
C. Optical Specifications	
D. Reliability Test Items	
E. Safety	
F. Display Quality	
G. Handling Precaution	
H. Label	
I. Mechanical Drawings	
Appendix	



A. General Specification

NO.	Item	Specification	Remark
1	Display resolution (pixel)	1,920(H) X 1,080(V), Full HD	
2	Active area (mm)	509.184(H) x 286.416(V)	
3	Screen size (inch)	23 inches diagonal	
4	Pixel pitch (mm)	0.2652(H) X 0.2652(V)	
5	Color configuration	R, G, B vertical stripe	
6	Overall dimension (mm)	533.2(H) x 312.0 (V) x9.8(D) (Typ.)	
7	Weight (g)	1900 (Max.)	
8	Surface treatment	Anti-Glare, Haze=25%, Hard coating (3H)	Note 1
9	Input color signal	8 bit LVDS	
10	Display colors	16.7M (6 bit with Hi-FRC)	
11	Color Saturation	70% NTSC	
12	Optimum viewing direction	6 o'clock	
13	Backlight	Side-light bar (White LED)	
14	RoHS & Halogen Free	RoHS & Halogen Free compliance	
15	TCO 5.0	TCO 5.0 Compliance	Note 2

Note 1: Glare Option available.

Note 2 : Only Anti-Glare can meet TCO 5.0.

B. Electrical Specifications

1. Pin Assignment

1.1. LVDS Connector

Foxconn GS23302-0011R-7F or mechanical interface equivalent connector.

No	Symbol	Description
1	RxO0-	LVDS Differential data input Channel 0(-)
2	RxO0+	LVDS Differential data input Channel 0(+)
3	RxO1-	LVDS Differential data input Channel 1(-)
4	RxO1+	LVDS Differential data input Channel 1(+)
5	RxO2-	LVDS Differential data input Channel 2(-)
6	RxO2+	LVDS Differential data input Channel 2(+)
7	GND	Ground
8	RxOC-	LVDS Differential Clock input (-)
9	RxOC+	LVDS Differential Clock input (+)
10	RxO3-	LVDS Differential data input Channel 3(-)
11	RxO3+	LVDS Differential data input Channel 3(+)
12	RxE0-	LVDS Differential data input Channel 0(-)
13	RxE0+	LVDS Differential data input Channel 0(+)
14	GND	Ground
15	RxE1-	LVDS Differential data input Channel 1(-)
16	RxE1+	LVDS Differential data input Channel 1(+)
17	GND	Ground
18	RxE2-	LVDS Differential data input Channel 2(-)
19	RxE2+	LVDS Differential data input Channel 2(+)
20	RxEC-	LVDS Differential Clock input (-)
21	RxEC+	LVDS Differential Clock input (+)
22	RxE3-	LVDS Differential data input Channel 3(-)
23	RxE3+	LVDS Differential data input Channel 3(+)
24	GND	Ground
25	NC	No Connection
26	NC	No Connection
27	NC	No Connection
28	VCC	Power supply (+5.0V)
29	VCC	Power supply (+5.0V)
30	VCC	Power supply (+5.0V)

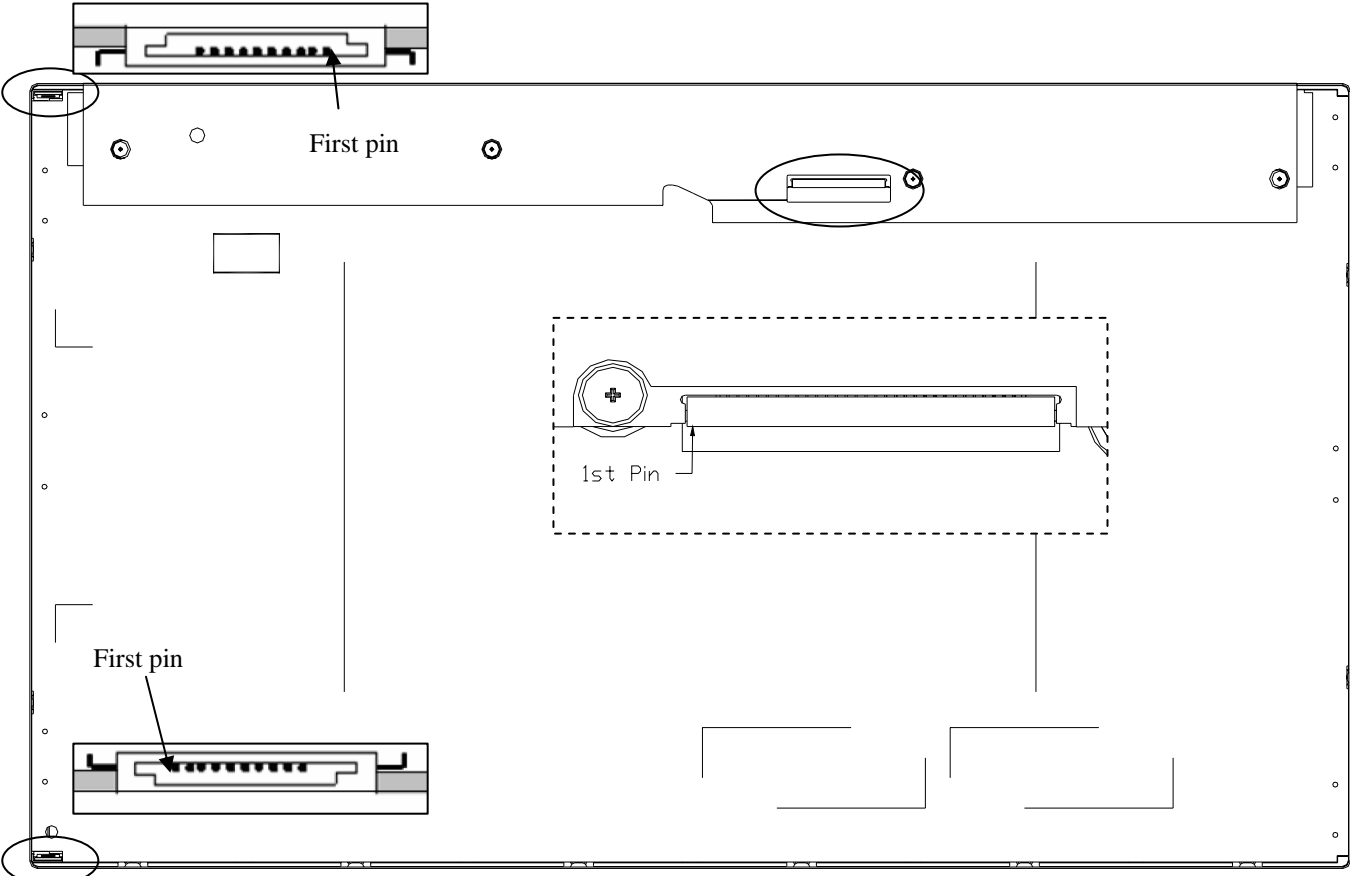

www.jxlcd.com **Rear View of LCM**

1.2 Recommend Connector for Backlight Unit

This connector is mounted on the monitor system board for LED light-bar FFC mating.

Connector Name/Designation	Match Connector
Manufacturer	Entery INDUSTRIAL CO.,LTD
Mating type part number	7080-Q10N-00R

1.3 LED Light Bar Connector

Upper Connector Pin Assignment:

Pin No	Symbol	Description
1	IRLED1	LED current sense for string 1
2	IRLED1	LED current sense for string 1
3	IRLED2	LED current sense for string 2
4	VLED	LED power supply
5	VLED	LED power supply
6	VLED	LED power supply
7	VLED	LED power supply
8	IRLED2	LED current sense for string 2
9	IRLED3	LED current sense for string 3
10	IRLED3	LED current sense for string 3

Lower Connector Pin Assignment:

Pin No	Symbol	Description
1	IRLED1	LED current sense for string 1
2	IRLED1	LED current sense for string 1
3	IRLED2	LED current sense for string 2
4	VLED	LED power supply
5	VLED	LED power supply
6	VLED	LED power supply
7	VLED	LED power supply
8	IRLED2	LED current sense for string 2
9	IRLED3	LED current sense for string 3
10	IRLED3	LED current sense for string 3

www.jxlcd.com

2. Absolute Maximum Ratings

Parameter	Symbol	Values			Unit	Remark
		Min.	Typ.	Max.		
Power voltage	V_{CC}	-0.3	-	6.0	V	At 25°C
Input signal voltage	V_{LH}	-0.3	-	4.3	V	At 25°C
Operating temperature	T_{op}	0	-	50	°C	Note 1
Storage temperature	T_{ST}	-20	-	60	°C	Note 2
Operating Humidity	H_{op}	20	-	90	%RH	Note 1
Storage Humidity	HST	10	-	90	%RH	Note 1

Note 1: The relative humidity must not exceed 90% non-condensing at temperatures of 40°C or less.

At temperatures greater than 40°C, the wet bulb temperature must not exceed 39°C.

Note 2: The unit should not be exposed to corrosive chemicals.

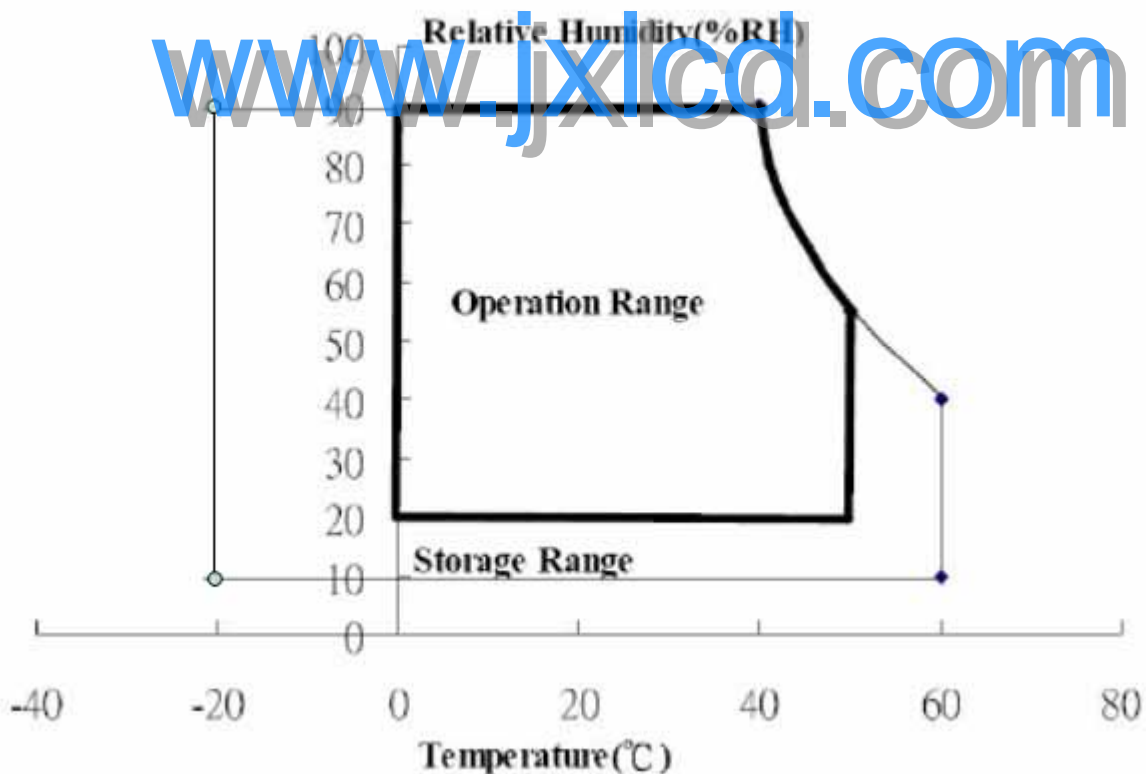

3. Electrical Characteristics

a. Typical operating conditions

Item		Symbol	Min.	Typ.	Max.	Unit	Remark
Input Voltage		V_{CC}	4.5	5	5.5	V	
Permissive Power Input Ripple		V_{RF}	-	-	400	mVp-p	
Input Current	Black	I_{CC}	-	1000	-	mA	Note 1
	White	I_{CC}	-	800	-		Note 2
	Mosaic	I_{CC}	-	950	-		Note 3
Rush Current		I_{Rush}	-	1.6	3	A	Note 4
Logic Input	Common Mode Voltage	VCM	-	1.2	-	V	
Voltage LVDS: IN+, IN-	Differential Input Voltage	VID	100	-	600	mV	
	Threshold Voltage (High)	VTH	-	-	100	mV	Note 5, 6
	Threshold Voltage (Low)	VTL	-100	-	-	mV	Note 5, 6

Note 1: The specified current is under the $V_{CC} = 5V$, $25^{\circ}C$, $f_v = 60Hz$ (frame frequency) condition whereas black pattern is displayed.

Note 2: The specified current is under the $V_{CC} = 5V$, $25^{\circ}C$, $f_v = 60Hz$ (frame frequency) condition whereas white pattern is displayed.

Note 3: The specified current is under the $V_{CC} = 5V$, $25^{\circ}C$, $f_v = 60Hz$ (frame frequency) condition whereas mosaic pattern (black & white [8*6]) is displayed.

White: 255 Gray

Black: 0 Gray

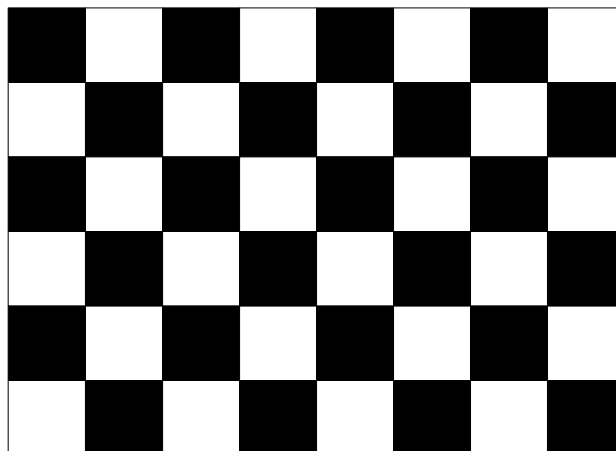

Note 4: Test condition:

- (1). $V_{DD} = 5\text{ V}$, V_{DD} rising time = $470\ \mu\text{s} \pm 10\%$
- (2). Pattern: Mosaic pattern

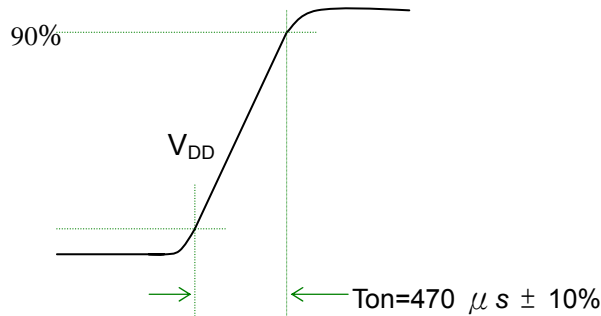

(3) Test circuit

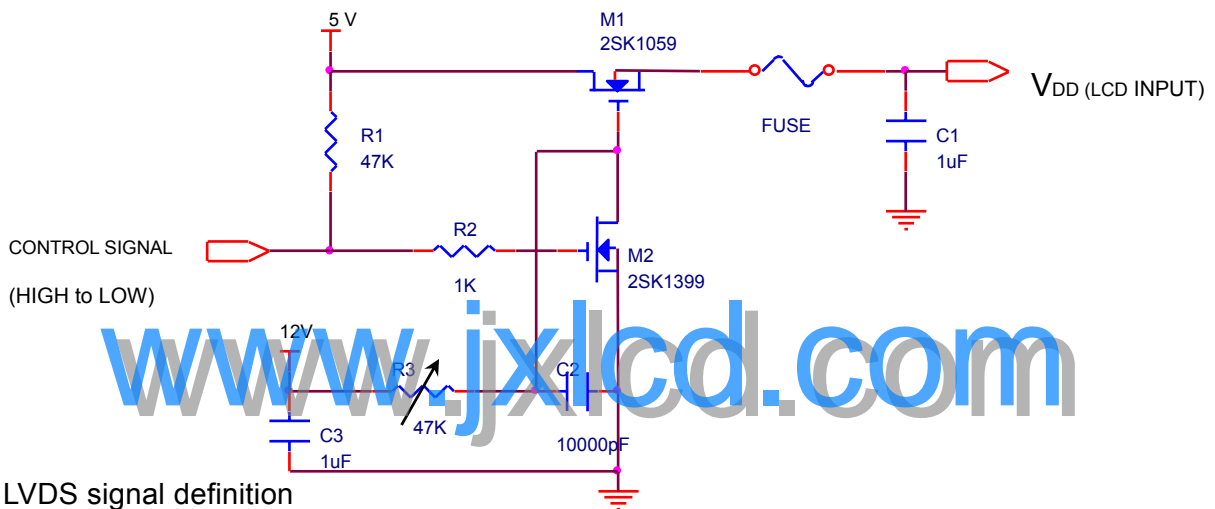

Note 5: LVDS signal definition

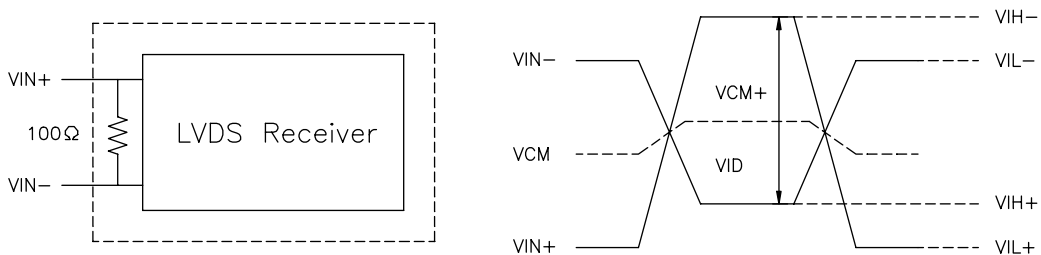

- VIN_+ = Positive differential DATA & CLK Input
- VIN_- = Negative differential DATA & CLK Input
- $VID = VIN_+ - VIN_-$,
- $\Delta VCM = |VCM_+ - VCM_-|$,
- $\Delta VID = |VID_+ - VID_-|$,
- $VID_+ = |VIH_- - VIH_-|$,
- $VID_- = |VIL_+ - VIL_-|$,
- $VCM = (VIN_+ + VIN_-)/2$,
- $VCM_+ = (VIH_+ + VIH_-)/2$,
- $VCM_- = (VIL_+ + VIL_-)/2$,

Note 6: Power on sequence for LCD V_{DD}

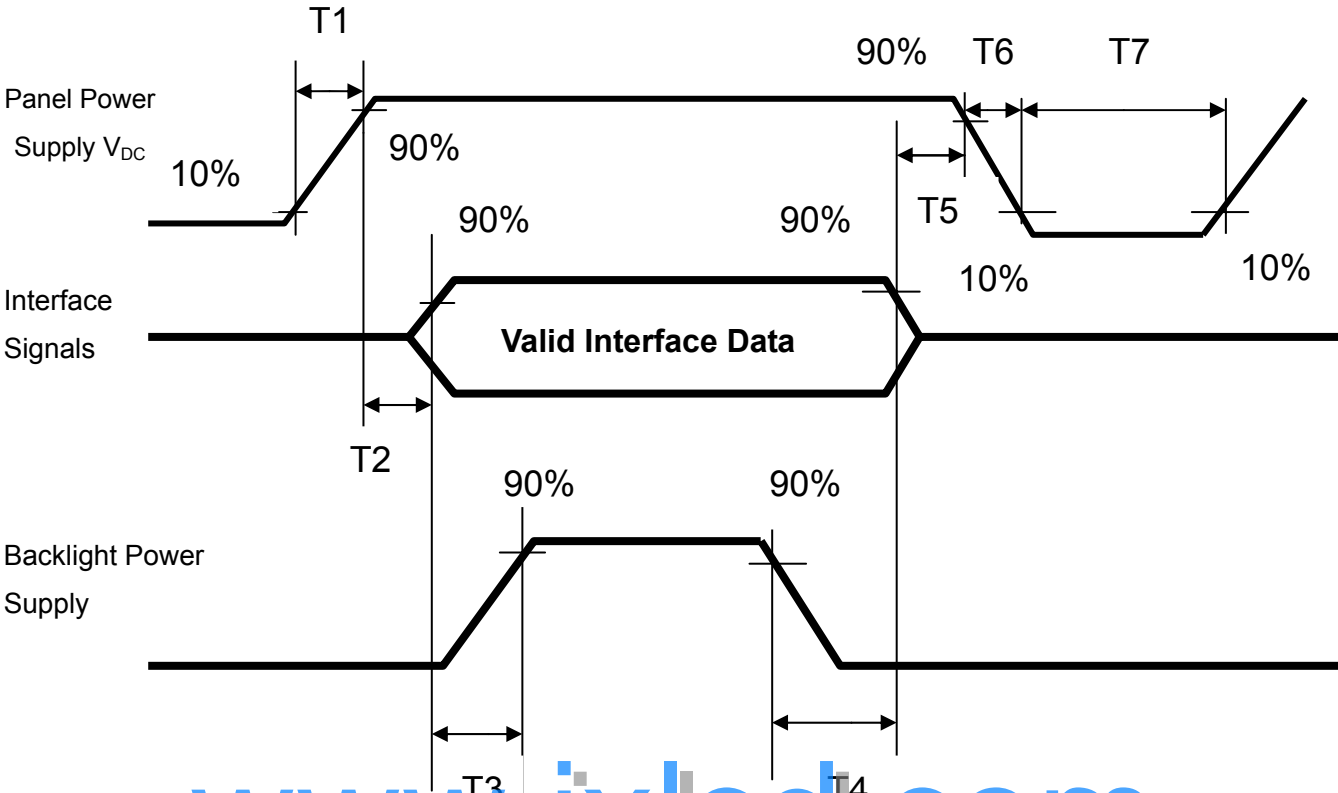

www.jxlcd.com

Parameter	Value			Unit
	Min	Typ.	Max	
T1	0.1	-	10	ms
T2	0	30	50	ms
T3	200	250	-	ms
T4	100	250	-	ms
T5	0	20	50	ms
T6	0.1	-	10	ms
T7	1000	-	-	ms

c. Input Signal Timing
Support Input Timing Table

	Item	Description	Min.	Typ.	Max.	Unit
Clock	Dclk	period	11.43	13.89	16.7	nS
		frequency	60	72	87.5	MHz
Vertical	T_{V_TOTAL}	V total line number	1090	1100	1160	T_{H_TOTAL}
	T_{V_DATA}	Data duration	1080	1080	1080	T_{H_TOTAL}
	T_{VB}	V-blank	10	20	80	T_{H_TOTAL}
	f_V	frequency	50	60	75	Hz
Horizontal	T_{H_TOTAL}	H total pixel number	1000	1088	1120	DClk
	T_{H_DATA}	Data duration	960	960	960	DClk
	T_{HB}	H-blank	40	128	160	DClk

Note: Because this module is operated by DE mode only, Hsync and Vsync input signals should be set to low Logic level or ground. Otherwise, this module would operate abnormally.

INPUT SIGNAL TIMING DIAGRAM

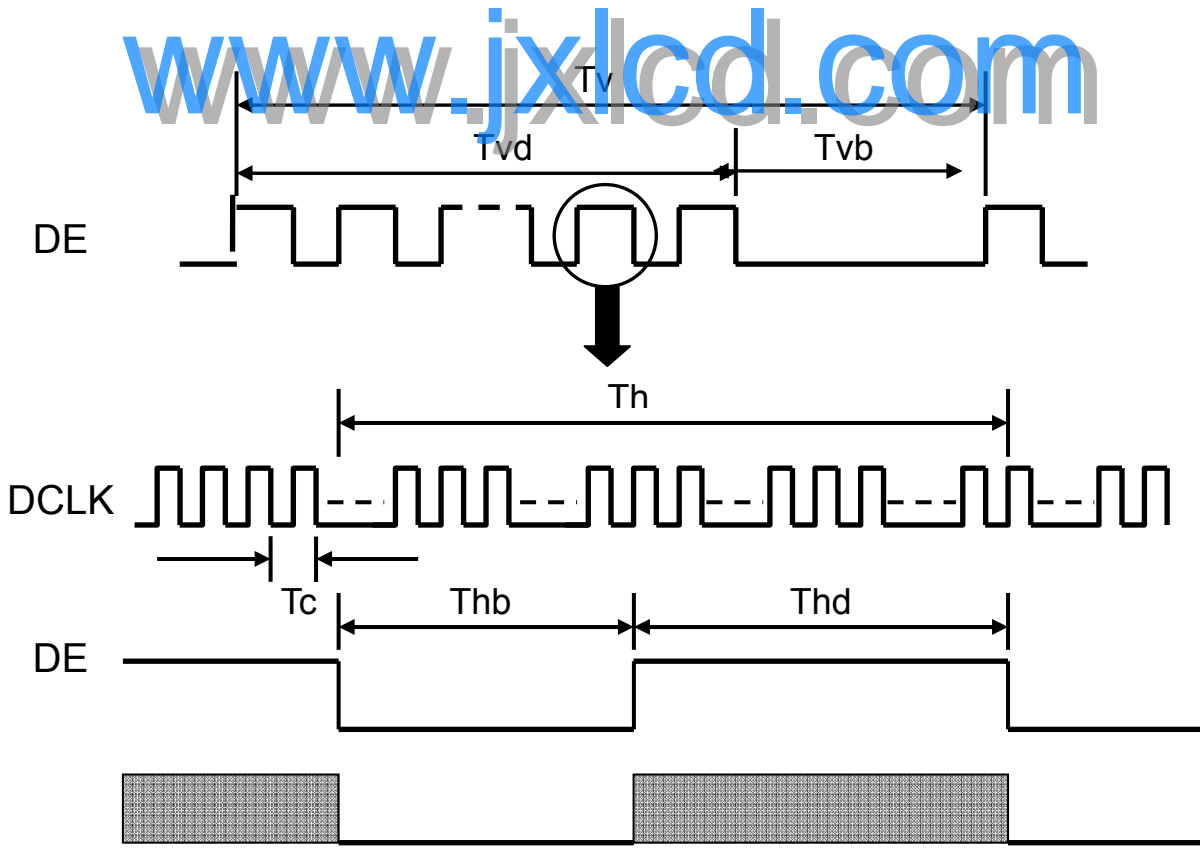

d. Display Position

D(1,1)	D(2,1)	D(960,1)	D(1919,1)	D(1920,1)
D(1,2)	D(2,2)	D(960,2)	D(1919,2)	D(1920,2)
⋮	⋮	⋮	⋮	⋮
D(1,540)	D(2,540)	D(960,540)	D(1919,540)	D(1920,540)
⋮	⋮	⋮	⋮	⋮
D(1,1079)	D(2,1079)	D(960,1079)	D(1919,1079)	D(1920,1079)
D(1,1080)	D(2,1080)	D(960,1080)	D(1919,1080)	D(1920,1080)

e. Backlight Unit

Parameter	Symbol	Value			Unit	Note
		Min.	Typ.	Max.		
Light Bar Input Voltage	VLED		39.6	40.8	VDC	(Duty 100%)
Light Bar Input Current	ILED			360	mADC	Note 1, 2, 3
Power Consumption	PLED			14.67	W	Note 4
LED Life Time	LBL	---	30000	---	Hrs	Note 5

Note 1: There are two Light Bars, and the specified current is input LED chip 100% duty current.

Note 2: The sensing current of each string is 60mA.

Note 3: Each light bar have three current sensing strings, so that each light bar input current is 180mA.

Note 4: $PLED = ILED \times VLED$.

Note 5: The life time is determined as the time at which luminance of the LED becomes 50% of the initial brightness or not normal lighting at the current $I_{LED}=360mA$ on condition of continuous operating at $25\pm 2^{\circ}C$.

C. Optical Specifications

Item	Symbol	Condition	Specification			Unit	Remark
			Min.	Typ.	Max.		
Response time	Tr	$\theta = 0^\circ$	-	1.5	3	ms	Note 2
	Tf		-	3.5	7		
	Tr+Tf		-	5	10		
Contrast ratio	CR	$\theta = 0^\circ$	700	1000	-		Note 1,3
Viewing angle	Top	CR 10	70	80	-	deg.	Note 1,3,5
	Bottom	CR 10	70	80	-		
	Left	CR 10	75	85	-		
	Right	CR 10	75	85	-		
Brightness (Center)	YL		250	300	-	nit	Note 1,4
Color chromaticity(CIE)	Wx	$\theta = 0^\circ$	-0.03	0.313	+0.03		Note 1
	Wy			0.329			
	Rx			0.639			
	Ry			0.345			
	Gx			0.324			
	Gy			0.621			
	Bx			0.150			
	By			0.059			
White uniformity (9 points)	δW		0.7	0.75	-		Note 1,6
Cross talk	Ct		-	-	2%		Note 7

Note: Ambient temperature = 25°C.

To be measured in dark room after backlight warm up 10 minutes.

Note 1: To be measured with a viewing cone of 2° by Topcon luminance meter BM-5A.

Note 2: Definition of response time:

The output signals of BM-7 are measured when the input signals are changed from "Black" to "White" (falling time) and from "White" to "Black" (rising time), respectively. The response time interval is between the 10% and 90% of amplitudes. Refer to figure as below.

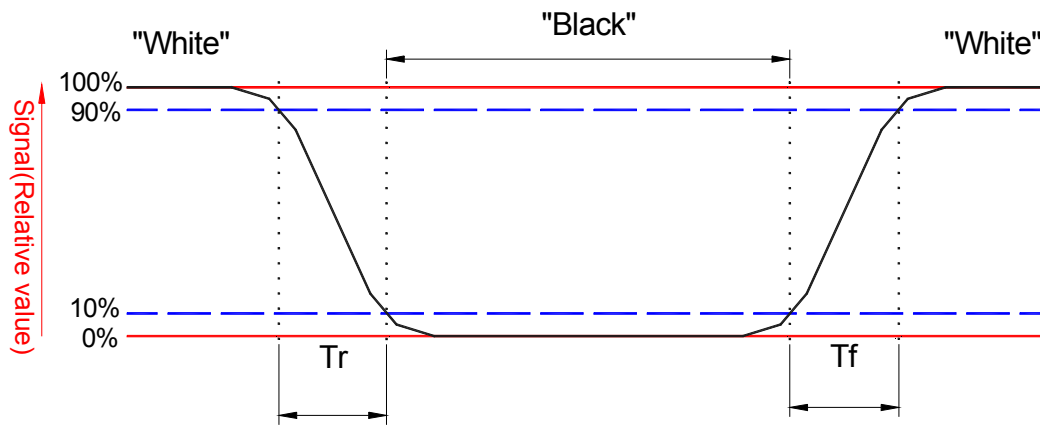

Note 3: Definition of contrast ratio:

Contrast ratio is calculated by the following formula.

$$\text{Contrast ratio (CR)} = \frac{\text{Brightness on the "white" state}}{\text{Brightness on the "black" state}}$$

Note 4: Driving conditions for LED Light Bar: $I_{LED}=360\text{mA}$.

Note 5: Definition of viewing angle

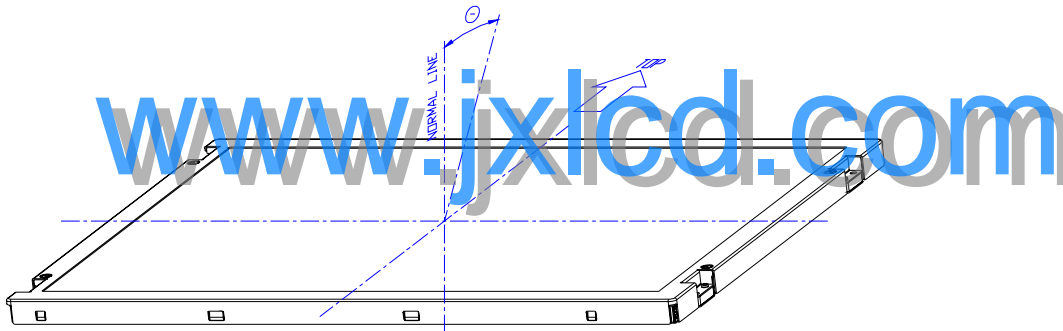

Note 6: Definition white uniformity:

Luminance are measured at the following nine points (P1~P9).

$$\delta_w = \frac{\text{Minimum Brightness of nine points (P1~P9)}}{\text{Maximum Brightness of nine points (P1~P9)}}$$

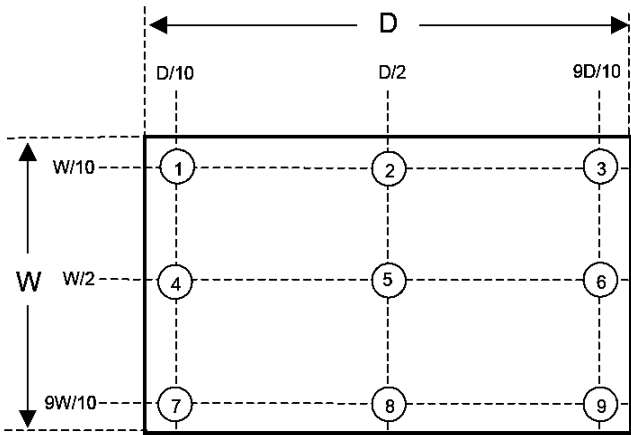

Note 7:

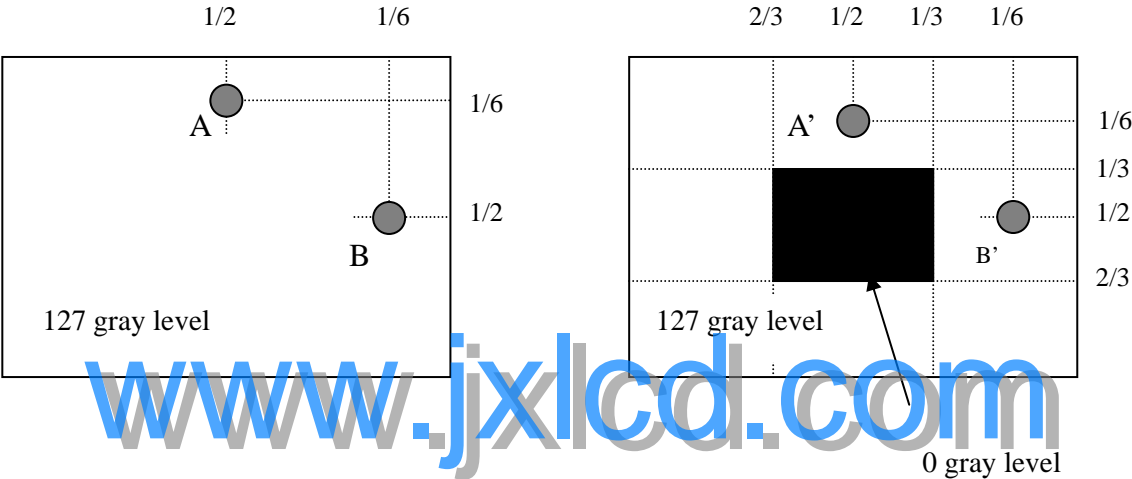

$|L_A - L_{A'}| / L_A \times 100\% = 2\% \text{ max.}$, L_A and $L_{A'}$ are brightness at location A and A'
 $|L_B - L_{B'}| / L_B \times 100\% = 2\% \text{ max.}$, L_B and $L_{B'}$ are brightness at location B and B'

Note 10: Optical characteristic measurement setup.

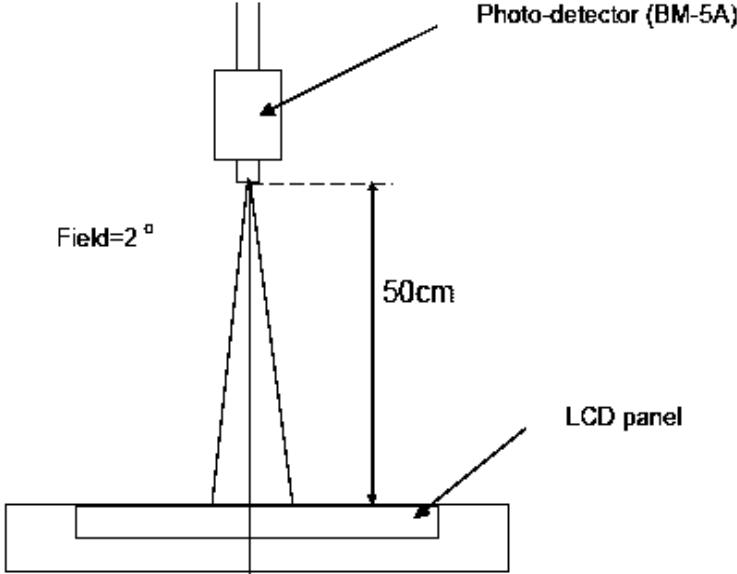

D. Reliability Test Items

Test Item	Test Condition	Judgment	Remark
High temperature storage	60°C, 240Hrs	Note 1	Note 2
Low temperature storage	-20°C, 240Hrs	Note 1	Note 2
High temperature & high humidity operation	40°C, 90%RH, 240Hrs (No condensation)	Note 1	Note 2
High temperature operation	50°C, 240Hrs	Note 1	Note 2
Low temperature operation	0°C, 240Hrs	Note 1	Note 2
Thermal Shock (non-operation)	-20°C~60°C -20°C /1Hr, 60°C /1Hr, 100cycles	Note 1	Note 2
Electrostatic discharge (ESD) (non-operation)	Contact: +/-8kV, 150pF(330ohms), 10 times/1 point, 1 time/1 sec, total 16 points Air discharge: +/-15kV, 150pF(330ohms), 10 times/1 point, 1 time/1 sec, total 9 points	Note 1	Note 2
Vibration (non-operation)	Vibration level : 1.5G Bandwidth : 10-300Hz Waveform : sine wave, sweep rate : 10min 30 min for each direction X, Y, Z (1.5 Hrs in total)	Note 1	Note 2
Mechanical Shock (non-operation)	Shock level : 50G, 11ms Waveform : Half sine wave Direction : ±X, ±Y, ±Z One time each direction	Note 1	Note 2
MTBF Demonstration	30,000 hours with confidence level 90%	Note 1	Note 3

Note 1: Pass: Normal display image with no obvious non-uniformity and no line defect.

Partial transformation of the module parts should be ignored.

Fail: No display image, obvious non-uniformity, or line defects.

Note 2: Evaluation should be tested after storage at room temperature for two hours.

Note 3: The MTBF calculation is based on the assumption that the failure rate distribution meets the Exponential Model.

E. Safety

(1). Sharp Edge Requirements

There will be no sharp edges or corners on the display assembly that could cause injury.

(2). Materials

a. Toxicity

There will be no carcinogenic materials used anywhere in the display module. If toxic materials are used, they will be reviewed and approved by the responsible InnoLux Toxicologist.

b. Flammability

All components including electrical components that do not meet the flammability grade UL94-V1 in the module will complete the flammability rating exception approval process. The printed circuit board will be made from material rated 94-V1 or better. The actual UL flammability rating will be printed on the printed circuit board.

c. Capacitors

If any polarized capacitors are used in the display assembly, provisions will be made to keep them from being inserted backwards.

F. Display Quality

The display quality of the color TFT-LCD module should be in compliance with the Innolux's Incoming inspection standard.

G. Handling Precaution

The Handling of the TFT-LCD should be in compliance with the Innolux's handling principle standard.

www.jxlcd.com

H. Label

(1). Module Label

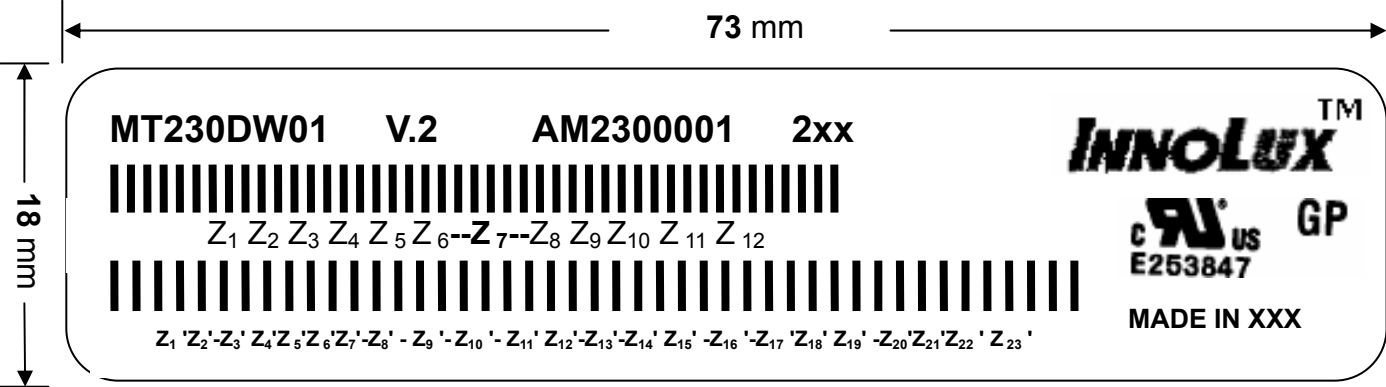

(a). Model Number: MT230DW01

(b). Version: V.2

(c). Serial ID I: Z₁ Z₂ Z₃ Z₄ Z₅ Z₆ Z₇ Z₈ Z₉ Z₁₀ Z₁₁ Z₁₂



Serial ID includes the information as below:

1. Manufactured Date: Year: 0~9, for 2000~2009
2. Month: 1~9 & A~C for Jan. ~ Dec.
3. Date: 1~9 & A~Z (exclude I, O, Q, U) for 1st~31th
4. Code of grade: 1, 2, 3, 5, E
5. Serial No: Module manufacture sequence no

(d). Serial ID II (INL internal use)

(2) Carton Label

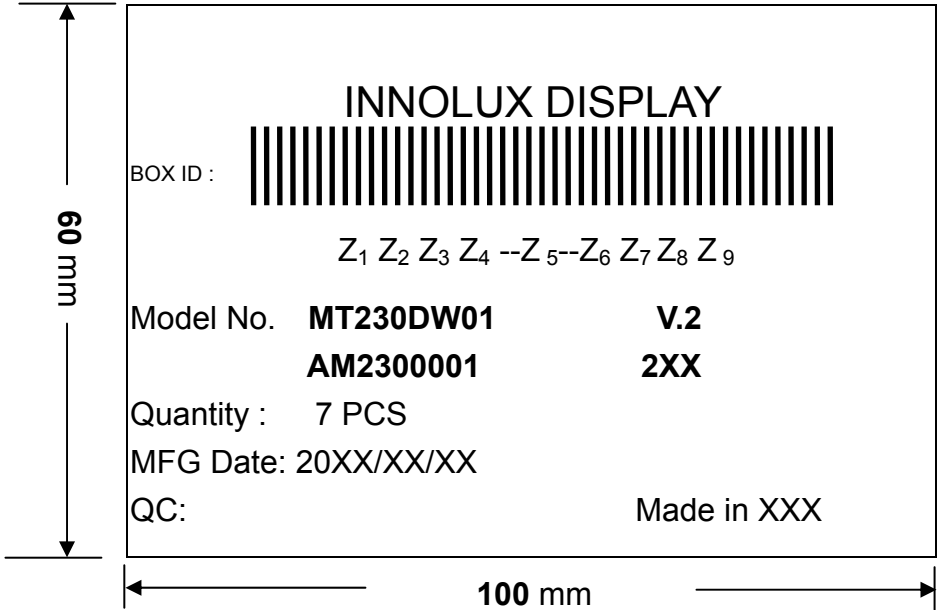

(a). Model Number: MT230DW01

(b). Version: V.2

(c). Packing quantity: 7 pcs

(d). Serial ID: Z₁ Z₂ Z₃ Z₄ Z₅ Z₆ Z₇ Z₈ Z₉

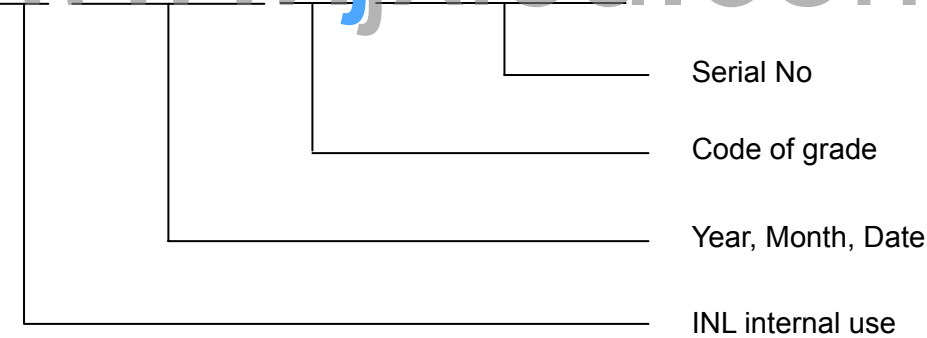
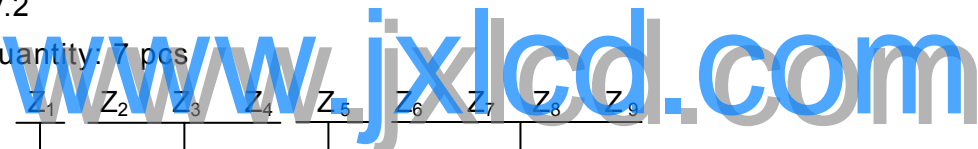

Serial ID includes the information as below:

- (a). Manufactured Date: Year: 0~9, for 2000 ~2009
 Month: 1~9 & A~C for Jan. ~ Dec.
 Date: 1~9 & A~Z (exclude I, O, Q, U) for 1st~31th
- (b). Code of grade: 1, 2, 3, 5, E
- (c). Serial No: Module packing sequence no.

REV	REV#	DESCRIPTION	DATE
1	000000	000000	000000



SCALE 1

- NOTES:
1. TORQUE OF (8x)M2 USER HOLE BOSS SHOULD BE WITHIN 2 kg-cm AND RESCREW 10 TIMES.
 2. FFC CONNECTOR SPEC: Entery,7080K-F-ION-OOR
 3. I/F CONNECTOR SPEC:Foxconn GS23302-0011R-7F OR MECHANICAL INTERFACE EQUIVALENT CONNECTOR

REV	REV#	DESCRIPTION	DATE
1	000000	000000	000000

APPROVED	Jack Chen	2009/05/26	2009/05/26	AM230000120X	MT230DWO1_V2
CHECKED	Alex Pan	2009/05/26	2009/05/26	Module Assy	
DESIGNED	Janney Liu	2009/05/26	2009/05/26		

INNOVOLUX

REV	REV NUMBER	DESCRIPTION	DATE
▽	XXXXXX	XXXXXXXX	XXXX/XX/XX

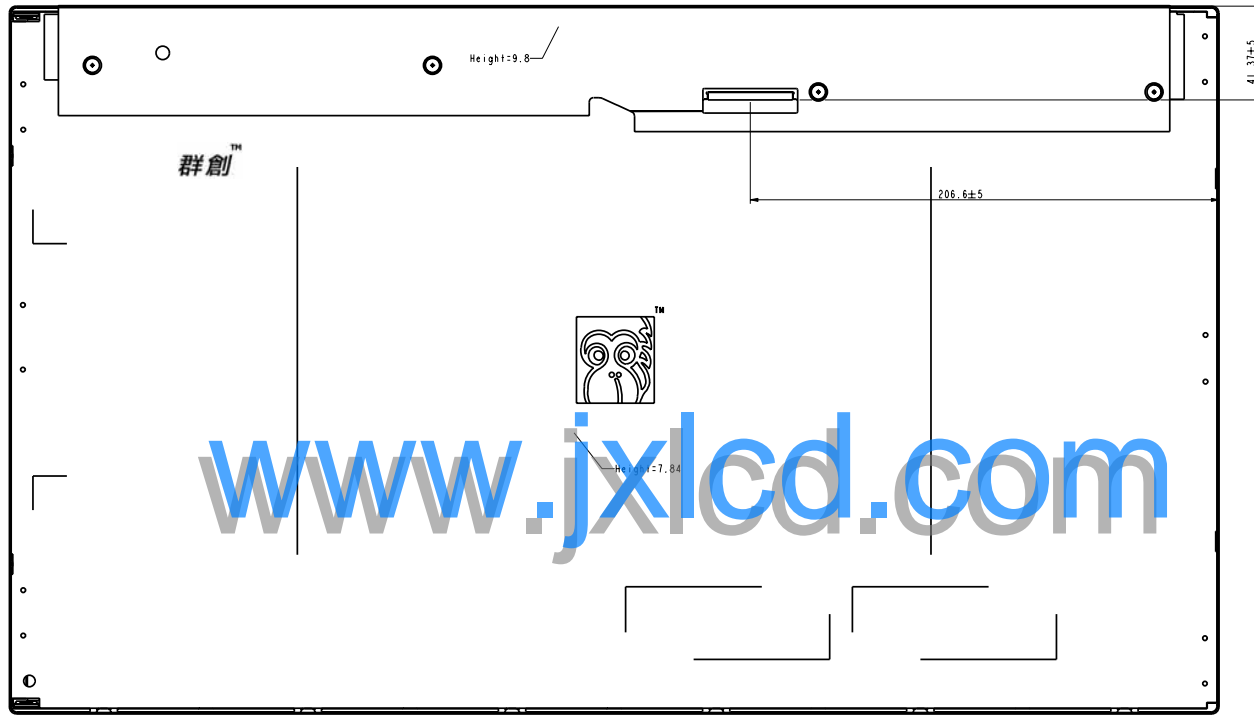

SCALE 0.9

NOTES:

1. TORQUE OF (8x)M2 USER HOLE BOSS SHOULD BE WITHIN 2 kg-cm AND RESCREW 10 TIMES.
2. FFC CONNECTOR SPEC: Entery, 7080K-F-10N-OOR
3. I/F CONNECTOR SPEC: Foxconn GS23302-0011R-7F OR MECHANICAL INTERFACE EQUIVALENT CONNECTOR

REV	REV NUMBER	DESCRIPTION	DATE
▽	XXXXXX	XXXXXXXX	XXXX/XX/XX

NO.	REVISION	DATE	BY	CHKD	APP'D
1	INITIAL DESIGN	2009/05/26	Jack Chen		
2	CHECKED	2009/05/26	Alex Pan		
3	DESIGNED	2009/05/26	Janey Lin		

ITEM NO.	DESCRIPTION	QTY	UNIT
1	MT2300W01_V2	1	PCBA
2	AM230000120X	1	Module Assy