



INNOLUX DISPLAY CORPORATION

MT230DW01 V.3 LCD MODULE SPECIFICATION

() Preliminary Specification

(●) Final Specification

Customer	Checked and Approved by

<i>Approved by</i>	<i>Checked by</i>	<i>Prepared by</i>

Innolux Display Corporation,

No.160 Kesyue Rd., Chu-Nan Site, Hsinchu Science Park,

Chu-Nan 350, Miao-Li County, Taiwan

Tel: 886-37-586000

Fax: 886-37-586060

Document Number: MT230DW01 V.3 DR4-26



SPEC NO. MT230DW01 V.3

PAGE 3/23

Contents:	
A. General Specification	
B. Electrical Specifications	
1. Pin assignment	
2. Absolute maximum ratings	
3. Electrical characteristics	
a. Typical operating conditions	
b. Display color vs. input data signals	
c. Input signal timing	
d. Display position	
e. Backlight driving conditions	
C. Optical specifications	
D. Reliability test items	
E. Safety	
F. Display quality	
G. Handling precaution	
H. Label	
I. Mechanical drawings	
Appendix	



SPEC NO. MT230DW01 V.3

PAGE 4/23

A. General specification

NO.	Item	Specification	Remark
1	Display resolution (pixel)	1,920(H) X 1,080(V), Full HD	
2	Active area (mm)	509.184(H) x 286.416(V)	
3	Screen size (inch)	23 inches diagonal	
4	Pixel pitch (mm)	0.2652(H) X 0.2652(V)	
5	Color configuration	R, G, B vertical stripe	
6	Overall dimension (mm)	534mm(H) x 311.7mm(V) 8.9mm(D) (Typ.)	
7	Weight (g)	2200 (Max)	
8	Surface treatment	Anti-Glare, Haze=25%, Hard coating (3H)	
9	Input color signal	8 bit LVDS	
10	Display colors	16.7M (6 bit with Hi-FRC)	
11	Color Saturation	80% NTSC	
12	Optimum viewing direction	6 o'clock	
13	Backlight	White LED	
14	RoHS & Halogen Free	RoHS & Halogen Free compliance	

B. Electrical specifications

1. Pin assignment

1.1. LVDS Connector

FOXCONN GS23302-0311S-7F or mechanical interface equivalent connector.

No	Symbol	Description
1	RxO0-	LVDS Differential data input Channel 0(-)
2	RxO0+	LVDS Differential data input Channel 0(+)
3	RxO1-	LVDS Differential data input Channel 1(-)
4	RxO1+	LVDS Differential data input Channel 1(+)
5	RxO2-	LVDS Differential data input Channel 2(-)
6	RxO2+	LVDS Differential data input Channel 2(+)
7	GND	Ground
8	RxOC-	LVDS Differential Clock input (-)
9	RxOC+	LVDS Differential Clock input (+)
10	RxO3-	LVDS Differential data input Channel 3(-)
11	RxO3+	LVDS Differential data input Channel 3(+)
12	RxE0-	LVDS Differential data input Channel 0(-)
13	RxE0+	LVDS Differential data input Channel 0(+)
14	GND	Ground
15	RxE1-	LVDS Differential data input Channel 1(-)
16	RxE1+	LVDS Differential data input Channel 1(+)
17	GND	Ground
18	RxE2-	LVDS Differential data input Channel 2(-)
19	RxE2+	LVDS Differential data input Channel 2(+)
20	RxEC-	LVDS Differential Clock input (-)
21	RxEC+	LVDS Differential Clock input (+)
22	RxE3-	LVDS Differential data input Channel 3(-)
23	RxE3+	LVDS Differential data input Channel 3(+)
24	GND	Ground
25	NC	No Connection
26	NC	No Connection
27	NC	No Connection
28	VCC	Power supply (+5.0V)
29	VCC	Power supply (+5.0V)
30	VCC	Power supply (+5.0V)

SPEC NO. MT230DW01 V.3

PAGE 6/23

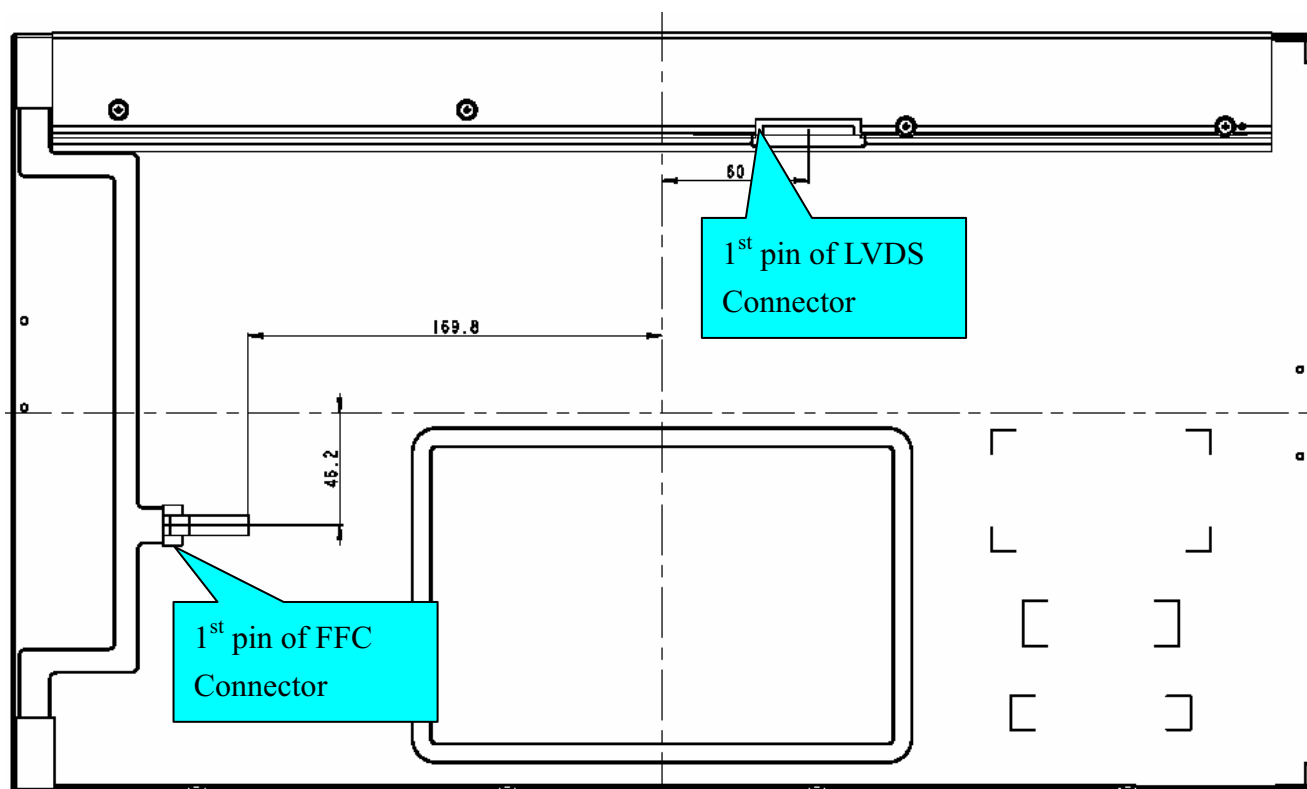

1.2 LED Light Bar FFC Cable

Pin No	Symbol	Description
1	RTN 1	Feedback
2	RTN 2	Feedback
3	RTN 3	Feedback
4	RTN 4	Feedback
5	NC	
6	VIN 1	LED power supply
7	VIN 2	LED power supply
8	NC	
9	RTN 5	Feedback
10	RTN 6	Feedback
11	RTN 7	Feedback
12	RTN 8	Feedback

2. Absolute maximum ratings

Parameter	Symbol	Values			Unit	Remark
		Min.	Typ.	Max.		
Power voltage	V_{CC}	-0.3	-	6.0	V	At 25°C
Input signal voltage	V_{LH}	-0.3	-	4.3	V	At 25°C
Operating temperature	T_{op}	0	-	50	°C	Note 1
Storage temperature	T_{ST}	-20	-	60	°C	Note 2

Note 1: The relative humidity must not exceed 90% non-condensing at temperatures of 40°C or less.
At temperatures greater than 40°C, the wet bulb temperature must not exceed 39°C.

Note 2: The unit should not be exposed to corrosive chemicals.

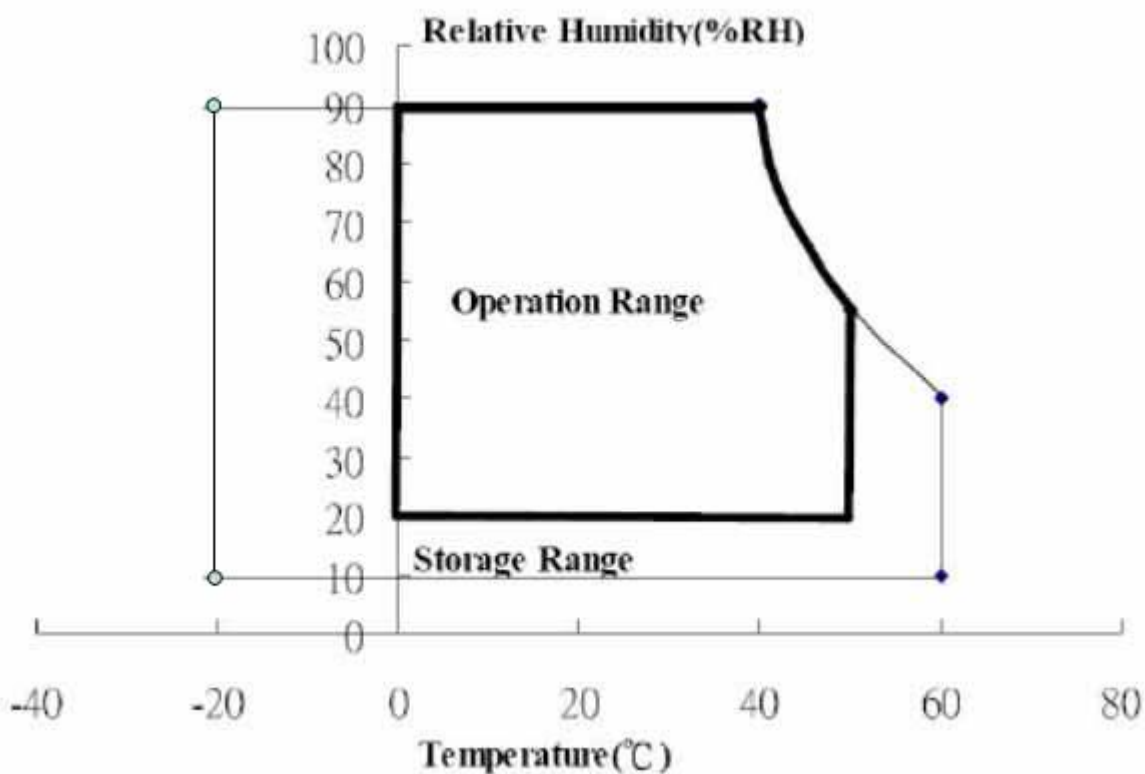

SPEC NO. MT230DW01 V.3

PAGE 8/23

3. Electrical characteristics

a. Typical operating conditions

Item		Symbol	Min.	Typ.	Max.	Unit	Remark
Input Voltage		V_{CC}	4.5	5	5.5	V	
Permissive Power Input Ripple		V_{RF}	-	-	400	mVp-p	
Input Current	Black	I_{CC}	-	1000	-	mA	Note 1
	White	I_{CC}	-	800	-		Note 2
	Mosaic	I_{CC}	-	950	-		Note 3
Rush Current		I_{Rush}	-	1.6	3	A	Note 4
Logic Input	Common Mode Voltage	VCM	-	1.2	-	V	
Voltage LVDS: IN+, IN-	Differential Input Voltage	VID	100	-	600	mV	
	Threshold Voltage (High)	VTH	-	-	100	mV	Note 5, 6
	Threshold Voltage (Low)	VTL	-100	-	-	mV	Note 5, 6

Note 1: The specified current is under the $V_{CC} = 5V$, $25^{\circ}C$, $f_v = 60Hz$ (frame frequency) condition whereas black pattern is displayed.

Note 2: The specified current is under the $V_{CC} = 5V$, $25^{\circ}C$, $f_v = 60Hz$ (frame frequency) condition whereas white pattern is displayed.

Note 3: The specified current is under the $V_{CC} = 5V$, $25^{\circ}C$, $f_v = 60Hz$ (frame frequency) condition whereas mosaic pattern (black & white [8*6]) is displayed.

White: 255 Gray

Black: 0 Gray

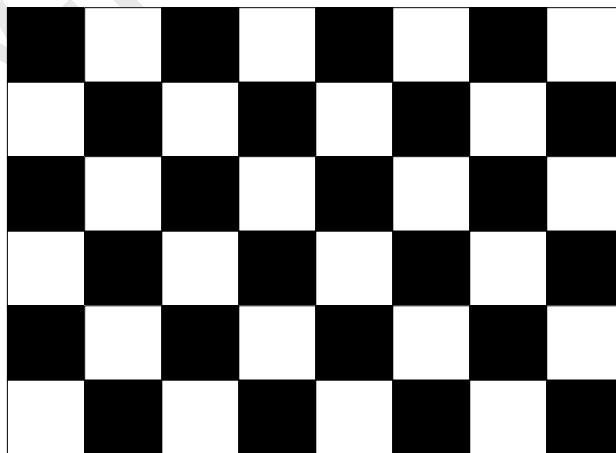

SPEC NO. MT230DW01 V.3

PAGE 9/23

Note 4: Test condition:

- (1). $V_{DD} = 5\text{ V}$, V_{DD} rising time = $470\ \mu\text{s} \pm 10\%$
- (2). Pattern: Mosaic pattern

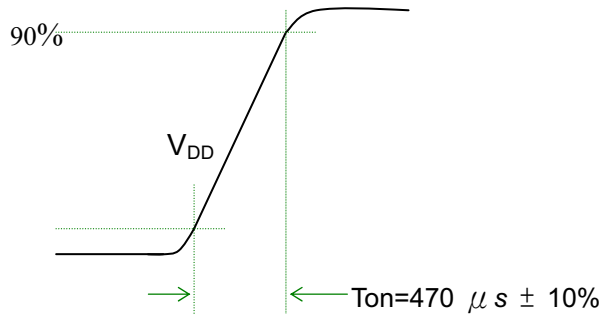

(3) Test circuit

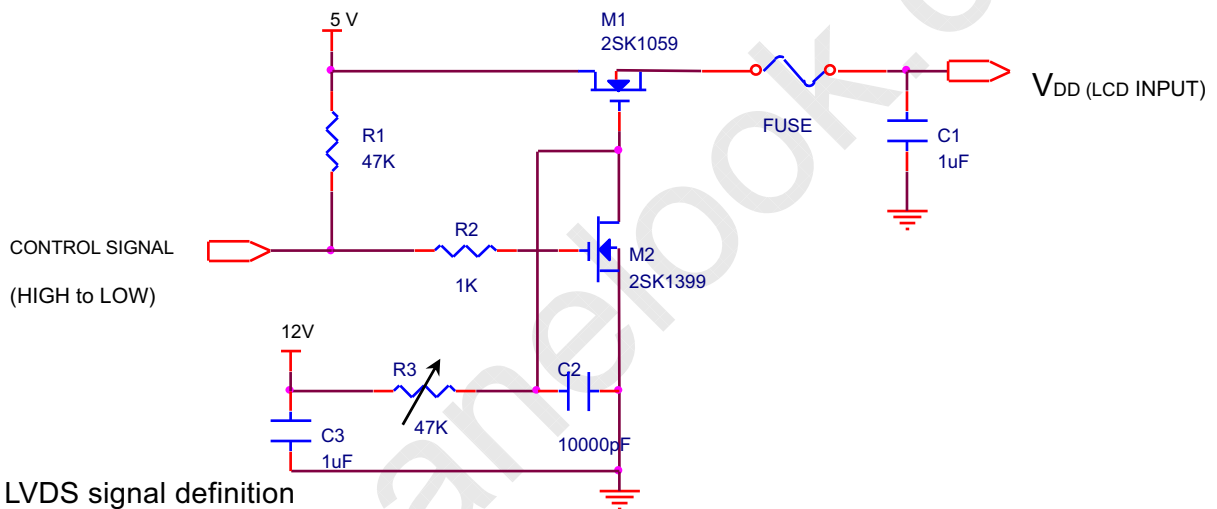

Note 5: LVDS signal definition

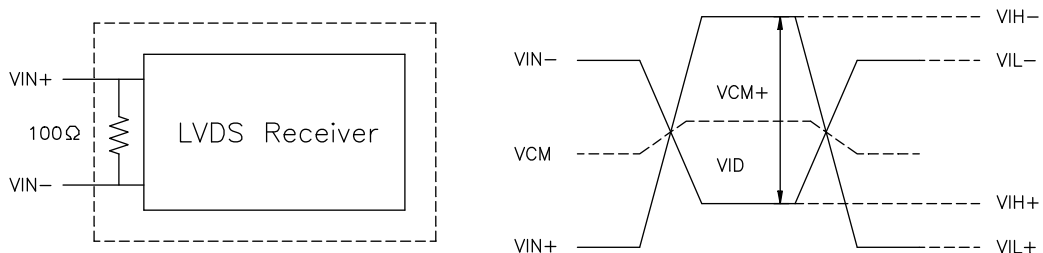
 VIN_+ = Positive differential DATA & CLK Input VIN_- = Negative differential DATA & CLK Input $VID = VIN_+ - VIN_-$, $\Delta V_{CM} = |V_{CM_+} - V_{CM_-}|$, $\Delta VID = |VID_+ - VID_-|$, $VID_+ = |VIH_- - VIH_-|$, $VID_- = |VIL_+ - VIL_-|$, $V_{CM} = (VIN_+ + VIN_-)/2$, $V_{CM_+} = (VIH_+ + VIH_-)/2$, $V_{CM_-} = (VIL_+ + VIL_-)/2$,

SPEC NO. MT230DW01 V.3

PAGE 10/23

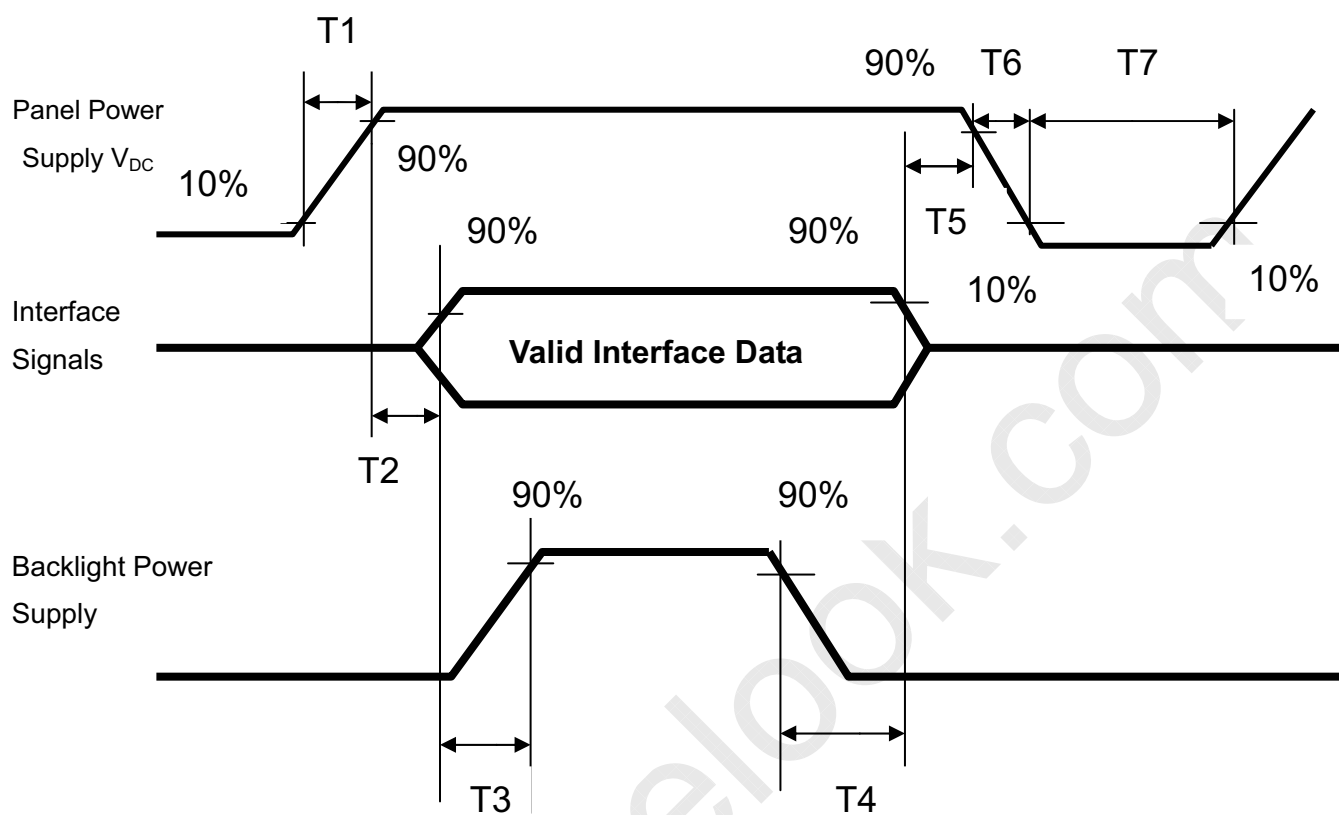
Note 6: Power on sequence for LCD V_{DD} 

Parameter	Value			Unit
	Min	Typ.	Max	
T1	0.1	-	10	ms
T2	0	30	50	ms
T3	200	250	-	ms
T4	100	250	-	ms
T5	0	20	50	ms
T6	0.1	-	10	ms
T7	1000	-	-	ms

b. Display color vs. input data signals

The brightness of each primary color (red, green and blue) is based on the 8-bit gray scale data input for the color; the higher the binary input, the brighter the color. The table below provides a reference for color versus data input.

Color	Input color data																							
	Red								Green								Blue							
	MSB				LSB				MSB				LSB				MSB				LSB			
	R7	R6	R5	R4	R3	R2	R1	R0	G7	G6	G5	G4	G3	G2	G1	G0	B7	B6	B5	B4	B3	B2	B1	B0
Basic colors	Black	0	0	0	0	0	0	0	0	0	0	0	0	0	0	0	0	0	0	0	0	0	0	0
	Red(255)	1	1	1	1	1	1	1	1	0	0	0	0	0	0	0	0	0	0	0	0	0	0	0
	Green(255)	0	0	0	0	0	0	0	0	1	1	1	1	1	1	1	0	0	0	0	0	0	0	0
	Blue(255)	0	0	0	0	0	0	0	0	0	0	0	0	0	0	0	1	1	1	1	1	1	1	1
	Cyan	0	0	0	0	0	0	0	0	1	1	1	1	1	1	1	1	1	1	1	1	1	1	1
	Magenta	1	1	1	1	1	1	1	1	0	0	0	0	0	0	0	1	1	1	1	1	1	1	1
	Yellow	1	1	1	1	1	1	1	1	1	1	1	1	1	1	1	0	0	0	0	0	0	0	0
	White	1	1	1	1	1	1	1	1	1	1	1	1	1	1	1	1	1	1	1	1	1	1	1
Red	Red(000) dark	0	0	0	0	0	0	0	0	0	0	0	0	0	0	0	0	0	0	0	0	0	0	0
	Red(001)	0	0	0	0	0	0	0	1	0	0	0	0	0	0	0	0	0	0	0	0	0	0	0
	Red(002)	0	0	0	0	0	0	1	0	0	0	0	0	0	0	0	0	0	0	0	0	0	0	0
	:	:	:	:	:	:	:	:	:	:	:	:	:	:	:	:	:	:	:	:	:	:	:	:
	Red(253)	1	1	1	1	1	1	0	1	0	0	0	0	0	0	0	0	0	0	0	0	0	0	0
	Red(254)	1	1	1	1	1	1	1	0	0	0	0	0	0	0	0	0	0	0	0	0	0	0	0
	Red(255) bright	1	1	1	1	1	1	1	1	0	0	0	0	0	0	0	0	0	0	0	0	0	0	0
Green	Green(000)dark	0	0	0	0	0	0	0	0	0	0	0	0	0	0	0	0	0	0	0	0	0	0	0
	Green(001)	0	0	0	0	0	0	0	0	0	0	0	0	0	0	1	0	0	0	0	0	0	0	0
	Green(002)	0	0	0	0	0	0	0	0	0	0	0	0	0	1	0	0	0	0	0	0	0	0	0
	:	:	:	:	:	:	:	:	:	:	:	:	:	:	:	:	:	:	:	:	:	:	:	:
	Green(253)	0	0	0	0	0	0	0	0	1	1	1	1	1	1	0	1	0	0	0	0	0	0	0
	Green(254)	0	0	0	0	0	0	0	0	1	1	1	1	1	1	0	0	0	0	0	0	0	0	0
	Green(255)bright	0	0	0	0	0	0	0	0	1	1	1	1	1	1	1	0	0	0	0	0	0	0	0
Blue	Blue(000) dark	0	0	0	0	0	0	0	0	0	0	0	0	0	0	0	0	0	0	0	0	0	0	0
	Blue(001)	0	0	0	0	0	0	0	0	0	0	0	0	0	0	0	0	0	0	0	0	0	0	1
	Blue(002)	0	0	0	0	0	0	0	0	0	0	0	0	0	0	0	0	0	0	0	0	0	1	0
	:	:	:	:	:	:	:	:	:	:	:	:	:	:	:	:	:	:	:	:	:	:	:	:
	Blue(253)	0	0	0	0	0	0	0	0	0	0	0	0	0	0	0	1	1	1	1	1	1	1	0
	Blue(254)	0	0	0	0	0	0	0	0	0	0	0	0	0	0	0	1	1	1	1	1	1	1	0
	Blue(255) bright	0	0	0	0	0	0	0	0	0	0	0	0	0	0	0	1	1	1	1	1	1	1	1

c. Input signal timing

Support Input Timing Table

	Item	Description	Min.	Typ.	Max.	Unit
Clock	Dclk	period	11.43	13.89	16.7	nS
		frequency	60	72	87.5	MHz
Vertical	T_{V_TOTAL}	V total line number	1090	1100	1160	T_{H_TOTAL}
	T_{V_DATA}	Data duration	1080	1080	1080	T_{H_TOTAL}
	T_{VB}	V-blank	10	20	80	T_{H_TOTAL}
	f_V	frequency	50	60	75	Hz
Horizontal	T_{H_TOTAL}	H total pixel number	1000	1088	1120	DClk
	T_{H_DATA}	Data duration	960	960	960	DClk
	T_{HB}	H-blank	40	128	160	DClk

Note: Because this module is operated by DE mode only, Hsync and Vsync input signals should be set to low Logic level or ground. Otherwise, this module would operate abnormally.

INPUT SIGNAL TIMING DIAGRAM

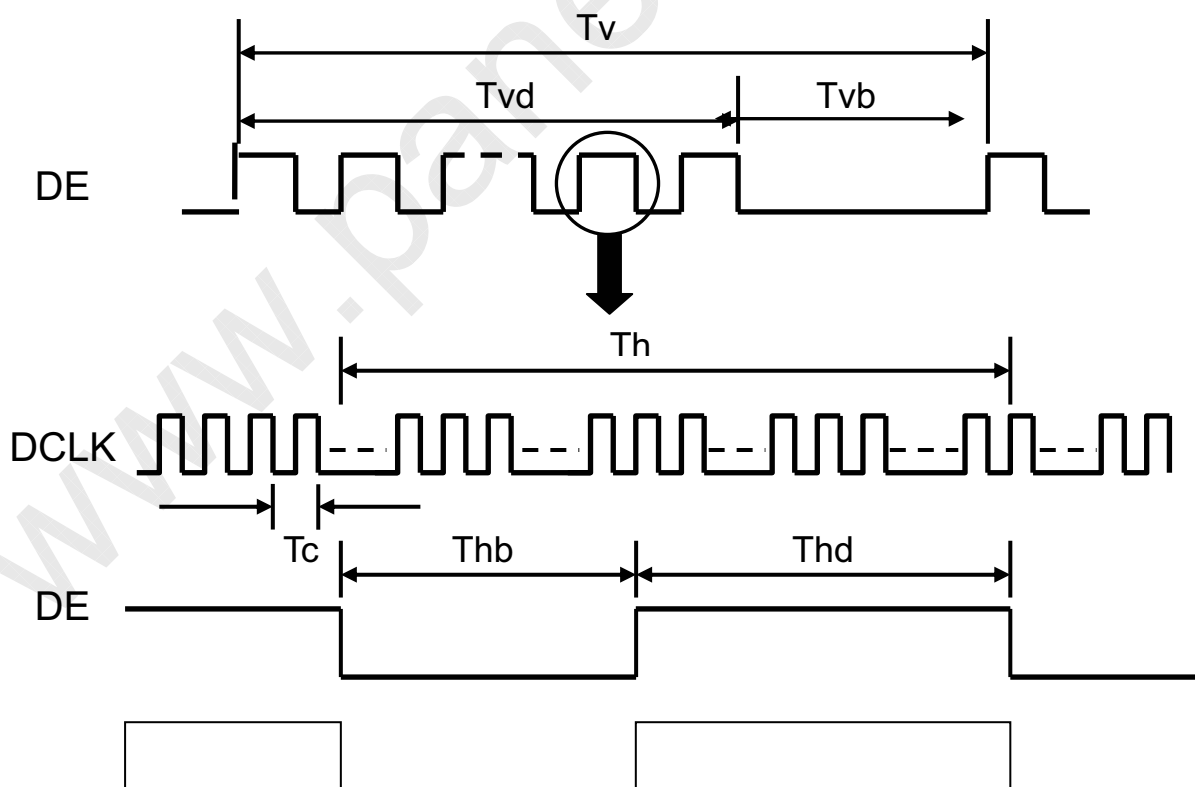

SPEC NO. MT230DW01 V.3

PAGE 13/23

d. Display Position

D(1,1)	D(2,1)	D(960,1)	D(1919,1)	D(1920,1)
D(1,2)	D(2,2)	D(960,2)	D(1919,2)	D(1920,2)
⋮	⋮	⋮	⋮	⋮
D(1,540)	D(2,540)	D(960,540)	D(1919,540)	D(1920,540)
⋮	⋮	⋮	⋮	⋮
D(1,1079)	D(2,1079)	D(960,1079)	D(1919,1079)	D(1920,1979)
D(1,1080)	D(2,1080)	D(960,1080)	D(1919,1080)	D(1920,1080)

e. Backlight Unit

e.1 Absolute Maximum Ratings (1 Module LED Circuit)

Item	Value		Unit	Note
Forward current	If	30	mA	1Block / PCB
	Ifp	MAX 320	mA	tp <= 10 ms, Duty cycle = 1/10 1Block / PCB
Forward Voltage	Vf	Max 72	V	1Block(20LEDs) / PCB
		Vfp	Max 98	V
Storage temperature.		-30 ... +70	°C	
Storage humidity		95%, 60deg		
Operating temperature.		-20 ... +70	°C	
Operating humidity		95%, 50deg		

e.2 Electrical & Optical Characteristics (at Ta=25 degree)

Item	Symbol	Min.	Typ.	Max.	Condition	Unit
Brightness	Nit		TBD		IF=120mA (Avg 2point)	nit
Viewing Angle	2θ1/2		TBD		-	deg
Color Uniformity	ΔC	CIE X,Y = ±0.01			(Δ2point)	-
Brightness Uniformity	ΔB	MIN / MAX > 0.85 (@2point)			IF=120mA	-

e.3 LED Light Bar Characteristics

Parameter	Symbol	Value			Unit	Note
		Min.	Typ.	Max.		
Light Bar Input Voltage	VLED	61	64	67	V _{DC}	(Duty 100%)
Light Bar Input Current	I _{LED}		30	320	mA _{DC}	Note 1, 2, 3
Power Consumption	P _{LED}			23.04	W	Note 4
LED Life Time	LBL	---	30000	---	Hrs	Note 5

Note 1: There are two Light Bars, and the specified current is input LED chip 100% duty current.

Note 2: The sensing current of each Bar is 30mA.

SPEC NO. MT230DW01 V.3

PAGE 14/23

Note 3: Each light bar have four current sensing strings, so that each light bar input current is 30mA.
 (30mA x 4 Bar(top) + 30mA x 4 Bar(Bottom)) = 240mA (Typ.)

Note 4: PLED = ILED × VLED.

Note 5: The life time is determined as the time at which luminance of the LED becomes 50% of the initial brightness or not normal lighting at the current $I_{LED}=120mA$ on condition of continuous operating at $25\pm 2^{\circ}C$.

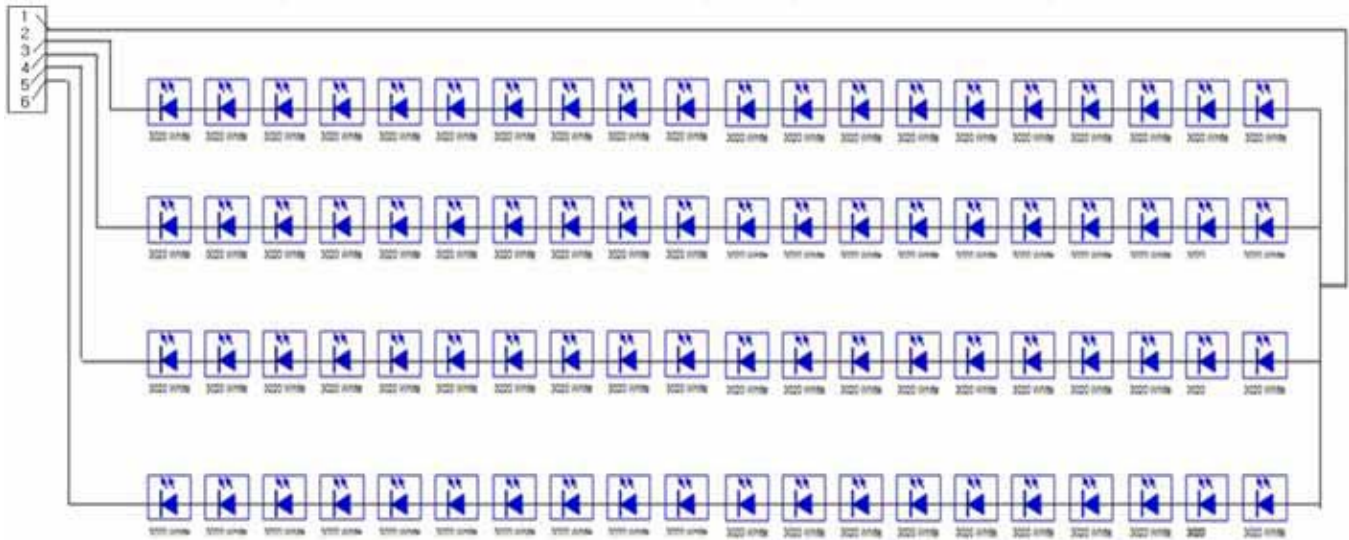

Pin No : 1(Vin) / 2(NC) / 3(Feedback) / 4(Feedback) / 5(Feedback) / 6(Feedback)

www.panelook.com

C. Optical specifications

Item	Symbol	Condition	Specification			Unit	Remark
			Min.	Typ.	Max.		
Response time	Tr	$\theta = 0^\circ$	-	1.5	3	ms	Note 2
	Tf		-	3.5	7		
	Tr+Tf		-	5	10		
Contrast ratio	CR	$\theta = 0^\circ$	700	1000	-		Note 1,3
Viewing angle	Top	$CR \geq 10$	70	80	-	deg.	Note 1,3,5
		$CR \geq 5$	75	85	-		
	Bottom	$CR \geq 10$	70	80	-		
		$CR \geq 5$	75	85	-		
	Left	$CR \geq 10$	75	85	-		
		$CR \geq 5$	80	89	-		
	Right	$CR \geq 10$	75	85	-		
		$CR \geq 5$	80	89	-		
Brightness (Center)	Y_L		200	250	-	nit	Note 1,4
Color chromaticity(CIE)	Wx	$\theta = 0^\circ$	-0.03	0.313	+0.03		Note 1
	Wy			0.329			
	Rx			0.640			
	Ry			0.330			
	Gx			0.285			
	Gy			0.630			
	Bx			0.150			
	By			0.060			
White uniformity (9 points)	δW		0.75	-	-		Note 1,6
Cross talk	Ct		-	-	2%		Note 7

Note: Ambient temperature = 25°C.

To be measured in dark room after backlight warm up 30 minutes.

Note 1: To be measured with a viewing cone of 2° by Topcon luminance meter BM-5A.

Note 2: Definition of response time:

The output signals of BM-7 are measured when the input signals are changed from "Black" to "White" (falling time) and from "White" to "Black" (rising time), respectively. The response time interval is between the 10% and 90% of amplitudes. Refer to figure as below.

SPEC NO. MT230DW01 V.3

PAGE 16/23

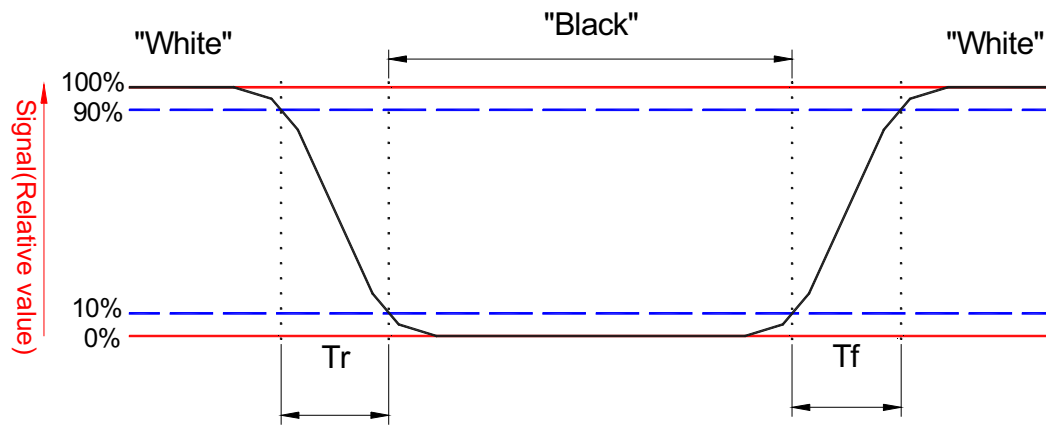

Note 3: Definition of contrast ratio:

Contrast ratio is calculated by the following formula.

$$\text{Contrast ratio (CR)} = \frac{\text{Brightness on the "white" state}}{\text{Brightness on the "black" state}}$$

Note 4: Driving conditions for LED: White LED IL = 30mA/rms, Vf = 60V

Note 5: Definition of viewing angle

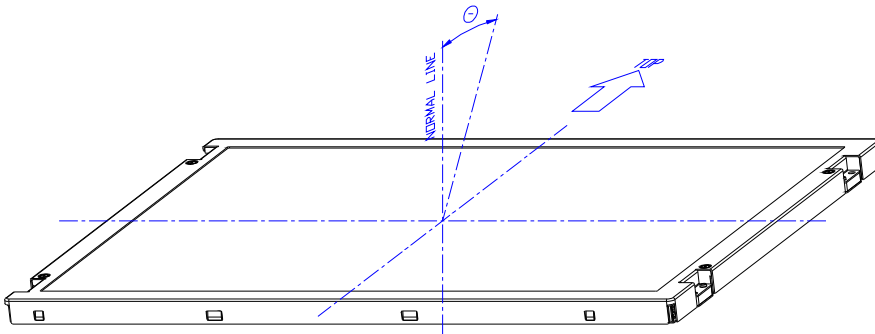

Note 6: Definition white uniformity:

Luminance are measured at the following nine points (P1~P9).

$$\delta_w = \frac{\text{Minimum Brightness of nine points (P1~P9)}}{\text{Maximum Brightness of nine points (P1~P9)}}$$

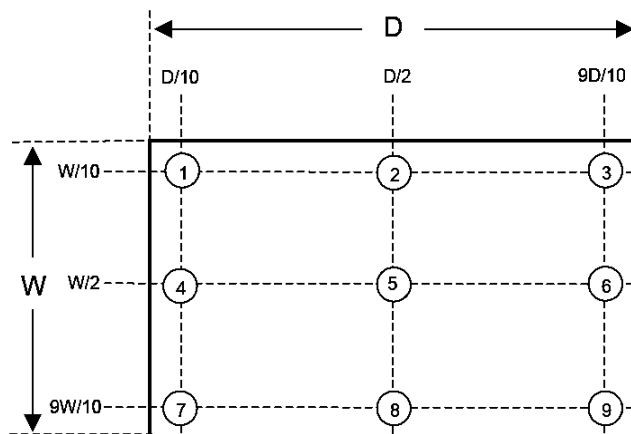

Note 7:

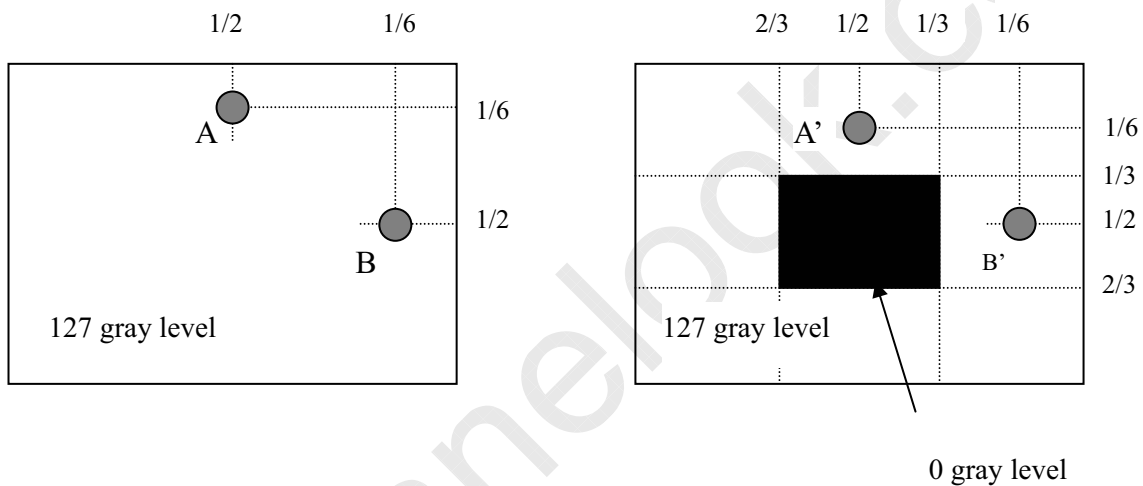

$|L_A - L_{A'}| / L_A \times 100\% = 2\% \text{ max.}$, L_A and $L_{A'}$ are brightness at location A and A'

$|L_B - L_{B'}| / L_B \times 100\% = 2\% \text{ max.}$, L_B and $L_{B'}$ are brightness at location B and B'

Note 10: Optical characteristic measurement setup.

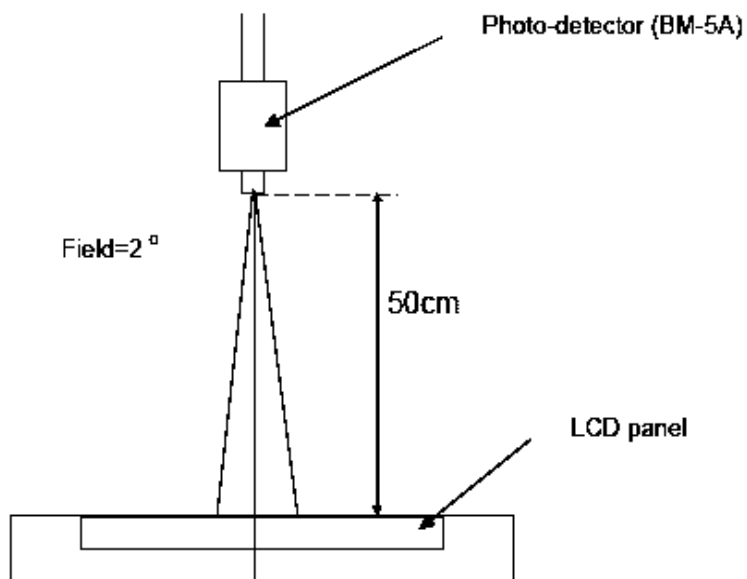

**D. Reliability test items**

Test Item	Test Condition	Judgment	Remark
High temperature storage	60°C, 240Hrs	Note 1	Note 2
Low temperature storage	-20°C, 240Hrs	Note 1	Note 2
High temperature & high humidity operation	40°C, 90%RH, 240Hrs (No condensation)	Note 1	Note 2
High temperature operation	50°C, 240Hrs	Note 1	Note 2
Low temperature operation	0°C, 240Hrs	Note 1	Note 2
Thermal Shock (non-operation)	-20 °C~60 °C, 1hrs, 3mins, 1hrs, 100Cycles	Note 1	Note 2
Electrostatic discharge (ESD) (non-operation)	Contact: +/-8kV, 150pF(330ohms), 25 times/1 point, 1 time/1 sec Air discharge: +/-15kV, 150pF(330ohms), 25 times/1 point, 1 time/1 sec	Note 1	Note 2
Vibration (non-operation)	Vibration level : 1.5G Bandwidth : 10-300Hz Waveform : sine wave, sweep rate : 10min 30 min for each direction X, Y, Z (1.5 Hrs in total)	Note 1	Note 2
Mechanical Shock (non-operation)	Shock level : 50G, 11ms Waveform : Half sine wave Direction : ±X, ±Y, ±Z One time each direction	Note 1	Note 2
MTBF Demonstration	50,000 hours with confidence level 90%	Note 1	Note 3

Note1: Pass: Normal display image with no obvious non-uniformity and no line defect.

Partial transformation of the module parts should be ignored.

Fail: No display image, obvious non-uniformity, or line defects.

Note2: Evaluation should be tested after storage at room temperature for two hours.

Note 3: The MTBF calculation is based on the assumption that the failure rate distribution meets the Exponential Model.



SPEC NO. MT230DW01 V.3

PAGE 19/23

E. Safety

(1). Sharp Edge Requirements

There will be no sharp edges or corners on the display assembly that could cause injury.

(2). Materials

a. Toxicity

There will be no carcinogenic materials used anywhere in the display module. If toxic materials are used, they will be reviewed and approved by the responsible InnoLux Toxicologist.

b. Flammability

All components including electrical components that do not meet the flammability grade UL94-V1 in the module will complete the flammability rating exception approval process. The printed circuit board will be made from material rated 94-V1 or better. The actual UL flammability rating will be printed on the printed circuit board.

c. Capacitors

If any polarized capacitors are used in the display assembly, provisions will be made to keep them from being inserted backwards.

F. Display quality

The display quality of the color TFT-LCD module should be in compliance with the Innolux's Incoming inspection standard.

G. Handling precaution

The Handling of the TFT-LCD should be in compliance with the Innolux's handling principle standard.



SPEC NO. MT230DW01 V.3

PAGE 20/23

H. Panel Label

(1). Module Label

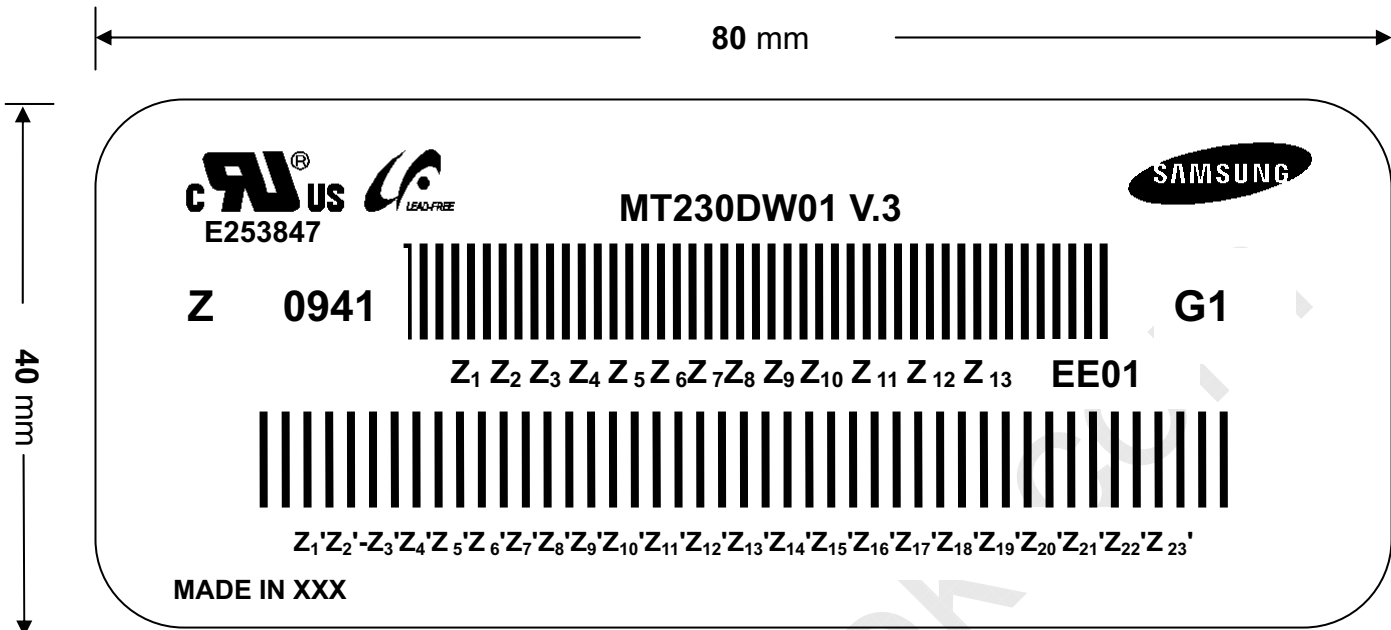

(a). Model Number: MT230DW01 V.3

(b). Customer Grade Mark : Z

(c). INL Grade: G1 (Code of grade: 1,2,3,5,E)

(d). Week Code: 0941 (YY,WK)

(e). Revision Code: EE01 (Make information + Minor Revision)

(f). Serial ID I: Z₁ Z₂ Z₃ Z₄ Z₅ Z₆ Z₇ Z₈ Z₉ Z₁₀ Z₁₁ Z₁₂ Z₁₃

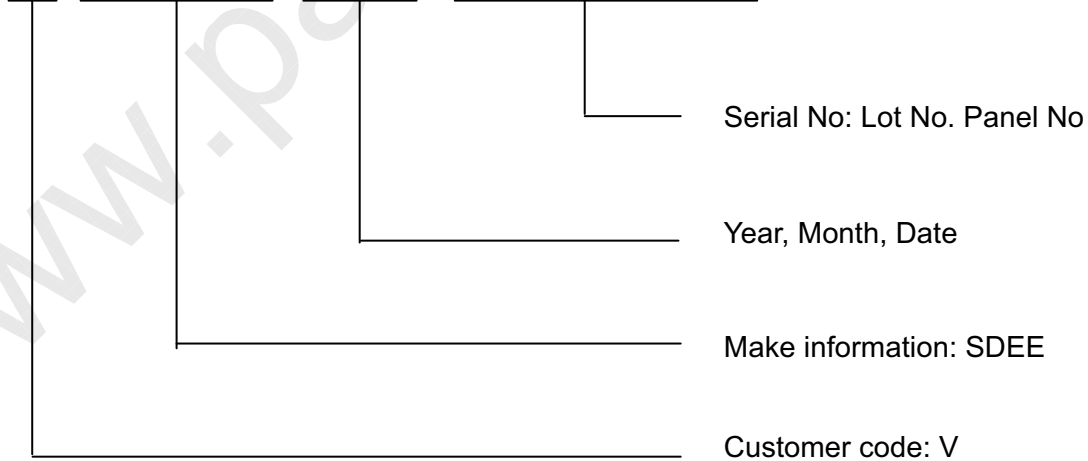

(g). Serial ID II: PPID (23 digits)



SPEC NO. MT230DW01 V.3

PAGE 21/23

(2) Carton Label

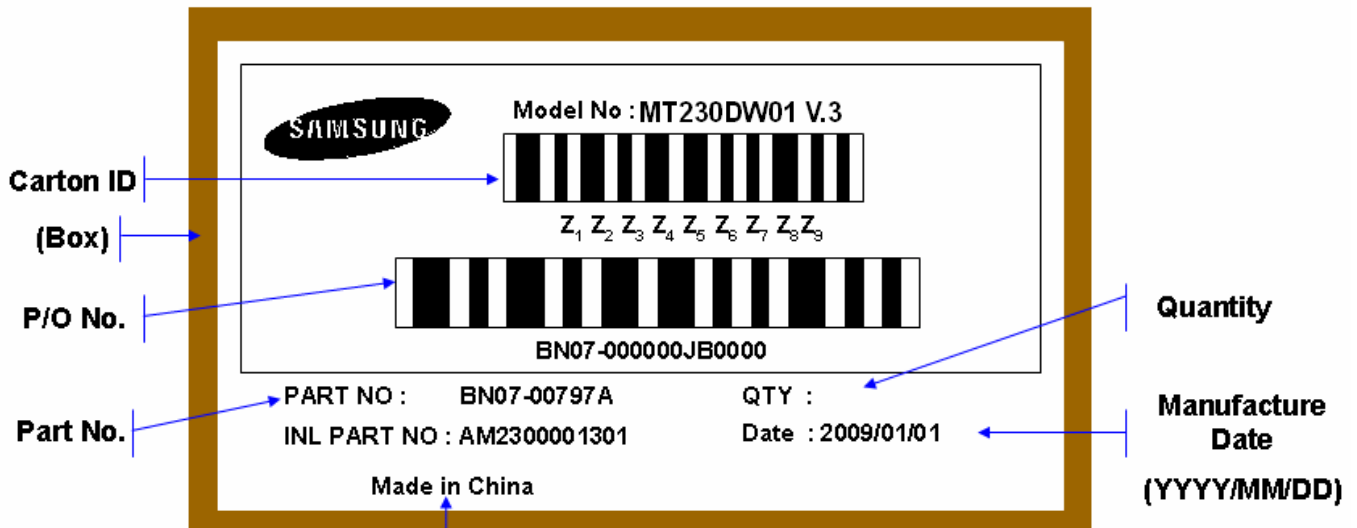

The Place of Origin

(a). Model No. : MT230DW01 V.3

(b). Part No. : BN07-00797A

(c). INL Part No. : AM2300001301

(d). Packing Q'ty: 7 pcs

(e). Date: Manufacture Date

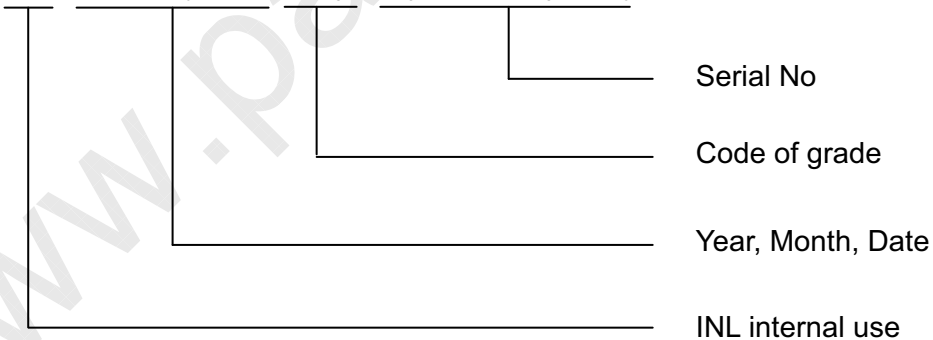
(f). Carton ID: Z₁ Z₂ Z₃ Z₄ Z₅ Z₆ Z₇ Z₈ Z₉

Carton ID includes the information as below:

(d-1). Manufacture Date: Year: 0~9, for 2000 ~2009

Month: 1~9 & A~C for Jan. ~ Dec.

Date: 1~9 & A~Z (exclude I, O, Q, U) for 1st~31th

(d-2). Code of grade: 1, 2, 3, 5, E

(d-3). Serial No: Module packing sequence no.

(g). P/O No. : Customer P/O number.

I. ME Drawing



SPEC NO. MT230DW01 V.3

PAGE 22/23



2D File

