



MODEL: MT3651A01-1

Ver. 1.1

Date: 04 Jun. 2012

Customer's Approval	CSOT
Signature _____ Date _____	Approved By Product Director Date _____ Name: Richard Lung Signature: _____
	Reviewed By PM Manager Date _____ Name: Aaron Tu Signature: _____
	Reviewed By Project Leader Date _____ Name: SF Chen Signature: _____
	Reviewed By PM Date _____ Name: Julie Wu Signature: _____

Contents

Revision History	4
1. General Description	5
1.1 Product Features	5
1.2 Overview.....	5
1.3 General Information.....	5
2. Absolute Maximum Ratings	6
2.1 Absolute Maximum Ratings	6
2.2 Environment Requirement	6
2.3 Package Storage	7
3. Electrical Specification	8
3.1 Electrical Characteristics	8
3.1.1 Power Consumption.....	8
3.1.2 LVDS Characteristics.....	9
3.2 Backlight Converter Unit.....	10
3.2.1 LED Converter Electrical Characteristics.....	10
3.2.2 LED Converter Power Sequence	11
4. Input Terminal Pin Assignment	12
4.1 TFT LCD Module	12
4.2 Converter Unit	14
4.2.1 Converter Input Connector Pin Definition.....	14
4.3 Block Diagram of Interface	15
4.4 LVDS Interface	15
4.4.1 VESA Format.....	15
4.4.2 JEIDA Format.....	15
4.5 Color Data Input Assignment	16
5. Interface Timing.....	17
5.1 Timing Table	17
5.2 Power On/Off Sequence	18
6. Optical Characteristics	19
6.1 Measurement Conditions	19
6.2 Optical Specifications	20
7. Mechanical Characteristics	24
7.1 Mechanical Specification.....	24
7.2 Packing.....	26
7.2.1 Packing Specifications	26
7.2.2 Packing Method	26

8. Definition of Labels	28
8.1 Module Label.....	28
8.2 Carton Label	28
8.3 Pallet Lab	29
9. Precautions.....	30
9.1 Assembly and Handling Precautions	30
9.2 Safety Precautions.....	30

CSOT
Confidential

Revision History

Version	Date	Page (New)	Section	Description	Revision by
Ver. 1.1	04 Jun.2012	30	All	Preliminary Specification was First Issued.	Julie Wu

CSOT
Confidential

1. General Description

1.1 Product Features

- **HD Resolution (1366 x 768)**
- **Brightness: 300 cd/m²**
- **High Contrast Ratio: 3000:1**
- **Fast Response Time**
- **Color Saturation: 62% NTSC**
- **Ultra Wide Viewing Angle: 178° (H)/178° (V) (CR ≥ 10)**
- **Low Power Consumption: Typ. 36W**
- **DE (Data Enable) Mode**
- **LVDS (Low Voltage Differential Signaling) Interface**
- **RoHS Compliance**

1.2 Overview

MT3651A01-1 is a diagonal 36.5" color active matrix LCD module with edge LED backlight and 1ch-LVDS interface. This module is a transmissive type display operating in the normally black mode. It supports 1366 x 768 HD resolution and can display up to 16.7M colors (8-bit). Each pixel is divided into Red, Green and Blue sub-pixels which are arranged in horizontal stripe. The converter of backlight is built-in.

This module dedicates for LCD TV products and provides excellent performance which includes high contrast ratio, ultra wide viewing angle, low power consumption and high color depth.

1.3 General Information

Item	Specification	Unit	Note
Active Area	808.331 (H) x 454.464 (V)	mm	
Bezel Opening Area	815.3 (H) x 461.6 (V)	mm	
Outline Dimension	837.1 (H) x 490.5 (V) x 9.9 (D)	mm	D: From Bezel to Rear (Thinner)
Weight	5.8	kg	Typ.
Driving Scheme	a-Si TFT Active Matrix	-	
Number of Pixels	1366 x 768	pixel	
Pixel Pitch (Sub Pixel)	0.59175 (H) x 0.19725 (V)	mm	
Pixel Arrangement	RGB Horizontal Stripe	-	
Display Colors	16.7 M	color	8-bit
Display Mode	Transmissive Mode, Normally Black	-	
Surface Treatment	Anti-glare, Haze 2%, Hard Coating (3H)	-	
Luminance of White	300	cd/m ²	Center Point, Typ.

2. Absolute Maximum Ratings

2.1 Absolute Maximum Ratings ($T_A = 25 \pm 2 \text{ }^\circ\text{C}$)

The followings are maximum values which, if exceeded, may cause damage to the unit.

Item	Symbol	Value		Unit
		Min.	Max.	
Power Supply Voltage	V_{CC}	- 0.3	13.5	V
Input Signal Voltage	V_{IN}	- 0.3	3.6	V
Converter Input Voltage	V_{BL}	0	30	V
Control Signal Level	-	- 0.3	7.0	V

2.2 Environment Requirement

(1) Temperature and relative humidity range are shown as below.

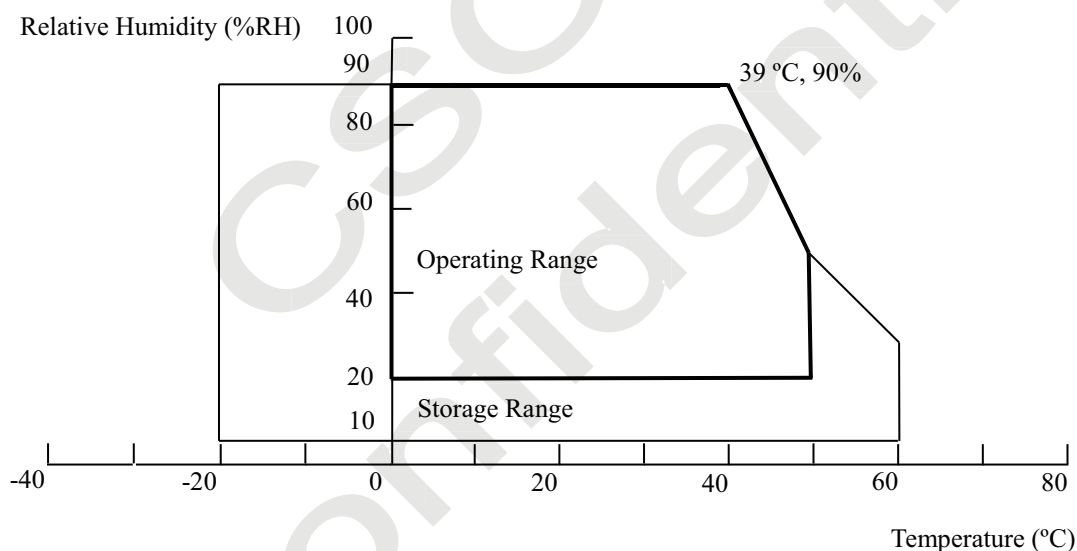

- (a) 90%RH maximum ($T_A < 39 \text{ }^\circ\text{C}$).
- (b) Wet-bulb temperature should be 39 °C maximum ($T_A > 39 \text{ }^\circ\text{C}$).
- (c) No condensation.

(2) The storage temperature is between - 20 °C to 60 °C, and the operating ambient temperature is between 0 °C to 50 °C.

The maximum operating temperature is based on the test condition that the surface temperature of display area is less than or equal to 65 °C with LCD module in a temperature controlled chamber alone. Thermal management should be considered in final product design to prevent the surface temperature of display area from being over 65 °C. The range of operating temperature may degrade in case of improper thermal management in the end product design.

(3) The TFT module including glass should be avoided any shock or vibration.

While testing shock and vibration, the fixture holding the module should be assured to be hard and rigid enough to prevent the module twisted or bent by the fixture. The test conditions should be less than:

Shock (Non-operating): 35 G, 11 ms, half sine wave, 1 time for $\pm X$, $\pm Y$, $\pm Z$.

Vibration (Non-operating): Random 1.0 Grms, 10 ~ 200 Hz, 10 min, 1 time for each X, Y, Z.

2.3 Package Storage

When storing modules as spares for a long time, please follow the precaution instructions:

- (1) Do not store the module in high temperature and high humidity for a long time. It is highly recommended to store the module with temperature from 0 °C to 35 °C in normal humidity.
- (2) The module shall be stored in a dark area and avoided to be exposed in direct sunlight or fluorescent light.

CSOT
Confidential

3. Electrical Specification

3.1 Electrical Characteristics

3.1.1 Power Consumption ($T_A = 25 \pm 2 \text{ }^\circ\text{C}$)

Parameter		Symbol	Value			Unit	Note
			Min.	Typ.	Max.		
Power Supply Voltage		V_{CC}	10.8	12.0	13.2	V	(1)
Rush Current		I_{RUSH}	-	-	3.0	A	(2)
Power Supply Current	White Pattern	I_{CC}	-	0.16	0.22	A	(3)
	Vertical Stripe	I_{CC}	-	0.28	0.40	A	
	Black Pattern	I_{CC}	-	0.16	0.22	A	

Note:

(1) The ripple voltage should be controlled less than 10% of V_{CC} .

(2) Measurement condition: V_{CC} rising time = 470 μs .

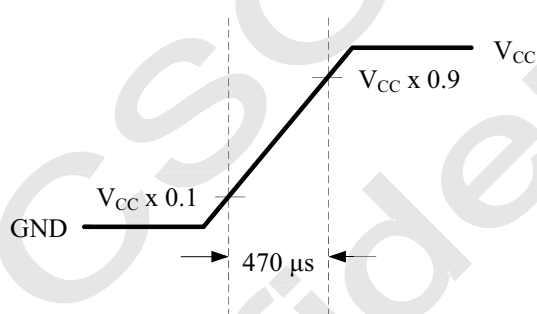

Fig. 3.1 V_{CC} rising time condition

(3) Measurement condition: $V_{CC} = 12 \text{ V}$, $T_A = 25 \pm 2 \text{ }^\circ\text{C}$, $F = 60 \text{ Hz}$. The test patterns are shown as below.

A. White Pattern



C. Black Pattern

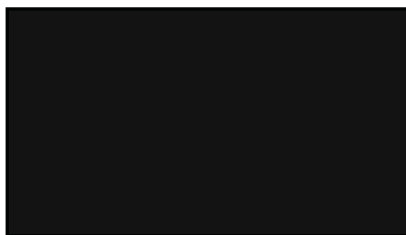

B. Vertical Pattern

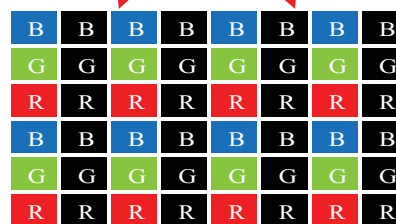
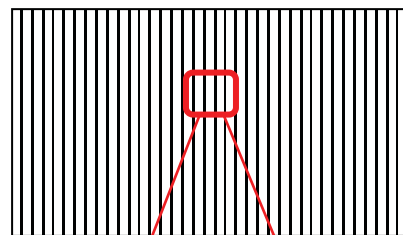

Fig. 3.2 Test patterns

3.1.2 LVDS Characteristics

Parameter	Symbol	Value			Unit	Note	
		Min.	Typ.	Max.			
LVDS Interface	Differential Input High Threshold Voltage	V_{TH}	+ 100	-	-	mV	(1)
	Differential Input Low Threshold Voltage	V_{TL}	-	-	- 100	mV	
	Common Input Voltage	V_{CM}	1.0	1.2	1.4	V	
	Differential Input Voltage	$ V_{ID} $	100	-	600	mV	
	Terminating Resistor	R_T	-	100	-	ohm	
CMOS Interface	Input High Threshold Voltage	V_{IH}	2.7	-	3.3	V	
	Input Low Threshold Voltage	V_{IL}	0.0	-	0.6	V	

Note:

(1) The LVDS input signal has been defined as follows:

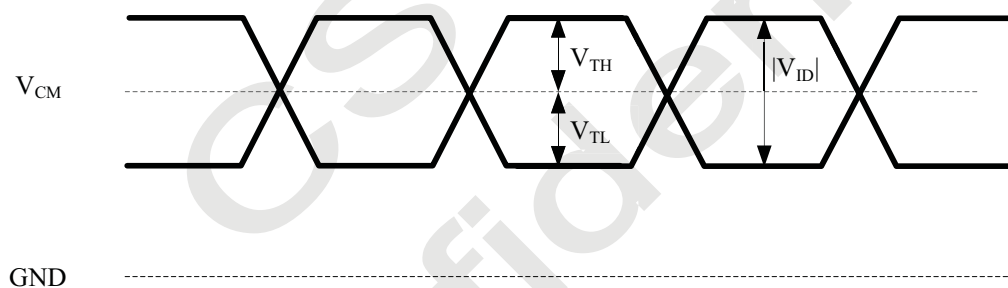

Fig. 3.3 LVDS input signal

3.2 Backlight Converter Unit

3.2.1 LED Converter Electrical Characteristics ($T_A = 25 \pm 2 \text{ }^\circ\text{C}$)

Parameter	Symbol	Condition	Value			Unit	Note	
			Min.	Typ.	Max.			
Power Consumption	P_{BL}	$V_{BL} = 24V$	-	32.4	37.0	W	(1)	
Input Voltage	V_{BL}	-	22.8	24.0	25.2	V		
Input Current	I_{BL}	$V_{BL} = 24V$	-	1.35	1.70	A	(1)	
Input Inrush Current	I_{RS-VIN}	$V_{BL} = 24V$	-	-	2.7	A	(2)	
					5.0	A		
On/Off Control Voltage	On	V_{BLON}	$V_{BL} = 24V$	2.5	-	5.0	V	
	Off		$V_{BL} = 24V$	0.0	-	0.8	V	
On/Off Control	-	I_{BLON}	$V_{BL} = 24V$	-	-	1.5	mA	
PWM Dimming Control Voltage	Max.	V_{P-DIM}	$V_{BL} = 24V$	2.5	-	5.0	V	
	Min.		$V_{BL} = 24V$	0.0	-	0.8	V	
External PWM Control Current	I_{P-DIM}	$V_{BL} = 24V$	-	-	2.0	mA		
PWM Dimming Frequency	F_{P-DIM}	$V_{BL} = 24V$	140	180	240	Hz		
Min Dimming Duty Ratio	D_{P-DIM}	$V_{BL} = 24V$	10	-	-	%	(3)	
DET Status Signal	DET HI	$V_{BL} = 24V$	Open Collector			-	(4)	
	DET Low	$V_{BL} = 24V$	0.0	-	0.8	V		
Input Impedance	R_{IN}	$V_{BL} = 24V$	300	-	-	Kohm		

Note:

(1) Dimming ratio = 100% (Max.) ($T_A = 25 \pm 5 \text{ }^\circ\text{C}$, Turn on for 45minutes).

(2) The measurement condition: V_{BL} rising time is 20 ms. (V_{BL} from 10% ~ 90%), the sequence diagram is shown as Fig. 3.4.

(3) Normal: 0 ~ 0.8V; Abnormal: Open collector.

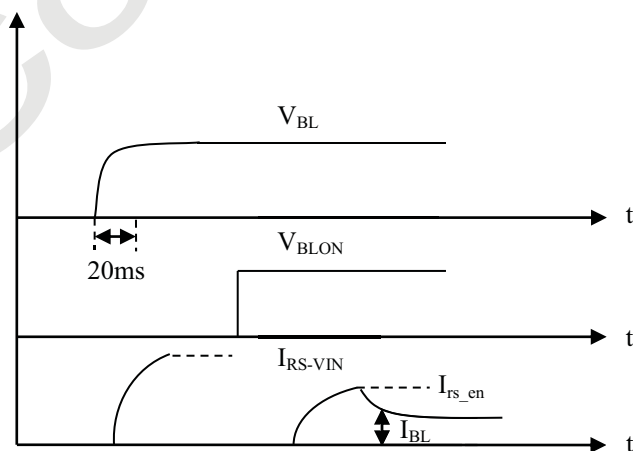

Fig. 3.4 The timing sequence diagram of inrush current measurement

3.2.2 LED Converter Power Sequence

No.	Symbol	Min.	Typ.	Max.	Unit	Remark
1	T1	20	-	-	ms	See Fig. 3.5
2	T2	500	-	-	ms	
3	T3	250	-	-	ms	
4	T4	0	-	-	ms	
5	T5	250	-	-	ms	

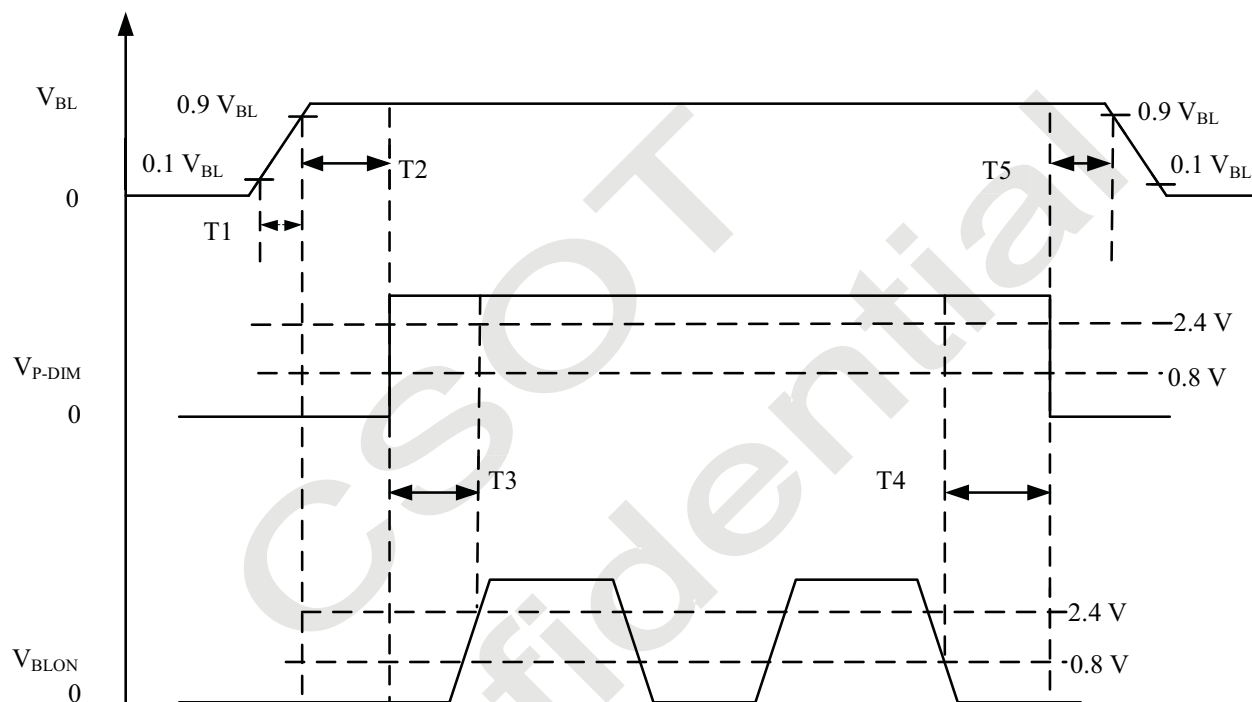

Fig. 3.5 The power sequence of V_{BL} and V_{BLON}

Attention:

The power sequence:

On = $V_{BL} > V_{P-DIM} \geq V_{BLON}$

Off = $V_{BLON} \geq V_{P-DIM} > V_{BL}$

4. Input Terminal Pin Assignment

4.1 TFT LCD Module

X + C Board CN1: 300B30-0000RA-M4 (Starconn) or equivalent (see Note (1))

Pin No.	Symbol	Description	Note
1	V _{CC}	Power Supply ,+ 12 V DC Regulated	
2	V _{CC}	Power Supply ,+ 12 V DC Regulated	
3	V _{CC}	Power Supply ,+ 12 V DC Regulated	
4	V _{CC}	Power Supply ,+ 12 V DC Regulated	
5	GND	Ground	
6	GND	Ground	
7	GND	Ground	
8	GND	Ground	
9	LVDS SEL	LVDS Data Format Selection	(2)
10	NC	For CSOT internal only	(3)
11	GND	Ground	
12	LV1N0	1st Channel LVDS Data Input (0-)	
13	LV1P0	1st Channel LVDS Data Input (0+)	
14	GND	Ground	
15	LV1N1	1st Channel LVDS Data Input (1-)	
16	LV1P1	1st Channel LVDS Data Input (1+)	
17	GND	Ground	
18	LV1N2	1st Channel LVDS Data Input (2-)	
19	LV1P2	1st Channel LVDS Data Input (2+)	
20	GND	Ground	
21	LVCK1N	1st Channel LVDS Clock Input (-)	
22	LVCK1P	1st Channel LVDS Clock Input (+)	
23	GND	Ground	
24	LV1N3	1st Channel LVDS Data Input (3-)	
25	LV1P3	1st Channel LVDS Data Input (3+)	
26	GND	Ground	
27	NC	For CSOT internal only	(3)
28	NC	For CSOT internal only	(3)
29	NC	For CSOT internal only	(3)
30	GND	Ground	

Note:

(1) The direction of pin assignment is shown as below:

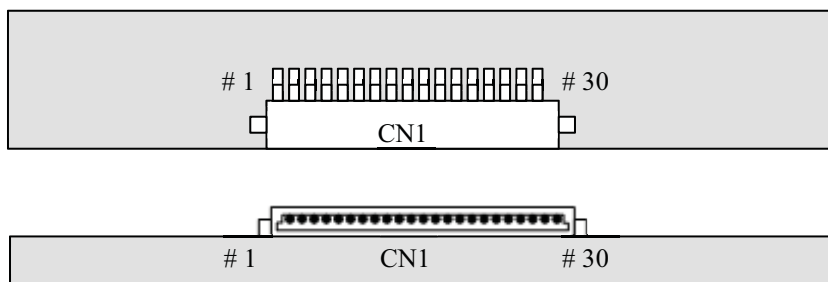

Fig. 4.1 LVDS connector direction sketch map

(2) High: connect to + 3.3 V → JEIDA format; Low: connect to GND or Open → VESA format.

(3) For CSOT internal only, please let it open.

4.2 Converter Unit

4.2.1 Converter Input Connector Pin Definition

Converter Board CNF1: 50308-0140N-002 (ACES) or equivalent (see 4.2 Note (1))

Pin No.	Symbol	Feature
1	V _{BL}	Power Supply, + 24V DC Regulated
2		
3		
4		
5		
6	GND	GND
7		
8		
9		
10		
11	DET	Normal (0 ~ 0.8V), Abnormal (Open Collector) (Recommend Pull high R > 10K, VDD = 3.3V)(Note (2))
12	BLON	Back Light On: High (2 ~ 5V); Back Light Off: Low (0 ~ 0.8V/GND)
13	NC	No Connection
14	P_DIM	PWM Dimming Control (Open for 100%)

Attention:

If the external PWM function is less than 5% dimming ratio, the judge conditions are as below:

(1) The direction of pin assignment is shown as below.

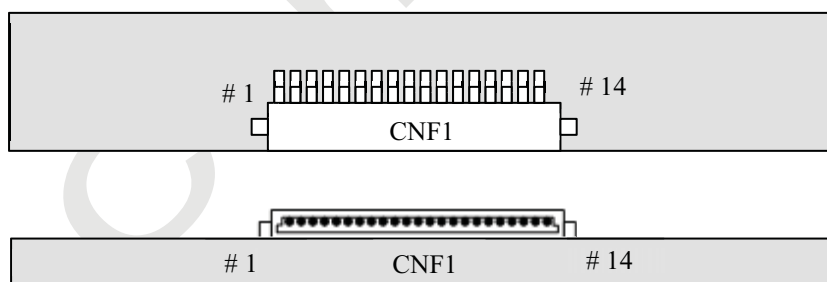
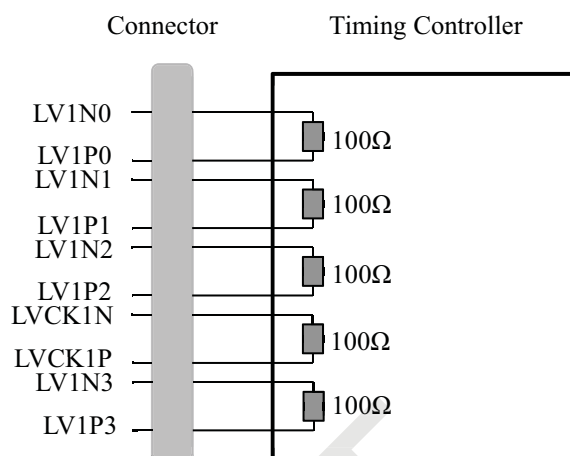

Fig. 4.2 Converter connector direction sketch map

(2) When open collector occur, the limit current resistor need to be connected to DET pin to prevent MOSFET from damage, the maximum drain current of MOSFET is 100mA.

4.3 Block Diagram of Interface



Attention:

- (1) LCD module uses a 100 ohms (Ω) resistor between positive and negative lines of each receiver input.
- (2) LVDS cable impedance shall be 50 ohms per signal line or about 100 ohms per twist-pair line respectively.

4.4 LVDS Interface

4.4.1 VESA Format (SELLVDS = L or Open)

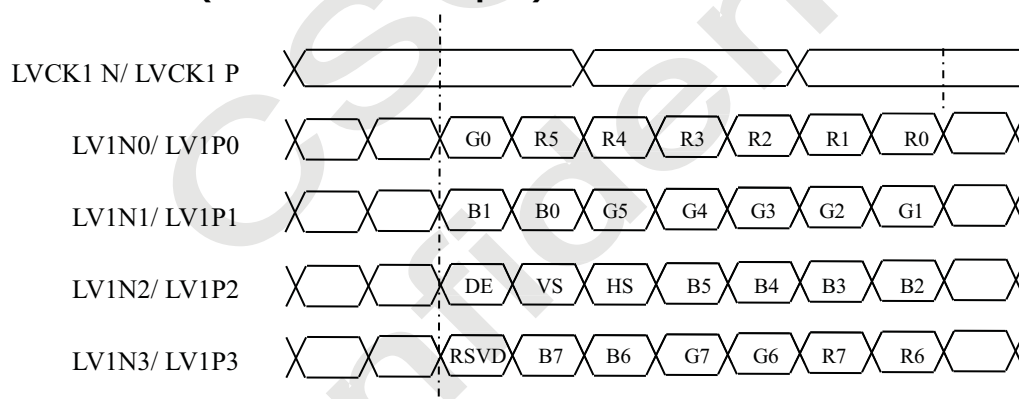

4.4.2 JEIDA Format (SELLVDS = H)

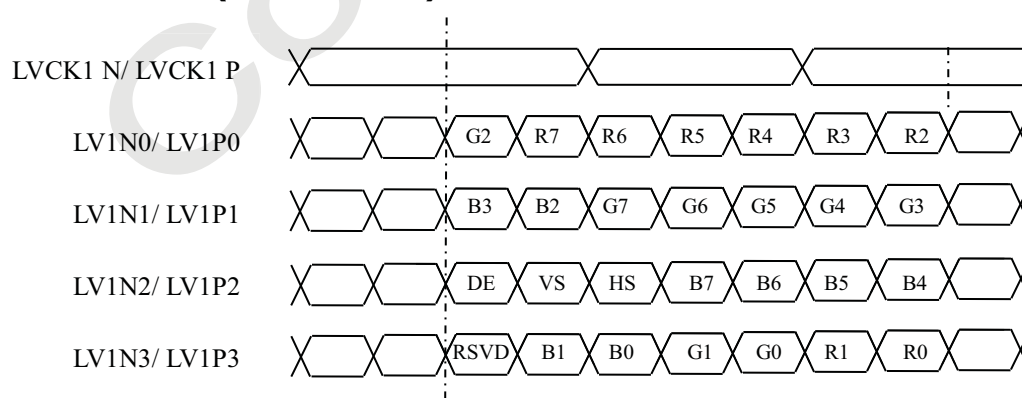

4.5 Color Data Input Assignment

The brightness of each primary color is based on the 8-bit gray scale data input for each color. The higher the binary input, the brighter the color. The table below provides the assignment of the color versus.

Data Input Color		Data Signal																							
		Red								Green								Blue							
		MSB				LSB				MSB				LSB				MSB				LSB			
		R7	R6	R5	R4	R3	R2	R1	R0	G7	G6	G5	G4	G3	G2	G1	G0	B7	B6	B5	B4	B3	B2	B1	B0
Basic Colors	Black	0	0	0	0	0	0	0	0	0	0	0	0	0	0	0	0	0	0	0	0	0	0	0	
	Red	1	1	1	1	1	1	1	1	0	0	0	0	0	0	0	0	0	0	0	0	0	0	0	
	Green	0	0	0	0	0	0	0	0	1	1	1	1	1	1	1	1	0	0	0	0	0	0	0	
	Blue	0	0	0	0	0	0	0	0	0	0	0	0	0	0	0	1	1	1	1	1	1	1	1	
	Cyan	0	0	0	0	0	0	0	0	1	1	1	1	1	1	1	1	1	1	1	1	1	1	1	
	Magenta	1	1	1	1	1	1	1	1	0	0	0	0	0	0	0	1	1	1	1	1	1	1	1	
	Yellow	1	1	1	1	1	1	1	1	1	1	1	1	1	1	1	0	0	0	0	0	0	0	0	
	White	1	1	1	1	1	1	1	1	1	1	1	1	1	1	1	1	1	1	1	1	1	1	1	
Gray Scale of Red	Red (0) / Dark	0	0	0	0	0	0	0	0	0	0	0	0	0	0	0	0	0	0	0	0	0	0		
	Red (1)	0	0	0	0	0	0	0	1	0	0	0	0	0	0	0	0	0	0	0	0	0	0		
	:	:	:	:	:	:	:	:	:	:	:	:	:	:	:	:	:	:	:	:	:	:	:		
	:	:	:	:	:	:	:	:	:	:	:	:	:	:	:	:	:	:	:	:	:	:	:		
	Red (254)	1	1	1	1	1	1	1	0	0	0	0	0	0	0	0	0	0	0	0	0	0	0		
Red (255)	1	1	1	1	1	1	1	1	0	0	0	0	0	0	0	0	0	0	0	0	0	0			
Gray Scale of Green	Green (0) / Dark	0	0	0	0	0	0	0	0	0	0	0	0	0	0	0	0	0	0	0	0	0	0		
	Green (1)	0	0	0	0	0	0	0	0	0	0	0	0	0	0	1	0	0	0	0	0	0	0		
	:	:	:	:	:	:	:	:	:	:	:	:	:	:	:	:	:	:	:	:	:	:	:		
	:	:	:	:	:	:	:	:	:	:	:	:	:	:	:	:	:	:	:	:	:	:	:		
	Green (254)	0	0	0	0	0	0	0	0	1	1	1	1	1	1	1	0	0	0	0	0	0	0		
Green (255)	0	0	0	0	0	0	0	0	1	1	1	1	1	1	1	0	0	0	0	0	0	0			
Gray Scale of Blue	Blue (0) / Dark	0	0	0	0	0	0	0	0	0	0	0	0	0	0	0	0	0	0	0	0	0	0		
	Blue (1)	0	0	0	0	0	0	0	0	0	0	0	0	0	0	0	0	0	0	0	0	0	1		
	:	:	:	:	:	:	:	:	:	:	:	:	:	:	:	:	:	:	:	:	:	:	:		
	:	:	:	:	:	:	:	:	:	:	:	:	:	:	:	:	:	:	:	:	:	:	:		
	Blue (254)	0	0	0	0	0	0	0	0	0	0	0	0	0	0	0	1	1	1	1	1	1	0		
Blue (255)	0	0	0	0	0	0	0	0	0	0	0	0	0	0	0	1	1	1	1	1	1	1			

Attention:

0: Low level voltage; 1: High level voltage.

5. Interface Timing

5.1 Timing Table (DE Only Mode)

Signal	Item	Symbol	Min.	Typ.	Max.	Unit	Note
LVDS Clock	Frequency	F_{CLK} ($= 1 / T_{CLK}$)	50.0	75.4	85.0	MHz	
Vertical Term	Frame Rate	F	47	60	63	Hz	
	Vertical Frequency	F_V	47.0	48.4	60.9	KHz	
	Total	T_V	784	806	1015	T_H	$T_V = T_{VD} + T_{VB}$
	Display	T_{VD}	768			T_H	
	Blank	T_{VB}	16	38	247	T_H	
Horizontal Term	Total	T_H	1460	1560	2000	T_{CLK}	$T_H = T_{HD} + T_{HB}$
	Display	T_{HD}	1366			T_{CLK}	
	Blank	T_{HB}	94	194	634	T_{CLK}	

Attention:

(1) The module is operated in DE only mode, H sync and V sync input signal have no effect on normal operation.

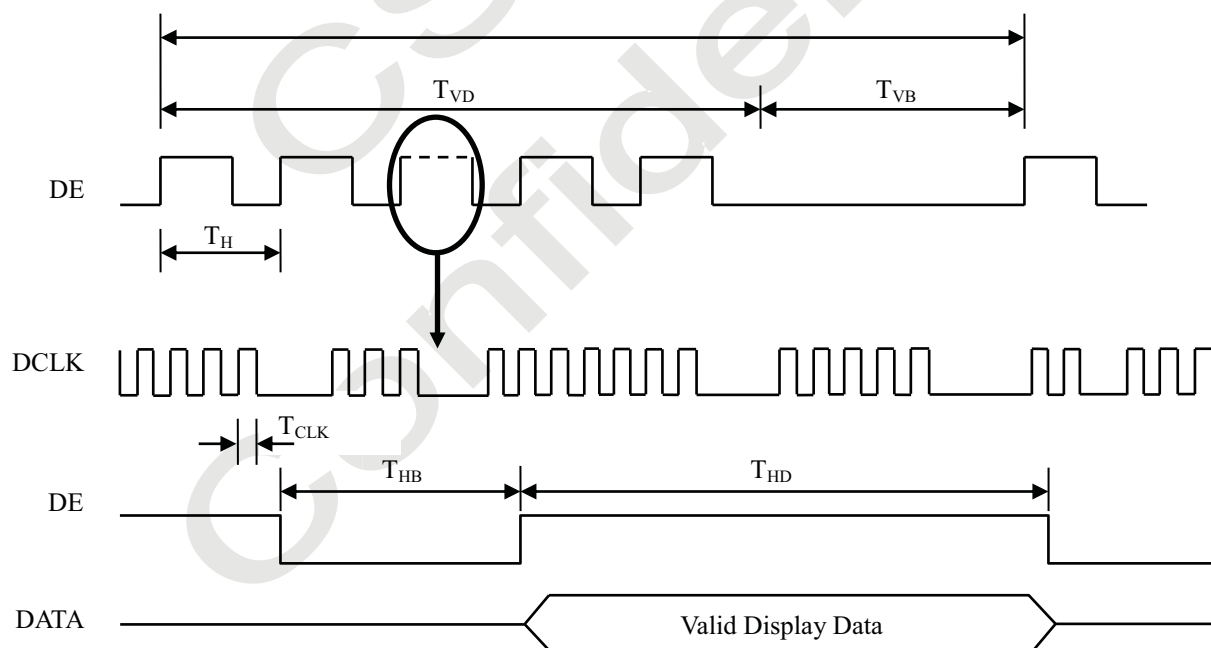

Fig. 5.1 Interface signal timing diagram

5.2 Power On/Off Sequence

To prevent a latch-up or DC operation of LCD module, the power on/off sequence should be as the diagram below.

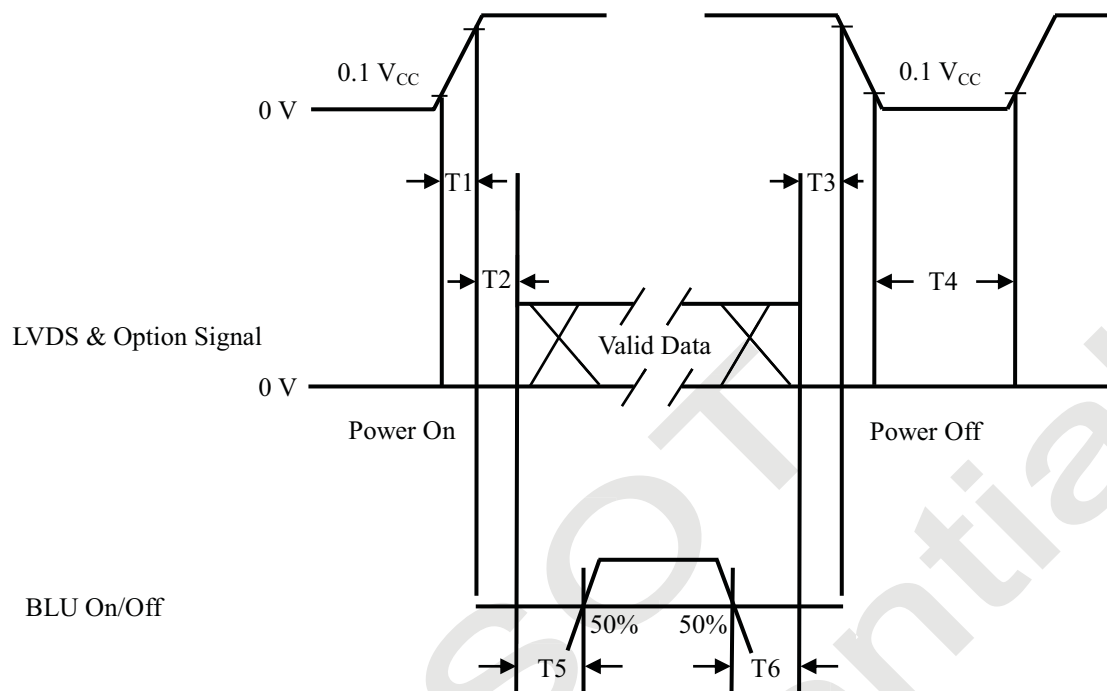

Fig. 5.2 Power On/Off Sequence

Parameter	Values			Unit
	Min.	Typ.	Max.	
T1	0.5	-	10.0	ms
T2	0	-	-	ms
T3	0	-	-	ms
T4	1000	-	-	ms
T5	500	-	-	ms
T6	100	-	-	ms

Attention:

- (1) The supply voltage of the external system for the module input should follow the definition of V_{CC} .
- (2) Apply the lightbar voltage within the LCD operation range. When the backlight turns on before the LCD operation or the LCD turns off before the backlight turns off, the display may momentarily become abnormal screen.
- (3) In case that V_{CC} is in off level, please keep the level of input signals on the low or high impedance. If $T2 < 0$, that may cause electrical overstress.
- (4) T4 should be measured after the module has been fully discharged between power off and on period.
- (5) Interface signal shall not be kept at high impedance when the power is on.

6. Optical Characteristics

6.1 Measurement Conditions

The table below is the test condition of optical measurement.

Item	Symbol	Value	Unit
Ambient Temperature	T_A	25 ± 2	$^{\circ}\text{C}$
Ambient Humidity	H_A	50 ± 10	% RH
LVDS Supply Voltage	V_{CC}	12	V
Driving Signal	Refer to the typical value in Chapter 3: Electrical Specification		
LED Driving Current	I_L	150	mA
Vertical Refresh Rate	F_R	60	Hz

To avoid abrupt temperature change during optical measurement, it's suggested to warm up the LCD module more than 45 minutes after lighting the backlight and in the windless environment.

To measure the LCD module, it is suggested to set up the standard measurement system as Fig. 6.1. The measuring area S should contain at least 500 pixels of the LCD module as illustrated in Fig. 6.2 (A means the area allocated to one pixel). In this model, for example, the minimum measuring distance Z is 370 mm when θ is 2 degree. Hence, 500 mm is the typical measuring distance. This measuring condition is referred to 301-2H of VESA FPDM 2.0 about viewing distance, angle, and angular field of view definition.

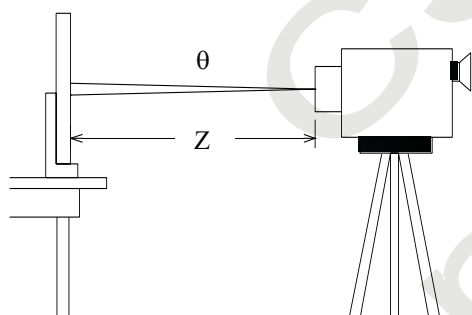

Fig. 6.1 The standard set-up system of measurement

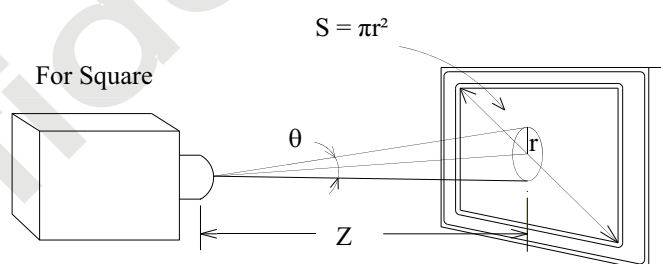

Fig. 6.2 The area S contains at least 500 pixels to be measured

$$N = \frac{S}{A} \geq 500\text{pixels}$$

N means the actual number of the pixels in the area S.

6.2 Optical Specifications

The table below of optical characteristics is measured by MINOLTA CS2000, MINOLTA CA310, ELDIM OPTI Scope-SA and ELDIM EZ Contrast in dark room.

Item		Symbol	Condition	Min.	Typ.	Max.	Unit	Note
Static Contrast Ratio		CR		2400	3000	-	-	(1) (2)
Response Time		T _L		-	6.5	12	ms	(3)
Center Luminance		L _W		250	300	-	cd/m ²	(2) (4)
Uniformity of White Screen		-		70	-	-	%	(2) (5)
Color Chromaticity (CIE1931)	Red	R _X		θ _H = 0°, θ _V = 0° Normal direction at center point of the LCD Module	Typ. - 0.03	0.611	Typ. + 0.03	-
		R _Y	0.333			-		
	Green	G _X	0.331			-		
		G _Y	0.606			-		
	Blue	B _X	0.153			-		
		B _Y	0.069			-		
	White	W _X	0.280			-		
		W _Y	0.290			-		
Color Gamut		CG	-	62	-	% NTSC		
Viewing Angle	Horizontal	θ _{H+}	CR ≥ 10	80	89	-	Deg.	(7)
		θ _{H-}		80	89	-		
	Vertical	θ _{V+}		80	89	-		
		θ _{V-}		80	89	-		

Note:

(1) Definition of static contrast ratio (CR):

It's necessary to switch off all the dynamic and dimming function when measuring the static contrast ratio.

$$\text{Static Contrast Ratio (CR)} = \frac{\text{CR-W}}{\text{CR-D}}$$

CR-W is the luminance measured by LMD (light-measuring device) at the center point of the LCD module with full-screen displaying white. The standard setup of measurement is illustrated in Fig. 7.3; CR-D is the luminance measured by LMD at the center point of the LCD module with full-screen displaying black. The LMD in this item is CS2000.

(2) The LMD in the item could be a spectroradiometer such as (KONICA MINOLTA) CS2000, CS1000(TOPCON), SR-UL2 or the same level spectroradiometer. Other display color analyzer (KONICA MINOLTA) CA210, CA310 or (TOPCON) BM-7 could be involved after being calibrated with a spectroradiometer on each stage of a product.

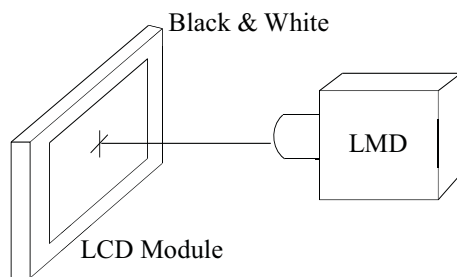

Fig. 6.3 The standard setup of CR measurement

(3) Response time T_L is defined as the average transition time in the response time matrix. The table below is the response time matrix in which each element $t_{X \text{ to } Y}$ is the transition time from luminance ratio X to Y. X and Y are two different luminance ratios among 0%, 25%, 50%, 75%, and 100% luminance. The transition time $t_{X \text{ to } Y}$ is defined as the time taken from 10% to 90% of the luminance difference between X and Y ($X < Y$) as illustrated in Fig.6.4. When $X > Y$, the definition of $t_{X \text{ to } Y}$ is the time taken from 90% to 10% of the luminance difference between X and Y. The response time is optimized on refresh rate $F_r = 60\text{Hz}$.

Measured Transition Time		Luminance Ratio of Previous Frame				
		0%	25%	50%	75%	100%
Luminance Ratio of Current Frame	0%		$t_{25\% \text{ to } 0\%}$	$t_{50\% \text{ to } 0\%}$	$t_{75\% \text{ to } 0\%}$	$t_{100\% \text{ to } 0\%}$
	25%	$t_{0\% \text{ to } 25\%}$		$t_{50\% \text{ to } 25\%}$	$t_{75\% \text{ to } 25\%}$	$t_{100\% \text{ to } 25\%}$
	50%	$t_{0\% \text{ to } 50\%}$	$t_{25\% \text{ to } 50\%}$		$t_{75\% \text{ to } 50\%}$	$t_{100\% \text{ to } 50\%}$
	75%	$t_{0\% \text{ to } 75\%}$	$t_{25\% \text{ to } 75\%}$	$t_{50\% \text{ to } 75\%}$		$t_{100\% \text{ to } 75\%}$
	100%	$t_{0\% \text{ to } 100\%}$	$t_{25\% \text{ to } 100\%}$	$t_{50\% \text{ to } 100\%}$	$t_{75\% \text{ to } 100\%}$	

$t_{X \text{ to } Y}$ means the transition time from luminance ratio X to Y.

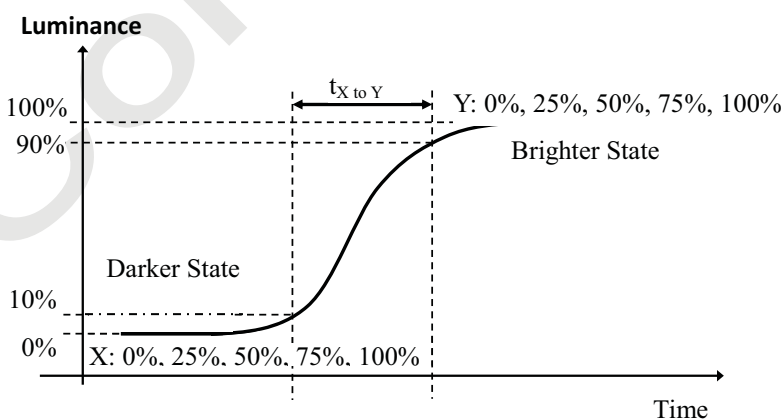

Fig. 6.4 The definition of $t_{X \text{ to } Y}$

All the transition time is measured at the center point of the LCD module by ELDIM OPTI Scope-SA.

(4) Definition of center luminance (L_w):

The luminance is measured at the center point of the LCD module with full-screen displaying white. Fig. 7.5 shows the standard setup of luminance measurement.

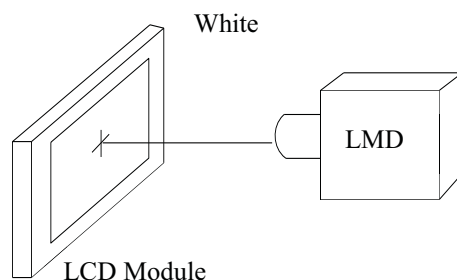

Fig. 6.5 The standard setup of luminance measurement

(5) Definition of uniformity of white screen:

The luminance L_i (i from 1 to 5) is measured at the 5 points defined in Fig. 6.6. H and V indicate active area.

From the measured set of luminance values L_i (i from 1 to 5), the minimum luminance is denoted as L_{\min} and the maximum luminance is denoted as L_{\max} . The uniformity of white screen is defined according to

$$\text{Uniformity} = L_{\min} / L_{\max} \times 100\%$$

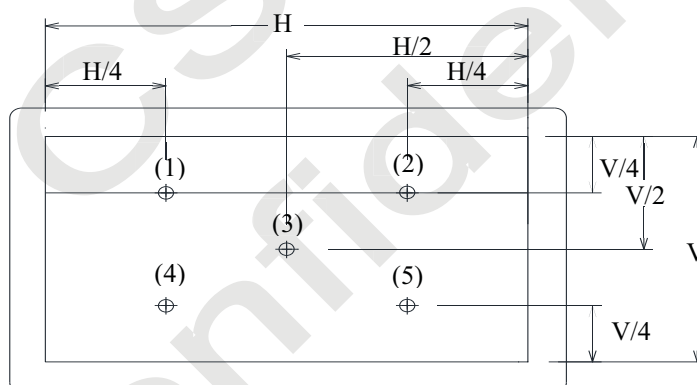

Fig 6.6 Symbol “+” defines the 5 measuring locations (1), (2), (3) … (5)

(6) Definition of color chromaticity:

Each chromaticity coordinates (x, y) are measured in CIE1931 color space when full-screen displaying primary color R, G, B and white. The color gamut is defined as the fraction in percent of the area of the triangle bounded by R, G, B coordinates and the area is defined by NTSC 1953 color standard in the CIE color space. Chromaticity coordinates are measured by CS2000 and the standard setup of measurement is shown in Fig. 6.7.

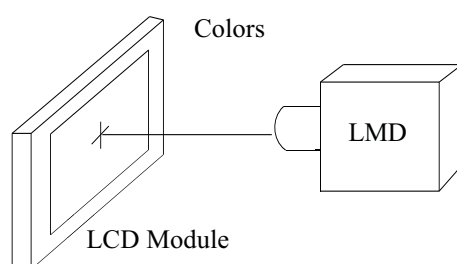

Fig. 6.7 The standard setup of color chromaticity measurement

(7) Definition of viewing angle coordinate system (θ_H , θ_V):

The contrast ratio is measured at the center point of the LCD module. The viewing angles are defined at the angle that the contrast ratio is larger than 10 at four directions relative to the perpendicular direction of the LCD module (two vertical angles: up θ_{V+} and down θ_{V-} ; and two horizontal angles: right θ_{H+} and left θ_{H-}) as illustrated in Fig. 6.8. The contrast ratio is measured by ELDIM EZ Contrast.

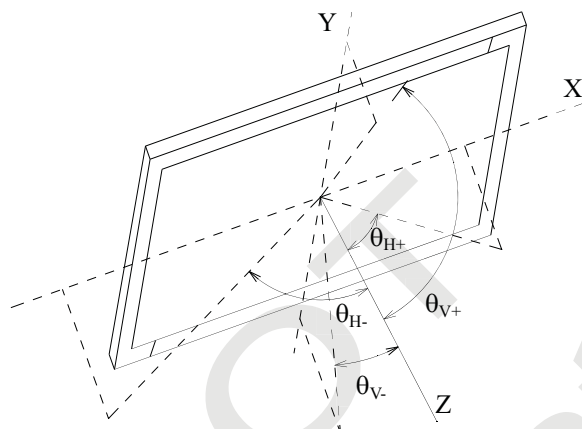
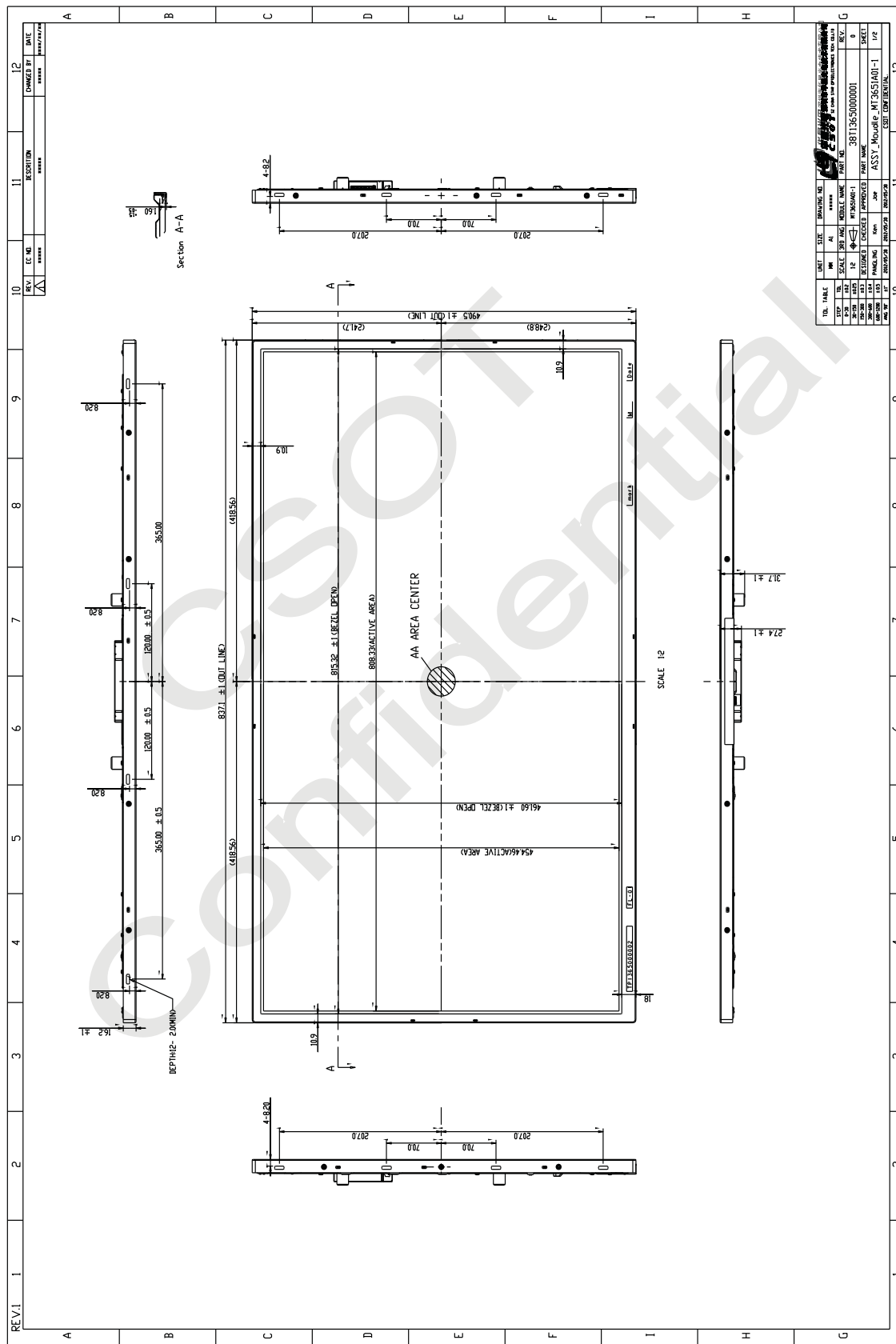

Fig. 6.8 Viewing angle coordination system

7. Mechanical Characteristics

7.1 Mechanical Specification



7.2 Packing

7.2.1 Packing Specifications

Item	Specification		
	Quantity	Dimension (mm)	Weight (kg)
Packing Box	7 pcs / box	960.00 (L) x 387.00 (W) x 605.00 (H)	Net Weight: 40.5 (Max.) Gross Weight: 45 (Max.)
Pallet	1	1200.00 (L) x 1000.00 (W) x 150.00 (H)	Net Weight: 10.5
Stack Layer	1		
Boxes per Pallet	3 boxes / pallet		
Pallet after Packing	21 pcs / pallet	1200.00 (L) x 1000.00 (W) x 760.00(H)	Gross Weight: 147

7.2.2 Packing Method

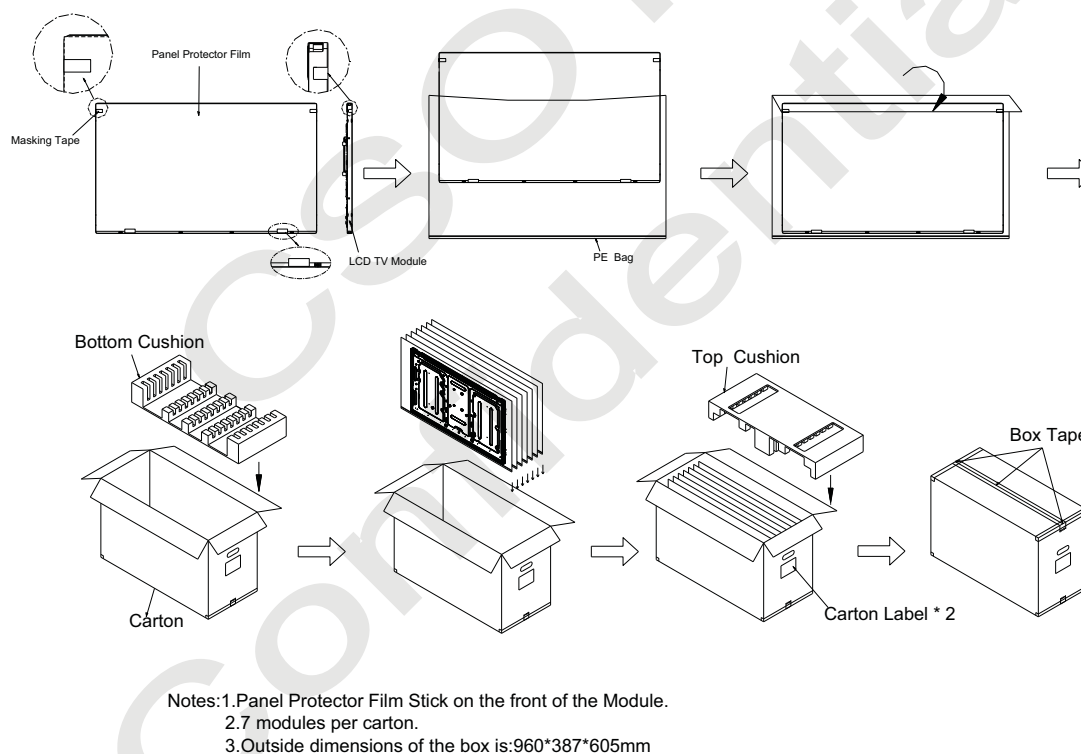
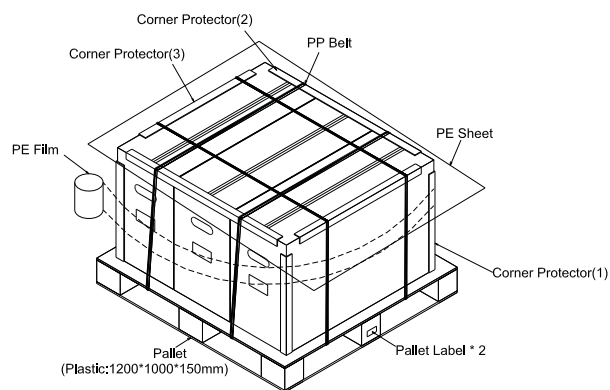
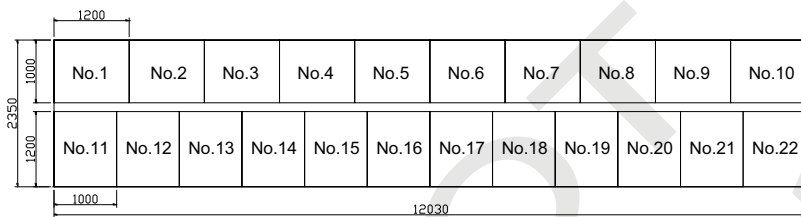

Fig. 7.1 Packing method (protector film stick on the front of the LCD module)



Notes:

1. Corner Protector Dimension And Quantity
 Corner Protector(1):520*50*50, t=3mm, 4pcs
 Corner Protector(2):1060*50*50, t=3mm, 2pcs
 Corner Protector(3):820*50*50, t=3mm, 2pcs
2. Packing Quantity:
 7 Module /Carton
 3 Carton /Pallet
 21 Module /Pallet
 Stack 3 Layers
 22 Pallet /40ft High Container
 1386 Pcs Module /40ft High Container



Pallets in the 40ft Container

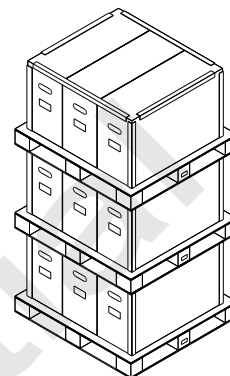
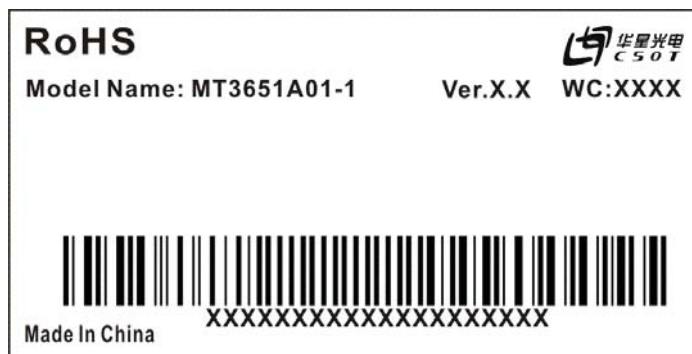

Fig. 7.2 Package

Confidential

8. Definition of Labels

8.1 Module Label



For RoHS compliant products, CSOT will add RoHS for identification.

Model Name: MT3651A01-1

Ver. X.X: Version, for example: 0.1, 0.2, ..., 1.1, 1.2, ..., 2.1, 2.2, ...

WC (Week Code): XX XX

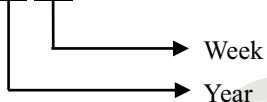

Year: 2010 = 10, 2011 = 11 ... 2020 = 20, 2021 = 21...

Week: 01, 02, 03 ...

Serial Number: XXXXXXXXXXXXXXXX XXXXXXXXXX



8.2 Carton Label

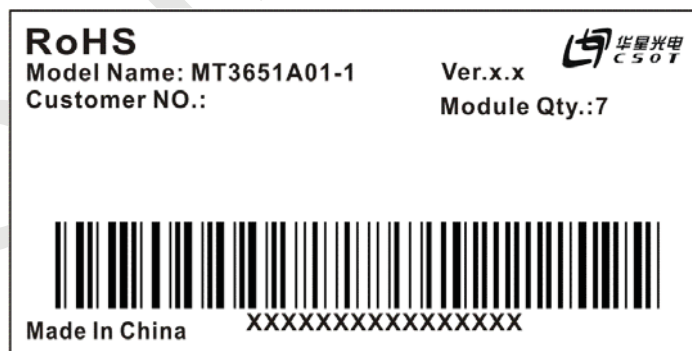

Serial Number: XXXX XX XXXXXX XXXXXX

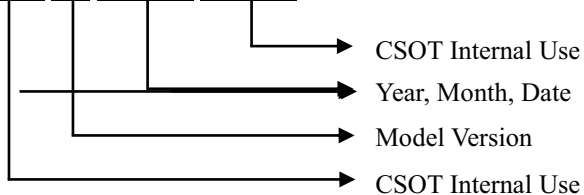

Manufactured Date:

Year: 2010 = 10, 2011 = 11...2020 = 20, 2021 = 21...

Month: 1~9, A~C, for Jan. ~ Dec.

Date: 01~31, for 1st to 31st

Model Version Code: Version of product, for example: 01, 02, 11, 12...

8.3 Pallet Lab



Serial Number: XXX XX XXXXXX XXXXXX

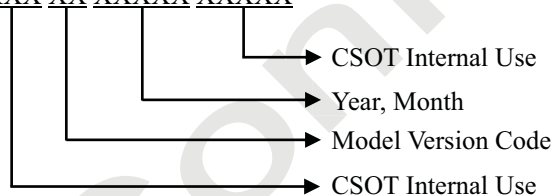

9. Precautions

9.1 Assembly and Handling Precautions

- (1) Do not apply rough force such as bending or twisting to the module during assembly.
- (2) It is recommended to assemble or install a module into the user's system in clean working areas. The dust and oil may cause electrical short or damage the polarizer.
- (3) Do not apply pressure or impulse to the module to prevent the damage to LCD panel and backlight.
- (4) Always follow the correct power-on sequence. This can prevent the damage and latch-up to the LSI chips.
- (5) Do not plug in or pull out the interface connector while the module is in operation.
- (6) Do not disassemble the module.
- (7) Use soft dry cloth without chemicals for cleaning because the surface of polarizer is very soft and easily be scratched.
- (8) Moisture can easily penetrate into the LCD module and may cause the damage during operation.
- (9) High temperature or humidity may deteriorate the performance of the LCD module. Please store LCD modules in the specified storage conditions.
- (10) When ambient temperature is lower than 10 °C, the display quality might be deteriorated. For example, the response time will become slow, and the starting voltage of LED light bar will be higher than that in room temperature.

9.2 Safety Precautions

- (1) If the liquid crystal material leaks from the panel, it should be kept away from the eyes or mouth. In case of contact with hands, skin or clothes, it has to be washed away thoroughly with soap.
- (2) After the module's end of life, it is not harmful in case of normal operation and storage.