

SRAM

16K x 4 SRAM

5 VOLT SRAM

FEATURES

- High speed: 9, 10, 12, 15, 20 and 25ns
- High-performance, low-power, CMOS double-metal process
- Single +5V $\pm 10\%$ power supply
- Easy memory expansion with \overline{CE} option
- All inputs and outputs are TTL-compatible

OPTIONS

- Timing
 - 9ns access
 - 10ns access
 - 12ns access
 - 15ns access
 - 20ns access
 - 25ns access

MARKING

- Packages

Plastic DIP (300 mil)	None
Plastic SOJ (300 mil)	DJ
- 2V data retention L
- Temperature

Commercial (0°C to +70°C)	None
Industrial (-40°C to +85°C)	IT
Automotive (-40°C to +125°C)	AT
Extended (-55°C to +125°C)	XT
- Part Number Example: MT5C6404DJ-15 L

NOTE: Not all combinations of operating temperature, speed, data retention and low power are necessarily available. Please contact the factory for availability of specific part number combinations.

GENERAL DESCRIPTION

The MT5C6404 is organized as a 16,384 x 4 SRAM using a four-transistor memory cell with a high-speed, low-power CMOS process. Micron SRAMs are fabricated using double-layer metal, double-layer polysilicon technology.

For flexibility in high-speed memory applications, Micron offers chip enable (\overline{CE}) with all organizations. This enhancement can place the outputs in High-Z for additional flexibility in system design.

PIN ASSIGNMENT (Top View)

22-Pin DIP (SA-2)

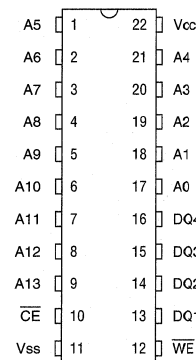

24-Pin SOJ (SD-1)

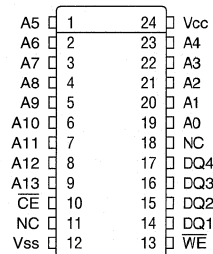

Writing to these devices is accomplished when write enable (\overline{WE}) and \overline{CE} inputs are both LOW. Reading is accomplished when \overline{WE} remains HIGH and \overline{CE} goes to LOW. The device offers a reduced power standby mode when disabled. This allows system designers to meet low standby power requirements.

All devices operate from a single +5V power supply and all inputs and outputs are fully TTL-compatible.

FUNCTIONAL BLOCK DIAGRAM

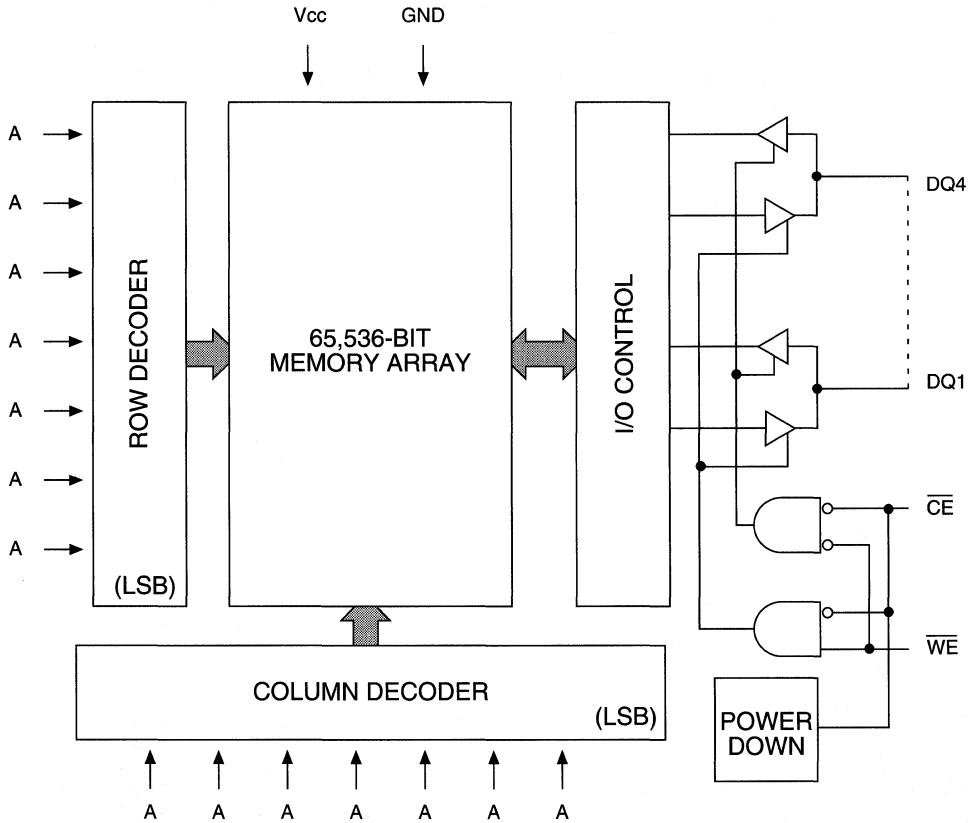

TRUTH TABLE

MODE	CE	WE	DQ	POWER
STANDBY	H	X	HIGH-Z	STANDBY
READ	L	H	Q	ACTIVE
WRITE	L	L	D	ACTIVE

5 VOLT SRAM

ABSOLUTE MAXIMUM RATINGS*

Voltage on Vcc Supply Relative to Vss -1V to +7V
 Storage Temperature (plastic) -55°C to +150°C
 Power Dissipation 1W
 Short Circuit Output Current 50mA
 Voltage on Any Pin Relative to Vss -1V to Vcc +1V

*Stresses greater than those listed under "Absolute Maximum Ratings" may cause permanent damage to the device. This is a stress rating only and functional operation of the device at these or any other conditions above those indicated in the operational sections of this specification is not implied. Exposure to absolute maximum rating conditions for extended periods may affect reliability.

ELECTRICAL CHARACTERISTICS AND RECOMMENDED DC OPERATING CONDITIONS

(0°C ≤ TA ≤ 70°C; Vcc = 5V ±10%)

DESCRIPTION	CONDITIONS	SYMBOL	MIN	MAX	UNITS	NOTES
Input High (Logic 1) Voltage		VIH	2.2	Vcc +1	V	1
Input Low (Logic 0) Voltage		UIL	-0.5	0.8	V	1, 2
Input Leakage Current	0V ≤ VIN ≤ Vcc	ILI	-5	5	μA	
Output Leakage Current	Output(s) disabled 0V ≤ VOUT ≤ Vcc	ILO	-5	5	μA	
Output High Voltage	IOH = -4.0mA	VOH	2.4		V	1
Output Low Voltage	IOL = 8.0mA	VOL		0.4	V	1
Supply Voltage		Vcc	4.5	5.5	V	1

DESCRIPTION	CONDITIONS	SYMBOL	TYP	MAX						UNITS	NOTES
				-9	-10	-12	-15	-20	-25		
Power Supply Current: Operating	$\overline{CE} \leq V_{IL}; V_{CC} = \text{MAX}$ f = MAX = 1/4RC outputs open	Icc	125	190	185	175	165	140	130	mA	3, 13
Power Supply Current: Standby	$\overline{CE} \geq V_{IH}; V_{CC} = \text{MAX}$ f = MAX = 1/4RC outputs open	ISB1	22	60	50	45	40	35	35	mA	13
	$\overline{CE} \geq V_{CC} - 0.2V; V_{CC} = \text{MAX}$ VIN ≤ Vss + 0.2V or VIN ≥ Vcc - 0.2V; f = 0	ISB2	0.5	3	3	3	3	3	5	mA	13

CAPACITANCE

DESCRIPTION	CONDITIONS	SYMBOL	MAX	UNITS	NOTES
Input Capacitance	TA = 25°C; f = 1 MHz Vcc = 5V	CI	5	pF	4
Output Capacitance		Co	7	pF	4

ELECTRICAL CHARACTERISTICS AND RECOMMENDED AC OPERATING CONDITIONS

(Note 5) (0°C ≤ T_A ≤ 70°C; V_{CC} = 5V ±10%)

DESCRIPTION	SYM	-9		-10		-12		-15		-20		-25		UNITS	NOTES
		MIN	MAX	MIN	MAX	MIN	MAX	MIN	MAX	MIN	MAX	MIN	MAX		
READ Cycle															
READ cycle time	^t RC	9		10		12		15		20		25		ns	
Address access time	^t AA		9		10		12		15		20		25	ns	
Chip Enable access time	^t ACE		9		9		10		12		15		20	ns	
Output hold from address change	^t OH	3		3		3		3		3		3		ns	
Chip Enable to output in Low-Z	^t LZCE	2		2		2		2		2		2		ns	7, 14
Chip disable to output in High-Z	^t HZCE		5		5		6		7		8		8	ns	6, 7
Chip Enable to power-up time	^t PU	0		0		0		0		0		0		ns	
Chip disable to power-down time	^t PD		9		10		12		15		20		25	ns	
WRITE Cycle															
WRITE cycle time	^t WC	9		10		12		15		20		25		ns	
Chip Enable to end of write	^t CW	7		8		10		12		15		20		ns	
Address valid to end of write	^t AW	7		8		10		12		15		20		ns	
Address setup time	^t AS	0		0		0		0		0		0		ns	
Address hold from end of write	^t AH	0		0		0		0		0		0		ns	
WRITE pulse width	^t WP1	6		7		8		10		12		15		ns	
WRITE pulse width	^t WP2	8		9		10		14		18		20		ns	
Data setup time	^t DS	5		6		7		8		9		10		ns	
Data hold time	^t DH	1		1		1		1		1		1		ns	
Write disable to output in Low-Z	^t LZWE	2		2		2		2		2		2		ns	7
Write Enable to output in High-Z	^t HZWE		4		5		5		6		8		8	ns	6, 7

INDUSTRIAL TEMPERATURE SPECIFICATIONS (IT)

The following specifications are to be used for Industrial Temperature (IT) MT5C6404 SRAMs.
(-40°C ≤ T_A ≤ 85°C)

DESCRIPTION	CONDITIONS	SYMBOL	MAX					UNITS	NOTES
			-10	-12	-15	-20	-25		
Power Supply Current: Operating	$\overline{CE} \leq V_{IL}; V_{CC} = \text{MAX}$ $f = \text{MAX} = 1/{}^t\text{RC}$ outputs open	I _{CC}	195	185	175	150	140	mA	3, 13
Power Supply Current: Standby	$\overline{CE} \geq V_{IH}; V_{CC} = \text{MAX}$ $f = \text{MAX} = 1/{}^t\text{RC}$ outputs open	I _{SB1}	60	50	45	40	40	mA	13
	$\overline{CE} \geq V_{CC} - 0.2V; V_{CC} = \text{MAX}$ $V_{IN} \leq V_{SS} + 0.2V$ or $V_{IN} \geq V_{CC} - 0.2V; f = 0$	I _{SB2}	5	5	5	5	5	mA	13

DATA RETENTION ELECTRICAL CHARACTERISTICS (L version only)

DESCRIPTION	CONDITIONS	SYMBOL	TYP	MAX	UNITS	NOTES	
Data Retention Current	$\overline{CE} \geq (V_{CC} - 0.2V)$ $V_{IN} \geq (V_{CC} - 0.2V)$ or $\leq 0.2V$	V _{CC} = 2V	I _{CCDR}	130	300	μA	14
		V _{CC} = 3V	I _{CCDR}	210	550	μA	14

ELECTRICAL CHARACTERISTICS AND RECOMMENDED AC OPERATING CONDITIONS

Refer to commercial temperature timing parameters for specifications not listed here.
(Notes 5, 14) (-40°C ≤ T_A ≤ 85°C)

DESCRIPTION	SYM	-12		-15		-20		-25		UNITS	NOTES
		MIN	MAX	MIN	MAX	MIN	MAX	MIN	MAX		
READ Cycle											
Output hold from address change	^t OH	2		2		2		2		ns	
Chip Enable to output in Low-Z	^t LZCE	1		1		1		1		ns	7
WRITE Cycle											
Write disable to output in Low-Z	^t LZWE	1		1		1		1		ns	7

AUTOMOTIVE AND EXTENDED TEMPERATURE SPECIFICATIONS (AT AND XT)

The following specifications are to be used for Automotive Temperature (AT) and Extended Temperature (XT) MT5C6404 SRAMs. (-40°C ≤ T_A ≤ 125°C - AT) (-55°C ≤ T_A ≤ 125°C - XT)

DESCRIPTION	CONDITIONS	SYMBOL	MAX				UNITS	NOTES
			-12	-15	-20	-25		
Power Supply Current: Operating	$\overline{CE} \leq V_{IL}; V_{CC} = \text{MAX}$ $f = \text{MAX} = 1/{}^t\text{RC}$ outputs open	I _{CC}	185	175	150	140	mA	3, 13
Power Supply Current: Standby	$\overline{CE} \geq V_{IH}; V_{CC} = \text{MAX}$ $f = \text{MAX} = 1/{}^t\text{RC}$ outputs open	I _{SB1}	50	45	40	40	mA	13
	$\overline{CE} \geq V_{CC} - 0.2\text{V}; V_{CC} = \text{MAX}$ $V_{IN} \leq V_{SS} + 0.2\text{V}$ or $V_{IN} \geq V_{CC} - 0.2\text{V}; f = 0$	I _{SB2}	5	5	5	5	mA	13

DATA RETENTION ELECTRICAL CHARACTERISTICS (L version only)

DESCRIPTION	CONDITIONS	SYMBOL	TYP	MAX	UNITS	NOTES	
Data Retention Current	$\overline{CE} \geq (V_{CC} - 0.2\text{V})$ $V_{IN} \geq (V_{CC} - 0.2\text{V})$ or $\leq 0.2\text{V}$	V _{CC} = 2V	I _{CCDR}	130	300	μA	14
		V _{CC} = 3V	I _{CCDR}	210	550	μA	14

ELECTRICAL CHARACTERISTICS AND RECOMMENDED AC OPERATING CONDITIONS

Refer to commercial temperature timing parameters for specifications not listed here.

(Notes 5, 14) (-40°C ≤ T_A ≤ 125°C; -55°C ≤ T_A ≤ 125°C; V_{CC} = 5V ±10%)

DESCRIPTION	SYM	-12		-15		-20		-25		UNITS	NOTES
		MIN	MAX	MIN	MAX	MIN	MAX	MIN	MAX		
READ Cycle											
Output hold from address change	^t OH	2		2		2		2		ns	
Chip Enable to output in Low-Z	^t LZCE	1		1		1		1		ns	7
WRITE Cycle											
Write disable to output in Low-Z	^t LZWE	1		1		1		1		ns	7

AC TEST CONDITIONS

Input pulse levels	V _{ss} to 3.0V
Input rise and fall times	3 ns
Input timing reference levels	1.5V
Output reference levels	1.5V
Output load	See Figures 1 and 2

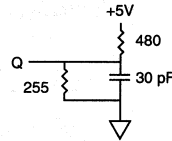

Fig. 1 OUTPUT LOAD EQUIVALENT

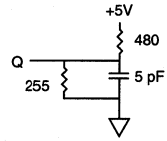

Fig. 2 OUTPUT LOAD EQUIVALENT

NOTES

1. All voltages referenced to V_{ss} (GND).
2. -3V for pulse width < t_{RC}/2.
3. I_{cc} is dependent on output loading and cycle rates.
4. This parameter is sampled.
5. Test conditions as specified with the output loading as shown in Fig. 1 unless otherwise noted.
6. t_{HZCE} and t_{HZWE} are specified with CL = 5pF as in Fig. 2. Transition is measured ±500mV from steady state voltage.
7. At any given temperature and voltage condition, t_{HZCE} is less than t_{LZCE} and t_{HZWE} is less than t_{LZWE}.
8. \overline{WE} is HIGH for READ cycle.
9. Device is continuously selected. All chip enables are held in their active state.
10. Address valid prior to, or coincident with, latest occurring chip enable.
11. t_{RC} = Read Cycle Time.
12. Chip enable and write enable can initiate and terminate a WRITE cycle.
13. Typical values are measured at 5V, 25°C and 15ns cycle time.
14. Typical currents are measured at 25°C.

5 VOLT SRAM

DATA RETENTION ELECTRICAL CHARACTERISTICS (L version only)

DESCRIPTION	CONDITIONS		SYMBOL	MIN	TYP	MAX	UNITS	NOTES
V _{cc} for Retention Data			V _{DR}	2			V	
Data Retention Current	$\overline{CE} \geq (V_{cc} - 0.2V)$ $V_{IN} \geq (V_{cc} - 0.2V)$ or $\leq 0.2V$	V _{cc} = 2V	I _{ccDR}		130	300	μA	14
		V _{cc} = 3V	I _{ccDR}		210	400	μA	14
Chip Deselect to Data Retention Time			t _{CDR}	0			ns	4
Operation Recovery Time			t _R	t _{RC}			ns	4, 11

LOW V_{CC} DATA RETENTION WAVEFORM

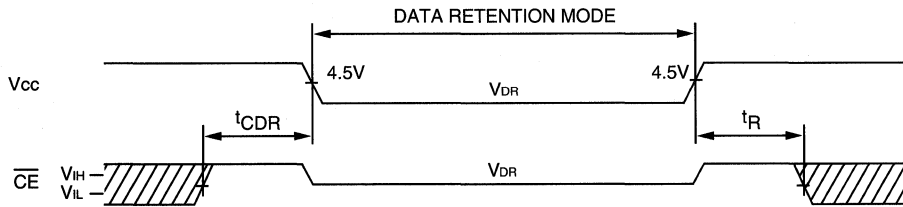

5 VOLT SRAM

READ CYCLE NO. 1^{8,9}

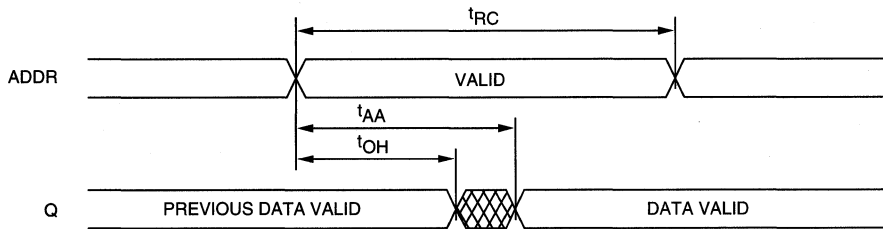

READ CYCLE NO. 2^{7,8,10}

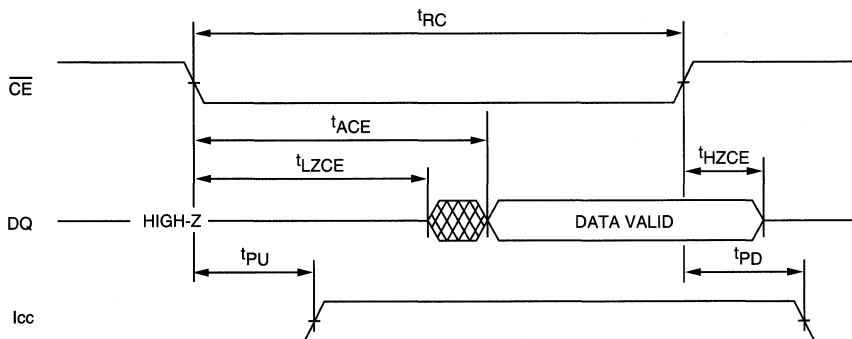

 DON'T CARE
 UNDEFINED

WRITE CYCLE NO. 1
(Chip Enable Controlled)

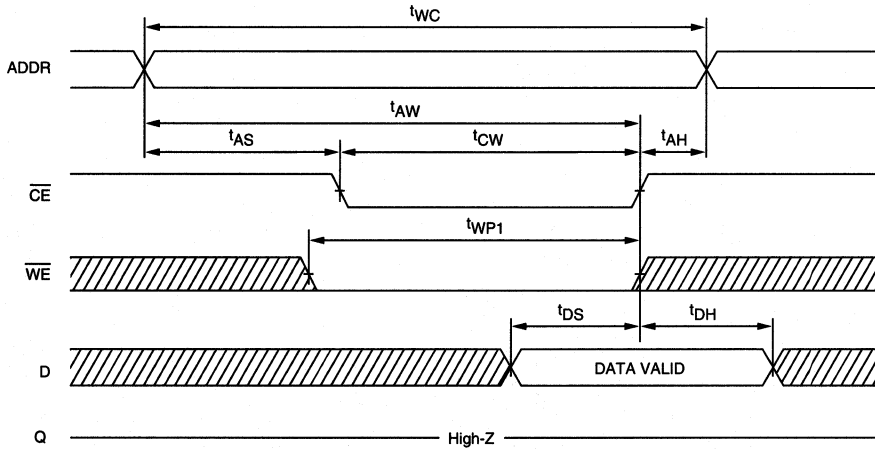

WRITE CYCLE NO. 2^{7, 12}
(Write Enable Controlled)

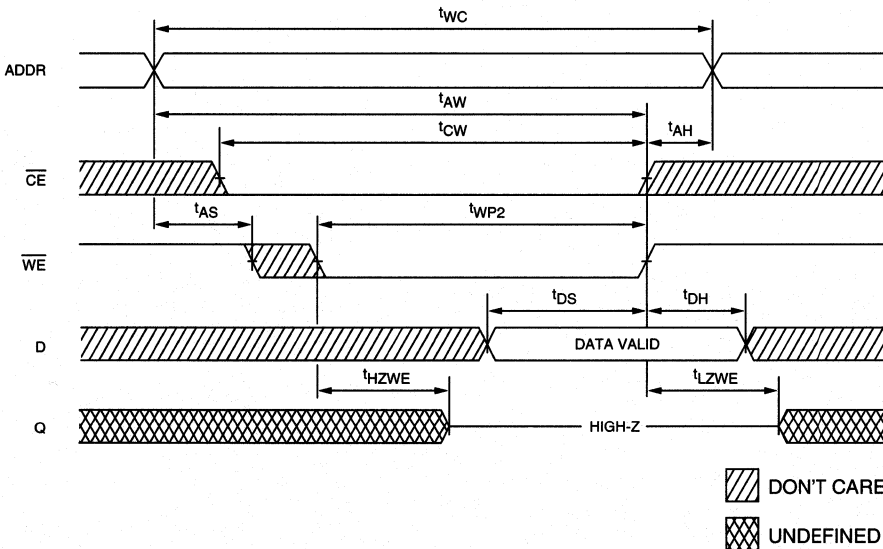

5 VOLT SRAM