

Omni-polar, Low Power AMR Switch IC

1 Product Description

The MT6325 family is produced with monolithic technology. Which built AMR sensor & ASIC on one chip. The IC internally includes a Wheatstone bridge with magnetic film, a voltage regulator for operating with supply voltage from 1.8V to 5.5V, a sleep/awake logic for low power consumption requirement, small signal amplifier and Schmitt trigger comparator with dynamic offset cancellation, and an output driver with push-pull output.

When combined with a magnet, it becomes a non-contact switch with low power consumption, high sensitivity and high reliability. A horizontal magnetic field parallel to the electrode of the package can be detected by an arbitrary polarity.

The MT6325 family provides a variety of packages to customers: SOT-553 for surface mount. All packages are RoHS compliant.

2 Features

- Monolithic Technology
- AMR (Anisotropic Magneto Resistance)
- Omni-polar Switch
- 1.8~5.5V Operating Vcc Range
- -40°C~125°C Operating Temperature
- Package Option:
SOT-553
- Magnetic Sensitivity Option:
BOP=±17Gs, BRP=±14Gs
- Pull-push Output
- Low Power Consumption:
Average Supply Current =4.1uA (Typ)
- RoHS Compliant: (EU)2015/863

3 Product Overview of MT6325

Part No.	Description
MT6325SN	SOT-553, tape & reel (3000pcs/bag)

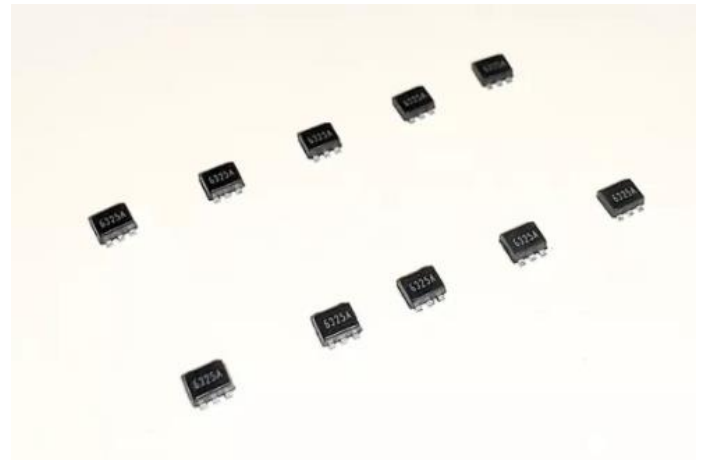

4 Applications

- Industrial
- Position Detection
- Proximity Switch
- Smart Meter
- Speed Detection

5. Pin Configuration and Functions

	Vcc	Out	GND	NC
SOT-553	5	4	2	1、3
Description	Power	Push pull	Ground	

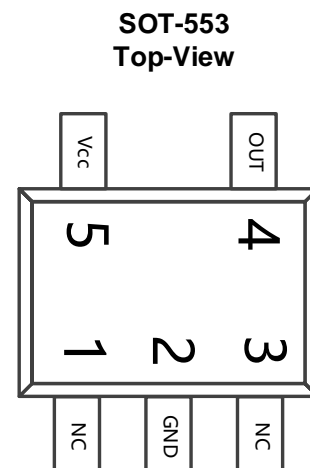

Figure.1 Pin Configuration & Functions

Table of Contents

1	Product Description.....	1
2	Features.....	1
3	Product Overview of MT6325	1
4	Applications.....	1
5	Pin Configuration and Functions.....	1
6	Definition of Switching Function.....	3
7	Function Description.....	3
8	Feature Description.....	3
9	Functional Block Diagram.....	4
10	Electrical and Magnetic Characteristics.....	4
	10.1 Absolute Maximum Ratings.....	4
	10.2 Electrical Specifications.....	5
	10.3 Magnetic Characteristics.....	5
	10.4 ESD Ratings.....	5
	10.5 Characteristic Performance.....	6
	10.6 Typical Output Waveform.....	7
11	Typical Application Circuit.....	7
12	Power on Output Waveform.....	8
13	Package Material Information.....	9
	13.1 SOT-553 Package Information.....	9
14	Copy Rights and Disclaimer.....	10

Reversion History

1	4.1Version	Update format Remove MT6325ET
---	------------	----------------------------------

6 Definition of Switching Function

Figure.2 shows the device functionality and hysteresis

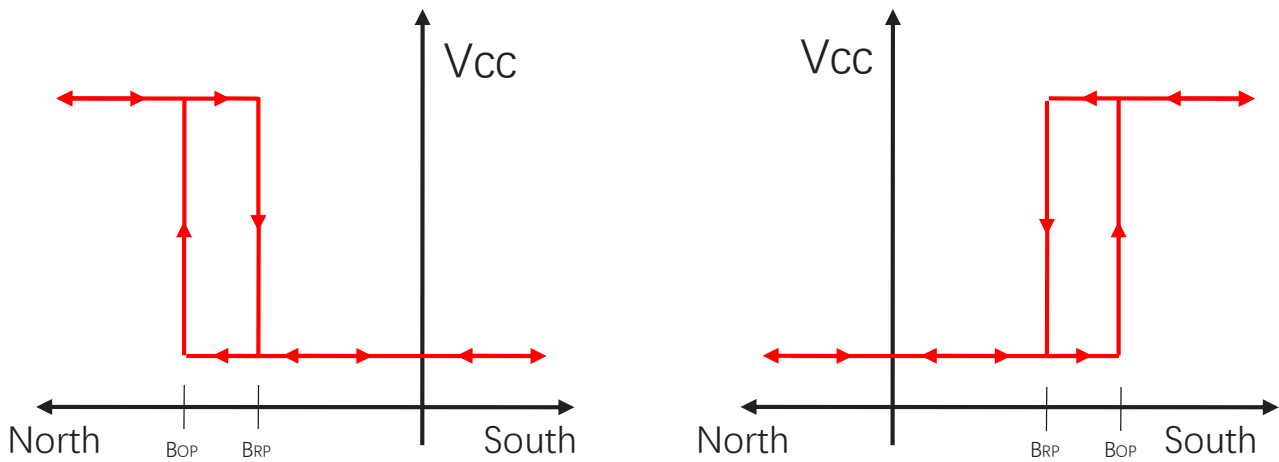

Figure.2 Omni-polar Switching Function

7 Function Description

B_{OP}: Operating Point, Magnetic flux density applied on the branded side of the package which turns the output driver ON ($V_{OUT}=High$)

B_{RP}: Releasing Point, Magnetic flux density applied on the branded side of the package which turns the output driver OFF ($V_{OUT}=Low$)

B_{HYST}: Hysteresis Window, $|B_{OP} - B_{RP}|$

8 Feature Description

The MT6325 device is sensitive to the magnetic field that is parallel to the package

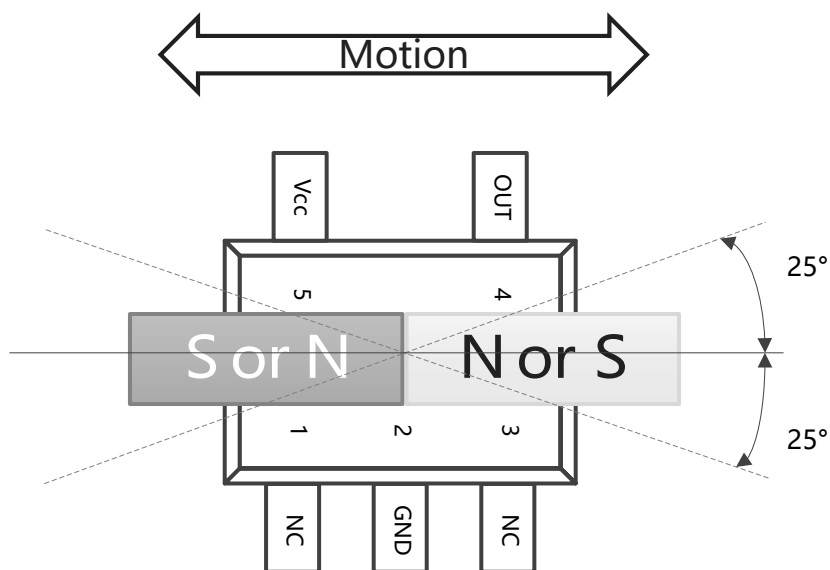

Figure.3 Flux Direction Polarity

9 Functional Block Diagram

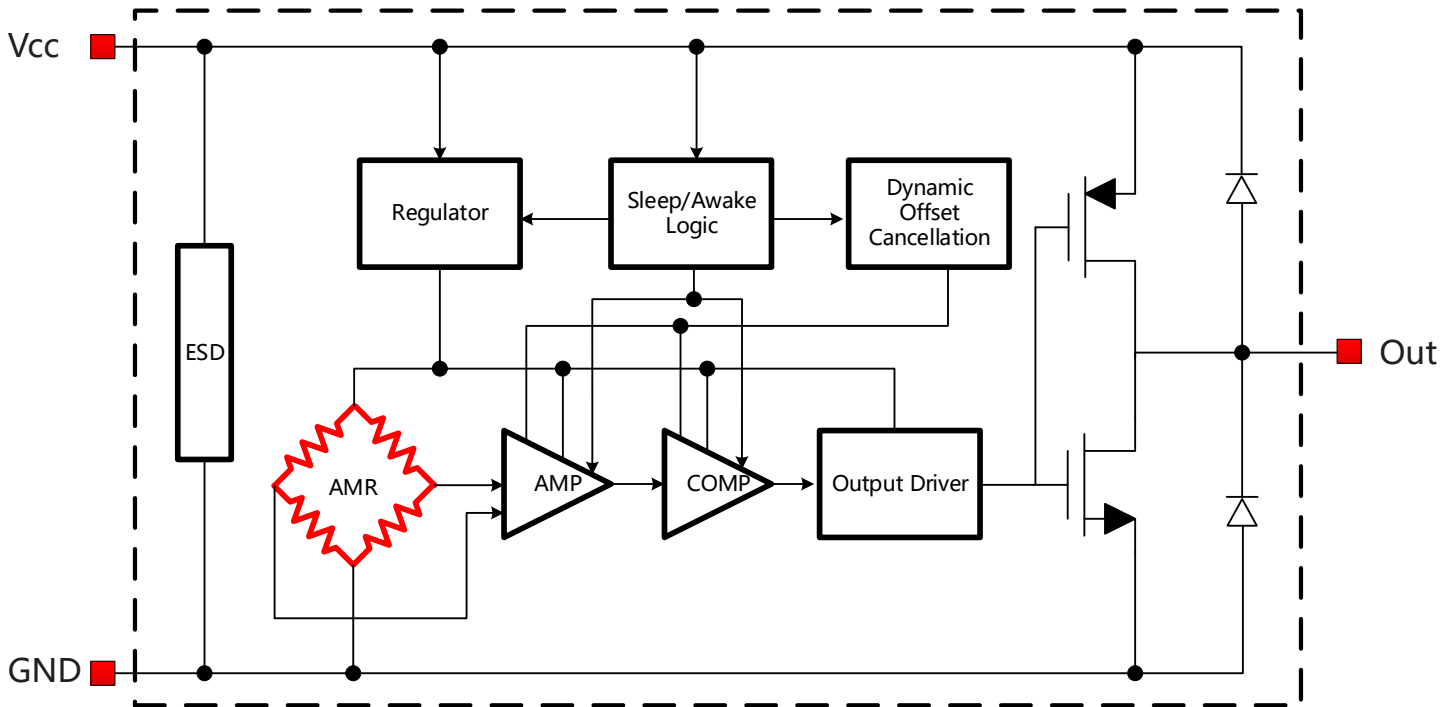

Figure.4 Functional Block Diagram

10 Electrical and Magnetic Characteristics

10.1 Absolute Maximum Ratings

Absolute maximum ratings are limited values to be applied individually, and beyond which the serviceability of the circuit may be impaired. Functional operability is not necessarily implied. Exposure to absolute maximum rating conditions for an extended period of time may affect device reliability.

Symbol	Parameters	Min	Max	Units
V _{CC}	Supply Voltage	-	7	V
V _{RCC}	Reverse Battery Voltage	-0.5	-	V
V _{OUT}	Output Voltage	-0.5	7	V
I _{OUT}	Continuous Output Current	-	10	mA
T _A	Operating Ambient Temperature	-40	125	°C
T _S	Storage Temperature	-50	150	°C
T _J	Junction Temperature	-	165	°C
B	Magnetic Flux Density		3000	Gs

10.2 Electrical Specifications

At $T_A = -40 \sim 125^\circ\text{C}$, $V_{CC} = 1.8\text{V} \sim 5.5\text{V}$ (unless otherwise specified)

Symbol	Parameters	Test Condition	Min	Typ	Max	Unit
V_{CC}	Supply Voltage	Operating	1.8	-	5.5	V
I_{CC}	Supply Current	$V_{CC} = 3.6\text{V}$	-	4.1	7.0	μA
V_{OL}	Output Low Voltage	$V_{CC} = 3.6\text{V}$, $I_{OUT} = 5\text{mA}$, $ B < B_{RP} $	-	-	0.2	V
V_{OH}	Output High Voltage	$V_{CC} = 3.6\text{V}$, $I_{OUT} = 5\text{mA}$, $ B > B_{OP} $	$V_{CC} - 0.3$	-	-	V
I_{OFF}	Output Leakage Current	$V_{OUT} = 5.5\text{V}$, $ B < B_{RP} $	-	-	1	μA
T_{PO}	Power on Time	$dV_{CC}/dt > 3.6\text{V}/\mu\text{s}$, $B > B_{OP}(\text{MAX})$	-	-	100	μs
F_{SW}	Switching Frequency	$V_{CC} = 3.6\text{V}$	-	900	-	Hz
T_{AW}	Awake Time	$V_{CC} = 3.6\text{V}$	-	12	-	μs
T_{SL}	Sleep Time	$V_{CC} = 3.6\text{V}$	-	1.11	-	ms
D.C.	Duty Cycle	$V_{CC} = 3.6\text{V}$	-	1.1	-	%
R_{TH}	Thermal Resistance of SOT-553		-	301	-	$^\circ\text{C}/\text{W}$

10.3 Magnetic Characteristics

At $V_{CC} = 1.8\text{V} \sim 5.5\text{V}$ (unless otherwise specified)

Part No.	Symbol	Min	Typ	Max	Unit
MT6325 Series	B_{OP} , $T_A = 25^\circ\text{C}$	± 7	± 17	± 27	Gs
	B_{RP} , $T_A = 25^\circ\text{C}$	± 4	± 14	± 24	Gs
	B_{HYST} , $T_A = 25^\circ\text{C}$	1	3	6	Gs

10.4 ESD Ratings

Symbol	Reference	Values	Unit	
V_{ESD}	Human-body model (HBM)	AEC-Q100-002	± 5000	V
	Charged-device model (CDM)	AEC-Q100-011	± 1000	V

10.5 Characteristic Performance

At $V_{CC}=3.6V$, $B < B_{RPMIN}$

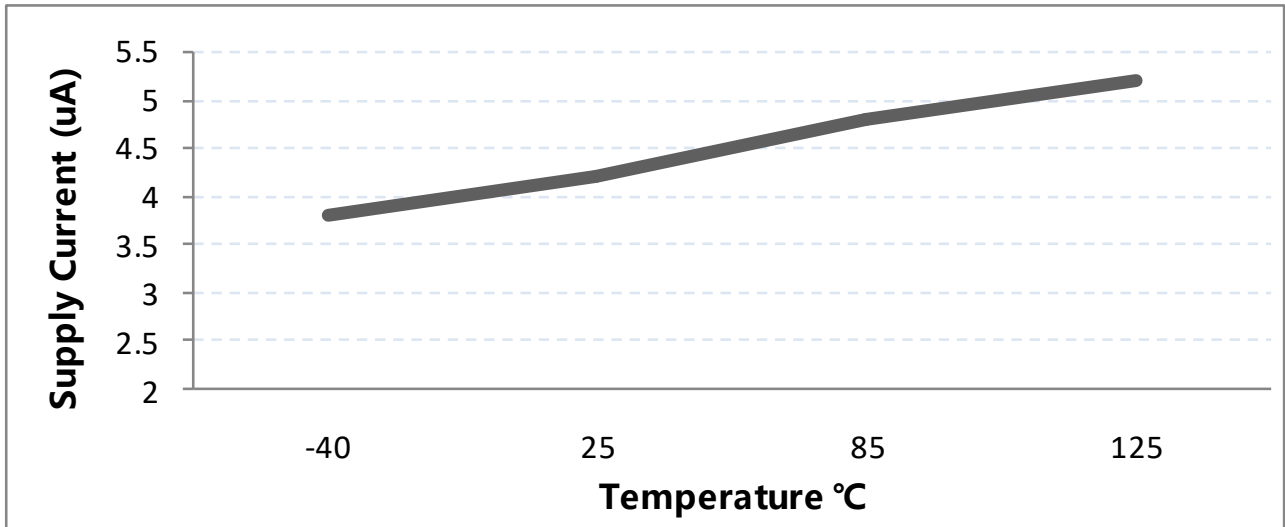

Figure.5 Supply Current vs. Temperature

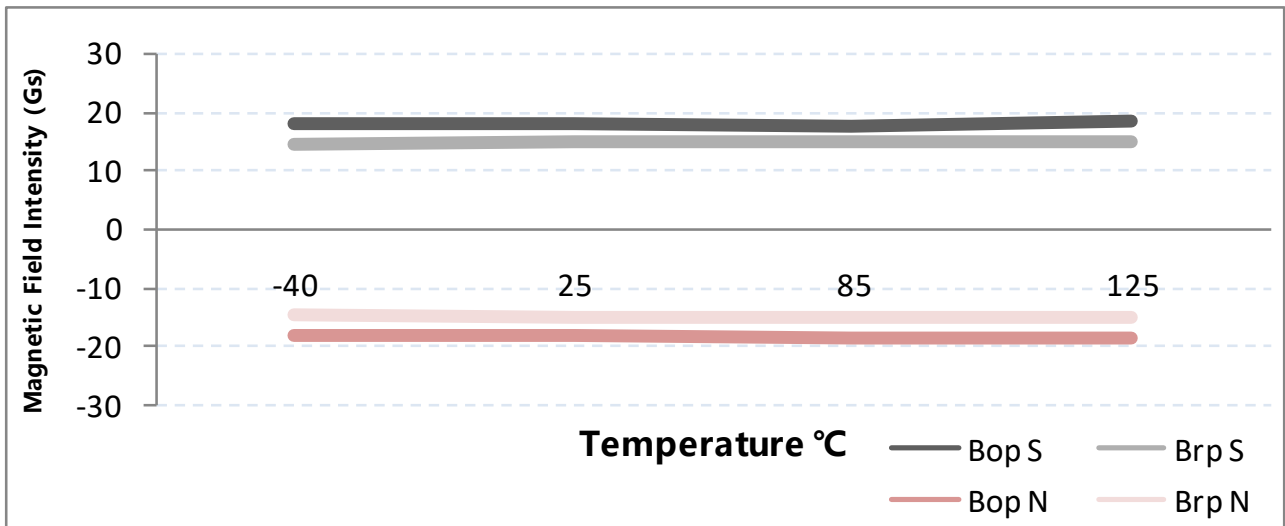

Figure.6 Magnetic Characteristics vs. Temperature (BOP & BRP)

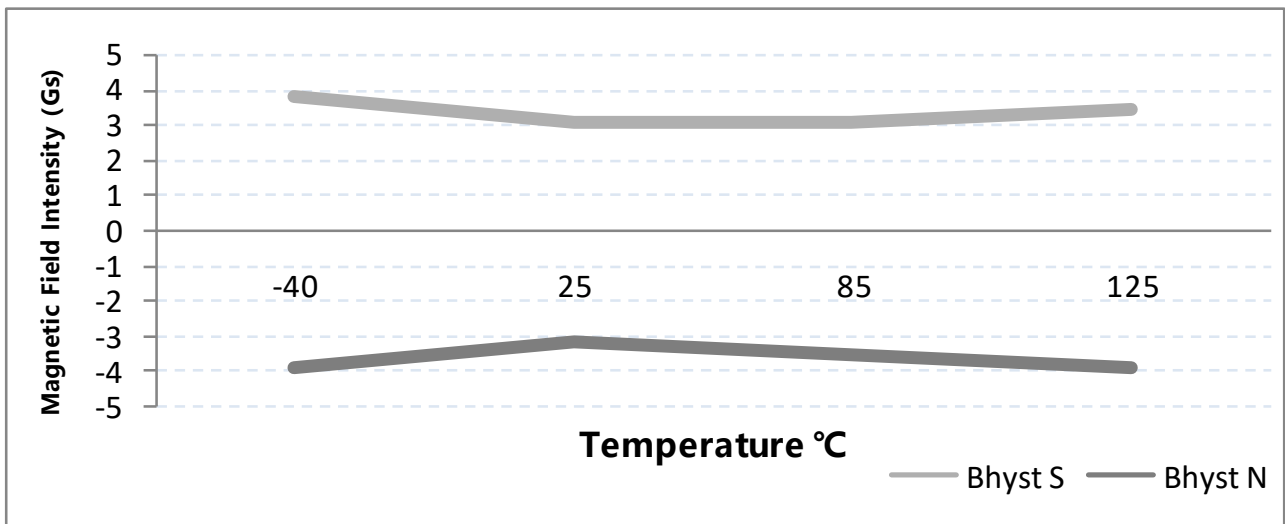

Figure.7 Magnetic Characteristics vs. Temperature (BHYST)

10.6 Typical Output Waveform

MT6325SN as example

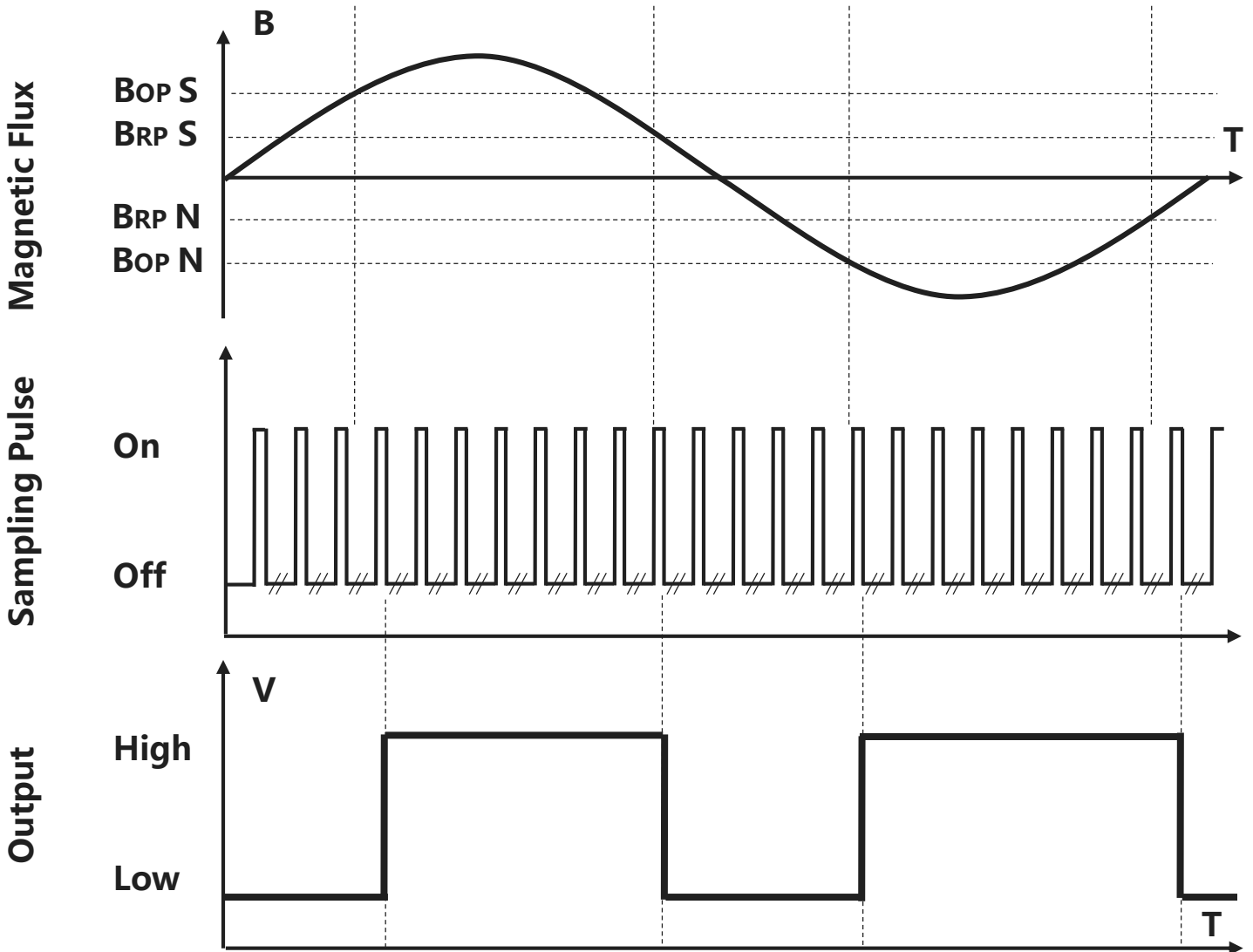

Figure.8 Digital Output vs. Magnetic Flux Density & Sampling Pulse

11 Typical Application Circuit

MT6325SN as example

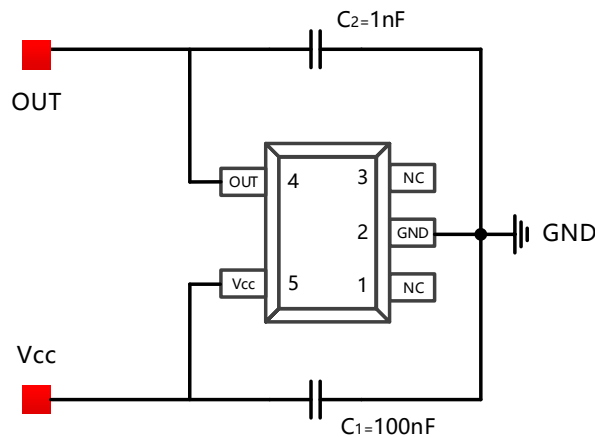

Figure.9 Typical Application Circuit

12 Power on Output Waveform

V_{CC} rise time $< 1\mu s$, T_{PO} is the time from the stable point of V_{CC} to the valid point of output

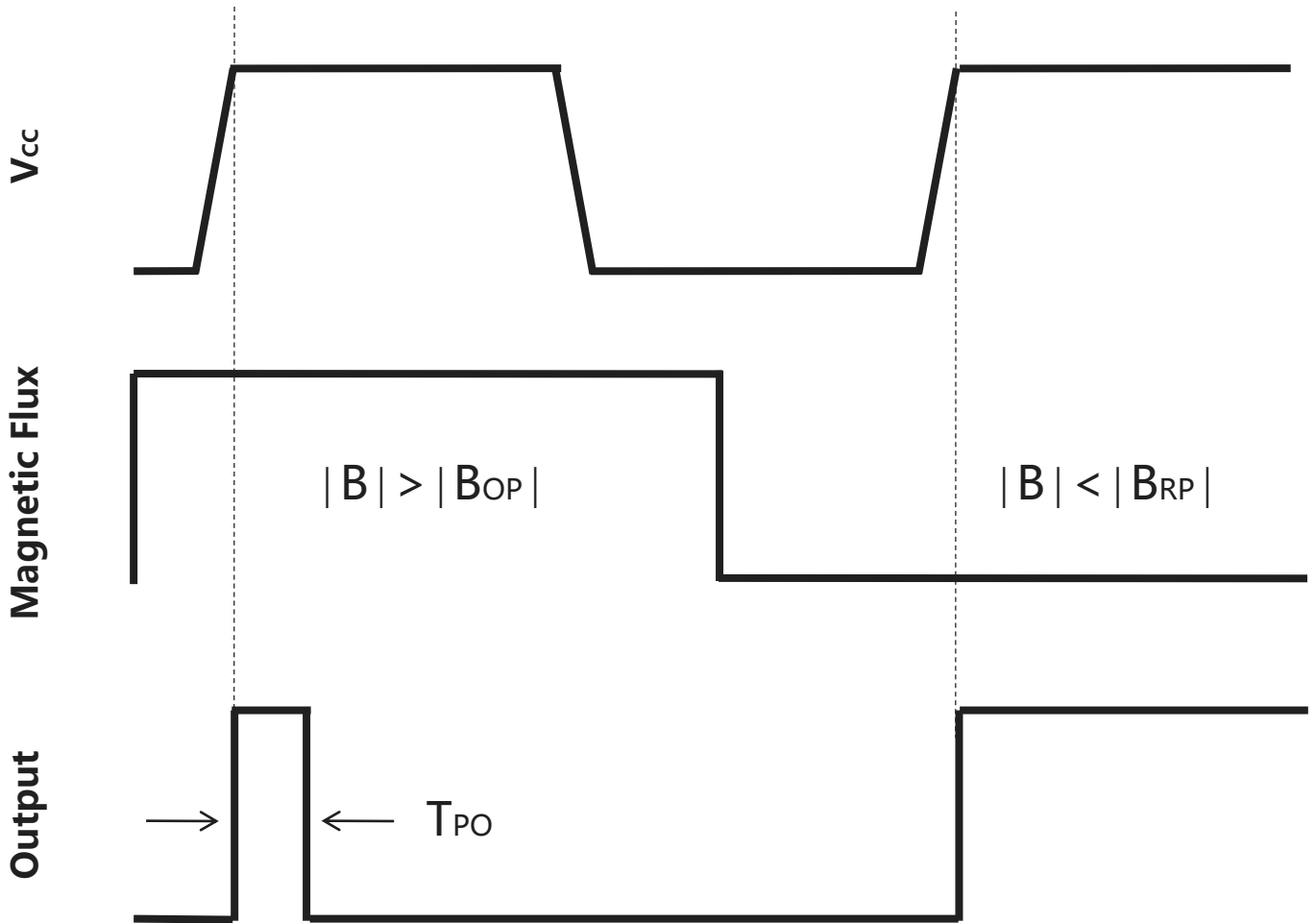

Figure.10 Power on Output Waveform

13 Package Material Information (For Reference Only – Not for Tooling Use)

13.1 SOT-553 Package Information

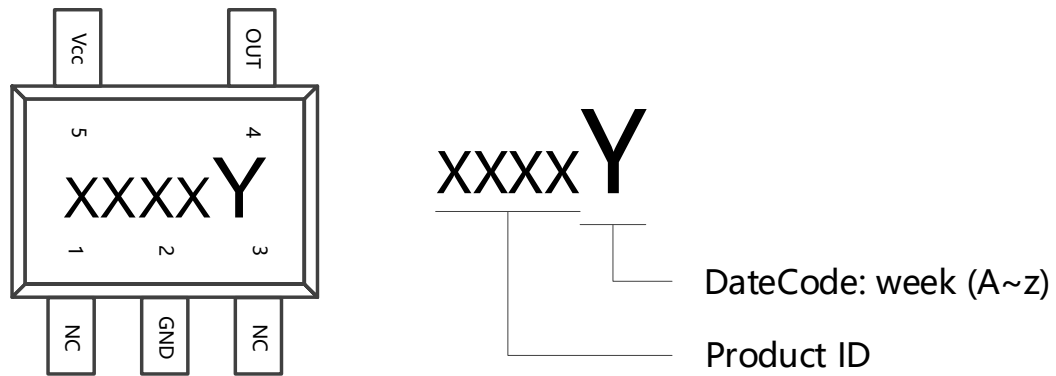

Figure.11 SOT-553 Chip Marking Spec

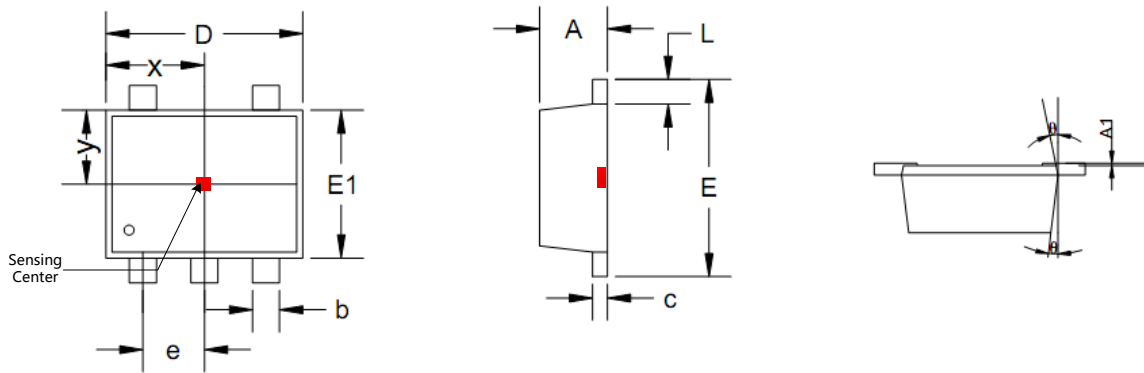

Figure.12 SOT-553 Package Drawing

Symbol	Dimensions in Millimeters		Dimensions in Inches	
	Min	Max	Min	Max
A	0.525	0.600	0.021	0.024
A1	0.000	0.050	0.000	0.002
e	0.450	0.550	0.018	0.022
c	0.090	0.160	0.004	0.006
D	1.500	1.700	0.059	0.067
b	0.170	0.270	0.007	0.011
E1	1.100	1.300	0.043	0.051
E	1.500	1.700	0.059	0.067
L	0.100	0.300	0.004	0.012
θ	7 ° REF		7 ° REF	
x	0.800 TYP		0.032 TYP	
y	0.600 TYP		0.024 TYP	

14 Copy Rights and Disclaimer

1. This document may not be reproduced or duplicated, in any form, in whole or in part without prior written consent of MagnTek . Copyrights © 2019, MagnTek Incorporated.
2. MagnTek reserves the right to make changes to the information published in this document at anytime without notice.
3. MagnTek' s products are limited for use in normal commercial applications. MagnTek' s products are not to be used in any device or system, including but not limited to medical life support equipment and system.

For the latest version of this document, please visit our website: www.magntek.com.cn