

DESCRIPTION

The MT7261 is a Boost constant current white LED driver designed for wide input voltage range from 2.5V to 30V system rail, drives up to 7X1W power with AC12V/DC12V input voltage. Current mode and fixed frequency operation provides fast transient response and eases loop stabilization. With a current sense amplifier threshold of 205mV, the LED current is programmable with one external current sense resistor and the power loss is minimized. The 550KHz operating frequency minimizes external inductor, input and output capacitor. The MT7261 supports both PWM and analog dimming by a single control pin. Fault condition protection includes over voltage protection(OVP), cycle-by-cycle peak current limiting and thermal shutdown. The MT7261 is available in SOP8 packages.

FEATURES

- 2.5V to 30V input/output voltage range
- High efficiency up to 95%
- Cycle by Cycle Over Current Protection
- Internal 0.2ohm power MOSFET
- LED temperature protection
- Stable with Low ESR Ceramic Capacitor
- OTP and OVP protection
- External setting over voltage protection
- Fixed switching frequency: 550KHz
- Low feedback voltage: 205mV
- Adjustable soft-start
- Support one pin analog dimming and up to 50Khz PWM dimming
- Available in SOP8 package

APPLICATION

- Automotive and Marine Lighting
- High Power LED Driver
- Torch Driver
- Low Voltage LED Lighting (Landscape, Desk, Room, MR16 lighting)
- LED backlighting

TYPICAL APPLICATION (STEP-UP/BOOST APPLICATION)

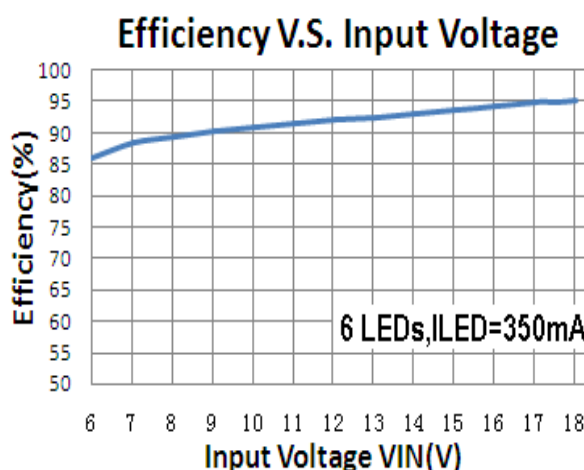
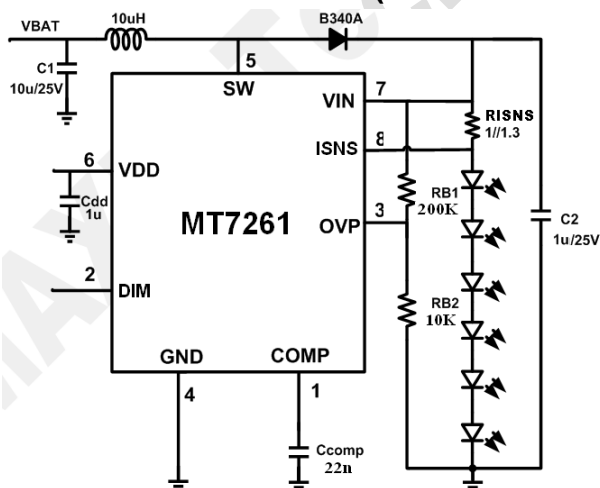

ORDERING INFORMATION

Device Mark	Package Type	Reel size(mm)	Reel width(mm)	Quantity per reel
MT7261	SOP8			2500

PIN CONFIGURATIONS

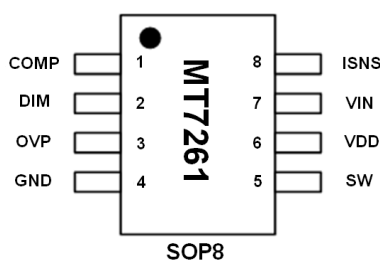

Pin description

Name	Pin No.	Description
COMP	1	Compensation Pin. Connect a 22nF ceramic capacitor (C_{COMP}) from COMP to GND. This capacitor stabilizes the loop, controls soft-start time.
DIM	2	Brightness and On/Off Control Pin. A voltage greater than 0.4V will turn on the chip. When DIM pin voltage varying from 0.4V to 1.6V, the LED current will change from 0% to 100% of the maximum current. Any voltage above 1.6V will clamp to 100% maximum current. To use PWM dimming, apply a 1KHz to 50KHz square wave signal with amplitude greater than 1.6 V to this pin. Hold DIM below 200mV for 2mS to shut down the IC .
OVP	3	Over voltage protection Pin. OVP happening turns off the chip after OVP pin voltage higher than 1.2V, OVP comparator has internal 100mV hysteresis.
GND	4	Ground
SW	5	Switch Output. SW is the source of the internal MOSFET switch. Connect to the power inductor and cathode of the Schottky rectifier. Keep the traces to the switching components as short as possible to minimize radiation and voltage spikes.
VDD	6	5V Reference Output. Bypass VDD to GND with a 1 μ F or greater ceramic capacitor.
VIN	7	Supply voltage. Bypass VIN to GND with 1u ceramic capacitor. MT7261 operates from a 2.5V to 30V unregulated input.
ISNS	8	LED current sense pin, the voltage between VIN and ISNS is 205mV.



Maximizing IC Performance

MT7261

Boost White LED Driver

With High Frequency PWM Dimming

ABSOLUTE MAXIMUM RATINGS

SW/VIN/ISNS/OVP pin	-0.3V to +38V
All other pins	+0.3V to 6V
Storage Temperature	-55°C to 150°C
Junction to ambient (RθJA)	120°C/W

RECOMMENDED OPERATING CONDITIONS

Supply voltage	2.5V to 30V
Output Voltage	Vin to 30V
Operating Temperature	-40°C to 105°C
Maximum Driving LEDs in series	7 LEDs in series

ELECTRICAL CHARACTERISTICS

(Test conditions: V_{BAT}=5V, T_A=25°C unless otherwise stated.)

Symbol	Parameter	Conditions	Min	Typ	Max	Unit
V _{BAT}	Input (Battery) Voltage		2.5		30	V
I _{shutdown}	Supply current (Shutdown)	V _{DIM} =0V		40		μA
I _Q	Supply current (No Switching)	V _{comp} =0V		300		μA
f _{SW}	Switching frequency			550		KHz
D _{max}	Maximum duty cycle	V _{IN} -V _{ISNS} =0.1V	85	95		%
Over Voltage lockout (OVP)						
OV	Over voltage protection reference			1.2		V
	OV reference hysteresis			100		mV
Enable/Dimming (DIM)						
V _{EN}	Enable Threshold	DIM rising		0.4		V
V _{EN_HYS}	DIM Hysteresis			0.2		mV
	DIM Pin pull up current	DIM=0V		1		uA
	Analog dimming voltage range		0.4		1.6	V
	PWM dimming frequency	<i>Note 1</i>	1		50	KHz
	DIM shutdown delay	DIM pin keep low		2		mS
Current Sense (ISNS)						
V _{IN} -V _{ISNS}	Current sense voltage			205		mV
Output Switch (SW)						
R _{on}	SW On-resistance	<i>Note 1</i>		0.2		Ω
I _{lim}	Current limit	<i>Note 1</i>		3		A
OTP	Thermal protection threshold			160		°C
	OTP hysteresis			30		°C

Note 1: Guaranteed by design

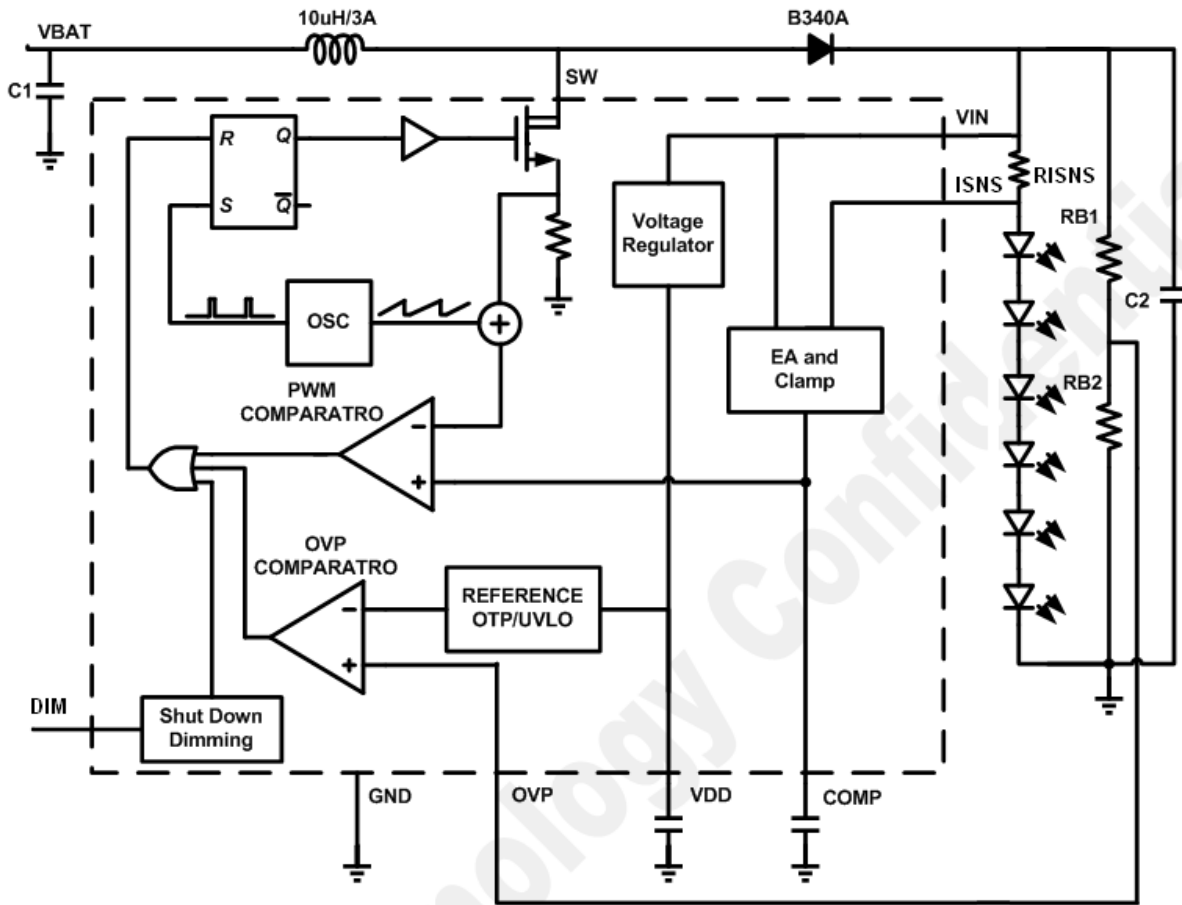
BLOCK DIAGRAM

Figure 1—Function Block Diagram

TYPICAL OPERATING CHARACTERISTICS

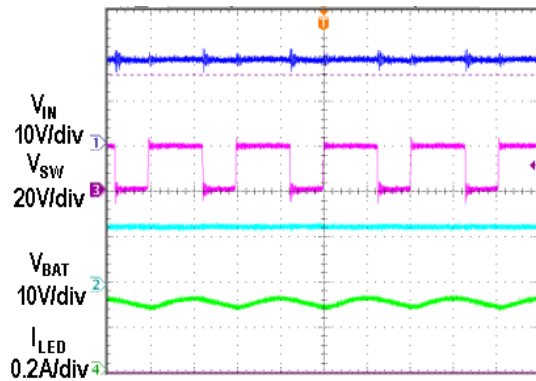
($V_{BAT} = 12V$, 6 LEDs, I_{out} set as 350mA, unless otherwise noted.)

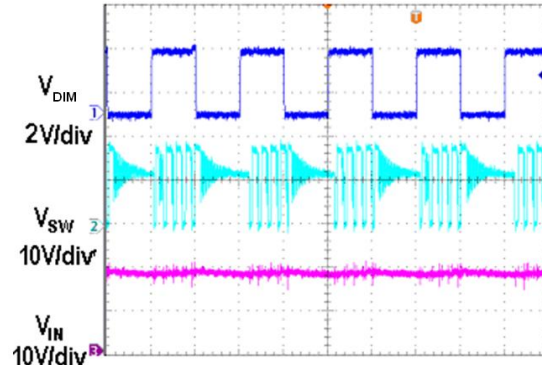
Steady State Operation

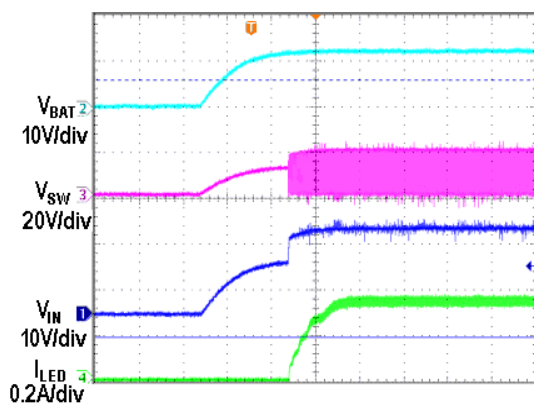
 1 μ S/div

Direct PWM Dimming($f=50KHz$)

 10 μ S/div

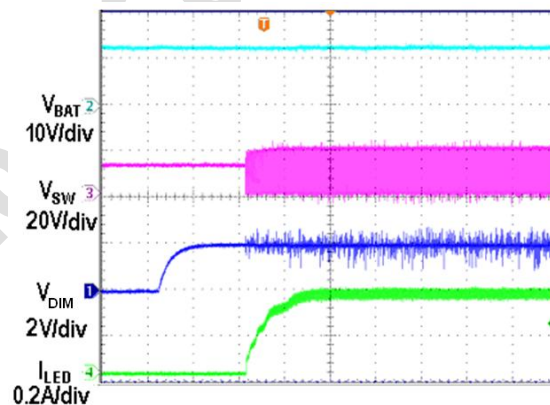
Start up with VBAT

4mS/div

Start up with DIM

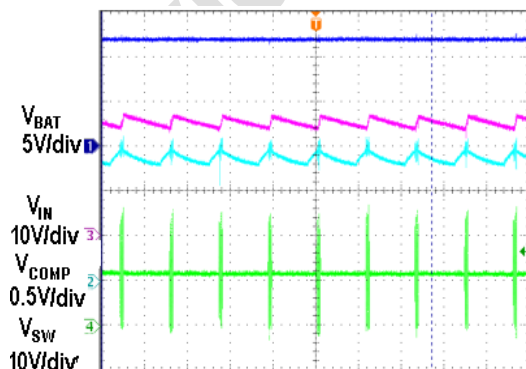
4mS/div

Open LED Protection

4mS/div

TYPICAL OPERATING CHARACTERISTICS (CONTINUED)

($V_{BAT} = 12V$, 6 LEDs, I_{out} set as 350mA, unless otherwise noted.)

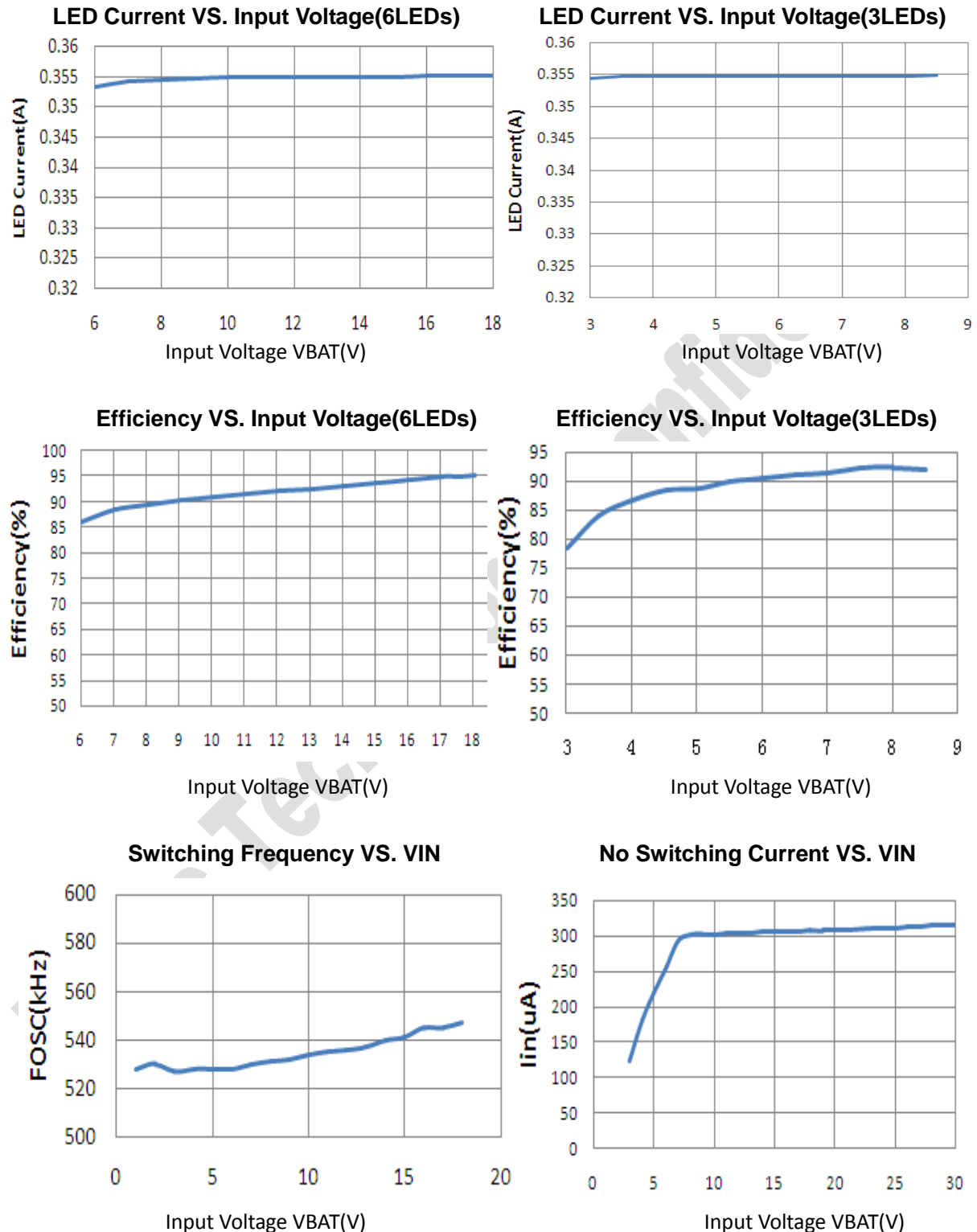

TYPICAL OPERATING CHARACTERISTICS (CONTINUED)

($V_{BAT} = 12V$, 6 LEDs, I_{out} set as 350mA, unless otherwise noted.)

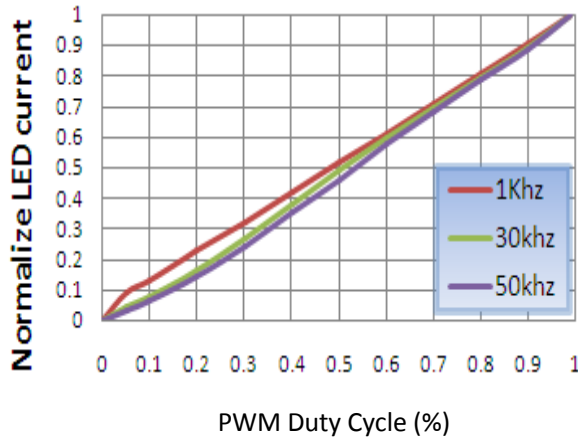
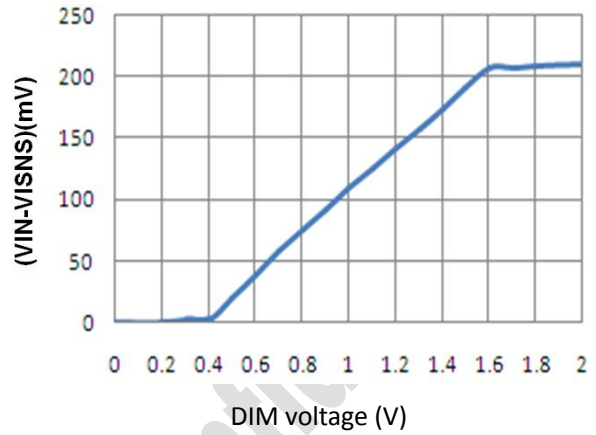
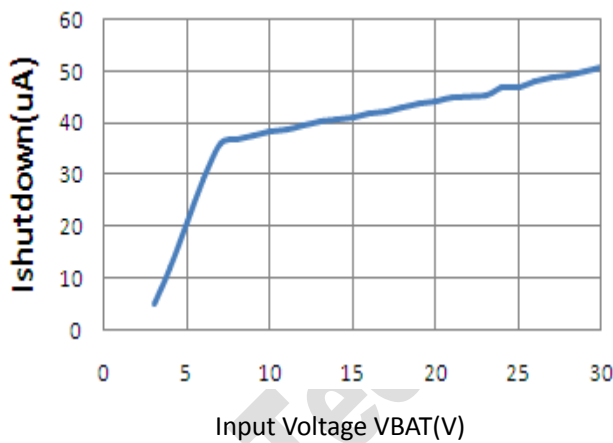
Normalized LED Current VS. PWM Duty Cycle

(VIN-VISNS) Voltage VS. DIM Voltage

Shutdown Current VS. VIN

TYPICAL APPLICATION CIRCUITS

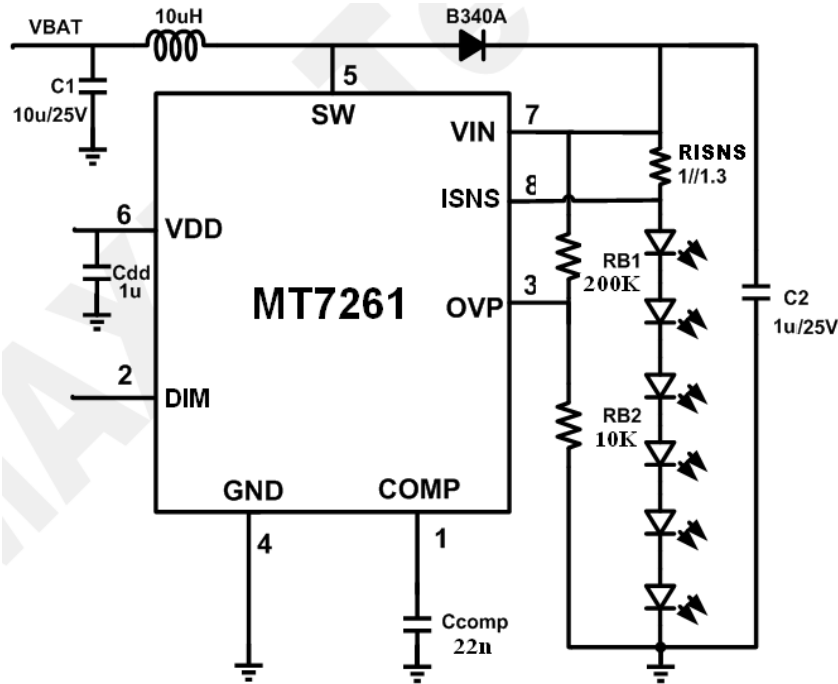

Figure 2— Typical BOOST application for LED Driver

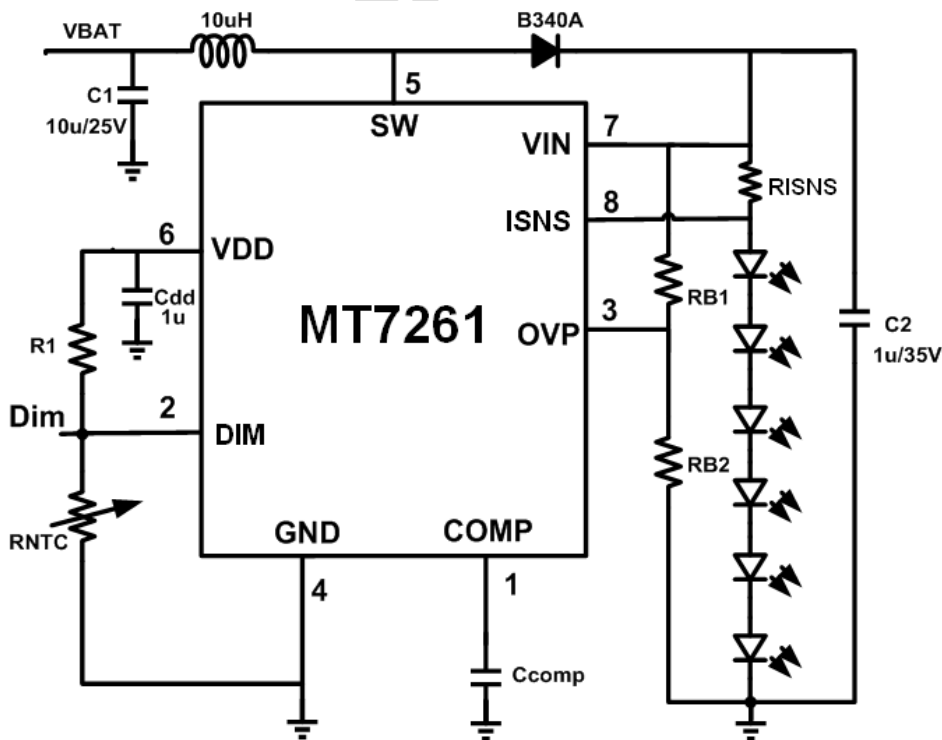

Figure 3— BOOST LED Driver with NTC resistor to protect LED

TYPICAL APPLICATION INFORMATION

Soft-Start

The MT7261 attains soft-start by charging C_{COMP} gradually with a current source (8uA). When V_{COMP} rises above 1.3V, the internal MOSFET begins switching with an incremental duty cycle. Use 22nF ceramic capacitor is enough for stabilizing the loop and the soft start function.

Shutdown

The MT7261 enters shutdown mode when V_{DIM} is less than 200mV for more than 2ms. In shutdown mode, supply current is reduced to 40uA by powering down the entire IC except the DIM voltage-detection circuitry. C_{COMP} is discharged to zero during shutdown period, allowing the device to re-initiate a soft-start procedure when the chip is enabled.

Over-Voltage Protection

Over Voltage Protection (OVP) occurs when the LED is open. The LED open will breakdown the chip if there is no OVP protection circuitry. (Refer to waveform of Open LED protection in TYPICAL OPERATING CHARACTERISTICS Section). The over voltage protection threshold can be set according to actual number of LEDs by the external resistor ratio. The OVP comparator reference is 1.2V with 100mV hysteresis.

In normal operation, MT7261 over voltage protection threshold voltage calculates as:

$$V_{IN} = 205mV + V_{LED} \times K < V_{OVP} = 1.2 \times (1 + RB1/RB2)$$

Where

K -- Number of LEDs in each string

V_{LED} -- one LED forward voltage

The recommended OVP point is about 1.2 times higher than the normal output voltage.

Setting the LED Current

The LED current is programmed by the external current sense resistor RISNS through the following equation

$$I_{LED} = \frac{205}{RISNS(ohm)} (mA)$$

Analog and PWM Dimming

The MT7261 allows both DC and PWM dimming. When V_{DIM} is less than 0.2V, the chip is turned off. For analog dimming, when V_{DIM} rises from 0.4V to 1.6V, the LED current will change from 0% to 100% of the maximum LED current. If V_{DIM} is higher than 1.6V, maximum LED current is generated. If a PWM signal is used, its amplitude V_{DIM} must exceed 1.6V. Apply a 1KHz to 50KHz PWM signal to DIM pin, the LED current will change from 0% to 100% according to the duty cycle. (Refer to LED Current VS. PWM Duty Cycle in TYPICAL OPERATING CHARACTERISTICS Section)

Capacitor Selection

The typical value for the input capacitor is 10uF and the typical value for the output capacitor is 1uF. Larger value capacitors can be used to further reduce input and output ripple. Keep the capacitor impedance low at switching frequency is important, ceramic capacitors with X5R or X7R dielectrics are highly recommended. C_{COMP} stabilizes the loop and controls soft-start time. Connect a 22nF capacitor from COMP pin to GND.

Inductor Selection

Inductor value ranges from 10uH to 47uH. A

Maximizing IC Performance

10 μ H inductor optimizes the efficiency for most applications. To prevent core saturation, ensure that the inductor-saturation current rating exceeds about 30%-40% of the peak inductor current for the application.

Schottky Diode Selection

The MT7261's high switching frequency demands a high-speed rectification diode for optimum efficiency. A Schottky diode is recommended due to its fast recovery time and low forward-voltage drop. Ensure that the diode's average and peak current rating exceed the average output current and peak inductor current. In addition, the diode's reverse breakdown voltage must exceed the

maximum output voltage.

PCB Board Layout

Due to fast switching waveform and high-current paths (VIN, SW), careful PCB board layout is required. An evaluation kit is available to speed design. When laying out a board, minimize trace lengths between the chip and RISNS, the inductor, the diode, the input capacitor, and the output capacitor. Keep traces short, direct, and wide. Keep noisy traces, such as the SW node trace, away from RISNS. The ground connections of input capacitor C1 and output capacitor C2 should be as close as possible.

PACKAGE INFORMATION

SOP-8 PACKAGE OUTLINE AND DIMENSIONS

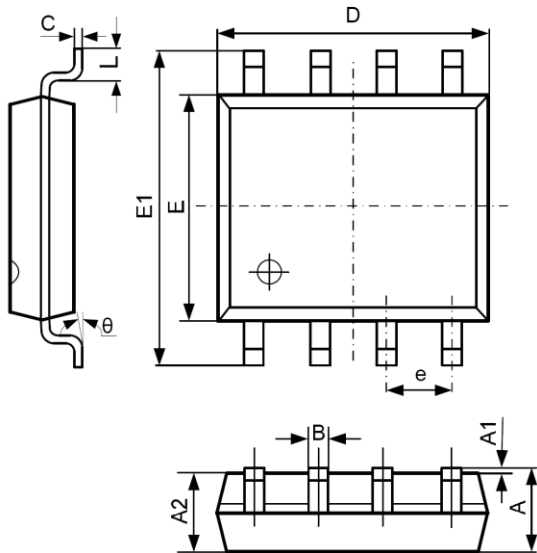

SYMBOL	DIMENSION IN MILLIMETERS		DIMENSION IN INCHES	
	MIN	MAX	MIN	MAX
A	1.350	1.750	0.053	0.069
A1	0.100	0.250	0.004	0.010
A2	1.350	1.550	0.053	0.061
B	0.330	0.510	0.013	0.020
C	0.190	0.250	0.007	0.010
D	4.700	5.100	0.185	0.201
E	3.800	4.000	0.150	0.157
E1	5.800	6.300	0.228	0.248
e	1.270 TYP		0.050 TYP	
L	0.400	1.270	0.016	0.050
θ	0°	8°	0°	8°



Maximizing IC Performance

MT7261

**Boost White LED Driver
With High Frequency PWM Dimming**

For detail products information and sample requests, please contact:

Maxic Technology Corporation (Beijing Office)

1006, Crown Plaza Office Tower, No106, ZhiChun Road, Hai Dian District, Beijing, China, 100086

Tel: 86-10-62662828

Fax: 86-10-62662951

Maxic Technology Coporation (Shenzhen office)

25BC, Fortune Plaza, Futian District, Shenzhen 518040

Tel: 86-755-83021778

Fax: 86-755-83021336

Maxic Technology Coporation (Suzhou office)

B-503, Chuangye Park 3, 328 Xinghu Street, Industrial Park, Suzhou 215021

Tel: 86-512-62958262

Fax: 86-512-62958262

Maxic Technology Corporation(Hong Kong office)

Rm D1, 7th floor, JianAn Commercial Building,

No. 49-51, Suhong Str., Sheung Wan, Hong Kong

Web: www.maxictech.com

E-mail: sales@maxictech.com, info@maxictech.com