

DESCRIPTION

MT7603 is a high voltage linear constant-current LED driver. It's designed to drive LED string directly from 110VAC/220VAC mains.

The system can easily pass EMI without inductor, transformer or other magnetic components, it can achieve simplified peripheral circuit and low BOM cost. The application of high power can be achieved by controlling the MOS temperature.

The output current can be set by external resistor. With Maxic's proprietary linear compensation technology, MT7603 can achieve constant power output when the input voltage is variable.

FEATURES

- Supports high power application with external MOS
- High precision constant current
- Supports linear voltage compensation
- Both of With/without electrolytic capacitor schemes are supported
- High power factor application
- Low EMI interference
- Available in SOT23-6 package

APPLICATION

- Fluorescent, candle lamp
- Bulb, decorative lamp
- Street lamp

Typical Application Circuit

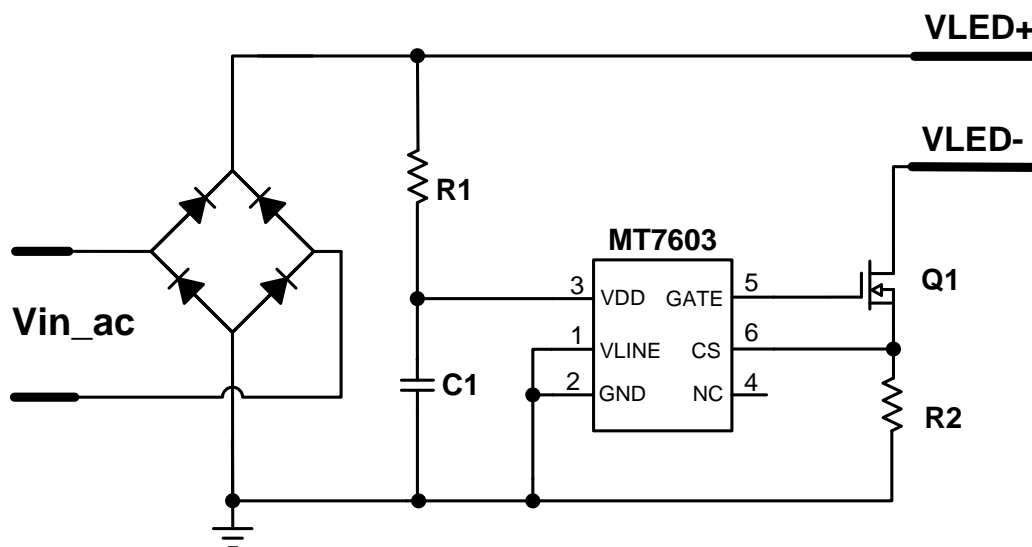

ABSOLUTE MAXIMUM RATINGS

VDD pin voltage	-0.3V ~ 20V
CS, VLINE pin voltage	-0.3V ~ 6V
GATE pin voltage	-0.3V ~ 20V
Storage Temperature	-55°C~150°C
Junction Temperature (Tj)	150°C

RECOMMENDED OPERATING CONDITIONS

Supply voltage VDD	15V
Operating Temperature	-40°C~105°C

THERMAL RESISTANCE

Junction to ambient (R θ JA)	170°C/W
-------------------------------------	---------

PIN CONFIGURATIONS

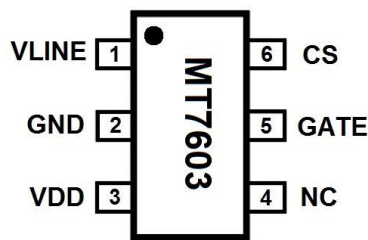

Chip Mark

7603xYW

— Manufacture code
— Week code
— Year code

Pin description

Name	Pin No	Description
VLINE	1	Linear compensation pin. If this pin connects to ground directly, the linear voltage compensation is unavailable
GND	2	Chip ground
VDD	3	Power supply pin
NC	4	No connection
GATE	5	Gate of the internal MOSFET
CS	6	Current sense pin

ELECTRICAL CHARACTERISTICS

(Test conditions: VDD=15V, TA=25°C unless otherwise stated)

Symbol	Parameter		Min	Typ	Max	Unit
Start-up and power supply voltage (VDD Pin)						
V _{START}	Start-up voltage	VDD voltage ramp up		12		V
UVLO	Under voltage lockout threshold voltage	VDD voltage ramp down		9		V
V _{CLAMP}	VDD clamp voltage			15		V
Supply current						
I _{START}	Start-up current			100		uA
I _{VDD}	Operating current			200		uA
Current sense (CS Pin)						
V _{REF}	Peak current detection threshold			500		mV
Over Temperature Protection						
T _{fold}	Over temperature protection			140		°C
I _{slope}	Slope of output current decrease			4		%/°C

MT7603 TYPICAL APPLICATION (220VAC)

Input Power	PF	LED Output Voltage (V)	Average Output Current (mA)	Typical Efficiency
18W	0.9	250V	60mA	84%

BLOCK DIAGRAM

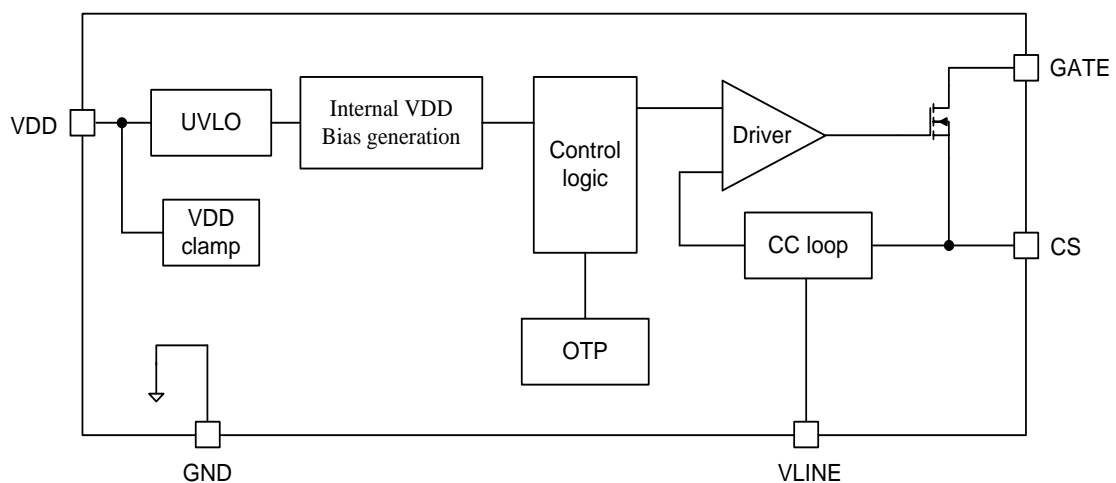

APPLICATION INFORMATION

MT7603 is a linear constant-current LED driver. It can achieve accurate constant-current at specific operating voltage range with less peripheral components.

Start Up

During start-up, VDD is charged through a start-up resistor. As VDD reaches 12V, the control logic starts to work. As the VDD continues rising up to 15V, it will be clamped. When the VDD voltage drops to below 9V, the system shuts down, and the UVLO function is triggered. As shown in Fig.1.

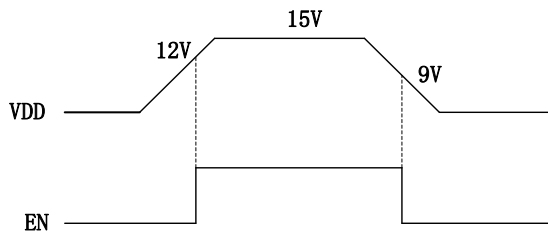

Fig.1 Start up and close sequence

Output Current and Voltage Determination

It is important to determine the LED voltage and current, As MT7603 is a linear buck LED driver IC, the peak value of the rectified input voltage must be greater than the output LED voltage.

Refer to Fig.2, MT7603 automatically turns on the LED string following the input sine wave. When the input voltage rises and reaches to the LED conducting voltage V_{LED} , The LED string is turned on. Since then, the input voltage continues rising, the LED string voltage keeps stable, the external MOSFET bears the superfluous voltage drop. If the input voltage drops, the procedure is reversed. So high LED voltage makes the LED availability to be low, and low LED voltage will reduce the system efficiency. It is recommended to choose about 120V high-voltage LED string in 120VAC applications; And to choose about 250V high-voltage LED

string in 220VAC applications. It can be adjusted according to actual application.

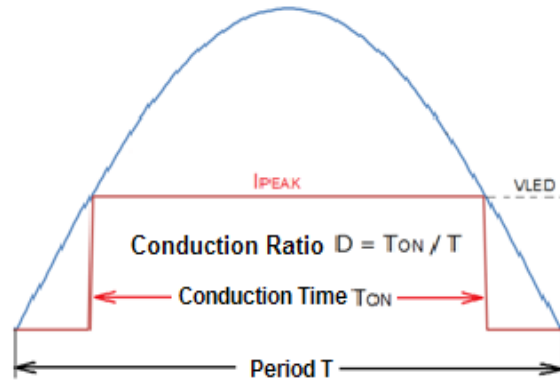

Fig.2 LED conduction procedure

Sense Resistor Settings

The output current be set by the sense resistor R_{CS} . MT7603 generates a control signal by comparing the voltage on sense resistor R_{CS} and internal reference voltage V_{REF} (500mV) to achieve LED constant current output.

The peak current of LED light string:

$$I_{PAEK} = \frac{V_{REF}}{R_{CS}} = \frac{500mV}{R_{CS}} \quad (1)$$

Fig.2 shows the LED conduction procedure, MT7603 actually controls the LED peak current during the conduction-time.

There are two cases in real application:

- 1) No large electrolytic capacitor is needed after the rectifier bridge, as shown in Fig.2. At the valley, the input voltage is lower than LED string forward voltage, the output current is zero. When the input voltage is higher than the LED string forward voltage, the output current is I_{PEAK} . So, in the real application, the LED string current is discontinuous, and the I_{LED} is the average LED string current.

$$I_{LED} = I_{PEAK} \times D \quad (2)$$

Where, D is the LED string conduction ratio.

Linear Constant – Current LED Driver

In general, $D \approx 0.5$, so $I_{LED} \approx 0.5 \times I_{PEAK}$.

The final average LED current needs to be fine tuned/trimmed according to the measured results. In this case, the system power factor (PF) can reach more than 0.9. But the LED output current will increase with the input voltage.

- There is an electrolytic capacitor after the rectifier bridge. After rectifying, the input voltage substantially closes to DC voltage. So, the LED output current equals to the peak current, $I_{LED} = I_{PEAK}$, as calculated in Equation (1). In this case, the output current is stable. But power factor is relatively lower.

Power Consumption and Heat Dissipation

The voltage difference between input voltage and output LED voltage can generate power consumption, which is all undertaken by the external power MOSFET. Hence the LED string voltage and input voltage should be properly

configured to guarantee the power consumption in a controllable range, or carry on other effective thermal design solutions. For example to choose the MOSFET in better heat dissipation package, and to add a radiator for MOSFET, etc.

Over Temperature Protection

When the junction temperature exceeds T_{fold} (typically 140°C), the LED output current is gradually reduced. Thus, the output power and thermal dissipation are also reduced, so as to protect the LED lamps, and be able to extend the system life. When the temperature is higher than T_{fold} , the drop slope for the output current with the temperature is about $4\%/^\circ\text{C}$.

Linear Compensation

MT7603 integrates Maxim proprietary linear compensation technique. The input voltage is detected by the VLINE pin through a resistor divider R1, R3, R4. The output current is compensated when the input voltage varies, so that the input power keeps stable. As shown in Fig3.

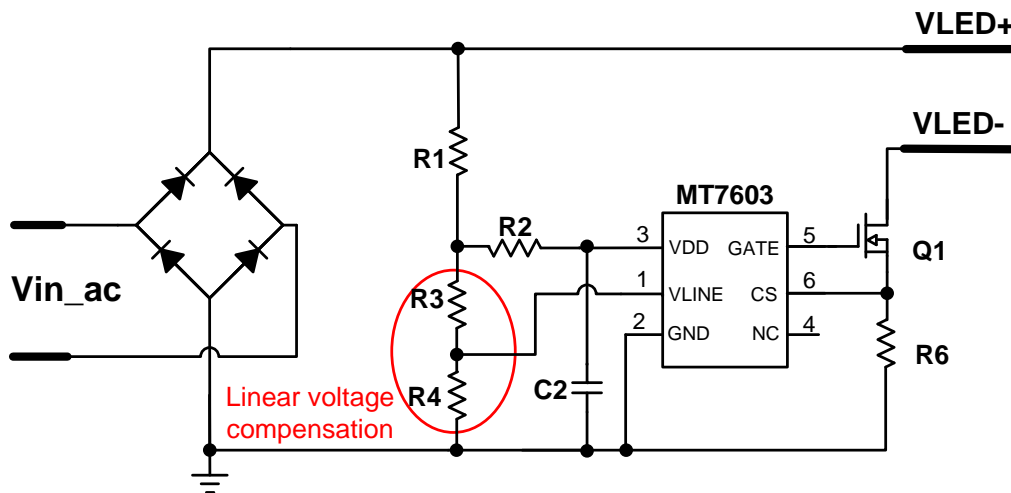
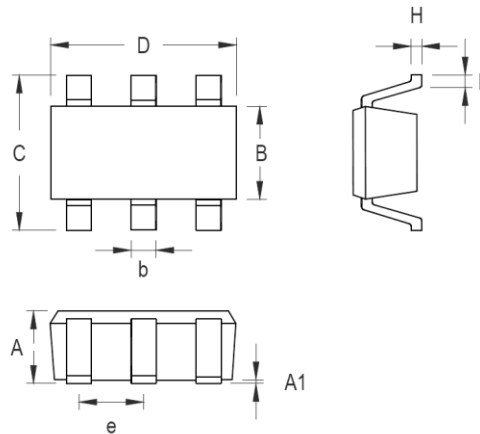

Fig.3 Linear compensation application circuit

PACKAGE INFORMATION

SOT-23-6



Symbol	Dimensions In Millimeters		Dimensions In Inches	
	Min	Max	Min	Max
A	0.889	1.295	0.035	0.051
A1	0.000	0.152	0.000	0.006
B	1.397	1.803	0.055	0.071
b	0.250	0.559	0.010	0.022
C	2.591	2.997	0.102	0.118
D	2.692	3.099	0.106	0.122
e	0.838	1.041	0.033	0.041
H	0.080	0.254	0.003	0.010
L	0.300	0.610	0.012	0.024

Important Notice

- Maxic Technology Corporation (Maxic) reserve the right to make correction, modifications, enhancements, improvements and other changes to its products and services at any time and to discontinue any product or service without notice. Customers should obtain the latest relevant information before placing orders and should verify that such information is current and complete. All products are sold subject to Maxic’s terms and conditions of sale supplied at the time of order acknowledgement.
- Reproduction, copying, transferring, reprinting this paper without Maxic’s written permission is prohibited.
- Maxic is not responsible or liable for customer product design by using Maxic components. To minimize the risks and associated with customer products and applications, customers should provide adequate design and operating safeguards and consult Maxic’s sales department.