



everyday genius

MediaTek MT7688 Datasheet

Version: 1.4

Release date: 15th April 2016

© 2016 MediaTek Inc.

This document contains information that is proprietary to MediaTek Inc. ("MediaTek") and/or its licensor(s). MediaTek cannot grant you permission for any material that is owned by third parties. You may only use or reproduce this document if you have agreed to and been granted explicit permission within the "License Agreement" that is available on MediaTek's website ("Permitted User"). If you are not a Permitted User, please cease any access or use of this document immediately. Any unauthorized use, reproduction or disclosure of this document in whole or in part is strictly prohibited. For more information, please consult your legal advisor. Specifications contained herein are subject to change without notice.

Document Revision History

Revision	Date	Description
1.0	9 th July 2012	Initial Release
1.1	18 th July 2012	Updated SPI_WP/SPI_HOLD table
1.2	20 th August 2012	Fixed DRQFN internal pad size typo
1.3	12 th September 2012	Added IR reflow guideline
1.4	15 th April 2016	Added registers and controller information

Table of Contents

DOCUMENT REVISION HISTORY	2
1. OVERVIEW	7
1.1 FEATURES	7
2. MAIN FEATURES	9
3. PINS	10
3.1 MT7688AN DR-QFN (12 MM X 12 MM) 156-PIN PACKAGE DIAGRAM	10
3.1.1 UP-LEFT SIDE	10
3.1.2 DOWN-LEFT SIDE	11
3.1.3 DOWN-RIGHT SIDE	12
3.1.4 UP-RIGHT SIDE	13
3.1.5 PIN DESCRIPTION	14
3.2 MT7688KN DR-QFN (10 MM X 10 MM) 120-PIN PACKAGE DIAGRAM	20
3.2.1 LEFT SIDE VIEW	20
3.2.2 RIGHT SIDE VIEW	21
3.2.3 PIN DESCRIPTION	22
3.3 PIN SHARING SCHEMES	25
3.3.1 GPIO PIN SHARE SCHEME	25
3.3.2 UART1 PIN SHARE SCHEME	26
3.3.3 MT7688AN EPHY LED PIN SHARE SCHEME	26
3.3.4 MT7688AN WLAN LED PIN SHARE SCHEME	27
3.3.5 MT7688KN EPHY LED PIN SHARE SCHEME	27
3.3.6 MT7688KN WLAN LED PIN SHARE SCHEME	27
3.3.7 PERST_N PIN SHARE SCHEME	27
3.3.8 WDT_RST_N PIN SHARE SCHEME	27
3.3.9 REF_CLKO PIN SHARE SCHEME	28
3.3.10 UART0 PIN SHARE SCHEME	28
3.3.11 GPIO0 PIN SHARE SCHEME	28
3.3.12 SPI PIN SHARE SCHEME	28
3.3.13 SPI_CS1 PIN SHARE SCHEME	28
3.3.14 I2C PIN SHARE SCHEME	28
3.3.15 I2S PIN SHARE SCHEME	28
3.3.16 SD PIN SHARE SCHEME	29
3.3.17 EMMC PIN SHARE SCHEME	29
3.3.18 UART2 PIN SHARE SCHEME	29
3.3.19 PWM_CHO PIN SHARE SCHEME	29
3.3.20 PWM_CH1 PIN SHARE SCHEME	29
3.3.21 SPIS PIN SHARE SCHEME	30
3.3.22 PIN SHARE FUNCTION DESCRIPTION	30
3.4 BOOTSTRAPPING PINS DESCRIPTION	30
4. MAXIMUM RATINGS AND OPERATING CONDITIONS	32
4.1 ABSOLUTE MAXIMUM RATINGS	32
4.2 MAXIMUM TEMPERATURES	32
4.3 OPERATING CONDITIONS	32
4.4 THERMAL CHARACTERISTICS	32
4.5 STORAGE CONDITIONS	32
4.6 EXTERNAL XTAL SPECIFICATION	33
4.7 DC ELECTRICAL CHARACTERISTICS	33
4.8 AC ELECTRICAL CHARACTERISTICS	34
4.8.1 DDR2 SDRAM INTERFACE	35
4.8.2 SPI INTERFACE	37
4.8.3 I ² S INTERFACE	38
4.8.4 PCM INTERFACE	39

4.8.5 POWER ON SEQUENCE	40
4.9 PACKAGE PHYSICAL DIMENSIONS	40
4.9.1 DR-QFN (10 MM X 10 MM) 128 PINS	40
4.9.2 DR-QFN (12 MM X 12 MM) 156 PINS	43
4.9.3 MT7688 AN/KN MARKING	46
4.9.4 REFLOW PROFILE GUIDELINE	47
5. REGISTER	48
5.1 NOMENCLATURE	48
5.2 SYSTEM CONTROL	49
5.2.1 FEATURES	49
5.2.2 BLOCK DIAGRAM	49
5.2.3 REGISTERS	50
5.3 TIMER	66
5.3.1 FEATURES	66
5.3.2 BLOCK DIAGRAM	66
5.3.3 REGISTERS	66
5.4 INTERRUPT CONTROLLER	72
5.4.1 REGISTERS	72
5.5 EMC CONTROLLER	79
5.5.1 REGSITER	79
5.6 R-BUS CONTROLLER	95
5.6.1 FEATURES	95
5.6.2 BLOCK DIAGRAM	95
5.6.3 REGSITER	95
5.7 MIPS CNT	105
5.7.1 REGISTERS	105
5.8 GENERAL PURPOSE IO	107
5.8.1 FEATURES	107
5.8.2 BLOCK DIAGRAM	107
5.8.3 GPIO PIN MAPPING	108
5.8.4 REGISTER	108
5.9 SPI SLAVE	121
5.9.1 SPI SLAVE CONTROL	121
5.9.2 REGSITERS	123
5.10 I ² C CONTROLLER	125
5.10.1 FEATURES	125
5.10.2 LIST OF REGISTERS	125
5.11 I2S CONTROLLER	131
5.11.1 FEATURES	131
5.11.2 BLOCK DIAGRAM	131
5.11.3 REGISTERS	132
5.12 SPI CONTROLLER	138
5.12.1 FEATURES	138
5.12.2 BLOCK DIAGRAM	138
5.12.3 REGISTERS	138
5.13 UART LITE	149
5.13.1 FEATURES	149
5.13.2 REGISTERS	149
5.14 PCM CONTROLLER	162
5.14.1 FEATURES	162
5.14.2 BLOCK DIAGRAM	162
5.14.3 LIST OF REGISTERS	163

5.14.4 PCM CONFIGURATION	163
5.14.5 REGISTER	164
5.15 GENERIC DMA CONTROLLER	180
5.15.1 FEATURES	180
5.15.2 BLOCK DIAGRAM	180
5.15.3 PERIPHERAL CHANNEL CONNECTION	180
5.15.4 REGISTERS	181
5.16 AES CONTROLLER	225
5.16.1 REGISTERS	225
5.17 PWM (PULSE WIDTH MODULATION)	233
5.17.1 REGISTERS	233
5.18 FRAME ENGINE	249
5.18.1 REGISTERS	249
5.19 SWITCH CONTROLLER	267
5.19.1 REGISTERS	267
6. ABBREVIATIONS	314

Table of Figures

FIGURE 1-1 IoT DEVICE MODE FUNCTIONAL BLOCK DIAGRAM	8
FIGURE 1-2 IoT GATEWAY MODE FUNCTIONAL BLOCK DIAGRAM	8
FIGURE 3-1 MT7688AN DR-QFN PIN DIAGRAM (UP-LEFT VIEW)	10
FIGURE 3-2 MT7688AN DR-QFN PIN DIAGRAM (DOWN-LEFT VIEW)	11
FIGURE 3-3 MT7688AN DR-QFN PIN DIAGRAM (DOWN-RIGHT VIEW)	12
FIGURE 3-4 MT7688AN DR-QFN PIN DIAGRAM (UP-RIGHT VIEW)	13
FIGURE 3-5 MT7688KN DR-QFN PIN DIAGRAM (LEFT VIEW)	20
FIGURE 3-6 MT7688KN DR-QFN PIN DIAGRAM (RIGHT SIDE VIEW)	21
FIGURE 4-1 DDR2 SDRAM COMMAND	35
FIGURE 4-2 DDR2 SDRAM WRITE DATA	35
FIGURE 4-3 DDR2 SDRAM READ DATA	35
FIGURE 4-4 SPI INTERFACE	37
FIGURE 4-5 I2S INTERFACE	38
FIGURE 4-6 PCM INTERFACE	39
FIGURE 4-7 POWER ON SEQUENCE	40
FIGURE 4-8 TOP VIEW	40
FIGURE 4-9 SIDE VIEW	41
FIGURE 4-10 "B" EXPANDED	41
FIGURE 4-11 BOTTOM VIEW	42
FIGURE 4-12 TOP VIEW	43
FIGURE 4-13 SIDE VIEW	44
FIGURE 4-14 "B" EXPANDED	44
FIGURE 4-15 BOTTOM VIEW	45
FIGURE 4-16 MT7688AN TOP MARKING	47
FIGURE 4-17 MT7688KN TOP MARKING	47
FIGURE 4-18 REFLOW PROFILE FOR MT7688	47
FIGURE 5-1 SYSTEM CONTROL BLOCK DIAGRAM	49
FIGURE 5-2 TIMER BLOCK DIAGRAM	66
FIGURE 5-3 QoS ARBITRATION BLOCK DIAGRAM	95
FIGURE 5-4 PROGRAMMABLE I/O BLOCK DIAGRAM	107
FIGURE 5-5 I ² S TRANSMITTER BLOCK DIAGRAM	131
FIGURE 5-6 I2S TRANSMIT/RECEIVE	131
FIGURE 5-7 SPI CONTROLLER BLOCK DIAGRAM	138
FIGURE 5-8 PCM CONTROLLER BLOCK DIAGRAM	162
FIGURE 5-9 GENERIC DMA CONTROLLER BLOCK DIAGRAM	180

List of Tables

TABLE 2-1 MAIN FEATURES.....	9
TABLE 4-1 ABSOLUTE MAXIMUM RATINGS	32
TABLE 4-2 MAXIMUM TEMPERATURES.....	32
TABLE 4-3 OPERATING CONDITIONS	32
TABLE 4-4 THERMAL CHARACTERISTICS	32
TABLE 4-5 EXTERNAL XTAL SPECIFICATIONS.....	33
TABLE 4-6 DC ELECTRICAL CHARACTERISTICS.....	33
TABLE 4-7 VDD 2.5V ELECTRICAL CHARACTERISTICS	33
TABLE 4-8 VDD 1.8V ELECTRICAL CHARACTERISTICS	33
TABLE 4-9 VDD 3.3V ELECTRICAL CHARACTERISTICS	34
TABLE 4-10 DDR2 SDRAM INTERFACE DIAGRAM KEY	36
TABLE 4-11 SPI INTERFACE DIAGRAM KEY	37
TABLE 4-12 I2S INTERFACE DIAGRAM KEY	38
TABLE 4-13 PCM INTERFACE DIAGRAM KEY	39
TABLE 4-14 POWER ON SEQUENCE DIAGRAM KEY.....	40
TABLE 5-1 THE IIR[5:0] CODES ASSOCIATED WITH THE POSSIBLE INTERRUPTS	150
TABLE 5-2 DIVISOR NEEDED TO GENERATE A GIVEN BAUD RATE	156
TABLE 5-3 DIVISOR NEEDED TO GENERATE A GIVEN BAUD RATE FROM 13MHZ BASED ON DIFFERENT HIGHSPEED VALUE	157
TABLE 5-4 DIVISOR NEEDED TO GENERATE A GIVEN BAUD RATE FROM 26 MHZ BASED ON DIFFERENT HIGHSPEED VALUE	158
TABLE 5-5 DIVISOR NEEDED TO GENERATE A GIVEN BAUD RATE FROM 52 MHZ BASED ON DIFFERENT HIGHSPEED VALUE	158

1. Overview

MediaTek MT7688 chipset integrates a 1T1R 802.11n Wi-Fi radio, a 580MHz MIPS® 24KEc™ CPU, 1-port fast Ethernet PHY, USB2.0 host, PCIe, SD-XC, I2S/PCM and multiple low-speed IOs in a single SOC. The MT7688 supports two operation modes – IoT gateway and IoT device mode. In IoT gateway mode, the PCIe interface can connect to an 802.11ac chipset and be used as an 11ac dual-band concurrent gateway. The high-performance USB 2.0 allows MT7688 to add 3G/LTE modem support or a H.264 ISP for wireless IP camera. The IoT gateway mode also supports touch panel and Bluetooth Low Energy, Zigbee/Z-Wave and Sub-1 GHz RF for smart home control. In IoT device mode, MT7688 supports eMMC, SD-XC and USB 2.0 in addition to Wi-Fi high quality audio via 192Kbps/24bits I2S interface and VoIP application through PCM, as well as peripheral interfaces including PWM, SPI slave, 3rd UART and more GPIOs.

1.1 Features

- Embedded MIPS24KEc (575/580 MHz) with 64 KB I-Cache and 32 KB D-Cache
- 1T1R 2.4 GHz with 150 Mbps PHY data rate
- Legacy 802.11b/g and HT 802.11n modes
- 20/40 MHz channel bandwidth
- 802.11v
- Space Time Block Coding (STBC)
- 16-bit DDR1/2 up to 128/256 Mbytes
- x1 USB 2.0 Host, x1 PCIe Root Complex
- 1-port 10/100 FE PHY
- SD-XC, eMMC, I2C, PCM, I2S(192K/24bits), PWM, SPI master/slave, UART lite, JTAG, GPIO
- Internet Of Things
- Embedded PMU
- Green AP/STA
 - Intelligent Clock Scaling (exclusive)
 - DDRII: ODT off, Self-refresh mode
- QoS: WMM, WMM-PS
- 16 Multiple BSSID
- iPA/iLNA and ePA/eLNA
- 24 STA-Proxy
- AES128/256-CBC
- WEP64/128, TKIP, AES, WPA, WPA2, WAPI
- WPS: PBC, PIN
- AP/STA Firmware: Linux 2.6.36 SDK, OpenWrt 3.10 SDK, eCOS with IPv6

Figure 1-1 illustrates the function diagram in IoT device mode.

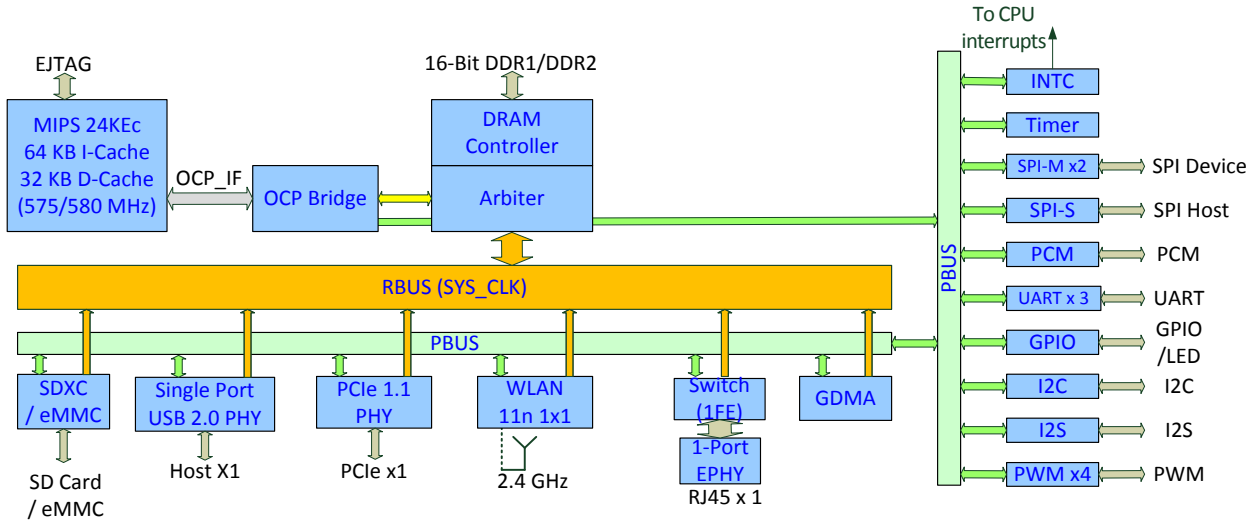

Figure 1-1 IoT Device Mode Functional Block Diagram

Figure 1-2 illustrates the functional block diagram in IoT gateway mode.

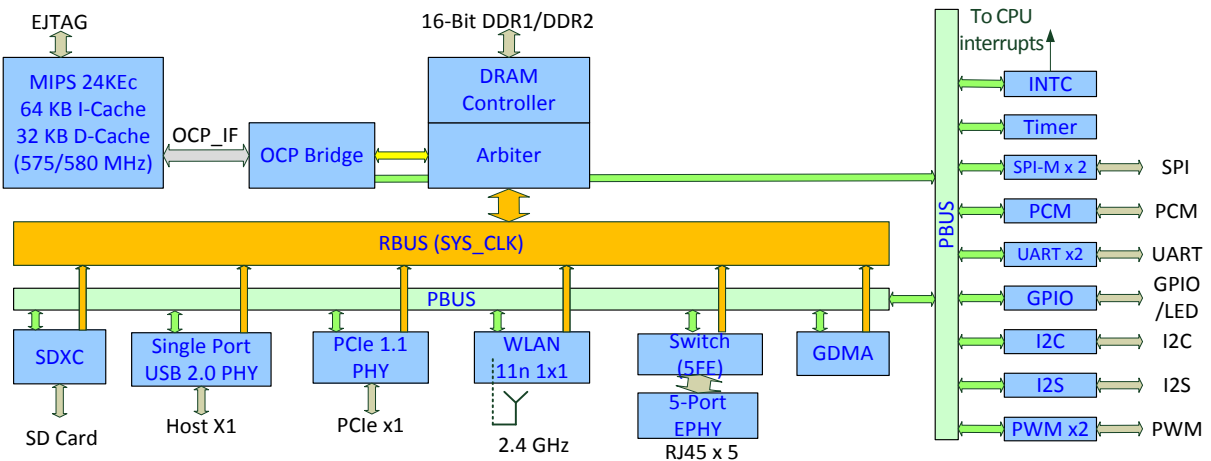

Figure 1-2 IoT Gateway Mode Functional Block Diagram

2. Main Features

The following table covers the main features offered by the MT7688KN and MT7688AN. Overall, the MT7688KN supports the requirements of an entry-level AP/router, while the more advanced MT7688AN supports a number of interfaces together with a large maximum RAM capacity.

Features	MT7688KN	MT7688AN
CPU	MIPS24KEc (580 MHz)	MIPS24KEc (580 MHz)
Total DMIPs	580 x 1.6 DMIPs	580 x 1.6 DMIPs
I-Cache, D-Cache	64 KB, 32 KB	64 KB, 32 KB
L2 Cache	n/a	n/a
Memory		
DRAM Device width support	16 bits	16 bits
DDR1	64 Mb (MCM), 193 MHz	2 Gb, 193 MHz
DDR2	n/a	2 Gb, 193 MHz
SPI Flash	3B addr mode (max 128Mbit) 4B addr mode (max 512Mbit)	3B addr mode (max 128Mbit) 4B addr mode (max 512Mbit)
SD	n/a	SD-XC (class 10)
RF	1T1R 802.11n 2.4 GHz	1T1R 802.11n 2.4 GHz
PCIe	1	1
USB 2.0	1	1
Switch	5p FE SW	5p FE SW
I2S	1	1
PCM	1	1
I2C	1	1
UART	2 (Lite)	2 (Lite)
JTAG	1	1
Package	DR-QFN120- 10 mm x 10 mm	DR-QFN156- 12 mm x 12 mm

Table 2-1 Main Features

3. Pins

3.1 MT7688AN DR-QFN (12 mm x 12 mm) 156-Pin Package Diagram

3.1.1 Up-left side

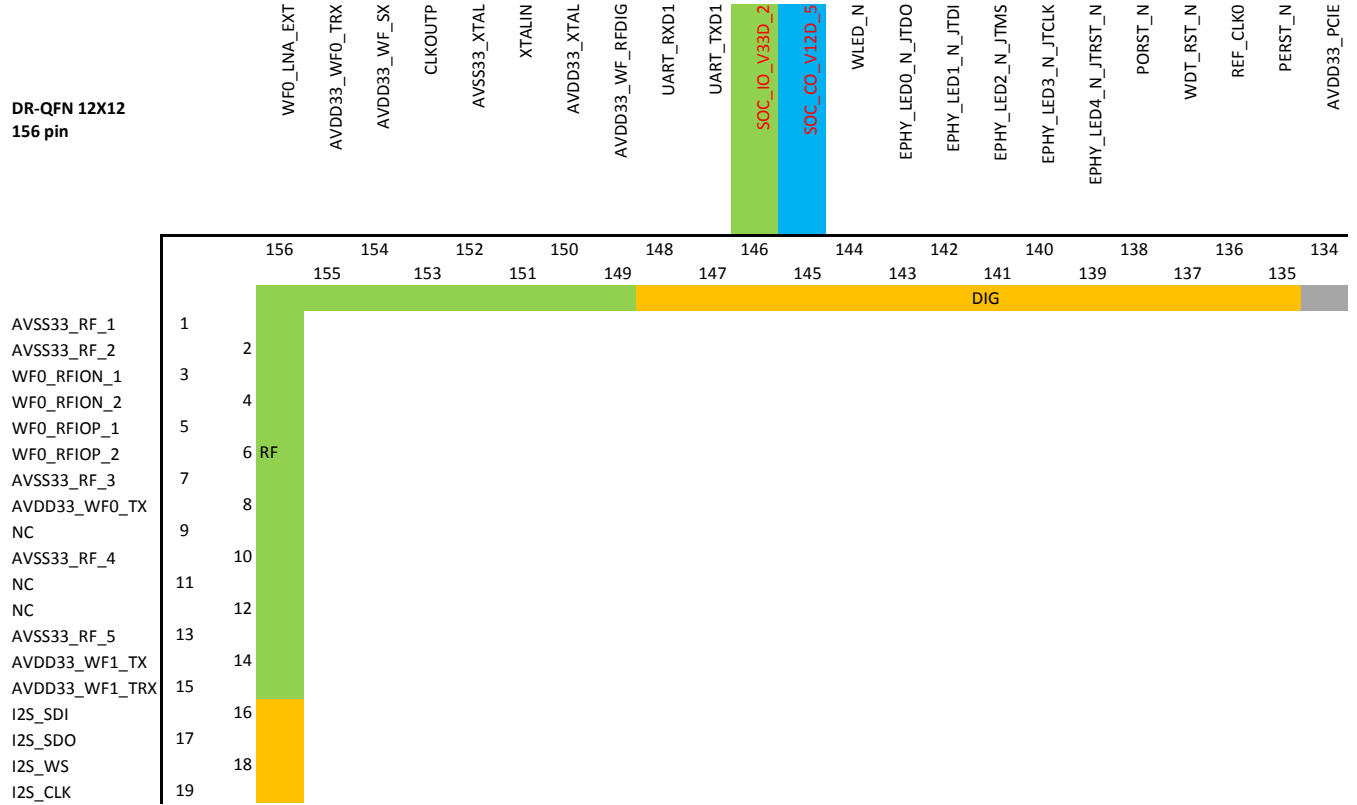

Figure 3-1 MT7688AN DR-QFN Pin Diagram (up-left view)

3.1.2 Down-left side

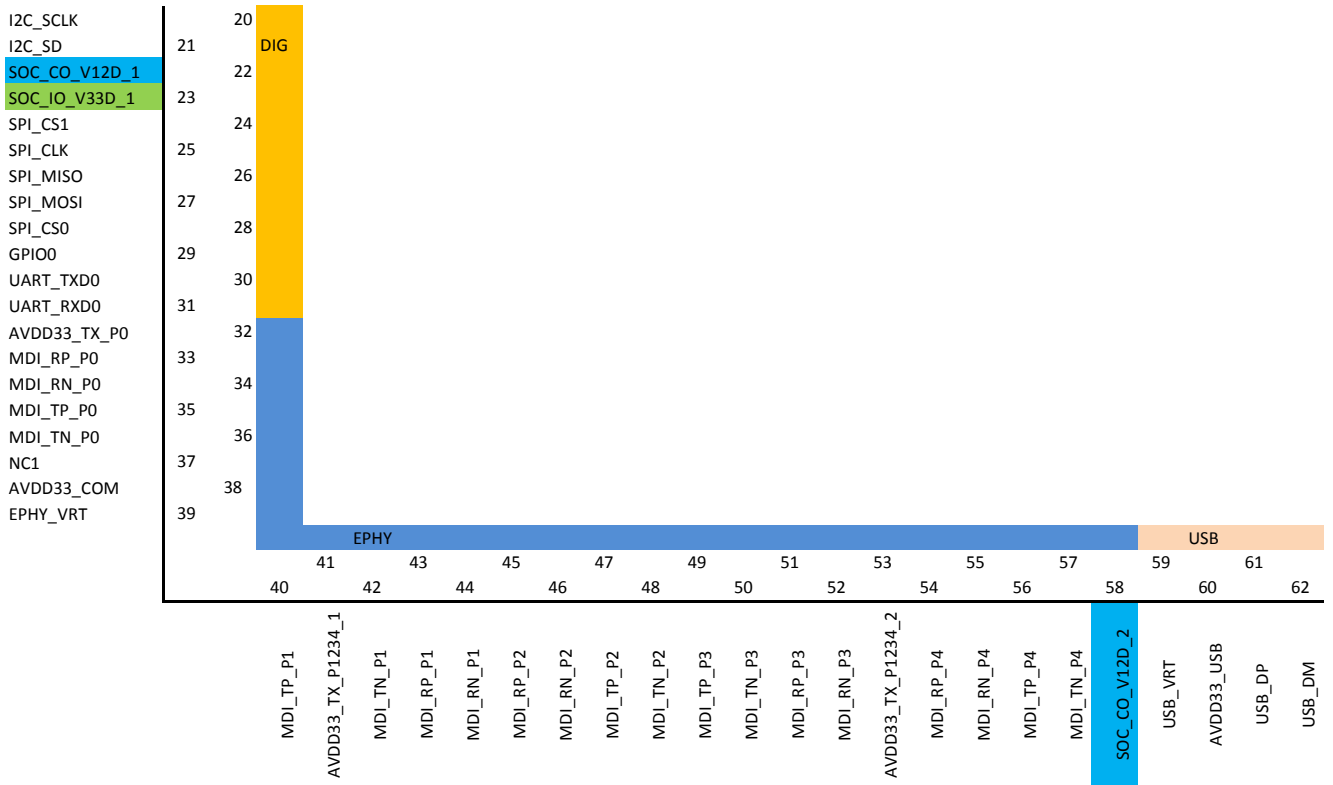

Figure 3-2 MT7688AN DR-QFN Pin Diagram (down-left view)

3.1.3 Down-right side

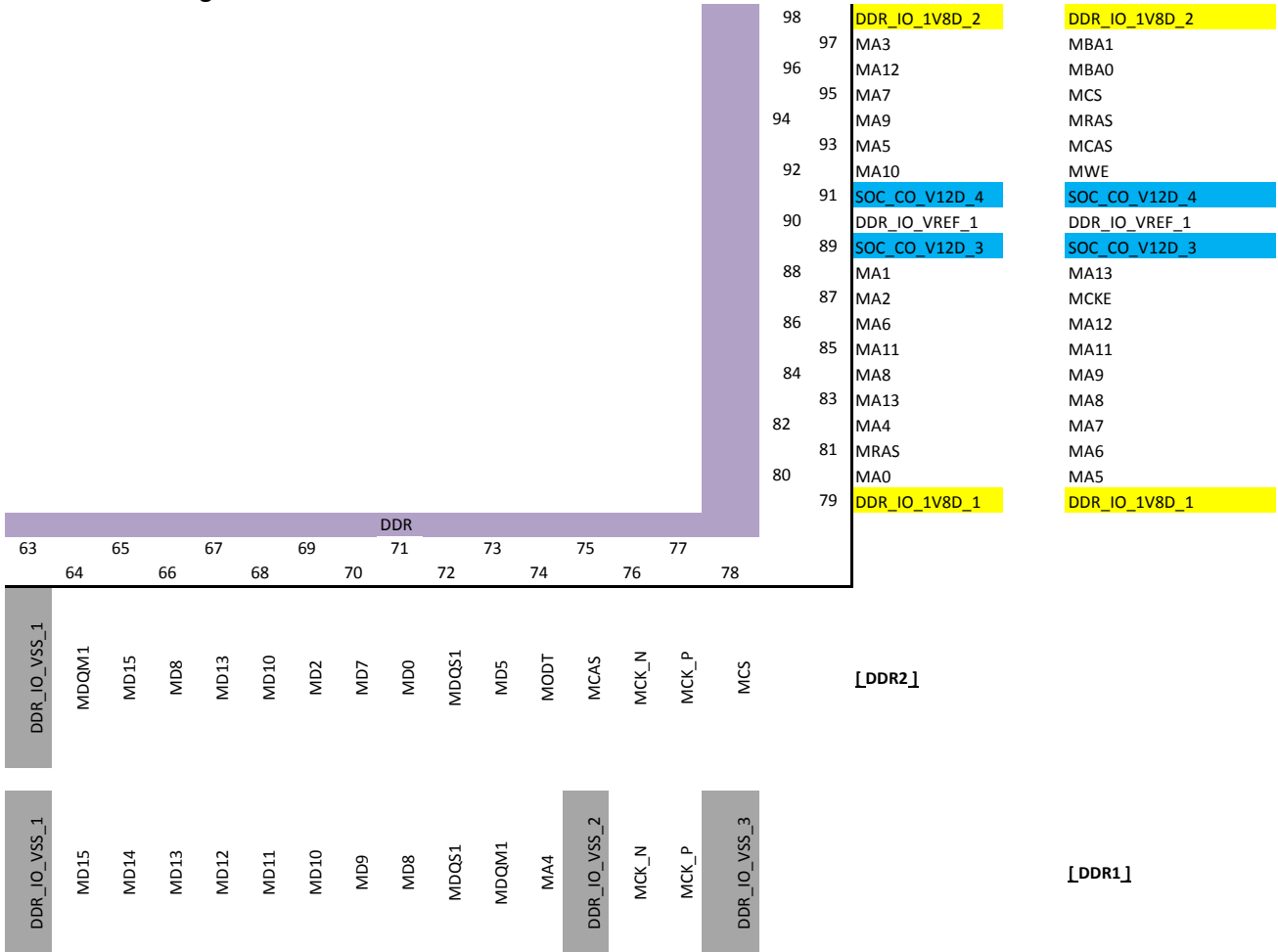

Figure 3-3 MT7688AN DR-QFN Pin Diagram (down-right view)

Note: DR-QFN support DDR1 and DDR2 pin shuffle depend on the bootstrap.

3.1.4 Up-right side

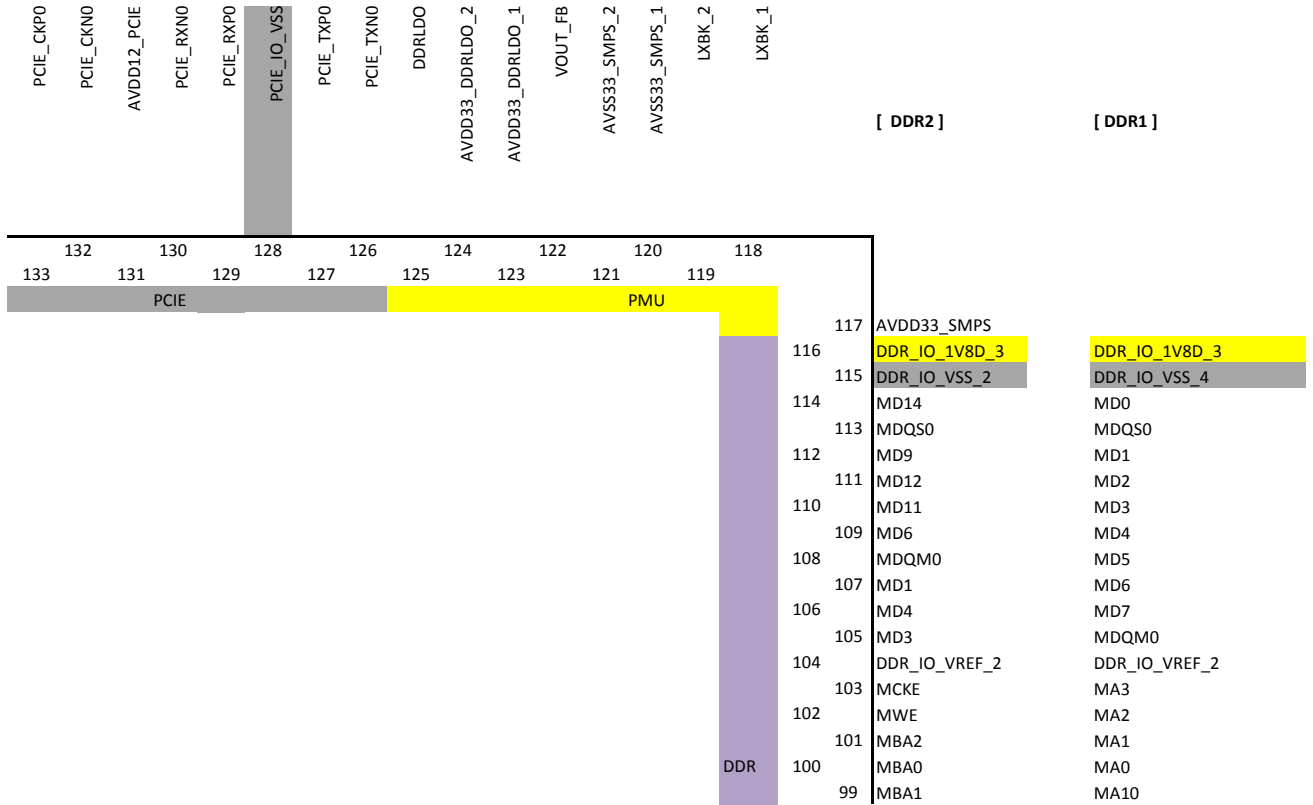

Figure 3-4 MT7688AN DR-QFN Pin Diagram (up-right view)

3.1.5 Pin Description

Pins	Name	Type	Driv.	Description
RF				
3,4	WF0_RFION_1 WF0_RFION_2	A		WF0 main path RF I/O
5,6	WF0_RFIOP_1 WF0_RFIOP_2	A		WF0 main path RF I/O
11	NC			
12	NC			
9	NC			
156	WF0_LNA_EXT	A		WF0 aux. path LNA input
151	XTALIN	I		Crystal oscillator input
153	CLKOUTP	O		XO reference clock output
150	AVDD33_XTA	P		3.3V XTAL Power Supply Pin
152	AVSS33_XTAL	G		3.3V XTAL Ground Pin
8	AVDD33_WF0_TX	P		3.3V RF Channel 0 Supply Power
14	AVDD33_WF1_TX	P		3.3V RF Channel 1 Supply Power
15	AVDD33_WF1_TRX	P		1.65V to 3.3V RF Channel 1 Supply Power
149	AVDD33_WF_RFDIG	P		1.65V to 3.3V RF DIG and AFE Supply Power
154	AVDD33_WF_SX	P		1.65V to 3.3V RF Supply Power
155	AVDD33_WF0_TRX	P		1.65V to 3.3V RF Channel 0 Supply Power
1,2 7, 10,13	AVSS33_RF	G		3.3V RF Shielding Ground Pin
WLAN LED				
144	WLED_N	O	4 mA	WLAN Activity LED
UART0 Lite				
31	RXD0	I	4 mA	UART0 Lite RXD
30	TXD0	O, IPD	4 mA	UART0 Lite TXD
UART1 Lite				
147	TXD1	O, IPU	4 mA	UART1 Lite TXD
148	RXD1	I	4 mA	UART1 Lite RXD
I2S				
16	I2S_SDI	I	4 mA	I2S data input
17	I2S_SDO	O, IPD	4 mA	I2S data output
18	I2S_WS	I/O	4 mA	I2S word select
19	I2S_CLK	I/O	4 mA	I2S clock
I2C				
21	I2C_SD	I/O	4 mA	I2C Data
20	I2C_SCLK	I/O	4 mA	I2C Clock
SPI				
26	SPI_MISO	I/O	4 mA	SPI Master input/Slave output
27	SPI_MOSI	I/O, IPD	4 mA	SPI Master output/Slave input
25	SPI_CLK	O, IPU	4 mA	SPI clock
28	SPI_CS0	O	4 mA	SPI chip select0
24	SPI_CS1	O, IPD	4 mA	SPI chip select1

Pins	Name	Type	Driv.	Description
GPIO				
29	GPIO0	I/O, IPD	4 mA	General Purpose I/O
5-Port EPHY				
143	EPHY_LED0_N_JTDO	I/O	4 mA	10/100 PHY Port #0 activity LED, JTAG_TDO
142	EPHY_LED1_N_JTDI	I/O	4 mA	10/100 PHY Port #1 activity LED, JTAG_TDI
141	EPHY_LED2_N_JTMS	I/O	4 mA	10/100 PHY Port #2 activity LED, JTAG_TMS
140	EPHY_LED3_N_JTCLK	I/O	4 mA	10/100 PHY Port #3 activity LED, JTAG_CLK
139	EPHY_LED4_N_JTRST_N	I/O,	4 mA	10/100 PHY Port #4 activity LED, JTAG_TRST_N
39	EPHY_VRT	A		Connect to an external resistor to provide accurate bias current
33	MDI_RP_P0	A		10/100 PHY Port #0 RXP
34	MDI_RN_P0	A		10/100 PHY Port #0 RXN
35	MDI_TP_P0	A		10/100 PHY Port #0 TXP
36	MDI_TN_P0	A		10/100 PHY Port #0 TXN
40	MDI_TP_P1	A		General purpose IO (SD-XC, eMMC...etc)
42	MDI_TN_P1	A		General purpose IO (SD-XC, eMMC...etc)
43	MDI_RP_P1	A		General purpose IO (SD-XC, eMMC...etc)
44	MDI_RN_P1	A		General purpose IO (SD-XC, eMMC...etc)
45	MDI_RP_P2	A		General purpose IO (SD-XC, eMMC...etc)
46	MDI_RN_P2	A		General purpose IO (SD-XC, eMMC...etc)
47	MDI_TP_P2	A		General purpose IO (SD-XC, eMMC...etc)
48	MDI_TN_P2	A		General purpose IO (SD-XC, eMMC...etc)
49	MDI_TP_P3	A		General purpose IO (SD-XC, eMMC...etc)
50	MDI_TN_P3	A		General purpose IO (SD-XC, eMMC...etc)
51	MDI_RP_P3	A		General purpose IO (SD-XC, eMMC...etc)
52	MDI_RN_P3	A		General purpose IO (SD-XC, eMMC...etc)
54	MDI_RP_P4	A		General purpose IO (SD-XC, eMMC...etc)
55	MDI_RN_P4	A		General purpose IO (SD-XC, eMMC...etc)
56	MDI_TP_P4	A		General purpose IO (SD-XC, eMMC...etc)
57	MDI_TN_P4	A		General purpose IO (SD-XC, eMMC...etc)
32	AVDD33_TX_P0	P		3.3V Supply Power for P0
38	AVDD33_COM	P		3.3V Supply Power for EPHY COM
41, 53	AVDD33_TX_P1234_1 AVDD33_TX_P1234_2	P		3.3V Supply Power for P1 ~ P4
Misc.				
136	REF_CLKO	O, IPD	4 mA	Reference Clock Ouptut
138	PORST_N	I, IPU	4 mA	Power on reset
137	WDT_RST_N	O	4 mA	Watchdog timeout reset
USB PHY				
60	AVDD33_USB	P		3.3 V USB PHY analog power supply
59	USB_VRT	I/O		Connect to an external 5.1 kΩ resistor for band-gap reference circuit
62	USB_DM	I/O		USB Port0 data pin Data-
61	USB_DP	I/O		USB Port0 data pin Data+

Pins	Name	Type	Driv.	Description
PCIe PHY				
135	PERST_N	O, IPD	4mA	PCIe device reset
134	AVDD33_PCIE	P		3.3 V PCIe PHY analog power supply
131	AVDD12_PCIE	P		1.2 V PCIe PHY digital power supply
128	PCIE_IO_VSS	G		PCIe PHY Ground Pin
133	PCIE_CKPO	I/O		External reference clock output (positive)
132	PCIE_CKN0	I/O		External reference clock output (negative)
127	PCIE_TXP0	I/O		PCIe0 differential transmit TX +
126	PCIE_TXN0	I/O		PCIe0 differential transmit TX -
129	PCIE_RXP0	I/O		PCIe0 differential receiver RX +
130	PCIE_RXN0	I/O		PCIe0 differential receiver RX -
DDR2				
65	MD15	I/O	8 mA	DDR2 Data bit #15
114	MD14	I/O	8 mA	DDR2 Data bit #14
67	MD13	I/O	8 mA	DDR2 Data bit #13
111	MD12	I/O	8 mA	DDR2 Data bit #12
110	MD11	I/O	8 mA	DDR2 Data bit #11
68	MD10	I/O	8 mA	DDR2 Data bit #10
112	MD9	I/O	8 mA	DDR2 Data bit #9
66	MD8	I/O	8 mA	DDR2 Data bit #8
70	MD7	I/O	8 mA	DDR2 Data bit #7
109	MD6	I/O	8 mA	DDR2 Data bit #6
73	MD5	I/O	8 mA	DDR2 Data bit #5
106	MD4	I/O	8 mA	DDR2 Data bit #4
105	MD3	I/O	8 mA	DDR2 Data bit #3
69	MD2	I/O	8 mA	DDR2 Data bit #2
107	MD1	I/O	8 mA	DDR2 Data bit #1
71	MD0	I/O	8 mA	DDR2 Data bit #0
83	MA13	O	8 mA	DDR2 Address bit #13
96	MA12	O	8 mA	DDR2 Address bit #12
85	MA11	O	8 mA	DDR2 Address bit #11
92	MA10	O	8 mA	DDR2 Address bit #10
94	MA9	O	8 mA	DDR2 Address bit #9
84	MA8	O	8 mA	DDR2 Address bit #8
95	MA7	O	8 mA	DDR2 Address bit #7
86	MA6	O	8 mA	DDR2 Address bit #6
93	MA5	O	8 mA	DDR2 Address bit #5
82	MA4	O	8 mA	DDR2 Address bit #4
97	MA3	O	8 mA	DDR2 Address bit #3
87	MA2	O	8 mA	DDR2 Address bit #2
88	MA1	O	8 mA	DDR2 Address bit #1
80	MA0	O	8 mA	DDR2 Address bit #0
101	MBA2	O	8 mA	DDR2 MBA #2
99	MBA1	O	8 mA	DDR2 MBA #1

Pins	Name	Type	Driv.	Description
100	MBA0	O	8 mA	DDR2 MBA #0
74	MODT	O	8 mA	DDR2 ODT
81	MRAS	O	8 mA	DDR2 MRAS_N
75	MCAS	O	8 mA	DDR2 MCAS_N
102	MWE	O	8 mA	DDR2 MWE_N
77	MCK_P	O	8 mA	DDR2 MCK_P
76	MCK_N	O	8 mA	DDR2 MCK_N
64	MDQM1	O	8 mA	DDR2 MDQM#1
108	MDQM0	O	8 mA	DDR2 MDQM#0
78	MCS	O	8 mA	DDR2 MCS
72	MDQS1	I/O	8 mA	DDR2 MDQS#1
113	MDQS0	I/O	8 mA	DDR2 MDQS#0
103	MCKE	O	8 mA	DDR2 MCKE
63	DDR_IO_VSS_1	G		DDR IO Ground pins
115	DDR_IO_VSS_2			
79	DDR_IO_1V8D_1	P		
98	DDR_IO_1V8D_2			
116	DDR_IO_1V8D_3			
90	DDR_IO_VREF_1	A		DDR reference voltage
104	DDR_IO_VREF_2			
DDR1				
64	MD15	I/O	8 mA	DDR1 Data bit #15
65	MD14	I/O	8 mA	DDR1 Data bit #14
66	MD13	I/O	8 mA	DDR1 Data bit #13
67	MD12	I/O	8 mA	DDR1 Data bit #12
68	MD11	I/O	8 mA	DDR1 Data bit #11
69	MD10	I/O	8 mA	DDR1 Data bit #10
70	MD9	I/O	8 mA	DDR1 Data bit #9
71	MD8	I/O	8 mA	DDR1 Data bit #8
106	MD7	I/O	8 mA	DDR1 Data bit #7
107	MD6	I/O	8 mA	DDR1 Data bit #6
108	MD5	I/O	8 mA	DDR1 Data bit #5
109	MD4	I/O	8 mA	DDR1 Data bit #4
110	MD3	I/O	8 mA	DDR1 Data bit #3
111	MD2	I/O	8 mA	DDR1 Data bit #2
112	MD1	I/O	8 mA	DDR1 Data bit #1
114	MD0	I/O	8 mA	DDR1 Data bit #0
88	MA13	O	8 mA	DDR1 Address bit #13
86	MA12	O	8 mA	DDR1 Address bit #12
85	MA11	O	8 mA	DDR1 Address bit #11
99	MA10	O	8 mA	DDR1 Address bit #10
84	MA9	O	8 mA	DDR1 Address bit #9
83	MA8	O	8 mA	DDR1 Address bit #8
82	MA7	O	8 mA	DDR1 Address bit #7
81	MA6	O	8 mA	DDR1 Address bit #6

Pins	Name	Type	Driv.	Description
80	MA5	O	8 mA	DDR1 Address bit #5
74	MA4	O	8 mA	DDR1 Address bit #4
103	MA3	O	8 mA	DDR1 Address bit #3
102	MA2	O	8 mA	DDR1 Address bit #2
101	MA1	O	8 mA	DDR1 Address bit #1
100	MA0	O	8 mA	DDR1 Address bit #0
97	MBA1	O	8 mA	DDR1 MBA #1
96	MBA0	O	8 mA	DDR1 MBA #0
94	MRAS	O	8 mA	DDR1 MRAS_N
93	MCAS	O	8 mA	DDR1 MCAS_N
92	MWE	O	8 mA	DDR1 MWE_N
77	MCK_P	O	8 mA	DDR1 MCK_P
76	MCK_N	O	8 mA	DDR1 MCK_N
73	MDQM1	O	8 mA	DDR1 MDQM#1
105	MDQM0	O	8 mA	DDR1 MDQM#0
95	MCS	O	8 mA	DDR1 MCS
72	MDQS1	I/O	8 mA	DDR1 MDQS#1
113	MDQS0	I/O	8 mA	DDR1 MDQS#0
87	MCKE	O	8 mA	DDR1 MCKE
63 75 78 115	DDR_IO_VSS_1 DDR_IO_VSS_2 DDR_IO_VSS_3 DDR_IO_VSS_4	G		DDR IO Ground pins
79 98 116	DDR_IO_1V8D_1 DDR_IO_1V8D_2 DDR_IO_1V8D_3	P		DDR IO Supply power
90 104	DDR_IO_VREF_1 DDR_IO_VREF_2	A		DDR reference voltage
PMU				
118 119	LXBK_1 LXBK_2	O		Buck Switching node
122	VOUT_FB	A		Buck vout feedback pin
117	AVDD33_SMPS	P		Buck 3.3V Supply power
120 121	AVSS33_SMPS_1 AVSS33_SMPS_2	G		Buck Gound pin
123 124	AVDD33_DDRLDO_1 AVDD33_DDRLDO_2	P		DDRLDO 3.3V Supply power
125	DDRLDO	O		DDRLDO 1.8V/2.5V output voltage
Power				
23 146	SOC_IO_V33D_1 SOC_IO_V33D_2	P		3.3 V digital I/O power supply
22 58 89 91 145	SOC_CO_V12D_1 SOC_CO_V12D_2 SOC_CO_V12D_3 SOC_CO_V12D_4 SOC_CO_V12D_5	P		1.2 V digital core power supply
EPAD	GND	G		Ground pin

Pins	Name	Type	Driv.	Description
------	------	------	-------	-------------

Total: 156 pins

- Note:
- IPD : Internal pull-down
 - IPU : Internal pull-up
 - I : Input
 - O : Output
 - IO : Bi-directional
 - P : Power
 - G : Ground
 - NC : Not connected

3.2 MT7688KN DR-QFN (10 mm x 10 mm) 120-Pin Package Diagram

3.2.1 Left side vie

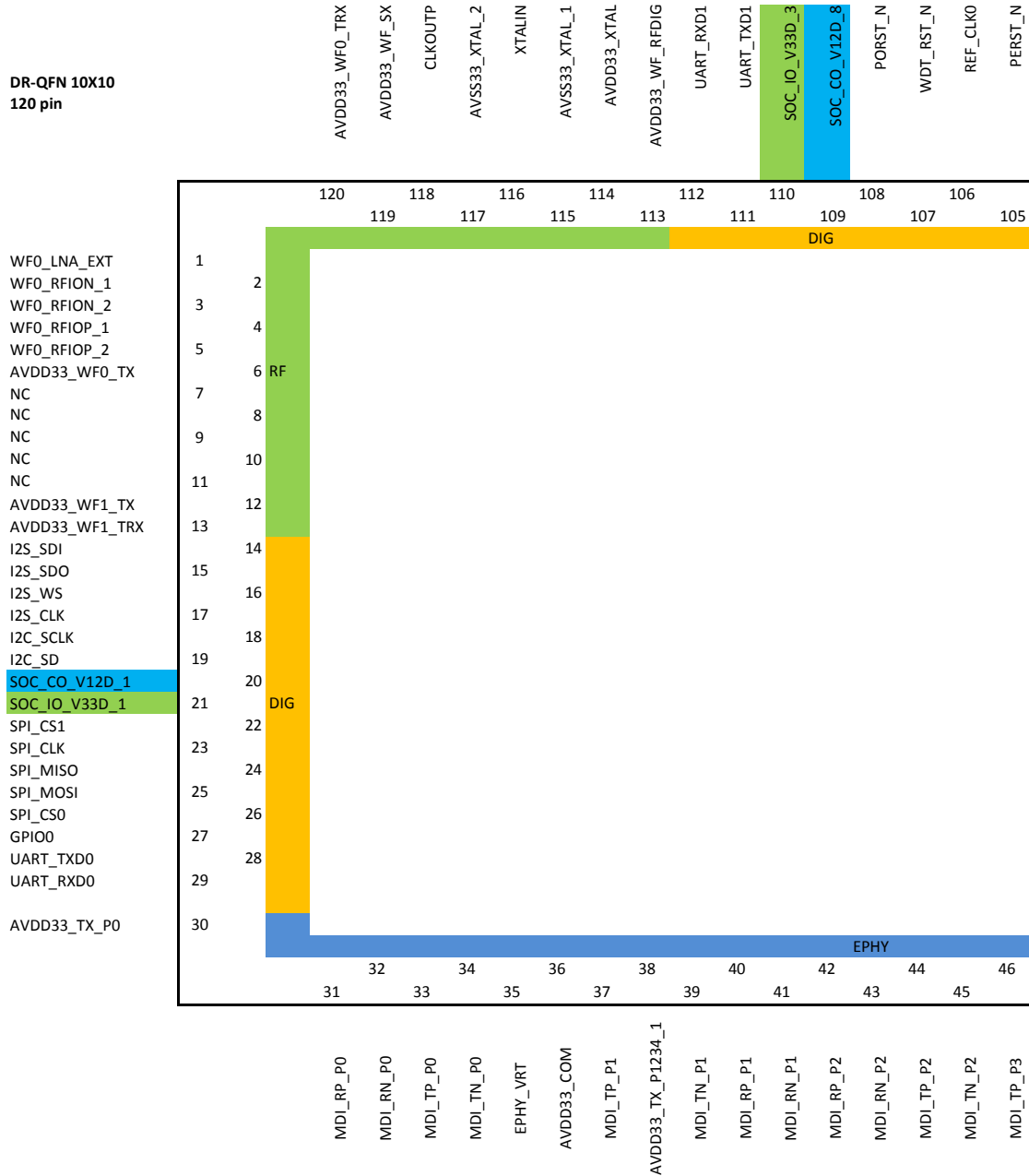

Figure 3-5 MT7688KN DR-QFN Pin Diagram (left view)

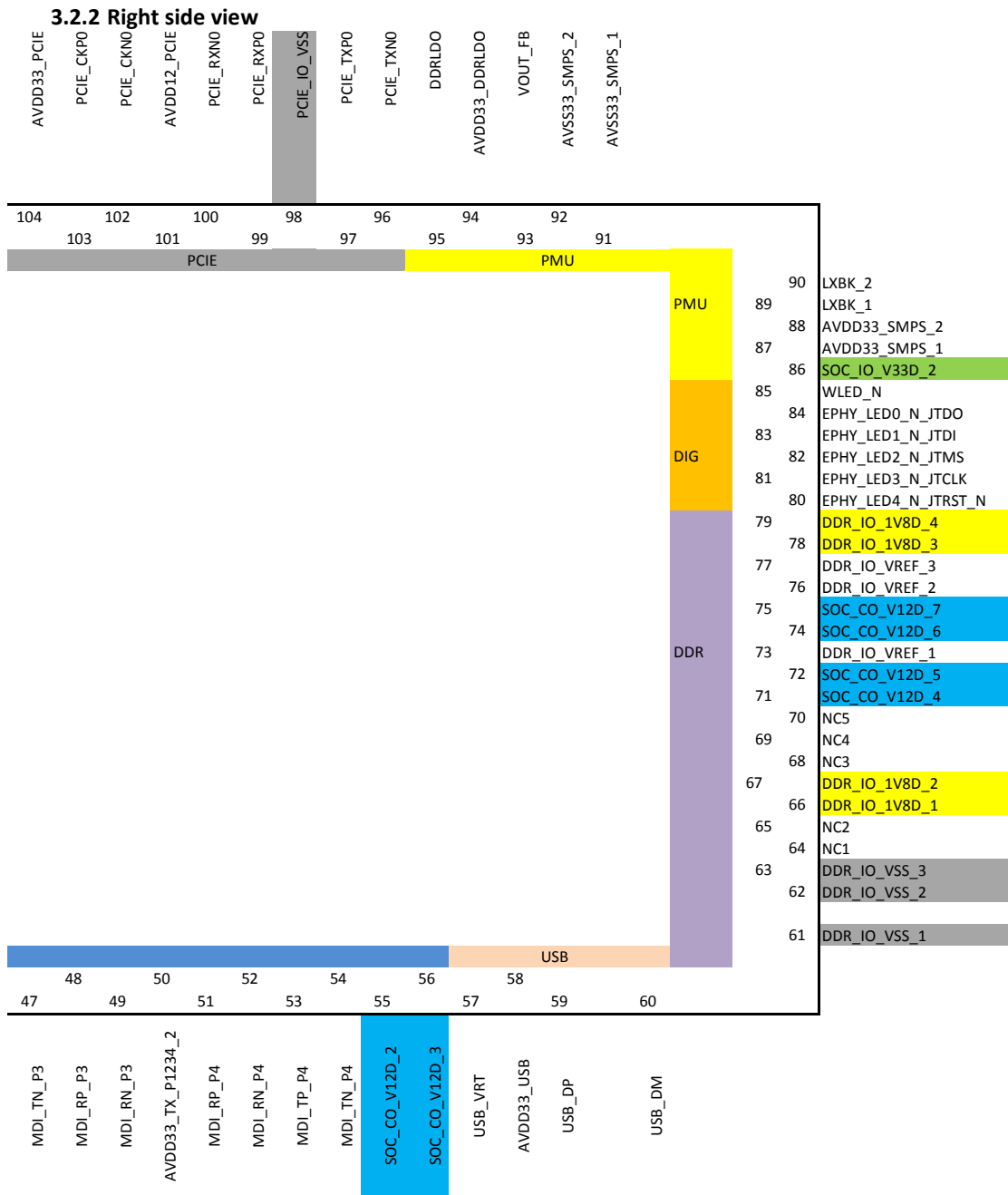

Figure 3-6 MT7688KN DR-QFN Pin Diagram (right side view)

3.2.3 Pin Description

Pins	Name	Type	Driv.	Description
RF				
2	WF0_RFION_1	A		WF0 main path RF I/O
3	WF0_RFION_2			
4	WF0_RFIOP_1	A		WF0 main path RF I/O
5	WF0_RFIOP_2			
8	NC			
9	NC			
10	NC			
11	NC			
7	NC			
1	WF0_LNA_EXT	A		WF0 aux. path LNA input
116	XTALIN	I		Crystal oscillator input
118	CLKOUTP	O		XO reference clock output
114	AVDD33_XTAL	P		3.3V XTAL Power Supply Pin
115	AVS33_XTAL_1	G		3.3V XTAL Ground Pin
117	AVS33_XTAL_2			
6	AVDD33_WF0_TX	P		3.3V RF Channel 0 Supply Power
12	AVDD33_WF1_TX	P		3.3V RF Channel 1 Supply Power
13	AVDD33_WF1_TRX	P		1.65V to 3.3V RF Channel 1 Supply Power
113	AVDD33_WF_RFDIG	P		1.65V to 3.3V RF DIG and AFE Supply Power
119	AVDD33_WF_SX	P		1.65V to 3.3V RF Supply Power
120	AVDD33_WF0_TRX	P		1.65V to 3.3V RF Channel 0 Supply Power
WLAN LED				
85	WLED_N	O	4 mA	WLAN Activity LED
UART0 Lite				
28	TXD0	O, IPD	4 mA	UART0 Lite TXD
29	RXD0	I		UART0 Lite RXD
UART1 Lite				
111	TXD1	O, IPU	4 mA	UART1 Lite TXD
112	RXD1	I		UART1 Lite RXD
I2S				
14	I2S_SDI	I/O	4 mA	I2S data input
15	I2S_SDO	O, IPD	4 mA	I2S data output
16	I2S_WS	I/O	4 mA	I2S word select
17	I2S_CLK	I/O	4 mA	I2S clock
I2C				
19	I2C_SD	I/O	4 mA	I2C Data
18	I2C_SCLK	I/O	4 mA	I2C Clock
SPI				
24	SPI_MISO	I/O	4 mA	SPI Master input/Slave output
25	SPI_MOSI	I/O, IPD	4 mA	SPI Master output/Slave input
23	SPI_CLK	O, IPU	4 mA	SPI clock
26	SPI_CS0	O	4 mA	SPI chip select0

Pins	Name	Type	Driv.	Description
22	SPI_CS1	O, IPD	4 mA	SPI chip select1
GPIO				
27	GPIO0	I/O, IPD	4 mA	General Purpose I/O
5-Port EPHY				
84	EPHY_LED0_N_JTDO	I/O	4 mA	10/100 PHY Port #0 activity LED, JTAG_TDO
83	EPHY_LED1_N_JTDI	I/O	4 mA	10/100 PHY Port #1 activity LED, JTAG_TDI
82	EPHY_LED2_N_JTMS	I/O	4 mA	10/100 PHY Port #2 activity LED, JTAG_TMS
81	EPHY_LED3_N_JTCLK	I/O	4 mA	10/100 PHY Port #3 activity LED, JTAG_CLK
80	EPHY_LED4_N_JTRST_N	I/O,	4 mA	10/100 PHY Port #4 activity LED, JTAG_TRST_N
35	EPHY_VRT	A		Connect to an external resistor to provide accurate bias current
31	MDI_RP_P0	A		10/100 PHY Port #0 RXP
32	MDI_RN_P0	A		10/100 PHY Port #0 RXN
33	MDI_TP_P0	A		10/100 PHY Port #0 TXP
34	MDI_TN_P0	A		10/100 PHY Port #0 TXN
37	MDI_TP_P1	A		General purpose IO (SD-XC, eMMC...etc)
39	MDI_TN_P1	A		General purpose IO (SD-XC, eMMC...etc)
40	MDI_RP_P1	A		General purpose IO (SD-XC, eMMC...etc)
41	MDI_RN_P1	A		General purpose IO (SD-XC, eMMC...etc)
42	MDI_RP_P2	A		General purpose IO (SD-XC, eMMC...etc)
43	MDI_RN_P2	A		General purpose IO (SD-XC, eMMC...etc)
44	MDI_TP_P2	A		General purpose IO (SD-XC, eMMC...etc)
45	MDI_TN_P2	A		General purpose IO (SD-XC, eMMC...etc)
46	MDI_TP_P3	A		General purpose IO (SD-XC, eMMC...etc)
47	MDI_TN_P3	A		General purpose IO (SD-XC, eMMC...etc)
48	MDI_RP_P3	A		General purpose IO (SD-XC, eMMC...etc)
49	MDI_RN_P3	A		General purpose IO (SD-XC, eMMC...etc)
51	MDI_RP_P4	A		General purpose IO (SD-XC, eMMC...etc)
52	MDI_RN_P4	A		General purpose IO (SD-XC, eMMC...etc)
53	MDI_TP_P4	A		General purpose IO (SD-XC, eMMC...etc)
54	MDI_TN_P4	A		General purpose IO (SD-XC, eMMC...etc)
30	AVDD33_TX_P0	P		3.3V Supply Power for P0
36	AVDD33_COM	P		3.3V Supply Power for EPHY COM
38	AVDD33_TX_P1234_1	P		3.3V Supply Power for P1 ~ P4
50	AVDD33_TX_P1234_2			
Misc.				
106	REF_CLKO	O, IPD	4 mA	Reference Clock Ouptut
108	PORST_N	I		Power on reset
107	WDT_RST_N	O	4 mA	Watchdog Reset
USB PHY				
58	AVDD33_USB	P		3.3 V USB PHY analog power supply
57	USB_VRT	A		Connect to an external 5.1 kΩ resistor for band-gap reference circuit

Pins	Name	Type	Driv.	Description
60	USB_DM	I/O		USB Port0 data pin Data-
59	USB_DP	I/O		USB Port0 data pin Data+
PCIe PHY				
105	PERST_N	O, IPD	4mA	PCIe device reset
98	PCIE_IO_VSS	G		PCIe Ground pin
101	AVDD12_PCIE	P		1.2 V PCIe PHY digital power supply
104	AVDD33_PCIE	P		3.3 V PCIe PHY analog power supply
103	PCIE_CKPO	O		External reference clock output (positive)
102	PCIE_CKN0	O		External reference clock output (negative)
97	PCIE_TXP0	I/O		PCIe0 differential transmit TX +
96	PCIE_TXN0	I/O		PCIe0 differential transmit TX -
99	PCIE_RXP0	I/O		PCIe0 differential receiver RX +
100	PCIE_RXN0	I/O		PCIe0 differential receiver RX -
PMU				
89	LXBK_1	O		Buck Switching node
90	LXBK_2			
93	VOUT_FB	A		Buck vout feedback pin
87	AVDD33_SMPS_1	P		Buck 3.3V Supply power
88	AVDD33_SMPS_2			
91	AVSS33_SMPS_1	G		Buck Gound pin
92	AVSS33_SMPS_2			
94	AVDD33_DDRLDO	P		DDRLDO 3.3V Supply power
95	DDRLDO	O		DDRLDO 1.8V/2.5V output voltage
Power/Ground				
21	SOC_IO_V33D_1	P		3.3 V digital I/O power supply
86	SOC_IO_V33D_2			
110	SOC_IO_V33D_3			
61	DDR_IO_VSS_1	G		DDR IO Ground pins
62	DDR_IO_VSS_2	G		
63	DDR_IO_VSS_3	G		
66	DDR_IO_1V8D_1	P		DDR IO 1.8V Supply power
67	DDR_IO_1V8D_2	P		
78	DDR_IO_1V8D_3	P		
79	DDR_IO_1V8D_4	P		
73	DDR_IO_VREF_1	A		DDR reference voltage
76	DDR_IO_VREF_2	A		
77	DDR_IO_VREF_3	A		
20	SOC_CO_V12D_1	P		1.2 V digital core power supply
55	SOC_CO_V12D_2			
56	SOC_CO_V12D_3			
71	SOC_CO_V12D_4			
72	SOC_CO_V12D_5			
74	SOC_CO_V12D_6			
75	SOC_CO_V12D_7			
109	SOC_CO_V12D_8			
EPAD	GND	G		Ground pin
NC				

Pins	Name	Type	Driv.	Description
64	NC_1	NC		No connected
65	NC_2			
68	NC_3			
69	NC_4			
70	NC_5			

Total: 120 pins

Note:

- IPD : Internal pull-down
- IPU : Internal pull-up
- I : Input
- O : Output
- IO : Bi-directional
- P : Power
- G : Ground
- NC : Not connected

3.3 Pin Sharing Schemes

Some pins are shared with GPIO to provide maximum flexibility for system designers. The MT7688 provides up to 41 GPIO pins. Users can configure GPIO1_MODE and GPIO2_MODE registers in the System Control block to specify the pin function, or they can use the registers specified below. For more information, see the Programmer's Guide. Unless specified explicitly, all the GPIO pins are in input mode after reset.

3.3.1 GPIO pin share scheme

I/O Pad Group	Normal Mode	GPIO Mode
UART1	UART_RXD1	GPIO#46
	UART_TXD1	GPIO#45
WLED_AN	WLED_N (7688AN)	GPIO#44
P0_LED_AN	EPHY_LED0_N_JTDO (7688AN)	GPIO#43
P1_LED_AN	EPHY_LED1_N_JTDI (7688AN)	GPIO#42
P2_LED_AN	EPHY_LED2_N_JTMS (7688AN)	GPIO#41
P3_LED_AN	EPHY_LED3_N_JTCLK (7688AN)	GPIO#40
P4_LED_AN	EPHY_LED4_N_JTRST_N (7688AN)	GPO#39
WDT	WDT_RST_N	GPO#38
REFCLK	REF_CLKO	GPIO#37
PERST	PERST_N	GPIO#36
WLED_KN	WLED_N (7688KN)	GPIO#35
P0_LED_KN	EPHY_LED0_N_JTDO (7688KN)	GPIO#34
P1_LED_KN	EPHY_LED1_N_JTDI (7688KN)	GPIO#33
P2_LED_KN	EPHY_LED2_N_JTMS (7688KN)	GPIO#32
P3_LED_KN	EPHY_LED3_N_JTCLK (7688KN)	GPIO#31
P4_LED_KN	EPHY_LED4_N_JTRST_N (7688KN)	GPIO#30
SD / eMMC	MDI_TN_P4	GPIO#29
	MDI_TP_P4	GPIO#28
	MDI_RN_P4	GPIO#27
	MDI_RP_P4	GPIO#26
	MDI_RN_P3	GPIO#25
	MDI_RP_P3	GPIO#24
	MDI_TN_P3	GPIO#23

I/O Pad Group	Normal Mode	GPIO Mode
	MDI_TP_P3	GPIO#22
UART2 / eMMC	MDI_TN_P2	GPIO#21
	MDI_TP_P2	GPIO#20
PWM1 / eMMC	MDI_RN_P2	GPO#19
PWM0 / eMMC	MDI_RP_P2	GPO#18
SPIS	MDI_RN_P1	GPIO#17
	MDI_RP_P1	GPIO#16
	MDI_TN_P1	GPO#15
	MDI_TP_P1	GPIO#14
UART0	UART_RXD0	GPIO#13
	UART_TXD0	GPIO#12
GPIO	GPIO0	GPIO#11
SPI	SPI_CS0	GPIO#10
	SPI_MISO	GPIO#9
	SPI_MOSI	GPIO#8
	SPI_CLK	GPIO#7
SPI_CS1	SPI_CS1	GPIO#6
I2C	I2C_SD	GPO#5
	I2C_SCLK	GPO#4
I2S	I2S_CLK	GPIO#3
	I2S_WS	GPIO#2
	I2S_SDO	GPIO#1
	I2S_SDI	GPO#0

3.3.2 UART1 pin share scheme

Controlled by the UART1_MODE register.

Pin Name	2'b00 UART-Lite #1	2'b01 GPIO	2'b10 PWM	2'b11 TRX_SW
UART1_RXD	UART1_RXD	GPIO#46	PWM_CH1	
UART1_TXD	UART1_TXD	GPIO#45	PWM_CH0	

3.3.3 MT7688AN EPHY LED pin share scheme

Controlled by the P#_LED_AN_MODE registers

Pin Name	Bootstrapping (DBG_JTAG_MODE=1)	Bootstrapping (DBG_JTAG_MODE=0)	
		P4_LED_AN_MODE =2'b00	P4_LED_AN_MODE =2'b01
EPHY_LED4_N_JTRST_N	JTAG_RST_N	EPHY_LED4_N	GPIO#39
		P3_LED_AN_MODE =2'b00	P3_LED_AN_MODE =2'b01
EPHY_LED3_N_JTCLK	JTAG_CLK	EPHY_LED3_N	GPIO#40
		P2_LED_AN_MODE =2'b00	P2_LED_AN_MODE =2'b01
EPHY_LED2_N_JTMS	JTAG_TMS	EPHY_LED2_N	GPIO#41

		P1_LED_AN_MODE =2'b00	P1_LED_AN_MODE =2'b01
EPHY_LED1_N_JTDI	JTAG_TDI	EPHY_LED1_N	GPIO#42
		P0_LED_AN_MODE =2'b00	P0_LED_AN_MODE =2'b01
EPHY_LED0_N_JTDO	JTAG_TDO	EPHY_LED0_N	GPIO#43

3.3.4 MT7688AN WLAN LED pin share scheme

Controlled by the WLED_AN_MODE registers

Pin Name	2'b00	2'b01
WLED_N	WLED_N	GPIO#44

3.3.5 MT7688KN EPHY LED pin share scheme

Controlled by the P#_LED_KN_MODE registers

Pin Name	Bootstrapping (DBG_JTAG_MODE=1)	Bootstrapping (DBG_JTAG_MODE=0)	
		P4_LED_KN_MODE =2'b00	P4_LED_KN_MODE =2'b01
EPHY_LED4_N_JTRST_N	JTAG_RST_N	EPHY_LED4_N	GPIO#30
		P3_LED_KN_MODE =2'b00	P3_LED_KN_MODE =2'b01
EPHY_LED3_N_JTCLK	JTAG_CLK	EPHY_LED3_N	GPIO#31
		P2_LED_KN_MODE =2'b00	P2_LED_KN_MODE =2'b01
EPHY_LED2_N_JTMS	JTAG_TMS	EPHY_LED2_N	GPIO#32
		P1_LED_KN_MODE =2'b00	P1_LED_KN_MODE =2'b01
EPHY_LED1_N_JTDI	JTAG_TDI	EPHY_LED1_N	GPIO#33
		P0_LED_KN_MODE =2'b00	P0_LED_KN_MODE =2'b01
EPHY_LED0_N_JTDO	JTAG_TDO	EPHY_LED0_N	GPIO#34

3.3.6 MT7688KN WLAN LED pin share scheme

Controlled by the WLED_KN_MODE registers

Pin Name	2'b00	2'b01
WLED_N	WLED_N	GPIO#35

3.3.7 PERST_N pin share scheme

Controlled by the PERST_MODE register.

Pin Name	1'b0	1'b1
PERST_N	PERST_N	GPIO#36

3.3.8 WDT_RST_N pin share scheme

Controlled by the WDT_MODE register.

Pin Name	1'b0	1'b1
WDT_RST_N	WDT_RST_N	GPIO#38

3.3.9 REF_CLKO pin share scheme

Controlled by the REFCLK_MODE register.

Pin Name	1'b0	1'b1
REF_CLKO	REF_CLKO	GPIO#37

3.3.10 UART0 pin share scheme

Controlled by the UART0_MODE register.

Pin Name	1'b0	1'b1
UART_TXD0	UART_TXD0	GPIO#12
UART_TXD0	UART_RXD0	GPIO#13

3.3.11 GPIO0 pin share scheme

Controlled by GPIO_MODE register.

Pin Name	2'b00	2'b01	2'b10	2'b11
GPIO0	GPIO#11	GPIO#11	REF_CLKO	PERST_N

3.3.12 SPI pin share scheme

Controlled by SPI_MODE register.

Pin Name	1'b0	1'b1
SPI_CLK	SPI_CLK	GPO#7
SPI_MOSI	SPI_MOSI	GPO#8
SPI_MISO	SPI_MISO	GPIO#9
SPI_CS0	SPI_CS0	GPIO#10

3.3.13 SPI_CS1 pin share scheme

Controlled by SPI_CS1_MODE register.

Pin Name	2'b00	2'b01	2'b10
SPI_CS1	SPI_CS1	GPIO#6	REF_CLKO

3.3.14 I2C pin share scheme

Controlled by I2C_MODE register.

Pin Name	2'b00	2'b01
I2C_SCLK	I2C_SCLK	GPIO#4
I2C_SD	I2C_SD	GPIO#5

3.3.15 I2S pin share scheme

Controlled by I2S_MODE register.

Pin Name	2'b00	2'b01	2'b10
I2S_SDI	I2S_SDI	GPIO#0	PCMDRX
I2S_SDO	I2S_SDO	GPIO#1	PCMDTX
I2S_WS	I2S_WS	GPIO#2	PCMCLK
I2S_CLK	I2S_CLK	GPIO#3	PCMFS

3.3.16 SD pin share scheme

Controlled by the EPHY_APGIO_AIO_EN[4:1] and SD_MODE registers

Pin Name	EPHY_APGIO_AIO_EN[4:1] =4'b0000	EPHY_APGIO_AIO_EN[4:1] =4'b1111	
		SD_MODE =2'b00	SD_MODE =2'b01
MDI_TP_P3	MDI_TP_P3	SD_WP	GPIO#22
MDI_TN_P3	MDI_TN_P3	SD_CD	GPIO#23
MDI_RP_P3	MDI_RP_P3	SD_D1	GPIO#24
MDI_RN_P3	MDI_RN_P3	SD_D0	GPIO#25
MDI_RP_P4	MDI_RP_P4	SD_CLK	GPIO#26
MDI_RN_P4	MDI_RN_P4	SD_CMD	GPIO#27
MDI_TP_P4	MDI_TP_P4	SD_D3	GPIO#28
MDI_TN_P4	MDI_TN_P4	SD_D2	GPIO#29

3.3.17 eMMC pin share scheme

Controlled by the EPHY_APGIO_AIO_EN[4:1] and SD_MODE registers

Pin Name	EPHY_APGIO_AIO_EN[4:1] =4'b0000	EPHY_APGIO_AIO_EN[4:1] =4'b1111	
		SD_MODE =2'b00	SD_MODE =2'b01
MDI_TP_P3	MDI_TP_P3	eMMC_WP	GPIO#22
MDI_TN_P3	MDI_TN_P3	eMMC_CD	GPIO#23
MDI_RP_P3	MDI_RP_P3	eMMC_D1	GPIO#24
MDI_RN_P3	MDI_RN_P3	eMMC_D0	GPIO#25
MDI_RP_P4	MDI_RP_P4	eMMC_CLK	GPIO#26
MDI_RN_P4	MDI_RN_P4	eMMC_CMD	GPIO#27
MDI_TP_P4	MDI_TP_P4	eMMC_D3	GPIO#28
MDI_TN_P4	MDI_TN_P4	eMMC_D2	GPIO#29

3.3.18 UART2 pin share scheme

Controlled by the EPHY_APGIO_AIO_EN[4:1] and UART2_MODE registers

Pin Name	4'b0000	4'b1111			
		2'b00	2'b01	2'b10	2'b11
MDI_TP_P2	MDI_TP_P2	UART_TXD2	GPIO#20	PWM_CH2	eMMC_D5
MDI_TN_P2	MDI_TN_P2	UART_RXD2	GPIO#21	PWM_CH3	eMMC_D4

3.3.19 PWM_CH0 pin share scheme

Controlled by the EPHY_APGIO_AIO_EN[4:1] and PWM0_MODE registers

Pin Name	4'b0000	4'b1111			
		2'b00	2'b01	2'b10	2'b11
MDI_RP_P2	MDI_RP_P2	PWM_CH0	GPIO#18		eMMC_D7

3.3.20 PWM_CH1 pin share scheme

Controlled by the EPHY_APGIO_AIO_EN[4:1] and PWM1_MODE registers

	4'b0000	4'b1111

Pin Name		2'b00	2'b01	2'b10	2'b11
MDI_RN_P2	MDI_RN_P2	PWM_CH1	GPIO#19		eMMC_D6

3.3.21 SPIS pin share scheme

Controlled by the EPHY_APGIO_AIO_EN[4:1] and SPIS_MODE registers

	4'b0000	4'b1111			
Pin Name		2'b00	2'b01	2'b10	2'b11
MDI_TP_P1	MDI_TP_P1	SPIS_CS	GPIO#14		PWM_CH0
MDI_TN_P1	MDI_TN_P1	SPIS_CLK	GPIO#15		PWM_CH1
MDI_RP_P1	MDI_RP_P1	SPIS_MISO	GPIO#16		UART_TXD2
MDI_RN_P1	MDI_RN_P1	SPIS_MOSI	GPIO#17		UART_RXD2

3.3.22 Pin share function description

Pin Share Name	I/O	Pin Share Function description
PCMDTX	O	PCM Data Transmit DATA signal sent from the PCM host to the external codec.
PCMDRX	I	PCM Data Receive DATA signal sent from the external codec to the PCM host.
PCMCLK	I/O	PCM Clock The clock signal can be generated by the PCM host (Output direction), or provided by an external clock (input direction). The clock frequency should match the slot configuration of the PCM host. e.g. 4 slots, PCM clock out/in should be 256 kHz. 8 slots, PCM clock out/in should be 512 kHz. 16 slots, PCM clock out/in should be 1.024 MHz. 32 slots, PCM clock out/in should be 2.048 MHz. 64 slots, PCM clock out/in should be 4.096 MHz. 128 slots, PCM clock out/in should be 8.192 MHz.
PCMFS	I/O	PCM SYNC signal. In our design, the direction of this signal is independent of the direction of PCMCLK. Its direction and mode is configurable.
PWM_CH0	O	Pulse Width Modulation Channle 0
PWM_CH1	O	Pulse Width Modulation Channle 1
PWM_CH2	O	Pulse Width Modulation Channle 2
PWM_CH3	O	Pulse Width Modulation Channle 3

3.4 Bootstrapping Pins Description

Pin Name	Boot Strapping Signal Name	Description
UART_TXD1	DBG_JTAG_MODE	0: JTAG_MODE 1: EPHY_LED (default)
PERST_N	XTAL_FREQ_SEL	0: 25 MHz DIP 1: 40 MHz SMD
I2S_SDO	DRAM_TYPE	1: DDR1 0: DDR2 [note] This pin is valid for MT7688AN only. It needs to be pull-low for 7688KN which only supports DDR1.

Pin Name	Boot Strapping Signal Name	Description
{SPI_MOSI SPI_CLK, SPI_CS1}	CHIP_MODE[2:0]	A vector to set chip function/test/debug modes. 000: Boot from PLL (boot from SPI 3-Byte Addr) 001: Boot from PLL (boot from SPI 4-Byte Addr) 010: Boot from XTAL (boot from SPI 3-Byte Addr) 011: Boot from XTAL (boot from SPI 4-Byte Addr)
PAD_TXDO	EXT_BGCK	1: Test Mode 0: Normal (default)

4. Maximum Ratings and Operating Conditions

4.1 Absolute Maximum Ratings

I/O supply voltage	3.63 V
Input, Output, or I/O Voltage	GND -0.3 V to Vcc +0.3 V

Table 4-1 Absolute Maximum Ratings

4.2 Maximum Temperatures

Maximum Junction Temperature (Plastic Package)	125 °C
Maximum Lead Temperature (Soldering 10 s)	260 °C

Table 4-2 Maximum Temperatures

4.3 Operating Conditions

I/O supply voltage	3.3 V +/- 10%
DDR1 supply voltage	2.5 V +/- 5%
DDR2 supply voltage	1.8 V +/- 5%
Core supply voltage	1.2 V +/- 10%
Ambient Temperature Range	-20 to 55 °C

Table 4-3 Operating Conditions

4.4 Thermal Characteristics

Thermal characteristics without an external heat sink in still air conditions.

MT7688KN:

Thermal Resistance θ_{JA} (°C /W) for JEDEC 2L system PCB	26.1°C/W
Thermal Resistance θ_{JA} (°C /W) for JEDEC 4L system PCB	17.72°C/W
Thermal Resistance θ_{JC} (°C /W) for JEDEC	6.5°C/W
Thermal Resistance ψ_{jt} (°C /W) for JEDEC 2L system PCB	1.81°C/W
Thermal Resistance ψ_{jt} (°C /W) for JEDEC 4L system PCB	1.18°C/W

MT7688AN:

Thermal Resistance θ_{JA} (°C /W) for JEDEC 2L system PCB	27.01°C/W
Thermal Resistance θ_{JA} (°C /W) for JEDEC 4L system PCB	18.15°C/W
Thermal Resistance θ_{JC} (°C /W) for JEDEC	6.9°C/W
Thermal Resistance ψ_{jt} (°C /W) for JEDEC 2L system PCB	2.41 °C/W
Thermal Resistance ψ_{jt} (°C /W) for JEDEC 4L system PCB	1.51 °C/W

Table 4-4 Thermal Characteristics

4.5 Storage Conditions

The calculated shelf life in a sealed bag is 12 months if stored between 0 °C and 40 °C at less than 90% relative humidity (RH). After the bag is opened, devices that are subjected to solder reflow or other high temperature processes must be handled in the following manner:

- Mounted within 168 hours of factory conditions, i.e. < 30 °C at 60% RH.
- Storage humidity needs to maintained at < 10% RH.

- Baking is necessary if the customer exposes the component to air for over 168 hrs, baking conditions: 125 °C for 8 hrs.

4.6 External Xtal Specification

Frequency	25 MHz/ 40 Mhz
Frequency offset	+/-20 ppm
VIH/VIL	Vcc-0.3 V/0.3 V
Duty cycle	45% to 55%

Table 4-5 External Xtal Specifications

4.7 DC Electrical Characteristics

Parameters	Sym	Conditions	Min	Typ	Max	Unit
3.3 V supply voltage (IO)	Vddc33		2.97	3.3	3.63	V
2.5V supply voltage (DDR1)	Vdd25		2.375	2.5	2.625	V
1.8 V supply voltage (DDR2)	Vdd18		1.71	1.8	1.89	V
1.2 V supply voltage	Vdd12		1.08	1.2	1.32	V
3.3 V current consumption	Icc33					mA
1.5 V current consumption	Icc15					mA
1.2 V current consumption	Icc12					mA
DDR2 Current	Icc18					mA

Table 4-6 DC Electrical Characteristics

Vdd=2.5V (DDR2)	Min	Typ	Max
Vdd	2.375	2.5	2.625
VIH	VREF+0.15		Vdd25+0.3
VIL	-0.3		VREF-0.15
VOH	0.8*Vdd25		
VOL			0.2*Vdd25
IOL			
IOH			

Table 4-7 Vdd 2.5V Electrical Characteristics

Vdd=1.8V (DDR2)	Min	Typ	Max
Vdd	1.71	1.8	1.89
VIH	VREF+0.125		Vdd18+0.3
VIL	-0.3		VREF-0.125
VOH	1.42		
VOL			0.28
IOL			
IOH			

Table 4-8 Vdd 1.8V Electrical Characteristics

Vdd=3.3V	Min	Typ	Max
Vdd	2.97V	3.3V	3.63V
VIH	2.0V		Vdd33+0.3
VIL	-0.3		0.8V
VOH	2.4V		
VOL			0.4V
IOL			
IOH			

Table 4-9 Vdd 3.3V Electrical Characteristics

4.8 AC Electrical Characteristics

4.8.1 DDR2 SDRAM Interface

The DDR2 SDRAM interface complies with 200 MHz timing requirements for standard DDR2 SDRAM. The interface drivers are SSTL_18 drivers matching the EIA/JEDEC standard JESD8-15A.

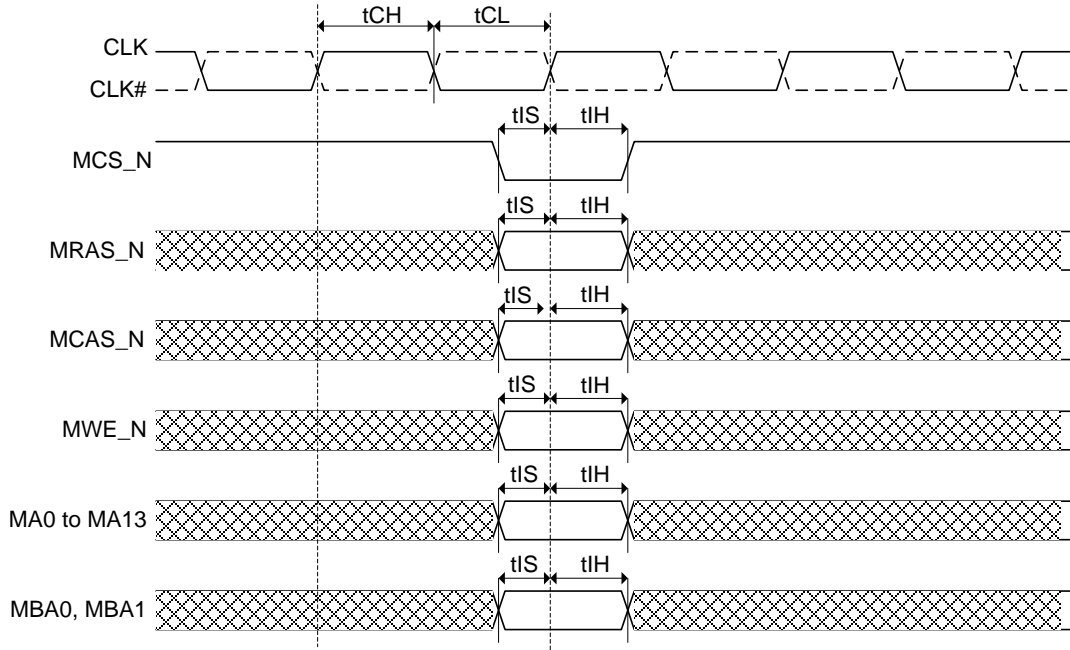

Figure 4-1 DDR2 SDRAM Command

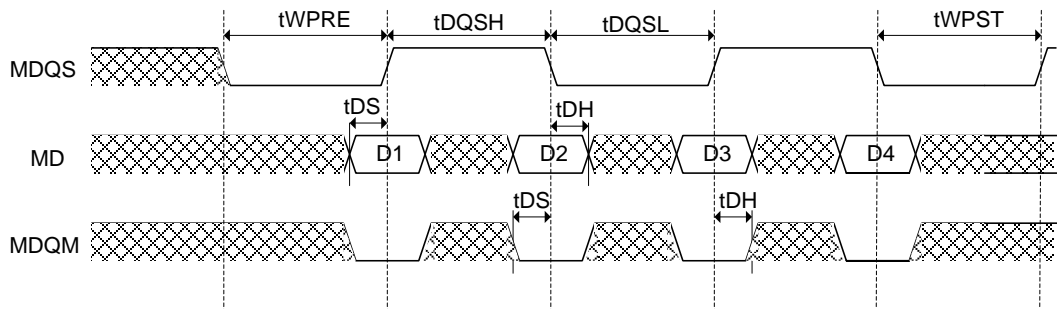

Figure 4-2 DDR2 SDRAM Write data

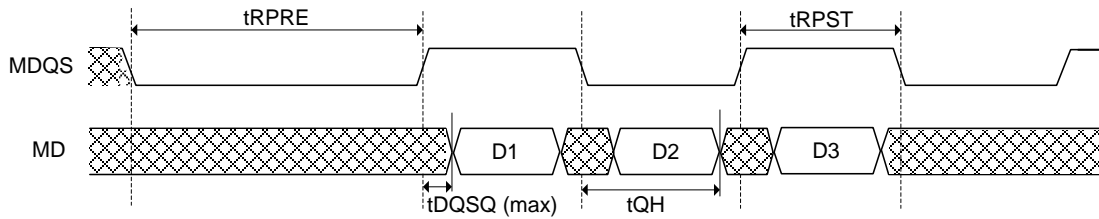

Figure 4-3 DDR2 SDRAM Read data

Symbol	Description	Min	Max	Unit	Remark
tCK(avg)	Clock cycle time	5	-	ns	
tAC	DQ output access time from SDRAM CLK	-0.6	0.6	ns	
tDQSK	DQS output access time from SDRAM CLK	-0.5	0.5	ns	
tCH	SDRAM CLK high pulse width	0.48	0.52	tCK(avg)	

Symbol	Description	Min	Max	Unit	Remark
tCL	SDRAM CLK low pulse width	0.48	0.52	tCK(avg)	
tHP	SDRAM CLK half period	Min(tCH,tCL)	-	ns	
tIS	Address and control input setup time	0.75	-	ns	
tIH	Address and control input hold time	0.75	-	ns	
tDQSQ	Data skew of DQS and associated DQ	-	0.4	ns	
tQH	DQ/DQS output hold time from DQS	tHP-0.5	-	ns	
tRPRE	DQS read preamble	0.9	1.1	tCK	
tRPST	DQS read postamble	0.4	0.6	tCK	
tDQSS	DQS rising edge to CK rising edge	-0.25	0.25	tCK	
tDQSH	DQS input-high pulse width	0.35	-	tCK	
tDQSL	DQS input-low pulse width	0.35	-	tCK	
tDSS	DQS falling edge to SDRAM CLK setup time	0.2	-	tCK	
tDSH	DQS falling edge hold time from SDRAM CLK	0.2	-	tCK	
tWPRE	DQS write preamble	0.35	-	tCK	
tWPST	DQS write postamble	0.4	0.6	tCK	
tDS	DQ and DQM input setup time	*0.4	-	ns	
tDH	DQ and DQM input hold time	*0.4	-	ns	

Table 4-10 DDR2 SDRAM Interface Diagram Key

NOTE: Depends on slew rate of DQS and DQ/DQM for single ended DQS.

4.8.2 SPI Interface

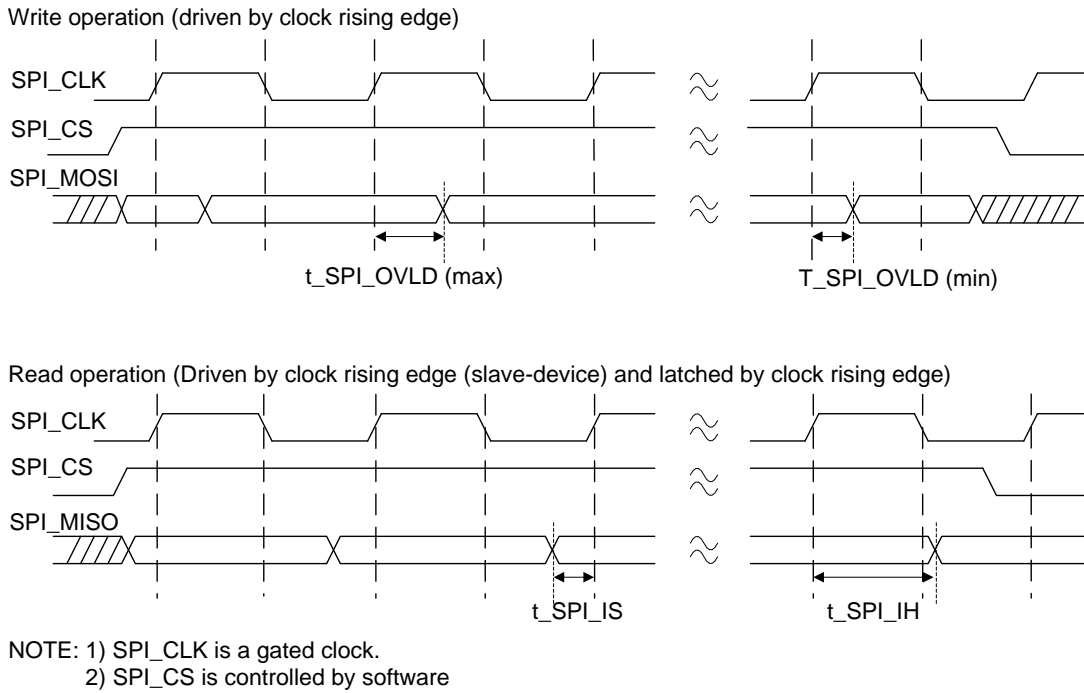

Figure 4-4 SPI Interface

Symbol	Description	Min	Max	Unit	Remark
t_SPI_IS	Setup time for SPI input	6.0	-	ns	
t_SPI_IH	Hold time for SPI input	-1.0	-	ns	
t_SPI_OVLD	SPI_CLK to SPI output valid	-2.0	3.0	ns	output load: 5 pF

Table 4-11 SPI Interface Diagram Key

4.8.3 I²S Interface

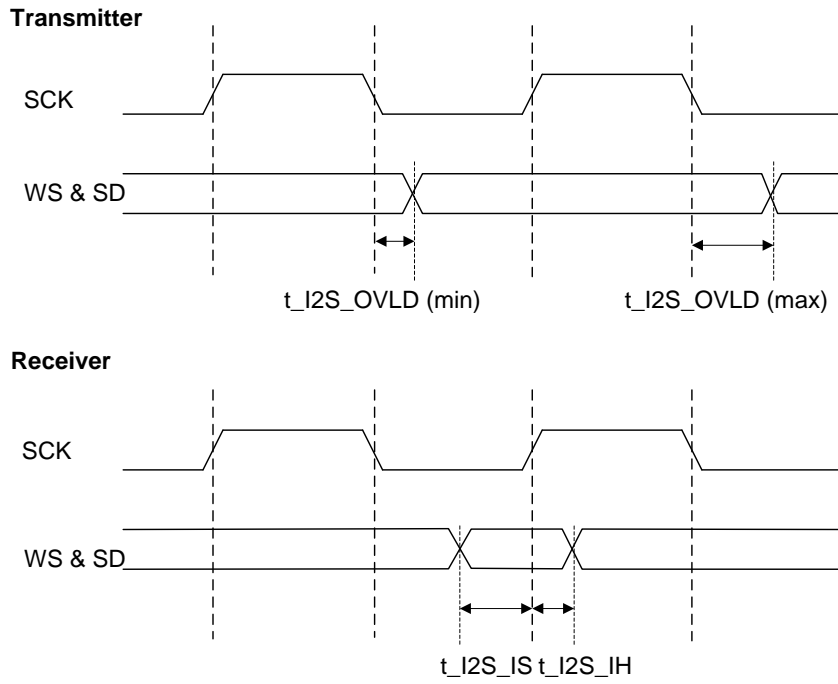

Figure-4-5 I2S Interface

Symbol	Description	Min	Max	Unit	Remark
t_I2S_IS	Setup time for I2S input (data & WS)	3.5	-	ns	
t_I2S_IH	Hold time for I2S input (data & WS)	0.5	-	ns	
t_I2S_OVLD	I2S_CLK to I2S output (data & WS) valid	2.5	10.0	ns	output load: 5 pF

Table 4-12 I2S Interface Diagram Key

4.8.4 PCM Interface

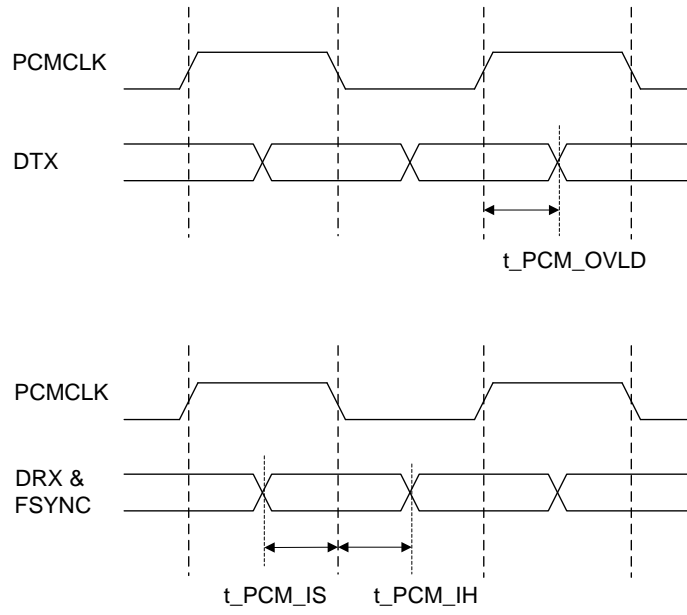

Figure 4-6 PCM Interface

Symbol	Description	Min	Max	Unit	Remark
t_{PCM_IS}	Setup time for PCM input to PCM_CLK fall	3.0	-	ns	
t_{PCM_IH}	Hold time for PCM input to PCM_CLK fall	1.0	-	ns	
t_{PCM_OVLD}	PCM_CLK rise to PCM output valid	10.0	35.0	ns	output load: 5 pF

Table 4-13 PCM Interface Diagram Key

4.8.5 Power On Sequence

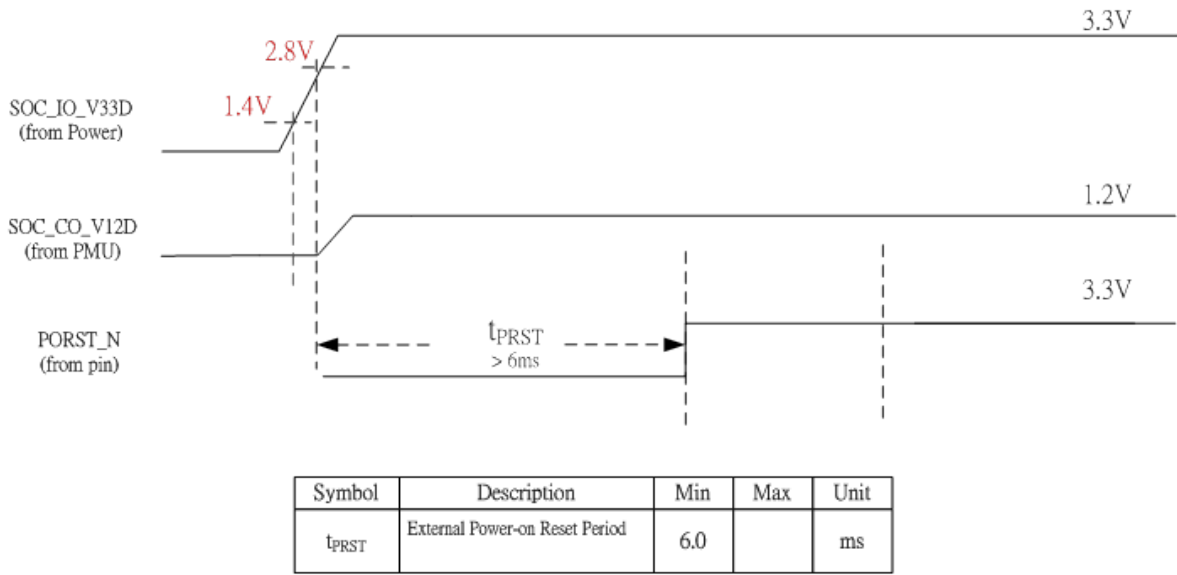

Figure 4-7 Power ON Sequence

Table 4-14 Power ON Sequence Diagram Key

4.9 Package Physical Dimensions

4.9.1 DR-QFN (10 mm x 10 mm) 128 pins

4.9.1.1 Top View

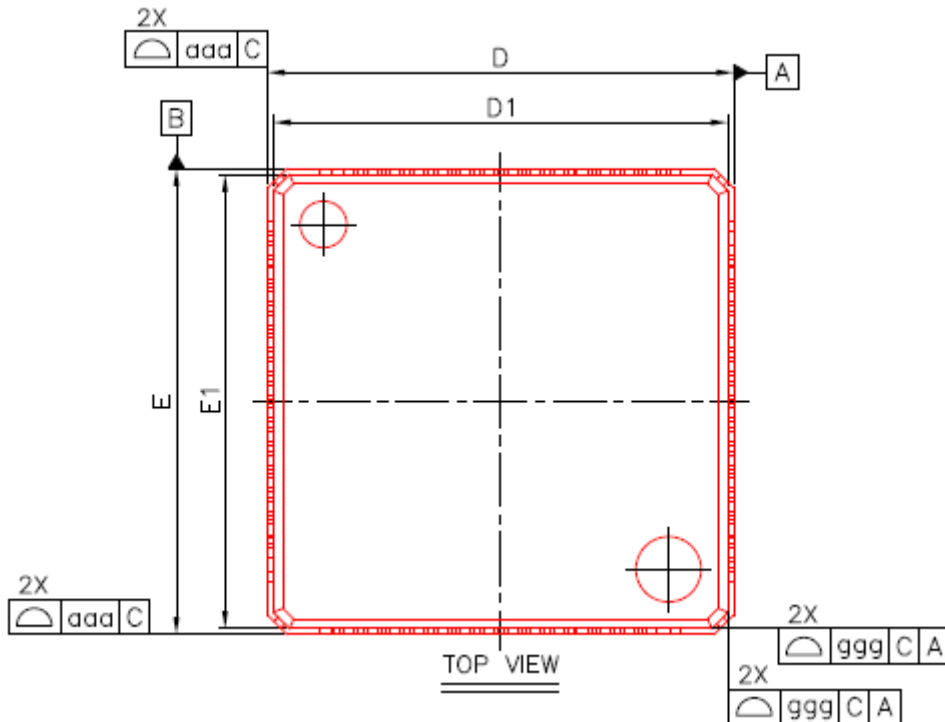

Figure 4-8 Top View

4.9.1.2 Side View

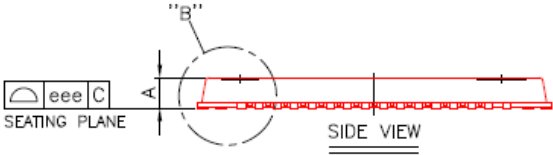

Figure 4-9 Side View

4.9.1.3 "B" Expanded

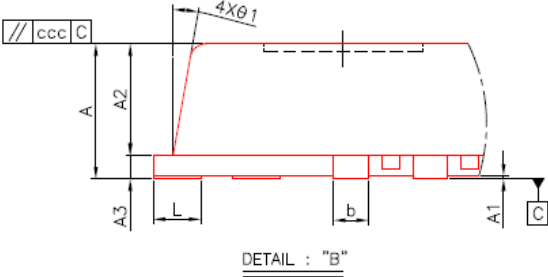

Figure 4-10 "B" Expanded

4.9.1.4 Bottom View

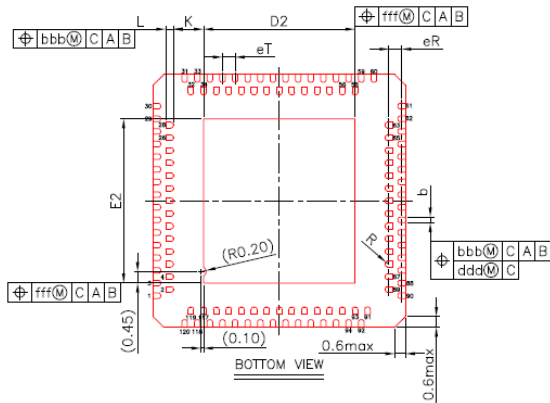

Figure 4-11 Bottom view

4.9.1.5 Package Diagram Key

Item	SYMBOL	MIN.	NOM.	MAX.
TOTAL THICKNESS	A	0.80	0.85	0.90
LEAD STAND OFF.	A1	0.00	0.02	0.05
MOLD THICKNESS	A2	0.65	0.70	0.75
L/F THICKNESS	A3	0.15 REF.		
LEAD WIDTH	b	0.18	0.22	0.30
PACKAGE SIZE	D	9.90	10.00	10.10
	E			
Mold Edge size	D1	9.75 BSC		
	E1	9.75 BSC		
E-PAD size	D2	5.90	6.00	6.10
	E2	6.40	6.50	6.60
LEAD LENGTH	L	0.20	0.30	0.40
LEAD PITCH (BSC.)	eT	0.50 BSC		
LEAD PITCH (BSC.)	eR	0.50 BSC		
ANGLE	θ1	5°	---	15°
LEAD ARC	R	0.09	---	0.14
Lead to E-PAD Tolerance	K	0.20	---	---
PKG EDGE TOLERANCE	aaa	0.10		
PACKAGE PROFILE OF A SURFACE	bbb	0.10		
LEAD PROFILE OF A SURFACE	ccc	0.10		
LEAD POSITION	ddd	0.05		
LEAD PROFILE OF A SURFACE	eee	0.08		
EPAD POSTION	fff	0.10		
Mold edge OF A & C SURFACE	ggg	0.20		

4.9.2 DR-QFN (12 mm x 12 mm) 156 pins

4.9.2.1 Top View

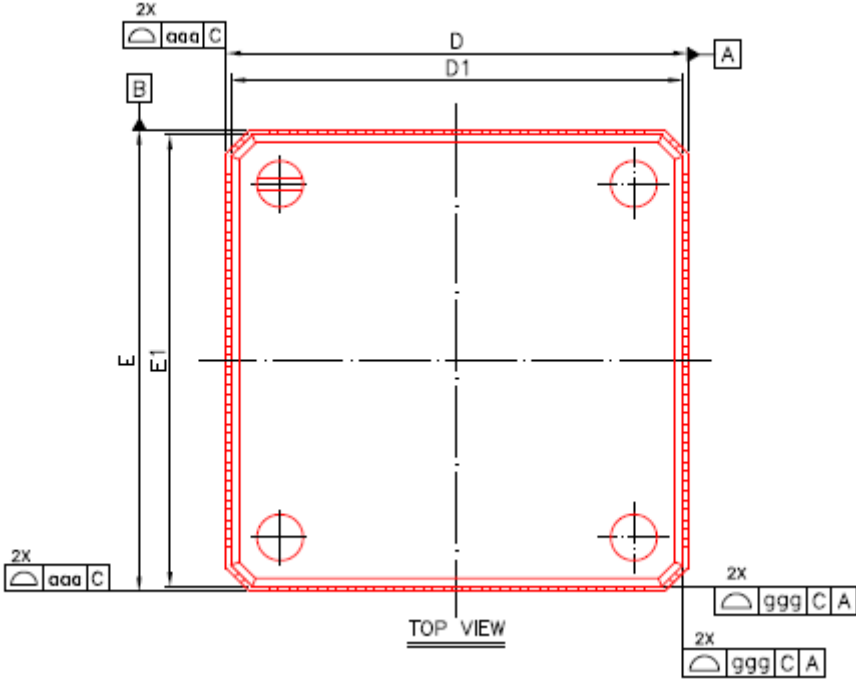

Figure 4-12 Top View

4.9.2.2 Side View

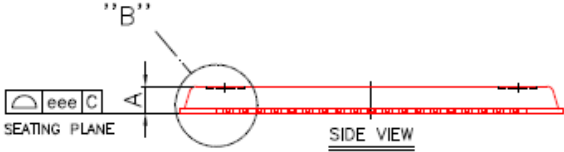

Figure 4-13 Side View

4.9.2.3 "B" Expanded

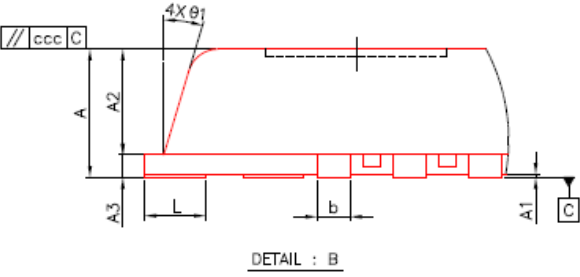

Figure 4-14 "B" Expanded

4.9.2.4 Bottom View

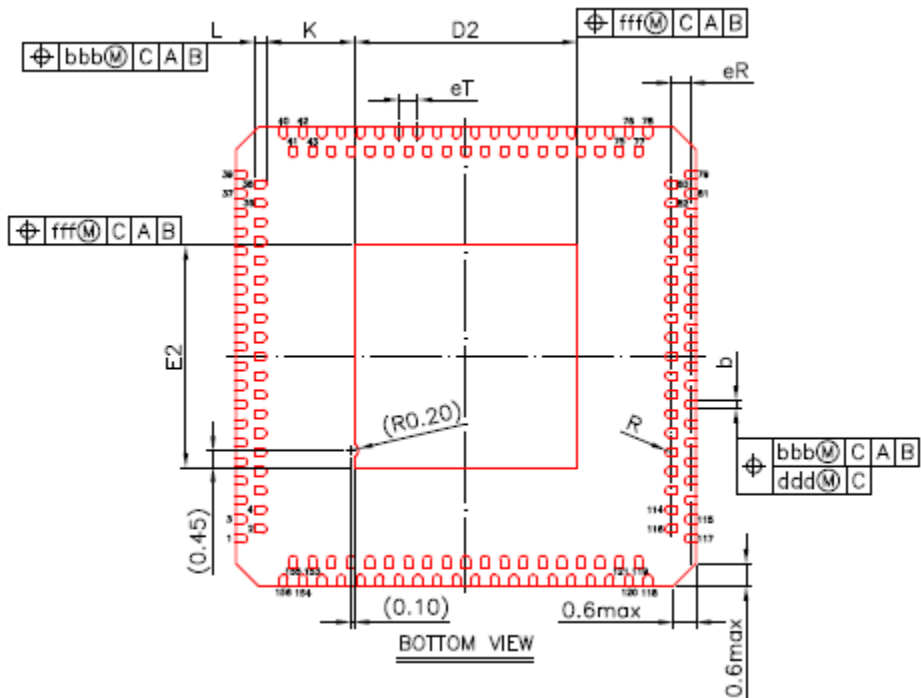

Figure 4-15 Bottom View

4.9.2.5 Package Diagram Key

Item	SYMBOL	MIN.	NOM.	MAX.
TOTAL THICKNESS	A	0.80	0.85	0.90
LEAD STAND OFF.	A1	0.00	0.02	0.05
MOLD THICKNESS	A2	0.65	0.70	0.75
L/F THICKNESS	A3	0.15 REF.		
LEAD WIDTH	b	0.18	0.22	0.30
PACKAGE SIZE	D	11.90	12.00	12.10
	E			
Mold Edge size	D1	11.75 BSC		
	E1	11.75 BSC		
E-PAD size	D2	5.70	5.80	5.90
	E2	5.70	5.80	5.90
LEAD LENGTH	L	0.20	0.30	0.40
LEAD PITCH (BSC.)	eT	0.50 BSC		
LEAD PITCH (BSC.)	eR	0.50 BSC		
ANGLE	θ1	5°	----	15°
LEAD ARC	R	0.09	----	0.14
Lead to E-PAD Tolerance	K	0.20	----	----
PKG EDGE TOLERANCE	aaa	0.10		
PACKAGE PROFILE OF A SURFACE	bbb	0.10		
LEAD PROFILE OF A SURFACE	ccc	0.10		
LEAD POSITION	ddd	0.05		
LEAD PROFILE OF A SURFACE	eee	0.08		
EPAD POSTION	fff	0.10		
Mold edge OF A & C SURFACE	ggg	0.20		

4.9.3 MT7688 AN/KN marking



YYWW: Date code
LLLLLLLLL : Lot number
“.” : Pin #1 dot

Figure 4-16 MT7688AN top marking



YYWW: Date code
LLLLLLLLLL : Lot number
“.” : Pin #1 dot

Figure 4-17 MT7688KN top marking

4.9.4 Reflow profile guideline

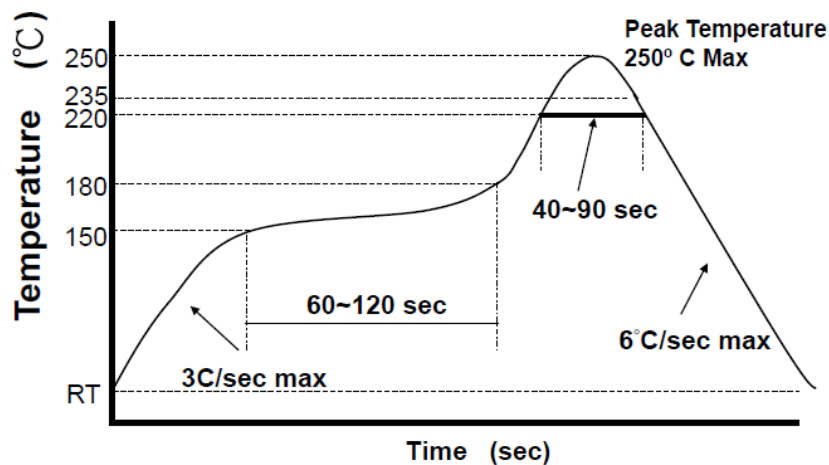

Figure 4-18 Reflow profile for MT7688

Notes:

1. Reflow profile guideline is designed for SnAgCulead-free solder paste.
2. Reflow temperature is defined at the solder ball of package/or the lead of package.
3. MTK would recommend customer following the solder paste vendor’s guideline to design a profile appropriate your line and products.
4. Appropriate N2 atmosphere is recommended since it would widen the process window and mitigate the risk for having solder open issues.

5. Register

5.1 Nomenclature

The following nomenclature is used for register types:

RO	Read Only
WO	Write Only
RW	Read or Write
RC	Read Clear
W1C	Write One Clear
-	Reserved bit
X	Undefined binary value

5.2 System Control

5.2.1 Features

- Provides read-only chip revision registers
- Provides a window to access boot-strapping signals
- Supports memory remapping configurations
- Supports software reset to each platform building block
- Provides registers to determine GPIO and other peripheral pin muxing schemes
- Provides some power-on-reset only test registers for software programmers
- Combines miscellaneous registers (such as clock skew control, status register, memo registers, etc)

5.2.2 Block Diagram

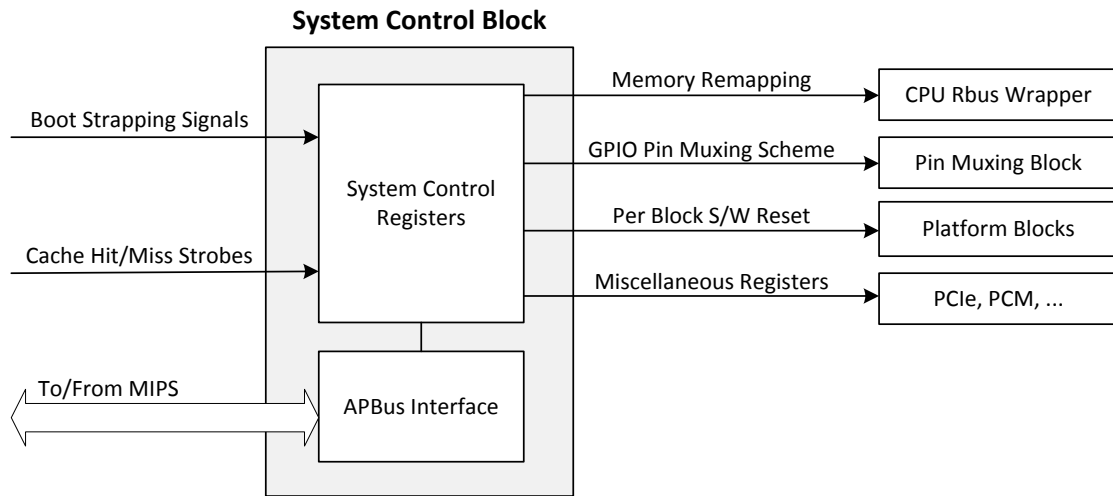

Figure 5-1 System Control Block Diagram

5.2.3 Registers

SYSCTL Changes LOG

Revision	Date	Author	Change Log
0.1	2013/10/3	PeterCT Wu	Initial for MT7628
0.2	2014/4/28	PeterCT Wu	MT7628 E2
0.3	2014/5/21	Morrie Lin	Add 4-bit SDXC on Router mode

Module name: SYSCTL Base address: (+10000000h)

Address	Name	Width	Register Function
10000000	<u>CHIPID0_3</u>	32	CHIP ID ASCII Character 0-3
10000004	<u>CHIPID4_7</u>	32	CHIP ID ASCII Character 4-7
10000008	<u>EE_CFG</u>	32	E-Fuse Configuration
1000000C	<u>CHIP_REV_ID</u>	32	Chip Revision Identification
10000010	<u>SYSCFG0</u>	32	System Configuration Register 0
10000014	<u>SYSCFG1</u>	32	System Configuration Register 1
10000018	<u>TESTSTAT</u>	32	Firmware Test Status
1000001C	<u>TESTSTAT2</u>	32	Firmware Test Status 2
10000028	<u>ROM_STATUS</u>	32	Andes ROM Status
1000002C	<u>CLKCFG0</u>	32	Clock Configuration Register 0
10000030	<u>CLKCFG1</u>	32	Clock Configuration Register 1
10000034	<u>RSTCTL</u>	32	Reset Control Register
10000038	<u>RSTSTAT</u>	32	Reset Status Register
1000003C	<u>AGPIO_CFG</u>	32	Analog GPIO Configuration
10000040	<u>N9_GPIO_INT</u>	32	Andes GPIO Interrupt
10000044	<u>N9_GPIO_MASK</u>	32	Andes GPIO Mask
10000060	<u>GPIO1_MODE</u>	32	GPIO1 purpose selection
10000064	<u>GPIO2_MODE</u>	32	GPIO2 purpose selection
10000068	<u>MEMO1</u>	32	Memory1
1000006C	<u>MEMO2</u>	32	Memory2
10000070	<u>EXT_MEMO1</u>	32	Extend Application #1
10000074	<u>EXT_MEMO2</u>	32	Extend Application #2
10000078	<u>EXT_MEMO3</u>	32	Extend Application #3
1000007C	<u>EXT_MEMO4</u>	32	Extend Application #4

10000000 CHIPID0_3 CHIP ID ASCII Character 0-3

3637544
D

Bit	31	30	29	28	27	26	25	24	23	22	21	20	19	18	17	16
Name	CHIP_ID3								CHIP_ID2							
Type	RO								RO							
Reset	0	0	1	1	0	1	1	0	0	0	1	1	0	1	1	1
Bit	15	14	13	12	11	10	9	8	7	6	5	4	3	2	1	0
Name	CHIP_ID1								CHIP_ID0							
Type	RO								RO							
Reset	0	1	0	1	0	1	0	0	0	1	0	0	1	1	0	1

Bit(s)	Name	Description
31:24	CHIP_ID3	ASCII CHIP Name Identification Character 3
23:16	CHIP_ID2	ASCII CHIP Name Identification Character 2
15:8	CHIP_ID1	ASCII CHIP Name Identification Character 1

Bit(s)	Name	Description
7:0	CHIP_ID0	ASCII CHIP Name Identification Character 0

10000004 CHIPID4_7 CHIP ID ASCII Character 4-7 2020383
2

Bit	31	30	29	28	27	26	25	24	23	22	21	20	19	18	17	16
Name	CHIP_ID7								CHIP_ID6							
Type	RO								RO							
Reset	0	0	1	0	0	0	0	0	0	0	1	0	0	0	0	0
Bit	15	14	13	12	11	10	9	8	7	6	5	4	3	2	1	0
Name	CHIP_ID5								CHIP_ID4							
Type	RO								RO							
Reset	0	0	1	1	1	0	0	0	0	0	1	1	0	0	1	0

Bit(s)	Name	Description
31:24	CHIP_ID7	ASCII CHIP Name Identification Character 3
23:16	CHIP_ID6	ASCII CHIP Name Identification Character 2
15:8	CHIP_ID5	ASCII CHIP Name Identification Character 1
7:0	CHIP_ID4	ASCII CHIP Name Identification Character 0

10000008 EE_CFG E-Fuse Configuration 0000000
0

Bit	31	30	29	28	27	26	25	24	23	22	21	20	19	18	17	16
Name	EE_CFG1															
Type	RO															
Reset	0	0	0	0	0	0	0	0	0	0	0	0	0	0	0	0
Bit	15	14	13	12	11	10	9	8	7	6	5	4	3	2	1	0
Name	EE_CFG0															
Type	RO															
Reset	0	0	0	0	0	0	0	0	0	0	0	0	0	0	0	0

Bit(s)	Name	Description
31:16	EE_CFG1	E-Fuse Configuration 1
15:0	EE_CFG0	E-Fuse Configuration 0

1000000C CHIP_REV_ID Chip Revision Identification 0001010
2

Bit	31	30	29	28	27	26	25	24	23	22	21	20	19	18	17	16
Name																PKG_ID
Type																RO
Reset																1
Bit	15	14	13	12	11	10	9	8	7	6	5	4	3	2	1	0
Name	VER_ID								ECO_ID							
Type	RO								RO							
Reset					0	0	0	1					0	0	1	0

Bit(s)	Name	Description
16	PKG_ID	Package ID 0: DRQFN10x10-110 1: DRQFN12x12-156
11:8	VER_ID	Chip Version ID
3:0	ECO_ID	Chip ECO ID

10000010 **SYSCFG0** System Configuration Register 0 0000010
0

Bit	31	30	29	28	27	26	25	24	23	22	21	20	19	18	17	16
Name	TEST_CODE								BS_SHADOW[8:4]							
Type	RW								RO							
Reset	0	0	0	0	0	0	0	0				0	0	0	0	0
Bit	15	14	13	12	11	10	9	8	7	6	5	4	3	2	1	0
Name	BS_SHADOW[3:0]							DBG_JTAG_MODE	TEST_MODE_1	XTAL_FREQ_SEL	EXT_BG	TEST_MODE_0	CHIP_MODE			DRAM_TYPE
Type	RO							RO	RO	RO	RO	RO	RO			RO
Reset	0	0	0	0				1	0	0	0	0	0	0	0	0

Bit(s)	Name	Description
31:24	TEST_CODE	Default value is from bootstrap and can be modified by software.
20:12	BS_SHADOW	BS shadow register for last boot-up value (by manual boot-strap SYSCFG1.PULL_EN) Displays a backup copy of the last bootup value
8	DBG_JTAG_MODE	JTAG for MIPS and Andes 1: Normal Boot-up 0: JTAG mode(MIPS & Andes)
7	TEST_MODE_1	Test Mode[1:0]
6	XTAL_FREQ_SEL	XTAL Frequency Selection 0: 25MHz DIP 1: 40MHz SMD (3225)
5	EXT_BG	External BG Clock 0: BG clock from PMU 1: BG clock from the external pin
4	TEST_MODE_0	Test Mode[1:0] 0: SUTIF 1: 3-wire SPI
3:1	CHIP_MODE	Chip Mode A vector to set chip function/test/debug modes in non-test/debug operation. For more information see the Bootstrapping Pins Description in the datasheet for this chip. 000: Boot from PLL (boot from SPI 3-Byte ADR) 001: Boot from PLL (boot from SPI 4-Byte ADR) 010: Boot from XTAL (boot from SPI 3-Byte ADR) 011: Boot from XTAL (boot from SPI 4-Byte ADR) 100: SCAN mode 101: IDDQ mode 110: Power-On mode 111: UTIF test mode
0	DRAM_TYPE	DDR type [note] This DDR attribute is not valid for KN package.. (7628KN has DDR1 KGD) 0: DDR2 1: DDR1

10000014 **SYSCFG1** System Configuration Register 1 0000000
0

Bit	31	30	29	28	27	26	25	24	23	22	21	20	19	18	17	16
Name																PULL_EN

Type																	RW
Reset																	0
Bit	15	14	13	12	11	10	9	8	7	6	5	4	3	2	1	0	
Name																	
Type																	
Reset																	

Bit(s)	Name	Description
16	PULL_EN	Internal Manual Boot-Strap 1: enable 0: disable

1000018 TESTSTAT **Firmware Test Status** **0000000**
0

Bit	31	30	29	28	27	26	25	24	23	22	21	20	19	18	17	16
Name	TESTSTAT[31:16]															
Type	RW															
Reset	0	0	0	0	0	0	0	0	0	0	0	0	0	0	0	0
Bit	15	14	13	12	11	10	9	8	7	6	5	4	3	2	1	0
Name	TESTSTAT[15:0]															
Type	RW															
Reset	0	0	0	0	0	0	0	0	0	0	0	0	0	0	0	0

Bit(s)	Name	Description
31:0	TESTSTAT	Firmware Test Status register NOTE: This register is reset only by a power-on reset.

100001C TESTSTAT2 **Firmware Test Status 2** **0000000**
0

Bit	31	30	29	28	27	26	25	24	23	22	21	20	19	18	17	16
Name	TESTSTAT2[31:16]															
Type	RW															
Reset	0	0	0	0	0	0	0	0	0	0	0	0	0	0	0	0
Bit	15	14	13	12	11	10	9	8	7	6	5	4	3	2	1	0
Name	TESTSTAT2[15:0]															
Type	RW															
Reset	0	0	0	0	0	0	0	0	0	0	0	0	0	0	0	0

Bit(s)	Name	Description
31:0	TESTSTAT2	Firmware Test Status Register 2 NOTE: This register is reset only by a power-on reset.

1000028 ROM_STATU **Andes ROM Status** **0000000**
S **0**

Bit	31	30	29	28	27	26	25	24	23	22	21	20	19	18	17	16
Name																
Type																
Reset																
Bit	15	14	13	12	11	10	9	8	7	6	5	4	3	2	1	0
Name									STATUS							
Type									RO							
Reset									0	0	0	0	0	0	0	0

Bit(s)	Name	Description
7:0	STATUS	Andes ROM Status 0: Power-on default

Bit(s)	Name	Description
		1: ROM initialization done 2: Wifi driver loaded

100002C CLKCFG0 Clock Configuration Register 0 0020100
0

Bit	31	30	29	28	27	26	25	24	23	22	21	20	19	18	17	16	
Name			OSC_1US_DIV							INT_CLK_FDIV						INT_CLK_FRAC[4:4]	
Type			RW							RW						RW	
Reset			0	0	0	0	0	0		0	1	0	0	0		0	
Bit	15	14	13	12	11	10	9	8	7	6	5	4	3	2	1	0	
Name	INT_CLK_FFRAC[3:0]				REFCLK0_RATE					DIS_N9		PCI_E_EXT_125M	PE_RL_CLK_SEL	DIS_BP_SLEP	EN_BB_PCLK	CP_UFRM_BP	CP_UFRM_XTAL
Type	RW				RW					RW		RW	RW	RW	RW	RW	RW
Reset	0	0	0	1	0	0	0		0		0	0	0	0	0	0	

Bit(s)	Name	Description
29:24	OSC_1US_DIV	<p>Oscillator 1 usec Divider</p> <p>Sets the maximum for the reference clock counter for either a 20 MHz or 40 MHz external XTAL input. The count increments each 1usec (indicating 1 MHz), up to the maximum, before resetting to zero. This counts the frequency of an external XTAL. This count is used to output a 32 KHz frequency to the REFCLK0 pin.</p> <p>0: Automatically generates a 1 usec system tick regardless of whether XTAL frequency is 20 MHz or 40 MHz. 39: Default value for an external 40 MHz XTAL. 19: Default value for an external 20 MHz XTAL. Others: Manual mode for tick generation.</p>
22:18	INT_CLK_FDIV	<p>Internal Clock Frequency Divider for I2S/PCM</p> <p>The frequency divider used to generate the Fraction-N clock frequency. Valid values range from 1 to 31. Fraction-N clock frequency = (INT_CLK_FFRAC/INT_CLK_FDIV)*PLL_FREQ</p>
16:12	INT_CLK_FFRAC	<p>Internal Clock Fraction-N Frequency for I2S/PCM</p> <p>A parameter used in conjunction with INT_CLK_FDIV to generate the Fraction-N clock frequency. Valid values range from 0 to 31. Fraction-N clock Frequency = (INT_CLK_FFRAC/INT_CLK_FDIV)*PLL_FREQ</p>
11:9	REFCLK0_RATE	<p>Output clock rate of reference Clock 0</p> <p>7: CPUPLL Clock/8 6: Off 5: Internal Fraction-N_CLK/2 (I2S/PCM) 4: 48 MHz 3: 40 MHz 2: 25 MHz 1: 12 MHz 0: Xtal clock(25/40 MHz by boot strap)</p>
7	DIS_N9	<p>Pause Andes Execution</p> <p>[Note] This bit is initialized by HW STRAP and can be changed by SW afterwards. 1: Enable 0: default</p>
5	PCI_E_EXT_125M	<p>PCIe 125MHZ Clock Source</p> <p>1: Ext. 125MHz Source (EPHY)</p>

Bit(s)	Name	Description
4	PERI_CLK_SEL	Peripheral Clock Source Select 0: PCIe PHY 125M 1: XTAL input
3	DIS_BBP_SLEEP	BBPPLL Sleep Mode Control 0: 40 MHz from BBP 480 MHz divided by 12 1: Disable BBPPLL entering SLEEP mode 0: BBPPLL SLEEP mode
2	EN_BBP_CLK	BBPPLL 480MHz Clock 1: BBPPLL Clock Enable 0: BBPPLL Clock Disable
1	CPU_FRM_BBP	CPU clock from BBPPLL 1: 480MHz BBPPLL 0: 580MHz CPUPLL
0	CPU_FRM_XTAL	CPU clock from XTAL [Note] This bit is initialized by HW STRAP and can be changed by SW afterwards. 1: XTAL input 0: CPUPLL

10000030 CLKCFG1 Clock Configuration Register 1 F69F7F0
0

Bit	31	30	29	28	27	26	25	24	23	22	21	20	19	18	17	16
Name	PWM_CLK_EN	SDXC_CLK_EN	CRYPTO_CLK_EN	MIPSC_CLK_EN		PCI2_CLK_EN	UPHY_CLK_EN		ETH_CLK_EN			UART2_CLK_EN	UART1_CLK_EN	SPI_CLK_EN	I2S_CLK_EN	I2C_CLK_EN
Type	RW	RW	RW	RW		RW	RW		RW			RW	RW	RW	RW	RW
Reset	1	1	1	1		1	1		1			1	1	1	1	1
Bit	15	14	13	12	11	10	9	8	7	6	5	4	3	2	1	0
Name		GDMA_CLK_EN	PIORTO_CLK_EN	UART0_CLK_EN	PCM_CLK_EN	MC_CLK_EN	INT_CLK_EN	TIMER_CLK_EN								
Type		RW	RW	RW	RW	RW	RW	RW								
Reset		1	1	1	1	1	1	1								

Bit(s)	Name	Description
31	PWM_CLK_EN	PWM clock control 1: Clock Enable 0: Clock Disable
30	SDXC_CLK_EN	SDXC clock control 1: Clock Enable 0: Clock Disable
29	CRYPTO_CLK_EN	AUX system tick counter clock control 1: Clock Enable 0: Clock Disable
28	MIPSC_CLK_EN	MIPS Counter clock control 1: Clock Enable 0: Clock Disable
26	PCI2_CLK_EN	PCI2 clock control 1: Clock Enable 0: Clock Disable
25	UPHY_CLK_EN	UPHY clock control 1: Clock Enable 0: Clock Disable

Bit(s)	Name	Description
23	ETH_CLK_EN	ETH clock control 1: Clock Enable 0: Clock Disable
20	UART2_CLK_EN	UART2 clock control 1: Clock Enable 0: Clock Disable
19	UART1_CLK_EN	UART1 clock control 1: Clock Enable 0: Clock Disable
18	SPI_CLK_EN	SPI clock control 1: Clock Enable 0: Clock Disable
17	I2S_CLK_EN	I2S clock control 1: Clock Enable 0: Clock Disable
16	I2C_CLK_EN	I2C clock control 1: Clock Enable 0: Clock Disable
14	GDMA_CLK_EN	GDMA clock control 1: Clock Enable 0: Clock Disable
13	PIO_CLK_EN	PIO clock control 1: Clock Enable 0: Clock Disable
12	UART0_CLK_EN	UART0 clock control 1: Clock Enable 0: Clock Disable
11	PCM_CLK_EN	PCM clock control 1: Clock Enable 0: Clock Disable
10	MC_CLK_EN	MC clock control 1: Clock Enable 0: Clock Disable
9	INT_CLK_EN	INT clock control 1: Clock Enable 0: Clock Disable
8	TIMER_CLK_EN	TIMER clock control 1: Clock Enable 0: Clock Disable

1000034 RSTCTL
Reset Control Register
0400040
0

Bit	31	30	29	28	27	26	25	24	23	22	21	20	19	18	17	16
Name	PW M_ RS T	SD XC_ RS T	CR YPT O_ RS T	AU X_ S TC K_ RS T		PCI E_ RS T		EP HY_ RS T	ET H_ RS T	UH ST_ RS T		UA RT2_ RS T	UA RT1_ RS T	SPI _RS T	I2S _RS T	I2C _RS T
Type	RW	RW	RW	RW		RW		RW	RW	RW		RW	RW	RW	RW	RW
Reset	0	0	0	0		1		0	0	0		0	0	0	0	0
Bit	15	14	13	12	11	10	9	8	7	6	5	4	3	2	1	0
Name		GD MA_ RS T	PIO _RS T	UA RT0_ RS T	PC M_ RS T	MC _RS T	INT _RS T	TIM ER_ RS T			HIF _RS T	WIF I_ RS T	SPI S_ RS T			SY S_ RS T
Type		RW	RW	RW	RW	RW	RW	RW			RW	RW	RW			W1 C

Reset		0	0	0	0	1	0	0			0	0	0			0
--------------	--	---	---	---	---	---	---	---	--	--	---	---	---	--	--	---

Bit(s)	Name	Description
31	PWM_RST	PWM reset control 1: Reset Assert 0: Reset Deassert
30	SDXC_RST	SDXC reset control 1: Reset Assert 0: Reset Deassert
29	CRYPTO_RST	Crypto engine reset control 1: Reset Assert 0: Reset Deassert
28	AUX_STCK_RST	AUX system tick counter clock control 1: Reset Assert 0: Reset Deassert
26	PCIE_RST	PCIE reset control 1: Reset Assert 0: Reset Deassert
24	EPHY_RST	EPHY reset control 1: Reset Assert 0: Reset Deassert
23	ETH_RST	ETH reset control 1: Reset Assert 0: Reset Deassert
22	UHST_RST	USB PHY reset control 1: Reset Assert 0: Reset Deassert
20	UART2_RST	UART2 reset control 1: Reset Assert 0: Reset Deassert
19	UART1_RST	UART1 reset control 1: Reset Assert 0: Reset Deassert
18	SPI_RST	SPI reset control 1: Reset Assert 0: Reset Deassert
17	I2S_RST	I2S reset control 1: Reset Assert 0: Reset Deassert
16	I2C_RST	I2C reset control 1: Reset Assert 0: Reset Deassert
14	GDMA_RST	GDMA reset control 1: Reset Assert 0: Reset Deassert
13	PIO_RST	PIO reset control 1: Reset Assert 0: Reset Deassert
12	UART0_RST	UART0 reset control 1: Reset Assert 0: Reset Deassert
11	PCM_RST	PCM reset control 1: Reset Assert 0: Reset Deassert
10	MC_RST	MC reset control 1: Reset Assert 0: Reset Deassert

Bit(s)	Name	Description
9	INT_RST	INT reset control 1: Reset Assert 0: Reset Deassert
8	TIMER_RST	TIMER reset control 1: Reset Assert 0: Reset Deassert
5	HIF_RST	WIFI HIF reset control [Note] WPDMA reset control 1: Reset Assert 0: Reset Deassert
4	WIFI_RST	WIFI reset control [Note] This bit will reset Andes and initialize XTAL and BBPLL again, MIPS must carefully use it. 1: Reset Assert 0: Reset Deassert
3	SPIS_RST	SPI Slave control 1: Reset Assert 0: Reset Deassert
0	SYS_RST	Whole System Reset Control [Note] Except for power-on CR, this bit reset the whole system include itself. 1: Whole System Reset 0: NA

10000038 RSTSTAT Reset Status Register C003000
0

Bit	31	30	29	28	27	26	25	24	23	22	21	20	19	18	17	16
Name	WD T2S YS RS T_EN	WD T2R ST O_EN	WDRSTPD													
Type	RW	RW	RW													
Reset	1	1	0	0	0	0	0	0	0	0	0	0	0	0	1	1
Bit	15	14	13	12	11	10	9	8	7	6	5	4	3	2	1	0
Name							WD RS T_ON 9_EN	N9 WD RS T_EN					N9S YS RS T	SW SYS RST	WD RS T	
Type							RW	RW					W1 C	W1 C	W1 C	
Reset							0	0					0	0	0	

Bit(s)	Name	Description
31	WDT2SYSRST_EN	WDT reset apply to System Reset Enables watchdog timeout to trigger a system reset. 1: Enable 0: Disable
30	WDT2RSTO_EN	WDT reset apply to watch dog reset pin out. 1: Enable 0: Disable
29:16	WDRSTPD	Watchdog Reset Output Low Period Controls the WDT reset output low period. For example: If the pin share mode was set correctly and WDT2RSTO_EN=1, When WDRSTPD= 0, you can see duration of 1 usec low on the WDT reset output pin. When WDRSTPD= 3, you can see duration of 4 usec low on the WDT reset output pin.

Bit(s)	Name	Description
		(unit: 1 usec)
9	WDRST_TON9_EN	MIPS software reset or watch-dog reset apply to N9 subsys. When this bit is set, MIPS can reset N9 or N9 is reset when MIPS watch-dog reset happen. 0: disable 1: Enable
8	N9_WDRST_EN	N9 watch-dog reset applies to MIPS subsys. When N9 WDRST happens, N9 will also reset MIPS system. 0: disable 1: Enable
3	N9SYSRST	N9 watch-dog reset occurred This bit will be set if N9 wifisys is reset by its watch-dog mechanism. Writing a '1' will clear this bit. Writing a '0' has not effect. NOTE: This register is reset only by a power on reset. 0: Has no effect. 1: Clears this bit.
2	SWSYSRST	Software system reset occurred This bit will be set if software reset the chip by writing to the RSTSYS bit in RSTCTL. Writing a '1' will clear this bit. Writing a '0' has not effect. NOTE: This register is reset only by a power on reset. 0: Has no effect. 1: Clears this bit.
1	WDRST	Watchdog reset occurred This bit will be set if the watchdog timer reset the chip. Writing a '1' will clear this bit. Writing a '0' has not effect. NOTE: This register is reset only by power-on reset. 0: Has no effect. 1: Clears this bit.

100003C **AGPIO_CFG** Analog GPIO Configuration

001F001
F

Bit	31	30	29	28	27	26	25	24	23	22	21	20	19	18	17	16
Name												EPHY_GPIO_AIO_EN				EPHY_P0_DIS
Type												RW				RW
Reset												1	1	1	1	1
Bit	15	14	13	12	11	10	9	8	7	6	5	4	3	2	1	0
Name				RF_OLT_MODE			EINTSEL	WLED_OD_EN				REFCLK_OAIO_EN	I2S_CLK_AIO_EN	I2S_WS_AIO_EN	I2S_SD_OAIO_EN	I2S_SD_OAIO_EN
Type				RW			RW	RW				RW	RW	RW	RW	RW
Reset				0			0	0				1	1	1	1	1

Bit(s)	Name	Description
20:17	EPHY_GPIO_AIO_EN	EPHY P1 ~ P4 digital PAD selection (P1 ~ P4 Disable) (note: When any bit of bit[20:17] is set to 1, P1 ~ P4 will be switched to digital PADs together.) 0: Analog PAD 1: Digital PAD
16	EPHY_P0_DIS	EPHY P0 Disable 0: Enable 1: Disable
12	RF_OLT_MODE	Enable RF OLT mode 0: Disable 1: Enable

Bit(s)	Name	Description
9	EINT_SEL	Andes EINT Source 0: from W_UTIF 1: from GPIO [23:20]
8	WLED_OD_EN	WLED Open-Drain 0: Disable 1: Open-Drain
4	REF_CLKO_AIO_EN	REF Clock Output PAD Selection 0: Analog PAD 1: Digital PAD
3	I2S_CLK_AIO_EN	I2S Clock PAD Selection 0: Analog PAD 1: Digital PAD
2	I2S_WS_AIO_EN	I2S WS PAD Selection 0: Analog PAD 1: Digital PAD
1	I2S_SDO_AIO_EN	I2S CSDO PAD Selection 0: Analog PAD 1: Digital PAD
0	I2S_SDI_AIO_EN	I2S SDI PAD Selection 0: Analog PAD 1: Digital PAD

1000040 **N9 GPIO INT** **Andes GPIO Interrupt** **0000000**
0

Bit	31	30	29	28	27	26	25	24	23	22	21	20	19	18	17	16
Name																GPIO_INT[16:16]
Type																W1C
Reset																0
Bit	15	14	13	12	11	10	9	8	7	6	5	4	3	2	1	0
Name	GPIO_INT[15:0]															
Type	W1C															
Reset	0	0	0	0	0	0	0	0	0	0	0	0	0	0	0	0

Bit(s)	Name	Description
16:0	GPIO_INT	Andes GPIO INT

1000044 **N9 GPIO MASK** **Andes GPIO Mask** **0001FFF**
F

Bit	31	30	29	28	27	26	25	24	23	22	21	20	19	18	17	16
Name																GPIO_MASK[16:16]
Type																RW
Reset																1
Bit	15	14	13	12	11	10	9	8	7	6	5	4	3	2	1	0
Name	GPIO_MASK[15:0]															
Type	RW															
Reset	1	1	1	1	1	1	1	1	1	1	1	1	1	1	1	1

Bit(s)	Name	Description
16:0	GPIO_MASK	Andes GPIO MASK

1000060 GPIO1_MODE GPIO1 purpose selection
**5405040
4**

Bit	31	30	29	28	27	26	25	24	23	22	21	20	19	18	17	16
Name	PWM1_MODE		PWM0_MODE		UART2_MODE		UART1_MODE				I2C_MODE			REFCLK_MODE		PERST_MODE
Type	RW		RW		RW		RW				RW			RW		RW
Reset	0	1	0	1	0	1	0	0			0	0		1		1
Bit	15	14	13	12	11	10	9	8	7	6	5	4	3	2	1	0
Name		WDT_MODE		SPI_MODE	SD_MODE		UART0_MODE		I2S_MODE		SPI_CS1_MODE		SPIS_MODE		GPIO_MODE	
Type		RW		RW	RW		RW		RW		RW		RW		RW	
Reset		0		0	0	1	0	0	0	0	0	0	0	1	0	0

Bit(s)	Name	Description
31:30	PWM1_MODE	PWM1 GPIO mode 3: SDXC D6 2: UTIF[5] 1: GPIO 0: PWM ch1
29:28	PWM0_MODE	PWM0 GPIO mode 3: SDXC D7 2: UTIF[4] 1: GPIO 0: PWM ch0
27:26	UART2_MODE	UART2 GPIO mode 3: SDXC D5/D4 2: PWM ch2/ch3 1: GPIO 0: UART-Lite #2
25:24	UART1_MODE	UART1 GPIO mode 3: SW_R, SW_T 2: PWM ch0/ch1 1: GPIO 0: UART-Lite #1
21:20	I2C_MODE	I2C GPIO mode 2: S-UART (debug) 1: GPIO 0: I2C
18	REFCLK_MODE	REFCLK GPIO mode 1: GPIO 0: REFCLK (12M)
16	PERST_MODE	PCIe RESET GPIO mode 1: GPIO 0: PCIe reset
15	ESD_MODE	SDXC Router mode 1: SDXC from I2S/I2C/GPIO0/UART1 pins 0: SDXC from EPHY pins
14	WDT_MODE	Watch dog timeout GPIO mode 1: GPIO 0: Watch dog
12	SPI_MODE	SPI GPIO mode 1: GPIO

Bit(s)	Name	Description
11:10	SD_MODE	SDXC GPIO mode 3: Andes JTAG 2: UTIF[17:10] 1: GPIO 0: SDXC
9:8	UART0_MODE	UART0 GPIO mode 1: GPIO 0: UART-Lite #0
7:6	I2S_MODE	I2S GPIO mode 3: ANTSEL[5:2] 2: PCM 1: GPIO 0: I2S
5:4	SPI_CS1_MODE	SPI CS1 GPIO mode 2: REFCLK 1: GPIO 0: SPI CS1
3:2	SPIS_MODE	SPI Slave GPIO mode 3: PWM CH0/1 and UART2 2: UTIF[3:0] 1: GPIO 0: SPI Slave
1:0	GPIO_MODE	GPIO mode 3: PCIe Reset 2: REFCLK (12M) 1: GPIO 0: GPIO

1000064 **GPIO2_MODE** GPIO2 purpose selection

0555055
5

Bit	31	30	29	28	27	26	25	24	23	22	21	20	19	18	17	16
Name					P4_LED_K N_MODE	P3_LED_K N_MODE	P2_LED_K N_MODE	P1_LED_K N_MODE	P0_LED_K N_MODE	WLED_KN _MODE						
Type					RW	RW	RW	RW	RW	RW						
Reset					0	1	0	1	0	1	0	1	0	1	0	1
Bit	15	14	13	12	11	10	9	8	7	6	5	4	3	2	1	0
Name					P4_LED_A N_MODE	P3_LED_A N_MODE	P2_LED_A N_MODE	P1_LED_A N_MODE	P0_LED_A N_MODE	WLED_AN _MODE						
Type					RW	RW	RW	RW	RW	RW						
Reset					0	1	0	1	0	1	0	1	0	1	0	1

Bit(s)	Name	Description
27:26	P4_LED_KN_MODE	EPHY P4 LED GPIO mode [Note] Only valid for MT7628KN. 3: JTAG (JTRST_N) 2: UTIF[6] 1: GPIO 0: EPHY P4 LED
25:24	P3_LED_KN_MODE	EPHY P3 LED GPIO mode [Note] Only valid for MT7628KN. 3: JTAG (JTCLK) 2: UTIF[7] 1: GPIO 0: EPHY P3 LED
23:22	P2_LED_KN_MODE	EPHY P2 LED GPIO mode [Note] Only valid for MT7628KN. 3: JTAG (JTMS) 2: UTIF[8]

Bit(s)	Name	Description
21:20	P1_LED_KN_MODE	1: GPIO 0: EPHY P2 LED EPHY P1 LED GPIO mode [Note] Only valid for MT7628KN. 3: JTAG (JTDI) 2: UTIF[9] 1: GPIO 0: EPHY P1 LED
19:18	P0_LED_KN_MODE	EPHY P0 LED GPIO mode [Note] Only valid for MT7628KN. 3: JTAG(JTDO) 2: Reserved 1: GPIO 0: EPHY P0 LED
17:16	WLED_KN_MODE	WLED GPIO mode [Note] Only valid for MT7628KN. 3: Reserved 2: Reserved 1: GPIO 0: WLED
11:10	P4_LED_AN_MODE	EPHY P4 LED GPIO mode [Note] Only valid for MT7628AN. 3: JTAG (JTRST_N) 2: UTIF[6] 1: GPIO 0: EPHY P4 LED
9:8	P3_LED_AN_MODE	EPHY P3 LED GPIO mode [Note] Only valid for MT7628AN. 3: JTAG (JTCLK) 2: UTIF[7] 1: GPIO 0: EPHY P3 LED
7:6	P2_LED_AN_MODE	EPHY P2 LED GPIO mode [Note] Only valid for MT7628AN. 3: JTAG (JTMS) 2: UTIF[8] 1: GPIO 0: EPHY P2 LED
5:4	P1_LED_AN_MODE	EPHY P1 LED GPIO mode [Note] Only valid for MT7628AN. 3: JTAG (JTDI) 2: UTIF[9] 1: GPIO 0: EPHY P1 LED
3:2	P0_LED_AN_MODE	EPHY P0 LED GPIO mode [Note] Only valid for MT7628AN. 3: JTAG(JTDO) 2: Reserved 1: GPIO 0: EPHY P0 LED
1:0	WLED_AN_MODE	WLED GPIO mode [Note] Only valid for MT7628AN. 3: Reserved 2: Reserved 1: GPIO 0: WLED

1000068 **MEMO1**
Memory1
0000000
0

Bit	31	30	29	28	27	26	25	24	23	22	21	20	19	18	17	16
Name	MEMO1[31:16]															
Type	RW															
Reset	0	0	0	0	0	0	0	0	0	0	0	0	0	0	0	0
Bit	15	14	13	12	11	10	9	8	7	6	5	4	3	2	1	0
Name	MEMO1[15:0]															
Type	RW															
Reset	0	0	0	0	0	0	0	0	0	0	0	0	0	0	0	0

Bit(s)	Name	Description
31:0	MEMO1	Memory1

100006C **MEMO2** **Memory2** **0000000**
0

Bit	31	30	29	28	27	26	25	24	23	22	21	20	19	18	17	16
Name	MEMO2[31:16]															
Type	RW															
Reset	0	0	0	0	0	0	0	0	0	0	0	0	0	0	0	0
Bit	15	14	13	12	11	10	9	8	7	6	5	4	3	2	1	0
Name	MEMO2[15:0]															
Type	RW															
Reset	0	0	0	0	0	0	0	0	0	0	0	0	0	0	0	0

Bit(s)	Name	Description
31:0	MEMO2	Memory2

1000070 **EXT_MEMO1** **Extend Application #1** **0000000**
0

Bit	31	30	29	28	27	26	25	24	23	22	21	20	19	18	17	16
Name	MEMO1[31:16]															
Type	RW															
Reset	0	0	0	0	0	0	0	0	0	0	0	0	0	0	0	0
Bit	15	14	13	12	11	10	9	8	7	6	5	4	3	2	1	0
Name	MEMO1[15:0]															
Type	RW															
Reset	0	0	0	0	0	0	0	0	0	0	0	0	0	0	0	0

Bit(s)	Name	Description
31:0	MEMO1	Extend Application #1

1000074 **EXT_MEMO2** **Extend Application #2** **0000000**
0

Bit	31	30	29	28	27	26	25	24	23	22	21	20	19	18	17	16
Name	MEMO2[31:16]															
Type	RW															
Reset	0	0	0	0	0	0	0	0	0	0	0	0	0	0	0	0
Bit	15	14	13	12	11	10	9	8	7	6	5	4	3	2	1	0
Name	MEMO2[15:0]															
Type	RW															
Reset	0	0	0	0	0	0	0	0	0	0	0	0	0	0	0	0

Bit(s)	Name	Description
31:0	MEMO2	Extend Application #2

10000078 **EXT_MEMO3** **Extend Application #3** **0000000**
0

Bit	31	30	29	28	27	26	25	24	23	22	21	20	19	18	17	16
Name	MEMO3[31:16]															
Type	RW															
Reset	0	0	0	0	0	0	0	0	0	0	0	0	0	0	0	0
Bit	15	14	13	12	11	10	9	8	7	6	5	4	3	2	1	0
Name	MEMO3[15:0]															
Type	RW															
Reset	0	0	0	0	0	0	0	0	0	0	0	0	0	0	0	0

Bit(s)	Name	Description
31:0	MEMO3	Extend Application #3

1000007C **EXT_MEMO4** **Extend Application #4** **0000000**
0

Bit	31	30	29	28	27	26	25	24	23	22	21	20	19	18	17	16
Name	MEMO4[31:16]															
Type	RW															
Reset	0	0	0	0	0	0	0	0	0	0	0	0	0	0	0	0
Bit	15	14	13	12	11	10	9	8	7	6	5	4	3	2	1	0
Name	MEMO4[15:0]															
Type	RW															
Reset	0	0	0	0	0	0	0	0	0	0	0	0	0	0	0	0

Bit(s)	Name	Description
31:0	MEMO4	Extend Application #4

5.3 Timer

5.3.1 Features

- Independent 1usec tick pre-scale for each timer.
- Independent interrupts for each timer.
- Two general-purpose timers and a watchdog timer. Watchdog timer resets system on time-out.
- Timer Modes
 - *Periodic*
 In periodic mode, the timer counts down to zero from the limited value. An interrupt is generated when the count is zero. After reaching zero, the limited value is reloaded into the timer and the timer counts down again. A limited value of zero disables the timer.
 - *Timeout*
 In timeout mode, the timer counts down to zero from the limited value. An interrupt is generated when the count is zero. In this mode, the ENABLE bit is reset when the timer reaches zero, stopping the counter.
 - *Watchdog*
 In watchdog mode, the timer counts down to zero from the limited value. If the load value is not reloaded or the timer is not disabled before the count is zero, the chip will be reset. When this occurs, every register in the chip is reset except the watchdog reset status bit WDRST in the RSTSTAT register in the system control block; it remains set to alert firmware of the timeout event when it re-executes its bootstrap.

5.3.2 Block Diagram

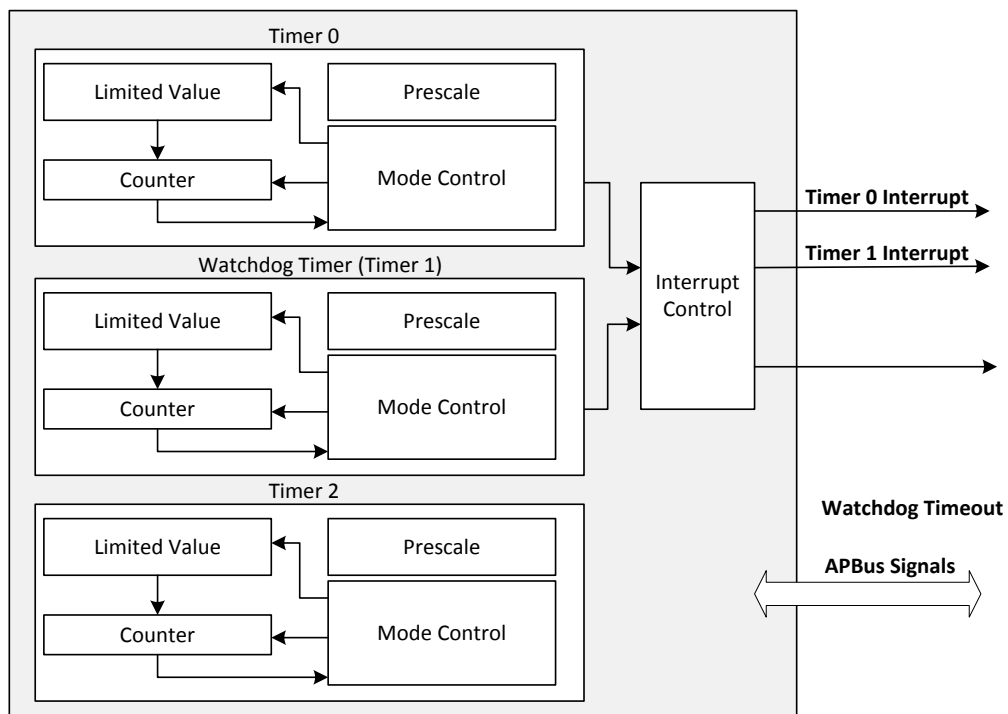

Figure 5-2 Timer Block Diagram

5.3.3 Registers

TIMER Changes LOG

Revision	Date	Author	Change Log
0.1	2012/8/24	Leon Chung	Initialization
0.2	2013/12/10	Rick Ho	1. Modify T0CTL_REG Bit[4] to WO and add Bit[3] RO 2. Modify WDTCTL_REG Bit[4] to WO and add Bit[3] RO 3. Modify T1CTL_REG Bit[4] to WO and add Bit[3] RO

Module name: TIMER Base address: (+10000100h)

Address	Name	Width	Register Function
10000100	<u>TGLB_REG</u>	32	RISC Global Control Register
10000110	<u>TOCTL_REG</u>	32	RISC Timer 0 Control Register
10000114	<u>TOLMT_REG</u>	32	RISC Timer 0 Limit Register
10000118	<u>T0_REG</u>	32	RISC Timer 0 Register
10000120	<u>WDTCTL_REG</u>	32	Watch Dog Timer Control Register
10000124	<u>WDTLMT_REG</u>	32	Watch Dog Timer Limit Register
10000128	<u>WDT_REG</u>	32	Watch Dog Timer Register
10000130	<u>T1CTL_REG</u>	32	RISC Timer 1 Control Register
10000134	<u>T1LMT_REG</u>	32	RISC Timer 1 Limit Register
10000138	<u>T1_REG</u>	32	RISC Timer 1 Register

10000100 TGLB_REG RISC Global Control Register 00000000

Bit	31	30	29	28	27	26	25	24	23	22	21	20	19	18	17	16
Name	RESV1[20:5]															
Type	RO															
Reset	0	0	0	0	0	0	0	0	0	0	0	0	0	0	0	0
Bit	15	14	13	12	11	10	9	8	7	6	5	4	3	2	1	0
Name	RESV1[4:0]					T1RST	WDTRST	T0RST	RESV0					T1INT	WDTINT	T0INT
Type	RO					W1C	W1C	W1C	RO					W1C	W1C	W1C
Reset	0	0	0	0	0	0	0	0	0	0	0	0	0	0	0	0

Bit(s)	Name	Description
31:11	RESV1	Reserved
10	T1RST	Timer 1 reset 1: to reset timer 1 to T1LMT value
9	WDTRST	Watch dog timer reset 1: to reset watch dog timer to WDTLMT value
8	T0RST	Timer 0 reset 1: to reset timer 0 to TOLMT value
7:3	RESV0	Reserved
2	T1INT	Timer 1 interrupt status
1	WDTINT	Watch dog timer interrupt status
0	T0INT	Timer 0 interrupt status

10000110 TOCTL_REG RISC Timer 0 Control Register 00000000

Bit	31	30	29	28	27	26	25	24	23	22	21	20	19	18	17	16
Name	TOPRES															

Type	RW																
Reset	0	0	0	0	0	0	0	0	0	0	0	0	0	0	0	0	
Bit	15	14	13	12	11	10	9	8	7	6	5	4	3	2	1	0	
Name	RESV2								TOEN	RESV1			TOAL	TOAL_STATUS	RESV0		
Type	RO								RW	RO			WO	RO	RO		
Reset	0	0	0	0	0	0	0	0	0	0	0	0	0	0	0	0	

Bit(s)	Name	Description
31:16	TOPRES	Timer 0 count down tick pre-scale. Unit is 1u second.
15:8	RESV2	Reserved
7	TOEN	Timer 0 count down enable
6:5	RESV1	Reserved
4	TOAL	Timer 0 auto load enable 1: Enable 0: Disable
3	TOAL_STATUS	Timer 0 auto load enable status 1: Enable 0: Disable
2:0	RESV0	Reserved

10000114 TOLMT_REG RISC Timer 0 Limit Register 0000000
0

Bit	31	30	29	28	27	26	25	24	23	22	21	20	19	18	17	16
Name	RESV0															
Type	RO															
Reset	0	0	0	0	0	0	0	0	0	0	0	0	0	0	0	0
Bit	15	14	13	12	11	10	9	8	7	6	5	4	3	2	1	0
Name	TOLMT															
Type	RW															
Reset	0	0	0	0	0	0	0	0	0	0	0	0	0	0	0	0

Bit(s)	Name	Description
31:16	RESV0	Reserved
15:0	TOLMT	Timer 0 Limit. When TOAL is set to 1, TOLMT will be loaded into timer 0 when timer 0 is enabled or when count down to 0.

10000118 T0_REG RISC Timer 0 Register 0000FFF
F

Bit	31	30	29	28	27	26	25	24	23	22	21	20	19	18	17	16
Name	RESV0															
Type	RO															
Reset	0	0	0	0	0	0	0	0	0	0	0	0	0	0	0	0
Bit	15	14	13	12	11	10	9	8	7	6	5	4	3	2	1	0
Name	T0															
Type	RW															
Reset	1	1	1	1	1	1	1	1	1	1	1	1	1	1	1	1

Bit(s)	Name	Description
31:16	RESV0	Reserved
15:0	T0	RISC down-count timer 0

10000120 WDTCTL_REG Watch Dog Timer Control Register 00000000

Bit	31	30	29	28	27	26	25	24	23	22	21	20	19	18	17	16
Name	WDTPRES															
Type	RW															
Reset	0	0	0	0	0	0	0	0	0	0	0	0	0	0	0	0
Bit	15	14	13	12	11	10	9	8	7	6	5	4	3	2	1	0
Name	RESV2							WDTEN	RESV1		WDTAL	WDTAL_STATUS	RESV0			
Type	RO							RW	RO		WO	RO	RO			
Reset	0	0	0	0	0	0	0	0	0	0	0	0	0	0	0	0

Bit(s)	Name	Description
31:16	WDTPRES	Watch dog timer count down tick pre-scale. Unit is 1u second.
15:8	RESV2	Reserved
7	WDTEN	Watch dog timer count down enable
6:5	RESV1	Reserved
4	WDTAL	Watch dog timer auto load enable 1: Enable 0: Disable
3	WDTAL_STATUS	Watch dog timer auto load enable status 1: Enable 0: Disable
2:0	RESV0	Reserved

10000124 WDTLMT_REG Watch Dog Timer Limit Register 00000000

Bit	31	30	29	28	27	26	25	24	23	22	21	20	19	18	17	16
Name	RESV0															
Type	RO															
Reset	0	0	0	0	0	0	0	0	0	0	0	0	0	0	0	0
Bit	15	14	13	12	11	10	9	8	7	6	5	4	3	2	1	0
Name	WDTLMT															
Type	RW															
Reset	0	0	0	0	0	0	0	0	0	0	0	0	0	0	0	0

Bit(s)	Name	Description
31:16	RESV0	Reserved
15:0	WDTLMT	Watch dog timer Limit. When WDTAL is set to 1, WDTLMT will be loaded into watch dog timer when watch dog timer is enabled or when count down to 0.

10000128 WDT_REG Watch Dog Timer Register 0000FFFF

Bit	31	30	29	28	27	26	25	24	23	22	21	20	19	18	17	16
Name	RESV0															
Type	RO															
Reset	0	0	0	0	0	0	0	0	0	0	0	0	0	0	0	0
Bit	15	14	13	12	11	10	9	8	7	6	5	4	3	2	1	0
Name	WDT															
Type	RW															
Reset	1	1	1	1	1	1	1	1	1	1	1	1	1	1	1	1

Bit(s)	Name	Description
31:16	RESV0	Reserved
15:0	WDT	watch dog timer.

10000130 **T1CTL_REG** **RISC Timer 1 Control Register** **0000000**
0

Bit	31	30	29	28	27	26	25	24	23	22	21	20	19	18	17	16
Name	T1PRES															
Type	RW															
Reset	0	0	0	0	0	0	0	0	0	0	0	0	0	0	0	0
Bit	15	14	13	12	11	10	9	8	7	6	5	4	3	2	1	0
Name	RESV2								T1EN	RESV1			T1AL	T1ALSTATUS	RESV0	
Type	RO								RW	RO			WO	RO	RO	
Reset	0	0	0	0	0	0	0	0	0	0	0	0	0	0	0	0

Bit(s)	Name	Description
31:16	T1PRES	Timer 1 count down tick pre-scale. Unit is 1u second.
15:8	RESV2	Reserved
7	T1EN	Timer 1 count down enable
6:5	RESV1	Reserved
4	T1AL	Timer 1 auto load enable 1: Enable 0: Disable
3	T1AL_STATUS	Timer 1 auto load enable status 1: Enable 0: Disable
2:0	RESV0	Reserved

10000134 **T1LMT_REG** **RISC Timer 1 Limit Register** **0000000**
0

Bit	31	30	29	28	27	26	25	24	23	22	21	20	19	18	17	16
Name	RESV0															
Type	RO															
Reset	0	0	0	0	0	0	0	0	0	0	0	0	0	0	0	0
Bit	15	14	13	12	11	10	9	8	7	6	5	4	3	2	1	0
Name	T1LMT															
Type	RW															
Reset	0	0	0	0	0	0	0	0	0	0	0	0	0	0	0	0

Bit(s)	Name	Description
31:16	RESV0	Reserved
15:0	T1LMT	Timer 1 Limit. When T1AL is set to 1, T1LMT will be loaded into timer 1 when timer 1 is enabled or when count down to 0.

10000138 **T1_REG** **RISC Timer 1 Register** **0000FFF**
F

Bit	31	30	29	28	27	26	25	24	23	22	21	20	19	18	17	16
Name	RESV0															
Type	RO															
Reset	0	0	0	0	0	0	0	0	0	0	0	0	0	0	0	0

Bit	15	14	13	12	11	10	9	8	7	6	5	4	3	2	1	0
Name	T1															
Type	RW															
Reset	1	1	1	1	1	1	1	1	1	1	1	1	1	1	1	1

Bit(s)	Name	Description
31:16	RESV0	Reserved
15:0	T1	RISC down-count timer 1

5.4 Interrupt Controller
5.4.1 Registers
CIRQ Changes LOG

Revision	Date	Author	Change Log
0.1	2012/6/15	YuShu Xiao	Initialization

Module name: CIRQ Base address: (+10000200h)

Address	Name	Width	Register Function
10000200	<u>IRQ_SEL0</u>	32	IRQ Selection 0 Register The registers allow the interrupt sources to be mapped onto interrupt requests IRQ. When write data to this register, the FIQ_SEL register will be update to the inverse data at the same time.
10000204	<u>IRQ_SEL1</u>	32	Reserved Reserved
10000208	<u>IRQ_SEL2</u>	32	Reserved Reserved
1000020C	<u>IRQ_SEL3</u>	32	Reserved Reserved
1000026C	<u>FIQ_SEL</u>	32	FIQ Selection Register The registers allow the interrupt sources to be mapped onto interrupt requests FIQ. When write data to this register, the IRQ_SEL0 register will be update to the inverse data at the same time.
10000270	<u>IRQ_MASK</u>	32	IRQ Mask Register This register contains a mask bit for each interrupt line in IRQ Controller.
10000274	<u>FIQ_MASK</u>	32	FIQ Mask Register This register contains a mask bit for each interrupt line in FIQ Controller
10000278	<u>IRQ_MASK_CLR</u>	32	IRQ Mask Clear Register This register is used to clear bits in IRQ Mask Register.
1000027C	<u>FIQ_MASK_CLR</u>	32	FIQ Mask Clear Register This register is used to clear bits in FIQ Mask Register.
10000280	<u>IRQ_MASK_SET</u>	32	IRQ Mask Set Register This register is used to set bits in the IRQ Mask Register.
10000284	<u>FIQ_MASK_SET</u>	32	FIQ Mask Set Register This register is used to set bits in the FIQ Mask Register.
10000288	<u>IRQ_EOI</u>	32	IRQ End of Interrupt Register This register provides a mean for software to relinquish and to refresh the interrupt controller. Writing a 1 to a specific bit results in an IRQ End of Interrupt command issued internally to the corresponding interrupt line.
1000028C	<u>FIQ_EOI</u>	32	FIQ End of Interrupt Register This register provides a mean for software to relinquish and to refresh the interrupt controller. Writing a 1 to a specific bit results in an FIQ End of Interrupt command issued internally to the corresponding interrupt line.
10000290	<u>IRQ_SENS</u>	32	IRQ Sensitive Register This register is used to set the IRQ interrupts as either edge or level sensitive.
10000294	<u>FIQ_SENS</u>	32	FIQ Sensitive Register This register is used to set the FIQ interrupts as either edge or level sensitive.
10000298	<u>INT_SOFT</u>	32	Software Interrupt Register

			Setting 1 to the specific bit position generates a software interrupt for corresponding interrupt line before interrupt input multiplex. This register is used for debug purpose.
1000029C	<u>IRQ_STAT</u>	32	IRQ Status Register Reading this register will get the IRQ interrupt sources with masking.
100002A0	<u>FIQ_STAT</u>	32	FIQ Status Register Reading this register will get the FIQ interrupt sources with masking.
100002A4	<u>INT_PURE</u>	32	Interrupt Pure Register Reading this register will get the pure interrupt sources without masking.
100002A8	<u>INT_MSEL</u>	32	Interrupt Mode Selection Register This register is used to select the interrupt modes of MIPS1004Kc.

10000200 **IRQ_SELO** **IRQ Selection 0 Register** **0000000**
1

Bit	31	30	29	28	27	26	25	24	23	22	21	20	19	18	17	16
Name	IRQ0[31:16]															
Type	RW															
Reset	0	0	0	0	0	0	0	0	0	0	0	0	0	0	0	0
Bit	15	14	13	12	11	10	9	8	7	6	5	4	3	2	1	0
Name	IRQ0[15:0]															
Type	RW															
Reset	0	0	0	0	0	0	0	0	0	0	0	0	0	0	0	1

Bit(s)	Name	Description
31:0	IRQ0	IRQ Selection 0 0: Clear IRQ_SELO and Set FIQ_SEL 1: Set IRQ_SELO and Clear FIQ_SEL

10000204 **IRQ_SEL1** **Reserved** **0000000**
0

Bit	31	30	29	28	27	26	25	24	23	22	21	20	19	18	17	16
Name	RESV[31:16]															
Type	RW															
Reset	0	0	0	0	0	0	0	0	0	0	0	0	0	0	0	0
Bit	15	14	13	12	11	10	9	8	7	6	5	4	3	2	1	0
Name	RESV[15:0]															
Type	RW															
Reset	0	0	0	0	0	0	0	0	0	0	0	0	0	0	0	0

Bit(s)	Name	Description
31:0	RESV	Reserved

10000208 **IRQ_SEL2** **Reserved** **0000000**
0

Bit	31	30	29	28	27	26	25	24	23	22	21	20	19	18	17	16
Name	RESV[31:16]															
Type	RW															
Reset	0	0	0	0	0	0	0	0	0	0	0	0	0	0	0	0
Bit	15	14	13	12	11	10	9	8	7	6	5	4	3	2	1	0
Name	RESV[15:0]															
Type	RW															
Reset	0	0	0	0	0	0	0	0	0	0	0	0	0	0	0	0

Bit(s)	Name	Description
31:0	RESV	Reserved

100020C **IRQ_SEL3** Reserved 0000000
0

Bit	31	30	29	28	27	26	25	24	23	22	21	20	19	18	17	16
Name	RESV[31:16]															
Type	RW															
Reset	0	0	0	0	0	0	0	0	0	0	0	0	0	0	0	0
Bit	15	14	13	12	11	10	9	8	7	6	5	4	3	2	1	0
Name	RESV[15:0]															
Type	RW															
Reset	0	0	0	0	0	0	0	0	0	0	0	0	0	0	0	0

Bit(s)	Name	Description
31:0	RESV	Reserved

100026C **FIQ_SEL** FIQ Selection Register 0000000
0

Bit	31	30	29	28	27	26	25	24	23	22	21	20	19	18	17	16
Name	FIQ[31:16]															
Type	RW															
Reset	0	0	0	0	0	0	0	0	0	0	0	0	0	0	0	0
Bit	15	14	13	12	11	10	9	8	7	6	5	4	3	2	1	0
Name	FIQ[15:0]															
Type	RW															
Reset	0	0	0	0	0	0	0	0	0	0	0	0	0	0	0	0

Bit(s)	Name	Description
31:0	FIQ	FIQ Selection 0: Clear FIQ_SEL and Set IRQ_SELO 1: Set FIQ_SEL and Clear IRQ_SELO

1000270 **IRQ_MASK** IRQ Mask Register 0000000
0

Bit	31	30	29	28	27	26	25	24	23	22	21	20	19	18	17	16
Name	IRQ0[31:16]															
Type	RW															
Reset	0	0	0	0	0	0	0	0	0	0	0	0	0	0	0	0
Bit	15	14	13	12	11	10	9	8	7	6	5	4	3	2	1	0
Name	IRQ0[15:0]															
Type	RW															
Reset	0	0	0	0	0	0	0	0	0	0	0	0	0	0	0	0

Bit(s)	Name	Description
31:0	IRQ0	IRQ Mask 0: Interrupt is disabled 1: Interrupt is enabled

1000274 **FIQ_MASK** FIQ Mask Register 0000000
0

Bit	31	30	29	28	27	26	25	24	23	22	21	20	19	18	17	16
-----	----	----	----	----	----	----	----	----	----	----	----	----	----	----	----	----

Name	FIQ[31:16]															
Type	RW															
Reset	0	0	0	0	0	0	0	0	0	0	0	0	0	0	0	0
Bit	15	14	13	12	11	10	9	8	7	6	5	4	3	2	1	0
Name	FIQ[15:0]															
Type	RW															
Reset	0	0	0	0	0	0	0	0	0	0	0	0	0	0	0	0

Bit(s)	Name	Description
31:0	FIQ	FIQ Mask 0: Interrupt is disabled 1: Interrupt is enabled

10000278 IRQ_MASK_C **IRQ Mask Clear Register** 0000000
LR 0

Bit	31	30	29	28	27	26	25	24	23	22	21	20	19	18	17	16
Name	IRQ0[31:16]															
Type	WO															
Reset	0	0	0	0	0	0	0	0	0	0	0	0	0	0	0	0
Bit	15	14	13	12	11	10	9	8	7	6	5	4	3	2	1	0
Name	IRQ0[15:0]															
Type	WO															
Reset	0	0	0	0	0	0	0	0	0	0	0	0	0	0	0	0

Bit(s)	Name	Description
31:0	IRQ0	IRQ Mask Clear 0: No effect 1: Clear the corresponding MASK bit

1000027C FIQ_MASK_C **FIQ Mask Clear Register** 0000000
LR 0

Bit	31	30	29	28	27	26	25	24	23	22	21	20	19	18	17	16
Name	FIQ[31:16]															
Type	WO															
Reset	0	0	0	0	0	0	0	0	0	0	0	0	0	0	0	0
Bit	15	14	13	12	11	10	9	8	7	6	5	4	3	2	1	0
Name	FIQ[15:0]															
Type	WO															
Reset	0	0	0	0	0	0	0	0	0	0	0	0	0	0	0	0

Bit(s)	Name	Description
31:0	FIQ	FIQ Mask Clear 0: No effect 1: Clear the corresponding MASK bit

10000280 IRQ_MASK_S **IRQ Mask Set Register** 0000000
ET 0

Bit	31	30	29	28	27	26	25	24	23	22	21	20	19	18	17	16
Name	IRQ0[31:16]															
Type	WO															
Reset	0	0	0	0	0	0	0	0	0	0	0	0	0	0	0	0
Bit	15	14	13	12	11	10	9	8	7	6	5	4	3	2	1	0
Name	IRQ0[15:0]															
Type	WO															
Reset	0	0	0	0	0	0	0	0	0	0	0	0	0	0	0	0

Bit(s)	Name	Description
31:0	IRQ0	IRQ Mask Set 0: No effect 1: Set the corresponding MASK bit

1000284 **FIQ_MASK_S** **FIQ Mask Set Register** 0000000
ET 0

Bit	31	30	29	28	27	26	25	24	23	22	21	20	19	18	17	16
Name	FIQ[31:16]															
Type	WO															
Reset	0	0	0	0	0	0	0	0	0	0	0	0	0	0	0	0
Bit	15	14	13	12	11	10	9	8	7	6	5	4	3	2	1	0
Name	FIQ[15:0]															
Type	WO															
Reset	0	0	0	0	0	0	0	0	0	0	0	0	0	0	0	0

Bit(s)	Name	Description
31:0	FIQ	FIQ Mask Set 0: No effect 1: Set the corresponding MASK bit

1000288 **IRQ_EOI** **IRQ End of Interrupt Register** 0000000
0

Bit	31	30	29	28	27	26	25	24	23	22	21	20	19	18	17	16
Name	IRQ0[31:16]															
Type	W1C															
Reset	0	0	0	0	0	0	0	0	0	0	0	0	0	0	0	0
Bit	15	14	13	12	11	10	9	8	7	6	5	4	3	2	1	0
Name	IRQ0[15:0]															
Type	W1C															
Reset	0	0	0	0	0	0	0	0	0	0	0	0	0	0	0	0

Bit(s)	Name	Description
31:0	IRQ0	IRQ End of Interrupt 0: No service is currently in progress or pending 1: Interrupt request is in-service

100028C **FIQ_EOI** **FIQ End of Interrupt Register** 0000000
0

Bit	31	30	29	28	27	26	25	24	23	22	21	20	19	18	17	16
Name	FIQ[31:16]															
Type	W1C															
Reset	0	0	0	0	0	0	0	0	0	0	0	0	0	0	0	0
Bit	15	14	13	12	11	10	9	8	7	6	5	4	3	2	1	0
Name	FIQ[15:0]															
Type	W1C															
Reset	0	0	0	0	0	0	0	0	0	0	0	0	0	0	0	0

Bit(s)	Name	Description
31:0	FIQ	FIQ End of Interrupt 0: No service is currently in progress or pending 1: Interrupt request is in-service

**10000290 IRQ_SENS IRQ Sensitive Register 0000000
1**

Bit	31	30	29	28	27	26	25	24	23	22	21	20	19	18	17	16
Name	IRQ0[31:16]															
Type	RW															
Reset	0	0	0	0	0	0	0	0	0	0	0	0	0	0	0	0
Bit	15	14	13	12	11	10	9	8	7	6	5	4	3	2	1	0
Name	IRQ0[15:0]															
Type	RW															
Reset	0	0	0	0	0	0	0	0	0	0	0	0	0	0	0	1

Bit(s)	Name	Description
31:0	IRQ0	IRQ Sensitive 0: Edge sensitivity with Pos-edge Edge 1: Level sensitivity with active High

**10000294 FIQ_SENS FIQ Sensitive Register 0000000
1**

Bit	31	30	29	28	27	26	25	24	23	22	21	20	19	18	17	16
Name	FIQ[31:16]															
Type	RW															
Reset	0	0	0	0	0	0	0	0	0	0	0	0	0	0	0	0
Bit	15	14	13	12	11	10	9	8	7	6	5	4	3	2	1	0
Name	FIQ[15:0]															
Type	RW															
Reset	0	0	0	0	0	0	0	0	0	0	0	0	0	0	0	1

Bit(s)	Name	Description
31:0	FIQ	FIQ Sensitive 0: Edge sensitivity with Pos-edge Edge 1: Level sensitivity with active High

**10000298 INT_SOFT Software Interrupt Register 0000000
0**

Bit	31	30	29	28	27	26	25	24	23	22	21	20	19	18	17	16
Name	INT[31:16]															
Type	RW															
Reset	0	0	0	0	0	0	0	0	0	0	0	0	0	0	0	0
Bit	15	14	13	12	11	10	9	8	7	6	5	4	3	2	1	0
Name	INT[15:0]															
Type	RW															
Reset	0	0	0	0	0	0	0	0	0	0	0	0	0	0	0	0

Bit(s)	Name	Description
31:0	INT	Software Interrupt

**1000029C IRQ_STAT IRQ Status Register 0000000
0**

Bit	31	30	29	28	27	26	25	24	23	22	21	20	19	18	17	16
Name	IRQ0[31:16]															
Type	RO															
Reset	0	0	0	0	0	0	0	0	0	0	0	0	0	0	0	0
Bit	15	14	13	12	11	10	9	8	7	6	5	4	3	2	1	0
Name	IRQ0[15:0]															
Type	RO															
Reset	0	0	0	0	0	0	0	0	0	0	0	0	0	0	0	0

Bit(s)	Name	Description
31:0	IRQ0	IRQ Status 0: No interrupt request is generated 1: Interrupt request is pending

100002A0 **FIQ_STAT** **FIQ Status Register** **0000000**
0

Bit	31	30	29	28	27	26	25	24	23	22	21	20	19	18	17	16
Name	FIQ[31:16]															
Type	RO															
Reset	0	0	0	0	0	0	0	0	0	0	0	0	0	0	0	0
Bit	15	14	13	12	11	10	9	8	7	6	5	4	3	2	1	0
Name	FIQ[15:0]															
Type	RO															
Reset	0	0	0	0	0	0	0	0	0	0	0	0	0	0	0	0

Bit(s)	Name	Description
31:0	FIQ	FIQ Status 0: No interrupt request is generated 1: Interrupt request is pending

100002A4 **INT_PURE** **Interrupt Pure Register** **0000000**
0

Bit	31	30	29	28	27	26	25	24	23	22	21	20	19	18	17	16
Name	INT[31:16]															
Type	RO															
Reset	0	0	0	0	0	0	0	0	0	0	0	0	0	0	0	0
Bit	15	14	13	12	11	10	9	8	7	6	5	4	3	2	1	0
Name	INT[15:0]															
Type	RO															
Reset	0	0	0	0	0	0	0	0	0	0	0	0	0	0	0	0

Bit(s)	Name	Description
31:0	INT	Pure Interrupt 0: No interrupt source is asserted 1: Interrupt source is asserted

100002A8 **INT_MSEL** **Interrupt Mode Selection Register** **0000000**
0

Bit	31	30	29	28	27	26	25	24	23	22	21	20	19	18	17	16	
Name	RESV[30:15]																
Type	RW																
Reset	0	0	0	0	0	0	0	0	0	0	0	0	0	0	0	0	
Bit	15	14	13	12	11	10	9	8	7	6	5	4	3	2	1	0	
Name	RESV[14:0]															SEL	
Type	RW															RW	
Reset	0	0	0	0	0	0	0	0	0	0	0	0	0	0	0	0	0

Bit(s)	Name	Description
31:1	RESV	Reserved
0	SEL	Interrupt Mode Selection 0: Compatibility & Vectored Interrupt Mode 1: External Interrupt Controller Mode

5.5 EMC Controller

5.5.1 Register

EXT_MC_ARB Changes LOG

Revision	Date	Author	Change Log
0.1	2012/10/5	Lancelot	Initialization
0.2	2013/8/19	YS Xiao	Modify to MT7628

Module name: EXT_MC_ARB Base address: (+10000300h)

Address	Name	Width	Register Function
10000300	<u>SDRAM_CFG0</u>	32	SDRAM Configuration 0
10000304	<u>SDRAM_CFG1</u>	32	SDRAM Configuration 1
10000308	<u>ILL_ACC_ADDR</u>	32	Illegal Access Address Capture
1000030C	<u>ILL_ACC_TYPE</u>	32	Illegal Access Type Capture
10000310	<u>DDR_SELF_REFRESH</u>	32	ODT and Self-Refresh Configuration
10000314	<u>SDR_DDR_PWR_SAVE_CNT</u>	32	Self-Refresh Time Count
10000320	<u>DLL_DBG</u>	32	DRAM DLL Debug Probe
10000340	<u>DDR_CFG0</u>	32	DDR1/DDR2 controller configuration 0 register
10000344	<u>DDR_CFG1</u>	32	DDR1/DDR2 controller configuration 1 register
10000348	<u>DDR_CFG2</u>	32	DDR1/DDR2 controller configuration 2 register
1000034C	<u>DDR_CFG3</u>	32	DDR1/DDR2 controller configuration 3 register
10000350	<u>DDR_CFG4</u>	32	DDR1/DDR2 controller configuration 4 register
10000360	<u>DDR_DQ_DLY</u>	32	DDR1/DDR2 DQ delay control register
10000364	<u>DDR_DQS_DLY</u>	32	DDR1/DDR2 DQS delay control register
10000368	<u>DDR_DLL_SLV</u>	32	DDR1/DDR2 DLL slave control register
1000036C	<u>DDR_DLL_MST</u>	32	DDR1/DDR2 DLL master control register
10000380	<u>MC_ARB_CFG</u>	32	MC 2 to 1 arbiter setting
10000384	<u>MC_AG_BW</u>	32	MC Channel BW/QoS_Type/DueDate Setting
10000390	<u>RB_DBG</u>	32	RB Debug
10000394	<u>RB_STATE</u>	32	RB Debug State
10000398	<u>RB_BW</u>	32	RB Bandwidth
1000039C	<u>RB_LAT</u>	32	RB Latency

10000300 SDRAM_CFG0 SDRAM Configuration 0
**5192528
2**

Bit	31	30	29	28	27	26	25	24	23	22	21	20	19	18	17	16
Name	DIS_CLK_GT	CLK_SLEW		TWR	TMRD				TRFC				RSV0		TCAS	
Type	RW	RW		RW	RW				RW				RO		RW	
Reset	0	1	0	1	0	0	0	1	1	0	0	1	0	0	1	0
Bit	15	14	13	12	11	10	9	8	7	6	5	4	3	2	1	0
Name	TRAS			RSV1		TRCD		TRC				RSV2		TRP		
Type	RW			RO		RW		RW				RO		RW		
Reset	0	1	0	1	0	0	1	0	1	0	0	0	0	0	1	0

Bit(s)	Name	Description
31	DIS_CLK_GT	Disable Clock Gating Disables clock gating of the SDR DRAM controller. 0: Enable 1: Disable
30:29	CLK_SLEW	Reserved
28	TWR	Write Recovery Time (unit: system clock cycles - 1)
27:24	TMRD	Load Mode Register command to any other command delay. (unit: system clock cycles - 1)
23:20	TRFC	Auto Refresh period (unit: system clock cycles - 1)
19:18	RSV0	Reserved
17:16	TCAS	CAS Latency Time (unit: system clock cycles - 1)
15:12	TRAS	The Active To Precharge command delay. (unit: system clock cycles - 1)
11:10	RSV1	Reserved
9:8	TRCD	Active To Read or Write delay (RAS to CAS delay) (unit: system clock cycles - 1)
7:4	TRC	Active To Active command period (unit: system clock cycles - 1)
3:2	RSV2	Reserved
1:0	TRP	Precharge command period (unit: system clock cycles - 1)

1000304 SDRAM_CFG1 SDRAM Configuration 1

0112060
0

Bit	31	30	29	28	27	26	25	24	23	22	21	20	19	18	17	16
Name	SDRAM_INIT_STRT	SDRAM_INIT_DONE	RBC_MAPPING	PWR_DOWN_EN	PWR_DOWN_EN	RSV0		SDRAM_WIDTH	RSV1		NUMCOLS		RSV2		NUMROWS	
Type	RW	RO	RW	RW	RW	RO		RW	RO		RW		RO		RW	
Reset	0	0	0	0	0	0	0	1	0	0	0	1	0	0	1	0
Bit	15	14	13	12	11	10	9	8	7	6	5	4	3	2	1	0
Name	TREFR															
Type	RW															
Reset	0	0	0	0	0	1	1	0	0	0	0	0	0	0	0	0

Bit(s)	Name	Description
31	SDRAM_INIT_START	SDRAM Initialization Start performs the SDRAM initialization sequence. Can not set this bit to 0 after initialization. 1: Start initialization
30	SDRAM_INIT_DONE	SDRAM Initialization Done Indicates the SDRAM has been initialized. 0: Not initialized. 1: Initialized.
29	RBC_MAPPING	RBC Mapping Selects the address mapping scheme. 0: {BANK ADDR, ROW ADDR, COL ADDR} address mapping scheme 1: {ROW ADDR, BANK ADDR, COL ADDR} address mapping scheme
28	PWR_DOWN_EN	Power Down Enable Enables the SDRAM precharge power-down mode to save standby power.

Bit(s)	Name	Description
27	PWR_DOWN_MODE	<p>0: Disable 1: Enable</p> <p>Power Down Mode 0: Precharge power down mode 1: Active power down</p>
26:25	RSV0	Reserved
24	SDRAM_WIDTH	<p>SDRAM Width Selects the number of SDRAM data bus bits. 0: 16 bits 1: 32 bits</p>
23:22	RSV1	Reserved
21:20	NUMCOLS	<p>Number of Columns Selects the number of column address bits. 0: 8 Column address bits 1: 9 Column address bits (default) 2: 10 Column address bits 3: 11 Column address bits</p>
19:18	RSV2	Reserved
17:16	NUMROWS	<p>Number of Rows Selects the number of row address bits. 0: 11 Row address bits 1: 12 Row address bits (default) 2: 13 Row address bits 3: 14 Row address bits</p>
15:0	TREFR	<p>AUTO REFRESH period (unit: SDRAM clock cycles - 1).</p>

10000308 ILL_ACC_ADDR **Illegal Access Address Capture** 0000000
0

Bit	31	30	29	28	27	26	25	24	23	22	21	20	19	18	17	16
Name	ILL_ACC_ADDR[31:16]															
Type	RO															
Reset	0	0	0	0	0	0	0	0	0	0	0	0	0	0	0	0
Bit	15	14	13	12	11	10	9	8	7	6	5	4	3	2	1	0
Name	ILL_ACC_ADDR[15:0]															
Type	RO															
Reset	0	0	0	0	0	0	0	0	0	0	0	0	0	0	0	0

Bit(s)	Name	Description
31:0	ILL_ACC_ADDR	<p>Illegal Access Address if any bus masters (including CPU) issue illegal accesses (e.g. accesses to reserved memory space, or non-double-word accesses to configuration registers), the address of the illegal transaction is captured in this register.</p> <p>An illegal interrupt is generated to indicate this exception.</p>

1000030C ILL_ACC_TYPE **Illegal Access Type Capture** 0000000
0

Bit	31	30	29	28	27	26	25	24	23	22	21	20	19	18	17	16
Name	ILL_IN_TATUS	ILL_ACC_WR	RSV0										ILL_ACC_BSEL			
Type	W1C	RO	RO										RO			
Reset	0	0	0	0	0	0	0	0	0	0	0	0	0	0	0	0
Bit	15	14	13	12	11	10	9	8	7	6	5	4	3	2	1	0

Name	RSV1					ILL_IID			ILL_ACC_LEN								
Type	RO					RO			RO								
Reset	0	0	0	0	0	0	0	0	0	0	0	0	0	0	0	0	0

Bit(s)	Name	Description
31	ILL_INT_STATUS	Illegal Access Interrupt Status Indicates whether the illegal access interrupt is cleared or pending. Read 0: Cleared 1: Pending Write 1: Clear both the ILL_ACC_ADDR and ILL_ACC_TYPE registers and thus clear ILL_INT_STATUS.
30	ILL_ACC_WR	Illegal Access Write Indicates the illegal access is a read or a write. 0: A read access 1: A write access
29:20	RSV0	Reserved
19:16	ILL_ACC_BSEL	Illegal Access Byte Select Indicates which bytes were illegally accessed.
15:11	RSV1	Reserved
10:8	ILL_IID	Illegal Access Initiator ID Indicates the initiator ID of the illegal access. 0: CPU 1: DMA 2: PPE 3: Ethernet PDMA Rx 4: Ethernet PDMA Tx 5: PCI/PCIE 6: Embedded WLAN MAC/BBP 7: USB
7:0	ILL_ACC_LEN	Illegal Access Length Indicates the access size of the illegal access. (unit: bytes)

10000310 DDR_SELF_REFRESH ODT and Self-Refresh Configuration 0E12000
1

Bit	31	30	29	28	27	26	25	24	23	22	21	20	19	18	17	16
Name	RSV0				ODT_SRC_SEL				ODT_OFF_DLY				ODT_ON_DLY			
Type	RO				RW				RW				RW			
Reset	0	0	0	0	1	1	1	0	0	0	0	1	0	0	1	0
Bit	15	14	13	12	11	10	9	8	7	6	5	4	3	2	1	0
Name	RSV1											SR_AU TO_EN	RSV2		SR AC K_B	SR RE Q_B
Type	RO											RW	RO		RO	RW
Reset	0	0	0	0	0	0	0	0	0	0	0	0	0	0	0	1

Bit(s)	Name	Description
31:28	RSV0	Reserved
27:24	ODT_SRC_SEL	ODT Source Select Sets the DDR pad ODT control source. 0: Dasavtive[0] 1: Dasavtive[1] ... 11: Dasavtive[11] 12: DQS_WINDOW 13: ODT_LOCAL 14: Always on 15: Always off

Bit(s)	Name	Description
23:20	ODT_OFF_DLY	ODT Off Delay Sets the delay time of the ODT_OFF signal based on the ODT_ON signal. 0: 0 T 1: 0.5 T 2: 1.5 T 3: 2.5 T ... 15: 14.5 T
19:16	ODT_ON_DLY	ODT On Delay Sets the delay time of the ODT_ON signal based on the ODT source signal. 0: 0 T 1: 1 T 2: 2 T ... 15: 15 T
15:5	RSV1	Reserved
4	SR_AUTO_EN	Auto Self-Refresh Enable Enables auto self-refresh for power saving. 0: Disable 1: Enable
3:2	RSV2	Reserved
1	SRACK_B	Self-Refresh Acknowledge Status Indicates whether DDR2 is in self-refresh mode or has exited from self-refresh mode. When DDR2 changes from self-refresh mode to normal mode, it takes about 200 clock cycles. 0: The DDR2 is in self-refresh mode. 1: The DDR2 has exited from self-refresh mode.
0	SRREQ_B	Self-Refresh Request Control Requests DDR2 to enter or exit self-refresh mode. It is low active. 0: Enter self-refresh mode. 1: Exit self-refresh mode.

1000314 SDR DDR P WR SAVE C **Self-Refresh Time Count** 0003FFF
NT F

Bit	31	30	29	28	27	26	25	24	23	22	21	20	19	18	17	16
Name	PD_CNT								SR_TAR_CNT[23:16]							
Type	RO								RW							
Reset	0	0	0	0	0	0	0	0	0	0	0	0	0	0	1	1
Bit	15	14	13	12	11	10	9	8	7	6	5	4	3	2	1	0
Name	SR_TAR_CNT[15:0]															
Type	RW															
Reset	1	1	1	1	1	1	1	1	1	1	1	1	1	1	1	1

Bit(s)	Name	Description
31:24	PD_CNT	Power Down Count Counts the times self-refresh mode is entered
23:0	SR_TAR_CNT	Self-Refresh Time Count This counter is only referenced when the SDR (PWR_DOWN_EN) or DDR (SR_AUTO_EN) is set. This counter measures the period SDR or DDR is in IDLE status. When the IDLE period has reached the specified time period, the SDR or DDR automatically enter power-saving or selfrefresh mode. Use the following equations to configure the counter. DRAM_CLK_FREQ is PLL_CLK (600 MHz) divided by 3 DDR: (SR_TAR_CNT * 256 + 255) / DRAM_CLK_FREQ SDR: (SR_TAR_CNT * 256) / DRAM_CLK_FREQ

Bit(s)	Name	Description
		DDR reference table 200 MHz: (32'h03FFFF * 256 + 255) * 5 ns ~ = 335 ms SDRAM reference table 120 MHz: 32'h03FFFF * 256 * 8.3 ns ~ = 560 ms

10000320 **DLL_DBG** DRAM DLL Debug Probe 0000000
0

Bit	31	30	29	28	27	26	25	24	23	22	21	20	19	18	17	16
Name	RSV0												RSV1		TDC_STABLE[5:4]	
Type	RO												RO		RO	
Reset	0	0	0	0	0	0	0	0	0	0	0	0	0	0	0	0
Bit	15	14	13	12	11	10	9	8	7	6	5	4	3	2	1	0
Name	TDC_STABLE[3:0]				MST_DLY_SEL								RSV2	CURR_STATE		ADLL_LOCK_DONE
Type	RO				RO								RO	RO		RO
Reset	0	0	0	0	0	0	0	0	0	0	0	0	0	0	0	0

Bit(s)	Name	Description
31:20	RSV0	Reserved
19:18	RSV1	Reserved
17:12	TDC_STABLE	ADLL master coarse-grain delay code
11:4	MST_DLY_SEL	ADLL master final delay code
3	RSV2	Reserved
2:1	CURR_STATE	ADLL controller FSM current state
0	ADLL_LOCK_DONE	ADLL lock done signal

10000340 **DDR_CFG0** DDR1/DDR2 controller configuration 0 register 249B425
B

Bit	31	30	29	28	27	26	25	24	23	22	21	20	19	18	17	16
Name	T_RRD				T_RAS				T_RP				T_RFC[5:3]			
Type	RW				RW				RW				RW			
Reset	0	0	1	0	0	1	0	0	1	0	0	1	1	0	1	1
Bit	15	14	13	12	11	10	9	8	7	6	5	4	3	2	1	0
Name	T_RFC[2:0]				T_REFI											
Type	RW				RW											
Reset	0	1	0	0	0	0	1	0	0	1	0	1	1	0	1	1

Bit(s)	Name	Description
31:28	T_RRD	The minimum number of clock cycles from an active command to the next active command for different banks (TRRD). For DDR2 devices, this is required to be a minimum of 2 regardless of the cycle time.
27:23	T_RAS	The number of clock cycles from an active command until a pre-charge command is allowed. To obtain this value, one should divide the minimum RAS# to pre-charge delay of the SDRAM by the clock cycle time (TRAS). The sum of Active-to-Pre-charge and Pre-charge-to-Active should be equal or larger than active-to-active delay of the same bank (TRC)
22:19	T_RP	The number of clock cycles needed for the SDRAM to recover from a pre-charge command and ready to accept the next active command. To obtain this value, one should divide the RAS# pre-charge time of the SDRAM (TRP) by the clock cycle time. The sum of Active-to-Pre-charge

Bit(s)	Name	Description
18:13	T_RFC	and Pre-charge-to-Active should be equal or larger than active-to-active delay of the same bank (TRC) Half the number of clock cycles needed for the SDRAM to recover from a refresh signal to be ready to take the next command. To obtain this value, one should divide the SDRAM row cycle time (TRFC) by the clock cycle time.
12:0	T_REFI	The number of clock cycles from one refresh command to the next refresh command. To obtain this value, one should divide the periodic refresh interval (TREFI) by the clock cycle time. The actual timing of issuing a pre-charge command may be delayed by if the SDRAM is processing a normal access. However, the delay is not accumulative so there is no need to shorten the refresh interval to account for memory access time. The non-accumulative refresh delay typically increases memory bandwidth by a few percentage points.

10000344 DDR_CFG1

DDR1/DDR2 controller configuration 1 register

222E242
4

Bit	31	30	29	28	27	26	25	24	23	22	21	20	19	18	17	16
Name	T_WTR				T_RTP				RSV0		US ER_ DA TA_ WID TH	IND_SDRAM_SIZ E		IND_SDR AM_ WID TH		
Type	RW				RW				RO		RW	RW		RW		
Reset	0	0	1	0	0	0	1	0	0	0	1	0	1	1	1	0
Bit	15	14	13	12	11	10	9	8	7	6	5	4	3	2	1	0
Name	EXT_BAN K		TOTAL_SD RAM_WID TH		T_WR				T_MRD			T_RCD				
Type	RW		RW		RW				RW			RW				
Reset	0	0	1	0	0	1	0	0	0	0	1	0	0	1	0	0

Bit(s)	Name	Description
31:28	T_WTR	The write-to-read delay (TWTR) (last write data to the next read command) as specified by the DDR2 data sheet
27:24	T_RTP	The read-to-pre-charge delay (TRTP) as specified by the DDR2 data sheet. Note that this is a DDR2 requirement, and requires a minimum of 2 cycles. These bits are ignored in DDR mode.
23:22	RSV0	Reserved
21	USER_DATA_WIDTH	Specify user data width 0: 32-bit 1: 64-bit When user data width is 32-bit, total SDRAM width (bit[13:12]) must be 10. NOTE: This system is always 64-bit. Please do not modify this setting.
20:18	IND_SDRAM_SIZE	Specify individual SRAM size 000: Reserved 001: Individual SDRAM is 64 Mbit, (DDR only) 010: Individual SDRAM is 128 Mbit, (DDR only) 011: Individual SDRAM is 256 Mbit. 100: Individual SDRAM is 512 Mbit. 101: Individual SDRAM is 1 Gbit. 110: Individual SDRAM is 2 Gbit, (DDR2 only). 111: Reserved
17:16	IND_SDRAM_WIDTH	Specify individual SRAM data width 00: Reserved 01: 8-bit. 10: 16-bit. 11: Reserved
15:14	EXT_BANK	Specify bank/module configuration 00: 1 external bank, 1 module. (CS#[0])

Bit(s)	Name	Description
13:12	TOTAL_SDRAM_WIDTH	01: 2 external bank, 1 module. (CS#[1:0]), 10: Reserved 11: 2 external banks, 2 modules. (CS#[1:0]) NOTE: only one CS pin. This field specifies the total data width to the SDRAM. For example, if four 8-bit wide DDR2 chips are used in parallel to form a 32-bit DDR2 data width, this field should be defined as 11 to indicate a 32-bit width. In this case, bit[17:16] should be defined as 01. 00: Reserved 01: Reserved 10: 16-bit 11: 32-bit. Allowed only when user data width is 64-bit (bit21 is 1).
11:8	T_WR	The clock cycles needed for the DDR to recover from a write command and be able to accept a pre-charge command. To obtain this value, divide the SDRAM write recovery time by the clock cycle time (TWR)
7:4	T_MRD	The number of clock cycles after the setting of the mode registers in the DDR and before the issue of the next command. To obtain this value, divide the Mode Register Set Cycle time (TMRD) by the clock cycle time.
3:0	T_RCD	The number of clock cycles from an active command to a read/write assertion. To obtain this value, divide the RAS# to CAS# delay time (TRCD) by the clock cycle time.

10000348 DDR_CFG2 DDR1/DDR2 controller configuration 2 register 43FFE44
3

Bit	31	30	29	28	27	26	25	24	23	22	21	20	19	18	17	16
Name	REGE	DDR2_MODE	DQS0_GATING_WINDOW		DQS1_GATING_WINDOW		RSV0[12:3]									
Type	RW	RW	RW		RW		RO									
Reset	0	1	0	0	0	0	1	1	1	1	1	1	1	1	1	1
Bit	15	14	13	12	11	10	9	8	7	6	5	4	3	2	1	0
Name	RSV0[2:0]		PD	WR			DLLRESET	TESTMODE	CAS_LATENCY			BURST_TYPE	BURST_LENGTH			
Type	RO		RW	RW			RW	RW	RW			RO	RW			
Reset	1	1	1	0	0	1	0	0	0	1	0	0	0	0	1	1

Bit(s)	Name	Description
31	REGE	This bit should be high when external registers are inserted in the controller and address signals are sent between the controller and the DDR SDRAM. One example of such instance is when register mode SDRAM DIMM is used. This bit should be low when the control and address signals from the controller is connected to the SDRAM without register delay.
30	DDR2_MODE	This bit determines whether the memory controller is in DDR1 or DDR2 mode. 0: DDR1 mode 1: DDR2 mode
29:28	DQS0_GATING_WINDOW	Controls the mask for the data strobe 0 (DQS0) window leading and trailing edge. 00: Half extended cycle for the leading and trailing edge of DQS window (maximum window) 01: Only half extended cycle for leading edge of DQS window 10: Only half extended cycle for trailing edge of DQS window 11: No extended cycle for leading and trailing edge of DQS window (minimum window)
27:26	DQS1_GATING_WINDOW	Controls the mask for the data strobe 1 DQS1 window leading and trailing edge.

Bit(s)	Name	Description
		00: Half extended cycle for the leading and trailing edge of DQS window (maximum window) 01: Only half extended cycle for leading edge of DQS window 10: Only half extended cycle for trailing edge of DQS window 11: No extended cycle for leading and trailing edge of DQS window (minimum window)
25:13	RSV0	Reserved
12	PD	Active Memory Power Down Exit Time 0: Fast exit time (TXARD) 1: Slow exit time(TXARDS) This bit is used for DDR2 only. This bit must be 0 for DDR1.
11:9	WR	Auto Pre-charge Write Recovery (TDAL) These bits must be 0 for DDR1.
8	DLLRESET	SDRAM Delay Locked Loop (DLL) Reset 0: Normal operation 1: Normal operation with DLL reset
7	TESTMODE	Set SDRAM to run test mode. 0: Normal operation. 1: Test mode. The user must keep this bit at 0 if SDRAM does not support TESTMODE bit.
6:4	CAS_LATENCY	Specifies the number of the clock cycles from the assertion of a read/write signal to the SDRAM until the first valid data on the output from the SDRAM. The valid numbers are: 101: 1.5 for DDR1 or 5 for DDR2. 010: 2 110: 2.5 (DDR1 only) 011: 3 100: 4 (DDR2 only)
3	BURST_TYPE	This register is hardwired to 0 to indicate a sequential burst type.
2:0	BURST_LENGTH	Indicates the burst length of the read/write transaction. 010: 4 bursts 011: 8 bursts NOTE: 1. A burst of 4 is not allowed when user data is 64-bit while SDRAM data is 16-bit. 2. A burst of 8 is allowed in all user/SDRAM data width combination. 3. Other values for burst length are not allowed.

1000034C DDR_CFG3 DDR1/DDR2 controller configuration 3 register FFFFE41
2

Bit	31	30	29	28	27	26	25	24	23	22	21	20	19	18	17	16
Name	RSV0[18:3]															
Type	RO															
Reset	1	1	1	1	1	1	1	1	1	1	1	1	1	1	1	1
Bit	15	14	13	12	11	10	9	8	7	6	5	4	3	2	1	0
Name	RSV0[2:0]			Q_OF	RD_OS	DIS_DI_FF_DQ_S	OCD			RTT_1	ADDITIVE_LATENCY		RTT_0	DS	DLL	
Type	RO			RW	RW	RW	RW			RW	RW		RW	RW	RW	
Reset	1	1	1	0	0	1	0	0	0	0	0	1	0	0	1	0

Bit(s)	Name	Description
31:13	RSV0	Reserved
12	Q_OFF	Output Buffer Disable 0: Enabled 1: Disabled This bit is used for DDR2 only. This bit must be 0 for DDR1.

Bit(s)	Name	Description
11	RDOS	Redundant Data Strobe (DQS) This bit enables the redundant DQS function if supported by the SDRAM. 0: Disable 1: Enable This bit is used for DDR2 only and must be 0 for DDR1.
10	DIS_DIFF_DQS	Disable differential DQS 0: Enable 1: Disable This bit is used for DDR2 only and must be 0 for DDR1.
9:7	OCD	Off-Chip Driver Impedance Calibration (OCD) These bits support the OCD function if supported by the SDRAM. The value programmed in these register bits will be programmed into the SDRAM at EMR1 programming. Settings are vendor-dependant.
6	RTT1	Internal Termination Resistor (RTT) bit 1 Used together with bit 2 (RTT0) to control On-Die Termination (ODT). Combine values for (RTT1, RTT0) to select ODT settings. 00: ODT disabled. 01: 75 ohm 10: 150 ohm 11: Reserved This bit is used for DDR2 only and must be 0 for DDR1.
5:3	ADDITIVE_LATENCY	Additive Latency 000: 0 cycle 001: 1 cycle 010: 2 cycles 011: 3 cycles 100: 4 cycles 101: 5 cycles Others: Reserved This bit is used for DDR2 only and must be 0 for DDR1.
2	RTT0	Internal Termination Resistor (RTT) bit 0 Used together with bit 6 (RTT1) to control ODT. This bit is used for DDR2 only and must be 0 for DDR1.
1	DS	SDRAM drive Strength 0: 100% drive strength. 1: 60% drive strength.
0	DLL	SDRAM Delay Locked Loop (DLL) Enable 0: Disable 1: Enable

10000350 **DDR_CFG4** DDR1/DDR2 controller configuration 4 register FFFFFF
F4

Bit	31	30	29	28	27	26	25	24	23	22	21	20	19	18	17	16
Name	RSV0[26:11]															
Type	RO															
Reset	1	1	1	1	1	1	1	1	1	1	1	1	1	1	1	1
Bit	15	14	13	12	11	10	9	8	7	6	5	4	3	2	1	0
Name	RSV0[10:0]											FAW				
Type	RO											RW				
Reset	1	1	1	1	1	1	1	1	1	1	1	1	0	1	0	0

Bit(s)	Name	Description
31:5	RSV0	Reserved
4:0	FAW	Four Activated Windows (FAW) Period DDR2 devices impose a restriction in that no more than 4 ACTIVE commands may be issued in a given FAW period. To obtain this value, one should divide the Four Bank Activate period (TFAW) of the DDR by the clock cycle time. These bits are ignored in 4 bank devices.

10000360 DDR_DQ_DLY DDR1/DDR2 DQ delay control register

0000888
8

Bit	31	30	29	28	27	26	25	24	23	22	21	20	19	18	17	16
Name	DQ_GROUP1_DELAY_SEL								DQ_GROUP0_DELAY_SEL							
Type	RW								RW							
Reset	0	0	0	0	0	0	0	0	0	0	0	0	0	0	0	0
Bit	15	14	13	12	11	10	9	8	7	6	5	4	3	2	1	0
Name	DQ_GROUP1_DELAY_COARSE_TUNING				DQ_GROUP1_DELAY_FINE_TUNING				DQ_GROUP0_DELAY_COARSE_TUNING				DQ_GROUP0_DELAY_FINE_TUNING			
Type	RW				RW				RW				RW			
Reset	1	0	0	0	1	0	0	0	1	0	0	0	1	0	0	0

Bit(s)	Name	Description
31:24	DQ_GROUP1_DELAY_SEL	Force Data Group 1 (MD8 to MD15) Output Delay. Valid when DQ_DLY_SEL_EN is 1. bit7~4: for coarse-grain delay setting bit3~0: for fine-grain delay setting
23:16	DQ_GROUP0_DELAY_SEL	Force Data Group 0 (MD0 to MD7) Output Delay. Valid when DQ_DLY_SEL_EN is 1. bit7~4: for coarse-grain delay setting bit3~0: for fine-grain delay setting
15:12	DQ_GROUP1_DELAY_COARSE_TUNING	Data Group 1 (MD8 to MD15) Output Delay Coarse-Grain Tuning 0x0 to 0x7: Decrease delay by 250 ps per step. 0x8: Keep DLL delay. 0x9 to 0xF: Increase delay by 250 ps per step.
11:8	DQ_GROUP1_DELAY_FINE_TUNING	Data Group 1 (MD8 to MD15) Output Delay Fine-Grain Tuning 0x0 to 0x7: Decrease delay by 30 ps per step. 0x8: Keep DLL delay. 0x9 to 0xF: Increase delay by 30 ps per step.
7:4	DQ_GROUP0_DELAY_COARSE_TUNING	Data Group 0 (MD0 to MD7) Output Delay Coarse-Grain Tuning 0x0 to 0x7: Decrease delay by 250 ps per step. 0x8: Keep DLL delay. 0x9 to 0xF: Increase delay by 250 ps per step.
3:0	DQ_GROUP0_DELAY_FINE_TUNING	Data Group 0 (MD0 to MD7) Output Delay Fine-Grain Tuning 0x0 to 0x7: Decrease delay by 30 ps per step. 0x8: Keep DLL delay. 0x9 to 0xF: Increase delay by 30 ps per step.

10000364 DDR_DQS_DLY DDR1/DDR2 DQS delay control register

0000888
8

Bit	31	30	29	28	27	26	25	24	23	22	21	20	19	18	17	16
Name	DQS1_DELAY_SEL								DQS0_DELAY_SEL							
Type	RW								RW							
Reset	0	0	0	0	0	0	0	0	0	0	0	0	0	0	0	0
Bit	15	14	13	12	11	10	9	8	7	6	5	4	3	2	1	0
Name	DQS1_DELAY_COARSE_TUNING				DQS1_DELAY_FINE_TUNING				DQS0_DELAY_COARSE_TUNING				DQS0_DELAY_FINE_TUNING			
Type	RW				RW				RW				RW			
Reset	1	0	0	0	1	0	0	0	1	0	0	0	1	0	0	0

Bit(s)	Name	Description
31:24	DQS1_DELAY_SEL	Force Data Strobe 1 (MDQS1) Input Delay. Valid when DQS_DLY_SEL_EN is 1 bit7~4: for coarse-grain delay setting bit3~0: for fine-grain delay setting
23:16	DQS0_DELAY_SEL	Force Data Strobe 0 (MDQS0) Input Delay. Valid when DQS_DLY_SEL_EN is 1

Bit(s)	Name	Description
15:12	DQS1_DELAY_COARSE_TUNING	Data Strobe 1 Input Delay Coarse-Grain Tuning bit7~4: for coarse-grain delay setting bit3~0: for fine-grain delay setting 0x0 to 0x7: Decrease delay by 250 ps per step. 0x8: Keep DLL delay. 0x9 to 0xF: Increase delay by 250 ps per step.
11:8	DQS1_DELAY_FINE_TUNING	Data Strobe 1 Input Delay Fine-Grain Tuning 0x0 to 0x7: Decrease delay by 30 ps per step. 0x8: Keep DLL delay. 0x9 to 0xF: Increase delay by 30 ps per step.
7:4	DQS0_DELAY_COARSE_TUNING	Data Strobe 0 Input Delay Coarse-Grain Tuning 0x0 to 0x7: Decrease delay by 250 ps per step. 0x8: Keep DLL delay. 0x9 to 0xF: Increase delay by 250 ps per step.
3:0	DQS0_DELAY_FINE_TUNING	Data Strobe 0 Input Delay Fine-Grain Tuning 0x0 to 0x7: Decrease delay by 30 ps per step. 0x8: Keep DLL delay. 0x9 to 0xF: Increase delay by 30 ps per step.

10000368 DDR_DLL_SLV DDR1/DDR2 DLL slave control register 00000000

Bit	31	30	29	28	27	26	25	24	23	22	21	20	19	18	17	16	
Name	RSV0[22:7]																
Type	RO																
Reset	0	0	0	0	0	0	0	0	0	0	0	0	0	0	0	0	
Bit	15	14	13	12	11	10	9	8	7	6	5	4	3	2	1	0	
Name	RSV0[6:0]							DLL_SLV_UPDATE_MODE	RSV1				DQS_DLY_SEL_EN	RSV2			DQ_DLY_SEL_EN
Type	RO							RW	RO				RW	RO			RW
Reset	0	0	0	0	0	0	0	0	0	0	0	0	0	0	0	0	

Bit(s)	Name	Description
31:9	RSV0	Reserved
8	DLL_SLV_UPDATE_MODE	Set DLL slave update mode. 0: Update delay code only when bank is activated. 1: Continuous update
7:5	RSV1	Reserved
4	DQS_DLY_SEL_EN	0: DQS Input Delay decided by DLL. 1: Force DQS Input Delay by DQS0_DELAY_SEL / DQS1_DELAY_SEL.
3:1	RSV2	Reserved
0	DQ_DLY_SEL_EN	0: DQ Output Delay decided by DLL. 1: Force DQ Output Delay by DQ_GROUP0_DELAY_SEL / DQ_GROUP1_DELAY_SEL.

1000036C DDR_DLL_MS DDR1/DDR2 DLL master control register 00000000

Bit	31	30	29	28	27	26	25	24	23	22	21	20	19	18	17	16	
Name	DLL_MAS_RE	RSV0					DLL_MAS_BY	DLL_MAS_BY	RSV1[11:4]								

	LO CK _EN						PA SS _FD	PA SS _CD								
Type	RW	RO					RW	RW	RO							
Reset	0	0	0	0	0	0	0	0	0	0	0	0	0	0	0	0
Bit	15	14	13	12	11	10	9	8	7	6	5	4	3	2	1	0
Name	RSV1[3:0]					DLL_MAS_FIXED_FD			RSV2		DLL_MAS_FIXED_CD					
Type	RO					RW			RO		RW					
Reset	0	0	0	0	0	0	0	0	0	0	0	0	0	0	0	0

Bit(s)	Name	Description
31	DLL_MAS_RELOCK_EN	Delayed Locked Loop (DLL) Master Relock Enable 0: Disable relocking scheme. 1: Enable relocking scheme. DLL supports restarting locking from initial value if DLL is not locked after waiting 512 cycles.
30:26	RSV0	Reserved
25	DLL_MAS_BYPASS_FD	DLL Bypass Fine Grain Delay 0: Fine-grain delay code is determined by DLL. 1: Fine-grain delay code is fixed by DLL_MAS_FIXED_FD.
24	DLL_MAS_BYPASS_CD	DLL Bypass Coarse Grain Delay 0: Coarse-grain delay code is determined by DLL. 1: Coarse-grain delay code is fixed by DLL_MAS_FIXED_CD.
23:12	RSV1	Reserved
11:8	DLL_MAS_FIXED_FD	DLL Fixed Fine Grain Delay Specifies the fine-grain delay. The effective range is 0 to 15. Each step is about 30 ps.
7:6	RSV2	Reserved
5:0	DLL_MAS_FIXED_CD	DLL Fixed Coarse Grain Delay Specifies the coarse-grain delay. The delay = ((x-2)/4-1)*250 ps, the effective range of x is 10 to 52.

10000380 MC_ARB_CFG MC 2 to 1 arbiter setting 07FAC6 88

Bit	31	30	29	28	27	26	25	24	23	22	21	20	19	18	17	16
Name	RSV0					pre em pt _en	trtc _en	clas s_e n	cls_priority[23:16]							
Type	RO					RW	RW	RW	RW							
Reset	0	0	0	0	0	1	1	1	1	1	1	1	1	0	1	0
Bit	15	14	13	12	11	10	9	8	7	6	5	4	3	2	1	0
Name	cls_priority[15:0]															
Type	RW															
Reset	1	1	0	0	0	1	1	0	1	0	0	0	1	0	0	0

Bit(s)	Name	Description
31:27	RSV0	Reserved
26	preempt_en	Preemption Enable Request preemption, higher priority requestor may change current request transaction 0: Disable Preemption 1: Enable Preemption
25	trtc_en	Two Rate Three Color Bandwidth (TRTC) Meter Enable 0: Disable TRTC 1: Enable TRTC
24	class_en	QoS Classifier Enable 0: Disable CLASS 1: Enable CLASS TRTC (0) CLASS (0) Round Robin

Bit(s)	Name	Description
23:0	cls_priority	<p>TRTC (0) CLASS (1) Fixed Priority TRTC (1) CLASS (0) BW RR TRTC (1) CLASS (1) QoS Arb</p> <p>Class Priority This field is used for class priority for second arbitration. {BEy(3'd7), LCg(3'd6), BSy(3'd5), LSy(3'd4), BEg (3'd3), BSg (3'd2), LSg(3'd1), LCgd(3'd0)}</p>

10000384 **MC_AG_BW** **MC Channel BW/QoS_Type/DueDate Setting** **0110FF4**
 0

Bit	31	30	29	28	27	26	25	24	23	22	21	20	19	18	17	16
Name	ag_wr	RSV0			ag_sel	RSV1		ag_qos_type	ag_duedate							
Type	WO	RO			RW	RO		RW	RW							
Reset	0	0	0	0	0	0	0	1	0	0	0	1	0	0	0	0
Bit	15	14	13	12	11	10	9	8	7	6	5	4	3	2	1	0
Name	ag_pir								ag_cir							
Type	RW								RW							
Reset	1	1	1	1	1	1	1	1	0	1	0	0	0	0	0	0

Bit(s)	Name	Description
31	ag_wr	<p>Agent Write 0: Read 1: Write</p>
30:29	RSV0	Reserved
28	ag_sel	<p>DMA Agent Select Selects a DMA agent to configure. 0: CPU (Rbus0) 1: DMA (Rbus1)</p>
27:26	RSV1	Reserved
25:24	ag_qos_type	<p>Agent QoS Type 0: Latency critical 1: Latency sensitive (CPU) 2: Bandwidth sensitive (DMA) 3: Best Effort</p>
23:16	ag_duedate	<p>Due date for latency critical agent (unit: system bus clock cycle - system bus is 300 MHz or 225 MHz depending on bootstrap value.)</p>
15:8	ag_pir	<p>Peak Information Rate for the Agent The PIR is greater than or equal to the CIR. Bandwidth which exceeds PIR is marked red. 0x00: 0 MB/s 0x01: 8 MB/s ... 0x40: 512 MB/s ... 0xFF: 2040 MB/s (Max)</p>
7:0	ag_cir	<p>Committed Information Rate for the Agent Bandwidth which falls below the CIR is marked green. BW which exceeds the CIR but is below the EIR is marked yellow. 0x00: 0 MB/s 0x01: 8 MB/s ... 0x40: 512 MB/s (default) ... 0xFF: 2040 MB/s (Max)</p>

10000390 **RB_DBG** RB Debug 0000000
0

Bit	31	30	29	28	27	26	25	24	23	22	21	20	19	18	17	16
Name	RSV0[30:15]															
Type	RO															
Reset	0	0	0	0	0	0	0	0	0	0	0	0	0	0	0	0
Bit	15	14	13	12	11	10	9	8	7	6	5	4	3	2	1	0
Name	RSV0[14:0]															rb_sel
Type	RO															RW
Reset	0	0	0	0	0	0	0	0	0	0	0	0	0	0	0	0

Bit(s)	Name	Description
31:1	RSV0	Reserved
0	rb_sel	RB channel select for debug message dump

10000394 **RB_STATE** RB Debug State 0000000
0

Bit	31	30	29	28	27	26	25	24	23	22	21	20	19	18	17	16
Name	RSV0[20:5]															
Type	RO															
Reset	0	0	0	0	0	0	0	0	0	0	0	0	0	0	0	0
Bit	15	14	13	12	11	10	9	8	7	6	5	4	3	2	1	0
Name	RSV0[4:0]				rb_rw	rb_state	rb_length									
Type	RO				RO	RO	RO									
Reset	0	0	0	0	0	0	0	0	0	0	0	0	0	0	0	0

Bit(s)	Name	Description
31:11	RSV0	Reserved
10	rb_rw	RB channel RW
9:8	rb_state	RB channel State 2'b00: IDLE 2'b01: REQ 2'b10: ACK 2'b11: DATA
7:0	rb_length	RB channel burst length (Byte)

10000398 **RB_BW** RB Bandwidth 0000000
0

Bit	31	30	29	28	27	26	25	24	23	22	21	20	19	18	17	16
Name	bw_rst	RSV0	avg_bw										peak_bw[9:6]			
Type	WO	RO	RO										RO			
Reset	0	0	0	0	0	0	0	0	0	0	0	0	0	0	0	0
Bit	15	14	13	12	11	10	9	8	7	6	5	4	3	2	1	0
Name	peak_bw[5:0]					rb_bw										
Type	RO					RO										
Reset	0	0	0	0	0	0	0	0	0	0	0	0	0	0	0	0

Bit(s)	Name	Description
31	bw_rst	Write 1 will reset BW values.
30	RSV0	Reserved
29:20	avg_bw	Average BW (MB/S)
19:10	peak_bw	Peak BW (MB/S)
9:0	rb_bw	RB channel BW (MB/S)

1000039C RB_LAT RB Latency 0000000
0

Bit	31	30	29	28	27	26	25	24	23	22	21	20	19	18	17	16
Name	lat_rst	RSV0	avg_lat										peak_lat[9:6]			
Type	WO	RO	RO										RO			
Reset	0	0	0	0	0	0	0	0	0	0	0	0	0	0	0	0
Bit	15	14	13	12	11	10	9	8	7	6	5	4	3	2	1	0
Name	peak_lat[5:0]						rd_lat									
Type	RO						RO									
Reset	0	0	0	0	0	0	0	0	0	0	0	0	0	0	0	0

Bit(s)	Name	Description
31	lat_rst	Write 1 will reset latency values
30	RSV0	Reserved
29:20	avg_lat	Average read latency (T)
19:10	peak_lat	Peak read latency (T)
9:0	rd_lat	RB channel read latency (T)

5.6 R-Bus Controller

5.6.1 Features

- 8 channel QoS Arbiter
- Configurable Bandwidth and Duedate for each agent
- QoS classifier can be programmed for RR, BW RR, Fixed Priority and QoS Arb

5.6.2 Block Diagram

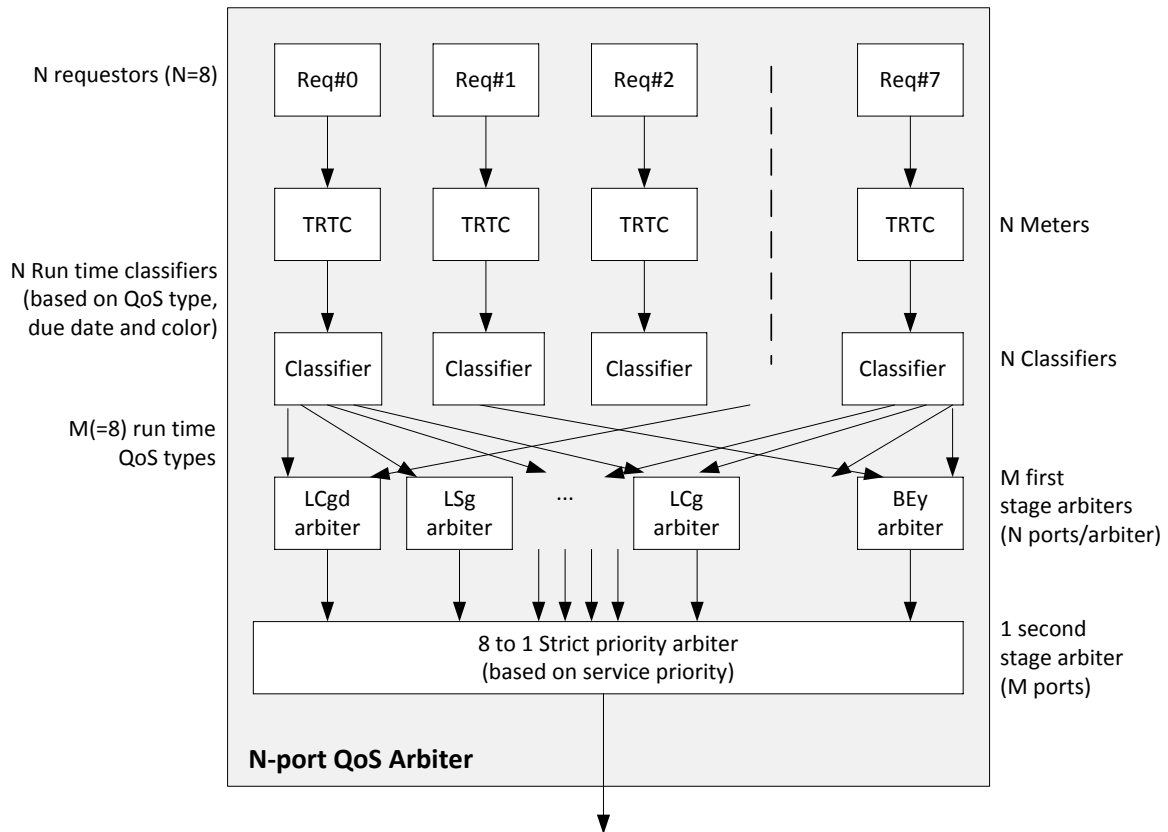

Figure 5-3 QoS Arbitration Block Diagram

5.6.3 Register

Rbus_Matrix_CTRL Changes LOG

Revision	Date	Author	Change Log
0.1	2012/10/2	Lancelot	Initialization
0.2	2013/1/3	Lancelot	Add sleep count
0.2	2013/8/19	YS Xiao	Modify to as MT7621's dma_ch_csr

Module name: Rbus_Matrix_CTRL Base address: (+10000400h)

Address	Name	Width	Register Function
10000400	<u>DMA_ARB_CFG</u>	32	DMA 8 to 1 arbiter setting
10000404	<u>DMA_AG_BW</u>	32	DMA Channel BW/QoS_Type/DueDate Setting

	CFG		
1000040C	DMA_ROUTE	32	DMA Routing
10000410	DMA_MON_AG_SEL	32	DMA Monitor Agent Select
10000414	DMA_STATE	32	DMA State
10000418	DMA_BW	32	DMA Bandwidth
1000041C	DMA_LAT	32	DMA Latency
10000420	OCP_CFG0	32	OCP to Rbus configuration
10000424	OCP_CFG1	32	Read bypass write mask
10000430	R2P_MONITOR	32	Rbus to APbus monitor
10000434	R2P_ERR_ADDR	32	Rbus to APbus error address
10000440	DYN_CFG0	32	Dynamic cpu/ocp frequency control
10000444	DYN_CFG1	32	CPU sleep step frequency control
10000448	DYN_CFG2	32	Dyn CFG Probe
1000044C	DYN_CFG3	32	SI_Sleep Serial Counter Setting
10000450	DYN_CFG4	32	SI_Sleep Issue Count Counter
10000454	DYN_CFG5	32	Sleep Time Counter for SI_Sleep
10000458	DYN_CFG6	32	Operation Time Counter for non SI_Sleep

10000400 **DMA_ARB_CFG** **DMA 8 to 1 arbiter setting** **04FAC6**
88

Bit	31	30	29	28	27	26	25	24	23	22	21	20	19	18	17	16
Name	RSV0					preempt_en	trtc_en	class_en	cls_priority[23:16]							
Type	RO					RW	RW	RW	RW							
Reset	0	0	0	0	0	1	0	0	1	1	1	1	1	0	1	0
Bit	15	14	13	12	11	10	9	8	7	6	5	4	3	2	1	0
Name	cls_priority[15:0]															
Type	RW															
Reset	1	1	0	0	0	1	1	0	1	0	0	0	1	0	0	0

Bit(s)	Name	Description
31:27	RSV0	Reserved
26	preempt_en	Preemption Enable Request preemption, higher priority requestor may change current request transaction 0: Disable Preemption 1: Enable Preemption
25	trtc_en	Two Rate Three Color Bandwidth (TRTC) Meter Enable 0: Disable TRTC 1: Enable TRTC
24	class_en	QoS Classifier Enable 0: Disable CLASS 1: Enable CLASS TRTC (0) CLASS (0) Round Robin TRTC (0) CLASS (1) Fixed Priority TRTC (1) CLASS (0) BW RR TRTC (1) CLASS (1) QoS Arb
23:0	cls_priority	Class Priority This field is used for class priority for second arbitration. {BEy(3'd7), LCg(3'd6), BSy(3'd5), LSy(3'd4), BEg (3'd3), BSG (3'd2), LSG(3'd1), LCGd(3'd0)}

10000404 DMA_AG_BW_CFG DMA Channel BW/QoS_Type/DueDate Setting 0220802
0

Bit	31	30	29	28	27	26	25	24	23	22	21	20	19	18	17	16
Name	ag_wr	ag_sel			RSV0		ag_qos_type		ag_duedate							
Type	W1C	RW			RO		RW		RW							
Reset	0	0	0	0	0	0	1	0	0	0	1	0	0	0	0	0
Bit	15	14	13	12	11	10	9	8	7	6	5	4	3	2	1	0
Name	ag_pir							ag_cir								
Type	RW							RW								
Reset	1	0	0	0	0	0	0	0	0	0	1	0	0	0	0	0

Bit(s)	Name	Description
31	ag_wr	Agent Write 0: Read 1: Write
30:28	ag_sel	DMA Agent Select Selects a DMA agent to configure. 0: SDXC 1: GDMA 2: SPI Slave/3-Wire SPI Slave/PUTIF 3: Switch 4: WLAN 5: PCIe 6: AES 7: USB20
27:26	RSV0	Reserved
25:24	ag_qos_type	Agent QoS Type 0: Latency critical 1: Latency sensitive 2: Bandwidth sensitive (default) 3: Best Effort
23:16	ag_duedate	Due date for latency critical agent (unit: system bus clock cycle - system bus is 300 MHz or 225 MHz depending on bootstrap value.)
15:8	ag_pir	Peak Information Rate for the Agent The PIR is greater than or equal to the CIR. Bandwidth which exceeds PIR is marked red. 0x00: 0 MB/s 0x01: 4 MB/s ... 0x80: 512 MB/s (default) ... 0xFF: 1020 MB/s (Max)
7:0	ag_cir	Committed Information Rate for the Agent Bandwidth which falls below the CIR is marked green. BW which exceeds the CIR but is below the EIR is marked yellow. 0x00: 0 MB/s 0x01: 4 MB/s ... 0x20: 128 MB/s (default) ... 0xFF: 1020 MB/s (Max)

1000040C DMA_ROUTE DMA Routing 0000000
0

Bit	31	30	29	28	27	26	25	24	23	22	21	20	19	18	17	16
Name	RSV0[30:15]															
Type	RO															
Reset	0	0	0	0	0	0	0	0	0	0	0	0	0	0	0	0

Bit(s)	Name	Description
		2'b11: DATA
7:0	dma_length	DMA channel burst length (Byte) state

10000418 **DMA_BW** DMA Bandwidth 0000000
0

Bit	31	30	29	28	27	26	25	24	23	22	21	20	19	18	17	16
Name	bw_rst	RSV0	avg_bw										peak_bw[9:6]			
Type	WO	RO	RO										RO			
Reset	0	0	0	0	0	0	0	0	0	0	0	0	0	0	0	0
Bit	15	14	13	12	11	10	9	8	7	6	5	4	3	2	1	0
Name	peak_bw[5:0]					dma_bw										
Type	RO					RO										
Reset	0	0	0	0	0	0	0	0	0	0	0	0	0	0	0	0

Bit(s)	Name	Description
31	bw_rst	Write 1 will reset BW values.
30	RSV0	Reserved
29:20	avg_bw	Average BW (MB/S)
19:10	peak_bw	Peak BW (MB/S)
9:0	dma_bw	DMA channel BW (MB/S)

1000041C **DMA_LAT** DMA Latency 0000000
0

Bit	31	30	29	28	27	26	25	24	23	22	21	20	19	18	17	16
Name	lat_rst	RSV0	avg_lat										peak_lat[9:6]			
Type	WO	RO	RO										RO			
Reset	0	0	0	0	0	0	0	0	0	0	0	0	0	0	0	0
Bit	15	14	13	12	11	10	9	8	7	6	5	4	3	2	1	0
Name	peak_lat[5:0]					rd_lat										
Type	RO					RO										
Reset	0	0	0	0	0	0	0	0	0	0	0	0	0	0	0	0

Bit(s)	Name	Description
31	lat_rst	Write 1 will reset latency values
30	RSV0	Reserved
29:20	avg_lat	Average read latency (T)
19:10	peak_lat	Peak read latency (T)
9:0	rd_lat	DMA channel read latency (T)

10000420 **OCP_CFG0** OCP to Rbus configuration 0000000
1

Bit	31	30	29	28	27	26	25	24	23	22	21	20	19	18	17	16
Name	RSV0[27:12]															
Type	RO															
Reset	0	0	0	0	0	0	0	0	0	0	0	0	0	0	0	0
Bit	15	14	13	12	11	10	9	8	7	6	5	4	3	2	1	0
Name	RSV0[11:0]												syn_c_method	ocp_sync_cm d	rbus_a syn c	rd_bypass_w r
Type	RO												RW	RW	RW	RW

Reset	0	0	0	0	0	0	0	0	0	0	0	0	0	0	0	0	1
--------------	---	---	---	---	---	---	---	---	---	---	---	---	---	---	---	---	---

Bit(s)	Name	Description
31:4	RSV0	Reserved
3	sync_method	OCP Synchronization Command Method 0: All empty (Wait until all FIFOs are empty) 1: CMD empty (Wait until the CMD FIFO is empty)
2	ocp_sync_cmd	OCP Synchronization Command Method Enable Remaps this RD CMD to address 0x0000_0000. Initiate DRAM control before enabling this option. 0: Disable 1: Enable
1	rbus_async	Async Mode for RBUS 0: Set HW to switch between sync or async mode dynamically. 1: Force RBUS to A.sync mode.
0	rd_bypass_wr	Read Bypass Write Enable Allows read commands to bypass write commands for OCP_IF when the address does not conflict. 0: Disable 1: Enable

10000424 OCP_CFG1 Read bypass write mask FFFFFFFF

Bit	31	30	29	28	27	26	25	24	23	22	21	20	19	18	17	16
Name	rd_bypass_wr_mask[31:16]															
Type	RW															
Reset	1	1	1	1	1	1	1	1	1	1	1	1	1	1	1	1
Bit	15	14	13	12	11	10	9	8	7	6	5	4	3	2	1	0
Name	rd_bypass_wr_mask[15:0]															
Type	RW															
Reset	1	1	1	1	1	1	1	1	1	1	1	1	1	1	1	1

Bit(s)	Name	Description
31:0	rd_bypass_wr_mask	Mask bit for read bypass write address

10000430 R2P_MONITO Rbus to APbus monitor 0000000

Bit	31	30	29	28	27	26	25	24	23	22	21	20	19	18	17	16
Name	RSV0															r2p_inc_clr
Type	RO															W1C
Reset	0	0	0	0	0	0	0	0	0	0	0	0	0	0	0	0
Bit	15	14	13	12	11	10	9	8	7	6	5	4	3	2	1	0
Name	r2p_err_cnt							r2p_inc_cnt								
Type	RO							RW								
Reset	0	0	0	0	0	0	0	0	0	0	0	0	0	0	0	0

Bit(s)	Name	Description
31:17	RSV0	Reserved
16	r2p_inc_clr	R2APB Interrupt Clear Write 1 to clear this interrupt.
15:10	r2p_err_cnt	R2APB error counter
9:0	r2p_inc_cnt	R2APB Interrupt Countdown Timer Sets a delay timer which begins counting down when an R2P error is

Bit(s)	Name	Description
		detected. When the timer reaches zero the R2P interrupt is then triggered.
		10'b0000000000: Disable R2P monitoring
		10'b0000000001: 20 us
		10'b0000000010: 40 us
		...
		10'b1000000000: 40 ms

10000434 R2P_ERR_AD Rbus to APbus error address 0000000
DR 0

Bit	31	30	29	28	27	26	25	24	23	22	21	20	19	18	17	16
Name	r2p_err_addr[31:16]															
Type	RO															
Reset	0	0	0	0	0	0	0	0	0	0	0	0	0	0	0	0
Bit	15	14	13	12	11	10	9	8	7	6	5	4	3	2	1	0
Name	r2p_err_addr[15:0]															
Type	RO															
Reset	0	0	0	0	0	0	0	0	0	0	0	0	0	0	0	0

Bit(s)	Name	Description
31:0	r2p_err_addr	R2APB address record for previous error found

10000440 DYN_CFG0 Dynamic cpu/ocp frequency control 00030A0
1

Bit	31	30	29	28	27	26	25	24	23	22	21	20	19	18	17	16
Name	RSV0													cpu_ocp_ratio		
Type	RO													RW		
Reset	0	0	0	0	0	0	0	0	0	0	0	0	0	0	1	1
Bit	15	14	13	12	11	10	9	8	7	6	5	4	3	2	1	0
Name	RSV1				cpu_fdiv				RSV2				cpu_ffrac			
Type	RO				RW				RO				RW			
Reset	0	0	0	0	1	0	1	0	0	0	0	0	0	0	0	1

Bit(s)	Name	Description
31:19	RSV0	Reserved
18:16	cpu_ocp_ratio	CPU OCP Ratio The ratio between the system bus frequency and the CPU frequency. 3'b011: SYS/CPU = 1/3 3'b100: SYS/CPU = 1/4 (Not used in MT7628)
15:12	RSV1	Reserved
11:8	cpu_fdiv	CPU Frequency Divider The frequency divider is used to generate the CPU frequency. Valid values range from 1 to 15. NOTE1: CPU_FDIV must be equaled to N*CPU_FFRAC(N is a integer number) when rbus_async equal to 1'b0. NOTE2: CPU_FDIV must be larger than or equal to CPU_FFRAC when rbus_async equal to 1'b1.
7:4	RSV2	Reserved
3:0	cpu_ffrac	CPU Frequency Fractional A parameter used in conjunction with the CPU frequency divider to determine the CPU frequency. Input a value in the following equation to determine the CPU frequency. CPU frequency = PLL_FREQ*(CPU_FFRAC/CPU_FDIV) NOTE: If the chip runs in USB OHCI mode, the OCP frequency cannot be lower than 30 MHz. It means that PLL_FREQ*(CPU_FFRAC/CPU_FDIV)/CPU_OCP_RATIO >= 30 MHz.

10000444 DYN_CFG1 CPU sleep step frequency control

00230A0
6

Bit	31	30	29	28	27	26	25	24	23	22	21	20	19	18	17	16	
Name	slp_en	step_en	RSV0		step_cnt								RSV1	step_ocp_ratio			
Type	RW	RW	RO		RW								RO	RO			
Reset	0	0	0	0	0	0	0	0	0	0	0	1	0	0	0	1	1
Bit	15	14	13	12	11	10	9	8	7	6	5	4	3	2	1	0	
Name	RSV2				step_fdiv				RSV3				step_ffrac				
Type	RO				RO				RO				RW				
Reset	0	0	0	0	1	0	1	0	0	0	0	0	0	0	1	1	0

Bit(s)	Name	Description
31	slp_en	Sleep Mode Enable Enables sleep mode when MIPS SI_Sleep is asserted. 0: Disable 1: Enable Sleep Mode CPU Frequency = PLL_FREQ*(1/CPU_FDIV)
30	step_en	Step Jump Enable Enables step jump after MIPS exits sleep mode. The CPU will jump to the normal frequency in increments defined by STEP_FFRAC.bit[4:0] of this register. 0: Disable 1: Enable
29:28	RSV0	Reserved
27:20	step_cnt	Step Counter Sets the period of each step jump. When the counter counts down to zero, the CPU clock automatically changes to the next step frequency. The count period unit is 1 us.
19	RSV1	Reserved
18:16	step_ocp_ratio	Step OCP Ratio (Fix to cpu_ocp_ratio) The ratio between the system bus frequency and the CPU frequency. 3'b011: SYS/CPU = 1/3 3'b100: SYS/CPU = 1/4 (Not used in MT7628)
15:12	RSV2	Reserved
11:8	step_fdiv	Step Frequency Divider (Fix to CPU_FDIV) The frequency divider is used to generate the CPU frequency after the CPU exits from sleep mode and returns to normal operation. Valid values range from 1 to 15.
7:4	RSV3	Reserved
3:0	step_ffrac	Step Frequency Fraction The fractional size of the increment in CPU frequency after the CPU exits from sleep mode and returns to normal operation. This step is only valid when SLP_STEP_EN is enabled. FRAC_VALUE = PREVIOUS_FRAC_VALUE + STEP_FFRAC CPU Frequency = (FRAC_VALUE/CPU_FDIV)*PLL_FREQ

10000448 DYN_CFG2 Dyn CFG Probe

00030A0
1

Bit	31	30	29	28	27	26	25	24	23	22	21	20	19	18	17	16	
Name	RSV0				dfc_fsm				RSV1				same_freq	RSV2	cpu_ocp_ratio		
Type	RO				RO				RO				RO	RO	RO		
Reset	0	0	0	0	0	0	0	0	0	0	0	0	0	0	0	1	1
Bit	15	14	13	12	11	10	9	8	7	6	5	4	3	2	1	0	

Name	RSV3				cpu_fdiv				RSV4				cpu_ffrac			
Type	RO				RO				RO				RO			
Reset	0	0	0	0	1	0	1	0	0	0	0	0	0	0	0	1

Bit(s)	Name	Description
31:27	RSV0	Dynamic frequency controller's main FSM current state
26:24	dfc_fsm	Dynamic frequency controller's main FSM current state
23:21	RSV1	Reserved
20	same_freq	Indicates that the SYS and DRAM clocks are on the same frequency.
19	RSV2	Reserved
18:16	cpu_ocratio	OCP ratio after changed frequency
15:12	RSV3	Reserved
11:8	cpu_fdiv	CPU fdiv after changed frequency
7:4	RSV4	Reserved
3:0	cpu_ffrac	CPU ffrac after changed frequency

1000044C **DYN_CFG3** **SI_Sleep Serial Counter Setting** **0000000**
0

Bit	31	30	29	28	27	26	25	24	23	22	21	20	19	18	17	16	
Name	si_slp_cnt_en	RSV0				si_slp_time_unit[27:16]											
Type	RW	RO				RW											
Reset	0	0	0	0	0	0	0	0	0	0	0	0	0	0	0	0	0
Bit	15	14	13	12	11	10	9	8	7	6	5	4	3	2	1	0	
Name	si_slp_time_unit[15:0]																
Type	RW																
Reset	0	0	0	0	0	0	0	0	0	0	0	0	0	0	0	0	

Bit(s)	Name	Description
31	si_slp_cnt_en	SI_Sleep Serial Counter Enable
30:28	RSV0	Reserved
27:0	si_slp_time_unit	SI_Sleep Time Counter unit 28'h0000000: count per 1us 28'h0000001: count per 2us 28'h0000002: count per 3us ... 28'hffffff: count per 268435456us

10000450 **DYN_CFG4** **SI_Sleep Issue Count Counter** **0000000**
0

Bit	31	30	29	28	27	26	25	24	23	22	21	20	19	18	17	16
Name	si_slp_cnt[31:16]															
Type	W1C															
Reset	0	0	0	0	0	0	0	0	0	0	0	0	0	0	0	0
Bit	15	14	13	12	11	10	9	8	7	6	5	4	3	2	1	0
Name	si_slp_cnt[15:0]															
Type	W1C															
Reset	0	0	0	0	0	0	0	0	0	0	0	0	0	0	0	0

Bit(s)	Name	Description
31:0	si_slp_cnt	SI_Sleep Issue Count Counter Write to this register will clear the counter value.

10000454 DYN_CFG5 Sleep Time Counter for SI_Sleep 0000000
0

Bit	31	30	29	28	27	26	25	24	23	22	21	20	19	18	17	16
Name	si_slp_time_unit_cnt[31:16]															
Type	W1C															
Reset	0	0	0	0	0	0	0	0	0	0	0	0	0	0	0	0
Bit	15	14	13	12	11	10	9	8	7	6	5	4	3	2	1	0
Name	si_slp_time_unit_cnt[15:0]															
Type	W1C															
Reset	0	0	0	0	0	0	0	0	0	0	0	0	0	0	0	0

Bit(s)	Name	Description
31:0	si_slp_time_unit_cnt	Sleep Time Counter for SI_Sleep Finally, CPU in SI_Sleep time is "si_slp_time_unit_cnt*si_slp_time_unit(us)". Write to this register will clear the counter value.

10000458 DYN_CFG6 Operation Time Counter for non SI_Sleep 0000000
0

Bit	31	30	29	28	27	26	25	24	23	22	21	20	19	18	17	16
Name	si_opt_time_unit_cnt[31:16]															
Type	W1C															
Reset	0	0	0	0	0	0	0	0	0	0	0	0	0	0	0	0
Bit	15	14	13	12	11	10	9	8	7	6	5	4	3	2	1	0
Name	si_opt_time_unit_cnt[15:0]															
Type	W1C															
Reset	0	0	0	0	0	0	0	0	0	0	0	0	0	0	0	0

Bit(s)	Name	Description
31:0	si_opt_time_unit_cnt	Operation Time Counter for non SI_Sleep Finally, CPU in non SI_Sleep time is "si_opt_time_unit_cnt*si_slp_time_unit(us)". Write to this register will clear the counter value.

5.7 MIPS CNT

5.7.1 Registers

MIPS_CNT Changes LOG

Revision	Date	Author	Change Log
0.1	2013/1/14	YuShu Xiao	Initialization

Module name: MIPS_CNT Base address: (+10000500h)

Address	Name	Width	Register Function
10000500	<u>STCK_CNT_CFG</u>	32	MIPS Configuration
10000504	<u>CMP_CNT</u>	32	MIPS Compare Sets the cutoff point for the free run counter (MIPS counter). If the free run counter equals the compare counter, then the timer circuit generates an interrupt. The interrupt remains active until the compare counter is written again.
10000508	<u>CNT</u>	32	MIPS Counter The MIPS counter (free run counter) increases by 1 every 20 us (50 KHz). The counter continues to count until it reaches the value loaded into CMP_CNT.

10000500 STCK_CNT_CFG MIPS Configuration 00000000

Bit	31	30	29	28	27	26	25	24	23	22	21	20	19	18	17	16
Name	RESV[29:14]															
Type	RO															
Reset	0	0	0	0	0	0	0	0	0	0	0	0	0	0	0	0
Bit	15	14	13	12	11	10	9	8	7	6	5	4	3	2	1	0
Name	RESV[13:0]														EXT_STK_EN	CNT_EN
Type	RO														RW	RW
Reset	0	0	0	0	0	0	0	0	0	0	0	0	0	0	0	0

Bit(s)	Name	Description
31:2	RESV	
1	EXT_STK_EN	External System Tick Enable - Selects the system tick source. 0: Use the MIPS internal timer interrupts. 1: Use the external timer interrupt from an external MIPS counter.
0	CNT_EN	Counter Enable - Enable the free run counter (MIPS counter). 0: Disable 1: Enable

10000504 CMP_CNT MIPS Compare 00000000

Bit	31	30	29	28	27	26	25	24	23	22	21	20	19	18	17	16
Name	RESV															
Type	RO															
Reset	0	0	0	0	0	0	0	0	0	0	0	0	0	0	0	0
Bit	15	14	13	12	11	10	9	8	7	6	5	4	3	2	1	0
Name	CMP_CNT															
Type	RW															

5.8 General Purpose IO

5.8.1 Features

- Parameterized numbers of independent inputs, outputs, and inouts
- Independent polarity controls for each pin
- Independently masked edge detect interrupt on any input transition

5.8.2 Block Diagram

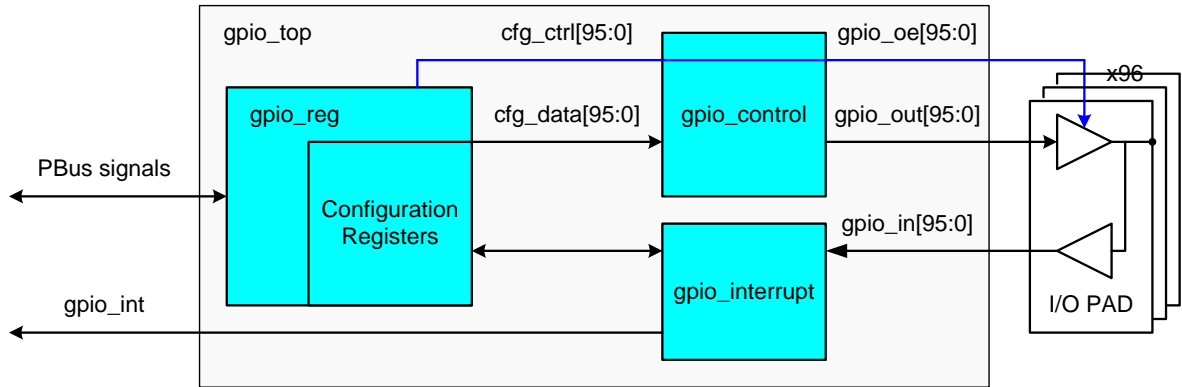

Figure 5-4 Programmable I/O Block Diagram

5.8.3 GPIO pin mapping

PAD Name	Function 0	Function 1	Function 2	Function 3	strap	pmux_group	GPIO
PAD_I2S_SDI	i2ssdi (I)	gpio (I/O)	pcmdrx (I)	antsel[5] (O)		i2s_gpio_psel[2:0]	0
PAD_I2S_SDO	i2ssdo (O)	gpio (I/O)	pcmdtx (O)	antsel[4] (O)	0	i2s_gpio_psel[2:0]	1
PAD_I2S_WS	i2sws(I/O)	gpio (I/O)	pcmclk (I/O)	antsel[3] (O)		i2s_gpio_psel[2:0]	2
PAD_I2S_CLK	i2sclk (I/O)	gpio (I/O)	pcmfs (I/O)	antsel[2] (O)		i2s_gpio_psel[2:0]	3
PAD_I2C_SCLK	i2c_sclk (I/O)	gpio (I/O)	sutif_txd (O)	ext_bgclk (I)		i2c_gpio_psel[2:0]	4
PAD_I2C_SD	i2c_sd (I/O)	gpio (I/O)	sutif_rxd (I)			i2c_gpio_psel[2:0]	5
PAD_SPI_CS1	spi_cs1 (O)	gpio (I/O)	co_clko (O)		1	spi_cs1_psel[2:0]	6
PAD_SPI_CLK	spi_clk (O)	gpio (I/O)			2	spi_gpio_psel[1:0]	7
PAD_SPI_MOSI	spi_mosi (I/O)	gpio (I/O)			3	spi_gpio_psel[1:0]	8
PAD_SPI_MISO	spi_miso (I/O)	gpio (I/O)				spi_gpio_psel[1:0]	9
PAD_SPI_CS0	spi_cs0 (O)	gpio (I/O)				spi_gpio_psel[1:0]	10
PAD_GPIO0	gpio (I/O)	gpio (I/O)	co_clko (O)	perst_n (O)	4	gpio_psel[2:0]	11
PAD_TXD0	txd0 (O)	gpio (I/O)			5	uart0_gpio_psel[2:0]	12
PAD_RXD0	rxd0 (I)	gpio (I/O)				uart0_gpio_psel[2:0]	13
PAD_MDI_TP_P1	spis_cs (I)	gpio (I/O)	w_utif[0] (I/O)	pwm_ch0 (O)		spis_gpio_psel[2:0]	14
PAD_MDI_TN_P1	spis_clk (I)	gpio (I/O)	w_utif[1] (I/O)	pwm_ch1 (O)		spis_gpio_psel[2:0]	15
PAD_MDI_RP_P1	spis_miso (O)	gpio (I/O)	w_utif[2] (I/O)	txd2 (O)		spis_gpio_psel[2:0]	16
PAD_MDI_RN_P1	spis_mosi (I)	gpio (I/O)	w_utif[3] (I/O)	rx2 (I)		spis_gpio_psel[2:0]	17
PAD_MDI_RP_P2	pwm_ch0 (O)	gpio (I/O)	w_utif[4] (I/O)	sd_d7 (I/O)		pwm0_gpio_psel[2:0]	18
PAD_MDI_RN_P2	pwm_ch1 (O)	gpio (I/O)	w_utif[5] (I/O)	sd_d6 (I/O)		pwm1_gpio_psel[2:0]	19
PAD_MDI_TP_P2	txd2 (O)	gpio (I/O)	pwm_ch2 (O)	sd_d5 (I/O)		uart2_gpio_psel[2:0]	20
PAD_MDI_TN_P2	rx2 (I)	gpio (I/O)	pwm_ch3 (O)	sd_d4 (I/O)		uart2_gpio_psel[2:0]	21
PAD_MDI_TP_P3	sd_wp (I)	gpio (I/O)	w_utif[10] (I/O)	w_dbgin (I)		sd_gpio_psel[2:0]	22
PAD_MDI_RN_P3	sd_cd (I)	gpio (I/O)	w_utif[11] (I/O)	w_dbgack (O)		sd_gpio_psel[2:0]	23
PAD_MDI_TP_P3	sd_d1 (I/O)	gpio (I/O)	w_utif[12] (I/O)	w_jtclk (I)		sd_gpio_psel[2:0]	24
PAD_MDI_RN_P3	sd_d0 (I/O)	gpio (I/O)	w_utif[13] (I/O)	w_jtdi (I)		sd_gpio_psel[2:0]	25
PAD_MDI_RP_P4	sd_clk (I/O)	gpio (I/O)	w_utif[14] (I/O)	w_jtdo (O)		sd_gpio_psel[2:0]	26
PAD_MDI_RN_P4	sd_cmd (I/O)	gpio (I/O)	w_utif[15] (I/O)	dbg_uart_txd (O)		sd_gpio_psel[2:0]	27
PAD_MDI_TP_P4	sd_d3 (I/O)	gpio (I/O)	w_utif[16] (I/O)	w_jtms (I)		sd_gpio_psel[2:0]	28
PAD_MDI_TN_P4	sd_d2 (I/O)	gpio (I/O)	w_utif[17] (I/O)	w_jtrst_n (I)		sd_gpio_psel[2:0]	29
PAD_EPHY_LED4_K	ephy_led4_k (O)	gpio (I/O)	w_utif_k[6] (I/O)	jtrstn_k (I)		p4_led_kn_psel[2:0]	30
PAD_EPHY_LED3_K	ephy_led3_k (O)	gpio (I/O)	w_utif_k[7] (I/O)	jtclk_k (I)		p3_led_kn_psel[2:0]	31
PAD_EPHY_LED2_K	ephy_led2_k (O)	gpio (I/O)	w_utif_k[8] (I/O)	jtms_k (I)		p2_led_kn_psel[2:0]	32
PAD_EPHY_LED1_K	ephy_led1_k (O)	gpio (I/O)	w_utif_k[9] (I/O)	jtdi_k (I)		p1_led_kn_psel[2:0]	33
PAD_EPHY_LED0_K	ephy_led0_k (O)	gpio (I/O)		jtdo_k (I/O)		p0_led_kn_psel[2:0]	34
PAD_WLED_K	wled_k (I/O)	gpio (I/O)				wled_kn_psel[2:0]	35
PAD_PERST_N	perst_n (O)	gpio (I/O)			6	prest_gpio_psel[1:0]	36
PAD_CO_CLKO	co_clko (O)	gpio (I/O)			7	rclk_gpio_psel[1:0]	37
PAD_WDT_RST_N	wdt (I/O)	gpio (I/O)				wdt_gpio_psel[1:0]	38
PAD_EPHY_LED4_N	ephy_led4_n (O)	gpio (I/O)	w_utif_n[6] (I/O)	jtrstn_n (I)		p4_led_gpio_psel[2:0]	39
PAD_EPHY_LED3_N	ephy_led3_n (O)	gpio (I/O)	w_utif_n[7] (I/O)	jtclk_n (I)		p3_led_gpio_psel[2:0]	40
PAD_EPHY_LED2_N	ephy_led2_n (O)	gpio (I/O)	w_utif_n[8] (I/O)	jtms_n (I)		p2_led_gpio_psel[2:0]	41
PAD_EPHY_LED1_N	ephy_led1_n (O)	gpio (I/O)	w_utif_n[9] (I/O)	jtdi_n (I)		p1_led_gpio_psel[2:0]	42
PAD_EPHY_LED0_N	ephy_led0_n (O)	gpio (I/O)		jtdo_n (I/O)		p0_led_gpio_psel[2:0]	43
PAD_WLED_N	wled_n (I/O)	gpio (I/O)				wled_gpio_psel[2:0]	44
PAD_TXD1	txd1 (O)	gpio (I/O)	pwm_ch0 (O)	antsel[1] (O)	8	uart1_gpio_psel[2:0]	45
PAD_RXD1	rx1 (I)	gpio (I/O)	pwm_ch1 (O)	antsel[0] (O)		uart1_gpio_psel[2:0]	46

5.8.4 Register
GPIO Changes LOG

Revision	Date	Author	Change Log
0.1	2012/6/21	YuShu Xiao	Initialization

Module name: GPIO Base address: (+1000600h)

Address	Name	Width	Register Function
1000600	<u>GPIO_CTRL_0</u>	32	GPIO0 to GPIO31 direction control register These direction control registers are used to select the data direction of the GPIO pin. The value driven onto the GPIO pins, are controlled by the GPIO_POL_x, and GPIO_DATA_x registers.
1000604	<u>GPIO_CTRL_1</u>	32	GPIO32 to GPIO63 direction control register These direction control registers are used to select the data direction of the GPIO pin. The value driven onto the GPIO pins, are controlled by the GPIO_POL_x, and GPIO_DATA_x registers.
1000608	<u>GPIO_CTRL_2</u>	32	GPIO64 to GPIO95 direction control register These direction control registers are used to select the data direction of the GPIO pin. The value driven onto the GPIO pins, are controlled by the GPIO_POL_x, and GPIO_DATA_x registers.
1000610	<u>GPIO_POL_0</u>	32	GPIO0 to GPIO31 polarity control register These polarity control registers are used to control the polarity of the data is driven on or read from the GPIO pin.
1000614	<u>GPIO_POL_1</u>	32	GPIO32 to GPIO63 polarity control register These polarity control registers are used to control the polarity of the data is driven on or read from the GPIO pin.
1000618	<u>GPIO_POL_2</u>	32	GPIO64 to GPIO95 polarity control register These polarity control registers are used to control the polarity of the data is driven on or read from the GPIO pin.
1000620	<u>GPIO_DATA_0</u>	32	GPIO0 to GPIO31 data register These data registers store current GPIO data value for GPIO input mode, or output driven value for GPIO output mode. Bit position stand for correspondent GPIO pin.
1000624	<u>GPIO_DATA_1</u>	32	GPIO32 to GPIO63 data register These data registers store current GPIO data value for GPIO input mode, or output driven value for GPIO output mode. Bit position stand for correspondent GPIO pin.
1000628	<u>GPIO_DATA_2</u>	32	GPIO64 to GPIO95 data register These data registers store current GPIO data value for GPIO input mode, or output driven value for GPIO output mode. Bit position stand for correspondent GPIO pin.
1000630	<u>GPIO_DSET_0</u>	32	GPIO0 to GPIO31 data set register These data set registers are used to set bits in the GPIO_DATA_x registers.
1000634	<u>GPIO_DSET_1</u>	32	GPIO32 to GPIO63 data set register These data set registers are used to set bits in the GPIO_DATA_x registers.
1000638	<u>GPIO_DSET_2</u>	32	GPIO64 to GPIO95 data set register These data set registers are used to set bits in the GPIO_DATA_x registers.
1000640	<u>GPIO_DCLR_0</u>	32	GPIO0 to GPIO31 data clear register These data set registers are used to clear bits in the GPIO_DATA_x registers.
1000644	<u>GPIO_DCLR_1</u>	32	GPIO32 to GPIO63 data clear register These data set registers are used to clear bits in the GPIO_DATA_x registers.
1000648	<u>GPIO_DCLR_2</u>	32	GPIO64 to GPIO95 data clear register These data set registers are used to clear bits in the GPIO_DATA_x registers.
1000650	<u>GINT_REDEGE_0</u>	32	GPIO0 to GPIO31 rising edge interrupt enable register These registers are used to enable the condition of rising edge triggered interrupt.
1000654	<u>GINT_REDEGE_</u>	32	GPIO32 to GPIO63 rising edge interrupt enable register

	<u>1</u>		These registers are used to enable the condition of rising edge triggered interrupt.
10000658	<u>GINT_REDEGE_2</u>	32	GPIO64 to GPIO95 rising edge interrupt enable register These registers are used to enable the condition of rising edge triggered interrupt.
10000660	<u>GINT_FEDGE_0</u>	32	GPIO0 to GPIO31 falling edge interrupt enable register These registers are used to enable the condition of falling edge triggered interrupt.
10000664	<u>GINT_FEDGE_1</u>	32	GPIO32 to GPIO63 falling edge interrupt enable register These registers are used to enable the condition for falling edge triggered interrupt.
10000668	<u>GINT_FEDGE_2</u>	32	GPIO64 to GPIO95 falling edge interrupt enable register These registers are used to enable the condition of falling edge triggered interrupt.
10000670	<u>GINT_HLVL_0</u>	32	GPIO0 to GPIO31 high level interrupt enable register These registers are used to enable the condition of high level triggered interrupt. The bit in this register and the corresponded bit in GINT_LLVL_0 can not be set to 1 at the same time.
10000674	<u>GINT_HLVL_1</u>	32	GPIO32 to GPIO63 high level interrupt enable register These registers are used to enable the condition of high level triggered interrupt. The bit in this register and the corresponded bit in GINT_LLVL_1 can not be set to 1 at the same time.
10000678	<u>GINT_HLVL_2</u>	32	GPIO64 to GPIO95 high level interrupt enable register These registers are used to enable the condition of high level triggered interrupt. The bit in this register and the corresponded bit in GINT_LLVL_2 can not be set to 1 at the same time.
10000680	<u>GINT_LLVL_0</u>	32	GPIO0 to GPIO31 low level interrupt enable register These registers are used to enable the condition of low level triggered interrupt. The bit in this register and the corresponded bit in GINT_HLVL_0 can not be set to 1 at the same time.
10000684	<u>GINT_LLVL_1</u>	32	GPIO32 to GPIO63 low level interrupt enable register These registers are used to enable the condition of low level triggered interrupt. The bit in this register and the corresponded bit in GINT_HLVL_1 can not be set to 1 at the same time.
10000688	<u>GINT_LLVL_2</u>	32	GPIO64 to GPIO95 low level interrupt enable register These registers are used to enable the condition of low level triggered interrupt. The bit in this register and the corresponded bit in GINT_HLVL_2 can not be set to 1 at the same time.
10000690	<u>GINT_STAT_0</u>	32	GPIO0 to GPIO31 interrupt status register These registers are used to record the GPIO current interrupt status.
10000694	<u>GINT_STAT_1</u>	32	GPIO32 to GPIO63 interrupt status register These registers are used to record the GPIO current interrupt status.
10000698	<u>GINT_STAT_2</u>	32	GPIO64 to GPIO95 interrupt status register These registers are used to record the GPIO current interrupt status.
100006A0	<u>GINT_EDGE_0</u>	32	GPIO0 to GPIO31 edge status register These registers are used to record the GPIO current interrupt's edge status. These registers are useful only in edge triggered interrupt.
100006A4	<u>GINT_EDGE_1</u>	32	GPIO32 to GPIO63 edge status register These registers are used to record the GPIO current interrupt's edge status. These registers are useful only in edge triggered interrupt.
100006A8	<u>GINT_EDGE_2</u>	32	GPIO64 to GPIO95 edge status register These registers are used to record the GPIO current interrupt's edge status. These registers are useful only in edge triggered interrupt.

10000600 **GPIO_CTRL_0** GPIO0 to GPIO31 direction control register 0000000
0

Bit	31	30	29	28	27	26	25	24	23	22	21	20	19	18	17	16
Name	GPIOCTRL0[31:16]															
Type	RW															
Reset	0	0	0	0	0	0	0	0	0	0	0	0	0	0	0	0
Bit	15	14	13	12	11	10	9	8	7	6	5	4	3	2	1	0
Name	GPIOCTRL0[15:0]															
Type	RW															
Reset	0	0	0	0	0	0	0	0	0	0	0	0	0	0	0	0

Bit(s)	Name	Description
31:0	GPIOCTRL0	GPIO Pin Direction 0: GPIO input mode 1: GPIO output mode

10000604 **GPIO_CTRL_1** GPIO32 to GPIO63 direction control register 0000000
0

Bit	31	30	29	28	27	26	25	24	23	22	21	20	19	18	17	16
Name	GPIOCTRL1[31:16]															
Type	RW															
Reset	0	0	0	0	0	0	0	0	0	0	0	0	0	0	0	0
Bit	15	14	13	12	11	10	9	8	7	6	5	4	3	2	1	0
Name	GPIOCTRL1[15:0]															
Type	RW															
Reset	0	0	0	0	0	0	0	0	0	0	0	0	0	0	0	0

Bit(s)	Name	Description
31:0	GPIOCTRL1	GPIO Pin Direction 0: GPIO input mode 1: GPIO output mode

10000608 **GPIO_CTRL_2** GPIO64 to GPIO95 direction control register 0000000
0

Bit	31	30	29	28	27	26	25	24	23	22	21	20	19	18	17	16
Name	GPIOCTRL2[31:16]															
Type	RW															
Reset	0	0	0	0	0	0	0	0	0	0	0	0	0	0	0	0
Bit	15	14	13	12	11	10	9	8	7	6	5	4	3	2	1	0
Name	GPIOCTRL2[15:0]															
Type	RW															
Reset	0	0	0	0	0	0	0	0	0	0	0	0	0	0	0	0

Bit(s)	Name	Description
31:0	GPIOCTRL2	GPIO Pin Direction 0: GPIO input mode 1: GPIO output mode

10000610 **GPIO_POL_0** GPIO0 to GPIO31 polarity control register 0000000
0

Bit	31	30	29	28	27	26	25	24	23	22	21	20	19	18	17	16
Name	GPIOPOL0[31:16]															
Type	RW															

Reset	0	0	0	0	0	0	0	0	0	0	0	0	0	0	0	0
Bit	15	14	13	12	11	10	9	8	7	6	5	4	3	2	1	0
Name	GPIOPOL0[15:0]															
Type	RW															
Reset	0	0	0	0	0	0	0	0	0	0	0	0	0	0	0	0

Bit(s)	Name	Description
31:0	GPIOPOL0	GPIO Data Polarity 0: Data is non-inverted 1: Data is inverted

10000614 **GPIO_POL_1** GPIO32 to GPIO63 polarity control register 0000000
0

Bit	31	30	29	28	27	26	25	24	23	22	21	20	19	18	17	16
Name	GPIOPOL1[31:16]															
Type	RW															
Reset	0	0	0	0	0	0	0	0	0	0	0	0	0	0	0	0
Bit	15	14	13	12	11	10	9	8	7	6	5	4	3	2	1	0
Name	GPIOPOL1[15:0]															
Type	RW															
Reset	0	0	0	0	0	0	0	0	0	0	0	0	0	0	0	0

Bit(s)	Name	Description
31:0	GPIOPOL1	GPIO Data Polarity 0: Data is non-inverted 1: Data is inverted

10000618 **GPIO_POL_2** GPIO64 to GPIO95 polarity control register 0000000
0

Bit	31	30	29	28	27	26	25	24	23	22	21	20	19	18	17	16
Name	GPIOPOL2[31:16]															
Type	RW															
Reset	0	0	0	0	0	0	0	0	0	0	0	0	0	0	0	0
Bit	15	14	13	12	11	10	9	8	7	6	5	4	3	2	1	0
Name	GPIOPOL2[15:0]															
Type	RW															
Reset	0	0	0	0	0	0	0	0	0	0	0	0	0	0	0	0

Bit(s)	Name	Description
31:0	GPIOPOL2	GPIO Data Polarity 0: Data is non-inverted 1: Data is inverted

10000620 **GPIO_DATA_0** GPIO0 to GPIO31 data register 0000000
0

Bit	31	30	29	28	27	26	25	24	23	22	21	20	19	18	17	16
Name	GPIODATA0[31:16]															
Type	RW															
Reset	0	0	0	0	0	0	0	0	0	0	0	0	0	0	0	0
Bit	15	14	13	12	11	10	9	8	7	6	5	4	3	2	1	0
Name	GPIODATA0[15:0]															
Type	RW															
Reset	0	0	0	0	0	0	0	0	0	0	0	0	0	0	0	0

Bit(s)	Name	Description
31:0	GPIODATA0	GPIO Data

10000624 GPIO_DATA 1 GPIO32 to GPIO63 data register 0000000
0

Bit	31	30	29	28	27	26	25	24	23	22	21	20	19	18	17	16
Name	GPIODATA1[31:16]															
Type	RW															
Reset	0	0	0	0	0	0	0	0	0	0	0	0	0	0	0	0
Bit	15	14	13	12	11	10	9	8	7	6	5	4	3	2	1	0
Name	GPIODATA1[15:0]															
Type	RW															
Reset	0	0	0	0	0	0	0	0	0	0	0	0	0	0	0	0

Bit(s)	Name	Description
31:0	GPIODATA1	GPIO Data

10000628 GPIO_DATA 2 GPIO64 to GPIO95 data register 0000000
0

Bit	31	30	29	28	27	26	25	24	23	22	21	20	19	18	17	16
Name	GPIODATA2[31:16]															
Type	RW															
Reset	0	0	0	0	0	0	0	0	0	0	0	0	0	0	0	0
Bit	15	14	13	12	11	10	9	8	7	6	5	4	3	2	1	0
Name	GPIODATA2[15:0]															
Type	RW															
Reset	0	0	0	0	0	0	0	0	0	0	0	0	0	0	0	0

Bit(s)	Name	Description
31:0	GPIODATA2	GPIO Data

10000630 GPIO_DSET_0 GPIO0 to GPIO31 data set register FFFFFFFF
FF

Bit	31	30	29	28	27	26	25	24	23	22	21	20	19	18	17	16
Name	GPIODSET0[31:16]															
Type	WO															
Reset	1	1	1	1	1	1	1	1	1	1	1	1	1	1	1	1
Bit	15	14	13	12	11	10	9	8	7	6	5	4	3	2	1	0
Name	GPIODSET0[15:0]															
Type	WO															
Reset	1	1	1	1	1	1	1	1	1	1	1	1	1	1	1	1

Bit(s)	Name	Description
31:0	GPIODSET0	GPIO Data Set 1: Set the GPIO_DATA_0 register 0: No effect

10000634 GPIO_DSET_1 GPIO32 to GPIO63 data set register FFFFFFFF
FF

Bit	31	30	29	28	27	26	25	24	23	22	21	20	19	18	17	16
Name	GPIODSET1[31:16]															
Type	WO															
Reset	1	1	1	1	1	1	1	1	1	1	1	1	1	1	1	1
Bit	15	14	13	12	11	10	9	8	7	6	5	4	3	2	1	0
Name	GPIODSET1[15:0]															
Type	WO															

Reset	1	1	1	1	1	1	1	1	1	1	1	1	1	1	1	1	1
--------------	---	---	---	---	---	---	---	---	---	---	---	---	---	---	---	---	---

Bit(s)	Name	Description
31:0	GPIODSET1	GPIO Data Set 1: Set the GPIO_DATA_1 register 0: No effect

10000638 **GPIO DSET 2** **GPIO64 to GPIO95 data set register** **FFFFFF**
FF

Bit	31	30	29	28	27	26	25	24	23	22	21	20	19	18	17	16
Name	GPIODSET2[31:16]															
Type	WO															
Reset	1	1	1	1	1	1	1	1	1	1	1	1	1	1	1	1
Bit	15	14	13	12	11	10	9	8	7	6	5	4	3	2	1	0
Name	GPIODSET2[15:0]															
Type	WO															
Reset	1	1	1	1	1	1	1	1	1	1	1	1	1	1	1	1

Bit(s)	Name	Description
31:0	GPIODSET2	GPIO Data Set 1: Set the GPIO_DATA_2 register 0: No effect

10000640 **GPIO DCLR 0** **GPIO0 to GPIO31 data clear register** **FFFFFF**
FF

Bit	31	30	29	28	27	26	25	24	23	22	21	20	19	18	17	16
Name	GPIODCLR0[31:16]															
Type	WO															
Reset	1	1	1	1	1	1	1	1	1	1	1	1	1	1	1	1
Bit	15	14	13	12	11	10	9	8	7	6	5	4	3	2	1	0
Name	GPIODCLR0[15:0]															
Type	WO															
Reset	1	1	1	1	1	1	1	1	1	1	1	1	1	1	1	1

Bit(s)	Name	Description
31:0	GPIODCLR0	GPIO Data Clear 1: Clear the GPIO_DATA_0 register 0: No effect

10000644 **GPIO DCLR 1** **GPIO32 to GPIO63 data clear register** **FFFFFF**
FF

Bit	31	30	29	28	27	26	25	24	23	22	21	20	19	18	17	16
Name	GPIODCLR1[31:16]															
Type	WO															
Reset	1	1	1	1	1	1	1	1	1	1	1	1	1	1	1	1
Bit	15	14	13	12	11	10	9	8	7	6	5	4	3	2	1	0
Name	GPIODCLR1[15:0]															
Type	WO															
Reset	1	1	1	1	1	1	1	1	1	1	1	1	1	1	1	1

Bit(s)	Name	Description
31:0	GPIODCLR1	GPIO Data Clear 1: Clear the GPIO_DATA_1 register 0: No effect

10000648 GPIO_DCLR 2 GPIO64 to GPIO95 data clear register FFFFFFFF
FF

Bit	31	30	29	28	27	26	25	24	23	22	21	20	19	18	17	16
Name	GPIODCLR2[31:16]															
Type	WO															
Reset	1	1	1	1	1	1	1	1	1	1	1	1	1	1	1	1
Bit	15	14	13	12	11	10	9	8	7	6	5	4	3	2	1	0
Name	GPIODCLR2[15:0]															
Type	WO															
Reset	1	1	1	1	1	1	1	1	1	1	1	1	1	1	1	1

Bit(s)	Name	Description
31:0	GPIODCLR2	GPIO Data Clear 1: Clear the GPIO_DATA_2 register 0: No effect

10000650 GINT_REDEGE 0 GPIO0 to GPIO31 rising edge interrupt enable register 00000000
0

Bit	31	30	29	28	27	26	25	24	23	22	21	20	19	18	17	16
Name	GINTREDGE0[31:16]															
Type	RW															
Reset	0	0	0	0	0	0	0	0	0	0	0	0	0	0	0	0
Bit	15	14	13	12	11	10	9	8	7	6	5	4	3	2	1	0
Name	GINTREDGE0[15:0]															
Type	RW															
Reset	0	0	0	0	0	0	0	0	0	0	0	0	0	0	0	0

Bit(s)	Name	Description
31:0	GINTREDGE0	GPIO Rising Edge Interrupt Enable 1: Enable rising edge triggered 0: Disable rising edge triggered

10000654 GINT_REDEGE 1 GPIO32 to GPIO63 rising edge interrupt enable register 00000000
0

Bit	31	30	29	28	27	26	25	24	23	22	21	20	19	18	17	16
Name	GINTREDGE1[31:16]															
Type	RW															
Reset	0	0	0	0	0	0	0	0	0	0	0	0	0	0	0	0
Bit	15	14	13	12	11	10	9	8	7	6	5	4	3	2	1	0
Name	GINTREDGE1[15:0]															
Type	RW															
Reset	0	0	0	0	0	0	0	0	0	0	0	0	0	0	0	0

Bit(s)	Name	Description
31:0	GINTREDGE1	GPIO Rising Edge Interrupt Enable 1: Enable rising edge triggered 0: Disable rising edge triggered

10000658 GINT_REDEGE 2 GPIO64 to GPIO95 rising edge interrupt enable register 00000000
0

Bit	31	30	29	28	27	26	25	24	23	22	21	20	19	18	17	16
Name	GINTREDGE2[31:16]															
Type	RW															
Reset	0	0	0	0	0	0	0	0	0	0	0	0	0	0	0	0

Bit(s)	Name	Description
		0: Disable falling edge triggered

10000670 **GINT_HLVL_0** **GPIO0 to GPIO31 high level interrupt enable register** **0000000**
0

Bit	31	30	29	28	27	26	25	24	23	22	21	20	19	18	17	16
Name	GINTHLVL0[31:16]															
Type	RW															
Reset	0	0	0	0	0	0	0	0	0	0	0	0	0	0	0	0
Bit	15	14	13	12	11	10	9	8	7	6	5	4	3	2	1	0
Name	GINTHLVL0[15:0]															
Type	RW															
Reset	0	0	0	0	0	0	0	0	0	0	0	0	0	0	0	0

Bit(s)	Name	Description
31:0	GINTHLVL0	GPIO High Level Interrupt Enable 1: Enable high level triggered 0: Disable high level triggered

10000674 **GINT_HLVL_1** **GPIO32 to GPIO63 high level interrupt enable register** **0000000**
0

Bit	31	30	29	28	27	26	25	24	23	22	21	20	19	18	17	16
Name	GINTHLVL1[31:16]															
Type	RW															
Reset	0	0	0	0	0	0	0	0	0	0	0	0	0	0	0	0
Bit	15	14	13	12	11	10	9	8	7	6	5	4	3	2	1	0
Name	GINTHLVL1[15:0]															
Type	RW															
Reset	0	0	0	0	0	0	0	0	0	0	0	0	0	0	0	0

Bit(s)	Name	Description
31:0	GINTHLVL1	GPIO High Level Interrupt Enable 1: Enable high level triggered 0: Disable high level triggered

10000678 **GINT_HLVL_2** **GPIO64 to GPIO95 high level interrupt enable register** **0000000**
0

Bit	31	30	29	28	27	26	25	24	23	22	21	20	19	18	17	16
Name	GINTHLVL2[31:16]															
Type	RW															
Reset	0	0	0	0	0	0	0	0	0	0	0	0	0	0	0	0
Bit	15	14	13	12	11	10	9	8	7	6	5	4	3	2	1	0
Name	GINTHLVL2[15:0]															
Type	RW															
Reset	0	0	0	0	0	0	0	0	0	0	0	0	0	0	0	0

Bit(s)	Name	Description
31:0	GINTHLVL2	GPIO High Level Interrupt Enable 1: Enable high level triggered 0: Disable high level triggered

10000680 **GINT_LLVL_0** **GPIO0 to GPIO31 low level interrupt enable register** **0000000**
0

Bit	31	30	29	28	27	26	25	24	23	22	21	20	19	18	17	16
Name	GINTLLVL0[31:16]															
Type	RW															
Reset	0	0	0	0	0	0	0	0	0	0	0	0	0	0	0	0
Bit	15	14	13	12	11	10	9	8	7	6	5	4	3	2	1	0
Name	GINTLLVL0[15:0]															
Type	RW															
Reset	0	0	0	0	0	0	0	0	0	0	0	0	0	0	0	0

Bit(s)	Name	Description
31:0	GINTLLVL0	GPIO Low Level Interrupt Enable 1: Enable low level triggered 0: Disable low level triggered

10000684 **GINT_LLVL_1** GPIO32 to GPIO63 low level interrupt enable register 0000000
0

Bit	31	30	29	28	27	26	25	24	23	22	21	20	19	18	17	16
Name	GINTLLVL1[31:16]															
Type	RW															
Reset	0	0	0	0	0	0	0	0	0	0	0	0	0	0	0	0
Bit	15	14	13	12	11	10	9	8	7	6	5	4	3	2	1	0
Name	GINTLLVL1[15:0]															
Type	RW															
Reset	0	0	0	0	0	0	0	0	0	0	0	0	0	0	0	0

Bit(s)	Name	Description
31:0	GINTLLVL1	GPIO Low Level Interrupt Enable 1: Enable low level triggered 0: Disable low level triggered

10000688 **GINT_LLVL_2** GPIO64 to GPIO95 low level interrupt enable register 0000000
0

Bit	31	30	29	28	27	26	25	24	23	22	21	20	19	18	17	16
Name	GINTLLVL2[31:16]															
Type	RW															
Reset	0	0	0	0	0	0	0	0	0	0	0	0	0	0	0	0
Bit	15	14	13	12	11	10	9	8	7	6	5	4	3	2	1	0
Name	GINTLLVL2[15:0]															
Type	RW															
Reset	0	0	0	0	0	0	0	0	0	0	0	0	0	0	0	0

Bit(s)	Name	Description
31:0	GINTLLVL2	GPIO Low Level Interrupt Enable 1: Enable low level triggered 0: Disable low level triggered

10000690 **GINT_STAT_0** GPIO0 to GPIO31 interrupt status register 0000000
0

Bit	31	30	29	28	27	26	25	24	23	22	21	20	19	18	17	16
Name	GINTSTAT0[31:16]															
Type	W1C															
Reset	0	0	0	0	0	0	0	0	0	0	0	0	0	0	0	0
Bit	15	14	13	12	11	10	9	8	7	6	5	4	3	2	1	0
Name	GINTSTAT0[15:0]															
Type	W1C															
Reset	0	0	0	0	0	0	0	0	0	0	0	0	0	0	0	0

Bit(s)	Name	Description
31:0	GINTSTAT0	GPIO Interrupt Status 1: Interrupt is detected 0: Interrupt is not detected

10000694 GINT_STAT_1 GPIO32 to GPIO63 interrupt status register 0000000
0

Bit	31	30	29	28	27	26	25	24	23	22	21	20	19	18	17	16
Name	GINTSTAT1[31:16]															
Type	W1C															
Reset	0	0	0	0	0	0	0	0	0	0	0	0	0	0	0	0
Bit	15	14	13	12	11	10	9	8	7	6	5	4	3	2	1	0
Name	GINTSTAT1[15:0]															
Type	W1C															
Reset	0	0	0	0	0	0	0	0	0	0	0	0	0	0	0	0

Bit(s)	Name	Description
31:0	GINTSTAT1	GPIO Interrupt Status 1: Interrupt is detected 0: Interrupt is not detected

10000698 GINT_STAT_2 GPIO64 to GPIO95 interrupt status register 0000000
0

Bit	31	30	29	28	27	26	25	24	23	22	21	20	19	18	17	16
Name	GINTSTAT2[31:16]															
Type	W1C															
Reset	0	0	0	0	0	0	0	0	0	0	0	0	0	0	0	0
Bit	15	14	13	12	11	10	9	8	7	6	5	4	3	2	1	0
Name	GINTSTAT2[15:0]															
Type	W1C															
Reset	0	0	0	0	0	0	0	0	0	0	0	0	0	0	0	0

Bit(s)	Name	Description
31:0	GINTSTAT2	GPIO Interrupt Status 1: Interrupt is detected 0: Interrupt is not detected

100006A0 GINT_EDGE_0 GPIO0 to GPIO31 edge status register 0000000
0

Bit	31	30	29	28	27	26	25	24	23	22	21	20	19	18	17	16
Name	GINTEDGE0[31:16]															
Type	W1C															
Reset	0	0	0	0	0	0	0	0	0	0	0	0	0	0	0	0
Bit	15	14	13	12	11	10	9	8	7	6	5	4	3	2	1	0
Name	GINTEDGE0[15:0]															
Type	W1C															
Reset	0	0	0	0	0	0	0	0	0	0	0	0	0	0	0	0

Bit(s)	Name	Description
31:0	GINTEDGE0	GPIO Interrupt Edge Status 1: Rising edge 0: Falling edge

100006A4 GINT_EDGE
1 GPIO32 to GPIO63 edge status register 0000000
0

Bit	31	30	29	28	27	26	25	24	23	22	21	20	19	18	17	16
Name	GINTEDGE1[31:16]															
Type	W1C															
Reset	0	0	0	0	0	0	0	0	0	0	0	0	0	0	0	0
Bit	15	14	13	12	11	10	9	8	7	6	5	4	3	2	1	0
Name	GINTEDGE1[15:0]															
Type	W1C															
Reset	0	0	0	0	0	0	0	0	0	0	0	0	0	0	0	0

Bit(s)	Name	Description
31:0	GINTEDGE1	GPIO Interrupt Edge Status 1: Rising edge 0: Falling edge

100006A8 GINT_EDGE
2 GPIO64 to GPIO95 edge status register 0000000
0

Bit	31	30	29	28	27	26	25	24	23	22	21	20	19	18	17	16
Name	GINTEDGE2[31:16]															
Type	W1C															
Reset	0	0	0	0	0	0	0	0	0	0	0	0	0	0	0	0
Bit	15	14	13	12	11	10	9	8	7	6	5	4	3	2	1	0
Name	GINTEDGE2[15:0]															
Type	W1C															
Reset	0	0	0	0	0	0	0	0	0	0	0	0	0	0	0	0

Bit(s)	Name	Description
31:0	GINTEDGE2	GPIO Interrupt Edge Status 1: Rising edge 0: Falling edge

5.9 SPI Slave

5.9.1 SPI Slave Control

spis_intf Changes LOG

Revision	Date	Author	Change Log
0.1	2013/9/23	Kaiping Yen	Initialization

Module name: spis_intf Base address: (+0h)

Address	Name	Width	Register Function
00000000	REG00	32	SPI Slave Register 00
00000004	REG01	32	SPI Slave Register 01
00000008	REG02	32	SPI Slave Register 02
0000000C	REG03	32	SPI Slave Register 03
00000010	REG04	32	SPI Slave Register 04

00000000 **REG00** **SPI Slave Register 00** **00000000**
0

Bit	31	30	29	28	27	26	25	24	23	22	21	20	19	18	17	16
Name	bus_read_data[31:16]															
Type	RO															
Reset	0	0	0	0	0	0	0	0	0	0	0	0	0	0	0	0
Bit	15	14	13	12	11	10	9	8	7	6	5	4	3	2	1	0
Name	bus_read_data[15:0]															
Type	RO															
Reset	0	0	0	0	0	0	0	0	0	0	0	0	0	0	0	0

Bit(s)	Name	Description
31:0	bus_read_data	SPI Slave Register 00 for bus read data

00000004 **REG01** **SPI Slave Register 01** **00000000**
0

Bit	31	30	29	28	27	26	25	24	23	22	21	20	19	18	17	16
Name	bus_write_data[31:16]															
Type	RW															
Reset	0	0	0	0	0	0	0	0	0	0	0	0	0	0	0	0
Bit	15	14	13	12	11	10	9	8	7	6	5	4	3	2	1	0
Name	bus_write_data[15:0]															
Type	RW															
Reset	0	0	0	0	0	0	0	0	0	0	0	0	0	0	0	0

Bit(s)	Name	Description
31:0	bus_write_data	SPI Slave Register 01 for bus write data

00000008 **REG02** **SPI Slave Register 02** **00000000**
0

Bit	31	30	29	28	27	26	25	24	23	22	21	20	19	18	17	16
Name	bus_address[31:16]															
Type	RW															
Reset	0	0	0	0	0	0	0	0	0	0	0	0	0	0	0	0

Bit	15	14	13	12	11	10	9	8	7	6	5	4	3	2	1	0
Name	bus_address[15:0]															
Type	RW															
Reset	0	0	0	0	0	0	0	0	0	0	0	0	0	0	0	0

Bit(s)	Name	Description
31:0	bus_address	SPI Slave Register 02 for bus address This address must be physical address

0000000C REG03 SPI Slave Register 03 00000000

Bit	31	30	29	28	27	26	25	24	23	22	21	20	19	18	17	16
Name	reg03_31_5[26:11]															
Type	RW															
Reset	0	0	0	0	0	0	0	0	0	0	0	0	0	0	0	0
Bit	15	14	13	12	11	10	9	8	7	6	5	4	3	2	1	0
Name	reg03_31_5[10:0]											bus_pb_rb_sel	reg03_3	bus_size	bus_r_w	
Type	RW											RW	RW	RW	RW	
Reset	0	0	0	0	0	0	0	0	0	0	0	0	0	0	0	0

Bit(s)	Name	Description
31:5	reg03_31_5	reg03[31:5] reserved bit
4	bus_pb_rb_sel	Bus interface selection 0: Bus transaction is asserted by Rbus master interface, can access DRAM and peripheral registers 1: Bus transaction is asserted by Pbus master interface, can peripheral registers only
3	reg03_3	reg03[3] reserved bit
2:1	bus_size	Bus access size 00: reserved 01: reserved 10: word (4bytes) 11: reserved
0	bus_r_w	Bus access type 0: read 1: write

00000010 REG04 SPI Slave Register 04 00000000

Bit	31	30	29	28	27	26	25	24	23	22	21	20	19	18	17	16
Name																
Type																
Reset																
Bit	15	14	13	12	11	10	9	8	7	6	5	4	3	2	1	0
Name																bus_busy
Type																RO
Reset																0

Bit(s)	Name	Description
0	bus_busy	Bus (Internal Rbus/Pbus Master) interface status 0: SPIS bus interface is idle for next access command 1: SPIS bus interface is busy

5.9.2 Registers

spis_pbslv Changes LOG

Revision	Date	Author	Change Log
0.1	2013/9/23	Kaiping Yen	Initialization

Module name: spis_pbslv Base address: (+10000700h)

Address	Name	Width	Register Function
10000700	SPIS_REG0	32	SPI Slave Register 0
10000704	SPIS_REG1	32	SPI Slave Register 1
10000708	SPIS_REG2	32	SPI Slave Register 2
1000070C	SPIS_REG3	32	SPI Slave Register 3
10000710	SPIS_REG4	32	SPI Slave Register 4
10000740	SPIS_CFG	32	SPI Slave Configuration

10000700 SPIS_REG0 SPI Slave Register 0 00000000

Bit	31	30	29	28	27	26	25	24	23	22	21	20	19	18	17	16
Name	spis_reg0[31:16]															
Type	RO															
Reset	0	0	0	0	0	0	0	0	0	0	0	0	0	0	0	0
Bit	15	14	13	12	11	10	9	8	7	6	5	4	3	2	1	0
Name	spis_reg0[15:0]															
Type	RO															
Reset	0	0	0	0	0	0	0	0	0	0	0	0	0	0	0	0

Bit(s)	Name	Description
31:0	spis_reg0	SPI Slave Register 0

10000704 SPIS_REG1 SPI Slave Register 1 00000000

Bit	31	30	29	28	27	26	25	24	23	22	21	20	19	18	17	16
Name	spis_reg1[31:16]															
Type	RO															
Reset	0	0	0	0	0	0	0	0	0	0	0	0	0	0	0	0
Bit	15	14	13	12	11	10	9	8	7	6	5	4	3	2	1	0
Name	spis_reg1[15:0]															
Type	RO															
Reset	0	0	0	0	0	0	0	0	0	0	0	0	0	0	0	0

Bit(s)	Name	Description
31:0	spis_reg1	SPI Slave Register 1

10000708 SPIS_REG2 SPI Slave Register 2 00000000

Bit	31	30	29	28	27	26	25	24	23	22	21	20	19	18	17	16
Name	spis_reg2[31:16]															
Type	RO															
Reset	0	0	0	0	0	0	0	0	0	0	0	0	0	0	0	0
Bit	15	14	13	12	11	10	9	8	7	6	5	4	3	2	1	0

Name	spis_reg2[15:0]															
Type	RO															
Reset	0	0	0	0	0	0	0	0	0	0	0	0	0	0	0	0

Bit(s)	Name	Description
31:0	spis_reg2	SPI Slave Register 2

1000070C **SPIS_REG3** **SPI Slave Register 3** **0000000**
0

Bit	31	30	29	28	27	26	25	24	23	22	21	20	19	18	17	16
Name	spis_reg3[31:16]															
Type	RO															
Reset	0	0	0	0	0	0	0	0	0	0	0	0	0	0	0	0
Bit	15	14	13	12	11	10	9	8	7	6	5	4	3	2	1	0
Name	spis_reg3[15:0]															
Type	RO															
Reset	0	0	0	0	0	0	0	0	0	0	0	0	0	0	0	0

Bit(s)	Name	Description
31:0	spis_reg3	SPI Slave Register 3

10000710 **SPIS_REG4** **SPI Slave Register 4** **0000000**
0

Bit	31	30	29	28	27	26	25	24	23	22	21	20	19	18	17	16
Name	spis_reg4[31:16]															
Type	RO															
Reset	0	0	0	0	0	0	0	0	0	0	0	0	0	0	0	0
Bit	15	14	13	12	11	10	9	8	7	6	5	4	3	2	1	0
Name	spis_reg4[15:0]															
Type	RO															
Reset	0	0	0	0	0	0	0	0	0	0	0	0	0	0	0	0

Bit(s)	Name	Description
31:0	spis_reg4	SPI Slave Register 4

10000740 **SPIS_CFG** **SPI Slave Configuration** **0000000**
0

Bit	31	30	29	28	27	26	25	24	23	22	21	20	19	18	17	16
Name																
Type																
Reset																
Bit	15	14	13	12	11	10	9	8	7	6	5	4	3	2	1	0
Name																spis_mode
Type																RW
Reset															0	0

Bit(s)	Name	Description
1:0	spis_mode	SPI slave clock polarity and phase configuration 2'b00: CPOL=0, CPHA=0 2'b01: CPOL=0, CPHA=1 2'b10: CPOL=1, CPHA=0 2'b11: CPOL=1, CPHA=1

5.10 I²C Controller

5.10.1 Features

- Programmable I²C bus clock rate
- Supports the Synchronous Inter-Integrated Circuits (I²C) serial protocol
- Bi-directional data transfer
- Programmable address width up to 8 bits
- Sequential byte read or write capability
- Device address and data address can be transmitted for device, page and address selection
- Supports Standard mode and Fast mode

5.10.2 List of Registers
I2C Changes LOG

Revision	Date	Author	Change Log
0.1	2012/10/3	Evan Chou	Initialization

Module name: I2C Base address: (+10000900h)

Address	Name	Width	Register Function
10000908	<u>SM0CFG0</u>	32	SERIAL INTERFACE MASTER 0 CONFIG 0 REGISTER
10000910	<u>SM0DOUT</u>	32	SERIAL INTERFACE MASTER 0 DATAOUT REGISTER
10000914	<u>SM0DIN</u>	32	SERIAL INTERFACE MASTER 0 DATAIN REGISTER
10000918	<u>SM0ST</u>	32	SERIAL INTERFACE MASTER 0 STATUS REGISTER
1000091C	<u>SM0AUTO</u>	32	SERIAL INTERFACE MASTER 0 AUTO-MODE REGISTER
10000920	<u>SM0CFG1</u>	32	SERIAL INTERFACE MASTER 0 CONFIG 1 REGISTER
10000928	<u>SM0CFG2</u>	32	SERIAL INTERFACE MASTER 0 CONFIG 2 REGISTER
10000940	<u>SM0CTL0</u>	32	Serial interface master 0 control 0 register
10000944	<u>SM0CTL1</u>	32	Serial interface master 0 control 1 register
10000950	<u>SM0D0</u>	32	Serial interface master 0 data 0 register
10000954	<u>SM0D1</u>	32	Serial interface master 0 data 1 register
1000095C	<u>PINTEN</u>	32	Peripheral interrupt enable register
10000960	<u>PINTST</u>	32	Peripheral interrupt status register
10000964	<u>PINTCL</u>	32	Peripheral interrupt clear register

10000908 SM0CFG0 SERIAL INTERFACE MASTER 0 CONFIG 0 REGISTER 00000000

Bit	31	30	29	28	27	26	25	24	23	22	21	20	19	18	17	16
Name																
Type																
Reset																
Bit	15	14	13	12	11	10	9	8	7	6	5	4	3	2	1	0
Name												SM0_DEVADDR				
Type												RW				
Reset										0	0	0	0	0	0	0

Bit(s)	Name	Description
6:0	SM0_DEVADDR	Device address for transmission

10000910 **SM0DOUT** **SERIAL INTERFACE MASTER 0 DATAOUT REGISTER** **0000000**
0

Bit	31	30	29	28	27	26	25	24	23	22	21	20	19	18	17	16		
Name																		
Type																		
Reset																		
Bit	15	14	13	12	11	10	9	8	7	6	5	4	3	2	1	0		
Name									SM0_DATAOUT									
Type									RW									
Reset									0	0	0	0	0	0	0	0		

Bit(s)	Name	Description
7:0	SM0_DATAOUT	Data out register for auto mode

10000914 **SM0DIN** **SERIAL INTERFACE MASTER 0 DATAIN REGISTER** **0000000**
0

Bit	31	30	29	28	27	26	25	24	23	22	21	20	19	18	17	16		
Name																		
Type																		
Reset																		
Bit	15	14	13	12	11	10	9	8	7	6	5	4	3	2	1	0		
Name									SM0_DATAIN									
Type									RO									
Reset									0	0	0	0	0	0	0	0		

Bit(s)	Name	Description
7:0	SM0_DATAIN	Data in register for auto mode

10000918 **SM0ST** **SERIAL INTERFACE MASTER 0 STATUS REGISTER** **0000000**
2

Bit	31	30	29	28	27	26	25	24	23	22	21	20	19	18	17	16
Name																
Type																
Reset																
Bit	15	14	13	12	11	10	9	8	7	6	5	4	3	2	1	0
Name														SM0_RDATA_RDY	SM0_WDATA_EMPTY	SM0_BUSY
Type														RW	RW	RO
Reset														0	1	0

Bit(s)	Name	Description
2	SM0_RDATA_RDY	I2C read data is ready
1	SM0_WDATA_EMPTY	I2C data output register is empty
0	SM0_BUSY	State machine is busy

1000091C **SM0AUTO** **SERIAL INTERFACE MASTER 0 AUTO-MODE REGISTER** **0000000**
0

Bit	31	30	29	28	27	26	25	24	23	22	21	20	19	18	17	16
Name																
Type																

Reset																
Bit	15	14	13	12	11	10	9	8	7	6	5	4	3	2	1	0
Name																SM0_START_RW
Type																RW
Reset																0

Bit(s)	Name	Description
0	SM0_START_RW	Written with 1 to start a read transaction, and 0 to start a write transaction. This bit is only valid at auto mode.

10000920 **SM0CFG1** SERIAL INTERFACE MASTER 0 CONFIG 1 REGISTER 00000000

Bit	31	30	29	28	27	26	25	24	23	22	21	20	19	18	17	16
Name																
Type																
Reset																
Bit	15	14	13	12	11	10	9	8	7	6	5	4	3	2	1	0
Name																SM0_BYTECNT
Type																RW
Reset											0	0	0	0	0	0

Bit(s)	Name	Description
5:0	SM0_BYTECNT	The value + 1 indicateds the number of data bytes for sequential reads/writes. (word address is included in data bytes)

10000928 **SM0CFG2** SERIAL INTERFACE MASTER 0 CONFIG 2 REGISTER 00000000

Bit	31	30	29	28	27	26	25	24	23	22	21	20	19	18	17	16
Name																
Type																
Reset																
Bit	15	14	13	12	11	10	9	8	7	6	5	4	3	2	1	0
Name																SM0_IS_AUTOMODE
Type																RW
Reset																0

Bit(s)	Name	Description
0	SM0_IS_AUTOMODE	Set 1 to configure auto mode

10000940 **SM0CTL0** Serial interface master 0 control 0 register 00008000

Bit	31	30	29	28	27	26	25	24	23	22	21	20	19	18	17	16
Name	SM0_DRIVE			RESV0	SM0_CLK_DIV											
Type	RW			RO	RW											
Reset	0	0	0	0	0	0	0	0	0	0	0	0	0	0	0	0

Bit	15	14	13	12	11	10	9	8	7	6	5	4	3	2	1	0
Name	SIF_VSYN C	RE SV1	SM0_VSY NC_MODE	RESV2								SM 0_C S_S TAT US	SM 0_S CL_ ST AT E	SM 0_S DA_ ST AT E	SM 0_EN	SM 0_S CL_ ST RE CH
Type	RO	RO	RW	RO								RO	RO	RO	RW	RW
Reset	1	0	0	0	0	0	0	0	0	0	0	0	0	0	0	0

Bit(s)	Name	Description
31	SM0_ODRAIN	Open-drain output configuration 0: When SIF output is logic 1, the output is pulled high by outer devices. SIF output is open-drained. 1: When SIF output is logic 1, the output is pulled high by SIF master 0.
30:28	RESV0	
27:16	SM0_CLK_DIV	SIF master 0 clock divide value This is used to set the divider to generate expected SCL.
15	SIF_VSYNC	
14	RESV1	
13:12	SM0_VSYNC_MOD E	Restrict SIF master 0 trigger within VSYNC pulse 00: Disable 01: Allow triggered in VSYNC pulse 10: Allow triggered at VSYNC rising edge
11:5	RESV2	
4	SM0_CS_STATUS	Clock stretching status 0: no clock stretching 1: clock stretching
3	SM0_SCL_STATE	SCL value on the bus
2	SM0_SDA_STATE	SDA value on the bus
1	SM0_EN	SIF master 0 enable bit 0: Disable SIF master 0. 1: Enable SIF master 0.
0	SM0_SCL_STRECH	Clock stretching enable 0: Not allow slaves hold SCL 1: Allow slaves hold SCL

10000944 SM0CTL1 Serial interface master 0 control 1 register 00000000

Bit	31	30	29	28	27	26	25	24	23	22	21	20	19	18	17	16
Name									SM0_ACK							
Type									RO							
Reset									0	0	0	0	0	0	0	0
Bit	15	14	13	12	11	10	9	8	7	6	5	4	3	2	1	0
Name					SM0_PGLEN				SM0_MODE				SM 0_T RI			
Type					RW				RW				RW			
Reset					0	0	0		0	0	0					0

Bit(s)	Name	Description
23:16	SM0_ACK	Acknowledge bits ACK[7:0] is acknowledge of 8 bytes of data
10:8	SM0_PGLEN	Page length Page length of sequential read/write. The maximum is 8 bytes. Set 0 as 1 byte.
6:4	SM0_MODE	SIF master mode 001: Start

Bit(s)	Name	Description
0	SM0_TRI	010: Write data 011: Stop 100: Read data with no ack for final byte 101: Read data with ack Trigger serial interface 0: Read back as serial interface is idle. 1: Set 1 to trigger this serial interface. Read back as serial interface is busy.

10000950 **SM0D0** **Serial interface master 0 data 0 register** **FFFFFF**
FF

Bit	31	30	29	28	27	26	25	24	23	22	21	20	19	18	17	16
Name	SM0_DATA3								SM0_DATA2							
Type	RW								RW							
Reset	x	x	x	x	x	x	x	x	x	x	x	x	x	x	x	x
Bit	15	14	13	12	11	10	9	8	7	6	5	4	3	2	1	0
Name	SM0_DATA1								SM0_DATA0							
Type	RW								RW							
Reset	x	x	x	x	x	x	x	x	x	x	x	x	x	x	x	x

Bit(s)	Name	Description
31:24	SM0_DATA3	Serial interface data byte 3
23:16	SM0_DATA2	Serial interface data byte 2
15:8	SM0_DATA1	Serial interface data byte 1
7:0	SM0_DATA0	Serial interface data byte 0

10000954 **SM0D1** **Serial interface master 0 data 1 register** **FFFFFF**
FF

Bit	31	30	29	28	27	26	25	24	23	22	21	20	19	18	17	16
Name	SM0_DATA7								SM0_DATA6							
Type	RW								RW							
Reset	x	x	x	x	x	x	x	x	x	x	x	x	x	x	x	x
Bit	15	14	13	12	11	10	9	8	7	6	5	4	3	2	1	0
Name	SM0_DATA5								SM0_DATA4							
Type	RW								RW							
Reset	x	x	x	x	x	x	x	x	x	x	x	x	x	x	x	x

Bit(s)	Name	Description
31:24	SM0_DATA7	Serial interface data byte 7
23:16	SM0_DATA6	Serial interface data byte 6
15:8	SM0_DATA5	Serial interface data byte 5
7:0	SM0_DATA4	Serial interface data byte 4

1000095C **PINTEN** **Peripheral interrupt enable register** **0000000**
0

Bit	31	30	29	28	27	26	25	24	23	22	21	20	19	18	17	16
Name																
Type																
Reset																
Bit	15	14	13	12	11	10	9	8	7	6	5	4	3	2	1	0
Name																SM0_INT_EN
Type																RW

Reset																	0
--------------	--	--	--	--	--	--	--	--	--	--	--	--	--	--	--	--	---

Bit(s)	Name	Description
0	SM0_INT_EN	Serial interface master 0 interrupt enable

10000960 **PINTST** Peripheral interrupt status register **0000000**
0

Bit	31	30	29	28	27	26	25	24	23	22	21	20	19	18	17	16
Name																
Type																
Reset																
Bit	15	14	13	12	11	10	9	8	7	6	5	4	3	2	1	0
Name																SM 0_I NT_ ST
Type																WS
Reset																0

Bit(s)	Name	Description
0	SM0_INT_ST	Serial interface master 0 interrupt status

10000964 **PINTCL** Peripheral interrupt clear register **0000000**
0

Bit	31	30	29	28	27	26	25	24	23	22	21	20	19	18	17	16
Name																
Type																
Reset																
Bit	15	14	13	12	11	10	9	8	7	6	5	4	3	2	1	0
Name																SM 0_I NT_ CL
Type																W1 C
Reset																0

Bit(s)	Name	Description
0	SM0_INT_CL	Serial interface master 0 interrupt clear

5.11 I2S Controller

5.11.1 Features

- I2S transmitter/receiver, which can be configured as master or slave.
- Supports 16-bit data, sampling rates of 8 kHz, 16 kHz, 22.05 kHz, 44.1 kHz, and 48 kHz
- Support stereo audio data transfer.
- 32-byte FIFO are available for data transmission.
- Supports GDMA access
- Supports 12 Mhz bit clock from external source (when in slave mode)

5.11.2 Block Diagram

The I²S transmitter block diagram is shown as below.

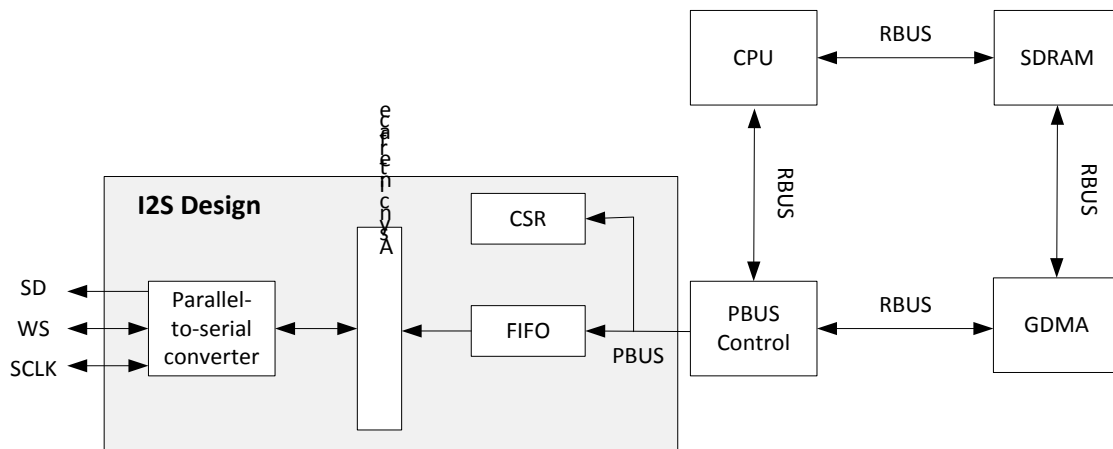

Figure 5-5 I²S Transmitter Block Diagram

The I²S interface consists of two separate cores, a transmitter and a receiver. Both can operate in either master or slave mode. The transmitter is only shown here in master or slave mode.

I²S Signal Timing For I²S Data Format

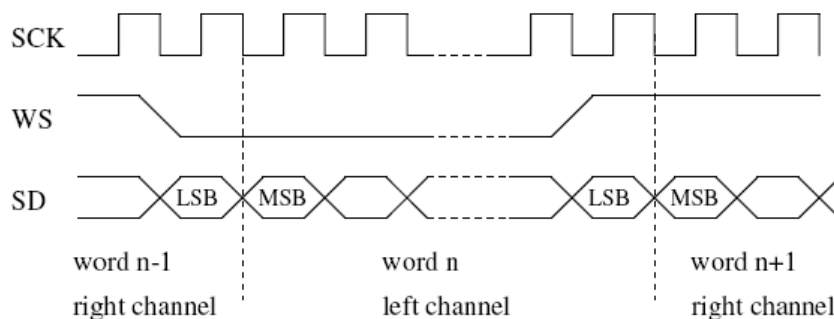

Figure 5-6 I2S Transmit/Receive

Serial data is transmitted in 2's complement with the MSB first. The transmitter always sends the MSB of the next word one clock period after the WS changes. Serial data sent by the transmitter may be synchronized with either the trailing (HIGH-to-LOW) or the leading (LOW-to-HIGH) edge of the clock signal. However, the serial data must be latched into the receiver on the leading edge of the serial clock signal, and so there are some restrictions when transmitting data that is synchronized with the leading edge.

The word select line indicates the channel being transmitted:

- WS = 0; channel 1 (left)
- WS = 1; channel 2 (right)

WS may change either on a trailing or leading edge of the serial clock, but it doesn't need to be symmetrical. In the slave, this signal is latched on the leading edge of the clock signal. The WS line changes one clock period before the MSB is transmitted. This allows the slave transmitter to derive synchronous timing of the serial data that will be set up for transmission. Furthermore, it enables the receiver to store the previous word and clear the input for the next Word.

5.11.3 Registers

I2S Changes LOG

Revision	Date	Author	Change Log
0.1	2014/1/12	Ken Wu	Initialization

Module name: I2S Base address: (+10000A00h)

Address	Name	Width	Register Function
10000A00	<u>I2S_CFG</u>	32	I2S Configuration I2S Tx/Rx Configuration Register
10000A04	<u>INT_STATUS</u>	32	Interrupt Status I2S Interrupt Status
10000A08	<u>INT_EN</u>	32	Interrupt Enable I2S Interrupt Enable Control Register
10000A0C	<u>FF_STATUS</u>	32	FIFO Status I2S Tx/Rx FIFO Status
10000A10	<u>TX_FIFO_WREG</u>	32	Transmit FIFO Write to Register Tx Write Data Buffer
10000A14	<u>RX_FIFO_RREG</u>	32	Receive FIFO Read Register DRAM PAD CONTROL 3
10000A18	<u>I2S_CFG1</u>	32	I2S Configuration 1 I2S Loopback Test Control Register
10000A20	<u>DIVCOMP_CFG</u>	32	Integer Part of the Divisor Register 1 Integer Part of the Divisor Register
10000A28	<u>DIVINT_CFG</u>	32	Integer Part of the Divisor Register 2 Integer Part of the Divisor Register

10000A00		<u>I2S_CFG</u>		I2S Configuration										00014040		
Bit	31	30	29	28	27	26	25	24	23	22	21	20	19	18	17	16
Name	I2S_EN	DM_A_EN	LIT_TIE_EN DIAN_DATA_FMT	SYSENDIAN				TX_EN				RX_EN		NO_RM_24BIT	DATA_24BIT	SLAVE_MODE
Type	RW	RW	RW	RW				RW				RW		RW	RW	RW

Reset	0	0	0	0				0				0		0	0	1
Bit	15	14	13	12	11	10	9	8	7	6	5	4	3	2	1	0
Name	RX_FF_THRES								TX_FF_THRES							
Type	RW								RW							
Reset	0	1	0	0					0	1	0	0				

Bit(s)	Name	Description
31	I2S_EN	I2S Enable Enables I2S. When disabled, all I2S control registers are cleared to their initial values. 0: Disable 1: Enable
30	DMA_EN	DMA Enable Enables DMA access. 0: Disable 1: Enable
29	LITTIE_ENDIAN_DATA_FMT	Little endian audio data 0: big endian audio data format 1: little endian audio data format
28	SYS_ENDIAN	System endian setting. 0: Little endian 1: Big endian
24	TX_EN	Transmitter on/off control 0: Disable 1: Enable
20	RX_EN	Receiver on/off control 0: Disable 1: Enable
18	NORM_24BIT	24-bit data format 0: compact data format 1: normal data format
17	DATA_24BIT	I2S data width 0: 16-bit data 1: 24-bit data
16	SLAVE_MODE	Sets master or slave mode. 0: Master: using internal clock 1: Slave: using external clock
15:12	RX_FF_THRES	Rx FIFO Threshold When the threshold is reached, the host/DMA is notified to fill FIFO. 2<RX_FF_THRES<6 (unit: word)
7:4	TX_FF_THRES	Tx FIFO Threshold When the threshold is reached, the host/DMA is notified to fill FIFO. 2<TX_FF_THRES<6 (unit: word)

1000A04 INT_STATUS Interrupt Status 0000000
0

Bit	31	30	29	28	27	26	25	24	23	22	21	20	19	18	17	16
Name																
Type																
Reset																
Bit	15	14	13	12	11	10	9	8	7	6	5	4	3	2	1	0
Name									RX_DM_A_FAULT	RX_OVRUN	RX_UNRUN	RX_THRES	TX_DM_A_FAULT	TX_OVRUN	TX_UNRUN	TX_THRES
Type									RW	RW	RW	RW	RW	RW	RW	RW
Reset									0	0	0	0	0	0	0	0

Bit(s)	Name	Description
7	RX_DMA_FAULT	Rx DMA Fault Detected Interrupt Asserts when a fault is detected in Rx DMA signals.
6	RX_OVRUN	Rx Overrun Interrupt Asserts when the Rx FIFO is overrun.
5	RX_UNRUN	Rx Underrun Interrupt Asserts when the Rx FIFO is underrun.
4	RX_THRES	Rx FIFO Below Threshold Interrupt Asserts when the Rx FIFO is lower than the defined threshold.
3	TX_DMA_FAULT	Tx DMA Fault Detected Interrupt Asserts when a fault is detected in Tx DMA signals.
2	TX_OVRUN	Tx FIFO Overrun Interrupt Asserts when the Tx FIFO is overrun.
1	TX_UNRUN	Tx FIFO Underrun Interrupt Asserts when the Tx FIFO is underrun.
0	TX_THRES	Tx FIFO Below Threshold Interrupt Asserts when the FIFO is lower than the defined threshold.

10000A08 INT_EN

Interrupt Enable

0000000
0

Bit	31	30	29	28	27	26	25	24	23	22	21	20	19	18	17	16
Name																
Type																
Reset																
Bit	15	14	13	12	11	10	9	8	7	6	5	4	3	2	1	0
Name									RX_INT3_EN	RX_INT2_EN	RX_INT1_EN	RX_INT0_EN	TX_INT3_EN	TX_INT2_EN	TX_INT1_EN	TX_INT0_EN
Type									RW	RW	RW	RW	RW	RW	RW	RW
Reset									0	0	0	0	0	0	0	0

Bit(s)	Name	Description
7	RX_INT3_EN	INT_STATUS[7] Enable Enables the Rx DMA Fault Detected Interrupt. This interrupt asserts when a fault is detected in Rx DMA signals.
6	RX_INT2_EN	INT_STATUS[6] Enable Enables the Rx Overrun Interrupt. This interrupt asserts when the Rx FIFO is overrun.
5	RX_INT1_EN	INT_STATUS[5] Enable Enables the Rx Underrun Interrupt. This interrupt asserts when the Rx FIFO is underrun.
4	RX_INT0_EN	INT_STATUS[4] Enable Enables the Rx FIFO Below Threshold Interrupt. This interrupt asserts when the Rx FIFO is lower than the defined threshold.
3	TX_INT3_EN	INT_STATUS[3] Enable Enables the Tx DMA Fault Detected Interrupt. This interrupt asserts when a fault is detected in Tx DMA signals.
2	TX_INT2_EN	INT_STATUS[2] Enable Enables the Tx FIFO Overrun Interrupt. This interrupt asserts when the Tx FIFO is overrun.
1	TX_INT1_EN	INT_STATUS[1] Enable Enables the Tx FIFO Underrun Interrupt. This interrupt asserts when the Tx FIFO is underrun.
0	TX_INT0_EN	INT_STATUS[0] Enable

Bit(s)	Name	Description
		Enables the Tx FIFO Below Threshold Interrupt. This interrupt asserts when the FIFO is lower than the defined threshold.

10000A0C FF_STATUS FIFO Status 0000001
0

Bit	31	30	29	28	27	26	25	24	23	22	21	20	19	18	17	16	
Name																	
Type																	
Reset																	
Bit	15	14	13	12	11	10	9	8	7	6	5	4	3	2	1	0	
Name				RX_AVCNT									TX_EPCNT				
Type				RO									RO				
Reset				0	0	0	0	0				1	0	0	0	0	

Bit(s)	Name	Description
12:8	RX_AVCNT	Rx FIFO Available Space Count Counts the available space for reads in Rx FIFO. (unit: word)
4:0	TX_EPCNT	Tx FIFO Available Space Count Counts the available space for writes in Tx FIFO. (unit: word)

10000A10 TX_FIFO_WR Transmit FIFO Write to Register 0000000
EG 0

Bit	31	30	29	28	27	26	25	24	23	22	21	20	19	18	17	16
Name	TX_FIFO_WDATA[31:16]															
Type	WO															
Reset	0	0	0	0	0	0	0	0	0	0	0	0	0	0	0	0
Bit	15	14	13	12	11	10	9	8	7	6	5	4	3	2	1	0
Name	TX_FIFO_WDATA[15:0]															
Type	WO															
Reset	0	0	0	0	0	0	0	0	0	0	0	0	0	0	0	0

Bit(s)	Name	Description
31:0	TX_FIFO_WDATA	Tx FIFO Write Data Buffer Buffers data to be written to the Tx FIFO.

10000A14 RX_FIFO_RR Receive FIFO Read Register 0000000
EG 0

Bit	31	30	29	28	27	26	25	24	23	22	21	20	19	18	17	16
Name	RX_FIFO_RDATA[31:16]															
Type	RO															
Reset	0	0	0	0	0	0	0	0	0	0	0	0	0	0	0	0
Bit	15	14	13	12	11	10	9	8	7	6	5	4	3	2	1	0
Name	RX_FIFO_RDATA[15:0]															
Type	RO															
Reset	0	0	0	0	0	0	0	0	0	0	0	0	0	0	0	0

Bit(s)	Name	Description
31:0	RX_FIFO_RDATA	Rx FIFO Read Data Buffer Buffers data read from the Rx FIFO.

10000A18 I2S_CFG1 I2S Configuration 1 0000000
0

Bit	31	30	29	28	27	26	25	24	23	22	21	20	19	18	17	16
Name	LB_K_E_N	EXT_LB_K_E_N														
Type	RW	RW														
Reset	0	0														
Bit	15	14	13	12	11	10	9	8	7	6	5	4	3	2	1	0
Name																I2S_FMT
Type																RW
Reset																0

Bit(s)	Name	Description
31	LBK_EN	Enables loopback mode. 0: Normal mode 1: Loopback mode ASYNC_TXFIFIO -> Tx -> Rx -> ASYNC_RXFIFIO
30	EXT_LBK_EN	Enables external loopback. 0: Normal mode 1: Enables external loop back. External A/D -> Rx -> Tx -> External D/A
0	I2S_FMT	I2S audio data format 0: i2s mode 1: left-justified mode

10000A20 DIVCOMP_CFG Integer Part of the Dividor Register 1 0000000
0

Bit	31	30	29	28	27	26	25	24	23	22	21	20	19	18	17	16
Name	CLK_EN															
Type	RW															
Reset	0															
Bit	15	14	13	12	11	10	9	8	7	6	5	4	3	2	1	0
Name								DIVCOMP								
Type								RW								
Reset								0	0	0	0	0	0	0	0	0

Bit(s)	Name	Description
31	CLK_EN	Enables setting of the I2S clock based on DIVCOMP and DIVINT parameters. 0: Disable 1: Enable
8:0	DIVCOMP	A parameter in an equation which determines FREQOUT. See DIVINT_CFG.

10000A28 DIVINT_CFG Integer Part of the Dividor Register 2 0000000
0

Bit	31	30	29	28	27	26	25	24	23	22	21	20	19	18	17	16
Name																
Type																
Reset																
Bit	15	14	13	12	11	10	9	8	7	6	5	4	3	2	1	0
Name								DIVINT								
Type								RW								

Reset							0	0	0	0	0	0	0	0	0	0
--------------	--	--	--	--	--	--	---	---	---	---	---	---	---	---	---	---

Bit(s)	Name	Description
9:0	DIVINT	<p>Integer Divider</p> <p>A parameter in an equation which determines FREQOUT: $FREQOUT = FREQIN * (1/2) * \{1 / [DIVINT + DIVCOMP / (512)]\}$ FREQIN is always fixed to 480 MHz.</p>

5.12 SPI Controller

5.12.1 Features

- Supports up to 2 SPI master operations
- Programmable clock polarity
- Programmable interface clock rate
- Programmable bit ordering
- Firmware-controlled SPI enable
- Programmable payload (address + data) length
- Supports 1/2/4 multi-IO SPI flash memory
- Supports command/user mode operation
- Supports SPI direct access
- Extends the addressable range from 24 bits to 32 bits for memory size larger than 128 Mb.

5.12.2 Block Diagram

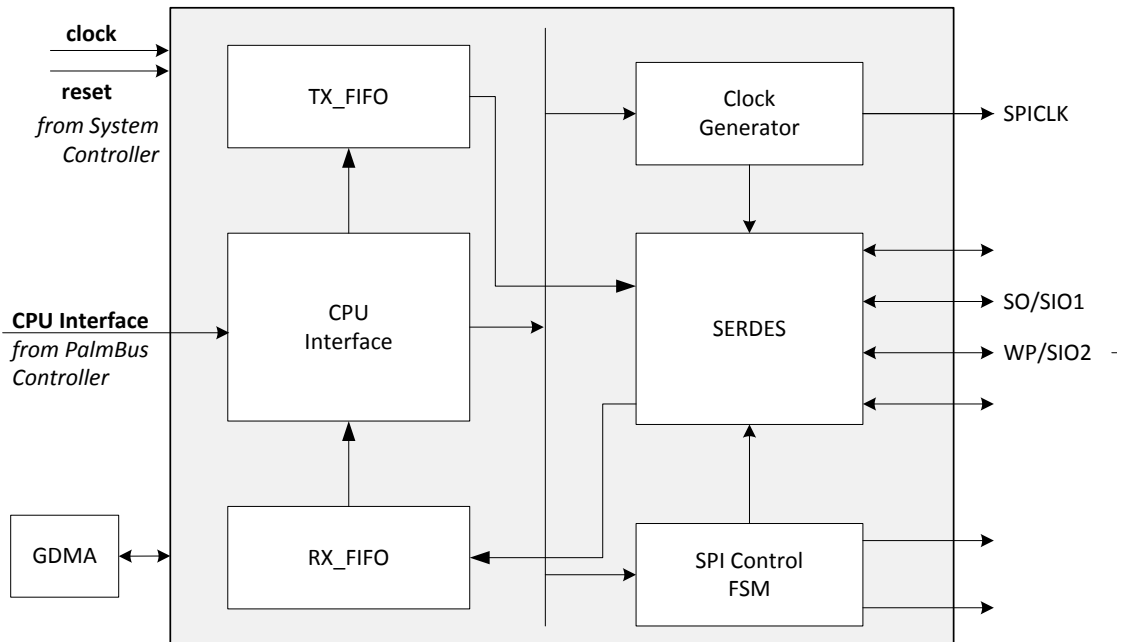

Figure 5-7 SPI Controller Block Diagram

5.12.3 Registers

SPI Changes LOG

Revision	Date	Author	Change Log
0.1	2012/8/29	Lancelot	Initialization
0.2	2012/11/6	Lancelot	1. Remove 0x38 SW_RST 2. Add CS_POLAR at 0x38
0.3	2012/11/23	Lancelot	Fix default value

Module name: SPI Base address: (+10000B00h)

Address	Name	Width	Register Function
10000B00	<u>SPI_TRANS</u>	32	SPI transaction control/status register
10000B04	<u>SPI_OP_ADDR</u>	32	SPI opcode/address register
10000B08	<u>SPI_DIDO_0</u>	32	SPI DI/DO data #0 register
10000B0C	<u>SPI_DIDO_1</u>	32	SPI DI/DO data #1 register
10000B10	<u>SPI_DIDO_2</u>	32	SPI DI/DO data #2 register
10000B14	<u>SPI_DIDO_3</u>	32	SPI DI/DO data #3 register
10000B18	<u>SPI_DIDO_4</u>	32	SPI DI/DO data #4 register
10000B1C	<u>SPI_DIDO_5</u>	32	SPI DI/DO data #5 register
10000B20	<u>SPI_DIDO_6</u>	32	SPI DI/DO data #6 register
10000B24	<u>SPI_DIDO_7</u>	32	SPI DI/DO data #7 register
10000B28	<u>SPI_MASTER</u>	32	SPI master mode register
10000B2C	<u>SPI_MORE_BUF</u>	32	SPI more buf control register
10000B30	<u>SPI_QUEUE_CTL</u>	32	SPI flash queue control register
10000B34	<u>SPI_STATUS</u>	32	SPI controller status register
10000B38	<u>SPI_CS_POLAR</u>	32	SPI chip select polarity
10000B3C	<u>SPI_SPACE</u>	32	SPI flash space control register

10000B00 **SPI_TRANS** **SPI transaction control/status register** **0016000**
1

Bit	31	30	29	28	27	26	25	24	23	22	21	20	19	18	17	16
Name	spi_addr_ext								Reserved0			spi_addr_size		Reserved1		spi_master_busy
Type	RW								RO			RW		RO		RO
Reset	0	0	0	0	0	0	0	0	0	0	0	1	0	1	1	0
Bit	15	14	13	12	11	10	9	8	7	6	5	4	3	2	1	0
Name	Reserved2							spi_master_start	miso_byte_cnt				mosi_byte_cnt			
Type	RO							WO	RW				RW			
Reset	0	0	0	0	0	0	0	0	0	0	0	0	0	0	0	1

Bit(s)	Name	Description
31:24	spi_addr_ext	SPI address extention Address extension for 32-bit SPI address size. Usually this field specifies the first byte of the address phase to transmit to SPI device when more_buf_mode = 0 and spi_addr_size = 3. And spi_addr[31:24], spi_addr[23:16], and spi_addr[15:0] are respectively the second, third and fourth byte of the address phase
20:19	spi_addr_size	SPI address size. 0: reserved. 1: spi_addr[15:0] of SPI DI data register are valid (16-bit size). 2: spi_addr[23:0] of SPI DI data register are valid (24-bit size). 3: {spi_addr_ext[7:0], spi_addr[23:0]} of SPI DI data register are valid (32-bit size) Note: The spi_addr_size is valid only when more_buf_mode = 0.
16	spi_master_busy	Transaction busy indication (Read-only). Writes to this bit are ignored. 0: No SPI transaction is ongoing. Software may start a new SPI transaction

Bit(s)	Name	Description
8	spi_master_start	<p>by writing to the SPI transaction start bit within this register. 1: An SPI transaction presently is underway. Software must not try to start a new SPI transaction. Software may not alter the value of any field of the SPI master control registers.</p> <p>SPI transaction start. Only writes to this field are meaningful, reads always return 0.</p> <p>Writes: 0: No effect 1: Starts SPI transaction.</p>
7:4	miso_byte_cnt	<p>SPI MISO (rx) byte count.</p> <p>Determines the number of bytes received from the SPI device from the SPI opcode/address register and the SPI DI/DO data #0 register. Values of 0 ~ 8 are valid, other values are illegal. Note: The miso_byte_cnt is valid only when more_buf_mode = 0.</p>
3:0	mosi_byte_cnt	<p>SPI MOSI (tx) byte count.</p> <p>Determines the number of bytes transmitted from the SPI opcode/address register and the SPI DI/DO data #0 register to the SPI device. Values of 1 ~ 8 are valid, other values are illegal. Note: The mosi_byte_cnt is valid only when more_buf_mode = 0. The transmitted data sequence is as follows: spi_opcode, spi_addr (conditional) and d0_byte ~ d3_byte (conditional).</p>

1000B04 SPI_OP_ADD **SPI opcode/address register** **0000000**
R **0**

Bit	31	30	29	28	27	26	25	24	23	22	21	20	19	18	17	16
Name	spi_addr[23:8]															
Type	RW															
Reset	0	0	0	0	0	0	0	0	0	0	0	0	0	0	0	0
Bit	15	14	13	12	11	10	9	8	7	6	5	4	3	2	1	0
Name	spi_addr[7:0]								spi_opcode							
Type	RW								RW							
Reset	0	0	0	0	0	0	0	0	0	0	0	0	0	0	0	0

Bit(s)	Name	Description
31:8	spi_addr	<p>SPI address. Usually this field specifies the 24-bits address to transmit to the SPI device when more_buf_mode = 0.</p> <p>1: (16-bits SPI address size), spi_addr[23:16] is the 1st byte of the address phase and spi_addr[15:8] is the 2nd byte of the address phase. 2: (24-bits SPI address size), spi_addr[31:24] is the 1st byte of the address phase and spi_addr[23:16] is the 2nd byte of the address phase and spi_addr[15:8] is the 3rd byte of the address phase. 3: (32-bits SPI address size), spi_addr[31:24] is the 2nd byte of the address phase and spi_addr[23:16] is the 3rd byte of the address phase and spi_addr[15:8] is the 4th byte of the address phase Note: For SPI read transaction and more_buf_mode = 0 Field [15:8] is also used to store the 6-th byte of data read phase. Field [23:16] is also used to store the 7-th byte of data read phase. Field [31:24] is also used to store the 8-th byte of data read phase.</p>
7:0	spi_opcode	<p>SPI opcode. Usually this field specifies the 8-bits opcode (instruction) to transmit to the SPI device as the first byte of a SPI transaction when more_buf_mode = 0.</p> <p>Note: For SPI read transaction and more_buf_mode = 0, this byte is also used to store the 5-th byte of data read phase according to the rx byte count miso_byte_cnt.</p>

1000B08 SPI_DIDO_0 **SPI DI/DO data #0 register** **0000000**
0

Bit	31	30	29	28	27	26	25	24	23	22	21	20	19	18	17	16
-----	----	----	----	----	----	----	----	----	----	----	----	----	----	----	----	----

Name	d3_byte								d2_byte							
Type	RW								RW							
Reset	0	0	0	0	0	0	0	0	0	0	0	0	0	0	0	0
Bit	15	14	13	12	11	10	9	8	7	6	5	4	3	2	1	0
Name	d1_byte								d0_byte							
Type	RW								RW							
Reset	0	0	0	0	0	0	0	0	0	0	0	0	0	0	0	0

Bit(s)	Name	Description
31:24	d3_byte	The 4th data byte of data read/write phase.
23:16	d2_byte	The 3th data byte of data read/write phase.
15:8	d1_byte	The 2nd data byte of data read/write phase.
7:0	d0_byte	The 1st data byte of data read/write phase.

1000B0C **SPI_DIDO_1** **SPI DI/DO data #1 register** **0000000**
0

Bit	31	30	29	28	27	26	25	24	23	22	21	20	19	18	17	16
Name	d3_byte								d2_byte							
Type	RW								RW							
Reset	0	0	0	0	0	0	0	0	0	0	0	0	0	0	0	0
Bit	15	14	13	12	11	10	9	8	7	6	5	4	3	2	1	0
Name	d1_byte								d0_byte							
Type	RW								RW							
Reset	0	0	0	0	0	0	0	0	0	0	0	0	0	0	0	0

Bit(s)	Name	Description
31:24	d3_byte	The 4th data byte of data read/write phase.
23:16	d2_byte	The 3th data byte of data read/write phase.
15:8	d1_byte	The 2nd data byte of data read/write phase.
7:0	d0_byte	The 1st data byte of data read/write phase.

1000B10 **SPI_DIDO_2** **SPI DI/DO data #2 register** **0000000**
0

Bit	31	30	29	28	27	26	25	24	23	22	21	20	19	18	17	16
Name	d3_byte								d2_byte							
Type	RW								RW							
Reset	0	0	0	0	0	0	0	0	0	0	0	0	0	0	0	0
Bit	15	14	13	12	11	10	9	8	7	6	5	4	3	2	1	0
Name	d1_byte								d0_byte							
Type	RW								RW							
Reset	0	0	0	0	0	0	0	0	0	0	0	0	0	0	0	0

Bit(s)	Name	Description
31:24	d3_byte	The 4th data byte of data read/write phase.
23:16	d2_byte	The 3th data byte of data read/write phase.
15:8	d1_byte	The 2nd data byte of data read/write phase.
7:0	d0_byte	The 1st data byte of data read/write phase.

1000B14 **SPI_DIDO_3** **SPI DI/DO data #3 register** **0000000**
0

Bit	31	30	29	28	27	26	25	24	23	22	21	20	19	18	17	16
Name	d3_byte								d2_byte							
Type	RW								RW							
Reset	0	0	0	0	0	0	0	0	0	0	0	0	0	0	0	0

Bit	15	14	13	12	11	10	9	8	7	6	5	4	3	2	1	0
Name	d1_byte								d0_byte							
Type	RW								RW							
Reset	0	0	0	0	0	0	0	0	0	0	0	0	0	0	0	0

Bit(s)	Name	Description
31:24	d3_byte	The 4th data byte of data read/write phase.
23:16	d2_byte	The 3th data byte of data read/write phase.
15:8	d1_byte	The 2nd data byte of data read/write phase.
7:0	d0_byte	The 1st data byte of data read/write phase.

1000B18 **SPI_DIDO_4** **SPI DI/DO data #4 register** **0000000**
0

Bit	31	30	29	28	27	26	25	24	23	22	21	20	19	18	17	16
Name	d3_byte								d2_byte							
Type	RW								RW							
Reset	0	0	0	0	0	0	0	0	0	0	0	0	0	0	0	0
Bit	15	14	13	12	11	10	9	8	7	6	5	4	3	2	1	0
Name	d1_byte								d0_byte							
Type	RW								RW							
Reset	0	0	0	0	0	0	0	0	0	0	0	0	0	0	0	0

Bit(s)	Name	Description
31:24	d3_byte	The 4th data byte of data read/write phase.
23:16	d2_byte	The 3th data byte of data read/write phase.
15:8	d1_byte	The 2nd data byte of data read/write phase.
7:0	d0_byte	The 1st data byte of data read/write phase.

1000B1C **SPI_DIDO_5** **SPI DI/DO data #5 register** **0000000**
0

Bit	31	30	29	28	27	26	25	24	23	22	21	20	19	18	17	16
Name	d3_byte								d2_byte							
Type	RW								RW							
Reset	0	0	0	0	0	0	0	0	0	0	0	0	0	0	0	0
Bit	15	14	13	12	11	10	9	8	7	6	5	4	3	2	1	0
Name	d1_byte								d0_byte							
Type	RW								RW							
Reset	0	0	0	0	0	0	0	0	0	0	0	0	0	0	0	0

Bit(s)	Name	Description
31:24	d3_byte	The 4th data byte of data read/write phase.
23:16	d2_byte	The 3th data byte of data read/write phase.
15:8	d1_byte	The 2nd data byte of data read/write phase.
7:0	d0_byte	The 1st data byte of data read/write phase.

1000B20 **SPI_DIDO_6** **SPI DI/DO data #6 register** **0000000**
0

Bit	31	30	29	28	27	26	25	24	23	22	21	20	19	18	17	16
Name	d3_byte								d2_byte							
Type	RW								RW							
Reset	0	0	0	0	0	0	0	0	0	0	0	0	0	0	0	0
Bit	15	14	13	12	11	10	9	8	7	6	5	4	3	2	1	0
Name	d1_byte								d0_byte							
Type	RW								RW							

Reset	0	0	0	0	0	0	0	0	0	0	0	0	0	0	0	0
--------------	---	---	---	---	---	---	---	---	---	---	---	---	---	---	---	---

Bit(s)	Name	Description
31:24	d3_byte	The 4th data byte of data read/write phase.
23:16	d2_byte	The 3th data byte of data read/write phase.
15:8	d1_byte	The 2nd data byte of data read/write phase.
7:0	d0_byte	The 1st data byte of data read/write phase.

10000B24 **SPI_DIDO_7** **SPI DI/DO data #7 register** **0000000**
0

Bit	31	30	29	28	27	26	25	24	23	22	21	20	19	18	17	16
Name	d3_byte								d2_byte							
Type	RW								RW							
Reset	0	0	0	0	0	0	0	0	0	0	0	0	0	0	0	0
Bit	15	14	13	12	11	10	9	8	7	6	5	4	3	2	1	0
Name	d1_byte								d0_byte							
Type	RW								RW							
Reset	0	0	0	0	0	0	0	0	0	0	0	0	0	0	0	0

Bit(s)	Name	Description
31:24	d3_byte	The 4th data byte of data read/write phase.
23:16	d2_byte	The 3th data byte of data read/write phase.
15:8	d1_byte	The 2nd data byte of data read/write phase.
7:0	d0_byte	The 1st data byte of data read/write phase.

10000B28 **SPI_MASTER** **SPI master mode register** **000D888**
0

Bit	31	30	29	28	27	26	25	24	23	22	21	20	19	18	17	16
Name	rs_slave_sel			clk_mode	rs_clk_sel											
Type	RW			RW	RW											
Reset	0	0	0	0	0	0	0	0	0	0	0	0	1	1	0	1
Bit	15	14	13	12	11	10	9	8	7	6	5	4	3	2	1	0
Name	cs_dsel_cnt				full_duplex	int_en	spi_start_sel	spi_prefch	bidi_rmode	cpha	cpol	lsb_fir	more_bufmode	serial_mode		
Type	RW				RW	RW	RW	RW	RW	RW	RW	RW	RW	RW		
Reset	1	0	0	0	1	0	0	0	1	0	0	0	0	0	0	0

Bit(s)	Name	Description
31:29	rs_slave_sel	select SPI device 0: select SPI device 0 (default is flash) 1: select SPI device 1 ... 7: select SPI device 7
28	clk_mode	This register is used to specify that period of SCLK HIGH is longer or period of SCLK LOW is longer when clock divisor(clk_sel) is odd. 0: period of SCLK LOW is longer. 1: period of SCLK HIGH is longer.
27:16	rs_clk_sel	Register Space SPI clock frequency select. 0: SPI clock frequency is hclk/2. (50% duty cycle, duty cycle is the ratio of the output high time to the total cycle time) 1: SPI clock frequency is hclk/3. (33.33% or 66.67% duty cycle) 2: SPI clock frequency is hclk/4. (50% duty cycle)

Bit(s)	Name	Description
		3: SPI clock frequency is hclk/5. (40% or 60% duty cycle) 4095: SPI clock frequency is hclk/4097.
15:11	cs_dsel_cnt	De-select time of SPI chip select is configured to occupy the number of cycles of AHB clock
10	full_duplex	Full duplex or half duplex mode. 0: half duplex mode. 1: full duplex mode. Full duplex timing diagram Note: The full_duplex is valid only when more_buf_mode = 1. The transmission is always as half duplex when more_buf_mode = 0;
9	int_en	Interrupt enable. 0: disable SPI interrupt. 1: enable SPI interrupt.
8	spi_start_sel	The interval between spi_cs_n and spi_sclk. 0: 3 clk 1: 6 clk
7	spi_prefetch	SPI pre-fetch buffer enable 0: disable pre-fetch buffer. 1: enable pre-fetch buffer.
6	bidir_mode	Bi-direction mode. In this mode, the SPI uses only one serial data pin for interface with external devices. The MOSI pin becomes the serial data I/O pin for the SPI transaction and MISO pin is not used. Bi-direction mode is used for the application with only 1 bi-direction serial pin for SPI transaction. 0: normal mode (both MOSI and MISO pins are used). 1: bi-direction mode (only MOSI pin is used). SPI host controller must operate in half duplex mode if bidir_mode = 1. Note: The bidir_mode is valid only when more_buf_mode = 1.
5	cpha	(CPHA, clock phase). Initial SPI clock phase for SPI transaction. There are four SPI modes used to latch data. These SPI modes latch data in one of four ways, and are defined by the logic state combinations of the CLK Polarity (CPOL) in relation to the CLK Phase (CPHA). The valid logic combinations identify and determine the SPI modes supported by the SPI device. SPI mode At CPOL=0 the base value of the clock is zero For CPHA=0 (mode 0), data is read on the clock's rising edge and data is changed on a falling edge. For CPHA=1 (mode 1), data is read on the clock's falling edge and data is changed on a rising edge. At CPOL=1 the base value of the clock is one (inversion of CPOL=0) For CPHA=0 (mode 2), data is read on clock's falling edge and data is changed on a rising edge. For CPHA=1 (mode 3), data is read on clock's rising edge and data is changed on a falling edge.
4	cpol	cpol (CPOL, clock polarity). Initial SPI clock polarity for SPI transaction.
3	lsb_first	0: MSB(most significant bit) is transferred first for SPI transaction. 1: LSB(least significant bit) is transferred first for SPI transaction.
2	more_buf_mode	Select 2 words buffer or 8 words buffer for SPI transaction. 0: SPI transfer data buffer size is only 2 words. In this mode, SPI DI/DO data #0 register and SPI opcode/address register are the data buffer for SPI transaction. And, SPI master follows mosi_byte_cnt and miso_byte_cnt to complete the transmission and reception, respectively. This kind of transaction must operate in half duplex mode. 1: SPI transfer data buffer size is 8 words. In this mode, SPI opcode/address register are the data buffer for SPI transaction and follows cmd_bit_cnt to complete the transaction. SPI DI/DO data #0~#7 register are the data buffer for SPI transaction and follows do_bit_cnt and di_bit_cnt to complete the transmission and reception, respectively. In half duplex mode, transmitted data are loaded from SPI opcode/address register and SPI DI/DO data #0~#7

Bit(s)	Name	Description
1:0	serial_mode	<p>registers. And, the received data will overwrite the SPI DI/DO data #0~#7 registers. In full duplex mode, SPI DI/DO data #0~#3 registers are used for transmission and SPI DI/DO #4~#7 registers are used for receipt.</p> <p>This mode is designed for Winbond SPI flash W25Q80/16/32 and W25X10/20/40/80/16/32/64 series.</p> <p>0: standard serial. 1: dual serial. 2: quad serial. 3: reserved.</p> <p>Note: The serial_mode is valid only when more_buf_mode = 0. The transaction mode is always as standard serial when more_buf_mode = 1.</p>

1000B2C SPI_MORE_B SPI more buf control register 0000000
UF 0

Bit	31	30	29	28	27	26	25	24	23	22	21	20	19	18	17	16
Name	Reserved0				cmd_bit_cnt				Reserved1				miso_bit_cnt[8:4]			
Type	RO				RW				RO				RW			
Reset	0	0	0	0	0	0	0	0	0	0	0	0	0	0	0	0
Bit	15	14	13	12	11	10	9	8	7	6	5	4	3	2	1	0
Name	miso_bit_cnt[3:0]				Reserved2				mosi_bit_cnt							
Type	RW				RO				RW							
Reset	0	0	0	0	0	0	0	0	0	0	0	0	0	0	0	0

Bit(s)	Name	Description
29:24	cmd_bit_cnt	<p>SPI command phase MOSI (tx) bit count. Determines the number of command bits transmitted from the SPI opcode/address register to the SPI device. Values of 0 ~ 32 are valid, but other values are illegal.</p> <p>Note: The cmd_bit_cnt is valid only when more_buf_mode = 1 and the SPI opcode/address register is treated as a command register.</p>
20:12	miso_bit_cnt	<p>SPI data phase MISO (rx) bit count. Determines the number of bits received from the SPI device into the SPI DI/DO data #0~#7 register. Values of 0 ~ 256 are valid, but other values are illegal. Maximum value is 256 for half duplex mode and 128 for full duplex mode. Please note that do_bit_cnt must be equal to di_bit_cnt in full duplex mode.</p> <p>Note: The miso_bit_cnt is valid only when more_buf_mode = 1.</p>
8:0	mosi_bit_cnt	<p>SPI data phase MOSI (tx) bit count. Determines the number of data bits transmitted from the SPI DI/DO data #0~#7 register to the SPI device. Values of 0 ~ 256 are valid, but other values are illegal. Maximum value is 256 for half duplex mode and 128 for full duplex mode.</p> <p>Note: The mosi_bit_cnt is valid only when more_buf_mode = 1.</p>

1000B30 SPI_QUEUE SPI flash queue control register 0000E4
CTL 0

Bit	31	30	29	28	27	26	25	24	23	22	21	20	19	18	17	16
Name	fs_page_sel				Reserved0[12:3]											
Type	RW				RO											
Reset	0	0	0	0	0	0	0	0	0	0	0	0	0	0	0	0
Bit	15	14	13	12	11	10	9	8	7	6	5	4	3	2	1	0
Name	Reserved0[2:0]			fs_busy	fs_addr_size_r	fs_addr_size	fs_di_ph_byc			Reserved1	fast_spi_sel					
Type	RO			RO	RO	RW	RW			RO	RW					
Reset	0	0	0	0	1	1	1	0	0	1	0	0	0	0	0	0

Bit(s)	Name	Description
31:26	fs_page_sel	<p>Flash Space Page Selection.</p> <p>0: (Page 0 space) 0x0000_0000 - 0x03ff_ffff 1: (Page 1 space) 0x0400_0000 - 0x07ff_ffff</p>

Bit(s)	Name	Description
12	fs_busy	<p>... 63: (Page 63 space) 0xffc0_0000 - 0xffff_ffff</p> <p>Transaction busy indication (Read-only) in flash space. Writes to this bit are ignored.</p> <p>0: No SPI flash space access is ongoing. Software may change the configuration related to flash space. 1: SPI flash space access presently is underway. Software may not alter the configuration related to flash space.</p>
11:10	fs_addr_size_r	<p>Latched fs_addr_size indication from internal spimc logic</p> <p>SPI address. This field specifies the 24-bits/16-bits address to transmit to the SPI device for SPI Flash Space Read operation only.</p> <p>0: 25-bit SPI address size 1: 16-bit SPI address size Reserved. 2: 24-bit SPI address size (default for 3B SPI flash) 3: 26-bit SPI address size (default for 4B SPI flash)</p> <p>If the change of the fs_addr_size is needed, the sequence below must be followed. Otherwise, the new fs_addr_size configuration will not be updated to the internal spimc logic .</p> <p>Step 1: Set new fs_addr_size. Step 2: Transmit mode change command (ex. En4B or Ex4B of MX25L25635E)</p> <p>Note: 1. The value fs_addr_size is not valid in Register Space. 2. The Spimc now only supports 3-Byte mode (24 bits) and 4-Byte mode (25 or 26 bits) switch.</p>
9:8	fs_addr_size	
7:4	fs_di_ph_byc	<p>Determines the number of data bytes transmitted from the SPI master controller to the SPI device for SPI Flash Space Read operation. This field is similar to mosi_byte_cnt in STCSR but is used for setting of flash space access control path.</p> <p>Note: this field should</p> <p>(if fs_addr_size_r = 2, 24-bit fs_addr_size) = 4 (OP + ADDR) if fast_spi_sel = 0 (0x03) = 5 (OP + ADDR + dummy) if fast_spi_sel = 1 (0x0b) = 5 (OP + ADDR + dummy) if fast_spi_sel = 2 (0x3b) = 5 (OP + ADDR + M7-0) if fast_spi_sel = 3 (0xbb) = 5 (OP + ADDR + dummy) if fast_spi_sel = 4 (0x6b) = 7 (OP + ADDR + M7-0 + dummy) if fast_spi_sel = 5 (0xeb) = 5 (OP + ADDR + M7-0) if fast_spi_sel = 6 (0xe3)</p> <p>(if fs_addr_size_r = 0 or 3, 25 or 26-bit fs_addr_size) = 5 (OP + ADDR) if fast_spi_sel = 0 (0x03) = 6 (OP + ADDR + dummy) if fast_spi_sel = 1 (0x0b) = 6 (OP + ADDR + dummy) if fast_spi_sel = 2 (0x3b) = 6 (OP + ADDR + M7-0) if fast_spi_sel = 3 (0xbb) = 6 (OP + ADDR + dummy) if fast_spi_sel = 4 (0x6b) = 8 (OP + ADDR + M7-0 + dummy) if fast_spi_sel = 5 (0xeb) = 6 (OP + ADDR + M7-0) if fast_spi_sel = 6 (0xe3)</p>
2:0	fast_spi_sel	<p>Select SPI flash read instruction for Flash Space</p> <p>0: standard read data instruction (0x03). 1: standard fast read data instruction (0x0b). 2: fast read dual output instruction defined in Winbond W25Qxx series SPI flash (0x03b). 3: fast read dual I/O instruction defined in Winbond W25Qxx series SPI flash (0xbb). 4: fast read quad output instruction defined in Winbond W25Qxx series SPI flash (0x6b). 5: fast read quad I/O instruction defined in Winbond W25Qxx series SPI flash (0xeb). 6: burst read quad I/O instruction defined in Winbond W25Qxx series SPI flash (0xe3).</p> <p>Note: serial_mode and more_buf_mode are don't care for this flash space access control path.</p>

10000B34 SPI_STATUS SPI controller status register 0000003
0

Bit	31	30	29	28	27	26	25	24	23	22	21	20	19	18	17	16
Name	Reserved0[25:10]															
Type	RO															
Reset	0	0	0	0	0	0	0	0	0	0	0	0	0	0	0	0
Bit	15	14	13	12	11	10	9	8	7	6	5	4	3	2	1	0
Name	Reserved0[9:0]										spi_flash_mode		Reserved1			spi_ok
Type	RO										RO		RO			RC
Reset	0	0	0	0	0	0	0	0	0	0	1	1	0	0	0	0

Bit(s)	Name	Description
5:4	spi_flash_mode	0: no SPI flash. 1: standard SPI flash. 2: specific SPI flash with dual interface capability. 3: specific SPI flash with quad interface capability.
0	spi_ok	When SPI transaction complete, SPI master controller will set this bit and assert SPI interrupt to notify software. Reading this register will clear this bit and de-assert SPI interrupt.

10000B38 SPI_CS_POL
AR SPI chip select polarity 0000000
0

Bit	31	30	29	28	27	26	25	24	23	22	21	20	19	18	17	16
Name																
Type																
Reset																
Bit	15	14	13	12	11	10	9	8	7	6	5	4	3	2	1	0
Name	cs_polar															
Type	RW															
Reset	0 0 0 0 0 0 0 0															

Bit(s)	Name	Description
7:0	cs_polar	Chip select default polarity set cs_polar[n]=1'b0 for cs[n] low active (SPI Flash) set cs_polar[n]=1'b1 for cs[n] high active

10000B3C SPI_SPACE SPI flash space control register 0000003
0

Bit	31	30	29	28	27	26	25	24	23	22	21	20	19	18	17	16
Name	Reserved[16:1]															
Type	RO															
Reset	0	0	0	0	0	0	0	0	0	0	0	0	0	0	0	0
Bit	15	14	13	12	11	10	9	8	7	6	5	4	3	2	1	0
Name	Res erv ed[0:0]	fs_slave_sel				fs_clk_sel										
Type	RO	RW				RW										
Reset	0	0	0	0	0	0	0	0	0	0	0	1	1	0	0	0

Bit(s)	Name	Description
14:12	fs_slave_sel	(Flash Space Slave Select) 0: select SPI device #0. (default is flash) 1: select SPI device #1. ... 7: select SPI device #7.
11:0	fs_clk_sel	Flash Space SPI clock frequency select.

Bit(s)	Name	Description
		0: SPI clock frequency is $hclk/2$. (50% duty cycle, duty cycle is the ratio of the output high time to the total cycle time)
		1: SPI clock frequency is $hclk/3$. (33.33% or 66.67% duty cycle)
		2: SPI clock frequency is $hclk/4$. (50% duty cycle)
		3: SPI clock frequency is $hclk/5$. (40% or 60% duty cycle)
		4095: SPI clock frequency is $hclk/4097$.

5.13 UART Lite
5.13.1 Features

- 2-pin UART
- 16550-compatible register set, except for Divisor Latch register
- 5-8 data bits
- 1-2 stop bits (1 or 2 stop bits are supported with 5 data bits)
- Even, odd, stick or no parity
- All standard baud rates up to 345600 b/s
- 16-byte receive buffer
- 16-byte transmit buffer
- Receive buffer threshold interrupt
- Transmit buffer threshold interrupt
- False start bit detection in asynchronous mode
- Internal diagnostic capabilities
- Break simulation
- Loop-back control for communications link fault isolation

5.13.2 Registers

n = 1; for uart1 only.

UARTn+0000h RX Buffer Register
UARTn_RBR

Bit	15	14	13	12	11	10	9	8	7	6	5	4	3	2	1	0
Name																
Type																

RBR RX Buffer Register. Read-only register. The received data can be read by accessing this register. Modified when LCR[7] = 0.

UARTn+0000h TX Holding Register
UARTn_THR

Bit	15	14	13	12	11	10	9	8	7	6	5	4	3	2	1	0
Name																
Type																

THR TX Holding Register. Write-only register. The data to be transmitted is written to this register, and then sent to the PC via serial communication. Modified when LCR[7] = 0.

UARTn+0004h Interrupt Enable Register
UARTn_IER

Bit	15	14	13	12	11	10	9	8	7	6	5	4	3	2	1	0
Name									CTSI	RTSI	XOFFI	X	EDSSI	ELSI	ETBEI	ERBFI
Type																
Reset																

IER By storing a '1' to a specific bit position, the interrupt associated with that bit is enabled. Otherwise, the interrupt is disabled.

IER[3:0] are modified when LCR[7] = 0.

IER[7:4] are modified when LCR[7] = 0 & EFR[4] = 1.

CTSI Masks an interrupt that is generated when a rising edge is detected on the CTS modem control line.

Note: This interrupt is only enabled when hardware flow control is enabled.

0 Unmask an interrupt that is generated when a rising edge is detected on the CTS modem control line.

1 Mask an interrupt that is generated when a rising edge is detected on the CTS modem control line.

RTSI Masks an interrupt that is generated when a rising edge is detected on the RTS modem control line.

Note: This interrupt is only enabled when hardware flow control is enabled.

- 0** Unmask an interrupt that is generated when a rising edge is detected on the RTS modem control line.
- 1** Mask an interrupt that is generated when a rising edge is detected on the RTS modem control line.

XOFFI Masks an interrupt that is generated when an XOFF character is received.

Note: This interrupt is only enabled when software flow control is enabled.

- 0** Unmask an interrupt that is generated when an XOFF character is received.
- 1** Mask an interrupt that is generated when an XOFF character is received.

EDSSI When set ("1"), an interrupt is generated if DDCD, TERI, DDSR or DCTS (MSR[4:1]) becomes set.

- 0** No interrupt is generated if DDCD, TERI, DDSR or DCTS (MSR[4:1]) becomes set.
- 1** An interrupt is generated if DDCD, TERI, DDSR or DCTS (MSR[4:1]) becomes set.

ELSI When set ("1"), an interrupt is generated if BI, FE, PE or OE (LSR[4:1]) becomes set.

- 0** No interrupt is generated if BI, FE, PE or OE (LSR[4:1]) becomes set.
- 1** An interrupt is generated if BI, FE, PE or OE (LSR[4:1]) becomes set.

ETBEI When set ("1"), an interrupt is generated if the TX Holding Register is empty or the contents of the TX FIFO

have been reduced to its Trigger Level.

- 0** No interrupt is generated if the TX Holding Register is empty or the contents of the TX FIFO have been reduced to its Trigger Level.
- 1** An interrupt is generated if the TX Holding Register is empty or the contents of the TX FIFO have been reduced to its Trigger Level

ERBFI When set ("1"), an interrupt is generated if the RX Buffer contains data.

- 0** No interrupt is generated if the RX Buffer contains data.
- 1** An interrupt is generated if the RX Buffer contains data.

UARTn+0008h Interrupt Identification Register

UARTn_IIR

Bit	15	14	13	12	11	10	9	8	7	6	5	4	3	2	1	0
Name									FIFOE		ID4	ID3	ID2	ID1	ID0	NINT
Type									RO							
Reset									0	0	0	0	0	0	0	1

IIR Identify if there are pending interrupts; ID4 and ID3 are presented only when EFR[4] = 1.

The following table gives the IIR[5:0] codes associated with the possible interrupts:

IIR[5:0]	Priority Level	Interrupt	Source
000001	-	No interrupt pending	
000110	1	Line Status Interrupt	BI, FE, PE or OE set in LSR
000100	2	RX Data Received	RX Data received or RX Trigger Level reached.
001100	2	RX Data Timeout	Timeout on character in RX FIFO.
000010	3	TX Holding Register Empty	TX Holding Register empty or TX FIFO Trigger Level reached.
000000	4	Modem Status change	DDCD, TERI, DDSR or DCTS set in MSR
010000	5	Software Flow Control	XOFF Character received
100000	6	Hardware Flow Control	CTS or RTS Rising Edge

Table 5-1 The IIR[5:0] codes associated with the possible interrupts

Line Status Interrupt: A RX Line Status Interrupt (IIR[5:0] == 000110b) is generated if ELSI (IER[2]) is set and any of BI, FE, PE or OE (LSR[4:1]) becomes set. The interrupt is cleared by reading the Line Status Register.

RX Data Received Interrupt: A RX Received interrupt (IER[5:0] == 000100b) is generated if EFRBI (IER[0]) is set and either RX Data is placed in the RX Buffer Register or the RX Trigger Level is reached. The interrupt is cleared by reading the RX Buffer Register or the RX FIFO (if enabled).

RX Data Timeout Interrupt:

When virtual FIFO mode is disabled, RX Data Timeout Interrupt is generated if all of the following apply:

1. FIFO contains at least one character;
2. The most recent character was received longer than four character periods ago (including all start, parity and stop bits);
3. The most recent CPU read of the FIFO was longer than four character periods ago.

The timeout timer is restarted on receipt of a new byte from the RX Shift Register, or on a CPU read from the RX FIFO.

The RX Data Timeout Interrupt is enabled by setting EFRBI (IER[0]) to 1, and is cleared by reading RX FIFO.

When virtual FIFO mode is enabled, RX Data Timeout Interrupt is generated if all of the following apply:

1. FIFO is empty;
2. The most recent character was received longer than four character periods ago (including all start, parity and stop bits);
3. The most recent CPU read of the FIFO was longer than four character periods ago.

The timeout timer is restarted on receipt of a new byte from the RX Shift Register.

RX Holding Register Empty Interrupt: A TX Holding Register Empty Interrupt (IIR[5:0] = 000010b) is generated if ETRBI (IER[1]) is set and either the TX Holding Register or, if FIFOs are enabled, the TX FIFO becomes empty.

The interrupt is cleared by writing to the TX Holding Register or TX FIFO if FIFO enabled.

Modem Status Change Interrupt: A Modem Status Change Interrupt (IIR[5:0] = 000000b) is generated if EDSSI (IER[3]) is set and either DDCCD, TERI, DDSR or DCTS (MSR[3:0]) becomes set. The interrupt is cleared by reading the Modem Status Register.

Software Flow Control Interrupt: A Software Flow Control Interrupt (IIR[5:0] = 010000b) is generated if Software Flow Control is enabled and XOFFI (IER[5]) becomes set, indicating that an XOFF character has been received. The interrupt is cleared by reading the Interrupt Identification Register.

Hardware Flow Control Interrupt: A Hardware Flow Control Interrupt (IER[5:0] = 100000b) is generated if Hardware Flow Control is enabled and either RTSI (IER[6]) or CTSI (IER[7]) becomes set indicating that a rising edge has been detected on either the RTS/CTS Modem Control line. The interrupt is cleared by reading the Interrupt Identification Register.

UARTn+0008h FIFO Control Register

UARTn_FCR

Bit	15	14	13	12	11	10	9	8	7	6	5	4	3	2	1	0
Name									RFTL1	RFTL0	TFTL1	TFTL0	DMA1	CLRT	CLRR	FIFOE
Type																WO

FCR FCR is used to control the trigger levels of the FIFOs, or flush the FIFOs.

FCR[7:6] is modified when LCR != BFh

FCR[5:4] is modified when LCR != BFh & EFR[4] = 1

FCR[4:0] is modified when LCR != BFh

FCR[7:6] RX FIFO trigger threshold

0 1

1 6

2 12

3 **RXTRIG**

FCR[5:4] TX FIFO trigger threshold

0 1

1 4

2 8

3 14 (FIFOSIZE - 2)

DMA1 This bit determines the DMA mode, which the TXRDY and RXRDY pins support. TXRDY and RXRDY act to support single-byte transfers between the UART and memory (DMA mode 0) or multiple byte transfers (DMA mode1). Note that this bit has no effect unless the FIFOE bit is set as well

0 The device operates in DMA Mode 0.

1 The device operates in DMA Mode 1.

TXRDY – mode0: Goes active (low) when the TX FIFO or the TX Holding Register is empty.

Becomes inactive when a byte is written to the Transmit channel.

TXRDY – mode1: Goes active (low) when there are no characters in the TX FIFO. Becomes inactive when the TX FIFO is full.

RXRDY – mode0: Becomes active (low) when at least one character is in the RX FIFO or the RX Buffer Register is full. Becomes inactive when there are no more characters in the RX FIFO or RX Buffer register.

RXRDY – mode1: Becomes active (low) when the RX FIFO Trigger Level is reached or an RX FIFO Character Timeout occurs. Goes inactive when the RX FIFO is empty.

CLRT Clear Transmit FIFO. This bit is self-clearing.

0 Leave TX FIFO intact.

1 Clear all the bytes in the TX FIFO.

CLRR Clear Receive FIFO. This bit is self-clearing.

0 Leave RX FIFO intact.

1 Clear all the bytes in the RX FIFO.

FIFOE FIFO Enabled. This bit must be set to 1 for any of the other bits in the registers to have any effect.

0 Disable both the RX and TX FIFOs.

1 Enable both the RX and TX FIFOs.

UARTn+000Ch Line Control Register

UARTn_LCR

Bit	15	14	13	12	11	10	9	8	7	6	5	4	3	2	1	0
Name									DLAB	SB	SP	EPS	PEN	STB	WLS1	WLS0
Type									R/W							
Reset									0	0	0	0	0	0	0	0

LCR Line Control Register. Determines characteristics of serial communication signals.

Modified when LCR[7] = 0.

DLAB Divisor Latch Access Bit.

0 The RX and TX Registers are read/written at Address 0 and the IER register is read/written at Address 4.

1 The Divisor Latch LS is read/written at Address 0 and the Divisor Latch MS is read/written at Address 4.

SB Set Break

0 No effect

1 SOUT signal is forced into the “0” state.

SP Stick Parity

0 No effect.

1 The Parity bit is forced into a defined state, depending on the states of EPS and PEN:

If EPS=1 & PEN=1, the Parity bit is set and checked = 0.

If EPS=0 & PEN=1, the Parity bit is set and checked = 1.

EPS Even Parity Select

0 When EPS=0, an odd number of ones is sent and checked.

- 1** When EPS=1, an even number of ones is sent and checked.
- PEN** Parity Enable
 - 0** The Parity is neither transmitted nor checked.
 - 1** The Parity is transmitted and checked.
- STB** Number of STOP bits
 - 0** One STOP bit is always added.
 - 1** Two STOP bits are added after each character is sent; unless the character length is 5 when 1 STOP bit is added.
- WLS1,0** Word Length Select.
 - 0** 5 bits
 - 1** 6 bits
 - 2** 7 bits
 - 3** 8 bits

UARTn+0010h Modem Control Register

UARTn_MCR

Bit	15	14	13	12	11	10	9	8	7	6	5	4	3	2	1	0
Name									XOFF STATUS		X	DCM_EN	OUT2	OUT1	RTS	DTR
Type	R/W															
Reset									0		0	0	0	0	0	0

MCR Modem Control Register. Control interface signals of the UART.
MCR[4:0] are modified when LCR[7] = 0,
MCR[7:6] are modified when LCR[7] = 0 & EFR[4] = 1.

XOFF Status This is a read-only bit.
0 When an XON character is received.
1 When an XOFF character is received.

DCM_EN UART DCM function enable bit
0 UART DCM is disabled.
1 UART DCM is enabled.

OUT2 Controls the state of the output NOUT2, even in loop mode.
0 NOUT2=1.
1 NOUT2=0.

OUT1 Controls the state of the output NOUT1, even in loop mode.
0 NOUT1=1.
1 NOUT1=0.

RTS Controls the state of the output NRTS, even in loop mode.
0 NRTS=1.
1 NRTS=0.

DTR Control the state of the output NDTR, even in loop mode.
0 NDTR=1.
1 NDTR=0.

UARTn+0014h Line Status Register

UARTn_LSR

Bit	15	14	13	12	11	10	9	8	7	6	5	4	3	2	1	0
Name									FIFOERR	TEMT	THRE	BI	FE	PE	OE	DR
Type	R/W															
Reset									0	1	1	0	0	0	0	0

LSR Line Status Register.

Modified when LCR[7] = 0.

FIFOERR RX FIFO Error Indicator.

- 0 No PE, FE, BI set in the RX FIFO.
- 1 Set to 1 when there is at least one PE, FE or BI in the RX FIFO.

TEMT TX Holding Register (or TX FIFO) and the TX Shift Register are empty.

- 0 Empty conditions below are not met.
- 1 If FIFOs are enabled, the bit is set whenever the TX FIFO and the TX Shift Register are empty. If FIFOs are disabled, the bit is set whenever TX Holding Register and TX Shift Register are empty.

THRE Indicates if there is room for TX Holding Register or TX FIFO is reduced to its Trigger Level.

- 0 **Reset whenever the contents of the TX FIFO are more than its Trigger Level (FIFOs are enabled), or whenever TX Holding Register is not empty(FIFOs are disabled).**
- 1 Set whenever the contents of the TX FIFO are reduced to its Trigger Level (FIFOs are enabled), or whenever TX Holding Register is empty and ready to accept new data (FIFOs are disabled).

BI Break Interrupt.

- 0 Reset by the CPU reading this register
- 1 If the FIFOs are disabled, this bit is set whenever the SIN is held in the 0 state for more than one transmission time (START bit + DATA bits + PARITY + STOP bits).
If the FIFOs are enabled, this error is associated with a corresponding character in the FIFO and is flagged when this byte is at the top of the FIFO. When a break occurs, only one zero character is loaded into the FIFO: the next character transfer is enabled when SIN goes into the marking state and receives the next valid start bit.

FE Framing Error.

- 0 Reset by the CPU reading this register
- 1 If the FIFOs are disabled, this bit is set if the received data did not have a valid STOP bit. If the FIFOs are enabled, the state of this bit is revealed when the byte it refers to is the next to be read.

PE Parity Error

- 0 Reset by the CPU reading this register
- 1 If the FIFOs are disabled, this bit is set if the received data did not have a valid parity bit. If the FIFOs are enabled, the state of this bit is revealed when the referred byte is the next to be read.

OE Overrun Error.

- 0 Reset by the CPU reading this register.
- 1 If the FIFOs are disabled, this bit is set if the RX Buffer was not read by the CPU before new data from the RX Shift Register overwrote the previous contents.
If the FIFOs are enabled, an overrun error occurs when the RX FIFO is full and the RX Shift Register becomes full. OE is set as soon as this happens. The character in the Shift Register is then overwritten, but not transferred to the FIFO.

DR Data Ready.

- 0 Cleared by the CPU reading the RX Buffer or by reading all the FIFO bytes.
- 1 Set by the RX Buffer becoming full or by a byte being transferred into the FIFO.

UARTn+0018h Modem Status Register

UARTn_MSR

Bit	15	14	13	12	11	10	9	8	7	6	5	4	3	2	1	0
Name									DCD	RI	DSR	CTS	DDCD	TERI	DDSR	DCTS
Type									R/W	R/W	R/W	R/W	R/W	R/W	R/W	R/W
Reset									Input	Input	Input	Input	0	0	0	0

Note: After a reset, D4-D7 are inputs. A modem status interrupt can be cleared by writing '0' or set by writing '1' to this register. D0-D3 can be written to.

Modified when LCR[7] = 0.

MSR Modem Status Register

DCD Data Carry Detect.

When Loop = "0", this value is the complement of the NDCD input signal.

When Loop = "1", this value is equal to the OUT2 bit in the Modem Control Register.

RI Ring Indicator.

When Loop = "0", this value is the complement of the NRI input signal.

When Loop = "1", this value is equal to the OUT1 bit in the Modem Control Register.

DSR Data Set Ready

When Loop = "0", this value is the complement of the NDSR input signal.

When Loop = "1", this value is equal to the DTR bit in the Modem Control Register.

CTS Clear To Send.

When Loop = "0", this value is the complement of the NCTS input signal.

When Loop = "1", this value is equal to the RTS bit in the Modem Control Register.

DDCD Delta Data Carry Detect.

0 The state of DCD has not changed since the Modem Status Register was last read

1 Set if the state of DCD has changed since the Modem Status Register was last read.

TERI Trailing Edge Ring Indicator

0 The NRI input does not change since this register was last read.

1 Set if the NRI input changes from "0" to "1" since this register was last read.

DDSR Delta Data Set Ready

0 Cleared if the state of DSR has not changed since this register was last read.

1 Set if the state of DSR has changed since this register was last read.

DCTS Delta Clear To Send

0 Cleared if the state of CTS has not changed since this register was last read.

1 Set if the state of CTS has changed since this register was last read.

UARTn+001Ch Scratch Register

UARTn_SCR

Bit	15	14	13	12	11	10	9	8	7	6	5	4	3	2	1	0
Name													SCR[7:0]			
Type													R/W			

A general purpose read/write register. After reset, its value is un-defined.

Modified when LCR[7] = 0.

UARTn+0000h Divisor Latch (LS)

UARTn_DLL

Bit	15	14	13	12	11	10	9	8	7	6	5	4	3	2	1	0
Name													DLL[7:0]			
Type													R/W			
Reset													1			

UARTn+0004h Divisor Latch (MS)

UARTn_DLM

Bit	15	14	13	12	11	10	9	8	7	6	5	4	3	2	1	0
Name													DLL[7:0]			
Type													R/W			
Reset													0			

Note: DLL & DLM can only be updated if DLAB is set ("1").. Note too that division by 1 generates a BAUD signal that is constantly high.

Modified when LCR[7] = 1.

The table below shows the divisor needed to generate a given baud rate from CLK inputs of 13, 26 MHz and 52 MHz. The effective clock enable generated is 16 x the required baud rate.

BAUD	13MHz	26MHz	52MHz
-------------	--------------	--------------	--------------

110	7386	14773	29545
300	2708	5417	10833
1200	677	1354	2708
2400	338	677	1354
4800	169	339	677
9600	85	169	339
19200	42	85	169
38400	21	42	85
57600	14	28	56
115200	6	14	28

Table 5-2 Divisor needed to generate a given baud rate

UARTn+0008h Enhanced Feature Register

UARTn_EFR

Bit	15	14	13	12	11	10	9	8	7	6	5	4	3	2	1	0
Name									AUTO CTS	AUTO RTS	D5	ENABLE -E	SW FLOW CONT[3:0]			
Type									R/W	R/W	R/W	R/W	R/W			
Reset									0	0	0	0	0			

*NOTE: Only when LCR=BF'h

Auto CTS Enables hardware transmission flow control

- 0 Disabled.
- 1 Enabled.

Auto RTS Enables hardware reception flow control

- 0 Disabled.
- 1 Enabled.

Enable-E Enable enhancement features.

- 0 Disabled.
- 1 Enabled.

CONT[3:0] Software flow control bits.

- 00xx** No TX Flow Control
- 10xx** Transmit XON1/XOFF1 as flow control bytes
- 01xx** Transmit XON2/XOFF2 as flow control bytes
- 11xx** Transmit XON1 & XON2 and XOFF1 & XOFF2 as flow control words
- xx00** No RX Flow Control
- xx10** Receive XON1/XOFF1 as flow control bytes
- xx01** Receive XON2/XOFF2 as flow control bytes
- xx11** Receive XON1 & XON2 and XOFF1 & XOFF2 as flow control words

UARTn+0010h XON1

UARTn_XON1

Bit	15	14	13	12	11	10	9	8	7	6	5	4	3	2	1	0
Name																XON1[7:0]
Type																R/W
Reset																0

UARTn+0014h XON2

UARTn_XON2

Bit	15	14	13	12	11	10	9	8	7	6	5	4	3	2	1	0
Name																XON2[7:0]
Type																R/W

Reset																	0
-------	--	--	--	--	--	--	--	--	--	--	--	--	--	--	--	--	---

UARTn+0018h XOFF1

UARTn_XOFF1

Bit	15	14	13	12	11	10	9	8	7	6	5	4	3	2	1	0	
Name																XOFF1[7:0]	
Type																R/W	
Reset																0	

UARTn+001Ch XOFF2

UARTn_XOFF2

Bit	15	14	13	12	11	10	9	8	7	6	5	4	3	2	1	0	
Name																XOFF2[7:0]	
Type																R/W	
Reset																0	

UARTn+0024h HIGH SPEED UART

UARTn_HIGHSPEED

Bit	15	14	13	12	11	10	9	8	7	6	5	4	3	2	1	0	
Name																SPEED [1:0]	
Type																R/W	
Reset																0	

SPEED UART sample counter base

- 0** based on 16*baud_pulse, baud_rate = system clock frequency/16/{DLH, DLL}
- 1** based on 8*baud_pulse, baud_rate = system clock frequency/8/{DLH, DLL}
- 2** based on 4*baud_pulse, baud_rate = system clock frequency/4/{DLH, DLL}
- 3** based on sample_count * baud_pulse, baud_rate = system clock frequency / sample_count

When HIGHSPEED=3, the value (A * B) means ({DLM, DLL} * SAMPLE_COUNT).

When the Baudrate is more than 115200, it will be more accurate if we set HIGHSPEED=3.

The table below shows the divisor needed to generate a given baud rate from CLK inputs of 13M Hz based on different HIGHSPEED value.

BAUD	HIGHSPEED = 0	HIGHSPEED = 1	HIGHSPEED = 2	HIGHSPEED = 3
110	7386	14773	29545	7386 * 16
300	2708	7386	14773	2708 * 16
1200	677	2708	7386	677 * 16
2400	338	677	2708	338 * 16
4800	169	338	677	169 * 16
9600	85	169	338	85 * 16
19200	42	85	169	9 * 75
38400	21	42	85	13 * 26
57600	14	21	42	8 * 28
115200	7	14	21	4 * 28
230400	*	7	14	2 * 28
460800	*	*	7	1 * 28
921600	*	*	*	1 * 14

Table 5-3 Divisor needed to generate a given baud rate from 13MHz based on different HIGHSPEED value

The table below shows the divisor needed to generate a given baud rate from CLK inputs of 26 MHz based on different HIGHSPEED value.

BAUD	HIGHSPEED = 0	HIGHSPEED = 1	HIGHSPEED = 2	HIGHSPEED = 3
110	14773	29545	59091	7386 * 32
300	5417	14773	29545	2708 * 32
1200	1354	5417	14773	677 * 32
2400	677	1354	5417	338 * 32
4800	339	677	1354	169 * 32
9600	169	339	667	85 * 32
19200	85	169	339	18 * 75
38400	42	85	169	26 * 26
57600	28	42	85	16 * 28
115200	14	28	42	8 * 28
230400	7	14	28	4 * 28
460800	*	7	14	2 * 28
921600	*	*	7	1 * 28

Table 5-4 Divisor needed to generate a given baud rate from 26 MHz based on different HIGHSPEED value

The table below shows the divisor needed to generate a given baud rate from CLK inputs of 52MHz based on different HIGHSPEED value.

BAUD	HIGHSPEED = 0	HIGHSPEED = 1	HIGHSPEED = 2	HIGHSPEED = 3
110	29545	59091	118182	14773 * 32
300	10833	29545	59091	5417 * 32
1200	2708	10833	29545	1354 * 32
2400	1354	2708	10833	667 * 32
4800	677	1354	2708	339 * 32
9600	339	677	1354	169 * 32
19200	169	339	677	36 * 75
38400	85	169	339	52 * 26
57600	56	85	169	32 * 28
115200	28	56	85	16 * 28
230400	14	28	56	8 * 28
460800	7	14	28	4 * 28
921600	*	7	14	2 * 28

Table 5-5 Divisor needed to generate a given baud rate from 52 MHz based on different HIGHSPEED value

UARTn+0028hSAMPLE_COUNT

UARTn_SAMPLE_COUNT

Bit	15	14	13	12	11	10	9	8	7	6	5	4	3	2	1	0
Name	SAMPLECOUNT [7:0]															
Type	R/W															
Reset	0															

When HIGHSPEED=3, the sample_count is the threshold value for UART sample counter (sample_num).

Count from 0 to sample_count.

UARTn+002Ch SAMPLE_POINT

UARTn_SAMPLE_POINT

Bit	15	14	13	12	11	10	9	8	7	6	5	4	3	2	1	0
Name	SAMPLEPOINT [7:0]															
Type	R/W															
Reset	Ffh															

When HIGHSPEED=3, UART gets the input data when sample_count=sample_num.

e.g. system clock = 13MHz, 921600 = 13000000 / 14

sample_count = 14 and sample point = 7 (sample the central point to decrease the inaccuracy)

The SAMPLE_POINT is usually (SAMPLE_COUNT/2).

UARTn+0034hRate Fix Address

UARTn_RATEFIX_AD

Bit	15	14	13	12	11	10	9	8	7	6	5	4	3	2	1	0
Name																RXTE_FIX
Type																R/W
Reset																0

rate_fix When you set "rate_fix"(34H[0]), you can transmit and receive data only if the input **f16m_en** is enable.

UARTn+003Ch Guard time added register

UARTn_GUARD

Bit	15	14	13	12	11	10	9	8	7	6	5	4	3	2	1	0
Name												GUARD_EN	GUARD_CNT[3:0]			
Type												R/W	R/W	R/W	R/W	R/W
Reset												0	0	0	0	0

GUARD_CNT Guard interval count value. Guard interval = (1/(system clock / div_step / div)) *

GUARD_CNT.

GUARD_EN Guard interval add enable signal.

0 No guard interval added.

1 Add guard interval after stop bit.

UARTn+0040h Escape character register

UARTn_ESCAPE_DAT

Bit	15	14	13	12	11	10	9	8	7	6	5	4	3	2	1	0
Name	ESCAPE_DAT[7:0]															
Type	WO															
Reset	FFh															

ESCAPE_DAT Escape character added before software flow control data and escape character, i.e. if tx data is xon (31h), with esc_en =1, uart transmits data as esc + CEh (~xon).

UARTn+0044h Escape enable register

UARTn_ESCAPE_EN

Bit	15	14	13	12	11	10	9	8	7	6	5	4	3	2	1	0
Name																ESC_EN
Type																R/W
Reset																0

ESC_EN Add escape character in transmitter and remove escape character in receiver by UART.

- 0 Do not deal with the escape character.
- 1 Add escape character in transmitter and remove escape character in receiver.

UARTn+0048h Sleep enable register

UARTn_SLEEP_EN

Bit	15	14	13	12	11	10	9	8	7	6	5	4	3	2	1	0
Name																SELLP_EN
Type																R/W
Reset																0

SLEEP_EN For sleep mode issue

- 0 Do not deal with sleep mode indicate signal
- 1 To activate hardware flow control or software control according to software initial setting when chip enters sleep mode. Releasing hardware flow when chip wakes up; but for software control, UART sends xon when awoken and when FIFO does not reach threshold level.

UARTn+004Ch Virtual FIFO enable register

UARTn_VFIFO_EN

Bit	15	14	13	12	11	10	9	8	7	6	5	4	3	2	1	0
Name																VFIFO_EN
Type																R/W
Reset																0

VFIFO_EN Virtual FIFO mechanism enable signal.

- 0 Disable VFIFO mode.
- 1 Enable VFIFO mode. When virtual mode is enabled, the flow control is based on the DMA threshold, and generates a timeout interrupt for DMA.

UARTn+0050h Rx Trigger Address

UARTn_RXTRI_AD

Bit	15	14	13	12	11	10	9	8	7	6	5	4	3	2	1	0
Name																RXTRIG[3:0]
Type																R/W
Reset																0

RXTRIG When {rtm,rtl}=2'b11, The Rx FIFO threshold will be Rxtrig.

UARTn+0054h Fractional Divider LSB Address

UARTn_FRACDIV_L

Bit	15	14	13	12	11	10	9	8	7	6	5	4	3	2	1	0
Name																FRACDIV_L
Type																R/W
Reset								0	0	0	0	0	0	0	0	0

FRACDIV_L Add sampling count (+1) from state data7 to state data0, in order to contribute fractional divisor.

UARTn+0058h Fractional Divider MSB Address

UARTn_FRACDIV_M

Bit	15	14	13	12	11	10	9	8	7	6	5	4	3	2	1	0
Name																FRACDIV_M
Type																R/W
Reset															0	0

FRACDIV_M Add sampling count in state stop and state parity, in order to contribute fractional divisor.

FRACDIV_L / FRACDIV_L Add one sampling period to each symbol, in order to increase the baud rate accuracy.

bit_extend register = FRACDIV_L[7:0]
FRACDIV_M[1:0]

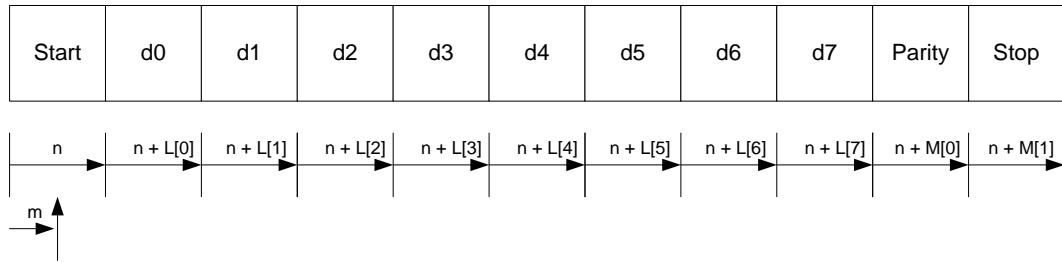

UARTn+005Ch FIFO Control Register

UARTn_FCR_RD

Bit	15	14	13	12	11	10	9	8	7	6	5	4	3	2	1	0
Name									RFTL1	RFTL0	TFTL1	TFTL0	DMA1			FIFOE
Type									RO							RO

Read out UARTn_FCR register.

UARTn+0060h TX Active Enable Address

UARTn_TX_ACTIVE_EN

Bit	15	14	13	12	11	10	9	8	7	6	5	4	3	2	1	0
Name															TX_PU_EN	TX_OE_EN
Type															R/W	R/W
Reset															0	0

TX_OE_EN Enable UART_TX_OE switching function. TX_OE is to control UART_TX output enable.

TX_PU_EN Enable UART_TX_PU switching function. TX_PU is to control UART_TX pull up enable.

5.14 PCM Controller

5.14.1 Features

- Two clock sources are reserved for PCM circuit. (From internal clock generator, INT_PCM_CLK and EXT_PCM_CLK)
- PCM module can drive a clock out (with fraction-N divisor) to an external codec.
- Up to 4 channels PCM are available. 4 to 128 slots are configurable.
- Each channel supports a-law (8-bit)/u-law (8-bit)/raw-PCM (8-bit and 16-bit) transfer.
- Hardware converter of a-law<->raw-16 and u-law <-> raw-16 are implemented in design.
- Support long (8 cycle)/short (1 cycle)/configurable (intervals are configurable, use to emulate I²S interface) FSYNC.
- DATA & FSYNC can be driven and sampled by either rising/falling of clock.
- Last bit of DTX can be configured as tri-stated on falling edge.
- Beginning of each slot is configurable by 10-bit registers on each channel.
- 32-byte FIFO are available for each channel
- PCM interface can emulate I2S interface (only 16-bit data-width supported).
- MSB/LSB order is configurable.
- Supports both a-law/u-law (8-bits) →linear PCM(16-bit) and linear PCM(16-bit) → a-law/u-law (8-bit)

5.14.2 Block Diagram

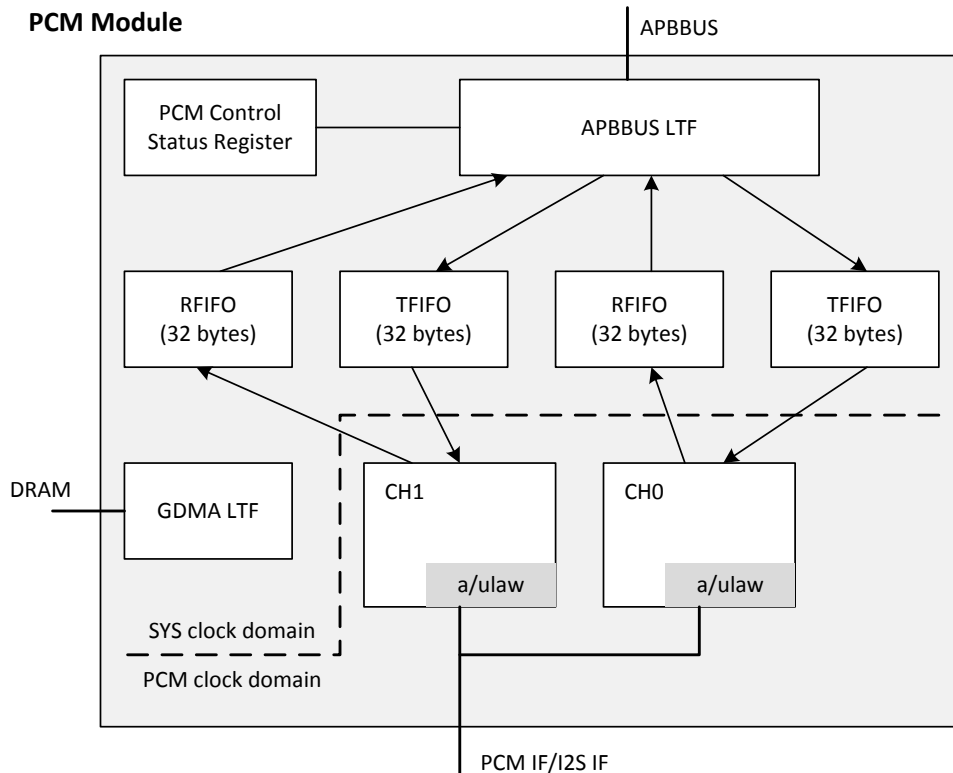

Figure 5-8 PCM Controller Block Diagram

Two clock domains are partitioned in this design. PCM converter (u-law <=> raw-16-bit and A-law <=> raw 16-bit) are implemented in PCM. The threshold of FIFO is configurable. When the threshold is reached, PCM (a) triggers the DMA interface to notify external DMA engine to transfer data, and (b) triggers an interrupt to the host.

The interrupt sources include:

- The threshold is reached.
- FIFO is under-run or over-run.
- A fault is detected at the DMA interface.

The A-law and u-law converter is implemented based on the ITU-G.711 A-law and u-law table. In this design, both A-law/u-law(8-bit) → linear PCM (16-bit) and linear PCM (16-bit) → A-law/u-law (8-bit) are supported.

The data-flow from codec to PCM-controller (Rx-flow) is shown as below:

- The PCM controller latches the data from DRX at the indicated time slot and then writes it to FIFO. If FIFO is full, the data is lost.
- When the Rx-FIFO reaches the threshold, two actions may be taken:
 - When DMA_ENA=1, DMA_REQ is asserted to request a burst transfer. It rechecks the FIFO threshold after DMA_END is asserted by GDMA. (GDMA should be configured before channel is enabled.)
 - Assert the interrupt source to notify the host. The host can check RFIFO_AVAIL information then get back the data from FIFO.

The data flow from the PCM controller to codec (Tx-flow) is shown below. After GDMA is configured, software should configure and enable the PCM channel. The empty FIFO should behave as follows.

- When DMA_ENA=1, DMA_REQ is triggered to request a burst transfer. It then re-checks the FIFO threshold after DMA_END is asserted by GDMA (a burst is completed).
- The Interrupt source is asserted to notify HOST. HOST writes the data to Tx-FIFO. After that, HOST rechecks TFIFO_EMPTY information, and then writes more data if available.

NOTE: When DMA_ENA=1, the burst size of GDMA should be less than the threshold value.

5.14.3 List of Registers

5.14.4 PCM Configuration

PCM Initialization Flow

1. Set PCM_CFG
2. Set CH0/1_CFG
3. Write PCM data to FIFO CH0/1_FIFO
4. Set GLB_CFG to enable the PCM and channel.
5. Set divisor clock
6. Enable clock
7. Monitor FF_STATUS to receive/transmit the other PCM data.

PCM Configuration Examples

Below are some examples of PCM configuration.

Case 1:

CFG_FSYNC Register: CFG_FSYNC_EN = 0 (PS: fsync is always driven at SLOT_CNT=1)

CH0_CFG Register: TS_START=1

CH1_CFG Register: TS_START=9

PCM_CFG Register: LONG_FSYNC=1'b0, FSYNC_POL=1'b1, DRX_TRI=1'b0, SLOT_MODE=3'b0

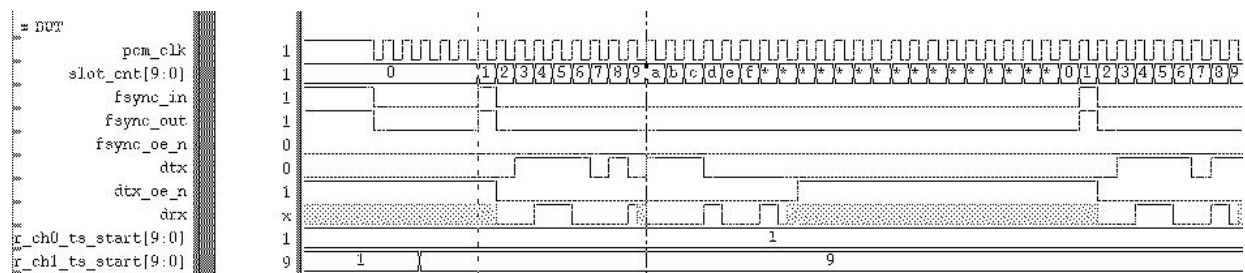

Case 2:

CFG_FSYNC Register: CFG_FSYNC_EN = 1, START_LOC=0, interval=16
 CH0_CFG Register: TS_START=1
 CH1_CFG Register: TS_START=17
 PCM_CFG Register: LONG_FSYNC=1'b0, FSYNC_POL=1'b1, DRX_TRI=1'b0, SLOT_MODE=3'b0, RAW16-bits

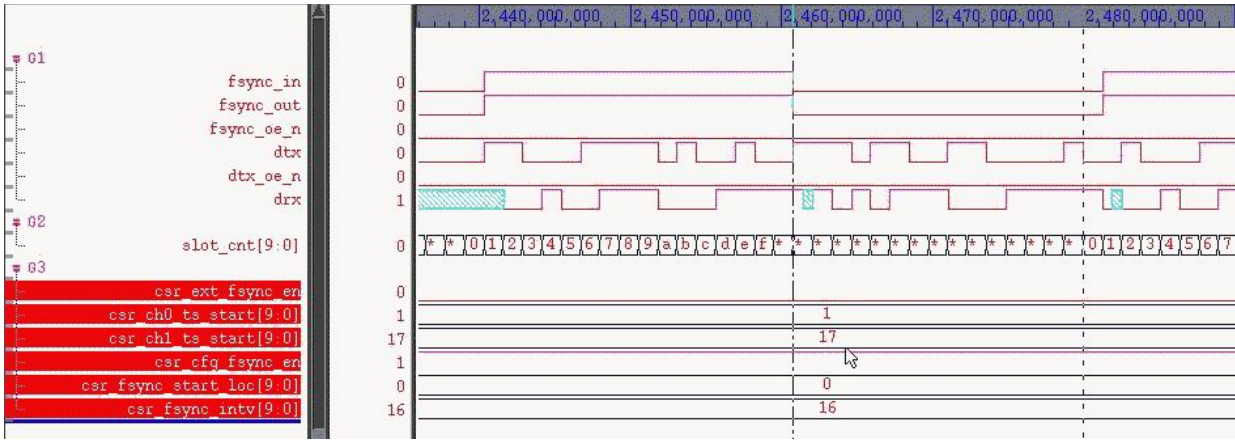

Case 3:
 CFG_FSYNC Register: CFG_FSYNC_EN = 1, START_LOC=0x1A, interval=2
 CH0_CFG Register: TS_START=1 (disable)
 CH1_CFG Register: TS_START=0x1A
 PCM_CFG Register: LONG_FSYNC=1'b0, FSYNC_POL=1'b0 (LOW active), DRX_TRI=1'b0, SLOT_MODE=3'b0, RAW16-bits

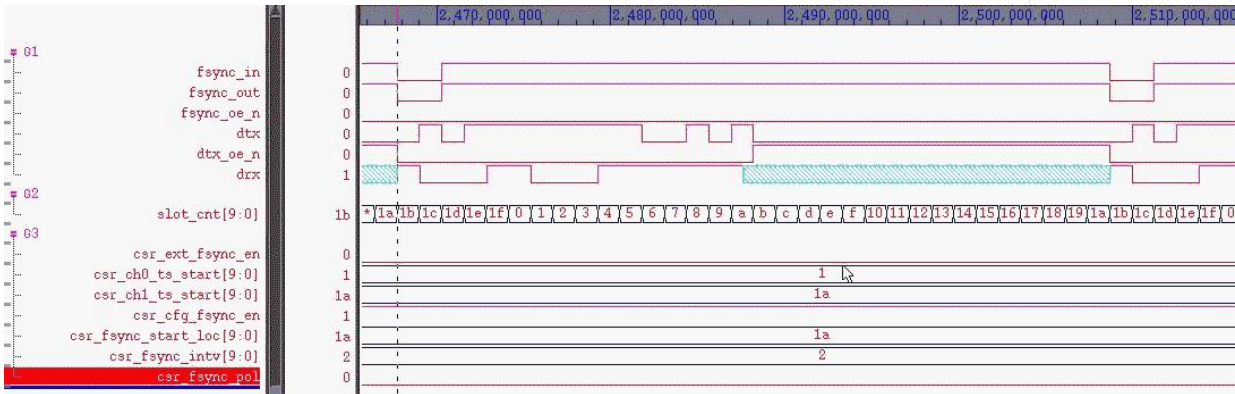

5.14.5 Register

PCM Changes LOG

Revision	Date	Author	Change Log
0.1	2012/10/8	Paddy Wu	Initialization

Module name: PCM Base address: (+10002000h)

Address	Name	Width	Register Function
10002000	<u>GLB_CFG</u>	32	Global Config
10002004	<u>PCM_CFG</u>	32	PCM configuration
10002008	<u>INT_STATUS</u>	32	Interrupt status
1000200C	<u>INT_EN</u>	32	Interrupt enable

10002010	<u>CHA0_FF_STA TUS</u>	32	Channel A0(represents channel 0) FIFO status
10002014	<u>CHB0_FF_STA TUS</u>	32	Channel B0(represents channel 1) FIFO status
10002020	<u>CHA0_CFG</u>	32	Channel A0(represents channel 0) Config
10002024	<u>CHB0_CFG</u>	32	Channel B0(represents channel 1) Config
10002030	<u>FSYNC_CFG</u>	32	FSYNC config
10002034	<u>CHA0_CFG2</u>	32	Channel A0(represents channel 0) Config
10002038	<u>CHB0_CFG2</u>	32	Channel B0(represents channel 1) Config
10002040	<u>IP_INFO</u>	32	IP version info
10002044	<u>RSV_REG16</u>	32	SPARE REG 16 bits
10002050	<u>DIVCOMP_CFG</u>	32	Dividor Compensation part config
10002054	<u>DIVINT_CFG</u>	32	Dividor Integer part config
10002060	<u>DIGDELAY CF G</u>	32	Digital delay config
10002080	<u>CH0_FIFO</u>	32	Channel 0 FIFO access point
10002084	<u>CH1_FIFO</u>	32	Channel 1 FIFO access point
10002088	<u>CH2_FIFO</u>	32	Channel 2 FIFO access point
1000208C	<u>CH3_FIFO</u>	32	Channel 3 FIFO access point
10002110	<u>CHA1_FF_STA TUS</u>	32	Channel A1(represents channel 3) FIFO status
10002114	<u>CHB1_FF_STA TUS</u>	32	Channel B1(represents channel 4) FIFO status
10002120	<u>CHA1_CFG</u>	32	Channel A1(represents channel 3) Config
10002124	<u>CHB1_CFG</u>	32	Channel B1(represents channel 1) Config
10002134	<u>CHA1_CFG2</u>	32	Channel A1(represents channel 3) Config
10002138	<u>CHB1_CFG2</u>	32	Channel B1(represents channel 4) Config

10002000 GLB_CFG Global Config

0044000
0

Bit	31	30	29	28	27	26	25	24	23	22	21	20	19	18	17	16
Name	PCM_EN	DMA_EN	LBK_EN	EXT_LBK_EN	RSV0					RFF_THRES			RSV1	TFF_THRES		
Type	RW	RW	RW	RW	RO					RW			RO	RW		
Reset	0	0	0	0	0	0	0	0	0	1	0	0	0	1	0	0
Bit	15	14	13	12	11	10	9	8	7	6	5	4	3	2	1	0
Name	RSV2												CH_EN			
Type	RO												RW			
Reset	0	0	0	0	0	0	0	0	0	0	0	0	0	0	0	0

Bit(s)	Name	Description
31	PCM_EN	PCM Enable When disabled, all FSM of PCM are cleared to their default value. 0: disable 1: enable
30	DMA_EN	DMA Enable 0: Disable the DMA interface, transfer data using software. 1: Enable the DMA interface, transfer data using DMA. 0: disable 1: enable
29	LBK_EN	loopback enable, loopback path is shown as (Asyn-TXFIFO ->DTX ->DRX->Asyn-RXFIFO) 0: disable 1: enable
28	EXT_LBK_EN	loopback enable, loopback path is shown as (Ext-Codect->DRX->DTX-

Bit(s)	Name	Description
		>Ext-Codec) 0: disable 1: enable
27:23	RSV0	Reserved
22:20	RFF_THRES	RXFIFO Threshold When the threshold is reached, the host/DMA is notified to fill FIFO. The threshold should be >2 and <6. When data in FIFO is under the threshold, the following interrupts and GDMA are triggered. CH0T_THRES, CH0R_THRES, CH1T_THRES, CH1R_THRES (unit: word)
19	RSV1	Reserved
18:16	TFF_THRES	TXFIFO Threshold When the threshold is reached, the host/DMA is notified to fill FIFO. It should be >2 and <6. When data in FIFO is over the threshold, an interrupt and DMA are triggered. (unit: word)
15:4	RSV2	Reserved
3:0	CH_EN	Channels 3 to 0 Tx and Rx Enable 0: disable 1: enable

10002004 PCM_CFG PCM configuration 0300000

Bit	31	30	29	28	27	26	25	24	23	22	21	20	19	18	17	16
Name	RSV0	CLKOUT_EN	RSV1		EXT_FSYNC	LONG_SYNC	FSYNC_POL	DTX_TRI	RSV2[20:13]							
Type	RO	RW	RO		RW	RW	RW	RW	RO							
Reset	0	0	0	0	0	0	1	1	0	0	0	0	0	0	0	0
Bit	15	14	13	12	11	10	9	8	7	6	5	4	3	2	1	0
Name	RSV2[12:0]												SLOT_MODE			
Type	RO												RW			
Reset	0	0	0	0	0	0	0	0	0	0	0	0	0	0	0	0

Bit(s)	Name	Description
31	RSV0	Reserved
30	CLKOUT_EN	PCM Clock Out Enable 0: A PCM clock is provided from the external Codec/OSC. 1: A PCM clock is provided from the internal divider. NOTE: Normally, the register should be asserted to 1. Also, it should be asserted after configuring the divider and enabling the divider clock. 0: EXT_CLK 1: INT_DIV
29:28	RSV1	Reserved
27	EXT_FSYNC	FSYNC is provided externally 0: FSYNC is generated by internal circuit. 1: FSYNC is provided externally
26	LONG_SYNC	FSYNC Mode 0: Short FSYNC 1: Long FSYNC
25	FSYNC_POL	FSYNC Polarity 0: FSYNC is low active 1: FSYNC is high active
24	DTX_TRI	DTX Tri-State Tristates DTX when the clock signal on the last bit is has a falling edge. 0: Non- tristate DTX

Bit(s)	Name	Description
		1: Tristate DTX
23:3	RSV2	Reserved
2:0	SLOT_MODE	Sets the number of slots in each PCM frame. 0: 4 slots, PCM clock out/in should be 256 KHz. 1: 8 slots, PCM clock out/in should be 512 KHz. 2: 16 slots, PCM clock out/in should be 1.024 MHz. 3: 32 slots, PCM clock out/in should be 2.048 MHz. 4: 64 slots, PCM clock out/in should be 4.096 MHz. 5: 128 slots, PCM clock out/in should be 8.192 MHz. Other: Reserved. NOTE: When using the external clock, the frequency clock should be equal to PCM_clock out. Otherwise, the PCM_CLKin should be 8.192 MHz. 0: _4_SLOT 1: _8_SLOT 2: _16_SLOT 3: _32_SLOT 4: _64_SLOT 5: _128_SLOT

10002008 INT_STATUS Interrupt status **0000000**
0

Bit	31	30	29	28	27	26	25	24	23	22	21	20	19	18	17	16
Name	RSV0[23:8]															
Type	RO															
Reset	0	0	0	0	0	0	0	0	0	0	0	0	0	0	0	0
Bit	15	14	13	12	11	10	9	8	7	6	5	4	3	2	1	0
Name	RSV0[7:0]								CH T_D MA _FA ULT	CH T_O VR UN	CH T_U NR UN	CH T_T HR ES	CH R_ DM A_F AU LT	CH R_ OV RU N	CH R_ UN RU N	CH R_T HR ES
Type	RO								W1 C	W1 C	W1 C	W1 C	W1 C	W1 C	W1 C	W1 C
Reset	0	0	0	0	0	0	0	0	0	0	0	0	0	0	0	0

Bit(s)	Name	Description
31:8	RSV0	Reserved
7	CHT_DMA_FAULT	Channel Tx DMA Fault Interrupt, Asserts when a fault has been detected in a CH-Tx DMA signal.
6	CHT_OVRUN	Channel Tx FIFO Overrun Interrupt, Asserts when the CH-Tx FIFO is overrun.
5	CHT_UNRUN	Channel Tx FIFO Underrun Interrupt, Asserts when the CH-Tx FIFO is underrun.
4	CHT_THRES	Channel Tx Threshold Interrupt, Asserts when the CH-Tx FIFO is lower than the defined threshold.
3	CHR_DMA_FAULT	Channel Rx DMA Fault Interrupt, Asserts when a fault is detected in a CH-Rx DMA signal.
2	CHR_OVRUN	Channel Rx Overrun Interrupt, Asserts when the CH-Rx FIFO is overrun.
1	CHR_UNRUN	Channel Rx Underrun Interrupt, Asserts when the CH-Rx FIFO is underrun.
0	CHR_THRES	Channel Rx Threshold Interrupt, Asserts when the CH-Rx FIFO is lower than the defined threshold.

1000200C INT_EN Interrupt enable **0000000**
0

Bit	31	30	29	28	27	26	25	24	23	22	21	20	19	18	17	16
-----	----	----	----	----	----	----	----	----	----	----	----	----	----	----	----	----

Name	RSV0[23:8]															
Type	RO															
Reset	0	0	0	0	0	0	0	0	0	0	0	0	0	0	0	0
Bit	15	14	13	12	11	10	9	8	7	6	5	4	3	2	1	0
Name	RSV0[7:0]								INT7_EN	INT6_EN	INT5_EN	INT4_EN	INT3_EN	INT2_EN	INT1_EN	INT0_EN
Type	RO								RW	RW	RW	RW	RW	RW	RW	RW
Reset	0	0	0	0	0	0	0	0	0	0	0	0	0	0	0	0

Bit(s)	Name	Description
31:8	RSV0	Reserved
7	INT7_EN	INT_STATUS[7] Enable, Enables the Channel Tx DMA Fault Interrupt. This interrupt asserts when a fault has been detected in a CH-Tx DMA signal.
6	INT6_EN	INT_STATUS[6] Enable, Enables the Channel Tx FIFO Overrun Interrupt. This interrupt asserts when the CH-Tx FIFO is overrun.
5	INT5_EN	INT_STATUS[5] Enable, Enables the Channel Tx FIFO Underrun Interrupt. This interrupt asserts when the CH-Tx FIFO is underrun.
4	INT4_EN	INT_STATUS[4] Enable, Enables the Channel Tx Threshold Interrupt. This interrupt when the CH-Tx FIFO is lower than the defined threshold.
3	INT3_EN	INT_STATUS[3] Enable, Enables the Channel Rx DMA Fault Interrupt. This interrupt when a fault is detected in a CH-Rx DMA signal.
2	INT2_EN	INT_STATUS[2] Enable, Enables the Channel Rx Overrun Interrupt. This interrupt when the CH-Rx FIFO is overrun.
1	INT1_EN	INT_STATUS[1] Enable, Enables the Channel Rx Underrun Interrupt. This interrupt when the CH-Rx FIFO is under-run.
0	INT0_EN	INT_STATUS[0] Enable, Enables the Channel Rx Threshold Interrupt. This interrupt asserts when the CH-Rx FIFO is lower than the defined threshold.

10002010 CHA0_FF_STA Channel A0(represents channel 0) FIFO status 00100008

Bit	31	30	29	28	27	26	25	24	23	22	21	20	19	18	17	16
Name	RSV0								CHTX_DMA_FAULT	CHTX_OVRUN	CHTX_UNRUN	CHTX_THRES	CHRX_DMA_FAULT	CHRX_OVRUN	CHRX_UNRUN	CHRX_THRES
Type	RO								W1C	W1C	W1C	W1C	W1C	W1C	W1C	W1C
Reset	0	0	0	0	0	0	0	0	0	0	0	1	0	0	0	0
Bit	15	14	13	12	11	10	9	8	7	6	5	4	3	2	1	0
Name	RSV1								CHRRFF_AVCNT				CHTRFF_EPCNT			
Type	RO								RO				RO			
Reset	0	0	0	0	0	0	0	0	0	0	0	0	1	0	0	0

Bit(s)	Name	Description
31:24	RSV0	Reserved
23	CHTX_DMA_FAULT	Tx DMA Fault Detected Interrupt, Asserts when a fault is detected in a Channel A0 Tx DMA signal.
22	CHTX_OVRUN	Tx Overrun Interrupt, Asserts when the Channel A0 Tx FIFO is overrun.
21	CHTX_UNRUN	Tx FIFO Underrun Interrupt, Asserts when the Channel A0 Tx FIFO is underrun.
20	CHTX_THRES	Tx FIFO Below Threshold Interrupt, Asserts when the Channel A0 FIFO is lower than the defined threshold.
19	CHRX_DMA_FAULT	Rx DMA Fault Detected Interrupt, Asserts when a fault is detected in a Channel A0 Rx DMA signal.

Bit(s)	Name	Description
18	CHRX_OVRUN	Rx FIFO Overrun Interrupt, Asserts when the Channel A0 Rx FIFO is overrun.
17	CHRX_UNRUN	Rx FIFO Underrun Interrupt, Asserts when the Channel A0 Rx FIFO is underrun.
16	CHRX_THRES	Rx FIFO Below Threshold Interrupt, Asserts when the Channel A0 FIFO is lower than the defined threshold.
15:8	RSV1	Reserved
7:4	CHRFF_AVCNT	Channel A0 RXFIFO Available Space Count, Counts the available space for reads in channel A0 RXFIFO.(unit: word)
3:0	CHTFF_EPCNT	Channel A0 TXFIFO Available Space Count, Counts the available space for writes in channel A0 TXFIFO.(unit: word)

10002014 CHB0_FF_ST Channel B0(represents channel 1) FIFO status 0010000
ATUS 8

Bit	31	30	29	28	27	26	25	24	23	22	21	20	19	18	17	16
Name	RSV0								CH TX_DM A_F AU LT	CH TX_OV RU N	CH TX_UN RU N	CH TX_TH RE S	CH RX_DM A_F AU LT	CH RX_OV RU N	CH RX_UN RU N	CH RX_TH RE S
Type	RO								W1 C	W1 C	W1 C	W1 C	W1 C	W1 C	W1 C	W1 C
Reset	0	0	0	0	0	0	0	0	0	0	0	1	0	0	0	0
Bit	15	14	13	12	11	10	9	8	7	6	5	4	3	2	1	0
Name	RSV1								CHRFF_AVCNT				CHTFF_EPCNT			
Type	RO								RO				RO			
Reset	0	0	0	0	0	0	0	0	0	0	0	0	1	0	0	0

Bit(s)	Name	Description
31:24	RSV0	Reserved
23	CHTX_DMA_FAULT	Tx DMA Fault Detected Interrupt, Asserts when a fault is detected in a Channel B0 Tx DMA signal.
22	CHTX_OVRUN	Tx Overrun Interrupt, Asserts when the Channel B0 Tx FIFO is overrun.
21	CHTX_UNRUN	Tx FIFO Underrun Interrupt, Asserts when the Channel B0 Tx FIFO is underrun.
20	CHTX_THRES	Tx FIFO Below Threshold Interrupt, Asserts when the Channel B0 FIFO is lower than the defined threshold.
19	CHRX_DMA_FAULT	Rx DMA Fault Detected Interrupt, Asserts when a fault is detected in a Channel B0 Rx DMA signal.
18	CHRX_OVRUN	Rx FIFO Overrun Interrupt, Asserts when the Channel B0 Rx FIFO is overrun.
17	CHRX_UNRUN	Rx FIFO Underrun Interrupt, Asserts when the Channel B0 Rx FIFO is underrun.
16	CHRX_THRES	Rx FIFO Below Threshold Interrupt, Asserts when the Channel B0 FIFO is lower than the defined threshold.
15:8	RSV1	Reserved
7:4	CHRFF_AVCNT	Channel B0 RXFIFO Available Space Count, Counts the available space for reads in channel B0 RXFIFO.(unit: word)
3:0	CHTFF_EPCNT	Channel B0 TXFIFO Available Space Count, Counts the available space for writes in channel B0 TXFIFO.(unit: word)

10002020 CHA0_CFG Channel A0(represents channel 0) Config 0000000
1

Bit	31	30	29	28	27	26	25	24	23	22	21	20	19	18	17	16
-----	----	----	----	----	----	----	----	----	----	----	----	----	----	----	----	----

Name	RSV0		CMP_MODE			RSV1[16:6]											
Type	RO		RW			RO											
Reset	0	0	0	0	0	0	0	0	0	0	0	0	0	0	0	0	0
Bit	15	14	13	12	11	10	9	8	7	6	5	4	3	2	1	0	
Name	RSV1[5:0]					TS_START											
Type	RO					RW											
Reset	0	0	0	0	0	0	0	0	0	0	0	0	0	0	0	0	1

Bit(s)	Name	Description
31:30	RSV0	Reserved
29:27	CMP_MODE	Compression Mode Sets the conversion method for the hardware converter to compress raw data. 000: Disable HW converter, linear raw data (16-bit) 010: Disable HW converter, linear raw data (8-bit), A-law or u-law (8-bit) 011: Reserved 100: Enable HW converter, raw data(16-bit) U-law mode (8-bit) (PCM bus in compressed format) 101: Enable HW converter, u-law mode (8-bit) raw data (16-bit) (PCM bus in raw, 16-bit format) 110: Enable HW converter, raw data (16-bit) A-law mode (8-bit) (PCM bus in compressed format) 111: Enable HW converter, A-law mode (8-bit) raw data (16-bit) (PCM bus in raw, 16-bit format) 0: DIS_CONV16 2: DIS_CONV8 4: EN_ULW2R 5: EN_R2ULW 6: EN_ALW2R 7: EN_R2ALW
26:10	RSV1	Reserved
9:0	TS_START	Timeslot starting location (unit: clock cycles)

10002024 **CHB0_CFG** Channel B0(represents channel 1) Config 0000000
1

Bit	31	30	29	28	27	26	25	24	23	22	21	20	19	18	17	16
Name	RSV0		CMP_MODE			RSV1[16:6]										
Type	RO		RW			RO										
Reset	0	0	0	0	0	0	0	0	0	0	0	0	0	0	0	0
Bit	15	14	13	12	11	10	9	8	7	6	5	4	3	2	1	0
Name	RSV1[5:0]					TS_START										
Type	RO					RW										
Reset	0	0	0	0	0	0	0	0	0	0	0	0	0	0	0	1

Bit(s)	Name	Description
31:30	RSV0	Reserved
29:27	CMP_MODE	Compression Mode Sets the conversion method for the hardware converter to compress raw data. 000: Disable HW converter, linear raw data (16-bit) 010: Disable HW converter, linear raw data (8-bit), A-law or u-law (8-bit) 011: Reserved 100: Enable HW converter, raw data(16-bit) U-law mode (8-bit) (PCM bus in compressed format) 101: Enable HW converter, u-law mode (8-bit) raw data (16-bit) (PCM bus in raw, 16-bit format) 110: Enable HW converter, raw data (16-bit) A-law mode (8-bit) (PCM bus in compressed format) 111: Enable HW converter, A-law mode (8-bit) raw data (16-bit) (PCM bus in raw, 16-bit format) 0: DIS_CONV16

Bit(s)	Name	Description
26:10	RSV1	Reserved
9:0	TS_START	Timeslot starting location (unit: clock cycles)

10002030 **FSYNC_CFG** **FSYNC config** **2800000**
0

Bit	31	30	29	28	27	26	25	24	23	22	21	20	19	18	17	16
Name	CFG_FSYNC_EN	POS_CAP_DT	POS_DRV_DT	POS_CAP_FSYNC	POS_DRV_FSYNC	RSV0					RSV1[11:6]					
Type	RW	RW	RW	RW	RW	RO					RO					
Reset	0	0	1	0	1	0	0	0	0	0	0	0	0	0	0	0
Bit	15	14	13	12	11	10	9	8	7	6	5	4	3	2	1	0
Name	RSV1[5:0]					FSYNC_INTV										
Type	RO					RW										
Reset	0	0	0	0	0	0	0	0	0	0	0	0	0	0	0	0

Bit(s)	Name	Description
31	CFG_FSYNC_EN	Enables configurable FSYNC.
30	POS_CAP_DT	Positive Edge Capture Data, Sets the PCM controller to capture data on the negative or positive edge of the PCM clock. NOTE: This configuration should be 0 if DTX_TRI=1.
29	POS_DRV_DT	Positive Edge Drive Data, Sets the PCM controller to drive data on the negative or positive edge of the PCM clock.
28	POS_CAP_FSYNC	Positive Edge Capture FSYNC, Sets the PCM controller to capture FSYNC on the positive or negative edge of the PCM clock.
27	POS_DRV_FSYNC	Positive Edge Driver FSYNC, Sets the PCM controller to drive FSYNC on the negative or positive edge of the PCM clock.
26:22	RSV0	Reserved
21:10	RSV1	Reserved
9:0	FSYNC_INTV	Interval when FSYNC may be configured. (unit: clock cycles)

10002034 **CHA0_CFG2** **Channel A0(represents channel 0) Config** **0000000**
0

Bit	31	30	29	28	27	26	25	24	23	22	21	20	19	18	17	16
Name	RSV0[27:12]															
Type	RO															
Reset	0	0	0	0	0	0	0	0	0	0	0	0	0	0	0	0
Bit	15	14	13	12	11	10	9	8	7	6	5	4	3	2	1	0
Name	RSV0[11:0]												CH_RX_FF_CL_R	CH_TX_FF_CL_R	RS_V1	CH_LS_B
Type	RO												RW	RW	RO	RW
Reset	0	0	0	0	0	0	0	0	0	0	0	0	0	0	0	0

Bit(s)	Name	Description
--------	------	-------------

Bit(s)	Name	Description
31:4	RSV0	Reserved
3	CH_RXFF_CLR	Channel A0 Rx FIFO Clear 0: Normal operation 1: Clear this bit
2	CH_TXFF_CLR	Channel A0 Tx FIFO Clear 0: Normal operation 1: Clear this bit
1	RSV1	Reserved
0	CH_LSB	Enable CH A0 Tx in LSB order.

10002038 **CHB0_CFG2** Channel B0(represents channel 1) Config 0000000
0

Bit	31	30	29	28	27	26	25	24	23	22	21	20	19	18	17	16
Name	RSV0[27:12]															
Type	RO															
Reset	0	0	0	0	0	0	0	0	0	0	0	0	0	0	0	0
Bit	15	14	13	12	11	10	9	8	7	6	5	4	3	2	1	0
Name	RSV0[11:0]												CH_RX_FF_CLR	CH_TX_FF_CLR	RSV1	CH_LSB
Type	RO												RW	RW	RO	RW
Reset	0	0	0	0	0	0	0	0	0	0	0	0	0	0	0	0

Bit(s)	Name	Description
31:4	RSV0	Reserved
3	CH_RXFF_CLR	Channel B0 Rx FIFO Clear 0: Normal operation 1: Clear this bit
2	CH_TXFF_CLR	Channel B0 Tx FIFO Clear 0: Normal operation 1: Clear this bit
1	RSV1	Reserved
0	CH_LSB	Enable CH B0 Tx in LSB order.

10002040 **IP_INFO** IP version info 0000040
1

Bit	31	30	29	28	27	26	25	24	23	22	21	20	19	18	17	16
Name	RSV0															
Type	RO															
Reset	0	0	0	0	0	0	0	0	0	0	0	0	0	0	0	0
Bit	15	14	13	12	11	10	9	8	7	6	5	4	3	2	1	0
Name	MAX_CH								VER							
Type	RO								RO							
Reset	0	0	0	0	0	1	0	0	0	0	0	0	0	0	0	1

Bit(s)	Name	Description
31:16	RSV0	Reserved
15:8	MAX_CH	Maximum channel number.
7:0	VER	Version of this PCM Controller

10002044 RSV_REG16 SPARE REG 16 bits 0000000
0

Bit	31	30	29	28	27	26	25	24	23	22	21	20	19	18	17	16
Name	RSV0															
Type	RO															
Reset	0	0	0	0	0	0	0	0	0	0	0	0	0	0	0	0
Bit	15	14	13	12	11	10	9	8	7	6	5	4	3	2	1	0
Name	SPARE_REG															
Type	RW															
Reset	0	0	0	0	0	0	0	0	0	0	0	0	0	0	0	0

Bit(s)	Name	Description
31:16	RSV0	Reserved
15:0	SPARE_REG	Spare register for future use

10002050 DIVCOMP_CF G Dividor Compensation part config 0000000
0

Bit	31	30	29	28	27	26	25	24	23	22	21	20	19	18	17	16
Name	CLK_EN	RSV0[22:8]														
Type	RW	RO														
Reset	0	0	0	0	0	0	0	0	0	0	0	0	0	0	0	0
Bit	15	14	13	12	11	10	9	8	7	6	5	4	3	2	1	0
Name	RSV0[7:0]							DIVCOMP								
Type	RO							RW								
Reset	0	0	0	0	0	0	0	0	0	0	0	0	0	0	0	0

Bit(s)	Name	Description
31	CLK_EN	Clock Enable Enables setting of the PCM interface clock based on DIVCOMP and DIVINT parameters.
30:8	RSV0	Reserved
7:0	DIVCOMP	A parameter in an equation which determines FREQOUT. See DIVINT.

10002054 DIVINT_CFG Dividor Integer part config 0000000
0

Bit	31	30	29	28	27	26	25	24	23	22	21	20	19	18	17	16
Name	RSV0[21:6]															
Type	RO															
Reset	0	0	0	0	0	0	0	0	0	0	0	0	0	0	0	0
Bit	15	14	13	12	11	10	9	8	7	6	5	4	3	2	1	0
Name	RSV0[5:0]							DIVINT								
Type	RO							RW								
Reset	0	0	0	0	0	0	0	0	0	0	0	0	0	0	0	0

Bit(s)	Name	Description
31:10	RSV0	Reserved
9:0	DIVINT	A parameter in an equation which determines FREQOUT. Formula: FREQOUT = 1/(FREQIN*2*(DIVINT+DIVCOMP/(2^8))) FREQIN is always fixed to 40 MHz.

10002060 DIGDELAY_C Digital delay config 0000000

FG

2

Bit	31	30	29	28	27	26	25	24	23	22	21	20	19	18	17	16
Name	TXD_CLR_GLT	CHEN_CLR_GLT	RSV0			TXD_GLT_ST	RSV1			CHEN_NEG_GLT_ST	RSV2			CHENP_GLT_ST	RSV3	CHENPD_GLT_ST
Type	RW	RW	RO			RW	RO			RW	RO			RW	RO	RW
Reset	0	0	0	0	0	0	0	0	0	0	0	0	0	0	0	0
Bit	15	14	13	12	11	10	9	8	7	6	5	4	3	2	1	0
Name	TXD_DIGDLY_EN	RSV4		TXD_DLYVAL					CHEN_DIGDLY_EN	RSV5		CHEN_DLYVAL				
Type	RW	RO		RW					RW	RO		RW				
Reset	0	0	0	0	0	0	0	0	0	0	0	0	0	0	1	0

Bit(s)	Name	Description
31	TXD_CLR_GLT	TXD Clear Glitch Flag Clears the glitch detected flag for TXD. 0: No effect. 1: Clear the flag.
30	CHEN_CLR_GLT	Channel Enable (CHEN) Clear Glitch Flag Clears the glitch detected flag for CHEN. 0: No effect . 1: Clear the flag.
29:27	RSV0	Reserved
26	TXD_GLT_ST	TXD Glitch Status Indicates if a glitch is detected in a TXD signal. It can be cleared by bit[31]. 0: Not detected. 1: Detected
25:23	RSV1	Reserved
22	CHEN_NEG_GLT_ST	CHEN Negative Glitch Status Indicates if a glitch is detected in a CHEN signal. It can be cleared by bit[30] (negedge sample). 0: Not detected. 1: Detected
21:19	RSV2	Reserved
18	CHENP_GLT_ST	CHEN Positive Glitch Status Indicates if a glitch is detected in a CHEN signal. It can be cleared by bit[30] (posedge sample). 0: Not detected. 1: Detected
17	RSV3	Reserved
16	CHENPD_GLT_ST	CHEN Positive Delay Glitch Status Indicates if a glitch is detected in a CHEN signal. It can be cleared by bit[30] (posedge sample, delay 1 cycle). 0: Not detected. 1: Detected
15	TXD_DIGDLY_EN	TXD Digital Delay Enable Enables digital delay path. 0: Disable 1: Enable
14:13	RSV4	Reserved
12:8	TXD_DLYVAL	Delay Count Value The description is the same as the CHEN_DLYVAL field in this register. CHEN Digital Delay Enable, Enables the digital delay path. 0: Disable 1: Enable

Bit(s)	Name	Description
7	CHEN_DIGDLY_EN	CHEN Digital Delay Enable Enables the digital delay path. 0: Disable 1: Enable
6:5	RSV5	Reserved
4:0	CHEN_DLYVAL	Delay Count Value The delay error = CLK_PERIOD * (SYNC_DELAY + SYNC_DELTA + (DLYCNT_CFG) + 1) For example, DLYCNT_CFG = 4, (SYNC_DELAY is always fixed to 4) Final Delay = CLK_PERIOD * (2 + (-1/0/+1) + (4) + 1) = CLK_PERIOD * (6/7/8)= CLK_PERIOD * (6 to 8) = 25 ns to 33.3 ns NOTE: Period is 1/240 MHz = 4.1667 ns in MT7620.

10002080 **CH0_FIFO** **Channel 0 FIFO access point** **0000000**
0

Bit	31	30	29	28	27	26	25	24	23	22	21	20	19	18	17	16
Name	CH0_FIFO[31:16]															
Type	RW															
Reset	0	0	0	0	0	0	0	0	0	0	0	0	0	0	0	0
Bit	15	14	13	12	11	10	9	8	7	6	5	4	3	2	1	0
Name	CH0_FIFO[15:0]															
Type	RW															
Reset	0	0	0	0	0	0	0	0	0	0	0	0	0	0	0	0

Bit(s)	Name	Description
31:0	CH0_FIFO	Channel 0 FIFO access point

10002084 **CH1_FIFO** **Channel 1 FIFO access point** **0000000**
0

Bit	31	30	29	28	27	26	25	24	23	22	21	20	19	18	17	16
Name	CH1_FIFO[31:16]															
Type	RW															
Reset	0	0	0	0	0	0	0	0	0	0	0	0	0	0	0	0
Bit	15	14	13	12	11	10	9	8	7	6	5	4	3	2	1	0
Name	CH1_FIFO[15:0]															
Type	RW															
Reset	0	0	0	0	0	0	0	0	0	0	0	0	0	0	0	0

Bit(s)	Name	Description
31:0	CH1_FIFO	Channel 1 FIFO access point

10002088 **CH2_FIFO** **Channel 2 FIFO access point** **0000000**
0

Bit	31	30	29	28	27	26	25	24	23	22	21	20	19	18	17	16
Name	CH2_FIFO[31:16]															
Type	RW															
Reset	0	0	0	0	0	0	0	0	0	0	0	0	0	0	0	0
Bit	15	14	13	12	11	10	9	8	7	6	5	4	3	2	1	0
Name	CH2_FIFO[15:0]															
Type	RW															

Reset	0	0	0	0	0	0	0	0	0	0	0	0	0	0	0	0
--------------	---	---	---	---	---	---	---	---	---	---	---	---	---	---	---	---

Bit(s)	Name	Description
31:0	CH2_FIFO	Channel 2 FIFO access point

1000208C **CH3_FIFO** Channel 3 FIFO access point **0000000**
0

Bit	31	30	29	28	27	26	25	24	23	22	21	20	19	18	17	16
Name	CH3_FIFO[31:16]															
Type	RW															
Reset	0	0	0	0	0	0	0	0	0	0	0	0	0	0	0	0
Bit	15	14	13	12	11	10	9	8	7	6	5	4	3	2	1	0
Name	CH3_FIFO[15:0]															
Type	RW															
Reset	0	0	0	0	0	0	0	0	0	0	0	0	0	0	0	0

Bit(s)	Name	Description
31:0	CH3_FIFO	Channel 3 FIFO access point

10002110 **CHA1_FF_ST** Channel A1(represents channel 3) FIFO status **0010000**
ATUS **8**

Bit	31	30	29	28	27	26	25	24	23	22	21	20	19	18	17	16
Name	RSV0								CH TX_DM A_F AU LT	CH TX_OV RU N	CH TX_UN RU N	CH TX_TH RE S	CH RX_DM A_F AU LT	CH RX_OV RU N	CH RX_UN RU N	CH RX_TH RE S
Type	RO								W1 C	W1 C	W1 C	W1 C	W1 C	W1 C	W1 C	W1 C
Reset	0	0	0	0	0	0	0	0	0	0	0	1	0	0	0	0
Bit	15	14	13	12	11	10	9	8	7	6	5	4	3	2	1	0
Name	RSV1								CH RFF_AV CNT				CH TFF_E PCNT			
Type	RO								RO				RO			
Reset	0	0	0	0	0	0	0	0	0	0	0	0	1	0	0	0

Bit(s)	Name	Description
31:24	RSV0	Reserved
23	CHTX_DMA_FAULT	Tx DMA Fault Detected Interrupt, Asserts when a fault is detected in a Channel A1 Tx DMA signal.
22	CHTX_OVRUN	Tx Overrun Interrupt, Asserts when the Channel A0 Tx FIFO is overrun.
21	CHTX_UNRUN	Tx FIFO Underrun Interrupt, Asserts when the Channel A1 Tx FIFO is underrun.
20	CHTX_THRES	Tx FIFO Below Threshold Interrupt, Asserts when the Channel A0 FIFO is lower than the defined threshold.
19	CHRX_DMA_FAULT	Rx DMA Fault Detected Interrupt, Asserts when a fault is detected in a Channel A1 Rx DMA signal.
18	CHRX_OVRUN	Rx FIFO Overrun Interrupt, Asserts when the Channel A1 Rx FIFO is overrun.
17	CHRX_UNRUN	Rx FIFO Underrun Interrupt, Asserts when the Channel A1 Rx FIFO is underrun.
16	CHRX_THRES	Rx FIFO Below Threshold Interrupt, Asserts when the Channel A1 FIFO is lower than the defined threshold.
15:8	RSV1	Reserved
7:4	CH RFF_AV CNT	Channel A1 RXFIFO Available Space Count, Counts the available space for reads in channel A1 RXFIFO.(unit: word)

Bit(s)	Name	Description
3:0	CHTFF_EPCNT	Channel A1 TXFIFO Available Space Count,Counts the available space for writes in channel A1 TXFIFO.(unit: word)

10002114 **CHB1_FF_ST** Channel B1(represents channel 4) FIFO status 0010000
ATUS 8

Bit	31	30	29	28	27	26	25	24	23	22	21	20	19	18	17	16
Name	RSV0								CH TX_DMA_FAULT	CH TX_OVRUN	CH TX_UNRUN	CH TX_THRES	CH RX_DMA_FAULT	CH RX_OVRUN	CH RX_UNRUN	CH RX_THRES
Type	RO								W1C	W1C	W1C	W1C	W1C	W1C	W1C	W1C
Reset	0	0	0	0	0	0	0	0	0	0	0	1	0	0	0	0
Bit	15	14	13	12	11	10	9	8	7	6	5	4	3	2	1	0
Name	RSV1								CHRFF_AVCNT				CHTFF_EPCNT			
Type	RO								RO				RO			
Reset	0	0	0	0	0	0	0	0	0	0	0	0	1	0	0	0

Bit(s)	Name	Description
31:24	RSV0	Reserved
23	CHTX_DMA_FAULT	Tx DMA Fault Detected Interrupt,Asserts when a fault is detected in a Channel B1 Tx DMA signal.
22	CHTX_OVRUN	Tx Overrun Interrupt,Asserts when the Channel B0 Tx FIFO is overrun.
21	CHTX_UNRUN	Tx FIFO Underrun Interrupt,Asserts when the Channel B1 Tx FIFO is underrun.
20	CHTX_THRES	Tx FIFO Below Threshold Interrupt,Asserts when the Channel B1 FIFO is lower than the defined threshold.
19	CHRX_DMA_FAULT	Rx DMA Fault Detected Interrupt,Asserts when a fault is detected in a Channel B1 Rx DMA signal.
18	CHRX_OVRUN	Rx FIFO Overrun Interrupt,Asserts when the Channel B1 Rx FIFO is overrun.
17	CHRX_UNRUN	Rx FIFO Underrun Interrupt,Asserts when the Channel B1 Rx FIFO is underrun.
16	CHRX_THRES	Rx FIFO Below Threshold Interrupt,Asserts when the Channel B1 FIFO is lower than the defined threshold.
15:8	RSV1	Reserved
7:4	CHRFF_AVCNT	Channel B1 RXFIFO Available Space Count,Counts the available space for reads in channel B1 RXFIFO.(unit: word)
3:0	CHTFF_EPCNT	Channel B1 TXFIFO Available Space Count,Counts the available space for writes in channel B1 TXFIFO.(unit: word)

10002120 **CHA1_CFG** Channel A1(represents channel 3) Config 0000000
1

Bit	31	30	29	28	27	26	25	24	23	22	21	20	19	18	17	16
Name	RSV0		CMP_MODE			RSV1[16:6]										
Type	RO		RW			RO										
Reset	0	0	0	0	0	0	0	0	0	0	0	0	0	0	0	0
Bit	15	14	13	12	11	10	9	8	7	6	5	4	3	2	1	0
Name	RSV1[5:0]					TS_START										
Type	RO					RW										
Reset	0	0	0	0	0	0	0	0	0	0	0	0	0	0	0	1

Bit(s)	Name	Description
31:30	RSV0	Reserved

Bit(s)	Name	Description
29:27	CMP_MODE	Compression Mode Sets the conversion method for the hardware converter to compress raw data. 000: Disable HW converter, linear raw data (16-bit) 010: Disable HW converter, linear raw data (8-bit), A-law or u-law (8-bit) 011: Reserved 100: Enable HW converter, raw data(16-bit) U-law mode (8-bit) (PCM bus in compressed format) 101: Enable HW converter, u-law mode (8-bit) raw data (16-bit) (PCM bus in raw, 16-bit format) 110: Enable HW converter, raw data (16-bit) A-law mode (8-bit) (PCM bus in compressed format) 111: Enable HW converter, A-law mode (8-bit) raw data (16-bit) (PCM bus in raw, 16-bit format) 0: DIS_CONV16 2: DIS_CONV8 4: EN_ULW2R 5: EN_R2ULW 6: EN_ALW2R 7: EN_R2ALW
26:10	RSV1	Reserved
9:0	TS_START	Timeslot starting location (unit: clock cycles)

10002124 **CHB1_CFG** Channel B1(represents channel 1) Config 0000000
1

Bit	31	30	29	28	27	26	25	24	23	22	21	20	19	18	17	16
Name	RSV0		CMP_MODE			RSV1[16:6]										
Type	RO		RW			RO										
Reset	0	0	0	0	0	0	0	0	0	0	0	0	0	0	0	0
Bit	15	14	13	12	11	10	9	8	7	6	5	4	3	2	1	0
Name	RSV1[5:0]					TS_START										
Type	RO					RW										
Reset	0	0	0	0	0	0	0	0	0	0	0	0	0	0	0	1

Bit(s)	Name	Description
31:30	RSV0	Reserved
29:27	CMP_MODE	Compression Mode Sets the conversion method for the hardware converter to compress raw data. 000: Disable HW converter, linear raw data (16-bit) 010: Disable HW converter, linear raw data (8-bit), A-law or u-law (8-bit) 011: Reserved 100: Enable HW converter, raw data(16-bit) U-law mode (8-bit) (PCM bus in compressed format) 101: Enable HW converter, u-law mode (8-bit) raw data (16-bit) (PCM bus in raw, 16-bit format) 110: Enable HW converter, raw data (16-bit) A-law mode (8-bit) (PCM bus in compressed format) 111: Enable HW converter, A-law mode (8-bit) raw data (16-bit) (PCM bus in raw, 16-bit format) 0: DIS_CONV16 2: DIS_CONV8 4: EN_ULW2R 5: EN_R2ULW 6: EN_ALW2R 7: EN_R2ALW
26:10	RSV1	Reserved
9:0	TS_START	Timeslot starting location (unit: clock cycles)

10002134 CHA1_CFG2 Channel A1(represents channel 3) Config 0000000
0

Bit	31	30	29	28	27	26	25	24	23	22	21	20	19	18	17	16
Name	RSV0[27:12]															
Type	RO															
Reset	0	0	0	0	0	0	0	0	0	0	0	0	0	0	0	0
Bit	15	14	13	12	11	10	9	8	7	6	5	4	3	2	1	0
Name	RSV0[11:0]												CH_RX_FF_CLR	CH_TX_FF_CLR	RS_V1	CH_LSB
Type	RO												RW	RW	RO	RW
Reset	0	0	0	0	0	0	0	0	0	0	0	0	0	0	0	0

Bit(s)	Name	Description
31:4	RSV0	Reserved
3	CH_RXFF_CLR	Channel A1 Rx FIFO Clear 0: Normal operation 1: Clear this bit
2	CH_TXFF_CLR	Channel A1 Tx FIFO Clear 0: Normal operation 1: Clear this bit
1	RSV1	Reserved
0	CH_LSB	Enable CH A1 Tx in LSB order.

10002138 CHB1_CFG2 Channel B1(represents channel 4) Config 0000000
0

Bit	31	30	29	28	27	26	25	24	23	22	21	20	19	18	17	16
Name	RSV0[27:12]															
Type	RO															
Reset	0	0	0	0	0	0	0	0	0	0	0	0	0	0	0	0
Bit	15	14	13	12	11	10	9	8	7	6	5	4	3	2	1	0
Name	RSV0[11:0]												CH_RX_FF_CLR	CH_TX_FF_CLR	RS_V1	CH_LSB
Type	RO												RW	RW	RO	RW
Reset	0	0	0	0	0	0	0	0	0	0	0	0	0	0	0	0

Bit(s)	Name	Description
31:4	RSV0	Reserved
3	CH_RXFF_CLR	Channel B1 Rx FIFO Clear 0: Normal operation 1: Clear this bit
2	CH_TXFF_CLR	Channel B1 Tx FIFO Clear 0: Normal operation 1: Clear this bit
1	RSV1	Reserved
0	CH_LSB	Enable CH B1 Tx in LSB order.

5.15 Generic DMA Controller

5.15.1 Features

- Supports 16 DMA channels
- Supports 32 bit address.
- Maximum 65535 byte transfer
- Programmable DMA burst size (1, 2, 4, 8, 16 double word burst)
- Supports memory to memory, memory to peripheral, peripheral to memory, peripheral to peripheral transfers.
- Supports continuous mode.
- Supports division of target transfer count into 1 to 256 segments
- Support for combining different channels into a chain.
- Programmable hardware channel priority.
- Interrupts for each channel.

5.15.2 Block Diagram

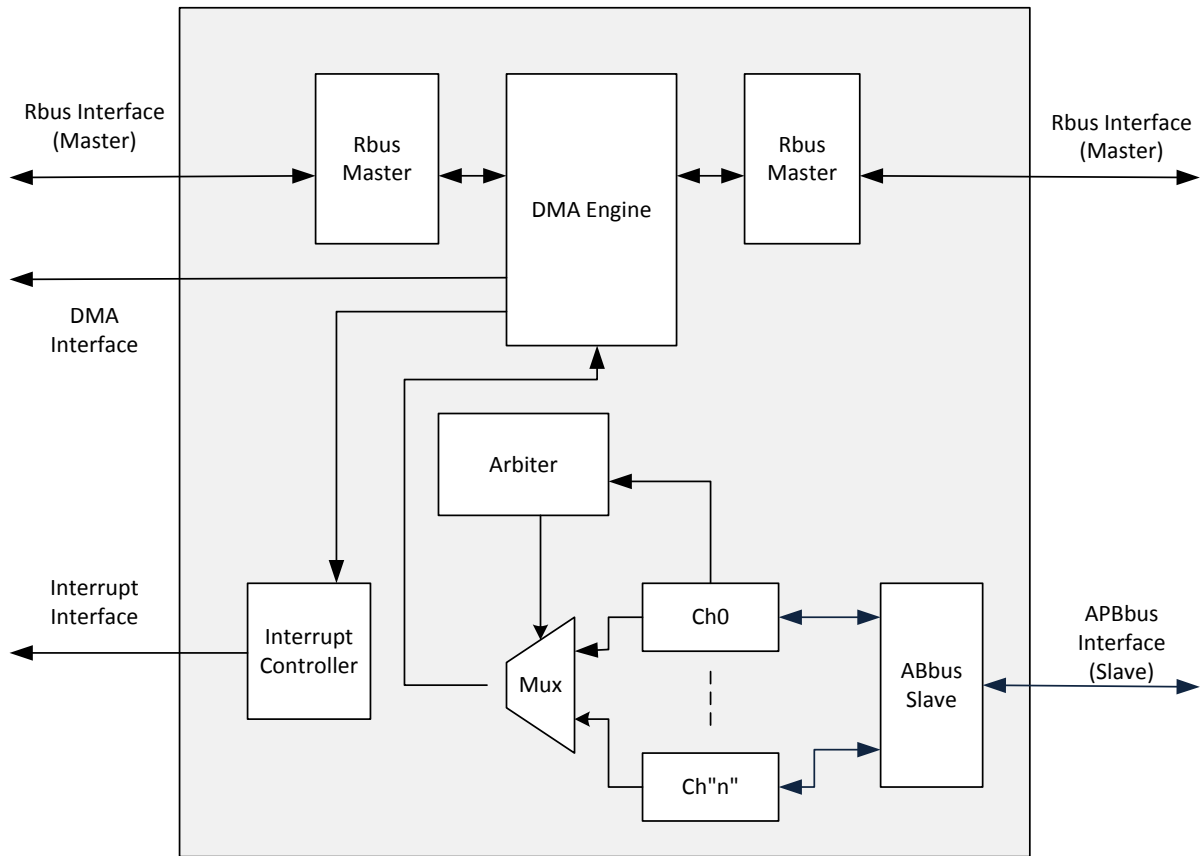

Figure 5-9 Generic DMA Controller Block Diagram

5.15.3 Peripheral Channel Connection

Channel number	Peripheral
0	Reserved
1	Reserved
2	I2S Controller (TXDMA)
3	I2S Controller (RXDMA)
4	PCM Controller (RDMA, channel-0)

Channel number	Peripheral
5	PCM Controller (RDMA, channel-1)
6	PCM Controller (TDMA, channel-0)
7	PCM Controller (TDMA, channel-1)
8	PCM Controller (RDMA, channel-2)
9	PCM Controller (RDMA, channel-3)
10	PCM Controller (TDMA, channel-2)
11	PCM Controller (TDMA, channel-3)
12	SPI Controller (RXDMA)
13	SPI Controller (TXDMA)
8 to 15	Reserved

5.15.4 Registers
GDMA Changes LOG

Revision	Date	Author	Change Log
0.1	2012/10/15	Mark Wang	Initialization

Module name: GDMA Base address: (+10002800h)

Address	Name	Width	Register Function
10002800	<u>GDMA_SA_0</u>	32	Source Address of GDMA Channel 0
10002804	<u>GDMA_DA_0</u>	32	Destination Address of GDMA Channel 0
10002808	<u>GDMA_CT0_0</u>	32	Control Register 0 of GDMA Channel 0
1000280C	<u>GDMA_CT1_0</u>	32	Control Register 1 of GDMA Channel 0
10002810	<u>GDMA_SA_1</u>	32	Source Address of GDMA Channel 1
10002814	<u>GDMA_DA_1</u>	32	Destination Address of GDMA Channel 1
10002818	<u>GDMA_CT0_1</u>	32	Control Register 0 of GDMA Channel 1
1000281C	<u>GDMA_CT1_1</u>	32	Control Register 1 of GDMA Channel 1
10002820	<u>GDMA_SA_2</u>	32	Source Address of GDMA Channel 2
10002824	<u>GDMA_DA_2</u>	32	Destination Address of GDMA Channel 2
10002828	<u>GDMA_CT0_2</u>	32	Control Register 0 of GDMA Channel 2
1000282C	<u>GDMA_CT1_2</u>	32	Control Register 1 of GDMA Channel 2
10002830	<u>GDMA_SA_3</u>	32	Source Address of GDMA Channel 3
10002834	<u>GDMA_DA_3</u>	32	Destination Address of GDMA Channel 3
10002838	<u>GDMA_CT0_3</u>	32	Control Register 0 of GDMA Channel 3
1000283C	<u>GDMA_CT1_3</u>	32	Control Register 1 of GDMA Channel 3
10002840	<u>GDMA_SA_4</u>	32	Source Address of GDMA Channel 4
10002844	<u>GDMA_DA_4</u>	32	Destination Address of GDMA Channel 4
10002848	<u>GDMA_CT0_4</u>	32	Control Register 0 of GDMA Channel 4
1000284C	<u>GDMA_CT1_4</u>	32	Control Register 1 of GDMA Channel 4
10002850	<u>GDMA_SA_5</u>	32	Source Address of GDMA Channel 5
10002854	<u>GDMA_DA_5</u>	32	Destination Address of GDMA Channel 5
10002858	<u>GDMA_CT0_5</u>	32	Control Register 0 of GDMA Channel 5
1000285C	<u>GDMA_CT1_5</u>	32	Control Register 1 of GDMA Channel 5
10002860	<u>GDMA_SA_6</u>	32	Source Address of GDMA Channel 6
10002864	<u>GDMA_DA_6</u>	32	Destination Address of GDMA Channel 6
10002868	<u>GDMA_CT0_6</u>	32	Control Register 0 of GDMA Channel 6
1000286C	<u>GDMA_CT1_6</u>	32	Control Register 1 of GDMA Channel 6

10002870	<u>GDMA SA 7</u>	32	Source Address of GDMA Channel 7
10002874	<u>GDMA DA 7</u>	32	Destination Address of GDMA Channel 7
10002878	<u>GDMA CT0 7</u>	32	Control Register 0 of GDMA Channel 7
1000287C	<u>GDMA CT1 7</u>	32	Control Register 1 of GDMA Channel 7
10002880	<u>GDMA SA 8</u>	32	Source Address of GDMA Channel 8
10002884	<u>GDMA DA 8</u>	32	Destination Address of GDMA Channel 8
10002888	<u>GDMA CT0 8</u>	32	Control Register 0 of GDMA Channel 8
1000288C	<u>GDMA CT1 8</u>	32	Control Register 1 of GDMA Channel 8
10002890	<u>GDMA SA 9</u>	32	Source Address of GDMA Channel 9
10002894	<u>GDMA DA 9</u>	32	Destination Address of GDMA Channel 9
10002898	<u>GDMA CT0 9</u>	32	Control Register 0 of GDMA Channel 9
1000289C	<u>GDMA CT1 9</u>	32	Control Register 1 of GDMA Channel 9
100028A0	<u>GDMA SA 10</u>	32	Source Address of GDMA Channel 10
100028A4	<u>GDMA DA 10</u>	32	Destination Address of GDMA Channel 10
100028A8	<u>GDMA CT0 10</u>	32	Control Register 0 of GDMA Channel 10
100028AC	<u>GDMA CT1 10</u>	32	Control Register 1 of GDMA Channel 10
100028B0	<u>GDMA SA 11</u>	32	Source Address of GDMA Channel 11
100028B4	<u>GDMA DA 11</u>	32	Destination Address of GDMA Channel 11
100028B8	<u>GDMA CT0 11</u>	32	Control Register 0 of GDMA Channel 11
100028BC	<u>GDMA CT1 11</u>	32	Control Register 1 of GDMA Channel 11
100028C0	<u>GDMA SA 12</u>	32	Source Address of GDMA Channel 12
100028C4	<u>GDMA DA 12</u>	32	Destination Address of GDMA Channel 12
100028C8	<u>GDMA CT0 12</u>	32	Control Register 0 of GDMA Channel 12
100028CC	<u>GDMA CT1 12</u>	32	Control Register 1 of GDMA Channel 12
100028D0	<u>GDMA SA 13</u>	32	Source Address of GDMA Channel 13
100028D4	<u>GDMA DA 13</u>	32	Destination Address of GDMA Channel 13
100028D8	<u>GDMA CT0 13</u>	32	Control Register 0 of GDMA Channel 13
100028DC	<u>GDMA CT1 13</u>	32	Control Register 1 of GDMA Channel 13
100028E0	<u>GDMA SA 14</u>	32	Source Address of GDMA Channel 14
100028E4	<u>GDMA DA 14</u>	32	Destination Address of GDMA Channel 14
100028E8	<u>GDMA CT0 14</u>	32	Control Register 0 of GDMA Channel 14
100028EC	<u>GDMA CT1 14</u>	32	Control Register 1 of GDMA Channel 14
100028F0	<u>GDMA SA 15</u>	32	Source Address of GDMA Channel 15
100028F4	<u>GDMA DA 15</u>	32	Destination Address of GDMA Channel 15
100028F8	<u>GDMA CT0 15</u>	32	Control Register 0 of GDMA Channel 15
100028FC	<u>GDMA CT1 15</u>	32	Control Register 1 of GDMA Channel 15
10002A00	<u>GDMA UNMASK INTSTS</u>	32	Unmask Fail Interrupt Status
10002A04	<u>GDMA DONE_INTERRUPTSTS</u>	32	Segment Done Interrupt Status
10002A20	<u>GDMA_GCT</u>	32	Global Control
10002A30	<u>GDMA_PERI_A_DDR_START_0</u>	32	Peripheral Region 0 Starting Address
10002A34	<u>GDMA_PERI_A_DDR_END_0</u>	32	Peripheral Region 0 End Address
10002A38	<u>GDMA_PERI_A_DDR_START_1</u>	32	Peripheral Region 1 Starting Address
10002A3C	<u>GDMA_PERI_A_DDR_END_1</u>	32	Peripheral Region 1 End Address
10002A40	<u>GDMA_PERI_A_DDR_START_2</u>	32	Peripheral Region 2 Starting Address
10002A44	<u>GDMA_PERI_A_DDR_END_2</u>	32	Peripheral Region 2 End Address
10002A48	<u>GDMA_PERI_A</u>	32	Peripheral Region 3 Starting Address

	<u>DDR_START_3</u>		
10002A4C	<u>GDMA_PERI_A</u> <u>DDR_END_3</u>	32	Peripheral Region 3 End Address

10002800 GDMA_SA_0 Source Address of GDMA Channel 0 **0000000**
0

Bit	31	30	29	28	27	26	25	24	23	22	21	20	19	18	17	16
Name	SOURCE_ADDR[31:16]															
Type	RW															
Reset	0	0	0	0	0	0	0	0	0	0	0	0	0	0	0	0
Bit	15	14	13	12	11	10	9	8	7	6	5	4	3	2	1	0
Name	SOURCE_ADDR[15:0]															
Type	RW															
Reset	0	0	0	0	0	0	0	0	0	0	0	0	0	0	0	0

Bit(s)	Name	Description
31:0	SOURCE_ADDR	Source address

10002804 GDMA_DA_0 Destination Address of GDMA Channel 0 **0000000**
0

Bit	31	30	29	28	27	26	25	24	23	22	21	20	19	18	17	16
Name	DEST_ADDR[31:16]															
Type	RW															
Reset	0	0	0	0	0	0	0	0	0	0	0	0	0	0	0	0
Bit	15	14	13	12	11	10	9	8	7	6	5	4	3	2	1	0
Name	DEST_ADDR[15:0]															
Type	RW															
Reset	0	0	0	0	0	0	0	0	0	0	0	0	0	0	0	0

Bit(s)	Name	Description
31:0	DEST_ADDR	Destination address

10002808 GDMA_CT0_0 Control Register 0 of GDMA Channel 0 **0000000**
0

Bit	31	30	29	28	27	26	25	24	23	22	21	20	19	18	17	16
Name	TARGET_BYTE_CNT															
Type	RW															
Reset	0	0	0	0	0	0	0	0	0	0	0	0	0	0	0	0
Bit	15	14	13	12	11	10	9	8	7	6	5	4	3	2	1	0
Name	CURR_SEGMENT								SOURCE_ADDR_MODE	DEST_ADDR_MODE	BURST_SIZE			SEGMENT_ENABLE	CH_EN	SW_MODE_EN
Type	RO								RW	RW	RW			RW	RW	RW
Reset	0	0	0	0	0	0	0	0	0	0	0	0	0	0	0	0

Bit(s)	Name	Description
31:16	TARGET_BYTE_CNT	The number of bytes to be transferred
15:8	CURR_SEGMENT	Indicates the current segment (0 to 255)
7	SOURCE_ADDR_MODE	Sets the source address mode 0: Incremental mode 1: Fix mode

Bit(s)	Name	Description
6	DEST_ADDR_MODE	Sets the destination address mode 0: Incremental mode 1: Fix mode
5:3	BURST_SIZE	Sets the number of double words in each burst transaction 0: 1 DW 1: 2 DWs 2: 4 DWs 3: 8 DWs 4: 16 DWs 5: Undefined 6: Undefined 7: Undefined
2	SEGMENT_DONE_INTERRUPT_EN	Enable the segment done interrupt. This interrupt asserts after transfer of each segment is done. 0: Disable 1: Enable
1	CH_EN	If CONT_MODE_EN=0, this bit is de-asserted by hardware after the number of bytes transferred reaches the TARGET_BYTE_CNT 0: Disable 1: Enable
0	SW_MODE_EN	Software mode enable. If software mode enable is set, the data transfer starts when the CH_EN bit is set. Otherwise, the data transfer starts when the DMA request is asserted. 0: Hardware mode 1: Software mode

1000280C GDMA_CT1_0 Control Register 1 of GDMA Channel 0

0000000
0

Bit	31	30	29	28	27	26	25	24	23	22	21	20	19	18	17	16	
Name	RESERVED						NUM_SEGMENT				SOURCE_DMA_REQ						
Type	RO						RW				RW						
Reset	0	0	0	0	0	0	0	0	0	0	0	0	0	0	0	0	
Bit	15	14	13	12	11	10	9	8	7	6	5	4	3	2	1	0	
Name	RESERVED	CONT_MODE_EN	DEST_DMA_REQ						NEXT_CH2UNMASK						COHERENT_INT_EN	CHANNEL_MASK	CHANNEL_MASK
Type	RO	RW	RW						RW						RW	RW	RW
Reset	0	0	0	0	0	0	0	0	0	0	0	0	0	0	0	0	

Bit(s)	Name	Description
25:22	NUM_SEGMENT	the number of segments=2N, where N is the value of this field. Valid values for this field are N=0 to 8. The segment size=(TARGET_BYTE_CNT/2N). If the TARGET_BYTE_CNT is not a multiple of 2N, the segment size = {(TARGET_BYTE_CNT/2N) + 1}.
21:16	SOURCE_DMA_REQ	Selects the source DMA request 0: DMA_REQ0 1: DMA_REQ1 2: DMA_REQ2 32: The source of the transfer is memory (always ready)
14	CONT_MODE_EN	If CONT_MODE_EN=1, HW will NOT clear CH_EN after the number of bytes transferred reaches TARGET_BYTE_CNT. Otherwise, HW will clear CH_EN will clear the CH_EN. 0: Continuous mode is disabled 1: Continuous mode is enabled

Bit(s)	Name	Description
13:8	DEST_DMA_REQ	Selects the destination DMA request 0: DMA_REQ0 1: DMA_REQ1 2: DMA_REQ2 32: The destination of the transfer is memory (always ready)
7:3	NEXT_CH2UNMASK	Selects the channel to clear the CH_MASK bit. When the number of bytes transferred reaches the TARGET_BYTE_CNT, the hardware will clear the CH_MASK field of the NEXT_CH2UNMASK channel. If the hardware does not need to clear CH_MASK field of any channel, this field should be set to the channel itself. 0: Channel 0 1: Channel 1 n: Channel n
2	COHERENT_INT_EN	If COHERENT_INT_EN is set, GDMA will issue a dummy read to destination after the last write to destination to avoid data coherent problem. Note: DO NOT set this field if the destination is not MEM. (may corrupt data, if destination is a FIFO) 0: Disable 1: Enable
1	CH_UNMASK_FAIL_INT_EN	If this field is set, an interrupt will be assert when HW detect the CH_MASK field of NEXT_CH2UNMASK channel is 1'b0 while trying to clear it. 0: Disable 1: Enable
0	CH_MASK	When this field is set, the transfer of this channel is gated until this field is clear by HW/SW. 0: Channel is not masked 1: Channel is masked

10002810 GDMA_SA_1 Source Address of GDMA Channel 1 0000000
0

Bit	31	30	29	28	27	26	25	24	23	22	21	20	19	18	17	16
Name	SOURCE_ADDR[31:16]															
Type	RW															
Reset	0	0	0	0	0	0	0	0	0	0	0	0	0	0	0	0
Bit	15	14	13	12	11	10	9	8	7	6	5	4	3	2	1	0
Name	SOURCE_ADDR[15:0]															
Type	RW															
Reset	0	0	0	0	0	0	0	0	0	0	0	0	0	0	0	0

Bit(s)	Name	Description
31:0	SOURCE_ADDR	Source address

10002814 GDMA_DA_1 Destination Address of GDMA Channel 1 0000000
0

Bit	31	30	29	28	27	26	25	24	23	22	21	20	19	18	17	16
Name	DEST_ADDR[31:16]															
Type	RW															
Reset	0	0	0	0	0	0	0	0	0	0	0	0	0	0	0	0
Bit	15	14	13	12	11	10	9	8	7	6	5	4	3	2	1	0
Name	DEST_ADDR[15:0]															
Type	RW															
Reset	0	0	0	0	0	0	0	0	0	0	0	0	0	0	0	0

Bit(s)	Name	Description
31:0	DEST_ADDR	Destination address

10002818 GDMA_CT0_1 Control Register 0 of GDMA Channel 1

0000000
0

Bit	31	30	29	28	27	26	25	24	23	22	21	20	19	18	17	16
Name	TARGET_BYTE_CNT															
Type	RW															
Reset	0	0	0	0	0	0	0	0	0	0	0	0	0	0	0	0
Bit	15	14	13	12	11	10	9	8	7	6	5	4	3	2	1	0
Name	CURR_SEGMENT								SOURCE_ADDR_MODE	DEST_ADDR_MODE	BURST_SIZE			SEGMENT_DONE_INTERRUPT_EN	CH_EN	SW_MODE_EN
Type	RO								RW	RW	RW			RW	RW	RW
Reset	0	0	0	0	0	0	0	0	0	0	0	0	0	0	0	0

Bit(s)	Name	Description
31:16	TARGET_BYTE_CNT	The number of bytes to be transferred
15:8	CURR_SEGMENT	Indicates the current segment (0 to 255)
7	SOURCE_ADDR_MODE	Sets the source address mode 0: Incremental mode 1: Fix mode
6	DEST_ADDR_MODE	Sets the destination address mode 0: Incremental mode 1: Fix mode
5:3	BURST_SIZE	Sets the number of double words in each burst transaction 0: 1 DW 1: 2 DWs 2: 4 DWs 3: 8 DWs 4: 16 DWs 5: Undefined 6: Undefined 7: Undefined
2	SEGMENT_DONE_INTERRUPT_EN	Enable the segment done interrupt. This interrupt asserts after transfer of each segment is done. 0: Disable 1: Enable
1	CH_EN	If CONT_MODE_EN=0, this bit is de-asserted by hardware after the number of bytes transferred reaches the TARGET_BYTE_CNT 0: Disable 1: Enable
0	SW_MODE_EN	Software mode enable. If software mode enable is set, the data transfer starts when the CH_EN bit is set. Otherwise, the data transfer starts when the DMA request is asserted. 0: Hardware mode 1: Software mode

1000281C GDMA_CT1_1 Control Register 1 of GDMA Channel 1

0000000
0

Bit	31	30	29	28	27	26	25	24	23	22	21	20	19	18	17	16
Name	RESERVED						NUM_SEGMENT				SOURCE_DMA_REQ					
Type	RO						RW				RW					
Reset	0	0	0	0	0	0	0	0	0	0	0	0	0	0	0	0
Bit	15	14	13	12	11	10	9	8	7	6	5	4	3	2	1	0
Name	RE	CO	DEST_DMA_REQ				NEXT_CH2UNMASK				CO	CH	CH			

	SE RV ED	NT_ MO DE_ EN									HE RE NT_ INT_ _EN	_U NM AS K_ F AIL IN T_ E N	_M AS K				
Type	RO	RW	RW								RW				RW	RW	RW
Reset	0	0	0	0	0	0	0	0	0	0	0	0	0	0	0	0	

Bit(s)	Name	Description
25:22	NUM_SEGMENT	the number of segments=2N, where N is the value of this field. Valid values for this field are N=0 to 8. The segment size=(TARGET_BYTE_CNT/2N). If the TARGET_BYTE_CNT is not a multiple of 2N, the segment size = {(TARGET_BYTE_CNT/2N) + 1}.
21:16	SOURCE_DMA_REQ	Selects the source DMA request 0: DMA_REQ0 1: DMA_REQ1 2: DMA_REQ2 32: The source of the transfer is memory (always ready)
14	CONT_MODE_EN	If CONT_MODE_EN=1, HW will NOT clear CH_EN after the number of bytes transferred reaches TARGET_BYTE_CNT. Otherwise, HW will clear CH_EN will clear the CH_EN. 0: Continuous mode is disabled 1: Continuous mode is enabled
13:8	DEST_DMA_REQ	Selects the destination DMA request 0: DMA_REQ0 1: DMA_REQ1 2: DMA_REQ2 32: The destination of the transfer is memory (always ready)
7:3	NEXT_CH2UNMASK	Selects the channel to clear the CH_MASK bit. When the number of bytes transferred reaches the TARGET_BYTE_CNT, the hardware will clear the CH_MASK field of the NEXT_CH2UNMASK channel. If the hardware does not need to clear CH_MASK field of any channel, this field should be set to the channel itself. 0: Channel 0 1: Channel 1 n: Channel n
2	COHERENT_INT_EN	If COHERENT_INT_EN is set, GDMA will issue a dummy read to destination after the last write to destination to avoid data coherent problem. Note: DO NOT set this field if the destination is not MEM. (may corrupt data, if destination is a FIFO) 0: Disable 1: Enable
1	CH_UNMASK_FAIL_INT_EN	If this field is set, an interrupt will be assert when HW detect the CH_MASK field of NEXT_CH2UNMASK channel is 1'b0 while trying to clear it. 0: Disable 1: Enable
0	CH_MASK	When this field is set, the transfer of this channel is gated until this field is clear by HW/SW. 0: Channel is not masked 1: Channel is masked

10002820 GDMA_SA_2 Source Address of GDMA Channel 2 0000000
0

Bit	31	30	29	28	27	26	25	24	23	22	21	20	19	18	17	16
Name	SOURCE_ADDR[31:16]															
Type	RW															
Reset	0	0	0	0	0	0	0	0	0	0	0	0	0	0	0	0
Bit	15	14	13	12	11	10	9	8	7	6	5	4	3	2	1	0

Name	SOURCE_ADDR[15:0]															
Type	RW															
Reset	0	0	0	0	0	0	0	0	0	0	0	0	0	0	0	0

Bit(s)	Name	Description
31:0	SOURCE_ADDR	Source address

10002824 **GDMA_DA_2** Destination Address of GDMA Channel 2 0000000
0

Bit	31	30	29	28	27	26	25	24	23	22	21	20	19	18	17	16
Name	DEST_ADDR[31:16]															
Type	RW															
Reset	0	0	0	0	0	0	0	0	0	0	0	0	0	0	0	0
Bit	15	14	13	12	11	10	9	8	7	6	5	4	3	2	1	0
Name	DEST_ADDR[15:0]															
Type	RW															
Reset	0	0	0	0	0	0	0	0	0	0	0	0	0	0	0	0

Bit(s)	Name	Description
31:0	DEST_ADDR	Destination address

10002828 **GDMA_CT0_2** Control Register 0 of GDMA Channel 2 0000000
0

Bit	31	30	29	28	27	26	25	24	23	22	21	20	19	18	17	16
Name	TARGET_BYTE_CNT															
Type	RW															
Reset	0	0	0	0	0	0	0	0	0	0	0	0	0	0	0	0
Bit	15	14	13	12	11	10	9	8	7	6	5	4	3	2	1	0
Name	CURR_SEGMENT								SOURCE_ADDR_MODE	DEST_ADDR_MODE	BURST_SIZE			SEGMENT_ENABLE	CHEN	SW_MODE_EN
Type	RO								RW	RW	RW			RW	RW	RW
Reset	0	0	0	0	0	0	0	0	0	0	0	0	0	0	0	0

Bit(s)	Name	Description
31:16	TARGET_BYTE_CNT	The number of bytes to be transferred
15:8	CURR_SEGMENT	Indicates the current segment (0 to 255)
7	SOURCE_ADDR_MODE	Sets the source address mode 0: Incremental mode 1: Fix mode
6	DEST_ADDR_MODE	Sets the destination address mode 0: Incremental mode 1: Fix mode
5:3	BURST_SIZE	Sets the number of double words in each burst transaction 0: 1 DW 1: 2 DWs 2: 4 DWs 3: 8 DWs 4: 16 DWs 5: Undefined 6: Undefined 7: Undefined

Bit(s)	Name	Description
2	SEGMENT_DONE_INTERRUPT_EN	Enable the segment done interrupt. This interrupt asserts after transfer of each segment is done. 0: Disable 1: Enable
1	CH_EN	If CONT_MODE_EN=0, this bit is de-asserted by hardware after the number of bytes transferred reaches the TARGET_BYTE_CNT 0: Disable 1: Enable
0	SW_MODE_EN	Software mode enable. If software mode enable is set, the data transfer starts when the CH_EN bit is set. Otherwise, the data transfer starts when the DMA request is asserted. 0: Hardware mode 1: Software mode

1000282C **GDMA_CT1_2** Control Register 1 of GDMA Channel 2 0000000
0

Bit	31	30	29	28	27	26	25	24	23	22	21	20	19	18	17	16	
Name	RESERVED						NUM_SEGMENT				SOURCE_DMA_REQ						
Type	RO						RW				RW						
Reset	0	0	0	0	0	0	0	0	0	0	0	0	0	0	0	0	
Bit	15	14	13	12	11	10	9	8	7	6	5	4	3	2	1	0	
Name	RESERVED	CONT_MODE_EN	DEST_DMA_REQ						NEXT_CH2UNMASK						COHERENT_INT_EN	CH_UNMASK_FAIL_INTEN	CH_MASK
Type	RO	RW	RW						RW						RW	RW	RW
Reset	0	0	0	0	0	0	0	0	0	0	0	0	0	0	0	0	

Bit(s)	Name	Description
25:22	NUM_SEGMENT	the number of segments=2N, where N is the value of this field. Valid values for this field are N=0 to 8. The segment size=(TARGET_BYTE_CNT/2N). If the TARGET_BYTE_CNT is not a multiple of 2N, the segment size = {(TARGET_BYTE_CNT/2N) + 1}.
21:16	SOURCE_DMA_REQ	Selects the source DMA request 0: DMA_REQ0 1: DMA_REQ1 2: DMA_REQ2 32: The source of the transfer is memory (always ready)
14	CONT_MODE_EN	If CONT_MODE_EN=1, HW will NOT clear CH_EN after the number of bytes transferred reaches TARGET_BYTE_CNT. Otherwise, HW will clear CH_EN will clear the CH_EN. 0: Continuous mode is disabled 1: Continuous mode is enabled
13:8	DEST_DMA_REQ	Selects the destination DMA request 0: DMA_REQ0 1: DMA_REQ1 2: DMA_REQ2 32: The destination of the transfer is memory (always ready)
7:3	NEXT_CH2UNMASK	Selects the channel to clear the CH_MASK bit. When the number of bytes transferred reaches the TARGET_BYTE_CNT, the hardware will clear the CH_MASK field of the NEXT_CH2UNMASK channel. If the hardware does not need to clear CH_MASK field of any channel, this field should be set to the channel itself. 0: Channel 0 1: Channel 1

Bit(s)	Name	Description
2	COHERENT_INT_EN	n: Channel n If COHERENT_INT_EN is set, GDMA will issue a dummy read to destination after the last write to destination to avoid data coherent problem. Note: DO NOT set this field if the destination is not MEM. (may corrupt data, if destination is a FIFO) 0: Disable 1: Enable
1	CH_UNMASK_FAIL_INT_EN	If this field is set, an interrupt will be assert when HW detect the CH_MASK field of NEXT_CH2UNMASK channel is 1'b0 while trying to clear it. 0: Disable 1: Enable
0	CH_MASK	When this field is set, the transfer of this channel is gated until this field is clear by HW/SW. 0: Channel is not masked 1: Channel is masked

10002830 **GDMA_SA_3** Source Address of GDMA Channel 3 0000000
0

Bit	31	30	29	28	27	26	25	24	23	22	21	20	19	18	17	16
Name	SOURCE_ADDR[31:16]															
Type	RW															
Reset	0	0	0	0	0	0	0	0	0	0	0	0	0	0	0	0
Bit	15	14	13	12	11	10	9	8	7	6	5	4	3	2	1	0
Name	SOURCE_ADDR[15:0]															
Type	RW															
Reset	0	0	0	0	0	0	0	0	0	0	0	0	0	0	0	0

Bit(s)	Name	Description
31:0	SOURCE_ADDR	Source address

10002834 **GDMA_DA_3** Destination Address of GDMA Channel 3 0000000
0

Bit	31	30	29	28	27	26	25	24	23	22	21	20	19	18	17	16
Name	DEST_ADDR[31:16]															
Type	RW															
Reset	0	0	0	0	0	0	0	0	0	0	0	0	0	0	0	0
Bit	15	14	13	12	11	10	9	8	7	6	5	4	3	2	1	0
Name	DEST_ADDR[15:0]															
Type	RW															
Reset	0	0	0	0	0	0	0	0	0	0	0	0	0	0	0	0

Bit(s)	Name	Description
31:0	DEST_ADDR	Destination address

10002838 **GDMA_CT0_3** Control Register 0 of GDMA Channel 3 0000000
0

Bit	31	30	29	28	27	26	25	24	23	22	21	20	19	18	17	16
Name	TARGET_BYTE_CNT															
Type	RW															
Reset	0	0	0	0	0	0	0	0	0	0	0	0	0	0	0	0
Bit	15	14	13	12	11	10	9	8	7	6	5	4	3	2	1	0
Name	CURR_SEGMENT								SO UR CE_	DE ST AD	BURST_SIZE			SE GM EN	CH _EN	SW _M OD

									AD DR _M OD E	DR _M OD E				T_D ON E_I NT_ EN		E_E N
Type	RO								RW	RW	RW			RW	RW	RW
Reset	0	0	0	0	0	0	0	0	0	0	0	0	0	0	0	0

Bit(s)	Name	Description
31:16	TARGET_BYTE_CNT	The number of bytes to be transferred
15:8	CURR_SEGMENT	Indicates the current segment (0 to 255)
7	SOURCE_ADDR_MODE	Sets the source address mode 0: Incremental mode 1: Fix mode
6	DEST_ADDR_MODE	Sets the destination address mode 0: Incremental mode 1: Fix mode
5:3	BURST_SIZE	Sets the number of double words in each burst transaction 0: 1 DW 1: 2 DWs 2: 4 DWs 3: 8 DWs 4: 16 DWs 5: Undefined 6: Undefined 7: Undefined
2	SEGMENT_DONE_INT_EN	Enable the segment done interrupt. This interrupt asserts after transfer of each segment is done. 0: Disable 1: Enable
1	CH_EN	If CONT_MODE_EN=0, this bit is de-asserted by hardware after the number of bytes transferred reaches the TARGET_BYTE_CNT 0: Disable 1: Enable
0	SW_MODE_EN	Software mode enable. If software mode enable is set, the data transfer starts when the CH_EN bit is set. Otherwise, the data transfer starts when the DMA request is asserted. 0: Hardware mode 1: Software mode

1000283C GDMA_CT1_3 Control Register 1 of GDMA Channel 3 0000000

Bit	31	30	29	28	27	26	25	24	23	22	21	20	19	18	17	16
Name	RESERVED						NUM_SEGMENT				SOURCE_DMA_REQ					
Type	RO						RW				RW					
Reset	0	0	0	0	0	0	0	0	0	0	0	0	0	0	0	0
Bit	15	14	13	12	11	10	9	8	7	6	5	4	3	2	1	0
Name	RE SE RV ED	CO NT_ MO DE_ EN	DEST_DMA_REQ				NEXT_CH2UNMASK				CO HE RE NT_ INT_ _EN	CH _U NM AS K_ F AIL IN T_ E N	CH _M AS K			
Type	RO	RW	RW				RW				RW	RW	RW			
Reset	0	0	0	0	0	0	0	0	0	0	0	0	0	0	0	0

Bit(s)	Name	Description
--------	------	-------------

Bit(s)	Name	Description
25:22	NUM_SEGMENT	the number of segments=2N, where N is the value of this field. Valid values for this field are N=0 to 8. The segment size=(TARGET_BYTE_CNT/2N). If the TARGET_BYTE_CNT is not a multiple of 2N, the segment size = {(TARGET_BYTE_CNT/2N) + 1}.
21:16	SOURCE_DMA_REQ	Selects the source DMA request 0: DMA_REQ0 1: DMA_REQ1 2: DMA_REQ2 32: The source of the transfer is memory (always ready)
14	CONT_MODE_EN	If CONT_MODE_EN=1, HW will NOT clear CH_EN after the number of bytes transferred reaches TARGET_BYTE_CNT. Otherwise, HW will clear CH_EN will clear the CH_EN. 0: Continuous mode is disabled 1: Continuous mode is enabled
13:8	DEST_DMA_REQ	Selects the destination DMA request 0: DMA_REQ0 1: DMA_REQ1 2: DMA_REQ2 32: The destination of the transfer is memory (always ready)
7:3	NEXT_CH2UNMASK	Selects the channel to clear the CH_MASK bit. When the number of bytes transferred reaches the TARGET_BYTE_CNT, the hardware will clear the CH_MASK field of the NEXT_CH2UNMASK channel. If the hardware does not need to clear CH_MASK field of any channel, this field should be set to the channel itself. 0: Channel 0 1: Channel 1 n: Channel n
2	COHERENT_INT_EN	If COHERENT_INT_EN is set, GDMA will issue a dummy read to destination after the last write to destination to avoid data coherent problem. Note: DO NOT set this field if the destination is not MEM. (may corrupt data, if destination is a FIFO) 0: Disable 1: Enable
1	CH_UNMASK_FAIL_INT_EN	If this field is set, an interrupt will be assert when HW detect the CH_MASK field of NEXT_CH2UNMASK channel is 1'b0 while trying to clear it. 0: Disable 1: Enable
0	CH_MASK	When this field is set, the transfer of this channel is gated until this field is clear by HW/SW. 0: Channel is not masked 1: Channel is masked

10002840 GDMA_SA 4 Source Address of GDMA Channel 4 0000000

Bit	31	30	29	28	27	26	25	24	23	22	21	20	19	18	17	16
Name	SOURCE_ADDR[31:16]															
Type	RW															
Reset	0	0	0	0	0	0	0	0	0	0	0	0	0	0	0	0
Bit	15	14	13	12	11	10	9	8	7	6	5	4	3	2	1	0
Name	SOURCE_ADDR[15:0]															
Type	RW															
Reset	0	0	0	0	0	0	0	0	0	0	0	0	0	0	0	0

Bit(s)	Name	Description
31:0	SOURCE_ADDR	Source address

10002844 GDMA_DA_4 Destination Address of GDMA Channel 4 0000000
0

Bit	31	30	29	28	27	26	25	24	23	22	21	20	19	18	17	16
Name	DEST_ADDR[31:16]															
Type	RW															
Reset	0	0	0	0	0	0	0	0	0	0	0	0	0	0	0	0
Bit	15	14	13	12	11	10	9	8	7	6	5	4	3	2	1	0
Name	DEST_ADDR[15:0]															
Type	RW															
Reset	0	0	0	0	0	0	0	0	0	0	0	0	0	0	0	0

Bit(s)	Name	Description
31:0	DEST_ADDR	Destination address

10002848 GDMA_CT0_4 Control Register 0 of GDMA Channel 4 0000000
0

Bit	31	30	29	28	27	26	25	24	23	22	21	20	19	18	17	16
Name	TARGET_BYTE_CNT															
Type	RW															
Reset	0	0	0	0	0	0	0	0	0	0	0	0	0	0	0	0
Bit	15	14	13	12	11	10	9	8	7	6	5	4	3	2	1	0
Name	CURR_SEGMENT								SOURCE_ADDR_MODE	DEST_ADDR_MODE	BURST_SIZE			SEGMENT_DONE_INTERRUPT_EN	CH_EN	SW_MODE_EN
Type	RO								RW	RW	RW			RW	RW	RW
Reset	0	0	0	0	0	0	0	0	0	0	0	0	0	0	0	0

Bit(s)	Name	Description
31:16	TARGET_BYTE_CNT	The number of bytes to be transferred
15:8	CURR_SEGMENT	Indicates the current segment (0 to 255)
7	SOURCE_ADDR_MODE	Sets the source address mode 0: Incremental mode 1: Fix mode
6	DEST_ADDR_MODE	Sets the destination address mode 0: Incremental mode 1: Fix mode
5:3	BURST_SIZE	Sets the number of double words in each burst transaction 0: 1 DW 1: 2 DWs 2: 4 DWs 3: 8 DWs 4: 16 DWs 5: Undefined 6: Undefined 7: Undefined
2	SEGMENT_DONE_INTERRUPT_EN	Enable the segment done interrupt. This interrupt asserts after transfer of each segment is done. 0: Disable 1: Enable
1	CH_EN	If CONT_MODE_EN=0, this bit is de-asserted by hardware after the number of bytes transferred reaches the TARGET_BYTE_CNT 0: Disable 1: Enable
0	SW_MODE_EN	Software mode enable. If software mode enable is set, the data transfer

Bit(s)	Name	Description
		starts when the CH_EN bit is set. Otherwise, the data transfer starts when the DMA request is asserted. 0: Hardware mode 1: Software mode

1000284C GDMA_CT1_4 Control Register 1 of GDMA Channel 4 0000000
0

Bit	31	30	29	28	27	26	25	24	23	22	21	20	19	18	17	16
Name	RESERVED				NUM_SEGMENT				SOURCE_DMA_REQ							
Type	RO				RW				RW							
Reset	0	0	0	0	0	0	0	0	0	0	0	0	0	0	0	0
Bit	15	14	13	12	11	10	9	8	7	6	5	4	3	2	1	0
Name	RESERVED	CONT_MODE_EN	DEST_DMA_REQ				NEXT_CH2UNMASK				COHERENT_INT_EN	CH_UNMASK_FAIL_INT_EN	CH_MASK			
Type	RO	RW	RW				RW				RW	RW	RW			
Reset	0	0	0	0	0	0	0	0	0	0	0	0	0	0	0	0

Bit(s)	Name	Description
25:22	NUM_SEGMENT	the number of segments=2N, where N is the value of this field. Valid values for this field are N=0 to 8. The segment size=(TARGET_BYTE_CNT/2N). If the TARGET_BYTE_CNT is not a multiple of 2N, the segment size = {(TARGET_BYTE_CNT/2N) + 1}.
21:16	SOURCE_DMA_REQ	Selects the source DMA request 0: DMA_REQ0 1: DMA_REQ1 2: DMA_REQ2 32: The source of the transfer is memory (always ready)
14	CONT_MODE_EN	If CONT_MODE_EN=1, HW will NOT clear CH_EN after the number of bytes transferred reaches TARGET_BYTE_CNT. Otherwise, HW will clear CH_EN will clear the CH_EN. 0: Continuous mode is disabled 1: Continuous mode is enabled
13:8	DEST_DMA_REQ	Selects the destination DMA request 0: DMA_REQ0 1: DMA_REQ1 2: DMA_REQ2 32: The destination of the transfer is memory (always ready)
7:3	NEXT_CH2UNMASK	Selects the channel to clear the CH_MASK bit. When the number of bytes transferred reaches the TARGET_BYTE_CNT, the hardware will clear the CH_MASK field of the NEXT_CH2UNMASK channel. If the hardware does not need to clear CH_MASK field of any channel, this field should be set to the channel itself. 0: Channel 0 1: Channel 1 n: Channel n
2	COHERENT_INT_EN	If COHERENT_INT_EN is set, GDMA will issue a dummy read to destination after the last write to destination to avoid data coherent problem. Note: DO NOT set this field if the destination is not MEM. (may corrupt data, if destination is a FIFO) 0: Disable 1: Enable
1	CH_UNMASK_FAIL_INT_EN	If this field is set, an interrupt will be assert when HW detect the CH_MASK field of NEXT_CH2UNMASK channel is 1'b0 while trying to clear it.

Bit(s)	Name	Description
0	CH_MASK	0: Disable 1: Enable When this field is set, the transfer of this channel is gated until this field is clear by HW/SW. 0: Channel is not masked 1: Channel is masked

10002850 **GDMA_SA_5** **Source Address of GDMA Channel 5** **0000000**
0

Bit	31	30	29	28	27	26	25	24	23	22	21	20	19	18	17	16
Name	SOURCE_ADDR[31:16]															
Type	RW															
Reset	0	0	0	0	0	0	0	0	0	0	0	0	0	0	0	0
Bit	15	14	13	12	11	10	9	8	7	6	5	4	3	2	1	0
Name	SOURCE_ADDR[15:0]															
Type	RW															
Reset	0	0	0	0	0	0	0	0	0	0	0	0	0	0	0	0

Bit(s)	Name	Description
31:0	SOURCE_ADDR	Source address

10002854 **GDMA_DA_5** **Destination Address of GDMA Channel 5** **0000000**
0

Bit	31	30	29	28	27	26	25	24	23	22	21	20	19	18	17	16
Name	DEST_ADDR[31:16]															
Type	RW															
Reset	0	0	0	0	0	0	0	0	0	0	0	0	0	0	0	0
Bit	15	14	13	12	11	10	9	8	7	6	5	4	3	2	1	0
Name	DEST_ADDR[15:0]															
Type	RW															
Reset	0	0	0	0	0	0	0	0	0	0	0	0	0	0	0	0

Bit(s)	Name	Description
31:0	DEST_ADDR	Destination address

10002858 **GDMA_CT0_5** **Control Register 0 of GDMA Channel 5** **0000000**
0

Bit	31	30	29	28	27	26	25	24	23	22	21	20	19	18	17	16
Name	TARGET_BYTE_CNT															
Type	RW															
Reset	0	0	0	0	0	0	0	0	0	0	0	0	0	0	0	0
Bit	15	14	13	12	11	10	9	8	7	6	5	4	3	2	1	0
Name	CURR_SEGMENT								SO UR CE_ AD DR _M OD E	DE ST_ AD DR _M OD E	BURST_SIZE			SE GM EN T_D ON E_I NT_ EN	CH _EN	SW _M OD E_E N
Type	RO								RW	RW	RW			RW	RW	RW
Reset	0	0	0	0	0	0	0	0	0	0	0	0	0	0	0	0

Bit(s)	Name	Description
31:16	TARGET_BYTE_CNT	The number of bytes to be transferred

Bit(s)	Name	Description
15:8	CURR_SEGMENT	Indicates the current segment (0 to 255)
7	SOURCE_ADDR_MODE	Sets the source address mode 0: Incremental mode 1: Fix mode
6	DEST_ADDR_MODE	Sets the destination address mode 0: Incremental mode 1: Fix mode
5:3	BURST_SIZE	Sets the number of double words in each burst transaction 0: 1 DW 1: 2 DWs 2: 4 DWs 3: 8 DWs 4: 16 DWs 5: Undefined 6: Undefined 7: Undefined
2	SEGMENT_DONE_INTERRUPT_EN	Enable the segment done interrupt. This interrupt asserts after transfer of each segment is done. 0: Disable 1: Enable
1	CH_EN	If CONT_MODE_EN=0, this bit is de-asserted by hardware after the number of bytes transferred reaches the TARGET_BYTE_CNT 0: Disable 1: Enable
0	SW_MODE_EN	Software mode enable. If software mode enable is set, the data transfer starts when the CH_EN bit is set. Otherwise, the data transfer starts when the DMA request is asserted. 0: Hardware mode 1: Software mode

1000285C **GDMA_CT1_5** Control Register 1 of GDMA Channel 5

0000000
0

Bit	31	30	29	28	27	26	25	24	23	22	21	20	19	18	17	16
Name	RESERVED						NUM_SEGMENT				SOURCE_DMA_REQ					
Type	RO						RW				RW					
Reset	0	0	0	0	0	0	0	0	0	0	0	0	0	0	0	0
Bit	15	14	13	12	11	10	9	8	7	6	5	4	3	2	1	0
Name	RESERVED	CONT_MODE_EN	DEST_DMA_REQ				NEXT_CH2UNMASK				CH_ERINT_EN	CH_UNMASK_FAIL_INTEN	CH_MASK			
Type	RO	RW	RW				RW				RW	RW	RW			
Reset	0	0	0	0	0	0	0	0	0	0	0	0	0	0	0	0

Bit(s)	Name	Description
25:22	NUM_SEGMENT	the number of segments=2N, where N is the value of this field. Valid values for this field are N=0 to 8. The segment size=(TARGET_BYTE_CNT/2N). If the TARGET_BYTE_CNT is not a multiple of 2N, the segment size = {(TARGET_BYTE_CNT/2N) + 1}.
21:16	SOURCE_DMA_REQ	Selects the source DMA request 0: DMA_REQ0 1: DMA_REQ1 2: DMA_REQ2 32: The source of the transfer is memory (always ready)
14	CONT_MODE_EN	If CONT_MODE_EN=1, HW will NOT clear CH_EN after the number of

Bit(s)	Name	Description
		bytes transferred reaches TARGET_BYTE_CNT. Otherwise, HW will clear CH_EN will clear the CH_EN. 0: Continuous mode is disabled 1: Continuous mode is enabled
13:8	DEST_DMA_REQ	Selects the destination DMA request 0: DMA_REQ0 1: DMA_REQ1 2: DMA_REQ2 32: The destination of the transfer is memory (always ready)
7:3	NEXT_CH2UNMASK	Selects the channel to clear the CH_MASK bit. When the number of bytes transferred reaches the TARGET_BYTE_CNT, the hardware will clear the CH_MASK field of the NEXT_CH2UNMASK channel. If the hardware does not need to clear CH_MASK field of any channel, this field should be set to the channel itself. 0: Channel 0 1: Channel 1 n: Channel n
2	COHERENT_INT_EN	If COHERENT_INT_EN is set, GDMA will issue a dummy read to destination after the last write to destination to avoid data coherent problem. Note: DO NOT set this field if the destination is not MEM. (may corrupt data, if destination is a FIFO) 0: Disable 1: Enable
1	CH_UNMASK_FAIL_INT_EN	If this field is set, an interrupt will be assert when HW detect the CH_MASK field of NEXT_CH2UNMASK channel is 1'b0 while trying to clear it. 0: Disable 1: Enable
0	CH_MASK	When this field is set, the transfer of this channel is gated until this field is clear by HW/SW. 0: Channel is not masked 1: Channel is masked

10002860 **GDMA_SA_6** Source Address of GDMA Channel 6 00000000

Bit	31	30	29	28	27	26	25	24	23	22	21	20	19	18	17	16
Name	SOURCE_ADDR[31:16]															
Type	RW															
Reset	0	0	0	0	0	0	0	0	0	0	0	0	0	0	0	0
Bit	15	14	13	12	11	10	9	8	7	6	5	4	3	2	1	0
Name	SOURCE_ADDR[15:0]															
Type	RW															
Reset	0	0	0	0	0	0	0	0	0	0	0	0	0	0	0	0

Bit(s)	Name	Description
31:0	SOURCE_ADDR	Source address

10002864 **GDMA_DA_6** Destination Address of GDMA Channel 6 00000000

Bit	31	30	29	28	27	26	25	24	23	22	21	20	19	18	17	16
Name	DEST_ADDR[31:16]															
Type	RW															
Reset	0	0	0	0	0	0	0	0	0	0	0	0	0	0	0	0
Bit	15	14	13	12	11	10	9	8	7	6	5	4	3	2	1	0
Name	DEST_ADDR[15:0]															
Type	RW															
Reset	0	0	0	0	0	0	0	0	0	0	0	0	0	0	0	0

Bit(s)	Name	Description
31:0	DEST_ADDR	Destination address

10002868 **GDMA_CT0_6** Control Register 0 of GDMA Channel 6 0000000
0

Bit	31	30	29	28	27	26	25	24	23	22	21	20	19	18	17	16
Name	TARGET_BYTE_CNT															
Type	RW															
Reset	0	0	0	0	0	0	0	0	0	0	0	0	0	0	0	0
Bit	15	14	13	12	11	10	9	8	7	6	5	4	3	2	1	0
Name	CURR_SEGMENT								SOURCE_ADDR_MODE	DEST_ADDR_MODE	BURST_SIZE			SEGMENT_DONE_INTERRUPT_EN	CH_EN	SW_MODE_EN
Type	RO								RW	RW	RW			RW	RW	RW
Reset	0	0	0	0	0	0	0	0	0	0	0	0	0	0	0	0

Bit(s)	Name	Description
31:16	TARGET_BYTE_CNT	The number of bytes to be transferred
15:8	CURR_SEGMENT	Indicates the current segment (0 to 255)
7	SOURCE_ADDR_MODE	Sets the source address mode 0: Incremental mode 1: Fix mode
6	DEST_ADDR_MODE	Sets the destination address mode 0: Incremental mode 1: Fix mode
5:3	BURST_SIZE	Sets the number of double words in each burst transaction 0: 1 DW 1: 2 DWs 2: 4 DWs 3: 8 DWs 4: 16 DWs 5: Undefined 6: Undefined 7: Undefined
2	SEGMENT_DONE_INTERRUPT_EN	Enable the segment done interrupt. This interrupt asserts after transfer of each segment is done. 0: Disable 1: Enable
1	CH_EN	If CONT_MODE_EN=0, this bit is de-asserted by hardware after the number of bytes transferred reaches the TARGET_BYTE_CNT 0: Disable 1: Enable
0	SW_MODE_EN	Software mode enable. If software mode enable is set, the data transfer starts when the CH_EN bit is set. Otherwise, the data transfer starts when the DMA request is asserted. 0: Hardware mode 1: Software mode

1000286C **GDMA_CT1_6** Control Register 1 of GDMA Channel 6 0000000
0

Bit	31	30	29	28	27	26	25	24	23	22	21	20	19	18	17	16
-----	----	----	----	----	----	----	----	----	----	----	----	----	----	----	----	----

Name	RESERVED						NUM_SEGMENT				SOURCE_DMA_REQ					
Type	RO						RW				RW					
Reset	0	0	0	0	0	0	0	0	0	0	0	0	0	0	0	0
Bit	15	14	13	12	11	10	9	8	7	6	5	4	3	2	1	0
Name	RESERVED	CONT_MODE_EN	DEST_DMA_REQ						NEXT_CH2UNMASK				COHERENT_INT_EN	CH_UNMASK_FAIL_INT_EN	CH_MASK	
Type	RO	RW	RW						RW				RW	RW	RW	
Reset	0	0	0	0	0	0	0	0	0	0	0	0	0	0	0	0

Bit(s)	Name	Description
25:22	NUM_SEGMENT	the number of segments=2N, where N is the value of this field. Valid values for this field are N=0 to 8. The segment size=(TARGET_BYTE_CNT/2N). If the TARGET_BYTE_CNT is not a multiple of 2N, the segment size = {(TARGET_BYTE_CNT/2N) + 1}.
21:16	SOURCE_DMA_REQ	Selects the source DMA request 0: DMA_REQ0 1: DMA_REQ1 2: DMA_REQ2 32: The source of the transfer is memory (always ready)
14	CONT_MODE_EN	If CONT_MODE_EN=1, HW will NOT clear CH_EN after the number of bytes transferred reaches TARGET_BYTE_CNT. Otherwise, HW will clear CH_EN will clear the CH_EN. 0: Continuous mode is disabled 1: Continuous mode is enabled
13:8	DEST_DMA_REQ	Selects the destination DMA request 0: DMA_REQ0 1: DMA_REQ1 2: DMA_REQ2 32: The destination of the transfer is memory (always ready)
7:3	NEXT_CH2UNMASK	Selects the channel to clear the CH_MASK bit. When the number of bytes transferred reaches the TARGET_BYTE_CNT, the hardware will clear the CH_MASK field of the NEXT_CH2UNMASK channel. If the hardware does not need to clear CH_MASK field of any channel, this field should be set to the channel itself. 0: Channel 0 1: Channel 1 n: Channel n
2	COHERENT_INT_EN	If COHERENT_INT_EN is set, GDMA will issue a dummy read to destination after the last write to destination to avoid data coherent problem. Note: DO NOT set this field if the destination is not MEM. (may corrupt data, if destination is a FIFO) 0: Disable 1: Enable
1	CH_UNMASK_FAIL_INT_EN	If this field is set, an interrupt will be assert when HW detect the CH_MASK field of NEXT_CH2UNMASK channel is 1'b0 while trying to clear it. 0: Disable 1: Enable
0	CH_MASK	When this field is set, the transfer of this channel is gated until this field is clear by HW/SW. 0: Channel is not masked 1: Channel is masked

10002870 GDMA_SA_7 Source Address of GDMA Channel 7

0000000

Bit	31	30	29	28	27	26	25	24	23	22	21	20	19	18	17	16
Name	SOURCE_ADDR[31:16]															
Type	RW															
Reset	0	0	0	0	0	0	0	0	0	0	0	0	0	0	0	0
Bit	15	14	13	12	11	10	9	8	7	6	5	4	3	2	1	0
Name	SOURCE_ADDR[15:0]															
Type	RW															
Reset	0	0	0	0	0	0	0	0	0	0	0	0	0	0	0	0

Bit(s)	Name	Description
31:0	SOURCE_ADDR	Source address

10002874 **GDMA_DA_7** Destination Address of GDMA Channel 7 0000000
0

Bit	31	30	29	28	27	26	25	24	23	22	21	20	19	18	17	16
Name	DEST_ADDR[31:16]															
Type	RW															
Reset	0	0	0	0	0	0	0	0	0	0	0	0	0	0	0	0
Bit	15	14	13	12	11	10	9	8	7	6	5	4	3	2	1	0
Name	DEST_ADDR[15:0]															
Type	RW															
Reset	0	0	0	0	0	0	0	0	0	0	0	0	0	0	0	0

Bit(s)	Name	Description
31:0	DEST_ADDR	Destination address

10002878 **GDMA_CT0_7** Control Register 0 of GDMA Channel 7 0000000
0

Bit	31	30	29	28	27	26	25	24	23	22	21	20	19	18	17	16
Name	TARGET_BYTE_CNT															
Type	RW															
Reset	0	0	0	0	0	0	0	0	0	0	0	0	0	0	0	0
Bit	15	14	13	12	11	10	9	8	7	6	5	4	3	2	1	0
Name	CURR_SEGMENT							SOURCE_ADDR_MODE	DEST_ADDR_MODE	BURST_SIZE			SEGMENT_ENABLE	CH_EN	SW_MODE_EN	
Type	RO							RW	RW	RW			RW	RW	RW	
Reset	0	0	0	0	0	0	0	0	0	0	0	0	0	0	0	0

Bit(s)	Name	Description
31:16	TARGET_BYTE_CNT	The number of bytes to be transferred
15:8	CURR_SEGMENT	Indicates the current segment (0 to 255)
7	SOURCE_ADDR_MODE	Sets the source address mode 0: Incremental mode 1: Fix mode
6	DEST_ADDR_MODE	Sets the destination address mode 0: Incremental mode 1: Fix mode
5:3	BURST_SIZE	Sets the number of double words in each burst transaction 0: 1 DW 1: 2 DWs 2: 4 DWs 3: 8 DWs

Bit(s)	Name	Description
		4: 16 DWs 5: Undefined 6: Undefined 7: Undefined
2	SEGMENT_DONE_INTERRUPT_EN	Enable the segment done interrupt. This interrupt asserts after transfer of each segment is done. 0: Disable 1: Enable
1	CH_EN	If CONT_MODE_EN=0, this bit is de-asserted by hardware after the number of bytes transferred reaches the TARGET_BYTE_CNT 0: Disable 1: Enable
0	SW_MODE_EN	Software mode enable. If software mode enable is set, the data transfer starts when the CH_EN bit is set. Otherwise, the data transfer starts when the DMA request is asserted. 0: Hardware mode 1: Software mode

1000287C GDMA_CT1_7 Control Register 1 of GDMA Channel 7

0000000
0

Bit	31	30	29	28	27	26	25	24	23	22	21	20	19	18	17	16
Name	RESERVED						NUM_SEGMENT				SOURCE_DMA_REQ					
Type	RO						RW				RW					
Reset	0	0	0	0	0	0	0	0	0	0	0	0	0	0	0	0
Bit	15	14	13	12	11	10	9	8	7	6	5	4	3	2	1	0
Name	RESERVED	CONT_MODE_EN	DEST_DMA_REQ				NEXT_CH2UNMASK				CHERENT_INT_EN	CHUNK_FAIL_IN_TEN	CH_MASK			
Type	RO	RW	RW				RW				RW	RW	RW			
Reset	0	0	0	0	0	0	0	0	0	0	0	0	0	0	0	0

Bit(s)	Name	Description
25:22	NUM_SEGMENT	the number of segments=2N, where N is the value of this field. Valid values for this field are N=0 to 8. The segment size=(TARGET_BYTE_CNT/2N). If the TARGET_BYTE_CNT is not a multiple of 2N, the segment size = {(TARGET_BYTE_CNT/2N) + 1}.
21:16	SOURCE_DMA_REQ	Selects the source DMA request 0: DMA_REQ0 1: DMA_REQ1 2: DMA_REQ2 32: The source of the transfer is memory (always ready)
14	CONT_MODE_EN	If CONT_MODE_EN=1, HW will NOT clear CH_EN after the number of bytes transferred reaches TARGET_BYTE_CNT. Otherwise, HW will clear CH_EN will clear the CH_EN. 0: Continuous mode is disabled 1: Continuous mode is enabled
13:8	DEST_DMA_REQ	Selects the destination DMA request 0: DMA_REQ0 1: DMA_REQ1 2: DMA_REQ2 32: The destination of the transfer is memory (always ready)
7:3	NEXT_CH2UNMASK	Selects the channel to clear the CH_MASK bit. When the number of bytes transferred reaches the TARGET_BYTE_CNT, the hardware will clear the CH_MASK field of the NEXT_CH2UNMASK channel. If the hardware does not need to clear CH_MASK field of any channel, this

Bit(s)	Name	Description
		field should be set to the channel itself. 0: Channel 0 1: Channel 1 n: Channel n
2	COHERENT_INT_EN	If COHERENT_INT_EN is set, GDMA will issue a dummy read to destination after the last write to destination to avoid data coherent problem. Note: DO NOT set this field if the destination is not MEM. (may corrupt data, if destination is a FIFO) 0: Disable 1: Enable
1	CH_UNMASK_FAIL_INT_EN	If this field is set, an interrupt will be assert when HW detect the CH_MASK field of NEXT_CH2UNMASK channel is 1'b0 while trying to clear it. 0: Disable 1: Enable
0	CH_MASK	When this field is set, the transfer of this channel is gated until this field is clear by HW/SW. 0: Channel is not masked 1: Channel is masked

10002880 **GDMA_SA_8** **Source Address of GDMA Channel 8** **0000000**
0

Bit	31	30	29	28	27	26	25	24	23	22	21	20	19	18	17	16
Name	SOURCE_ADDR[31:16]															
Type	RW															
Reset	0	0	0	0	0	0	0	0	0	0	0	0	0	0	0	0
Bit	15	14	13	12	11	10	9	8	7	6	5	4	3	2	1	0
Name	SOURCE_ADDR[15:0]															
Type	RW															
Reset	0	0	0	0	0	0	0	0	0	0	0	0	0	0	0	0

Bit(s)	Name	Description
31:0	SOURCE_ADDR	Source address

10002884 **GDMA_DA_8** **Destination Address of GDMA Channel 8** **0000000**
0

Bit	31	30	29	28	27	26	25	24	23	22	21	20	19	18	17	16
Name	DEST_ADDR[31:16]															
Type	RW															
Reset	0	0	0	0	0	0	0	0	0	0	0	0	0	0	0	0
Bit	15	14	13	12	11	10	9	8	7	6	5	4	3	2	1	0
Name	DEST_ADDR[15:0]															
Type	RW															
Reset	0	0	0	0	0	0	0	0	0	0	0	0	0	0	0	0

Bit(s)	Name	Description
31:0	DEST_ADDR	Destination address

10002888 **GDMA_CT0_8** **Control Register 0 of GDMA Channel 8** **0000000**
0

Bit	31	30	29	28	27	26	25	24	23	22	21	20	19	18	17	16
Name	TARGET_BYTE_CNT															
Type	RW															
Reset	0	0	0	0	0	0	0	0	0	0	0	0	0	0	0	0
Bit	15	14	13	12	11	10	9	8	7	6	5	4	3	2	1	0

Name	CURR_SEGMENT								SOURCE_ADDR_MODE	DEST_ADDR_MODE	BURST_SIZE			SEGMENT_DONE_INTERRUPT_EN	CH_EN	SW_MODE_EN
Type	RO								RW	RW	RW			RW	RW	RW
Reset	0	0	0	0	0	0	0	0	0	0	0	0	0	0	0	0

Bit(s)	Name	Description
31:16	TARGET_BYTE_CNT	The number of bytes to be transferred
15:8	CURR_SEGMENT	Indicates the current segment (0 to 255)
7	SOURCE_ADDR_MODE	Sets the source address mode 0: Incremental mode 1: Fix mode
6	DEST_ADDR_MODE	Sets the destination address mode 0: Incremental mode 1: Fix mode
5:3	BURST_SIZE	Sets the number of double words in each burst transaction 0: 1 DW 1: 2 DWs 2: 4 DWs 3: 8 DWs 4: 16 DWs 5: Undefined 6: Undefined 7: Undefined
2	SEGMENT_DONE_INTERRUPT_EN	Enable the segment done interrupt. This interrupt asserts after transfer of each segment is done. 0: Disable 1: Enable
1	CH_EN	If CONT_MODE_EN=0, this bit is de-asserted by hardware after the number of bytes transferred reaches the TARGET_BYTE_CNT 0: Disable 1: Enable
0	SW_MODE_EN	Software mode enable. If software mode enable is set, the data transfer starts when the CH_EN bit is set. Otherwise, the data transfer starts when the DMA request is asserted. 0: Hardware mode 1: Software mode

1000288C GDMA_CT1_8 Control Register 1 of GDMA Channel 8 0000000
0

Bit	31	30	29	28	27	26	25	24	23	22	21	20	19	18	17	16
Name	RESERVED						NUM_SEGMENT				SOURCE_DMA_REQ					
Type	RO						RW				RW					
Reset	0	0	0	0	0	0	0	0	0	0	0	0	0	0	0	0
Bit	15	14	13	12	11	10	9	8	7	6	5	4	3	2	1	0
Name	RESERVED	CONT_MODE_EN	DEST_DMA_REQ				NEXT_CH2UNMASK				CHERR_INTERRUPT_EN	CHUNMASK_AIL_INT_EN	CHMASK			
Type	RO	RW	RW				RW				RW	RW	RW			
Reset	0	0	0	0	0	0	0	0	0	0	0	0	0	0	0	0

Bit(s)	Name	Description
25:22	NUM_SEGMENT	the number of segments=2N, where N is the value of this field. Valid values for this field are N=0 to 8. The segment size=(TARGET_BYTE_CNT/2N). If the TARGET_BYTE_CNT is not a multiple of 2N, the segment size = {(TARGET_BYTE_CNT/2N) + 1}.
21:16	SOURCE_DMA_REQ	Selects the source DMA request 0: DMA_REQ0 1: DMA_REQ1 2: DMA_REQ2 32: The source of the transfer is memory (always ready)
14	CONT_MODE_EN	If CONT_MODE_EN=1, HW will NOT clear CH_EN after the number of bytes transferred reaches TARGET_BYTE_CNT. Otherwise, HW will clear CH_EN will clear the CH_EN. 0: Continuous mode is disabled 1: Continuous mode is enabled
13:8	DEST_DMA_REQ	Selects the destination DMA request 0: DMA_REQ0 1: DMA_REQ1 2: DMA_REQ2 32: The destination of the transfer is memory (always ready)
7:3	NEXT_CH2UNMASK	Selects the channel to clear the CH_MASK bit. When the number of bytes transferred reaches the TARGET_BYTE_CNT, the hardware will clear the CH_MASK field of the NEXT_CH2UNMASK channel. If the hardware does not need to clear CH_MASK field of any channel, this field should be set to the channel itself. 0: Channel 0 1: Channel 1 n: Channel n
2	COHERENT_INT_EN	If COHERENT_INT_EN is set, GDMA will issue a dummy read to destination after the last write to destination to avoid data coherent problem. Note: DO NOT set this field if the destination is not MEM. (may corrupt data, if destination is a FIFO) 0: Disable 1: Enable
1	CH_UNMASK_FAIL_INT_EN	If this field is set, an interrupt will be assert when HW detect the CH_MASK field of NEXT_CH2UNMASK channel is 1'b0 while trying to clear it. 0: Disable 1: Enable
0	CH_MASK	When this field is set, the transfer of this channel is gated until this field is clear by HW/SW. 0: Channel is not masked 1: Channel is masked

10002890 GDMA_SA 9 Source Address of GDMA Channel 9 0000000
0

Bit	31	30	29	28	27	26	25	24	23	22	21	20	19	18	17	16
Name	SOURCE_ADDR[31:16]															
Type	RW															
Reset	0	0	0	0	0	0	0	0	0	0	0	0	0	0	0	0
Bit	15	14	13	12	11	10	9	8	7	6	5	4	3	2	1	0
Name	SOURCE_ADDR[15:0]															
Type	RW															
Reset	0	0	0	0	0	0	0	0	0	0	0	0	0	0	0	0

Bit(s)	Name	Description
31:0	SOURCE_ADDR	Source address

10002894 GDMA_DA_9 Destination Address of GDMA Channel 9 0000000
0

Bit	31	30	29	28	27	26	25	24	23	22	21	20	19	18	17	16
Name	DEST_ADDR[31:16]															
Type	RW															
Reset	0	0	0	0	0	0	0	0	0	0	0	0	0	0	0	0
Bit	15	14	13	12	11	10	9	8	7	6	5	4	3	2	1	0
Name	DEST_ADDR[15:0]															
Type	RW															
Reset	0	0	0	0	0	0	0	0	0	0	0	0	0	0	0	0

Bit(s)	Name	Description
31:0	DEST_ADDR	Destination address

10002898 GDMA_CT0_9 Control Register 0 of GDMA Channel 9 0000000
0

Bit	31	30	29	28	27	26	25	24	23	22	21	20	19	18	17	16
Name	TARGET_BYTE_CNT															
Type	RW															
Reset	0	0	0	0	0	0	0	0	0	0	0	0	0	0	0	0
Bit	15	14	13	12	11	10	9	8	7	6	5	4	3	2	1	0
Name	CURR_SEGMENT								SOURCE_ADDR_MODE	DEST_ADDR_MODE	BURST_SIZE			SEGMENT_DONE_INTERRUPT_EN	CH_EN	SW_MODE_EN
Type	RO								RW	RW	RW			RW	RW	RW
Reset	0	0	0	0	0	0	0	0	0	0	0	0	0	0	0	0

Bit(s)	Name	Description
31:16	TARGET_BYTE_CNT	The number of bytes to be transferred
15:8	CURR_SEGMENT	Indicates the current segment (0 to 255)
7	SOURCE_ADDR_MODE	Sets the source address mode 0: Incremental mode 1: Fix mode
6	DEST_ADDR_MODE	Sets the destination address mode 0: Incremental mode 1: Fix mode
5:3	BURST_SIZE	Sets the number of double words in each burst transaction 0: 1 DW 1: 2 DWs 2: 4 DWs 3: 8 DWs 4: 16 DWs 5: Undefined 6: Undefined 7: Undefined
2	SEGMENT_DONE_INTERRUPT_EN	Enable the segment done interrupt. This interrupt asserts after transfer of each segment is done. 0: Disable 1: Enable
1	CH_EN	If CONT_MODE_EN=0, this bit is de-asserted by hardware after the number of bytes transferred reaches the TARGET_BYTE_CNT 0: Disable 1: Enable
0	SW_MODE_EN	Software mode enable. If software mode enable is set, the data transfer

Bit(s)	Name	Description
		starts when the CH_EN bit is set. Otherwise, the data transfer starts when the DMA request is asserted. 0: Hardware mode 1: Software mode

1000289C GDMA_CT1_9 Control Register 1 of GDMA Channel 9 0000000
0

Bit	31	30	29	28	27	26	25	24	23	22	21	20	19	18	17	16
Name	RESERVED				NUM_SEGMENT				SOURCE_DMA_REQ							
Type	RO				RW				RW							
Reset	0	0	0	0	0	0	0	0	0	0	0	0	0	0	0	0
Bit	15	14	13	12	11	10	9	8	7	6	5	4	3	2	1	0
Name	RESERVED	CONT_MODE_EN	DEST_DMA_REQ				NEXT_CH2UNMASK				COHERENT_INT_EN	CH_UNMASK_FAIL_INT_EN	CH_MASK			
Type	RO	RW	RW				RW				RW	RW	RW			
Reset	0	0	0	0	0	0	0	0	0	0	0	0	0	0	0	0

Bit(s)	Name	Description
25:22	NUM_SEGMENT	the number of segments=2N, where N is the value of this field. Valid values for this field are N=0 to 8. The segment size=(TARGET_BYTE_CNT/2N). If the TARGET_BYTE_CNT is not a multiple of 2N, the segment size = {(TARGET_BYTE_CNT/2N) + 1}.
21:16	SOURCE_DMA_REQ	Selects the source DMA request 0: DMA_REQ0 1: DMA_REQ1 2: DMA_REQ2 32: The source of the transfer is memory (always ready)
14	CONT_MODE_EN	If CONT_MODE_EN=1, HW will NOT clear CH_EN after the number of bytes transferred reaches TARGET_BYTE_CNT. Otherwise, HW will clear CH_EN will clear the CH_EN. 0: Continuous mode is disabled 1: Continuous mode is enabled
13:8	DEST_DMA_REQ	Selects the destination DMA request 0: DMA_REQ0 1: DMA_REQ1 2: DMA_REQ2 32: The destination of the transfer is memory (always ready)
7:3	NEXT_CH2UNMASK	Selects the channel to clear the CH_MASK bit. When the number of bytes transferred reaches the TARGET_BYTE_CNT, the hardware will clear the CH_MASK field of the NEXT_CH2UNMASK channel. If the hardware does not need to clear CH_MASK field of any channel, this field should be set to the channel itself. 0: Channel 0 1: Channel 1 n: Channel n
2	COHERENT_INT_EN	If COHERENT_INT_EN is set, GDMA will issue a dummy read to destination after the last write to destination to avoid data coherent problem. Note: DO NOT set this field if the destination is not MEM. (may corrupt data, if destination is a FIFO) 0: Disable 1: Enable
1	CH_UNMASK_FAIL_INT_EN	If this field is set, an interrupt will be assert when HW detect the CH_MASK field of NEXT_CH2UNMASK channel is 1'b0 while trying to clear it.

Bit(s)	Name	Description
0	CH_MASK	0: Disable 1: Enable When this field is set, the transfer of this channel is gated until this field is clear by HW/SW. 0: Channel is not masked 1: Channel is masked

100028A0 **GDMA_SA_10** **Source Address of GDMA Channel 10** **0000000**
0

Bit	31	30	29	28	27	26	25	24	23	22	21	20	19	18	17	16
Name	SOURCE_ADDR[31:16]															
Type	RW															
Reset	0	0	0	0	0	0	0	0	0	0	0	0	0	0	0	0
Bit	15	14	13	12	11	10	9	8	7	6	5	4	3	2	1	0
Name	SOURCE_ADDR[15:0]															
Type	RW															
Reset	0	0	0	0	0	0	0	0	0	0	0	0	0	0	0	0

Bit(s)	Name	Description
31:0	SOURCE_ADDR	Source address

100028A4 **GDMA_DA_10** **Destination Address of GDMA Channel 10** **0000000**
0

Bit	31	30	29	28	27	26	25	24	23	22	21	20	19	18	17	16
Name	DEST_ADDR[31:16]															
Type	RW															
Reset	0	0	0	0	0	0	0	0	0	0	0	0	0	0	0	0
Bit	15	14	13	12	11	10	9	8	7	6	5	4	3	2	1	0
Name	DEST_ADDR[15:0]															
Type	RW															
Reset	0	0	0	0	0	0	0	0	0	0	0	0	0	0	0	0

Bit(s)	Name	Description
31:0	DEST_ADDR	Destination address

100028A8 **GDMA_CT0_1** **Control Register 0 of GDMA Channel 10** **0000000**
0

Bit	31	30	29	28	27	26	25	24	23	22	21	20	19	18	17	16	
Name	TARGET_BYTE_CNT																
Type	RW																
Reset	0	0	0	0	0	0	0	0	0	0	0	0	0	0	0	0	
Bit	15	14	13	12	11	10	9	8	7	6	5	4	3	2	1	0	
Name	CURR_SEGMENT								SO UR CE_ AD DR _M OD E	DE ST_ AD DR _M OD E	BURST_SIZE				SE GM EN T_D ON E_I NT_ EN	CH _EN	SW _M OD E_E N
Type	RO								RW	RW	RW				RW	RW	RW
Reset	0	0	0	0	0	0	0	0	0	0	0	0	0	0	0	0	

Bit(s)	Name	Description
31:16	TARGET_BYTE_CNT	The number of bytes to be transferred

Bit(s)	Name	Description
15:8	CURR_SEGMENT	Indicates the current segment (0 to 255)
7	SOURCE_ADDR_MODE	Sets the source address mode 0: Incremental mode 1: Fix mode
6	DEST_ADDR_MODE	Sets the destination address mode 0: Incremental mode 1: Fix mode
5:3	BURST_SIZE	Sets the number of double words in each burst transaction 0: 1 DW 1: 2 DWs 2: 4 DWs 3: 8 DWs 4: 16 DWs 5: Undefined 6: Undefined 7: Undefined
2	SEGMENT_DONE_INTERRUPT_EN	Enable the segment done interrupt. This interrupt asserts after transfer of each segment is done. 0: Disable 1: Enable
1	CH_EN	If CONT_MODE_EN=0, this bit is de-asserted by hardware after the number of bytes transferred reaches the TARGET_BYTE_CNT 0: Disable 1: Enable
0	SW_MODE_EN	Software mode enable. If software mode enable is set, the data transfer starts when the CH_EN bit is set. Otherwise, the data transfer starts when the DMA request is asserted. 0: Hardware mode 1: Software mode

100028AC GDMA CT1 1 Control Register 1 of GDMA Channel 10 0000000
0

Bit	31	30	29	28	27	26	25	24	23	22	21	20	19	18	17	16
Name	RESERVED						NUM_SEGMENT				SOURCE_DMA_REQ					
Type	RO						RW				RW					
Reset	0	0	0	0	0	0	0	0	0	0	0	0	0	0	0	0
Bit	15	14	13	12	11	10	9	8	7	6	5	4	3	2	1	0
Name	RESERVED	CONT_MODE_EN	DEST_DMA_REQ				NEXT_CH2UNMASK				CHERINT_EN	CHUNMASK_FAIL_INTEN	CHMASK			
Type	RO	RW	RW				RW				RW	RW	RW			
Reset	0	0	0	0	0	0	0	0	0	0	0	0	0	0	0	0

Bit(s)	Name	Description
25:22	NUM_SEGMENT	the number of segments=2N, where N is the value of this field. Valid values for this field are N=0 to 8. The segment size=(TARGET_BYTE_CNT/2N). If the TARGET_BYTE_CNT is not a multiple of 2N, the segment size = {(TARGET_BYTE_CNT/2N) + 1}.
21:16	SOURCE_DMA_REQ	Selects the source DMA request 0: DMA_REQ0 1: DMA_REQ1 2: DMA_REQ2 32: The source of the transfer is memory (always ready)
14	CONT_MODE_EN	If CONT_MODE_EN=1, HW will NOT clear CH_EN after the number of

Bit(s)	Name	Description
		bytes transferred reaches TARGET_BYTE_CNT. Otherwise, HW will clear CH_EN will clear the CH_EN. 0: Continuous mode is disabled 1: Continuous mode is enabled
13:8	DEST_DMA_REQ	Selects the destination DMA request 0: DMA_REQ0 1: DMA_REQ1 2: DMA_REQ2 32: The destination of the transfer is memory (always ready)
7:3	NEXT_CH2UNMASK	Selects the channel to clear the CH_MASK bit. When the number of bytes transferred reaches the TARGET_BYTE_CNT, the hardware will clear the CH_MASK field of the NEXT_CH2UNMASK channel. If the hardware does not need to clear CH_MASK field of any channel, this field should be set to the channel itself. 0: Channel 0 1: Channel 1 n: Channel n
2	COHERENT_INT_EN	If COHERENT_INT_EN is set, GDMA will issue a dummy read to destination after the last write to destination to avoid data coherent problem. Note: DO NOT set this field if the destination is not MEM. (may corrupt data, if destination is a FIFO) 0: Disable 1: Enable
1	CH_UNMASK_FAIL_INT_EN	If this field is set, an interrupt will be assert when HW detect the CH_MASK field of NEXT_CH2UNMASK channel is 1'b0 while trying to clear it. 0: Disable 1: Enable
0	CH_MASK	When this field is set, the transfer of this channel is gated until this field is clear by HW/SW. 0: Channel is not masked 1: Channel is masked

100028B0 **GDMA SA 11** **Source Address of GDMA Channel 11** **0000000**
0

Bit	31	30	29	28	27	26	25	24	23	22	21	20	19	18	17	16
Name	SOURCE_ADDR[31:16]															
Type	RW															
Reset	0	0	0	0	0	0	0	0	0	0	0	0	0	0	0	0
Bit	15	14	13	12	11	10	9	8	7	6	5	4	3	2	1	0
Name	SOURCE_ADDR[15:0]															
Type	RW															
Reset	0	0	0	0	0	0	0	0	0	0	0	0	0	0	0	0

Bit(s)	Name	Description
31:0	SOURCE_ADDR	Source address

100028B4 **GDMA DA 11** **Destination Address of GDMA Channel 11** **0000000**
0

Bit	31	30	29	28	27	26	25	24	23	22	21	20	19	18	17	16
Name	DEST_ADDR[31:16]															
Type	RW															
Reset	0	0	0	0	0	0	0	0	0	0	0	0	0	0	0	0
Bit	15	14	13	12	11	10	9	8	7	6	5	4	3	2	1	0
Name	DEST_ADDR[15:0]															
Type	RW															
Reset	0	0	0	0	0	0	0	0	0	0	0	0	0	0	0	0

Bit(s)	Name	Description
31:0	DEST_ADDR	Destination address

100028B8 GDMA CT0 1 Control Register 0 of GDMA Channel 11 0000000
1 0

Bit	31	30	29	28	27	26	25	24	23	22	21	20	19	18	17	16
Name	TARGET_BYTE_CNT															
Type	RW															
Reset	0	0	0	0	0	0	0	0	0	0	0	0	0	0	0	0
Bit	15	14	13	12	11	10	9	8	7	6	5	4	3	2	1	0
Name	CURR_SEGMENT								SOURCE_ADDR_MODE	DEST_ADDR_MODE	BURST_SIZE			SEGMENT_DONE_INTERRUPT_EN	CH_EN	SW_MODE_EN
Type	RO								RW	RW	RW			RW	RW	RW
Reset	0	0	0	0	0	0	0	0	0	0	0	0	0	0	0	0

Bit(s)	Name	Description
31:16	TARGET_BYTE_CNT	The number of bytes to be transferred
15:8	CURR_SEGMENT	Indicates the current segment (0 to 255)
7	SOURCE_ADDR_MODE	Sets the source address mode 0: Incremental mode 1: Fix mode
6	DEST_ADDR_MODE	Sets the destination address mode 0: Incremental mode 1: Fix mode
5:3	BURST_SIZE	Sets the number of double words in each burst transaction 0: 1 DW 1: 2 DWs 2: 4 DWs 3: 8 DWs 4: 16 DWs 5: Undefined 6: Undefined 7: Undefined
2	SEGMENT_DONE_INTERRUPT_EN	Enable the segment done interrupt. This interrupt asserts after transfer of each segment is done. 0: Disable 1: Enable
1	CH_EN	If CONT_MODE_EN=0, this bit is de-asserted by hardware after the number of bytes transferred reaches the TARGET_BYTE_CNT 0: Disable 1: Enable
0	SW_MODE_EN	Software mode enable. If software mode enable is set, the data transfer starts when the CH_EN bit is set. Otherwise, the data transfer starts when the DMA request is asserted. 0: Hardware mode 1: Software mode

100028BC GDMA CT1 1 Control Register 1 of GDMA Channel 11 0000000
1 0

Bit	31	30	29	28	27	26	25	24	23	22	21	20	19	18	17	16
-----	----	----	----	----	----	----	----	----	----	----	----	----	----	----	----	----

Name	RESERVED						NUM_SEGMENT				SOURCE_DMA_REQ					
Type	RO						RW				RW					
Reset	0	0	0	0	0	0	0	0	0	0	0	0	0	0	0	0
Bit	15	14	13	12	11	10	9	8	7	6	5	4	3	2	1	0
Name	RESERVED	CONT_MODE_EN	DEST_DMA_REQ						NEXT_CH2UNMASK				COHERENT_INT_EN	CH_UNMASK_FAIL_INT_EN	CH_MASK	
Type	RO	RW	RW						RW				RW	RW	RW	
Reset	0	0	0	0	0	0	0	0	0	0	0	0	0	0	0	0

Bit(s)	Name	Description
25:22	NUM_SEGMENT	the number of segments=2N, where N is the value of this field. Valid values for this field are N=0 to 8. The segment size=(TARGET_BYTE_CNT/2N). If the TARGET_BYTE_CNT is not a multiple of 2N, the segment size = {(TARGET_BYTE_CNT/2N) + 1}.
21:16	SOURCE_DMA_REQ	Selects the source DMA request 0: DMA_REQ0 1: DMA_REQ1 2: DMA_REQ2 32: The source of the transfer is memory (always ready)
14	CONT_MODE_EN	If CONT_MODE_EN=1, HW will NOT clear CH_EN after the number of bytes transferred reaches TARGET_BYTE_CNT. Otherwise, HW will clear CH_EN will clear the CH_EN. 0: Continuous mode is disabled 1: Continuous mode is enabled
13:8	DEST_DMA_REQ	Selects the destination DMA request 0: DMA_REQ0 1: DMA_REQ1 2: DMA_REQ2 32: The destination of the transfer is memory (always ready)
7:3	NEXT_CH2UNMASK	Selects the channel to clear the CH_MASK bit. When the number of bytes transferred reaches the TARGET_BYTE_CNT, the hardware will clear the CH_MASK field of the NEXT_CH2UNMASK channel. If the hardware does not need to clear CH_MASK field of any channel, this field should be set to the channel itself. 0: Channel 0 1: Channel 1 n: Channel n
2	COHERENT_INT_EN	If COHERENT_INT_EN is set, GDMA will issue a dummy read to destination after the last write to destination to avoid data coherent problem. Note: DO NOT set this field if the destination is not MEM. (may corrupt data, if destination is a FIFO) 0: Disable 1: Enable
1	CH_UNMASK_FAIL_INT_EN	If this field is set, an interrupt will be assert when HW detect the CH_MASK field of NEXT_CH2UNMASK channel is 1'b0 while trying to clear it. 0: Disable 1: Enable
0	CH_MASK	When this field is set, the transfer of this channel is gated until this field is clear by HW/SW. 0: Channel is not masked 1: Channel is masked

100028C0 GDMA_SA_12 Source Address of GDMA Channel 12

0000000

Bit	31	30	29	28	27	26	25	24	23	22	21	20	19	18	17	16
Name	SOURCE_ADDR[31:16]															
Type	RW															
Reset	0	0	0	0	0	0	0	0	0	0	0	0	0	0	0	0
Bit	15	14	13	12	11	10	9	8	7	6	5	4	3	2	1	0
Name	SOURCE_ADDR[15:0]															
Type	RW															
Reset	0	0	0	0	0	0	0	0	0	0	0	0	0	0	0	0

Bit(s)	Name	Description
31:0	SOURCE_ADDR	Source address

100028C4 GDMA_DA_12 Destination Address of GDMA Channel 12 0000000
0

Bit	31	30	29	28	27	26	25	24	23	22	21	20	19	18	17	16
Name	DEST_ADDR[31:16]															
Type	RW															
Reset	0	0	0	0	0	0	0	0	0	0	0	0	0	0	0	0
Bit	15	14	13	12	11	10	9	8	7	6	5	4	3	2	1	0
Name	DEST_ADDR[15:0]															
Type	RW															
Reset	0	0	0	0	0	0	0	0	0	0	0	0	0	0	0	0

Bit(s)	Name	Description
31:0	DEST_ADDR	Destination address

100028C8 GDMA_CT0_1 Control Register 0 of GDMA Channel 12 0000000
0

Bit	31	30	29	28	27	26	25	24	23	22	21	20	19	18	17	16
Name	TARGET_BYTE_CNT															
Type	RW															
Reset	0	0	0	0	0	0	0	0	0	0	0	0	0	0	0	0
Bit	15	14	13	12	11	10	9	8	7	6	5	4	3	2	1	0
Name	CURR_SEGMENT							SOURCE_ADDR_MODE	DEST_ADDR_MODE	BURST_SIZE				SEGMENT_ENABLE	CH_EN	SW_MODE_EN
Type	RO							RW	RW	RW				RW	RW	RW
Reset	0	0	0	0	0	0	0	0	0	0	0	0	0	0	0	0

Bit(s)	Name	Description
31:16	TARGET_BYTE_CNT	The number of bytes to be transferred
15:8	CURR_SEGMENT	Indicates the current segment (0 to 255)
7	SOURCE_ADDR_MODE	Sets the source address mode 0: Incremental mode 1: Fix mode
6	DEST_ADDR_MODE	Sets the destination address mode 0: Incremental mode 1: Fix mode
5:3	BURST_SIZE	Sets the number of double words in each burst transaction 0: 1 DW 1: 2 DWs 2: 4 DWs 3: 8 DWs

Bit(s)	Name	Description
		4: 16 DWs 5: Undefined 6: Undefined 7: Undefined
2	SEGMENT_DONE_INTERRUPT_EN	Enable the segment done interrupt. This interrupt asserts after transfer of each segment is done. 0: Disable 1: Enable
1	CH_EN	If CONT_MODE_EN=0, this bit is de-asserted by hardware after the number of bytes transferred reaches the TARGET_BYTE_CNT 0: Disable 1: Enable
0	SW_MODE_EN	Software mode enable. If software mode enable is set, the data transfer starts when the CH_EN bit is set. Otherwise, the data transfer starts when the DMA request is asserted. 0: Hardware mode 1: Software mode

100028CC GDMA_CT1_1 Control Register 1 of GDMA Channel 12 0000000
2 0

Bit	31	30	29	28	27	26	25	24	23	22	21	20	19	18	17	16
Name	RESERVED						NUM_SEGMENT				SOURCE_DMA_REQ					
Type	RO						RW				RW					
Reset	0	0	0	0	0	0	0	0	0	0	0	0	0	0	0	0
Bit	15	14	13	12	11	10	9	8	7	6	5	4	3	2	1	0
Name	RESERVED	CONT_MODE_EN	DEST_DMA_REQ				NEXT_CH2UNMASK				CH2UNMASK_INT_EN	CH2UNMASK	CH_MASK			
Type	RO	RW	RW				RW				RW	RW	RW			
Reset	0	0	0	0	0	0	0	0	0	0	0	0	0	0	0	0

Bit(s)	Name	Description
25:22	NUM_SEGMENT	the number of segments=2N, where N is the value of this field. Valid values for this field are N=0 to 8. The segment size=(TARGET_BYTE_CNT/2N). If the TARGET_BYTE_CNT is not a multiple of 2N, the segment size = {(TARGET_BYTE_CNT/2N) + 1}.
21:16	SOURCE_DMA_REQ	Selects the source DMA request 0: DMA_REQ0 1: DMA_REQ1 2: DMA_REQ2 32: The source of the transfer is memory (always ready)
14	CONT_MODE_EN	If CONT_MODE_EN=1, HW will NOT clear CH_EN after the number of bytes transferred reaches TARGET_BYTE_CNT. Otherwise, HW will clear CH_EN will clear the CH_EN. 0: Continuous mode is disabled 1: Continuous mode is enabled
13:8	DEST_DMA_REQ	Selects the destination DMA request 0: DMA_REQ0 1: DMA_REQ1 2: DMA_REQ2 32: The destination of the transfer is memory (always ready)
7:3	NEXT_CH2UNMASK	Selects the channel to clear the CH_MASK bit. When the number of bytes transferred reaches the TARGET_BYTE_CNT, the hardware will clear the CH_MASK field of the NEXT_CH2UNMASK channel. If the hardware does not need to clear CH_MASK field of any channel, this

Bit(s)	Name	Description
		field should be set to the channel itself. 0: Channel 0 1: Channel 1 n: Channel n
2	COHERENT_INT_EN	If COHERENT_INT_EN is set, GDMA will issue a dummy read to destination after the last write to destination to avoid data coherent problem. Note: DO NOT set this field if the destination is not MEM. (may corrupt data, if destination is a FIFO) 0: Disable 1: Enable
1	CH_UNMASK_FAIL_INT_EN	If this field is set, an interrupt will be assert when HW detect the CH_MASK field of NEXT_CH2UNMASK channel is 1'b0 while trying to clear it. 0: Disable 1: Enable
0	CH_MASK	When this field is set, the transfer of this channel is gated until this field is clear by HW/SW. 0: Channel is not masked 1: Channel is masked

100028D0 **GDMA_SA_13** **Source Address of GDMA Channel 13** **0000000**
0

Bit	31	30	29	28	27	26	25	24	23	22	21	20	19	18	17	16
Name	SOURCE_ADDR[31:16]															
Type	RW															
Reset	0	0	0	0	0	0	0	0	0	0	0	0	0	0	0	0
Bit	15	14	13	12	11	10	9	8	7	6	5	4	3	2	1	0
Name	SOURCE_ADDR[15:0]															
Type	RW															
Reset	0	0	0	0	0	0	0	0	0	0	0	0	0	0	0	0

Bit(s)	Name	Description
31:0	SOURCE_ADDR	Source address

100028D4 **GDMA_DA_13** **Destination Address of GDMA Channel 13** **0000000**
0

Bit	31	30	29	28	27	26	25	24	23	22	21	20	19	18	17	16
Name	DEST_ADDR[31:16]															
Type	RW															
Reset	0	0	0	0	0	0	0	0	0	0	0	0	0	0	0	0
Bit	15	14	13	12	11	10	9	8	7	6	5	4	3	2	1	0
Name	DEST_ADDR[15:0]															
Type	RW															
Reset	0	0	0	0	0	0	0	0	0	0	0	0	0	0	0	0

Bit(s)	Name	Description
31:0	DEST_ADDR	Destination address

100028D8 **GDMA_CT0_1** **Control Register 0 of GDMA Channel 13** **0000000**
3 **0**

Bit	31	30	29	28	27	26	25	24	23	22	21	20	19	18	17	16
Name	TARGET_BYTE_CNT															
Type	RW															
Reset	0	0	0	0	0	0	0	0	0	0	0	0	0	0	0	0
Bit	15	14	13	12	11	10	9	8	7	6	5	4	3	2	1	0

Name	CURR_SEGMENT								SOURCE_ADDR_MODE	DEST_ADDR_MODE	BURST_SIZE			SEGMENT_DONE_INTERRUPT_EN	CH_EN	SW_MODE_EN
Type	RO								RW	RW	RW			RW	RW	RW
Reset	0	0	0	0	0	0	0	0	0	0	0	0	0	0	0	0

Bit(s)	Name	Description
31:16	TARGET_BYTE_CNT	The number of bytes to be transferred
15:8	CURR_SEGMENT	Indicates the current segment (0 to 255)
7	SOURCE_ADDR_MODE	Sets the source address mode 0: Incremental mode 1: Fix mode
6	DEST_ADDR_MODE	Sets the destination address mode 0: Incremental mode 1: Fix mode
5:3	BURST_SIZE	Sets the number of double words in each burst transaction 0: 1 DW 1: 2 DWs 2: 4 DWs 3: 8 DWs 4: 16 DWs 5: Undefined 6: Undefined 7: Undefined
2	SEGMENT_DONE_INTERRUPT_EN	Enable the segment done interrupt. This interrupt asserts after transfer of each segment is done. 0: Disable 1: Enable
1	CH_EN	If CONT_MODE_EN=0, this bit is de-asserted by hardware after the number of bytes transferred reaches the TARGET_BYTE_CNT 0: Disable 1: Enable
0	SW_MODE_EN	Software mode enable. If software mode enable is set, the data transfer starts when the CH_EN bit is set. Otherwise, the data transfer starts when the DMA request is asserted. 0: Hardware mode 1: Software mode

100028DC GDMA CT1 1 Control Register 1 of GDMA Channel 13 0000000
3 0

Bit	31	30	29	28	27	26	25	24	23	22	21	20	19	18	17	16
Name	RESERVED						NUM_SEGMENT				SOURCE_DMA_REQ					
Type	RO						RW				RW					
Reset	0	0	0	0	0	0	0	0	0	0	0	0	0	0	0	0
Bit	15	14	13	12	11	10	9	8	7	6	5	4	3	2	1	0
Name	RESERVED	CONT_MODE_EN	DEST_DMA_REQ						NEXT_CH2UNMASK				CHERR_INTERRUPT_EN	CHUNMASK_AIL_IN_TEN	CHMASK	
Type	RO	RW	RW						RW				RW	RW	RW	
Reset	0	0	0	0	0	0	0	0	0	0	0	0	0	0	0	0

Bit(s)	Name	Description
25:22	NUM_SEGMENT	the number of segments=2N, where N is the value of this field. Valid values for this field are N=0 to 8. The segment size=(TARGET_BYTE_CNT/2N). If the TARGET_BYTE_CNT is not a multiple of 2N, the segment size = {(TARGET_BYTE_CNT/2N) + 1}.
21:16	SOURCE_DMA_REQ	Selects the source DMA request 0: DMA_REQ0 1: DMA_REQ1 2: DMA_REQ2 32: The source of the transfer is memory (always ready)
14	CONT_MODE_EN	If CONT_MODE_EN=1, HW will NOT clear CH_EN after the number of bytes transferred reaches TARGET_BYTE_CNT. Otherwise, HW will clear CH_EN will clear the CH_EN. 0: Continuous mode is disabled 1: Continuous mode is enabled
13:8	DEST_DMA_REQ	Selects the destination DMA request 0: DMA_REQ0 1: DMA_REQ1 2: DMA_REQ2 32: The destination of the transfer is memory (always ready)
7:3	NEXT_CH2UNMASK	Selects the channel to clear the CH_MASK bit. When the number of bytes transferred reaches the TARGET_BYTE_CNT, the hardware will clear the CH_MASK field of the NEXT_CH2UNMASK channel. If the hardware does not need to clear CH_MASK field of any channel, this field should be set to the channel itself. 0: Channel 0 1: Channel 1 n: Channel n
2	COHERENT_INT_EN	If COHERENT_INT_EN is set, GDMA will issue a dummy read to destination after the last write to destination to avoid data coherent problem. Note: DO NOT set this field if the destination is not MEM. (may corrupt data, if destination is a FIFO) 0: Disable 1: Enable
1	CH_UNMASK_FAIL_INT_EN	If this field is set, an interrupt will be assert when HW detect the CH_MASK field of NEXT_CH2UNMASK channel is 1'b0 while trying to clear it. 0: Disable 1: Enable
0	CH_MASK	When this field is set, the transfer of this channel is gated until this field is clear by HW/SW. 0: Channel is not masked 1: Channel is masked

100028E0 GDMA_SA_14 Source Address of GDMA Channel 14 0000000

Bit	31	30	29	28	27	26	25	24	23	22	21	20	19	18	17	16
Name	SOURCE_ADDR[31:16]															
Type	RW															
Reset	0	0	0	0	0	0	0	0	0	0	0	0	0	0	0	0
Bit	15	14	13	12	11	10	9	8	7	6	5	4	3	2	1	0
Name	SOURCE_ADDR[15:0]															
Type	RW															
Reset	0	0	0	0	0	0	0	0	0	0	0	0	0	0	0	0

Bit(s)	Name	Description
31:0	SOURCE_ADDR	Source address

100028E4 GDMA_DA_14 Destination Address of GDMA Channel 14 0000000
0

Bit	31	30	29	28	27	26	25	24	23	22	21	20	19	18	17	16
Name	DEST_ADDR[31:16]															
Type	RW															
Reset	0	0	0	0	0	0	0	0	0	0	0	0	0	0	0	0
Bit	15	14	13	12	11	10	9	8	7	6	5	4	3	2	1	0
Name	DEST_ADDR[15:0]															
Type	RW															
Reset	0	0	0	0	0	0	0	0	0	0	0	0	0	0	0	0

Bit(s)	Name	Description
31:0	DEST_ADDR	Destination address

100028E8 GDMA_CT0_1 Control Register 0 of GDMA Channel 14 0000000
4 0

Bit	31	30	29	28	27	26	25	24	23	22	21	20	19	18	17	16
Name	TARGET_BYTE_CNT															
Type	RW															
Reset	0	0	0	0	0	0	0	0	0	0	0	0	0	0	0	0
Bit	15	14	13	12	11	10	9	8	7	6	5	4	3	2	1	0
Name	CURR_SEGMENT								SOURCE_ADDR_MODE	DEST_ADDR_MODE	BURST_SIZE			SEGMENT_DONE_INTERRUPT_EN	CH_EN	SW_MODE_EN
Type	RO								RW	RW	RW			RW	RW	RW
Reset	0	0	0	0	0	0	0	0	0	0	0	0	0	0	0	0

Bit(s)	Name	Description
31:16	TARGET_BYTE_CNT	The number of bytes to be transferred
15:8	CURR_SEGMENT	Indicates the current segment (0 to 255)
7	SOURCE_ADDR_MODE	Sets the source address mode 0: Incremental mode 1: Fix mode
6	DEST_ADDR_MODE	Sets the destination address mode 0: Incremental mode 1: Fix mode
5:3	BURST_SIZE	Sets the number of double words in each burst transaction 0: 1 DW 1: 2 DWs 2: 4 DWs 3: 8 DWs 4: 16 DWs 5: Undefined 6: Undefined 7: Undefined
2	SEGMENT_DONE_INTERRUPT_EN	Enable the segment done interrupt. This interrupt asserts after transfer of each segment is done. 0: Disable 1: Enable
1	CH_EN	If CONT_MODE_EN=0, this bit is de-asserted by hardware after the number of bytes transferred reaches the TARGET_BYTE_CNT 0: Disable 1: Enable
0	SW_MODE_EN	Software mode enable. If software mode enable is set, the data transfer

Bit(s)	Name	Description
		starts when the CH_EN bit is set. Otherwise, the data transfer starts when the DMA request is asserted. 0: Hardware mode 1: Software mode

100028EC GDMA_CT1_1 Control Register 1 of GDMA Channel 14 0000000
4 0

Bit	31	30	29	28	27	26	25	24	23	22	21	20	19	18	17	16
Name	RESERVED				NUM_SEGMENT				SOURCE_DMA_REQ							
Type	RO				RW				RW							
Reset	0	0	0	0	0	0	0	0	0	0	0	0	0	0	0	0
Bit	15	14	13	12	11	10	9	8	7	6	5	4	3	2	1	0
Name	RESERVED	CONT_MODE_EN	DEST_DMA_REQ				NEXT_CH2UNMASK				COHERENT_INT_EN	CH_UNMASK_FAIL_INT_EN	CH_MASK			
Type	RO	RW	RW				RW				RW	RW	RW			
Reset	0	0	0	0	0	0	0	0	0	0	0	0	0	0	0	0

Bit(s)	Name	Description
25:22	NUM_SEGMENT	the number of segments=2N, where N is the value of this field. Valid values for this field are N=0 to 8. The segment size=(TARGET_BYTE_CNT/2N). If the TARGET_BYTE_CNT is not a multiple of 2N, the segment size = {(TARGET_BYTE_CNT/2N) + 1}.
21:16	SOURCE_DMA_REQ	Selects the source DMA request 0: DMA_REQ0 1: DMA_REQ1 2: DMA_REQ2 32: The source of the transfer is memory (always ready)
14	CONT_MODE_EN	If CONT_MODE_EN=1, HW will NOT clear CH_EN after the number of bytes transferred reaches TARGET_BYTE_CNT. Otherwise, HW will clear CH_EN will clear the CH_EN. 0: Continuous mode is disabled 1: Continuous mode is enabled
13:8	DEST_DMA_REQ	Selects the destination DMA request 0: DMA_REQ0 1: DMA_REQ1 2: DMA_REQ2 32: The destination of the transfer is memory (always ready)
7:3	NEXT_CH2UNMASK	Selects the channel to clear the CH_MASK bit. When the number of bytes transferred reaches the TARGET_BYTE_CNT, the hardware will clear the CH_MASK field of the NEXT_CH2UNMASK channel. If the hardware does not need to clear CH_MASK field of any channel, this field should be set to the channel itself. 0: Channel 0 1: Channel 1 n: Channel n
2	COHERENT_INT_EN	If COHERENT_INT_EN is set, GDMA will issue a dummy read to destination after the last write to destination to avoid data coherent problem. Note: DO NOT set this field if the destination is not MEM. (may corrupt data, if destination is a FIFO) 0: Disable 1: Enable
1	CH_UNMASK_FAIL_INT_EN	If this field is set, an interrupt will be assert when HW detect the CH_MASK field of NEXT_CH2UNMASK channel is 1'b0 while trying to clear it.

Bit(s)	Name	Description
0	CH_MASK	0: Disable 1: Enable When this field is set, the transfer of this channel is gated until this field is clear by HW/SW. 0: Channel is not masked 1: Channel is masked

100028F0 **GDMA_SA_15** **Source Address of GDMA Channel 15** **0000000**
0

Bit	31	30	29	28	27	26	25	24	23	22	21	20	19	18	17	16
Name	SOURCE_ADDR[31:16]															
Type	RW															
Reset	0	0	0	0	0	0	0	0	0	0	0	0	0	0	0	0
Bit	15	14	13	12	11	10	9	8	7	6	5	4	3	2	1	0
Name	SOURCE_ADDR[15:0]															
Type	RW															
Reset	0	0	0	0	0	0	0	0	0	0	0	0	0	0	0	0

Bit(s)	Name	Description
31:0	SOURCE_ADDR	Source address

100028F4 **GDMA_DA_15** **Destination Address of GDMA Channel 15** **0000000**
0

Bit	31	30	29	28	27	26	25	24	23	22	21	20	19	18	17	16
Name	DEST_ADDR[31:16]															
Type	RW															
Reset	0	0	0	0	0	0	0	0	0	0	0	0	0	0	0	0
Bit	15	14	13	12	11	10	9	8	7	6	5	4	3	2	1	0
Name	DEST_ADDR[15:0]															
Type	RW															
Reset	0	0	0	0	0	0	0	0	0	0	0	0	0	0	0	0

Bit(s)	Name	Description
31:0	DEST_ADDR	Destination address

100028F8 **GDMA_CT0_1** **Control Register 0 of GDMA Channel 15** **0000000**
5 **0**

Bit	31	30	29	28	27	26	25	24	23	22	21	20	19	18	17	16
Name	TARGET_BYTE_CNT															
Type	RW															
Reset	0	0	0	0	0	0	0	0	0	0	0	0	0	0	0	0
Bit	15	14	13	12	11	10	9	8	7	6	5	4	3	2	1	0
Name	CURR_SEGMENT								SO UR CE_ AD DR _M OD E	DE ST_ AD DR _M OD E	BURST_SIZE			SE GM EN T_D ON E_I NT_ EN	CH _EN	SW _M OD E_E N
Type	RO								RW	RW	RW			RW	RW	RW
Reset	0	0	0	0	0	0	0	0	0	0	0	0	0	0	0	0

Bit(s)	Name	Description
31:16	TARGET_BYTE_CNT	The number of bytes to be transferred

Bit(s)	Name	Description
15:8	CURR_SEGMENT	Indicates the current segment (0 to 255)
7	SOURCE_ADDR_MODE	Sets the source address mode 0: Incremental mode 1: Fix mode
6	DEST_ADDR_MODE	Sets the destination address mode 0: Incremental mode 1: Fix mode
5:3	BURST_SIZE	Sets the number of double words in each burst transaction 0: 1 DW 1: 2 DWs 2: 4 DWs 3: 8 DWs 4: 16 DWs 5: Undefined 6: Undefined 7: Undefined
2	SEGMENT_DONE_INTERRUPT_EN	Enable the segment done interrupt. This interrupt asserts after transfer of each segment is done. 0: Disable 1: Enable
1	CH_EN	If CONT_MODE_EN=0, this bit is de-asserted by hardware after the number of bytes transferred reaches the TARGET_BYTE_CNT 0: Disable 1: Enable
0	SW_MODE_EN	Software mode enable. If software mode enable is set, the data transfer starts when the CH_EN bit is set. Otherwise, the data transfer starts when the DMA request is asserted. 0: Hardware mode 1: Software mode

100028FC GDMA CT1 1 Control Register 1 of GDMA Channel 15 0000000
5 0

Bit	31	30	29	28	27	26	25	24	23	22	21	20	19	18	17	16
Name	RESERVED						NUM_SEGMENT				SOURCE_DMA_REQ					
Type	RO						RW				RW					
Reset	0	0	0	0	0	0	0	0	0	0	0	0	0	0	0	0
Bit	15	14	13	12	11	10	9	8	7	6	5	4	3	2	1	0
Name	RESERVED	CONT_MODE_EN	DEST_DMA_REQ				NEXT_CH2UNMASK				CHERINT_EN	CHUNMASK_FAIL_INTEN	CHMASK			
Type	RO	RW	RW				RW				RW	RW	RW			
Reset	0	0	0	0	0	0	0	0	0	0	0	0	0	0	0	0

Bit(s)	Name	Description
25:22	NUM_SEGMENT	the number of segments=2N, where N is the value of this field. Valid values for this field are N=0 to 8. The segment size=(TARGET_BYTE_CNT/2N). If the TARGET_BYTE_CNT is not a multiple of 2N, the segment size = {(TARGET_BYTE_CNT/2N) + 1}.
21:16	SOURCE_DMA_REQ	Selects the source DMA request 0: DMA_REQ0 1: DMA_REQ1 2: DMA_REQ2 32: The source of the transfer is memory (always ready)
14	CONT_MODE_EN	If CONT_MODE_EN=1, HW will NOT clear CH_EN after the number of

Bit(s)	Name	Description
		bytes transferred reaches TARGET_BYTE_CNT. Otherwise, HW will clear CH_EN will clear the CH_EN. 0: Continuous mode is disabled 1: Continuous mode is enabled
13:8	DEST_DMA_REQ	Selects the destination DMA request 0: DMA_REQ0 1: DMA_REQ1 2: DMA_REQ2 32: The destination of the transfer is memory (always ready)
7:3	NEXT_CH2UNMASK	Selects the channel to clear the CH_MASK bit. When the number of bytes transferred reaches the TARGET_BYTE_CNT, the hardware will clear the CH_MASK field of the NEXT_CH2UNMASK channel. If the hardware does not need to clear CH_MASK field of any channel, this field should be set to the channel itself. 0: Channel 0 1: Channel 1 n: Channel n
2	COHERENT_INT_EN	If COHERENT_INT_EN is set, GDMA will issue a dummy read to destination after the last write to destination to avoid data coherent problem. Note: DO NOT set this field if the destination is not MEM. (may corrupt data, if destination is a FIFO) 0: Disable 1: Enable
1	CH_UNMASK_FAIL_INT_EN	If this field is set, an interrupt will be assert when HW detect the CH_MASK field of NEXT_CH2UNMASK channel is 1'b0 while trying to clear it. 0: Disable 1: Enable
0	CH_MASK	When this field is set, the transfer of this channel is gated until this field is clear by HW/SW. 0: Channel is not masked 1: Channel is masked

10002A00 GDMA_UNMASK_INTSTS Unmask Fail Interrupt Status 00000000

Bit	31	30	29	28	27	26	25	24	23	22	21	20	19	18	17	16
Name	UNMASK_FAIL_INTSTS[31:16]															
Type	W1C															
Reset	0	0	0	0	0	0	0	0	0	0	0	0	0	0	0	0
Bit	15	14	13	12	11	10	9	8	7	6	5	4	3	2	1	0
Name	UNMASK_FAIL_INTSTS[15:0]															
Type	W1C															
Reset	0	0	0	0	0	0	0	0	0	0	0	0	0	0	0	0

Bit(s)	Name	Description
31:0	UNMASK_FAIL_INTSTS	This field is the bit-map of unmask fail interrupt status of each channel. The unmask fail interrupt will assert when HW detect the CH_MASK field of NEXT_CH2UNMASK channel is 1'b0 while trying to clear it.

10002A04 GDMA_DONE_INTSTS Segment Done Interrupt Status 00000000

Bit	31	30	29	28	27	26	25	24	23	22	21	20	19	18	17	16
Name	SEGMENT_DONE_INTSTS[31:16]															
Type	W1C															
Reset	0	0	0	0	0	0	0	0	0	0	0	0	0	0	0	0
Bit	15	14	13	12	11	10	9	8	7	6	5	4	3	2	1	0
Name	SEGMENT_DONE_INTSTS[15:0]															
Type	W1C															

Reset	0	0	0	0	0	0	0	0	0	0	0	0	0	0	0	0	0
--------------	---	---	---	---	---	---	---	---	---	---	---	---	---	---	---	---	---

Bit(s)	Name	Description
31:0	SEGMENT_DONE_INTSTS	This field is the bit-map of segment done interrupt status of each channel. The segment done interrupt will assert when each segment is transferred completely.

10002A20 **GDMA_GCT** **Global Control** **0000000E**

Bit	31	30	29	28	27	26	25	24	23	22	21	20	19	18	17	16
Name	RESERVED[26:11]															
Type	RO															
Reset	0	0	0	0	0	0	0	0	0	0	0	0	0	0	0	0
Bit	15	14	13	12	11	10	9	8	7	6	5	4	3	2	1	0
Name	RESERVED[10:0]											TOTAL_CH_NUM	IP_VER	ARB_MODE		
Type	RO											RO	RO	RW		
Reset	0	0	0	0	0	0	0	0	0	0	0	0	1	1	1	0

Bit(s)	Name	Description
4:3	TOTAL_CH_NUM	Total channel number supported 0: 8 channels 1: 16 channels 2: 32 channels 3: Undefined
2:1	IP_VER	GDMA core version
0	ARB_MODE	Arbitration mode selection 0: channel 0 has highest priority and others are round-robin 1: All channel are round-robin

10002A30 **GDMA_PERI_ADDR_START_0** **Peripheral Region 0 Starting Address** **10000000**

Bit	31	30	29	28	27	26	25	24	23	22	21	20	19	18	17	16
Name	PERI_ADDR_START_0[31:16]															
Type	RW															
Reset	0	0	0	1	0	0	0	0	0	0	0	0	0	0	0	0
Bit	15	14	13	12	11	10	9	8	7	6	5	4	3	2	1	0
Name	PERI_ADDR_START_0[15:0]															
Type	RW															
Reset	0	0	0	0	0	0	0	0	0	0	0	0	0	0	0	0

Bit(s)	Name	Description
31:0	PERI_ADDR_START_0	GDMA request will direct to peripheral bus if the request address >= PERI_ADDR_START_x & < PERI_ADDR_END_x

10002A34 **GDMA_PERI_ADDR_END_0** **Peripheral Region 0 End Address** **20000000**

Bit	31	30	29	28	27	26	25	24	23	22	21	20	19	18	17	16
Name	PERI_ADDR_END_0[31:16]															
Type	RW															
Reset	0	0	1	0	0	0	0	0	0	0	0	0	0	0	0	0
Bit	15	14	13	12	11	10	9	8	7	6	5	4	3	2	1	0
Name	PERI_ADDR_END_0[15:0]															

Type	RW															
Reset	0	0	0	0	0	0	0	0	0	0	0	0	0	0	0	0

Bit(s)	Name	Description
31:0	PERI_ADDR_END_0	GDMA request will direct to peripheral bus if the request address >= PERI_ADDR_START_x & < PERI_ADDR_END_x

10002A38 GDMA PERI ADDR START 1 Peripheral Region 1 Starting Address 2000000
0

Bit	31	30	29	28	27	26	25	24	23	22	21	20	19	18	17	16
Name	PERI_ADDR_START_1[31:16]															
Type	RW															
Reset	0	0	1	0	0	0	0	0	0	0	0	0	0	0	0	0
Bit	15	14	13	12	11	10	9	8	7	6	5	4	3	2	1	0
Name	PERI_ADDR_START_1[15:0]															
Type	RW															
Reset	0	0	0	0	0	0	0	0	0	0	0	0	0	0	0	0

Bit(s)	Name	Description
31:0	PERI_ADDR_START_1	GDMA request will direct to peripheral bus if the request address >= PERI_ADDR_START_x & < PERI_ADDR_END_x

10002A3C GDMA PERI ADDR END 1 Peripheral Region 1 End Address 3000000
0

Bit	31	30	29	28	27	26	25	24	23	22	21	20	19	18	17	16
Name	PERI_ADDR_END_1[31:16]															
Type	RW															
Reset	0	0	1	1	0	0	0	0	0	0	0	0	0	0	0	0
Bit	15	14	13	12	11	10	9	8	7	6	5	4	3	2	1	0
Name	PERI_ADDR_END_1[15:0]															
Type	RW															
Reset	0	0	0	0	0	0	0	0	0	0	0	0	0	0	0	0

Bit(s)	Name	Description
31:0	PERI_ADDR_END_1	GDMA request will direct to peripheral bus if the request address >= PERI_ADDR_START_x & < PERI_ADDR_END_x

10002A40 GDMA PERI ADDR START 2 Peripheral Region 2 Starting Address 1000000
0

Bit	31	30	29	28	27	26	25	24	23	22	21	20	19	18	17	16
Name	PERI_ADDR_START_2[31:16]															
Type	RW															
Reset	0	0	0	1	0	0	0	0	0	0	0	0	0	0	0	0
Bit	15	14	13	12	11	10	9	8	7	6	5	4	3	2	1	0
Name	PERI_ADDR_START_2[15:0]															
Type	RW															
Reset	0	0	0	0	0	0	0	0	0	0	0	0	0	0	0	0

Bit(s)	Name	Description
31:0	PERI_ADDR_START_2	GDMA request will direct to peripheral bus if the request address >= PERI_ADDR_START_x & < PERI_ADDR_END_x

10002A44 GDMA PERI Peripheral Region 2 End Address 2000000
ADDR_END 2 0

Bit	31	30	29	28	27	26	25	24	23	22	21	20	19	18	17	16
Name	PERI_ADDR_END_2[31:16]															
Type	RW															
Reset	0	0	1	0	0	0	0	0	0	0	0	0	0	0	0	0
Bit	15	14	13	12	11	10	9	8	7	6	5	4	3	2	1	0
Name	PERI_ADDR_END_2[15:0]															
Type	RW															
Reset	0	0	0	0	0	0	0	0	0	0	0	0	0	0	0	0

Bit(s)	Name	Description
31:0	PERI_ADDR_END_2	GDMA request will direct to peripheral bus if the request address >= PERI_ADDR_START_x & < PERI_ADDR_END_x

10002A48 GDMA PERI Peripheral Region 3 Starting Address 6000000
ADDR_START 3

Bit	31	30	29	28	27	26	25	24	23	22	21	20	19	18	17	16
Name	PERI_ADDR_START_3[31:16]															
Type	RW															
Reset	0	1	1	0	0	0	0	0	0	0	0	0	0	0	0	0
Bit	15	14	13	12	11	10	9	8	7	6	5	4	3	2	1	0
Name	PERI_ADDR_START_3[15:0]															
Type	RW															
Reset	0	0	0	0	0	0	0	0	0	0	0	0	0	0	0	0

Bit(s)	Name	Description
31:0	PERI_ADDR_START_3	GDMA request will direct to peripheral bus if the request address >= PERI_ADDR_START_x & < PERI_ADDR_END_x

10002A4C GDMA PERI Peripheral Region 3 End Address 7000000
ADDR_END 3 0

Bit	31	30	29	28	27	26	25	24	23	22	21	20	19	18	17	16
Name	PERI_ADDR_END_3[31:16]															
Type	RW															
Reset	0	1	1	1	0	0	0	0	0	0	0	0	0	0	0	0
Bit	15	14	13	12	11	10	9	8	7	6	5	4	3	2	1	0
Name	PERI_ADDR_END_3[15:0]															
Type	RW															
Reset	0	0	0	0	0	0	0	0	0	0	0	0	0	0	0	0

Bit(s)	Name	Description
31:0	PERI_ADDR_END_3	GDMA request will direct to peripheral bus if the request address >= PERI_ADDR_START_x & < PERI_ADDR_END_x

5.16 AES Controller

5.16.1 Registers

AES Changes LOG

Revision	Date	Author	Change Log
0.1	2013/4/30	Morrie Lin	Initialization
0.2	2013/6/5	Morrie Lin	Add desc_5dw_info_en register
0.3	2013/6/7	Morrie Lin	Update AES base address

Module name: AES Base address: (+10004000h)

Address	Name	Width	Register Function
10004000	<u>TX_BASE_PTR0</u>	32	TX_BASE_PTR0 Used for DMA base address of TX ring0
10004004	<u>TX_MAX_CNT0</u>	32	TX_MAX_CNT0 Used for DMA max number of TX ring0
10004008	<u>TX_CTX_IDX0</u>	32	TX_CTX_IDX0 Used for CPU pointer of TX ring0
1000400C	<u>TX_DTX_IDX0</u>	32	TX_DTX_IDX0 Used for DMA pointer of TX ring0
10004100	<u>RX_BASE_PTR0</u>	32	RX_BASE_PTR0 Used for DMA base address of RX ring0
10004104	<u>RX_MAX_CNT0</u>	32	RX_MAX_CNT0 Used for DMA max number of RX ring0
10004108	<u>RX_CALC_IDX0</u>	32	RX_CALC_IDX0 Used for CPU pointer of RX ring0
1000410C	<u>FS_DRX_IDX0</u>	32	FS_DRX_IDX0 Used for DMA pointer of RX ring0
10004200	<u>PDMA_INFO</u>	32	PDMA_INFO used for PDMA information
10004204	<u>PDMA_GLO_CFG</u>	32	PDMA_GLO_CFG used for PDMA setting
10004208	<u>PDMA_RST_IDX</u>	32	PDMA_RST_IDX used for PDMA setting
1000420C	<u>DELAY_INT_CFG</u>	32	DELAY_INT_CFG used for PDMA setting
10004210	<u>PDMA_Q_CFG</u>	32	PDMA_Q_CFG used for PDMA setting
10004220	<u>PDMA_INT_STA</u>	32	PDMA_INT_STA used for PDMA setting
10004228	<u>PDMA_INT_MSK</u>	32	PDMA_INT_MSK used for PDMA setting

10004000 TX_BASE_PTR0 TX_BASE_PTR0 00000000

Bit	31	30	29	28	27	26	25	24	23	22	21	20	19	18	17	16
Name	RESV															
Type	RO															
Reset	0	0	0	0	0	0	0	0	0	0	0	0	0	0	0	0
Bit	15	14	13	12	11	10	9	8	7	6	5	4	3	2	1	0
Name	TX_BASE_PTR0															
Type	RW															
Reset	0	0	0	0	0	0	0	0	0	0	0	0	0	0	0	0

Bit(s)	Name	Description
31:16	RESV	Reserved
15:0	TX_BASE_PTR0	Tx Base Pointer 0 Points to the base address of TX_Ring 0 (If enable desc_5dw_info_en 8-DWORD aligned address, else 4-DWORD aligned address).

10004004 **TX_MAX_CNT** **TX_MAX_CNT0** **0000000**
 0 **0**

Bit	31	30	29	28	27	26	25	24	23	22	21	20	19	18	17	16
Name	RESV															
Type	RO															
Reset	0	0	0	0	0	0	0	0	0	0	0	0	0	0	0	0
Bit	15	14	13	12	11	10	9	8	7	6	5	4	3	2	1	0
Name	TX_MAX_CNT0															
Type	RW															
Reset	0	0	0	0	0	0	0	0	0	0	0	0	0	0	0	0

Bit(s)	Name	Description
31:16	RESV	Reserved
15:0	TX_MAX_CNT0	Tx Maximum TXD Count 0 The maximum TXD count in TXD_Ring 0.

10004008 **TX_CTX_IDX0** **TX_CTX_IDX0** **0000000**
 0

Bit	31	30	29	28	27	26	25	24	23	22	21	20	19	18	17	16
Name	RESV															
Type	RO															
Reset	0	0	0	0	0	0	0	0	0	0	0	0	0	0	0	0
Bit	15	14	13	12	11	10	9	8	7	6	5	4	3	2	1	0
Name	TX_MAX_CNT0															
Type	RW															
Reset	0	0	0	0	0	0	0	0	0	0	0	0	0	0	0	0

Bit(s)	Name	Description
31:16	RESV	Reserved
15:0	TX_MAX_CNT0	Tx CPU TXD Index n Points to the next TXD to be used by the CPU. (If enable desc_5dw_info_en, 8-DWORD aligned address, else 4-DWORD aligned address).

1000400C **TX_DTX_IDX0** **TX_DTX_IDX0** **0000000**
 0

Bit	31	30	29	28	27	26	25	24	23	22	21	20	19	18	17	16
Name	RESV[23:8]															
Type	RO															
Reset	0	0	0	0	0	0	0	0	0	0	0	0	0	0	0	0
Bit	15	14	13	12	11	10	9	8	7	6	5	4	3	2	1	0
Name	RESV[7:0]								TX_DTX_IDX0							
Type	RO								RO							
Reset	0	0	0	0	0	0	0	0	0	0	0	0	0	0	0	0

Bit(s)	Name	Description
--------	------	-------------

Bit(s)	Name	Description
31:8	RESV	Reserved
7:0	TX_DTX_IDX0	Tx DMA TXD Index n Points to the next TXD to be used by the DMA. (If enable desc_5dw_info_en, 8-DWORD aligned address, else 4-DWORD aligned address).

10004100 RX_BASE_PT RX_BASE_PTR0 0000000
R0 0

Bit	31	30	29	28	27	26	25	24	23	22	21	20	19	18	17	16
Name	RESV															
Type	RO															
Reset	0	0	0	0	0	0	0	0	0	0	0	0	0	0	0	0
Bit	15	14	13	12	11	10	9	8	7	6	5	4	3	2	1	0
Name	RX_BASE_PTR0															
Type	RW															
Reset	0	0	0	0	0	0	0	0	0	0	0	0	0	0	0	0

Bit(s)	Name	Description
31:16	RESV	Reserved
15:0	RX_BASE_PTR0	Rx Base Pointer 0 Points to the base address of RXD Ring 0 (If enable desc_5dw_info_en, 8-DWORD aligned address, else 4-DWORD aligned address).

10004104 RX_MAX_CNT RX_MAX_CNT0 0000000
0 0

Bit	31	30	29	28	27	26	25	24	23	22	21	20	19	18	17	16
Name	RESV															
Type	RO															
Reset	0	0	0	0	0	0	0	0	0	0	0	0	0	0	0	0
Bit	15	14	13	12	11	10	9	8	7	6	5	4	3	2	1	0
Name	RX_MAX_CNT0															
Type	RW															
Reset	0	0	0	0	0	0	0	0	0	0	0	0	0	0	0	0

Bit(s)	Name	Description
31:16	RESV	Reserved
15:0	RX_MAX_CNT0	Rx Maximum Count 0 The maximum RXD count in RXD Ring 0.

10004108 RX_CALC_ID RX_CALC_IDX0 0000000
X0 0

Bit	31	30	29	28	27	26	25	24	23	22	21	20	19	18	17	16
Name	RESV															
Type	RO															
Reset	0	0	0	0	0	0	0	0	0	0	0	0	0	0	0	0
Bit	15	14	13	12	11	10	9	8	7	6	5	4	3	2	1	0
Name	RX_CALI_IDX0															
Type	RW															
Reset	0	0	0	0	0	0	0	0	0	0	0	0	0	0	0	0

Bit(s)	Name	Description
31:16	RESV	Reserved

Bit(s)	Name	Description
15:0	RX_CALI_IDX0	Rx CPU RXD Index 0 Points to the next RXD the CPU will allocate to RXD Ring 0. (If enable desc_5dw_info_en, 8-DWORD aligned address, else 4-DWORD aligned address).

1000410C FS_DRX_IDX0 FS_DRX_IDX0 0000000
0

Bit	31	30	29	28	27	26	25	24	23	22	21	20	19	18	17	16
Name	RESV[23:8]															
Type	RO															
Reset	0	0	0	0	0	0	0	0	0	0	0	0	0	0	0	0
Bit	15	14	13	12	11	10	9	8	7	6	5	4	3	2	1	0
Name	RESV[7:0]								RX_DRX_IDX0							
Type	RO								RO							
Reset	0	0	0	0	0	0	0	0	0	0	0	0	0	0	0	0

Bit(s)	Name	Description
31:8	RESV	Reserved
7:0	RX_DRX_IDX0	Rx DMA RXD Index n Points to the next RXD that the DMA will use in FDS Ring 0. (If enable desc_5dw_info_en, 8-DWORD aligned address, else 4-DWORD aligned address).

10004200 PDMA_INFO PDMA_INFO 4C00010
1

Bit	31	30	29	28	27	26	25	24	23	22	21	20	19	18	17	16
Name	VERSION				INDEX_WIDTH				BASE_PTR_WIDTH							
Type	RO				RO				RO							
Reset	0	1	0	0	1	1	0	0	0	0	0	0	0	0	0	0
Bit	15	14	13	12	11	10	9	8	7	6	5	4	3	2	1	0
Name	RX_RING_NUM								TX_RING_NUM							
Type	RO								RO							
Reset	0	0	0	0	0	0	0	1	0	0	0	0	0	0	0	1

Bit(s)	Name	Description
31:28	VERSION	PDMA controller version.
27:24	INDEX_WIDTH	RX Ring index width
23:16	BASE_PTR_WIDTH	Base Pointer Width
15:8	RX_RING_NUM	Rx ring number
7:0	TX_RING_NUM	Tx ring number

10004204 PDMA_GLO_CFG PDMA_GLO_CFG 0000045
0

Bit	31	30	29	28	27	26	25	24	23	22	21	20	19	18	17	16
Name	RX_2B_OF_FSET	CL_KG_AT_E_BYP	BY_TE_SW_AP	RESV[16:4]												
Type	RW	RO	RO	RO												
Reset	0	0	0	0	0	0	0	0	0	0	0	0	0	0	0	0
Bit	15	14	13	12	11	10	9	8	7	6	5	4	3	2	1	0
Name	RESV[3:0]				des_c_5dw_	mul_ti_dma	sha_re_fifo_	des_c_32b_	BIG_EN_DIA	TX_WB_D	WPDMA_B_T_SIZE	RX_DM_A	RX_DM_A_E	TX_DM_A	TX_DM_A_E	

					info_en	_en	en	en	N	DO NE			BU SY	N	BU SY	N
Type	RO				RW	RW	RW	RW	RW	RW	RW		RO	RW	RO	RW
Reset	0	0	0	0	0	1	0	0	0	1	0	1	0	0	0	0

Bit(s)	Name	Description
31	RX_2B_OFFSET	Rx 2 Byte Offset Sets the byte size of the Rx buffer offset. 0: 4 bytes 1: 2 bytes. 0
30	CLKGATE_BYP	Clock Gating Control Status Register Controls gating of the PDMA clock. 0: PDMA clock operates in freerun mode. 1: PDMA clock is gated when idle.
29	BYTE_SWAP	Byte Swap The DMA applies the endian rule to convert the descriptor. 0: Byte swap not applied. 1: Apply byte swap.
28:12	RESV	Reserved
11	desc_5dw_info_en	Support extension tx_info/rx_info to to 20 byte and the total length of descriptor is 32 byte. 0: Disable 1: Enable
10	multi_dma_en	
9	share_fifo_en	
8	desc_32b_en	Support 32 Byte alignment descriptor Enables support for 32 Byte alignment PDMA descriptors. 0: Disable 1: Enable
7	BIG_ENDIAN	Selects the Endian mode for the SoC platform section. DMA applies the endian rule to convert payload and Tx/Rx information. DMA does not apply the endian rule to registers or descriptors. 0: Little endian 1: Big endian
6	TX_WB_DDONE	Tx Write Back DDONE Enables TX_DMA writing back DDONE into TXD. 0: Disable 1: Enable
5:4	WPDMA_BT_SIZE	PDMA Burst Size Defines the burst size of PDMA. 0 : 4 DWORD (16bytes). 1 : 8 DWORD (32 bytes). 2 : 16 DWORD (64 bytes). 3 : 32 DWORD (128 bytes)
3	RX_DMA_BUSY	1 : RX_DMA is busy. 0 : RX_DMA is not busy
2	RX_DMA_EN	Rx DMA Enable Enables Rx DMA. When disabled, Rx DMA finishes the current receiving packet, and then stops. 0: Disable 1: Enable
1	TX_DMA_BUSY	Indicates whether Tx DMA is busy. 0: Not busy 1: Busy
0	TX_DMA_EN	Tx DMA Enable Enables Tx DMA. When disabled, Tx DMA finishes the current sending packet, and then stops. 0: Disable 1: Enable

10004208 PDMA_RST_I PDMA_RST_IDX 0000000
DX 0

Bit	31	30	29	28	27	26	25	24	23	22	21	20	19	18	17	16
Name	RESV[31:16]															
Type	RO															
Reset	0	0	0	0	0	0	0	0	0	0	0	0	0	0	0	0
Bit	15	14	13	12	11	10	9	8	7	6	5	4	3	2	1	0
Name	RESV[15:0]															
Type	RO															
Reset	0	0	0	0	0	0	0	0	0	0	0	0	0	0	0	0

Bit(s)	Name	Description
31:0	RESV	Reserved

1000420C DELAY_INT_C DELAY_INT_CFG 0000000
FG 0

Bit	31	30	29	28	27	26	25	24	23	22	21	20	19	18	17	16
Name	TX DL Y_I NT_ EN	TXMAX_PINT							TXMAX_PTIME							
Type	RW	RW							RW							
Reset	0	0	0	0	0	0	0	0	0	0	0	0	0	0	0	0
Bit	15	14	13	12	11	10	9	8	7	6	5	4	3	2	1	0
Name	RX DL Y_I NT_ EN	RXMAX_PINT							RXMAX_PTIME							
Type	RW	RW							RW							
Reset	0	0	0	0	0	0	0	0	0	0	0	0	0	0	0	0

Bit(s)	Name	Description
31	TXDLY_INT_EN	Tx Delay Interrupt Enable Enables the Tx delayed interrupt mechanism. 0: Disable 1: Enable
30:24	TXMAX_PINT	Tx Maximum Pending Interrupts Specifies the maximum number of pending interrupts. When the number of pending interrupts is equal to or greater than the value specified here or the interrupt pending time has reached the limit (see below), a final TX_DLY_INT is generated. 0: Disable this feature.
23:16	TXMAX_PTIME	Tx Maximum Pending Time Specifies the maximum pending time for the internal TX_DONE_INT0 and TX_DONE_INT1. When the pending time is equal to or greater than TXMAX_PTIME x 20us or the number of pended TX_DONE_INT0 and TX_DONE_INT1 is equal to or greater than TXMAX_PINT (see above), a final TX_DLY_INT is generated 0: Disable this feature.
15	RXDLY_INT_EN	Rx Delay Interrupt Enable Enables the Rx delayed interrupt mechanism. 0: Disable 1: Enable
14:8	RXMAX_PINT	Rx Maximum Pending Interrupts Specifies the maximum number of pending interrupts. When the number of pended interrupts is equal to or greater than the value specified here or the interrupt pending time has reached the limit (see below), a final RX_DLY_INT is generated. 0: Disable this feature.

Bit(s)	Name	Description
7:0	RXMAX_PTIME	Rx Maximum Pending Time Specifies the maximum pending time for the internal RX_DONE_INT. When the pending time is equal to or greater than RXMAX_PTIME x 20 us, or the number of pended RX_DONE_INT is equal to or greater than RXMAX_PCNT (see above), a final RX_DLY_INT is generated. 0: Disable this feature.

10004210 PDMA_Q_CFG PDMA_Q_CFG 0000000
G 0

Bit	31	30	29	28	27	26	25	24	23	22	21	20	19	18	17	16
Name	RESV[27:12]															
Type	RO															
Reset	0	0	0	0	0	0	0	0	0	0	0	0	0	0	0	0
Bit	15	14	13	12	11	10	9	8	7	6	5	4	3	2	1	0
Name	RESV[11:0]											RST_DRX_IDX1				
Type	RO											RW				
Reset	0	0	0	0	0	0	0	0	0	0	0	0	0	0	0	0

Bit(s)	Name	Description
31:4	RESV	
3:0	RST_DRX_IDX1	Will stop to block interface as RX-descriptors reach this threshold

10004220 PDMA_INT_STA PDMA_INT_STA 0000000
TA 0

Bit	31	30	29	28	27	26	25	24	23	22	21	20	19	18	17	16
Name	RX_COHERENT	RX_DLY_INT	TX_COHERENT	TX_DLY_INT	RESV1											RX_DONE_INT
Type	RW	RW	RW	RW	RO											RW
Reset	0	0	0	0	0	0	0	0	0	0	0	0	0	0	0	0
Bit	15	14	13	12	11	10	9	8	7	6	5	4	3	2	1	0
Name	RESV															TX_DONE_INT
Type	RO															RW
Reset	0	0	0	0	0	0	0	0	0	0	0	0	0	0	0	0

Bit(s)	Name	Description
31	RX_COHERENT	Rx Coherent Interrupt Asserts when the Rx DMA is ready to handle a queue, but cannot access the queue because the driver is not ready.
30	RX_DLY_INT	Rx Delay Interrupt Asserts when the number of pended Rx interrupts has reached a specified level, or when the pending time is reached. Configure this interrupt using the DELAY_INT_CFG register.
29	TX_COHERENT	Tx Coherent Interrupt Asserts when the Tx DMA is ready to handle a queue, but cannot access the queue because the driver is not ready.
28	TX_DLY_INT	Tx Delay Interrupt Asserts when the number of pended Tx interrupts has reached a specified level, or when the pending time is reached. Configure this interrupt using the DELAY_INT_CFG register.
27:17	RESV1	
16	RX_DONE_INT	Rx Queue 0 Done Interrupt

Bit(s)	Name	Description
15:1	RESV	Asserts when an Rx packet is received on Queue 0.
0	TX_DONE_INT	Tx Queue 0 Done Interrupt Asserts when a Tx Queue 0 packet is transmitted.

10004228 PDMA_INT_MSK PDMA_INT_MSK 0000000
0

Bit	31	30	29	28	27	26	25	24	23	22	21	20	19	18	17	16
Name	RX_COHERENT_EN	RX_DLY_INT_EN	TX_COHERENT_INT_EN	TX_DLY_INT_EN	RESV1											RX_DONE_INT_EN
Type	RW	RW	RW	RW	RO											RW
Reset	0	0	0	0	0	0	0	0	0	0	0	0	0	0	0	0
Bit	15	14	13	12	11	10	9	8	7	6	5	4	3	2	1	0
Name	RESV															TX_DONE_INT_EN
Type	RO															RW
Reset	0	0	0	0	0	0	0	0	0	0	0	0	0	0	0	0

Bit(s)	Name	Description
31	RX_COHERENT_EN	Masks the Rx Coherent interrupt. This interrupt asserts when the Rx DMA is ready to handle a queue, but cannot access the queue because the driver is not ready.
30	RX_DLY_INT_EN	Masks the Rx Delay interrupt. This interrupt asserts when the number of pending Rx interrupts has reached a specified level, or when the pending time is reached.
29	TX_COHERENT_INT_EN	Masks the Tx Coherent interrupt. This interrupt asserts when the Tx DMA is ready to handle a queue, but cannot access the queue because the driver is not ready.
28	TX_DLY_INT_EN	Masks the Tx Delay interrupt. This interrupt asserts when the number of pending Tx interrupts has reached a specified level, or when the pending time is reached.
27:17	RESV1	
16	RX_DONE_INT_EN	Masks the Rx Queue 0 Done interrupt. This interrupt asserts when an Rx packet is received on Queue 0.
15:1	RESV	
0	TX_DONE_INT_EN	Masks the Tx Queue 0 Done interrupt. This interrupt asserts when a Tx packet is transmitted on Queue 0.

5.17 PWM (Pulse Width Modulation)

5.17.1 Registers

PWM Changes LOG

Revision	Date	Author	Change Log
1	2013/11/26	Rick Ho	Initial Version

Module name: PWM Base address: (+10005000h)

Address	Name	Width	Register Function
10005000	<u>PWM_ENABLE</u>	32	PWM Enable register
10005010	<u>PWM0_CON</u>	32	PWM0 Control register
10005014	<u>PWM0_HDURATION</u>	32	PWM0 High Duration register
10005018	<u>PWM0_LDURATION</u>	32	PWM0 Low Duration register
1000501C	<u>PWM0_GDURATION</u>	32	PWM0 Guard Duration register
10005030	<u>PWM0_SEND_DATA0</u>	32	PWM0 Send Data0 register
10005034	<u>PWM0_SEND_DATA1</u>	32	PWM0 Send Data1 register
10005038	<u>PWM0_WAVE_NUM</u>	32	PWM0 Wave Number register
1000503C	<u>PWM0_DATA_WIDTH</u>	32	PWM0 Data Width register
10005040	<u>PWM0_THRESHOLD</u>	32	PWM0 Thresh register
10005044	<u>PWM0_SEND_WAVENUM</u>	32	PWM0 Send Wave Number register
10005050	<u>PWM1_CON</u>	32	PWM1 Control register
10005054	<u>PWM1_HDURATION</u>	32	PWM1 High Duration register
10005058	<u>PWM1_LDURATION</u>	32	PWM1 Low Duration register
1000505C	<u>PWM1_GDURATION</u>	32	PWM1 Guard Duration register
10005070	<u>PWM1_SEND_DATA0</u>	32	PWM1 Send Data0 register
10005074	<u>PWM1_SEND_DATA1</u>	32	PWM1 Send Data1 register
10005078	<u>PWM1_WAVE_NUM</u>	32	PWM1 Wave Number register
1000507C	<u>PWM1_DATA_WIDTH</u>	32	PWM1 Data Width register
10005080	<u>PWM1_THRESHOLD</u>	32	PWM1 Thresh register
10005084	<u>PWM1_SEND_WAVENUM</u>	32	PWM1 Send Wave Number register
10005090	<u>PWM2_CON</u>	32	PWM2 Control register
10005094	<u>PWM2_HDURATION</u>	32	PWM2 High Duration register
10005098	<u>PWM2_LDURATION</u>	32	PWM2 Low Duration register
1000509C	<u>PWM2_GDURATION</u>	32	PWM2 Guard Duration register

100050B0	<u>PWM2_SEND_DATA0</u>	32	PWM2 Send Data0 register
100050B4	<u>PWM2_SEND_DATA1</u>	32	PWM2 Send Data1 register
100050B8	<u>PWM2_WAVE_NUM</u>	32	PWM2 Wave Number register
100050BC	<u>PWM2_DATA_WIDTH</u>	32	PWM2 Data Width register
100050C0	<u>PWM2_THRESH</u>	32	PWM2 Thresh register
100050C4	<u>PWM2_SEND_WAVENUM</u>	32	PWM2 Send Wave Number register
100050D0	<u>PWM3_CON</u>	32	PWM3 Control register
100050D4	<u>PWM3_HDURATION</u>	32	PWM3 High Duration register
100050D8	<u>PWM3_LDURATION</u>	32	PWM3 Low Duration register
100050DC	<u>PWM3_GDURATION</u>	32	PWM3 Guard Duration register
100050F0	<u>PWM3_SEND_DATA0</u>	32	PWM3 Send Data0 register
100050F4	<u>PWM3_SEND_DATA1</u>	32	PWM3 Send Data1 register
100050F8	<u>PWM3_WAVE_NUM</u>	32	PWM3 Wave Number register
100050FC	<u>PWM3_DATA_WIDTH</u>	32	PWM3 Data Width register
10005100	<u>PWM3_THRESH</u>	32	PWM3 Thresh register
10005104	<u>PWM3_SEND_WAVENUM</u>	32	PWM3 Send Wave Number register
1000520C	<u>PWM_EN_STATUS</u>	32	PWM Enable Status register

10005000 PWM_ENABLE PWM Enable register 00000000

Bit	31	30	29	28	27	26	25	24	23	22	21	20	19	18	17	16
Name	RESV[27:12]															
Type	RO															
Reset	0	0	0	0	0	0	0	0	0	0	0	0	0	0	0	0
Bit	15	14	13	12	11	10	9	8	7	6	5	4	3	2	1	0
Name	RESV[11:0]												PWM3_EN	PWM2_EN	PWM1_EN	PWM0_EN
Type	RO												RW	RW	RW	RW
Reset	0	0	0	0	0	0	0	0	0	0	0	0	0	0	0	0

Bit(s)	Name	Description
31:4	RESV	RESERVED
3	PWM3_EN	0: disabe PWM3 1: enable PWM3
2	PWM2_EN	0: disabe PWM2 1: enable PWM2
1	PWM1_EN	0: disabe PWM1 1: enable PWM1
0	PWM0_EN	0: disabe PWM0 1: enable PWM0

10005010 PWM0_CON PWM0 Control register

00007E0
0

Bit	31	30	29	28	27	26	25	24	23	22	21	20	19	18	17	16
Name	RESV0															
Type	RO															
Reset	0	0	0	0	0	0	0	0	0	0	0	0	0	0	0	0
Bit	15	14	13	12	11	10	9	8	7	6	5	4	3	2	1	0
Name	OLD_PWM_MODE	STOP_BITPOS						GUARD_VALUE	IDLE_VALUE	RESV1			CLKSEL	CLKDIV		
Type	RW	RW						RW	RW	RO			RW	RW		
Reset	0	1	1	1	1	1	1	0	0	0	0	0	0	0	0	0

Bit(s)	Name	Description
31:16	RESV0	RESERVED
15	OLD_PWM_MODE	0: New PWM mode 1: Old PWM mode
14:9	STOP_BITPOS	The stop bit position for source data in periodical mode. In FIFO mode, it's used to indicate the stop bit position in total 64 bits. In Memory mode, it's for the stop bit position in the last 32 bits.
8	GUARD_VALUE	PWM0 output value when guard time.
7	IDLE_VALUE	PWM0 output value when idle state.
6:4	RESV1	RESERVED
3	CLKSEL	Select PWM0 clock 0: CLK= 100KHz 1: CLK= 40MHz
2:0	CLKDIV	Select PWM0 clock scale. 000: CLK Hz 001: CLK/2 Hz 010: CLK/4 Hz 011: CLK/8 Hz 100: CLK/16 Hz 101: CLK/32 Hz 110: CLK/64 Hz 111: CLK/128 Hz

10005014 PWM0_HDURATION PWM0 High Duration register

0000000
1

Bit	31	30	29	28	27	26	25	24	23	22	21	20	19	18	17	16
Name	RESV															
Type	RO															
Reset	0	0	0	0	0	0	0	0	0	0	0	0	0	0	0	0
Bit	15	14	13	12	11	10	9	8	7	6	5	4	3	2	1	0
Name	HDURATION															
Type	RW															
Reset	0	0	0	0	0	0	0	0	0	0	0	0	0	0	0	1

Bit(s)	Name	Description
31:16	RESV	RESERVED
15:0	HDURATION	PWM0 pulse duration based on the current clock when PWM output is high. If duration =N, need to program N-1 in this register. Note: The duration of PWM must not be 0.

10005018 PWM0_LDUR PWM0 Low Duration register

0000000

ATION

1

Bit	31	30	29	28	27	26	25	24	23	22	21	20	19	18	17	16
Name	RESV															
Type	RO															
Reset	0	0	0	0	0	0	0	0	0	0	0	0	0	0	0	0
Bit	15	14	13	12	11	10	9	8	7	6	5	4	3	2	1	0
Name	LDURATION															
Type	RW															
Reset	0	0	0	0	0	0	0	0	0	0	0	0	0	0	0	1

Bit(s)	Name	Description
31:16	RESV	RESERVED
15:0	LDURATION	PWM0 pulse duration based on the current clock when PWM output is low. If duration =N, need to program N-1 in this register. Note: The duration of PWM must not be 0.

1000501C PWM0_GDUR PWM0 Guard Duration register **0000000**
ATION **0**

Bit	31	30	29	28	27	26	25	24	23	22	21	20	19	18	17	16
Name	RESV															
Type	RO															
Reset	0	0	0	0	0	0	0	0	0	0	0	0	0	0	0	0
Bit	15	14	13	12	11	10	9	8	7	6	5	4	3	2	1	0
Name	GUARD_DURATION															
Type	RW															
Reset	0	0	0	0	0	0	0	0	0	0	0	0	0	0	0	0

Bit(s)	Name	Description
31:16	RESV	RESERVED
15:0	GUARD_DURATION	

10005030 PWM0_SEND PWM0 Send Data0 register **0000000**
DATA0 **0**

Bit	31	30	29	28	27	26	25	24	23	22	21	20	19	18	17	16
Name	SEND_DATA0[31:16]															
Type	RW															
Reset	0	0	0	0	0	0	0	0	0	0	0	0	0	0	0	0
Bit	15	14	13	12	11	10	9	8	7	6	5	4	3	2	1	0
Name	SEND_DATA0[15:0]															
Type	RW															
Reset	0	0	0	0	0	0	0	0	0	0	0	0	0	0	0	0

Bit(s)	Name	Description
31:0	SEND_DATA0	PWM0 local buffer0 of pulse sequence data to be generated. Note: This value should be written only in periodically FIFO mode. In other mode, this buffer is for internal memory access.

10005034 PWM0_SEND PWM0 Send Data1 register **0000000**
DATA1 **0**

Bit	31	30	29	28	27	26	25	24	23	22	21	20	19	18	17	16
Name	SEND_DATA1[31:16]															
Type	RW															
Reset	0	0	0	0	0	0	0	0	0	0	0	0	0	0	0	0
Bit	15	14	13	12	11	10	9	8	7	6	5	4	3	2	1	0
Name	SEND_DATA1[15:0]															

Type	RW															
Reset	0	0	0	0	0	0	0	0	0	0	0	0	0	0	0	0

Bit(s)	Name	Description
31:0	SEND_DATA1	PWM0 local buffer0 of pulse sequence data to be generated. Note: This value should be written only in periodically FIFO mode. In other mode, this buffer is for internal memory access.

10005038 PWM0_WAVE_NUM **PWM0 Wave Number register** **0000000**
0

Bit	31	30	29	28	27	26	25	24	23	22	21	20	19	18	17	16
Name	RESV															
Type	RO															
Reset	0	0	0	0	0	0	0	0	0	0	0	0	0	0	0	0
Bit	15	14	13	12	11	10	9	8	7	6	5	4	3	2	1	0
Name	WAVE_NUM															
Type	RW															
Reset	0	0	0	0	0	0	0	0	0	0	0	0	0	0	0	0

Bit(s)	Name	Description
31:16	RESV	RESERVED
15:0	WAVE_NUM	The number by which PWM0 will generate from the pulse data repeatedly. Note: If WAVE_NUM=0, the waveform generation will not stop until it is disabled.

1000503C PWM0_DATA_WIDTH **PWM0 Data Width register** **0000000**
0

Bit	31	30	29	28	27	26	25	24	23	22	21	20	19	18	17	16
Name	RESV[18:3]															
Type	RO															
Reset	0	0	0	0	0	0	0	0	0	0	0	0	0	0	0	0
Bit	15	14	13	12	11	10	9	8	7	6	5	4	3	2	1	0
Name	RESV[2:0]			DATA_WIDTH												
Type	RO			RW												
Reset	0	0	0	0	0	0	0	0	0	0	0	0	0	0	0	0

Bit(s)	Name	Description
31:13	RESV	RESERVED
12:0	DATA_WIDTH	The PWM0 pulse data width in the old PWM mode.

10005040 PWM0_THRE_SH **PWM0 Thresh register** **0000000**
0

Bit	31	30	29	28	27	26	25	24	23	22	21	20	19	18	17	16
Name	RESV[18:3]															
Type	RO															
Reset	0	0	0	0	0	0	0	0	0	0	0	0	0	0	0	0
Bit	15	14	13	12	11	10	9	8	7	6	5	4	3	2	1	0
Name	RESV[2:0]			THRESH												
Type	RO			RW												
Reset	0	0	0	0	0	0	0	0	0	0	0	0	0	0	0	0

Bit(s)	Name	Description
31:13	RESV	RESERVED
12:0	THRESH	The PWM0 pulse data high/low switching threshold in the old PWM

Bit(s)	Name	Description
		mode.

10005044 PWM0_SEND WAVENUM PWM0 Send Wave Number register 0000000
0

Bit	31	30	29	28	27	26	25	24	23	22	21	20	19	18	17	16
Name	RESV															
Type	RO															
Reset	0	0	0	0	0	0	0	0	0	0	0	0	0	0	0	0
Bit	15	14	13	12	11	10	9	8	7	6	5	4	3	2	1	0
Name	SEND_WAVENUM															
Type	RO															
Reset	0	0	0	0	0	0	0	0	0	0	0	0	0	0	0	0

Bit(s)	Name	Description
31:16	RESV	RESERVED
15:0	SEND_WAVENUM	The number by which PWM0 has already generated from the specified data source in the periodical mode.

10005050 PWM1_CON PWM1 Control register 00007E0
0

Bit	31	30	29	28	27	26	25	24	23	22	21	20	19	18	17	16
Name	RESV0															
Type	RO															
Reset	0	0	0	0	0	0	0	0	0	0	0	0	0	0	0	0
Bit	15	14	13	12	11	10	9	8	7	6	5	4	3	2	1	0
Name	OLD_PWM_MODE	STOP_BITPOS						GUARD_VALUE	IDLE_VALUE	RESV1				CLKSEL	CLKDIV	
Type	RW	RW						RW	RW	RO				RW	RW	
Reset	0	1	1	1	1	1	1	0	0	0	0	0	0	0	0	0

Bit(s)	Name	Description
31:16	RESV0	RESERVED
15	OLD_PWM_MODE	Use old PWM mode Note: Using old PWM mode also means periodical mode. So SRCSEL and MODE is ignored in this situation. Only old PWM mode with 32 KHz clock source (however could not work in the system sleep-mode). 0: New PWM mode 1: Old PWM mode
14:9	STOP_BITPOS	Note: Using old PWM mode also means periodical mode. So SRCSEL and MODE is ignored in this situation. Only old PWM mode with 32 KHz clock source (however could not work in the system sleep-mode).
8	GUARD_VALUE	PWM1 output value when guard time.
7	IDLE_VALUE	PWM1 output value when idle state.
6:4	RESV1	Select Random Generator mode
3	CLKSEL	Select PWM1 clock 0: CLK= 100KHz 1: CLK= 40MHz
2:0	CLKDIV	Select PWM1 clock scale. 000: CLK Hz 001: CLK/2 Hz 010: CLK/4 Hz 011: CLK/8 Hz 100: CLK/16 Hz

Bit(s)	Name	Description
		101: CLK/32 Hz 110: CLK/64 Hz 111: CLK/128 Hz

10005054 **PWM1_HDURATION** **PWM1 High Duration register** **00000001**

Bit	31	30	29	28	27	26	25	24	23	22	21	20	19	18	17	16
Name	RESV															
Type	RO															
Reset	0	0	0	0	0	0	0	0	0	0	0	0	0	0	0	0
Bit	15	14	13	12	11	10	9	8	7	6	5	4	3	2	1	0
Name	HDURATION															
Type	RW															
Reset	0	0	0	0	0	0	0	0	0	0	0	0	0	0	0	1

Bit(s)	Name	Description
31:16	RESV	RESERVED
15:0	HDURATION	PWM1 pulse duration based on the current clock when PWM output is high. If duration =N, need to program N-1 in this register. Note: The duration of PWM must not be 0.

10005058 **PWM1_LDURATION** **PWM1 Low Duration register** **00000001**

Bit	31	30	29	28	27	26	25	24	23	22	21	20	19	18	17	16
Name	RESV															
Type	RO															
Reset	0	0	0	0	0	0	0	0	0	0	0	0	0	0	0	0
Bit	15	14	13	12	11	10	9	8	7	6	5	4	3	2	1	0
Name	LDURATION															
Type	RW															
Reset	0	0	0	0	0	0	0	0	0	0	0	0	0	0	0	1

Bit(s)	Name	Description
31:16	RESV	RESERVED
15:0	LDURATION	PWM1 pulse duration based on the current clock when PWM output is low. If duration =N, need to program N-1 in this register. Note: The duration of PWM must not be 0.

1000505C **PWM1_GDURATION** **PWM1 Guard Duration register** **00000000**

Bit	31	30	29	28	27	26	25	24	23	22	21	20	19	18	17	16
Name	RESV															
Type	RO															
Reset	0	0	0	0	0	0	0	0	0	0	0	0	0	0	0	0
Bit	15	14	13	12	11	10	9	8	7	6	5	4	3	2	1	0
Name	GUARD_DURATION															
Type	RW															
Reset	0	0	0	0	0	0	0	0	0	0	0	0	0	0	0	0

Bit(s)	Name	Description
31:16	RESV	RESERVED
15:0	GUARD_DURATION	

10005070 PWM1_SEND PWM1 Send Data0 register 0000000
DATA0 0

Bit	31	30	29	28	27	26	25	24	23	22	21	20	19	18	17	16
Name	SEND_DATA0[31:16]															
Type	RW															
Reset	0	0	0	0	0	0	0	0	0	0	0	0	0	0	0	0
Bit	15	14	13	12	11	10	9	8	7	6	5	4	3	2	1	0
Name	SEND_DATA0[15:0]															
Type	RW															
Reset	0	0	0	0	0	0	0	0	0	0	0	0	0	0	0	0

Bit(s)	Name	Description
31:0	SEND_DATA0	PWM1 local buffer0 of pulse sequence data to be generated. Note: This value should be written only in periodically FIFO mode. In other mode, this buffer is for internal memory access.

10005074 PWM1_SEND PWM1 Send Data1 register 0000000
DATA1 0

Bit	31	30	29	28	27	26	25	24	23	22	21	20	19	18	17	16
Name	SEND_DATA1[31:16]															
Type	RW															
Reset	0	0	0	0	0	0	0	0	0	0	0	0	0	0	0	0
Bit	15	14	13	12	11	10	9	8	7	6	5	4	3	2	1	0
Name	SEND_DATA1[15:0]															
Type	RW															
Reset	0	0	0	0	0	0	0	0	0	0	0	0	0	0	0	0

Bit(s)	Name	Description
31:0	SEND_DATA1	PWM1 local buffer0 of pulse sequence data to be generated. Note: This value should be written only in periodically FIFO mode. In other mode, this buffer is for internal memory access.

10005078 PWM1_WAVE PWM1 Wave Number register 0000000
NUM 0

Bit	31	30	29	28	27	26	25	24	23	22	21	20	19	18	17	16
Name	RESV															
Type	RO															
Reset	0	0	0	0	0	0	0	0	0	0	0	0	0	0	0	0
Bit	15	14	13	12	11	10	9	8	7	6	5	4	3	2	1	0
Name	WAVE_NUM															
Type	RW															
Reset	0	0	0	0	0	0	0	0	0	0	0	0	0	0	0	0

Bit(s)	Name	Description
31:16	RESV	RESERVED
15:0	WAVE_NUM	The number by which PWM1 will generate from the pulse data repeatedly. Note: If WAVE_NUM=0, the waveform generation will not stop until it is disabled.

1000507C PWM1_DATA PWM1 Data Width register 0000000
WIDTH 0

Bit	31	30	29	28	27	26	25	24	23	22	21	20	19	18	17	16
Name	RESV[18:3]															

Type	RO															
Reset	0	0	0	0	0	0	0	0	0	0	0	0	0	0	0	0
Bit	15	14	13	12	11	10	9	8	7	6	5	4	3	2	1	0
Name	RESV[2:0]			DATA_WIDTH												
Type	RO			RW												
Reset	0	0	0	0	0	0	0	0	0	0	0	0	0	0	0	0

Bit(s)	Name	Description
31:13	RESV	RESERVED
12:0	DATA_WIDTH	The PWM1 pulse data width in the old PWM mode.

10005080 PWM1_THRE PWM1 Thresh register 0000000
SH 0

Bit	31	30	29	28	27	26	25	24	23	22	21	20	19	18	17	16
Name	RESV[18:3]															
Type	RO															
Reset	0	0	0	0	0	0	0	0	0	0	0	0	0	0	0	0
Bit	15	14	13	12	11	10	9	8	7	6	5	4	3	2	1	0
Name	RESV[2:0]			THRESH												
Type	RO			RW												
Reset	0	0	0	0	0	0	0	0	0	0	0	0	0	0	0	0

Bit(s)	Name	Description
31:13	RESV	RESERVED
12:0	THRESH	The PWM1 pulse data high/low switching threshold in the old PWM mode.

10005084 PWM1_SEND PWM1 Send Wave Number register 0000000
WAVENUM 0

Bit	31	30	29	28	27	26	25	24	23	22	21	20	19	18	17	16
Name	RESV															
Type	RO															
Reset	0	0	0	0	0	0	0	0	0	0	0	0	0	0	0	0
Bit	15	14	13	12	11	10	9	8	7	6	5	4	3	2	1	0
Name	SEND_WAVENUM															
Type	RO															
Reset	0	0	0	0	0	0	0	0	0	0	0	0	0	0	0	0

Bit(s)	Name	Description
31:16	RESV	RESERVED
15:0	SEND_WAVENUM	The number by which PWM1 has already generated from the specified data source in the periodical mode.

10005090 PWM2_CON PWM2 Control register 00007E0
0

Bit	31	30	29	28	27	26	25	24	23	22	21	20	19	18	17	16
Name	RESV0															
Type	RO															
Reset	0	0	0	0	0	0	0	0	0	0	0	0	0	0	0	0
Bit	15	14	13	12	11	10	9	8	7	6	5	4	3	2	1	0
Name	OL D_P WM _M OD E	STOP_BITPOS						GU AR D_V AL UE	IDL E_V AL UE	RESV1				CL KS EL	CLKDIV	
Type	RW	RW						RW	RW	RO				RW	RW	

Reset	0	1	1	1	1	1	1	1	0	0	0	0	0	0	0	0	0
--------------	---	---	---	---	---	---	---	---	---	---	---	---	---	---	---	---	---

Bit(s)	Name	Description
31:16	RESV0	RESERVED
15	OLD_PWM_MODE	Use old PWM mode Note: Using old PWM mode also means periodical mode. So SRCSEL and MODE is ignored in this situation. Only old PWM mode with 32 KHz clock source (however could not work in the system sleep-mode). 0: New PWM mode 1: Old PWM mode
14:9	STOP_BITPOS	Note: Using old PWM mode also means periodical mode. So SRCSEL and MODE is ignored in this situation. Only old PWM mode with 32 KHz clock source (however could not work in the system sleep-mode).
8	GUARD_VALUE	PWM2 output value when guard time.
7	IDLE_VALUE	PWM2 output value when idle state.
6:4	RESV1	Select Random Generator mode
3	CLKSEL	Select PWM2 clock 0: CLK= 100KHz 1: CLK= 40MHz
2:0	CLKDIV	Select PWM2 clock scale. 000: CLK Hz 001: CLK/2 Hz 010: CLK/4 Hz 011: CLK/8 Hz 100: CLK/16 Hz 101: CLK/32 Hz 110: CLK/64 Hz 111: CLK/128 Hz

10005094 **PWM2_HDURATION** **PWM2 High Duration register** **0000000**
1

Bit	31	30	29	28	27	26	25	24	23	22	21	20	19	18	17	16
Name	RESV															
Type	RO															
Reset	0	0	0	0	0	0	0	0	0	0	0	0	0	0	0	0
Bit	15	14	13	12	11	10	9	8	7	6	5	4	3	2	1	0
Name	HDURATION															
Type	RW															
Reset	0	0	0	0	0	0	0	0	0	0	0	0	0	0	0	1

Bit(s)	Name	Description
31:16	RESV	RESERVED
15:0	HDURATION	PWM2 pulse duration based on the current clock when PWM output is high. If duration =N, need to program N-1 in this register. Note: The duration of PWM must not be 0.

10005098 **PWM2_LDURATION** **PWM2 Low Duration register** **0000000**
1

Bit	31	30	29	28	27	26	25	24	23	22	21	20	19	18	17	16
Name	RESV															
Type	RO															
Reset	0	0	0	0	0	0	0	0	0	0	0	0	0	0	0	0
Bit	15	14	13	12	11	10	9	8	7	6	5	4	3	2	1	0
Name	LDURATION															
Type	RW															
Reset	0	0	0	0	0	0	0	0	0	0	0	0	0	0	0	1

Bit(s)	Name	Description
31:16	RESV	RESERVED
15:0	LDURATION	PWM2 pulse duration based on the current clock when PWM output is low. If duration =N, need to program N-1 in this register. Note: The duration of PWM must not be 0.

1000509C **PWM2_GDURATION** **PWM2 Guard Duration register** **00000000**

Bit	31	30	29	28	27	26	25	24	23	22	21	20	19	18	17	16
Name	RESV															
Type	RO															
Reset	0	0	0	0	0	0	0	0	0	0	0	0	0	0	0	0
Bit	15	14	13	12	11	10	9	8	7	6	5	4	3	2	1	0
Name	GUARD_DURATION															
Type	RW															
Reset	0	0	0	0	0	0	0	0	0	0	0	0	0	0	0	0

Bit(s)	Name	Description
31:16	RESV	RESERVED
15:0	GUARD_DURATION	

100050B0 **PWM2_SEND_DATA0** **PWM2 Send Data0 register** **00000000**

Bit	31	30	29	28	27	26	25	24	23	22	21	20	19	18	17	16
Name	SEND_DATA0[31:16]															
Type	RW															
Reset	0	0	0	0	0	0	0	0	0	0	0	0	0	0	0	0
Bit	15	14	13	12	11	10	9	8	7	6	5	4	3	2	1	0
Name	SEND_DATA0[15:0]															
Type	RW															
Reset	0	0	0	0	0	0	0	0	0	0	0	0	0	0	0	0

Bit(s)	Name	Description
31:0	SEND_DATA0	PWM2 local buffer0 of pulse sequence data to be generated. Note: This value should be written only in periodically FIFO mode. In other mode, this buffer is for internal memory access.

100050B4 **PWM2_SEND_DATA1** **PWM2 Send Data1 register** **00000000**

Bit	31	30	29	28	27	26	25	24	23	22	21	20	19	18	17	16
Name	SEND_DATA1[31:16]															
Type	RW															
Reset	0	0	0	0	0	0	0	0	0	0	0	0	0	0	0	0
Bit	15	14	13	12	11	10	9	8	7	6	5	4	3	2	1	0
Name	SEND_DATA1[15:0]															
Type	RW															
Reset	0	0	0	0	0	0	0	0	0	0	0	0	0	0	0	0

Bit(s)	Name	Description
31:0	SEND_DATA1	PWM2 local buffer0 of pulse sequence data to be generated. Note: This value should be written only in periodically FIFO mode. In other mode, this buffer is for internal memory access.

100050B8 PWM2_WAVE_NUM PWM2 Wave Number register 0000000
0

Bit	31	30	29	28	27	26	25	24	23	22	21	20	19	18	17	16
Name	RESV															
Type	RO															
Reset	0	0	0	0	0	0	0	0	0	0	0	0	0	0	0	0
Bit	15	14	13	12	11	10	9	8	7	6	5	4	3	2	1	0
Name	WAVE_NUM															
Type	RW															
Reset	0	0	0	0	0	0	0	0	0	0	0	0	0	0	0	0

Bit(s)	Name	Description
31:16	RESV	RESERVED
15:0	WAVE_NUM	The number by which PWM2 will generate from the pulse data repeatedly. Note: If WAVE_NUM=0, the waveform generation will not stop until it is disabled.

100050BC PWM2_DATA_WIDTH PWM2 Data Width register 0000000
0

Bit	31	30	29	28	27	26	25	24	23	22	21	20	19	18	17	16
Name	RESV[18:3]															
Type	RO															
Reset	0	0	0	0	0	0	0	0	0	0	0	0	0	0	0	0
Bit	15	14	13	12	11	10	9	8	7	6	5	4	3	2	1	0
Name	RESV[2:0]			DATA_WIDTH												
Type	RO			RW												
Reset	0	0	0	0	0	0	0	0	0	0	0	0	0	0	0	0

Bit(s)	Name	Description
31:13	RESV	RESERVED
12:0	DATA_WIDTH	The PWM2 pulse data width in the old PWM mode.

100050C0 PWM2_THRE_SH PWM2 Thresh register 0000000
0

Bit	31	30	29	28	27	26	25	24	23	22	21	20	19	18	17	16
Name	RESV[18:3]															
Type	RO															
Reset	0	0	0	0	0	0	0	0	0	0	0	0	0	0	0	0
Bit	15	14	13	12	11	10	9	8	7	6	5	4	3	2	1	0
Name	RESV[2:0]			THRESH												
Type	RO			RW												
Reset	0	0	0	0	0	0	0	0	0	0	0	0	0	0	0	0

Bit(s)	Name	Description
31:13	RESV	RESERVED
12:0	THRESH	The PWM2 pulse data high/low switching threshold in the old PWM mode.

100050C4 PWM2_SEND_WAVENUM PWM2 Send Wave Number register 0000000
0

Bit	31	30	29	28	27	26	25	24	23	22	21	20	19	18	17	16
Name	RESV															
Type	RO															
Reset	0	0	0	0	0	0	0	0	0	0	0	0	0	0	0	0

Bit	15	14	13	12	11	10	9	8	7	6	5	4	3	2	1	0
Name	SEND_WAVENUM															
Type	RO															
Reset	0	0	0	0	0	0	0	0	0	0	0	0	0	0	0	0

Bit(s)	Name	Description
31:16	RESV	RESERVED
15:0	SEND_WAVENUM	The number by which PWM2 has already generated from the specified data source in the periodical mode.

100050D0 **PWM3_CON** **PWM3 Control register** **00007E00**

Bit	31	30	29	28	27	26	25	24	23	22	21	20	19	18	17	16
Name	RESV0															
Type	RO															
Reset	0	0	0	0	0	0	0	0	0	0	0	0	0	0	0	0
Bit	15	14	13	12	11	10	9	8	7	6	5	4	3	2	1	0
Name	OLD_PWM_MODE	STOP_BITPOS						GUARD_VALUE	IDLE_VALUE	RESV1			CLKSEL	CLKDIV		
Type	RW	RW						RW	RW	RO			RW	RW		
Reset	0	1	1	1	1	1	1	0	0	0	0	0	0	0	0	0

Bit(s)	Name	Description
31:16	RESV0	RESERVED
15	OLD_PWM_MODE	Use old PWM mode Note: Using old PWM mode also means periodical mode. So SRCSEL and MODE is ignored in this situation. Only old PWM mode with 32 KHz clock source (however could not work in the system sleep-mode). 0: New PWM mode 1: Old PWM mode
14:9	STOP_BITPOS	Note: Using old PWM mode also means periodical mode. So SRCSEL and MODE is ignored in this situation. Only old PWM mode with 32 KHz clock source (however could not work in the system sleep-mode).
8	GUARD_VALUE	PWM3 output value when guard time.
7	IDLE_VALUE	PWM3 output value when idle state.
6:4	RESV1	Select Random Generator mode
3	CLKSEL	Select PWM3 clock 0: CLK= 100KHz 1: CLK= 40MHz
2:0	CLKDIV	Select PWM3 clock scale. 000: CLK Hz 001: CLK/2 Hz 010: CLK/4 Hz 011: CLK/8 Hz 100: CLK/16 Hz 101: CLK/32 Hz 110: CLK/64 Hz 111: CLK/128 Hz

100050D4 **PWM3_HDURATION** **PWM3 High Duration register** **00000001**

Bit	31	30	29	28	27	26	25	24	23	22	21	20	19	18	17	16
Name	RESV															
Type	RO															

Reset	0	0	0	0	0	0	0	0	0	0	0	0	0	0	0	0
Bit	15	14	13	12	11	10	9	8	7	6	5	4	3	2	1	0
Name	HDURATION															
Type	RW															
Reset	0	0	0	0	0	0	0	0	0	0	0	0	0	0	0	1

Bit(s)	Name	Description
31:16	RESV	RESERVED
15:0	HDURATION	PWM3 pulse duration based on the current clock when PWM output is high. If duration =N, need to program N-1 in this register. Note: The duration of PWM must not be 0.

100050D8 PWM3 LDURATION PWM3 Low Duration register **0000000**
1

Bit	31	30	29	28	27	26	25	24	23	22	21	20	19	18	17	16
Name	RESV															
Type	RO															
Reset	0	0	0	0	0	0	0	0	0	0	0	0	0	0	0	0
Bit	15	14	13	12	11	10	9	8	7	6	5	4	3	2	1	0
Name	LDURATION															
Type	RW															
Reset	0	0	0	0	0	0	0	0	0	0	0	0	0	0	0	1

Bit(s)	Name	Description
31:16	RESV	RESERVED
15:0	LDURATION	PWM3 pulse duration based on the current clock when PWM output is low. If duration =N, need to program N-1 in this register. Note: The duration of PWM must not be 0.

100050DC PWM3 GDURATION PWM3 Guard Duration register **0000000**
0

Bit	31	30	29	28	27	26	25	24	23	22	21	20	19	18	17	16
Name	RESV															
Type	RO															
Reset	0	0	0	0	0	0	0	0	0	0	0	0	0	0	0	0
Bit	15	14	13	12	11	10	9	8	7	6	5	4	3	2	1	0
Name	GUARD_DURATION															
Type	RW															
Reset	0	0	0	0	0	0	0	0	0	0	0	0	0	0	0	0

Bit(s)	Name	Description
31:16	RESV	RESERVED
15:0	GUARD_DURATION	

100050F0 PWM3 SEND DATA0 PWM3 Send Data0 register **0000000**
0

Bit	31	30	29	28	27	26	25	24	23	22	21	20	19	18	17	16
Name	SEND_DATA0[31:16]															
Type	RW															
Reset	0	0	0	0	0	0	0	0	0	0	0	0	0	0	0	0
Bit	15	14	13	12	11	10	9	8	7	6	5	4	3	2	1	0
Name	SEND_DATA0[15:0]															
Type	RW															
Reset	0	0	0	0	0	0	0	0	0	0	0	0	0	0	0	0

Bit(s)	Name	Description
31:0	SEND_DATA0	PWM3 local buffer0 of pulse sequence data to be generated. Note: This value should be written only in periodically FIFO mode. In other mode, this buffer is for internal memory access.

100050F4 PWM3_SEND **PWM3 Send Data1 register** **0000000**
DATA1 **0**

Bit	31	30	29	28	27	26	25	24	23	22	21	20	19	18	17	16
Name	SEND_DATA1[31:16]															
Type	RW															
Reset	0	0	0	0	0	0	0	0	0	0	0	0	0	0	0	0
Bit	15	14	13	12	11	10	9	8	7	6	5	4	3	2	1	0
Name	SEND_DATA1[15:0]															
Type	RW															
Reset	0	0	0	0	0	0	0	0	0	0	0	0	0	0	0	0

Bit(s)	Name	Description
31:0	SEND_DATA1	PWM3 local buffer0 of pulse sequence data to be generated. Note: This value should be written only in periodically FIFO mode. In other mode, this buffer is for internal memory access.

100050F8 PWM3_WAVE **PWM3 Wave Number register** **0000000**
NUM **0**

Bit	31	30	29	28	27	26	25	24	23	22	21	20	19	18	17	16
Name	RESV															
Type	RO															
Reset	0	0	0	0	0	0	0	0	0	0	0	0	0	0	0	0
Bit	15	14	13	12	11	10	9	8	7	6	5	4	3	2	1	0
Name	WAVE_NUM															
Type	RW															
Reset	0	0	0	0	0	0	0	0	0	0	0	0	0	0	0	0

Bit(s)	Name	Description
31:16	RESV	RESERVED
15:0	WAVE_NUM	The number by which PWM3 will generate from the pulse data repeatedly. Note: If WAVE_NUM=0, the waveform generation will not stop until it is disabled.

100050FC PWM3_DATA **PWM3 Data Width register** **0000000**
WIDTH **0**

Bit	31	30	29	28	27	26	25	24	23	22	21	20	19	18	17	16
Name	RESV[18:3]															
Type	RO															
Reset	0	0	0	0	0	0	0	0	0	0	0	0	0	0	0	0
Bit	15	14	13	12	11	10	9	8	7	6	5	4	3	2	1	0
Name	RESV[2:0]			DATA_WIDTH												
Type	RO			RW												
Reset	0	0	0	0	0	0	0	0	0	0	0	0	0	0	0	0

Bit(s)	Name	Description
31:13	RESV	RESERVED
12:0	DATA_WIDTH	The PWM3 pulse data width in the old PWM mode.

10005100 PWM3_THRE PWM3 Thresh register 0000000
SH 0

Bit	31	30	29	28	27	26	25	24	23	22	21	20	19	18	17	16
Name	RESV[18:3]															
Type	RO															
Reset	0	0	0	0	0	0	0	0	0	0	0	0	0	0	0	0
Bit	15	14	13	12	11	10	9	8	7	6	5	4	3	2	1	0
Name	RESV[2:0]			THRESH												
Type	RO			RW												
Reset	0	0	0	0	0	0	0	0	0	0	0	0	0	0	0	0

Bit(s)	Name	Description
31:13	RESV	RESERVED
12:0	THRESH	The PWM3 pulse data high/low switching threshold in the old PWM mode.

10005104 PWM3_SEND PWM3 Send Wave Number register 0000000
WAVENUM 0

Bit	31	30	29	28	27	26	25	24	23	22	21	20	19	18	17	16
Name	RESV															
Type	RO															
Reset	0	0	0	0	0	0	0	0	0	0	0	0	0	0	0	0
Bit	15	14	13	12	11	10	9	8	7	6	5	4	3	2	1	0
Name	SEND_WAVENUM															
Type	RO															
Reset	0	0	0	0	0	0	0	0	0	0	0	0	0	0	0	0

Bit(s)	Name	Description
31:16	RESV	RESERVED
15:0	SEND_WAVENUM	The number by which PWM3 has already generated from the specified data source in the periodical mode.

1000520C PWM_EN_ST PWM Enable Status register 0000000
ATUS 0

Bit	31	30	29	28	27	26	25	24	23	22	21	20	19	18	17	16
Name	RESV[27:12]															
Type	RO															
Reset	0	0	0	0	0	0	0	0	0	0	0	0	0	0	0	0
Bit	15	14	13	12	11	10	9	8	7	6	5	4	3	2	1	0
Name	RESV[11:0]												PW M3_ EN_ ST	PW M2_ EN_ ST	PW M1_ EN_ ST	PW M0_ EN_ ST
Type	RO												RO	RO	RO	RO
Reset	0	0	0	0	0	0	0	0	0	0	0	0	0	0	0	0

Bit(s)	Name	Description
31:4	RESV	RESERVED
3	PWM3_EN_ST	PWM3 enable status
2	PWM2_EN_ST	PWM2 enable status
1	PWM1_EN_ST	PWM1 enable status
0	PWM0_EN_ST	PWM0 enable status

5.18 Frame Engine

5.18.1 Registers

SDM Changes LOG

Revision	Date	Author	Change Log
0.1	2013/5/27	PeterCT WU	Initialization

Module name: SDM Base address: (+10100000h)

Address	Name	Width	Register Function
10100800	<u>TX_BASE_PTR_0</u>	32	TX Ring #0 Base Pointer
10100804	<u>TX_MAX_CNT_0</u>	32	TX Ring #0 Maximum Count
10100808	<u>TX_CTX_IDX_0</u>	32	TX Ring #0 CPU pointer
1010080C	<u>TX_DTX_IDX_0</u>	32	TX Ring #0 DMA pointer
10100810	<u>TX_BASE_PTR_1</u>	32	TX Ring #1 Base Pointer
10100814	<u>TX_MAX_CNT_1</u>	32	TX Ring #1 Maximum Count
10100818	<u>TX_CTX_IDX_1</u>	32	TX Ring #1 CPU pointer
1010081C	<u>TX_DTX_IDX_1</u>	32	TX Ring #1 DMA pointer
10100820	<u>TX_BASE_PTR_2</u>	32	TX Ring #2 Base Pointer
10100824	<u>TX_MAX_CNT_2</u>	32	TX Ring #2 Maximum Count
10100828	<u>TX_CTX_IDX_2</u>	32	TX Ring #2 CPU pointer
1010082C	<u>TX_DTX_IDX_2</u>	32	TX Ring #2 DMA pointer
10100830	<u>TX_BASE_PTR_3</u>	32	TX Ring #3 Base Pointer
10100834	<u>TX_MAX_CNT_3</u>	32	TX Ring #3 Maximum Count
10100838	<u>TX_CTX_IDX_3</u>	32	TX Ring #3 CPU pointer
1010083C	<u>TX_DTX_IDX_3</u>	32	TX Ring #3 DMA pointer
10100900	<u>RX_BASE_PTR_0</u>	32	RX Ring #0 Base Pointer
10100904	<u>RX_MAX_CNT_0</u>	32	RX Ring #0 Maximum Count
10100908	<u>RX_CRX_IDX_0</u>	32	RX Ring #0 CPU pointer
1010090C	<u>RX_DRX_IDX_0</u>	32	RX Ring #0 DMA pointer
10100910	<u>RX_BASE_PTR_1</u>	32	RX Ring #1 Base Pointer
10100914	<u>RX_MAX_CNT_1</u>	32	RX Ring #1 Maximum Count
10100918	<u>RX_CRX_IDX_1</u>	32	RX Ring #1 CPU pointer
1010091C	<u>RX_DRX_IDX_1</u>	32	RX Ring #1 DMA pointer
10100A00	<u>PDMA_INFO</u>	32	PDMA Information
10100A04	<u>PDMA_GLO_CFG</u>	32	PDMA Global Configuration
10100A0C	<u>DELAY_INT_CFG</u>	32	Delay Interrupt Configuration
10100A10	<u>FREEQ_THRES</u>	32	Free Queue Threshold
10100A20	<u>INT_STATUS</u>	32	Interrupt Status
10100A28	<u>INT_MASK</u>	32	Interrupt Mask

10100A80	<u>PDMA_SCH</u>	32	Scheduler Configuration for Q0&Q1
10100A84	<u>PDMA_WRR</u>	32	Scheduler Configuration for Q2&Q3
10100C00	<u>SDM_CON</u>	32	Switch DMA Control
10100C04	<u>SDM_RING</u>	32	Switch DMA Rx Ring
10100C08	<u>SDM_TRING</u>	32	Switch DMA TX Ring
10100C0C	<u>SDM_MAC_AD RL</u>	32	Switch MAC Address LSB
10100C10	<u>SDM_MAC_AD RH</u>	32	Switch MAC Address MSB
10100D00	<u>SDM_TPCNT</u>	32	Switch DMA Tx Packet Count
10100D04	<u>SDM_TBCNT</u>	32	Switch DMA TX Byte Count
10100D08	<u>SDM_RPCNT</u>	32	Switch DMA RX Packet Count
10100D0C	<u>SDM_RBCNT</u>	32	Switch DMA RX Byte Count
10100D10	<u>SDM_CS_ERR</u>	32	Switch DMA RX Checksum Error

10100800 **TX_BASE_PT** TX Ring #0 Base Pointer **0000000**
R_0 **0**

Bit	31	30	29	28	27	26	25	24	23	22	21	20	19	18	17	16
Name	TX_BASE_PTR[31:16]															
Type	RW															
Reset	0	0	0	0	0	0	0	0	0	0	0	0	0	0	0	0
Bit	15	14	13	12	11	10	9	8	7	6	5	4	3	2	1	0
Name	TX_BASE_PTR[15:0]															
Type	RW															
Reset	0	0	0	0	0	0	0	0	0	0	0	0	0	0	0	0

Bit(s)	Name	Description
31:0	TX_BASE_PTR	Point to the base address of TX Ring #0 (4-DW aligned address)

10100804 **TX_MAX_CNT** TX Ring #0 Maximum Count **0000000**
0 **0**

Bit	31	30	29	28	27	26	25	24	23	22	21	20	19	18	17	16
Name																
Type																
Reset																
Bit	15	14	13	12	11	10	9	8	7	6	5	4	3	2	1	0
Name					TX_MAX_CNT											
Type					RW											
Reset					0	0	0	0	0	0	0	0	0	0	0	0

Bit(s)	Name	Description
11:0	TX_MAX_CNT	The maximum number of TXD count in TX Ring #0

10100808 **TX_CTX_IDX** TX Ring #0 CPU pointer **0000000**
0 **0**

Bit	31	30	29	28	27	26	25	24	23	22	21	20	19	18	17	16
Name																
Type																
Reset																
Bit	15	14	13	12	11	10	9	8	7	6	5	4	3	2	1	0
Name					TX_CTX_IDX											
Type					RW											
Reset					0	0	0	0	0	0	0	0	0	0	0	0

Bit(s)	Name	Description
11:0	TX_CTX_IDX	Point to the next TXD CPU wants to use

1010080C TX_DTX_IDX TX Ring #0 DMA pointer 0000000
0

Bit	31	30	29	28	27	26	25	24	23	22	21	20	19	18	17	16
Name																
Type																
Reset																
Bit	15	14	13	12	11	10	9	8	7	6	5	4	3	2	1	0
Name	TX_DTX_IDX															
Type	RO															
Reset	0	0	0	0	0	0	0	0	0	0	0	0	0	0	0	0

Bit(s)	Name	Description
11:0	TX_DTX_IDX	Point to the next TXD DMA wants to use

10100810 TX_BASE_PT TX Ring #1 Base Pointer 0000000
R 1 0

Bit	31	30	29	28	27	26	25	24	23	22	21	20	19	18	17	16
Name	TX_BASE_PTR[31:16]															
Type	RW															
Reset	0	0	0	0	0	0	0	0	0	0	0	0	0	0	0	0
Bit	15	14	13	12	11	10	9	8	7	6	5	4	3	2	1	0
Name	TX_BASE_PTR[15:0]															
Type	RW															
Reset	0	0	0	0	0	0	0	0	0	0	0	0	0	0	0	0

Bit(s)	Name	Description
31:0	TX_BASE_PTR	Point to the base address of TX Ring #0 (4-DW aligned address)

10100814 TX_MAX_CNT TX Ring #1 Maximum Count 0000000
1 0

Bit	31	30	29	28	27	26	25	24	23	22	21	20	19	18	17	16
Name																
Type																
Reset																
Bit	15	14	13	12	11	10	9	8	7	6	5	4	3	2	1	0
Name	TX_MAX_CNT															
Type	RW															
Reset	0	0	0	0	0	0	0	0	0	0	0	0	0	0	0	0

Bit(s)	Name	Description
11:0	TX_MAX_CNT	The maximum number of TXD count in TX Ring #0

10100818 TX_CTX_IDX TX Ring #1 CPU pointer 0000000
1 0

Bit	31	30	29	28	27	26	25	24	23	22	21	20	19	18	17	16
Name																
Type																
Reset																
Bit	15	14	13	12	11	10	9	8	7	6	5	4	3	2	1	0
Name	TX_CTX_IDX															
Type	RW															

Reset																
-------	--	--	--	--	--	--	--	--	--	--	--	--	--	--	--	--

Bit(s)	Name	Description
11:0	TX_CTX_IDX	Point to the next TXD CPU wants to use

1010081C TX DTX_IDX TX Ring #1 DMA pointer 0000000
1

Bit	31	30	29	28	27	26	25	24	23	22	21	20	19	18	17	16
Name																
Type																
Reset																
Bit	15	14	13	12	11	10	9	8	7	6	5	4	3	2	1	0
Name	TX_DTX_IDX															
Type	RO															
Reset	0	0	0	0	0	0	0	0	0	0	0	0	0	0	0	0

Bit(s)	Name	Description
11:0	TX_DTX_IDX	Point to the next TXD DMA wants to use

10100820 TX_BASE_PT TX Ring #2 Base Pointer 0000000
R_2

Bit	31	30	29	28	27	26	25	24	23	22	21	20	19	18	17	16
Name	TX_BASE_PTR[31:16]															
Type	RW															
Reset	0	0	0	0	0	0	0	0	0	0	0	0	0	0	0	0
Bit	15	14	13	12	11	10	9	8	7	6	5	4	3	2	1	0
Name	TX_BASE_PTR[15:0]															
Type	RW															
Reset	0	0	0	0	0	0	0	0	0	0	0	0	0	0	0	0

Bit(s)	Name	Description
31:0	TX_BASE_PTR	Point to the base address of TX Ring #0 (4-DW aligned address)

10100824 TX_MAX_CNT TX Ring #2 Maximum Count 0000000
2

Bit	31	30	29	28	27	26	25	24	23	22	21	20	19	18	17	16
Name																
Type																
Reset																
Bit	15	14	13	12	11	10	9	8	7	6	5	4	3	2	1	0
Name	TX_MAX_CNT															
Type	RW															
Reset	0	0	0	0	0	0	0	0	0	0	0	0	0	0	0	0

Bit(s)	Name	Description
11:0	TX_MAX_CNT	The maximum number of TXD count in TX Ring #0

10100828 TX_CTX_IDX TX Ring #2 CPU pointer 0000000
2

Bit	31	30	29	28	27	26	25	24	23	22	21	20	19	18	17	16
Name																
Type																
Reset																

Bit	15	14	13	12	11	10	9	8	7	6	5	4	3	2	1	0
Name	TX_CTX_IDX															
Type	RW															
Reset	0	0	0	0	0	0	0	0	0	0	0	0	0	0	0	0

Bit(s)	Name	Description
11:0	TX_CTX_IDX	Point to the next TXD CPU wants to use

1010082C TX DTX_IDX TX Ring #2 DMA pointer 0000000
2 0

Bit	31	30	29	28	27	26	25	24	23	22	21	20	19	18	17	16
Name	TX_DTX_IDX															
Type	RW															
Reset	0															
Bit	15	14	13	12	11	10	9	8	7	6	5	4	3	2	1	0
Name	TX_DTX_IDX															
Type	RO															
Reset	0	0	0	0	0	0	0	0	0	0	0	0	0	0	0	0

Bit(s)	Name	Description
11:0	TX_DTX_IDX	Point to the next TXD DMA wants to use

10100830 TX_BASE_PT TX Ring #3 Base Pointer 0000000
R_3 0

Bit	31	30	29	28	27	26	25	24	23	22	21	20	19	18	17	16
Name	TX_BASE_PTR[31:16]															
Type	RW															
Reset	0	0	0	0	0	0	0	0	0	0	0	0	0	0	0	0
Bit	15	14	13	12	11	10	9	8	7	6	5	4	3	2	1	0
Name	TX_BASE_PTR[15:0]															
Type	RW															
Reset	0	0	0	0	0	0	0	0	0	0	0	0	0	0	0	0

Bit(s)	Name	Description
31:0	TX_BASE_PTR	Point to the base address of TX Ring #0 (4-DW aligned address)

10100834 TX_MAX_CNT TX Ring #3 Maximum Count 0000000
3 0

Bit	31	30	29	28	27	26	25	24	23	22	21	20	19	18	17	16
Name	TX_MAX_CNT															
Type	RW															
Reset	0															
Bit	15	14	13	12	11	10	9	8	7	6	5	4	3	2	1	0
Name	TX_MAX_CNT															
Type	RW															
Reset	0	0	0	0	0	0	0	0	0	0	0	0	0	0	0	0

Bit(s)	Name	Description
11:0	TX_MAX_CNT	The maximum number of TXD count in TX Ring #0

10100838 TX_CTX_IDX TX Ring #3 CPU pointer 0000000
3 0

Bit	31	30	29	28	27	26	25	24	23	22	21	20	19	18	17	16
-----	----	----	----	----	----	----	----	----	----	----	----	----	----	----	----	----

Name																
Type																
Reset																
Bit	15	14	13	12	11	10	9	8	7	6	5	4	3	2	1	0
Name	TX_CTX_IDX															
Type	RW															
Reset	0	0	0	0	0	0	0	0	0	0	0	0	0	0	0	0

Bit(s)	Name	Description
11:0	TX_CTX_IDX	Point to the next TXD CPU wants to use

1010083C TX DTX_IDX TX Ring #3 DMA poitner 0000000
3 0

Bit	31	30	29	28	27	26	25	24	23	22	21	20	19	18	17	16
Name																
Type																
Reset																
Bit	15	14	13	12	11	10	9	8	7	6	5	4	3	2	1	0
Name	TX_DTX_IDX															
Type	RO															
Reset	0	0	0	0	0	0	0	0	0	0	0	0	0	0	0	0

Bit(s)	Name	Description
11:0	TX_DTX_IDX	Point to the next TXD DMA wants to use

10100900 RX_BASE_PT RX Ring #0 Base Pointer 0000000
R_0 0

Bit	31	30	29	28	27	26	25	24	23	22	21	20	19	18	17	16
Name	RX_BASE_PTR[31:16]															
Type	RW															
Reset	0	0	0	0	0	0	0	0	0	0	0	0	0	0	0	0
Bit	15	14	13	12	11	10	9	8	7	6	5	4	3	2	1	0
Name	RX_BASE_PTR[15:0]															
Type	RW															
Reset	0	0	0	0	0	0	0	0	0	0	0	0	0	0	0	0

Bit(s)	Name	Description
31:0	RX_BASE_PTR	Point to the base address of RX Ring #0 (4-DW aligned address)

10100904 RX_MAX_CNT RX Ring #0 Maximum Count 0000000
0 0

Bit	31	30	29	28	27	26	25	24	23	22	21	20	19	18	17	16
Name																
Type																
Reset																
Bit	15	14	13	12	11	10	9	8	7	6	5	4	3	2	1	0
Name	TX_MAX_CNT															
Type	RW															
Reset	0	0	0	0	0	0	0	0	0	0	0	0	0	0	0	0

Bit(s)	Name	Description
11:0	TX_MAX_CNT	The maximum number of RXD count in RX Ring #0

10100908 RX_CRX_IDX RX Ring #0 CPU pointer 0000000

0

0

Bit	31	30	29	28	27	26	25	24	23	22	21	20	19	18	17	16
Name																
Type																
Reset																
Bit	15	14	13	12	11	10	9	8	7	6	5	4	3	2	1	0
Name	TX_CTX_IDX															
Type	RW															
Reset					0	0	0	0	0	0	0	0	0	0	0	0

Bit(s)	Name	Description
11:0	TX_CTX_IDX	Point to the next RXD CPU wants to use

1010090C RX_DRX_IDX RX Ring #0 DMA pointer 0000000
0

Bit	31	30	29	28	27	26	25	24	23	22	21	20	19	18	17	16
Name																
Type																
Reset																
Bit	15	14	13	12	11	10	9	8	7	6	5	4	3	2	1	0
Name	RX_DRX_IDX															
Type	RO															
Reset					0	0	0	0	0	0	0	0	0	0	0	0

Bit(s)	Name	Description
11:0	RX_DRX_IDX	Point to the next RXD DMA wants to use

10100910 RX_BASE_PT RX Ring #1 Base Pointer 0000000
R_1 0

Bit	31	30	29	28	27	26	25	24	23	22	21	20	19	18	17	16
Name	RX_BASE_PTR[31:16]															
Type	RW															
Reset	0	0	0	0	0	0	0	0	0	0	0	0	0	0	0	0
Bit	15	14	13	12	11	10	9	8	7	6	5	4	3	2	1	0
Name	RX_BASE_PTR[15:0]															
Type	RW															
Reset	0	0	0	0	0	0	0	0	0	0	0	0	0	0	0	0

Bit(s)	Name	Description
31:0	RX_BASE_PTR	Point to the base address of RX Ring #0 (4-DW aligned address)

10100914 RX_MAX_CNT RX Ring #1 Maximum Count 0000000
1 0

Bit	31	30	29	28	27	26	25	24	23	22	21	20	19	18	17	16
Name																
Type																
Reset																
Bit	15	14	13	12	11	10	9	8	7	6	5	4	3	2	1	0
Name	TX_MAX_CNT															
Type	RW															
Reset					0	0	0	0	0	0	0	0	0	0	0	0

Bit(s)	Name	Description
11:0	TX_MAX_CNT	The maximum number of RXD count in RX Ring #0

10100918 RX_CRX_IDX RX Ring #1 CPU pointer 0000000
1 0

Bit	31	30	29	28	27	26	25	24	23	22	21	20	19	18	17	16
Name																
Type																
Reset																
Bit	15	14	13	12	11	10	9	8	7	6	5	4	3	2	1	0
Name					TX_CTX_IDX											
Type					RW											
Reset					0	0	0	0	0	0	0	0	0	0	0	0

Bit(s)	Name	Description
11:0	TX_CTX_IDX	Point to the next RXD CPU wants to use

1010091C RX_DRX_IDX RX Ring #1 DMA pointer 0000000
1 0

Bit	31	30	29	28	27	26	25	24	23	22	21	20	19	18	17	16
Name																
Type																
Reset																
Bit	15	14	13	12	11	10	9	8	7	6	5	4	3	2	1	0
Name					RX_DRX_IDX											
Type					RO											
Reset					0	0	0	0	0	0	0	0	0	0	0	0

Bit(s)	Name	Description
11:0	RX_DRX_IDX	Point to the next RXD DMA wants to use

10100A00 PDMA_INFO PDMA Information 1C00020
4

Bit	31	30	29	28	27	26	25	24	23	22	21	20	19	18	17	16
Name					INDEX_WIDTH				BASE_PTR_WIDTH							
Type					RO				RO							
Reset					1	1	0	0	0	0	0	0	0	0	0	0
Bit	15	14	13	12	11	10	9	8	7	6	5	4	3	2	1	0
Name	RX_RING_NUM								TX_RING_NUM							
Type	RO								RO							
Reset	0	0	0	0	0	0	1	0	0	0	0	0	0	1	0	0

Bit(s)	Name	Description
27:24	INDEX_WIDTH	Point to the next RXD CPU wants to use
23:16	BASE_PTR_WIDTH	Base pointer width, x Base_addr[31:32-x] is shared with all ring base addresss. Only ring #0 base address[31:32-x] field is writabl. [note]: "0" means no bit of base_address is shared.
15:8	RX_RING_NUM	Rx ring number
7:0	TX_RING_NUM	Tx ring number

10100A04 PDMA_GLO_CFG PDMA Global Configuration 0000005
0

Bit	31	30	29	28	27	26	25	24	23	22	21	20	19	18	17	16
Name					HDR_SEG_LEN											
Type					RW											

Reset			0	0	0	0	0	0	0	0	0	0	0	0	0	0
Bit	15	14	13	12	11	10	9	8	7	6	5	4	3	2	1	0
Name									BIG_ENDIAN	TX_WB_DONE	PDMA_BT_SIZE	RX_DMA_BUSY	RX_DMA_EN	TX_DMA_BUSY	TX_DMA_EN	
Type									RW	RW	RW	RO	RW	RO	RW	
Reset									0	1	0	1	0	0	0	0

Bit(s)	Name	Description
29:16	HDR_SEG_LEN	Header Segment Length Specify the header segment size in byte to support RX header/payload scattering function, when set to a non-zero value. When set to zero, the header/payload scattering feature is disabled.
7	BIG_ENDIAN	Big endian 0: PDMA will not do byte swapping for TX/RX packet header and payload 1: PDMA will do byte swapping for TX/RX packet header and payload
6	TX_WB_DONE	0: Disable TX_DMA writing back DDONE into TXD 1: Enable TX_DMA writing back DDONE into TXD
5:4	PDMA_BT_SIZE	The burst size of PDMA 0: 4 DWORDs (16-bytes) 1: 8 DWORDs (32-bytes) 2: 16 DWORDs (64-bytes) 3: Reserved
3	RX_DMA_BUSY	0: RX_DMA is not busy 1: RX_DMA is busy
2	RX_DMA_EN	0: Disable RX_DMA (when disabled, RX_DMA will finish the current receiving packet, then stop) 1: Enable RX_DMA
1	TX_DMA_BUSY	0: TX_DMA is not busy 1: TX_DMA is busy
0	TX_DMA_EN	0: Disable TX_DMA (when disabled, TX_DMA will finish the current sending packet, then stop) 1: Enable TX_DMA

10100A0C DELAY_INT_C Delay Interrupt Configuration 0000000
FG 0

Bit	31	30	29	28	27	26	25	24	23	22	21	20	19	18	17	16	
Name	TXDLY_INT_EN	TXMAX_PINT								TXMAX_PTIME							
Type	RW	RW								RW							
Reset	0	0	0	0	0	0	0	0	0	0	0	0	0	0	0	0	
Bit	15	14	13	12	11	10	9	8	7	6	5	4	3	2	1	0	
Name	RX_DLY_INT_EN	RXMAX_PINT								RXMAX_PTIME							
Type	RW	RW								RW							
Reset	0	0	0	0	0	0	0	0	0	0	0	0	0	0	0	0	

Bit(s)	Name	Description
31	TXDLY_INT_EN	Delay interrupt mechanism 0: Disable TX delayed interrupt mechanism 1: Enable Tx delayed interrupt mechanism
30:24	TXMAX_PINT	Specified Max. number of pended interrupts When the number of pended interrupts is equal or greater than the value

Bit(s)	Name	Description
23:16	TXMAX_PTIME	specified here or interrupt pending time reach the limit (see below), an final TX_DLY_INT is generated. [Note] reset to 0 can disable pending interrupt count check. Specified Max. pended time When the pending time is equal or greater than TXMAX_PTIME x 20us or the number of pended TX_DONE is equal or greater than TXMAX_PINT 9(see above), an final TX_DLY_INT is generated. [Note] reset to 0 can disable pending interrupt time check.
15	RXDLY_INT_EN	0: Disable Rx delayed interrupt mechanism 1: Enable Rx delayed interrupt mechanism
14:8	RXMAX_PINT	Specified Max. number of pended interrupts When the number of pended interrupts is equal or greater than the value specified here or interrupt pending time reach the limit (see below), an final RX_DLY_INT is generated. [Note] reset to 0 can disable pending interrupt count check.
7:0	RXMAX_PTIME	Specified Max. pended time When the pending time is equal or greater than RXMAX_PTIME x 20us or the number of pended RX_DONE is equal or greater than RXMAX_PINT 9(see above), an finalRX_DLY_INT is generated. [Note] reset to 0 can disable pending interrupt time check.

10100A10 **FREQ THRES** Free Queue Threshold 0000000
S 2

Bit	31	30	29	28	27	26	25	24	23	22	21	20	19	18	17	16	
Name																	
Type																	
Reset																	
Bit	15	14	13	12	11	10	9	8	7	6	5	4	3	2	1	0	
Name													FREQ_THRES				
Type														RW			
Reset													0	0	1	0	

Bit(s)	Name	Description
3:0	FREQ_THRES	Rx free queue threshold PDMA will stop DMA interface when left RX descriptors reach this threshold

10100A20 **INT_STATUS** Interrupt Status 0000000
0

Bit	31	30	29	28	27	26	25	24	23	22	21	20	19	18	17	16
Name	RX_COHE_RENT	RX_DL_Y_INT	TX_COHE_RENT	TX_DL_Y_INT											RX_DO_NE_INT_1	RX_DO_NE_INT_0
Type	W1C	W1C	W1C	W1C											W1C	W1C
Reset	0	0	0	0											0	0
Bit	15	14	13	12	11	10	9	8	7	6	5	4	3	2	1	0
Name													TX_DO_NE_INT_3	TX_DO_NE_INT_2	TX_DO_NE_INT_1	TX_DO_NE_INT_0
Type													W1C	W1C	W1C	W1C
Reset													0	0	0	0

Bit(s)	Name	Description
--------	------	-------------

Bit(s)	Name	Description
31	RX_COHERENT	RX_DMA finds data coherent event while checking ddone bit.
30	RX_DLY_INT	Summary of the whole PDMA Rx related interrupts.
29	TX_COHERENT	TX_DMA finds data coherent event while checking ddone bit.
28	TX_DLY_INT	Summary of the whole PDMA Tx related interrupts.
17	RX_DONE_INT1	Rx ring #1 packet receive interrupt
16	RX_DONE_INT0	Rx ring #0 packet receive interrupt
3	TX_DONE_INT3	Tx ring #3 packet transmit interrupt
2	TX_DONE_INT2	Tx ring #2 packet transmit interrupt
1	TX_DONE_INT1	Tx ring #1 packet transmit interrupt
0	TX_DONE_INT0	Tx ring #0 packet transmit interrupt

10100A28 INT_MASK Interrupt Mask 0000000
0

Bit	31	30	29	28	27	26	25	24	23	22	21	20	19	18	17	16
Name	RX_COHERENT	RX_DLY_INT	TX_COHERENT	TX_DLY_INT											RX_DONE_INT1	RX_DONE_INT0
Type	RW	RW	RW	RW											RW	RW
Reset	0	0	0	0											0	0
Bit	15	14	13	12	11	10	9	8	7	6	5	4	3	2	1	0
Name													TX_DONE_INT3	TX_DONE_INT2	TX_DONE_INT1	TX_DONE_INT0
Type													RW	RW	RW	RW
Reset													0	0	0	0

Bit(s)	Name	Description
31	RX_COHERENT	Interrupt enable for RX_DMA data coherent vent 0: Disable interrupt 1: Enable interrupt
30	RX_DLY_INT	Summary of the whole PDMA Rx related interrupts. 0: Disable interrupt 1: Enable interrupt
29	TX_COHERENT	Interrupt enable for TX_DMA data coherent vent 0: Disable interrupt 1: Enable interrupt
28	TX_DLY_INT	Summary of the whole PDMA Tx related interrupts. 0: Disable interrupt 1: Enable interrupt
17	RX_DONE_INT1	Rx ring #1 packet receive interrupt 0: Disable interrupt 1: Enable interrupt
16	RX_DONE_INT0	Rx ring #0 packet receive interrupt 0: Disable interrupt 1: Enable interrupt
3	TX_DONE_INT3	Tx ring #3 packet transmit interrupt 0: Disable interrupt 1: Enable interrupt
2	TX_DONE_INT2	Tx ring #2 packet transmit interrupt 0: Disable interrupt 1: Enable interrupt
1	TX_DONE_INT1	Tx ring #1 packet transmit interrupt

Bit(s)	Name	Description
0	TX_DONE_INT0	0: Disable interrupt 1: Enable interrupt Tx ring #0 packet transmit interrupt 0: Disable interrupt 1: Enable interrupt

10100A80 PDMA_SCH Scheduler Configuration for Q0&Q1 0000000
0

Bit	31	30	29	28	27	26	25	24	23	22	21	20	19	18	17	16
Name							SCH_MOD									
Type							E									
Reset							RW									
Bit	15	14	13	12	11	10	9	8	7	6	5	4	3	2	1	0
Name																
Type																
Reset																

Bit(s)	Name	Description
25:24	SCH_MODE	Scheduling Mode 00: WRR 01: Strict priority, Q3>Q2,Q1>Q0 10: Mixed mode, Q3>WRR(Q2,Q1,Q0) 11: Mixed mode, Q3>Q2>WRR(Q1,Q0)

10100A84 PDMA_WRR Scheduler Configuration for Q2&Q3 0000000
0

Bit	31	30	29	28	27	26	25	24	23	22	21	20	19	18	17	16
Name																
Type																
Reset																
Bit	15	14	13	12	11	10	9	8	7	6	5	4	3	2	1	0
Name	SCH_WT_Q3				SCH_WT_Q2				SCH_WT_Q1				SCH_WT_Q0			
Type	RW				RW				RW				RW			
Reset	0				0				0				0			

Bit(s)	Name	Description
14:12	SCH_WT_Q3	Scheduling Weight of TX Q3
10:8	SCH_WT_Q2	Scheduling Weight of TX Q2
6:4	SCH_WT_Q1	Scheduling Weight of TX Q1
2:0	SCH_WT_Q0	Scheduling Weight of TX Q0

10100C00 SDM_CON Switch DMA Control 0007810
0

Bit	31	30	29	28	27	26	25	24	23	22	21	20	19	18	17	16
Name	REV0								PD MA _FC	PO RT _MA P	LO OP _EN	TC O_8 1xx	UN _D RO P_E N	UD PC S	TC PC S	IPC S
Type	RO								RW	RW	RW	RW	RW	RW	RW	RW
Reset	0	0	0	0	0	0	0	0	0	0	0	0	0	1	1	1
Bit	15	14	13	12	11	10	9	8	7	6	5	4	3	2	1	0
Name	EXT_VLAN															
Type	RW															

Reset	1	0	0	0	0	0	0	0	1	0	0	0	0	0	0	0
--------------	---	---	---	---	---	---	---	---	---	---	---	---	---	---	---	---

Bit(s)	Name	Description
31:24	REV0	Reserved
23	PDMA_FC	TX PDMA Flow Control Enable When this bit is set, the downstream flow control is enabled on PDMA 4 TX Ring (SDM_TRGING) 0: Disable 1: Enable
22	PORT_MAP	RX Ring Selection The received frame will be collected into the corresponding PDMA RX Ring based on the source port priority tag. 0: Priority Tag (SDMRRING[7:0]) 1: Source Port (SDM_RRING[12:8])
21	LOOP_EN	Frame Engine Loop-back Mode Enable
20	TCO_81xx	Special tag Recognition Enable When this bit is set, PDI(0x81xx) is recognized by the first byte (0x81) only. The second byte could be used for the special purpose like the incoming source port.
19	UN_DROP_EN	Drop Unknown MAC Address 0: Disable 1: Enable
18	UDPCS	UDP Packet Checksum RX Offload Enable 0: disable, checksum result is showed on RX descriptor 1: enable, drop checksum error packet
17	TCPCS	TCP Packet Checksum RX Offload Enable 0: disable, checksum result is showed on RX descriptor 1: enable, drop checksum error packet
16	IPCS	IP Header Checksum RX Offload Enable 0: disable, checksum result is showed on RX descriptor 1: enable, drop checksum error packet
15:0	EXT_VLAN	Outer VLAN Protocol ID The specific value is used to recognize the outer VLAN protocol ID only. Per inner VLAN or the general VLAN-tagged frame, the value PID=0x8100 is the unique protocol ID.

10100C04 **SDM_RING** **Switch DMA Rx Ring** **0000000**

Bit	31	30	29	28	27	26	25	24	23	22	21	20	19	18	17	16
Name	REV0												QU E3_RIN G_F C	QU E2_RIN G_F C	QU E1_RIN G_F C	QU E0_RIN G_F C
Type	RO												RW	RW	RW	RW
Reset	0	0	0	0	0	0	0	0	0	0	0	0	0	0	0	0
Bit	15	14	13	12	11	10	9	8	7	6	5	4	3	2	1	0
Name				PO RT4_RI NG	PO RT3_RI NG	PO RT2_RI NG	PO RT1_RI NG	PO RT0_RI NG	PRI 7_R ING	PRI 6_R ING	PRI 5_R ING	PRI 4_R ING	PRI 3_R ING	PRI 2_R ING	PRI 1_R ING	PRI 0_R ING
Type				RW	RW	RW	RW	RW	RW	RW	RW	RW	RW	RW	RW	RW
Reset				0	0	0	0	0	0	0	0	0	0	0	0	0

Bit(s)	Name	Description
31:20	REV0	Reserved
19	QUE3_RING_FC	Pause Switch Queue 3 by RX Ring## When RX Ring# reaches the reserved free threshold(FREEQ_THRES), the queue 3 to CPU will be paused.

Bit(s)	Name	Description
		1: RX Ring #0 0: RX Ring #1
18	QUE2_RING_FC	Pause Switch Queue 2 by RX Ring## When RX Ring# reaches the reserved free threshold(FREEQ_THRES), the queue 3 to CPU will be paused. 1: RX Ring #0 0: RX Ring #1
17	QUE1_RING_FC	Pause Switch Queue 1 by RX Ring## When RX Ring# reaches the reserved free threshold(FREEQ_THRES), the queue 3 to CPU will be paused. 1: RX Ring #0 0: RX Ring #1
16	QUE0_RING_FC	Pause Switch Queue 0 by RX Ring## When RX Ring# reaches the reserved free threshold(FREEQ_THRES), the queue 3 to CPU will be paused. 1: RX Ring #0 0: RX Ring #1
12	PORT4_RING	Source Port 4 to RX Ring## The received frames from the source port 4 will be sent to RX Ring# [Note] To use the source port, the special tag between FE and SW should be enabled. 1: RX Ring #0 0: RX Ring #1
11	PORT3_RING	Source Port 3 to RX Ring## The received frames from the source port 4 will be sent to RX Ring# [Note] To use the source port, the special tag between FE and SW should be enabled. 1: RX Ring #0 0: RX Ring #1
10	PORT2_RING	Source Port 2 to RX Ring## The received frames from the source port 4 will be sent to RX Ring# [Note] To use the source port, the special tag between FE and SW should be enabled. 1: RX Ring #0 0: RX Ring #1
9	PORT1_RING	Source Port 1 to RX Ring## The received frames from the source port 4 will be sent to RX Ring# [Note] To use the source port, the special tag between FE and SW should be enabled. 1: RX Ring #0 0: RX Ring #1
8	PORT0_RING	Source Port 0 to RX Ring## The received frames from the source port 4 will be sent to RX Ring# [Note] To use the source port, the special tag between FE and SW should be enabled. 1: RX Ring #0 0: RX Ring #1
7	PRI7_RING	Priority 7 to RX Ring## The received frames with priority tag 7 will be sent to RX Ring# 1: RX Ring #0 0: RX Ring #1
6	PRI6_RING	Priority 6 to RX Ring## The received frames with priority tag 6 will be sent to RX Ring# 1: RX Ring #0 0: RX Ring #1
5	PRI5_RING	Priority 5 to RX Ring## The received frames with priority tag 5 will be sent to RX Ring# 1: RX Ring #0 0: RX Ring #1
4	PRI4_RING	Priority 4 to RX Ring## The received frames with priority tag 4 will be sent to RX Ring#

Bit(s)	Name	Description
3	PRI3_RING	<p>1: RX Ring #0 0: RX Ring #1</p> <p>Priority 3 to RX Ring##</p> <p>The received frames with priority tag 3 will be sent to RX Ring#</p> <p>1: RX Ring #0 0: RX Ring #1</p>
2	PRI2_RING	<p>Priority 2 to RX Ring##</p> <p>The received frames with priority tag 2 will be sent to RX Ring#</p> <p>1: RX Ring #0 0: RX Ring #1</p>
1	PRI1_RING	<p>Priority 1to RX Ring##</p> <p>The received frames with priority tag 1 will be sent to RX Ring#</p> <p>1: RX Ring #0 0: RX Ring #1</p>
0	PRI10_RING	<p>Priority 0 to RX Ring##</p> <p>The received frames with priority tag 0 will be sent to RX Ring#</p> <p>1: RX Ring #0 0: RX Ring #1</p>

10100C08 SDM_TRING Switch DMA TX Ring 0000000
0

Bit	31	30	29	28	27	26	25	24	23	22	21	20	19	18	17	16
Name	RING3_WAN_FC				RING2_WAN_FC				RING1_WAN_FC				RING0_WAN_FC			
Type	RW				RW				RW				RW			
Reset	0	0	0	0	0	0	0	0	0	0	0	0	0	0	0	0
Bit	15	14	13	12	11	10	9	8	7	6	5	4	3	2	1	0
Name	RING3_LAN_FC				RING2_LAN_FC				RING1_LAN_FC				RING0_LAN_FC			
Type	RW				RW				RW				RW			
Reset	0	0	0	0	0	0	0	0	0	0	0	0	0	0	0	0

Bit(s)	Name	Description
31:28	RING3_WAN_FC	<p>Pause TX Ring 3 by WAN Port</p> <p>TX Ring# will be paused when the corresponding switch egress queue on WAN port is congested.</p> <p>Bit.3: WAN port Queue#3 Bit.2: WAN port Queue#2 Bit.1: WAN port Queue#1 Bit.0: WAN port Queue#0</p>
27:24	RING2_WAN_FC	<p>Pause TX Ring 2 by WAN Port</p> <p>TX Ring# will be paused when the corresponding switch egress queue on WAN port is congested.</p> <p>Bit.3: WAN port Queue#3 Bit.2: WAN port Queue#2 Bit.1: WAN port Queue#1 Bit.0: WAN port Queue#0</p>
23:20	RING1_WAN_FC	<p>Pause TX Ring 1 by WAN Port</p> <p>TX Ring# will be paused when the corresponding switch egress queue on WAN port is congested.</p> <p>Bit.3: WAN port Queue#3 Bit.2: WAN port Queue#2 Bit.1: WAN port Queue#1 Bit.0: WAN port Queue#0</p>
19:16	RING0_WAN_FC	<p>Pause TX Ring 0 by WAN Port</p> <p>TX Ring# will be paused when the corresponding switch egress queue on WAN port is congested.</p> <p>Bit.3: WAN port Queue#3 Bit.2: WAN port Queue#2 Bit.1: WAN port Queue#1 Bit.0: WAN port Queue#0</p>

Bit(s)	Name	Description
15:12	RING3_LAN_FC	Pause TX Ring 3 by LAN Port TX Ring# will be paused when the corresponding switch egress queue on WAN port is congested. Bit.3: LAN port Queue#3 Bit.2: LAN port Queue#2 Bit.1: LAN port Queue#1 Bit.0: LAN port Queue#0
11:8	RING2_LAN_FC	Pause TX Ring 2 by LAN Port TX Ring# will be paused when the corresponding switch egress queue on WAN port is congested. Bit.3: LAN port Queue#3 Bit.2: LAN port Queue#2 Bit.1: LAN port Queue#1 Bit.0: LAN port Queue#0
7:4	RING1_LAN_FC	Pause TX Ring 1 by LAN Port TX Ring# will be paused when the corresponding switch egress queue on WAN port is congested. Bit.3: LAN port Queue#3 Bit.2: LAN port Queue#2 Bit.1: LAN port Queue#1 Bit.0: LAN port Queue#0
3:0	RING0_LAN_FC	Pause TX Ring 0 by LAN Port TX Ring# will be paused when the corresponding switch egress queue on WAN port is congested. Bit.3: LAN port Queue#3 Bit.2: LAN port Queue#2 Bit.1: LAN port Queue#1 Bit.0: LAN port Queue#0

10100C0C SDM_MAC_A Switch MAC Address LSB 0000000
DRL 0

Bit	31	30	29	28	27	26	25	24	23	22	21	20	19	18	17	16
Name	MAC_ADDR_LSB[31:16]															
Type	RW															
Reset	0	0	0	0	0	0	0	0	0	0	0	0	0	0	0	0
Bit	15	14	13	12	11	10	9	8	7	6	5	4	3	2	1	0
Name	MAC_ADDR_LSB[15:0]															
Type	RW															
Reset	0	0	0	0	0	0	0	0	0	0	0	0	0	0	0	0

Bit(s)	Name	Description
31:0	MAC_ADDR_LSB	MAC Address bit[31:0]

10100C10 SDM_MAC_A Switch MAC Address MSB 0000000
DRH 0

Bit	31	30	29	28	27	26	25	24	23	22	21	20	19	18	17	16
Name																
Type																
Reset																
Bit	15	14	13	12	11	10	9	8	7	6	5	4	3	2	1	0
Name	MAC_ADDR_MSB															
Type	RW															
Reset	0	0	0	0	0	0	0	0	0	0	0	0	0	0	0	0

Bit(s)	Name	Description
15:0	MAC_ADDR_MSB	MAC Address bit[47:32]

10100D00 SDM_TPCNT Switch DMA Tx Packet Count 0000000
0

Bit	31	30	29	28	27	26	25	24	23	22	21	20	19	18	17	16
Name	TX_PCNT[31:16]															
Type	RC															
Reset	0	0	0	0	0	0	0	0	0	0	0	0	0	0	0	0
Bit	15	14	13	12	11	10	9	8	7	6	5	4	3	2	1	0
Name	TX_PCNT[15:0]															
Type	RC															
Reset	0	0	0	0	0	0	0	0	0	0	0	0	0	0	0	0

Bit(s)	Name	Description
31:0	TX_PCNT	Transmit Packet Count

10100D04 SDM_TBCNT Switch DMA TX Byte Count 0000000
0

Bit	31	30	29	28	27	26	25	24	23	22	21	20	19	18	17	16
Name	TX_BCNT[31:16]															
Type	RC															
Reset	0	0	0	0	0	0	0	0	0	0	0	0	0	0	0	0
Bit	15	14	13	12	11	10	9	8	7	6	5	4	3	2	1	0
Name	TX_BCNT[15:0]															
Type	RC															
Reset	0	0	0	0	0	0	0	0	0	0	0	0	0	0	0	0

Bit(s)	Name	Description
31:0	TX_BCNT	Transmit Byte Count

10100D08 SDM_RPCNT Switch DMA RX Packet Count 0000000
0

Bit	31	30	29	28	27	26	25	24	23	22	21	20	19	18	17	16
Name	RX_PCNT[31:16]															
Type	RC															
Reset	0	0	0	0	0	0	0	0	0	0	0	0	0	0	0	0
Bit	15	14	13	12	11	10	9	8	7	6	5	4	3	2	1	0
Name	RX_PCNT[15:0]															
Type	RC															
Reset	0	0	0	0	0	0	0	0	0	0	0	0	0	0	0	0

Bit(s)	Name	Description
31:0	RX_PCNT	Receive Packet Count

10100D0C SDM_RBCNT Switch DMA RX Byte Count 0000000
0

Bit	31	30	29	28	27	26	25	24	23	22	21	20	19	18	17	16
Name	RX_BCNT[31:16]															
Type	RC															
Reset	0	0	0	0	0	0	0	0	0	0	0	0	0	0	0	0
Bit	15	14	13	12	11	10	9	8	7	6	5	4	3	2	1	0
Name	RX_BCNT[15:0]															
Type	RC															
Reset	0	0	0	0	0	0	0	0	0	0	0	0	0	0	0	0

Bit(s)	Name	Description
--------	------	-------------

Bit(s)	Name	Description
31:0	RX_BCNT	Receive Byte Count

10100D10 **SDM_CS_ERR** Switch DMA RX Checksum Error 0000000
0

Bit	31	30	29	28	27	26	25	24	23	22	21	20	19	18	17	16
Name	CS_ERR_CNT[31:16]															
Type	RC															
Reset	0	0	0	0	0	0	0	0	0	0	0	0	0	0	0	0
Bit	15	14	13	12	11	10	9	8	7	6	5	4	3	2	1	0
Name	CS_ERR_CNT[15:0]															
Type	RC															
Reset	0	0	0	0	0	0	0	0	0	0	0	0	0	0	0	0

Bit(s)	Name	Description
31:0	CS_ERR_CNT	Receive Checksum Error Count

5.19 Switch Controller

5.19.1 Registers

ESW Changes LOG

Revision	Date	Author	Change Log
0.1	2013/5/29	PeterCT WU	Initialization

Module name: ESW Base address: (+10110000h)

Address	Name	Width	Register Function
10110000	<u>ISR</u>	32	Interrupt Status
10110004	<u>IMR</u>	32	Interrupt Mask
10110008	<u>FCT0</u>	32	Flow Control Threshold 0
1011000C	<u>FCT1</u>	32	Flow Control Threshold 1
10110010	<u>PFC0</u>	32	Priority Flow Control 0
10110014	<u>PFC1</u>	32	Priority Flow Control 1
10110018	<u>PFC2</u>	32	Priority Flow Control 2
1011001C	<u>GQS0</u>	32	Global Queue Status 0
10110020	<u>GQS1</u>	32	Global Queue Status 1
10110024	<u>ATS</u>	32	Address Table Search
10110028	<u>ATS0</u>	32	Address Table Status 0
1011002C	<u>ATS1</u>	32	Address Table Status 1
10110030	<u>ATS2</u>	32	Address Table Status 2
10110034	<u>WMAD0</u>	32	WT_MAC_AD0
10110038	<u>WMAD1</u>	32	WT_MAC_AD1
1011003C	<u>WMAD2</u>	32	WT_MAC_AD2
10110040	<u>PVIDC0</u>	32	PVID Configuration 0
10110044	<u>PVIDC1</u>	32	PVID Configuration 1
10110048	<u>PVIDC2</u>	32	PVID Configuration 2
1011004C	<u>PVIDC3</u>	32	PVID Configuration 3
10110050	<u>VLANI0</u>	32	VLAN Identifier 0
10110054	<u>VLANI1</u>	32	VLAN Identifier 1
10110058	<u>VLANI2</u>	32	VLAN Identifier 2
1011005C	<u>VLANI3</u>	32	VLAN Identifier 3
10110060	<u>VLANI4</u>	32	VLAN Identifier 4
10110064	<u>VLANI5</u>	32	VLAN Identifier 5
10110068	<u>VLANI6</u>	32	VLAN Identifier 6
1011006C	<u>VLANI7</u>	32	VLAN Identifier 7
10110070	<u>VMSC0</u>	32	VLAN Member Port Configuration 0
10110074	<u>VMSC1</u>	32	VLAN Member Port Configuration 1
10110078	<u>VMSC2</u>	32	VLAN Member Port Configuration 2
1011007C	<u>VMSC3</u>	32	VLAN Member Port Configuration 3
10110080	<u>POA</u>	32	Port Ability Offset
10110084	<u>FPA</u>	32	Force Port4 - Port0 Ability
10110088	<u>PTS</u>	32	Port Status
1011008C	<u>SOCPC</u>	32	SoC Port Control
10110090	<u>POC0</u>	32	Port Control 0
10110094	<u>POC1</u>	32	Port Control 1
10110098	<u>POC2</u>	32	Port Control 2

1011009C	<u>SGC</u>	32	Switch Global Control
101100A0	<u>STRT</u>	32	Switch Reset
101100A4	<u>LEDP0</u>	32	LED Port0
101100A8	<u>LEDP1</u>	32	LED Port1
101100AC	<u>LEDP2</u>	32	LED Port2
101100B0	<u>LEDP3</u>	32	LED Port3
101100B4	<u>LEDP4</u>	32	LED Port4
101100B8	<u>WDTR</u>	32	Watch Dog Trigger Reset
101100BC	<u>DES</u>	32	Debug Signal
101100C0	<u>PCR0</u>	32	PHY Control Register 0
101100C4	<u>PCR1</u>	32	PHY Control Register 1
101100C8	<u>FPA1</u>	32	Force P5P6 Ability
101100CC	<u>FCT2</u>	32	Flow Control Threshold 2
101100D0	<u>QSS0</u>	32	Queue Status 0
101100D4	<u>QSS1</u>	32	Queue Status 1
101100D8	<u>DEC</u>	32	Debug Control
101100DC	<u>MTI</u>	32	Memory Test Information
101100E0	<u>PPC</u>	32	Packet Counter
101100E4	<u>SGC2</u>	32	Switch Global Control 2
101100E8	<u>P0PC</u>	32	Port 0 Packet Counter
101100EC	<u>P1PC</u>	32	Port 1 Packet Counter
101100F0	<u>P2PC</u>	32	Port 2 Packet Counter
101100F4	<u>P3PC</u>	32	Port 3 Packet Counter
101100F8	<u>P4PC</u>	32	Port 4 Packet Counter
101100FC	<u>P5PC</u>	32	Port 5 Packet Counter
10110100	<u>VUB0</u>	32	VLAN Untag Block 0
10110104	<u>VUB1</u>	32	VLAN Untag Block 1
10110108	<u>VUB2</u>	32	VLAN Untag Block 2
1011010C	<u>VUB3</u>	32	VLAN Untag Block 3
10110110	<u>BMU_CTRL</u>	32	BC/MC/UN Rate Limit Control
10110114	<u>BMU_LMT_NUM1</u>	32	BC/MC/UN Rate Limit Frame Number
10110118	<u>BMU_LMT_NUM2</u>	32	BC/MC/UN Rate Limit Frame Number
1011011C	<u>P01_ING_CTRL</u>	32	Port 0&1 Ingress Rate Limit Control
10110120	<u>P23_ING_CTRL</u>	32	Port 2&3 Ingress Rate Limit Control
10110124	<u>P45_ING_CTRL</u>	32	Port 4&5 Ingress Rate Limit Control
10110128	<u>P0_ING_THRESH</u>	32	Port 0 Ingress Rate Limit Threshold
1011012C	<u>P1_ING_THRESH</u>	32	Port 1 Ingress Rate Limit Threshold
10110130	<u>P2_ING_THRESH</u>	32	Port 2 Ingress Rate Limit Threshold
10110134	<u>P3_ING_THRESH</u>	32	Port 3 Ingress Rate Limit Threshold
10110138	<u>P4_ING_THRESH</u>	32	Port 4 Ingress Rate Limit Threshold
1011013C	<u>P5_ING_THRESH</u>	32	Port 5 Ingress Rate Limit Threshold
10110140	<u>P01_EG_CTRL</u>	32	Port 0/1 Egress Rate Limit Control
10110144	<u>P23_EG_CTRL</u>	32	Port 2/3 Egress Rate Limit Control
10110148	<u>P45_EG_CTRL</u>	32	Port 4/5 Egress Rate Limit Control
1011014C	<u>PCRI</u>	32	Packet Counter Recycle Indication
10110150	<u>P0TPC</u>	32	Port 0 TX Packet Counter

10110154	P1TPC	32	Port 1 TX Packet Counter
10110158	P2TPC	32	Port 2 TX Packet Counter
1011015C	P3TPC	32	Port 3 TX Packet Counter
10110160	P4TPC	32	Port 4 TX Packet Counter
10110164	P5TPC	32	Port 5 TX Packet Counter
10110168	LEDC	32	LED Control

10110000 **ISR** **Interrupt Status** **0000000**
0

Bit	31	30	29	28	27	26	25	24	23	22	21	20	19	18	17	16
Name	REV0		WATCHDOG1_TMR_EXPIRED	WATCHDOG0_TMR_EXPIRED	HAS_INTRUDER	PORT_ST_CHG	BC_STORM	MUST_DROP_LAN	GLOBAL_QUEUE_FULL			LAN_QUEUE_FULL_6	LAN_QUEUE_FULL_5	LAN_QUEUE_FULL_4	LAN_QUEUE_FULL_3	LAN_QUEUE_FULL_2
Type	RO		W1C	W1C	W1C	W1C	W1C	W1C	W1C			W1C	W1C	W1C	W1C	W1C
Reset	0	0	0	0	0	0	0	0	0			0	0	0	0	0
Bit	15	14	13	12	11	10	9	8	7	6	5	4	3	2	1	0
Name	LAN_QUEUE_FULL_1	LAN_QUEUE_FULL_0														
Type	W1C	W1C														
Reset	0	0														

Bit(s)	Name	Description
31:30	REV0	Reserved
29	WATCHDOG1_TMR_EXPIRED	P5 no transmit packet alert. This bit indicating that P5 don't transmit packet for 3 seconds when P5 need to transmit packet. Write one clear. [Note] This feature is only valid when port 5 Giga MAC is implemented.
28	WATCHDOG0_TMR_EXPIRED	Abnormal Alert This bit indicating that global queue block counts is less than buf_starvation_th for 3 seconds. Write one clear.
27	HAS_INTRUDER	Intruder Alert This bit indicating that an unsecured packet is coming into a secured port. Write one clear.
26	PORT_ST_CHG	Port status change Any port from link status change. Write one clear.
25	BC_STORM	BC storm The device is undergoing broadcast storm. Write one clear.
24	MUST_DROP_LAN	Queue exhausted The global queue is used up and all packets are dropped. Write one clear.
23	GLOBAL_QUEUE_FULL	Global Queue Full. Write one clear.
20	LAN_QUEUE_FULL_6	Port 6 out queue full. Write one clear. [Note]: This feature is only valid when port 5 Giga MAC is implemented.
19	LAN_QUEUE_FULL_5	Port 5 out queue full. Write one clear.
18	LAN_QUEUE_FULL_4	Port 4 out queue full. Write one clear.
17	LAN_QUEUE_FULL_3	Port 3 out queue full. Write one clear.

Bit(s)	Name	Description
16	LAN_QUE_FULL_2	Port 2 out queue full. Write one clear.
15	LAN_QUE_FULL_1	Port 1 out queue full. Write one clear.
14	LAN_QUE_FULL_0	Port 0 out queue full. Write one clear.

10110004 **IMR** **Interrupt Mask** **FFFFFF**
FF

Bit	31	30	29	28	27	26	25	24	23	22	21	20	19	18	17	16
Name			WATCHDOG1_TMR_EXPIRED	WATCHDOG0_TMR_EXPIRED	HAS_INTRUDER	PORT_ST_CHG	BC_STORM	MUST_DROP_LAN	GLOBAL_QUEUE_FULL	REV1		LAN_QUE_FULL_6	LAN_QUE_FULL_5	LAN_QUE_FULL_4	LAN_QUE_FULL_3	LAN_QUE_FULL_2
Type			RW	RW	RW	RW	RW	RW	RW	RW		RW	RW	RW	RW	RW
Reset			1	1	1	1	1	1	1	1	1	1	1	1	1	1
Bit	15	14	13	12	11	10	9	8	7	6	5	4	3	2	1	0
Name	LAN_QUE_FULL_1	LAN_QUE_FULL_0														
Type	RW	RW														
Reset	1	1														

Bit(s)	Name	Description
29	WATCHDOG1_TMR_EXPIRED	P5 no transmit packet alert. This bit indicating that P5 don't transmit packet for 3 seconds when P5 need to transmit packet. Write one clear. [Note]: This feature is only valid when port 5 Giga MAC is implemented.
28	WATCHDOG0_TMR_EXPIRED	Abnormal Alert This bit indicating that global queue block counts is less than buf_starvation_th for 3 seconds. Write one clear.
27	HAS_INTRUDER	Intruder Alert This bit indicating that an unsecured packet is coming into a secured port. Write one clear.
26	PORT_ST_CHG	Port status change Any port from link status change. Write one clear.
25	BC_STORM	BC storm The device is undergoing broadcast storm. Write one clear.
24	MUST_DROP_LAN	Queue exhausted The global queue is used up and all packets are dropped. Write one clear.
23	GLOBAL_QUEUE_FULL	Global Queue Full. Write one clear.
22:21	REV1	Port 6 out queue full. Write one clear. [Note]: This feature is only valid when port 5 Giga MAC is implemented.
20	LAN_QUE_FULL_6	Port 6 out queue full. Write one clear. [Note]: This feature is only valid when port 5 Giga MAC is implemented.
19	LAN_QUE_FULL_5	Port 5 out queue full. Write one clear.
18	LAN_QUE_FULL_4	Port 4 out queue full. Write one clear.
17	LAN_QUE_FULL_3	Port 3 out queue full. Write one clear.
16	LAN_QUE_FULL_2	Port 2 out queue full. Write one clear.
15	LAN_QUE_FULL_1	Port 1 out queue full. Write one clear.

Bit(s)	Name	Description
14	LAN_QUE_FULL_0	Port 0 out queue full. Write one clear.

10110008 **FCT0** **Flow Control Threshold 0** **FFC86E**
5A

Bit	31	30	29	28	27	26	25	24	23	22	21	20	19	18	17	16
Name	FC_RLS_TH								FC_SET_TH							
Type	RW								RW							
Reset	1	1	1	1	1	1	1	1	1	1	0	0	1	0	0	0
Bit	15	14	13	12	11	10	9	8	7	6	5	4	3	2	1	0
Name	DRO_RLS_TH								DROP_SET_TH							
Type	RW								RW							
Reset	0	1	1	0	1	1	1	0	0	1	0	1	1	0	1	0

Bit(s)	Name	Description
31:24	FC_RLS_TH	Flow Control Release Threshold Flow control will be disabled when the global queue block counts is greater than the release threshold
23:16	FC_SET_TH	Flow Control Set Threshold Flow control will be enabled when the global queue block counts is less than the set threshold
15:8	DRO_RLS_TH	Drop Release Threshold Switch will stop dropping packets when the global queue block counts is greater than the drop-release threshold
7:0	DROP_SET_TH	Drop Set Threshold Switch will start dropping packets when the global queue block counts is less than the drop-set threshold.

1011000C **FCT1** **Flow Control Threshold 1** **0000001**
4

Bit	31	30	29	28	27	26	25	24	23	22	21	20	19	18	17	16
Name																
Type																
Reset																
Bit	15	14	13	12	11	10	9	8	7	6	5	4	3	2	1	0
Name									PORT_TH							
Type									RW							
Reset									0	0	0	1	0	1	0	0

Bit(s)	Name	Description
7:0	PORT_TH	Per Port Output Threshold When the global queue reaches the flow control or drop threshold on register FCT0, per port output threshold will be checked to enable flow-control or packet-dop depending on per queue minimum reserved blocks of the register PFC2.

10110010 **PFC0** **Priority Flow Control 0** **0F00000**
0

Bit	31	30	29	28	27	26	25	24	23	22	21	20	19	18	17	16
Name					MTCC_LMT					TURN_OFF_FC						
Type					RW					RW						
Reset					1	1	1	1		0	0	0	0	0	0	0
Bit	15	14	13	12	11	10	9	8	7	6	5	4	3	2	1	0
Name	VO_NUM				CL_NUM				BE_NUM				BK_NUM			
Type	RW				RW				RW				RW			

Reset	0	0	0	0	0	0	0	0	0	0	0	0	0	0	0	0
--------------	---	---	---	---	---	---	---	---	---	---	---	---	---	---	---	---

Bit(s)	Name	Description
27:24	MTCC_LMT	MTCC LIMIT The maximum Back-off count limit to drop excessive collision packets.
22:16	TURN_OFF_FC	Turn off FC When Receiving High Packet Auto-turn-off FC when the programmed ports receive one of the highest priority packet. 0: Disable 1: Enable
15:12	VO_NUM	The proportional number of WRR for Voice Queue After transmit exactly the number of packets then proceed to next queue. If equal to 0, only this queue is forced to the strict priority mode
11:8	CL_NUM	The proportional number of WRR for Control-Load Queue After transmit exactly the number of packet then proceed to next queue.
7:4	BE_NUM	The proportional number of WRR for Best-Effort Queue After transmit exactly the number of packet then proceed to next queue.
3:0	BK_NUM	The proportional number of WRR for Background Queue After transmit exactly the number of packet then proceed to next queue.

10110014 PFC1 Priority Flow Control 1 0000155 5

Bit	31	30	29	28	27	26	25	24	23	22	21	20	19	18	17	16
Name	CP U_ US E_ Q1_ EN	EN_TOS							IGM P_ T O_ CP U	EN_VLAN						
Type	RW	RW							RW	RW						
Reset	0	0	0	0	0	0	0	0	0	0	0	0	0	0	0	0
Bit	15	14	13	12	11	10	9	8	7	6	5	4	3	2	1	0
Name	PRI ORI TY_ OP TION		PORT_PRI 6	PORT_PRI 5	PORT_PRI 4	PORT_PRI 3	PORT_PRI 2	PORT_PRI 1	PORT_PRI 0							
Type	RW		RW	RW	RW	RW	RW	RW	RW							
Reset	0		0	1	0	1	0	1	0	1	0	1	0	1	0	1

Bit(s)	Name	Description
31	CPU_USE_Q1_EN	CPU Port only use q1 enable 0: default priority resolution 1: packets forwarded to CPU port uses Best-Effor Queue
30:24	EN_TOS	Port6 ~ port0 TOS_en. Check TOS field of IP packets for priority resolution. [Note] Port 5 function is only vliad when port 5 Giga MAC is implemented 0: Disable 1: Enable
23	IGMP_TO_CPU	IGMP forward to CPU enable 0: IGMP message will be floode to all ports 1: IGMP message will be forwarded to CPU port only.
22:16	EN_VLAN	Enable per port VLAN-tag VID membership and priority tag check. [Note] Port 5 function is only vliad when port 5 Giga MAC is implemented 0: disable. 1: enable
15	PRIORITY_OPTION	Priority Resolution Option 0: 802.1p -> TOS -> Per port 1: TOS -> 802.1p -> Per port

Bit(s)	Name	Description
13:12	PORT_PRI6	Port priority By setting this register to assign per port's default priority queue.
11:10	PORT_PRI5	Port priority By setting this register to assign per port's default priority queue. [Note] This feature is only valid when port 6 Giga MAC is implemented
9:8	PORT_PRI4	Port priority By setting this register to assign per port's default priority queue.
7:6	PORT_PRI3	Port priority By setting this register to assign per port's default priority queue.
5:4	PORT_PRI2	Port priority By setting this register to assign per port's default priority queue.
3:2	PORT_PRI1	Port priority By setting this register to assign per port's default priority queue.
1:0	PORT_PRI0	Port priority By setting this register to assign per port's default priority queue.

10110018 PFC2 Priority Flow Control 2 0303030

3

Bit	31	30	29	28	27	26	25	24	23	22	21	20	19	18	17	16
Name	PRI_TH_VO								PRI_TH_CL							
Type	RW								RW							
Reset	0	0	0	0	0	0	1	1	0	0	0	0	0	0	1	1
Bit	15	14	13	12	11	10	9	8	7	6	5	4	3	2	1	0
Name	PRI_TH_BE								PRI_TH_BK							
Type	RW								RW							
Reset	0	0	0	0	0	0	1	1	0	0	0	0	0	0	1	1

Bit(s)	Name	Description
31:24	PRI_TH_VO	Voice Threshold (Highest Priority) The minimum reserved packet block count which outout queue can store when the flow-control /drop threshold of registers FTC0 and FCT1 is reached. If the queued blocks exceed the threshold, the incoming packet will be paused or dropped.
23:16	PRI_TH_CL	Control Load Threshold The minimum reserved packet block count which outout queue can store when the flow-control/drop threshold of registers FTC0 and FCT1 is reached. If the queued blocks exceed the threshold, the incoming packet will be paused or dropped.
15:8	PRI_TH_BE	Best Effort threshold The minimum reserved packet block count which outout queue can store when the flow-control/drop threshold of registers FTC0 and FCT1 is reached. If the queued blocks exceed the threshold, the incoming packet will be paused or dropped.
7:0	PRI_TH_BK	Background Threshold (Lowest Priority) The minimum reserved packet block count which outout queue can store when the flow-control/drop threshold of registers FTC0 and FCT1 is reached. If the queued blocks exceed the threshold, the incoming packet will be paused or dropped.

1011001C QQS0 Global Queue Status 0 FA41016

E

Bit	31	30	29	28	27	26	25	24	23	22	21	20	19	18	17	16
Name	PRI7_QUE		PRI6_QUE		PRI5_QUE		PRI4_QUE		PRI3_QUE		PRI2_QUE		PRI1_QUE		PRI0_QUE	
Type	RW		RW		RW		RW		RW		RW		RW		RW	
Reset	1	1	1	1	1	0	1	0	0	1	0	0	0	0	0	1

Bit	15	14	13	12	11	10	9	8	7	6	5	4	3	2	1	0
Name	EMPTY_CNT															
Type	RO															
Reset								1	0	1	1	0	1	1	1	0

Bit(s)	Name	Description
31:30	PRI7_QUE	Queue mapping for Priority Tag #7
29:28	PRI6_QUE	Queue mapping for Priority Tag #6
27:26	PRI5_QUE	Queue mapping for Priority Tag #5
25:24	PRI4_QUE	Queue mapping for Priority Tag #4
23:22	PRI3_QUE	Queue mapping for Priority Tag #3
21:20	PRI2_QUE	Queue mapping for Priority Tag #2
19:18	PRI1_QUE	Queue mapping for Priority Tag #1
17:16	PRI0_QUE	Queue mapping for Priority Tag #0
8:0	EMPTY_CNT	Global Queue Block Counts This field indicates the number of block count left in the global free queue.

10110020 QQS1 Global Queue Status 1 0000000
0

Bit	31	30	29	28	27	26	25	24	23	22	21	20	19	18	17	16
Name	OUTQUE_FULL_VO								OUTQUE_FULL_CL							
Type	RO															
Reset	0	0	0	0	0	0	0	0	0	0	0	0	0	0	0	0
Bit	15	14	13	12	11	10	9	8	7	6	5	4	3	2	1	0
Name	OUTQUE_FULL_BE								OUTQUE_FULL_BK							
Type	RO															
Reset	0	0	0	0	0	0	0	0	0	0	0	0	0	0	0	0

Bit(s)	Name	Description
31:24	OUTQUE_FULL_VO	Congested Voice Queue The corresponding queue is congested
23:16	OUTQUE_FULL_CL	Congested Control Load Queue The corresponding queue is congested
15:8	OUTQUE_FULL_BE	Congested Best Effort Queue The corresponding queue is congested
7:0	OUTQUE_FULL_BK	Congested Background Queue The corresponding queue is congested

10110024 ATS Address Table Search 0000000
4

Bit	31	30	29	28	27	26	25	24	23	22	21	20	19	18	17	16
Name																
Type																
Reset																
Bit	15	14	13	12	11	10	9	8	7	6	5	4	3	2	1	0
Name														AT_LK UP_IDL E	SE AR CH_NX T_A DDR	BE GIN _SE AR CH _A DDR
Type														RO	W1 C	W1 C
Reset														1	0	0

Bit(s)	Name	Description
2	AT_LKUP_IDLE	Address Lookup Idle This field indicates that Adres Table engine is in IDLE state.
1	SEARCH_NXT_ADDR	Search For The Next Address (Self_Clear)
0	BEGIN_SEARCH_ADDR	Start Searching The Address Table (Self_Clear)

10110028 AT_S0 Address Table Status 0 0000000
0

Bit	31	30	29	28	27	26	25	24	23	22	21	20	19	18	17	16	
Name	HASH_ADD_LU											R_PORT_MAP[6:4]					
Type	RO											RO					
Reset	0	0	0	0	0	0	0	0	0	0				0	0	0	
Bit	15	14	13	12	11	10	9	8	7	6	5	4	3	2	1	0	
Name	R_PORT_MAP[3:0]					R_VLD				R_AGE_FIELD					R_MC_INGRESS	AT_TABLE_END	SEARCH_RDY
Type	RO					RO				RO					RO	RO	RC
Reset	0	0	0	0		0	0	0	0	0	0	0		0	0	0	

Bit(s)	Name	Description
31:22	HASH_ADD_LU	Address table lookup address
18:12	R_PORT_MAP	Port map The MAC existing in the bit =1.
10:7	R_VLD	VLAN index
6:4	R_AGE_FIELD	Aging field
2	R_MC_INGRESS	MC Ingress
1	AT_TABLE_END	Search to the end of address table
0	SEARCH_RDY	Data is ready (read clear)

1011002C AT_S1 Address Table Status 1 0000000
0

Bit	31	30	29	28	27	26	25	24	23	22	21	20	19	18	17	16
Name																
Type																
Reset																
Bit	15	14	13	12	11	10	9	8	7	6	5	4	3	2	1	0
Name	MAC_AD_SER0															
Type	RO															
Reset	0	0	0	0	0	0	0	0	0	0	0	0	0	0	0	0

Bit(s)	Name	Description
15:0	MAC_AD_SER0	Read MAC Address [15:0]

10110030 AT_S2 Address Table Status 2 0000000
0

Bit	31	30	29	28	27	26	25	24	23	22	21	20	19	18	17	16
Name	MAC_AD_SER0[31:16]															
Type	RO															
Reset	0	0	0	0	0	0	0	0	0	0	0	0	0	0	0	0

Bit	15	14	13	12	11	10	9	8	7	6	5	4	3	2	1	0
Name	MAC_AD_SER0[15:0]															
Type	RO															
Reset	0	0	0	0	0	0	0	0	0	0	0	0	0	0	0	0

Bit(s)	Name	Description
31:0	MAC_AD_SER0	Read MAC Address [31:16]

10110034 **WMAD0** WT_MAC_AD0 0008000
0

Bit	31	30	29	28	27	26	25	24	23	22	21	20	19	18	17	16
Name	HASH_ADD_LU											AT_CFG_IDLE	W_PORT_MAP[6:4]			
Type	RO											RO	RW			
Reset	0	0	0	0	0	0	0	0	0	0	0	0	1	0	0	0
Bit	15	14	13	12	11	10	9	8	7	6	5	4	3	2	1	0
Name	W_PORT_MAP[3:0]					W_INDEX				W_AGE_FIELD			SA_FILTER	W_MC_INGRESS	W_MAC_DONE	W_MAC_CMD
Type	RW					RW				RW			RW	RW	RO	WO
Reset	0	0	0	0		0	0	0	0	0	0	0	0	0	0	0

Bit(s)	Name	Description
31:22	HASH_ADD_LU	Address table configuration address
19	AT_CFG_IDLE	Address Table Configuration SM IDLE
18:12	W_PORT_MAP	Write Port map
10:7	W_INDEX	VLAN index 0: VLAN 0 1-14: ... 15: VLAN 15
6:4	W_AGE_FIELD	Write Aging field 3'b111: static address, 3'b001 - 3'b110: the entry is valid and will be aged out 2'b000: default, entry is invalid
3	SA_FILTER	SA_FILTER 0: default 1: The corresponding packet will be dropped when the SA is matched
2	W_MC_INGRESS	Write MC Ingress
1	W_MAC_DONE	MAC Write Done 0: default 1: MAC address write OK (read clear)
0	W_MAC_CMD	MAC Address write Command 0: default 1: the MAC write data is ready and write to MAC table now(self_clear)

10110038 **WMAD1** WT_MAC_AD1 0000000
0

Bit	31	30	29	28	27	26	25	24	23	22	21	20	19	18	17	16
Name																
Type																
Reset																
Bit	15	14	13	12	11	10	9	8	7	6	5	4	3	2	1	0

Name	W_MAC_15_0															
Type	RW															
Reset	0	0	0	0	0	0	0	0	0	0	0	0	0	0	0	0

Bit(s)	Name	Description
15:0	W_MAC_15_0	Write MAC Address[15:0]

1011003C WMAD2 WT_MAC_AD2 0000000
0

Bit	31	30	29	28	27	26	25	24	23	22	21	20	19	18	17	16
Name	W_MAC_47_16[31:16]															
Type	RW															
Reset	0	0	0	0	0	0	0	0	0	0	0	0	0	0	0	0
Bit	15	14	13	12	11	10	9	8	7	6	5	4	3	2	1	0
Name	W_MAC_47_16[15:0]															
Type	RW															
Reset	0	0	0	0	0	0	0	0	0	0	0	0	0	0	0	0

Bit(s)	Name	Description
31:0	W_MAC_47_16	Write MAC Address[47:16]

10110040 PVIDC0 PVID Configuration 0 0000100
1

Bit	31	30	29	28	27	26	25	24	23	22	21	20	19	18	17	16
Name	P1_PVID[11:4]															
Type	RW															
Reset	0	0	0	0	0	0	0	0	0	0	0	0	0	0	0	0
Bit	15	14	13	12	11	10	9	8	7	6	5	4	3	2	1	0
Name	P1_PVID[3:0]				P0_PVID											
Type	RW				RW											
Reset	0	0	0	1	0	0	0	0	0	0	0	0	0	0	0	1

Bit(s)	Name	Description
23:12	P1_PVID	Port1 PVID Setting
11:0	P0_PVID	Port0 PVID Setting

10110044 PVIDC1 PVID Configuration 1 0000100
1

Bit	31	30	29	28	27	26	25	24	23	22	21	20	19	18	17	16
Name	P3_PVID[11:4]															
Type	RW															
Reset	0	0	0	0	0	0	0	0	0	0	0	0	0	0	0	0
Bit	15	14	13	12	11	10	9	8	7	6	5	4	3	2	1	0
Name	P3_PVID[3:0]				P2_PVID											
Type	RW				RW											
Reset	0	0	0	1	0	0	0	0	0	0	0	0	0	0	0	1

Bit(s)	Name	Description
23:12	P3_PVID	Port3 PVID Setting
11:0	P2_PVID	Port2 PVID Setting

10110048 PVIDC2 PVID Configuration 2 0000100
1

Bit	31	30	29	28	27	26	25	24	23	22	21	20	19	18	17	16
Name									P5_PVID[11:4]							
Type									RW							
Reset									0	0	0	0	0	0	0	0
Bit	15	14	13	12	11	10	9	8	7	6	5	4	3	2	1	0
Name	P5_PVID[3:0]				P4_PVID											
Type	RW				RW											
Reset	0	0	0	1	0	0	0	0	0	0	0	0	0	0	0	1

Bit(s)	Name	Description
23:12	P5_PVID	Port5 PVID Setting [Note] This feature is only valid when port 5 Giga MAC is implemented.
11:0	P4_PVID	Port4 PVID Setting

1011004C **PVIDC3** **PVID Configuration 3** **7502000**
1

Bit	31	30	29	28	27	26	25	24	23	22	21	20	19	18	17	16			
Name	QUE3_PRIT				QUE2_PRIT				QUE1_PRIT				QUE0_PRIT						
Type	RW				RW				RW				RW						
Reset	1	1	1	1	1	0	1	1	0	0	0	0	0	0	1	0			
Bit	15	14	13	12	11	10	9	8	7	6	5	4	3	2	1	0			
Name									P6_PVID										
Type									RW										
Reset									0	0	0	0	0	0	0	0	0	0	1

Bit(s)	Name	Description
30:28	QUE3_PRIT	Priority Tag Egress Mapping for Voice Queue#3
26:24	QUE2_PRIT	Priority Tag Egress Mapping for Control Load Queue#2
22:20	QUE1_PRIT	Priority Tag Egress Mapping for Best Effort Queue#1
18:16	QUE0_PRIT	Priority Tag Egress Mapping for Back Ground Queue#0
11:0	P6_PVID	Port6 PVID Setting

10110050 **VLANI0** **VLAN Identifier 0** **0000200**
1

Bit	31	30	29	28	27	26	25	24	23	22	21	20	19	18	17	16
Name									VID1[11:4]							
Type									RW							
Reset									0	0	0	0	0	0	0	0
Bit	15	14	13	12	11	10	9	8	7	6	5	4	3	2	1	0
Name	VID1[3:0]				VID0											
Type	RW				RW											
Reset	0	0	1	0	0	0	0	0	0	0	0	0	0	0	0	1

Bit(s)	Name	Description
23:12	VID1	VLAN Field Identifier for VLAN 1
11:0	VID0	VLAN Field Identifier for VLAN 0

10110054 **VLANI1** **VLAN Identifier 1** **0000400**
3

Bit	31	30	29	28	27	26	25	24	23	22	21	20	19	18	17	16
Name									VID3[11:4]							
Type									RW							
Reset									0	0	0	0	0	0	0	0
Bit	15	14	13	12	11	10	9	8	7	6	5	4	3	2	1	0
Name	VID3[3:0]				VID2											

Type	RW							RW									
Reset	0	1	0	0	0	0	0	0	0	0	0	0	0	0	0	1	1

Bit(s)	Name	Description
23:12	VID3	VLAN Field Identifier for VLAN 3
11:0	VID2	VLAN Field Identifier for VLAN 2

10110058 **VLANI2** VLAN Identifier 2 0000600
5

Bit	31	30	29	28	27	26	25	24	23	22	21	20	19	18	17	16	
Name									VID5[11:4]								
Type									RW								
Reset									0	0	0	0	0	0	0	0	
Bit	15	14	13	12	11	10	9	8	7	6	5	4	3	2	1	0	
Name	VID5[3:0]				VID4												
Type	RW				RW												
Reset	0	1	1	0	0	0	0	0	0	0	0	0	0	0	1	0	1

Bit(s)	Name	Description
23:12	VID5	VLAN Field Identifier for VLAN 5
11:0	VID4	VLAN Field Identifier for VLAN 4

1011005C **VLANI3** VLAN Identifier 3 0000800
7

Bit	31	30	29	28	27	26	25	24	23	22	21	20	19	18	17	16	
Name									VID7[11:4]								
Type									RW								
Reset									0	0	0	0	0	0	0	0	
Bit	15	14	13	12	11	10	9	8	7	6	5	4	3	2	1	0	
Name	VID7[3:0]				VID6												
Type	RW				RW												
Reset	1	0	0	0	0	0	0	0	0	0	0	0	0	0	1	1	1

Bit(s)	Name	Description
23:12	VID7	VLAN Field Identifier for VLAN 7
11:0	VID6	VLAN Field Identifier for VLAN 6

10110060 **VLANI4** VLAN Identifier 4 0000A00
9

Bit	31	30	29	28	27	26	25	24	23	22	21	20	19	18	17	16
Name									VID9[11:4]							
Type									RW							
Reset									0	0	0	0	0	0	0	0
Bit	15	14	13	12	11	10	9	8	7	6	5	4	3	2	1	0
Name	VID9[3:0]				VID8											
Type	RW				RW											
Reset	1	0	1	0	0	0	0	0	0	0	0	0	1	0	0	1

Bit(s)	Name	Description
23:12	VID9	VLAN Field Identifier for VLAN 9
11:0	VID8	VLAN Field Identifier for VLAN 8

10110064 **VLANI5** **VLAN Identifier 5** **0000C00**
B

Bit	31	30	29	28	27	26	25	24	23	22	21	20	19	18	17	16
Name									VID11[11:4]							
Type									RW							
Reset									0	0	0	0	0	0	0	0
Bit	15	14	13	12	11	10	9	8	7	6	5	4	3	2	1	0
Name	VID11[3:0]				VID10											
Type	RW				RW											
Reset	1	1	0	0	0	0	0	0	0	0	0	0	1	0	1	1

Bit(s)	Name	Description
23:12	VID11	VLAN Field Identifier for VLAN 11
11:0	VID10	VLAN Field Identifier for VLAN 10

10110068 **VLANI6** **VLAN Identifier 6** **0000E00**
D

Bit	31	30	29	28	27	26	25	24	23	22	21	20	19	18	17	16
Name									VID13[11:4]							
Type									RW							
Reset									0	0	0	0	0	0	0	0
Bit	15	14	13	12	11	10	9	8	7	6	5	4	3	2	1	0
Name	VID13[3:0]				VID12											
Type	RW				RW											
Reset	1	1	1	0	0	0	0	0	0	0	0	0	1	1	0	1

Bit(s)	Name	Description
23:12	VID13	VLAN Field Identifier for VLAN 13
11:0	VID12	VLAN Field Identifier for VLAN 12

1011006C **VLANI7** **VLAN Identifier 7** **0001000**
F

Bit	31	30	29	28	27	26	25	24	23	22	21	20	19	18	17	16
Name									VID15[11:4]							
Type									RW							
Reset									0	0	0	0	0	0	0	1
Bit	15	14	13	12	11	10	9	8	7	6	5	4	3	2	1	0
Name	VID15[3:0]				VID14											
Type	RW				RW											
Reset	0	0	0	0	0	0	0	0	0	0	0	0	1	1	1	1

Bit(s)	Name	Description
23:12	VID15	VLAN Field Identifier for VLAN 15
11:0	VID14	VLAN Field Identifier for VLAN 14

10110070 **VMSCO** **VLAN Member Port Configuration 0** **FFFFFF**
FF

Bit	31	30	29	28	27	26	25	24	23	22	21	20	19	18	17	16
Name	VLAN_MEMSET_3								VLAN_MEMSET_2							
Type	RW								RW							
Reset	1	1	1	1	1	1	1	1	1	1	1	1	1	1	1	1
Bit	15	14	13	12	11	10	9	8	7	6	5	4	3	2	1	0
Name	VLAN_MEMSET_1								VLAN_MEMSET_0							
Type	RW								RW							
Reset	1	1	1	1	1	1	1	1	1	1	1	1	1	1	1	1

Bit(s)	Name	Description
31:24	VLAN_MEMSET_3	VLAN 3 Member Port
23:16	VLAN_MEMSET_2	VLAN 2 Member Port
15:8	VLAN_MEMSET_1	VLAN 1 Member Port
7:0	VLAN_MEMSET_0	VLAN 0 Member Port

10110074 VMSC1 VLAN Member Port Configuration 1 FFFFFF
FF

Bit	31	30	29	28	27	26	25	24	23	22	21	20	19	18	17	16
Name	VLAN_MEMSET_7								VLAN_MEMSET_6							
Type	RW								RW							
Reset	1	1	1	1	1	1	1	1	1	1	1	1	1	1	1	1
Bit	15	14	13	12	11	10	9	8	7	6	5	4	3	2	1	0
Name	VLAN_MEMSET_5								VLAN_MEMSET_4							
Type	RW								RW							
Reset	1	1	1	1	1	1	1	1	1	1	1	1	1	1	1	1

Bit(s)	Name	Description
31:24	VLAN_MEMSET_7	VLAN 7 Member Port
23:16	VLAN_MEMSET_6	VLAN 6 Member Port
15:8	VLAN_MEMSET_5	VLAN 5 Member Port
7:0	VLAN_MEMSET_4	VLAN 4 Member Port

10110078 VMSC2 VLAN Member Port Configuration 2 FFFFFF
FF

Bit	31	30	29	28	27	26	25	24	23	22	21	20	19	18	17	16
Name	VLAN_MEMSET_11								VLAN_MEMSET_10							
Type	RW								RW							
Reset	1	1	1	1	1	1	1	1	1	1	1	1	1	1	1	1
Bit	15	14	13	12	11	10	9	8	7	6	5	4	3	2	1	0
Name	VLAN_MEMSET_9								VLAN_MEMSET_8							
Type	RW								RW							
Reset	1	1	1	1	1	1	1	1	1	1	1	1	1	1	1	1

Bit(s)	Name	Description
31:24	VLAN_MEMSET_11	VLAN 11 Member Port
23:16	VLAN_MEMSET_10	VLAN 10 Member Port
15:8	VLAN_MEMSET_9	VLAN 9 Member Port
7:0	VLAN_MEMSET_8	VLAN 8 Member Port

1011007C VMSC3 VLAN Member Port Configuration 3 FFFFFF
FF

Bit	31	30	29	28	27	26	25	24	23	22	21	20	19	18	17	16
Name	VLAN_MEMSET_15								VLAN_MEMSET_14							
Type	RW								RW							
Reset	1	1	1	1	1	1	1	1	1	1	1	1	1	1	1	1
Bit	15	14	13	12	11	10	9	8	7	6	5	4	3	2	1	0
Name	VLAN_MEMSET_13								VLAN_MEMSET_12							
Type	RW								RW							
Reset	1	1	1	1	1	1	1	1	1	1	1	1	1	1	1	1

Bit(s)	Name	Description
--------	------	-------------

Bit(s)	Name	Description
31:24	VLAN_MEMSET_15	VLAN 15 Member Port
23:16	VLAN_MEMSET_14	VLAN 14 Member Port
15:8	VLAN_MEMSET_13	VLAN 13 Member Port
7:0	VLAN_MEMSET_12	VLAN 12 Member Port

10110080 POA Port Ability Offset **0000000**
0

Bit	31	30	29	28	27	26	25	24	23	22	21	20	19	18	17	16	
Name	G1_LINK	G0_LINK	LINK				G1_TXC		G0_TXC		XFC						
Type	RO	RO	RO				RO		RO		RO						
Reset	0	0	0	0	0	0	0	0	0	0	0	0	0	0	0	0	
Bit	15	14	13	12	11	10	9	8	7	6	5	4	3	2	1	0	
Name	DUPLEX							G1_SPD		G0_SPD		SPEED					
Type	RO							RO		RO		RO					
Reset	0	0	0	0	0	0	0	0	0	0	0	0	0	0	0	0	

Bit(s)	Name	Description
31	G1_LINK	Port 6 Link Status 1: Link up 0: Link down
30	G0_LINK	Port 5 Link Status [Note] This feature is only valid when port 5 giga MAC is implemented. 1: Link up 0: Link down
29:25	LINK	Port 4 ~ port0 Link Status 1: Link up 0: Link down
24:23	G1_TXC	Flow Control Status fo Port6 The flow control capability status bit after Auto-negotiation or force mode. 1xb: full duplex and tx flow control ON x1b: full duplex and rx flow control ON 00b: flow control off
22:21	G0_TXC	Flow Control Status fo Port5 The flow control capability status bit after Auto-negotiation or force mode. [Note] This feature is only valid when port 5 giga MAC is implemented. 1xb: full duplex and tx flow control ON x1b: full duplex and rx flow control ON 00b: flow control off
20:16	XFC	Flow Control Status of port 0 ~ 4 The flow control capability status bit after Auto-negotiation or force mode. 0: flow control off 1: full duplex and 802.3x flow control ON (after AN or forced)
15:9	DUPLEX	Port6 ~ port0 Duplex Mode [Note]: Port5 functon is only valid when port 5 Giga MAC is implemented. 0: half duplex 1: full duplex
8:7	G1_SPD	MIl port 6 Speed:Mode 10: 1000M 01: 100M 00: 10M
6:5	G0_SPD	MIl port 5 Speed:Mode [Note] This feature is only valid when port 5 Giga MAC is implemented 10: 1000M 01: 100M 00: 10M

Bit(s)	Name	Description
4:0	SPEED	Port4 ~ port0 Speed Mode 0: 10M 1: 100M

10110084 **FPA** **Force Port4 - Port0 Ability** **0000000**
0

Bit	31	30	29	28	27	26	25	24	23	22	21	20	19	18	17	16
Name	FORCE_MODE				FORCE_LINK					FORCE_XFC						
Type	RW				RW					RW						
Reset	0	0	0	0	0	0	0	0	0	0	0	0	0	0	0	0
Bit	15	14	13	12	11	10	9	8	7	6	5	4	3	2	1	0
Name				FORCE_DPX							XTAL_COMP	FORCE_SPD				
Type				RW							RW	RW				
Reset				0	0	0	0	0			0	0	0	0	0	0

Bit(s)	Name	Description
31:27	FORCE_MODE	Port4 ~ port 0 force mode 0: default 1: force mode. Auto-negotiation status is ignored. All the port ability are forced according to the following fields of the register FPA.
26:22	FORCE_LINK	Port 4 ~ port 0 PHY Link This field is valid only FORCE_MDOE is set. The final resolution is reported to POA register. 1: Link up 0: Link down
20:16	FORCE_XFC	Port 4 ~ port 0 Flow control of PHY port This field is valid only FORCE_MDOE is set. The final resolution is reported to POA register. 0: default OFF 1: 802.3x flow control ON
12:8	FORCE_DPX	Flow Control Status of port 0 ~ 4 The flow control capability status bit after Auto-negotiation or force mode. 0: flow control off 1: full duplex and 802.3x flow control ON (after AN or forced)
5	XTAL_COMP	Crystal rate compensation 0: Disable 1: When the switch has transmitted 20000 bytes, the switch will compensate for the loss of crystal rate.
4:0	FORCE_SPD	Port4 ~ port0 Speed: This field is valid only FORCE_MDOE is set. The final resolution is reported to POA register. 1: 100M 0: 10M

10110088 **PTS** **Port Status** **0000000**
0

Bit	31	30	29	28	27	26	25	24	23	22	21	20	19	18	17	16
Name																
Type																
Reset																
Bit	15	14	13	12	11	10	9	8	7	6	5	4	3	2	1	0
Name							G1_TX_C_S TAT	G0_TX_C_S TAT		SECURED_ST						

							US	US								
Type							RO	RO								RO
Reset							0	0								0 0 0 0 0 0 0

Bit(s)	Name	Description
9	G1_TXC_STATUS	Port 6 TXC status 0: no alert 1: error, no TXC
8	G0_TXC_STATUS	Port 5 TXC status [Note] This feature is only valid when port 5 Giga MAC is implemented. 0: no alert 1: error, no TXC
6:0	SECURED_ST	Security Status 0: no alert 1: has intruder coming if turn on the SA_secured mode, read clear

1011008C SOCPC SoC Port Control 027F7F7 F

Bit	31	30	29	28	27	26	25	24	23	22	21	20	19	18	17	16
Name							CR C_P AD DIN G	CPU_SELE CTION	DISBC2CPU							
Type							RW	RW	RW							
Reset							1	0	0	1	1	1	1	1	1	1
Bit	15	14	13	12	11	10	9	8	7	6	5	4	3	2	1	0
Name	DISMC2CPU							DISUN2CPU								
Type	RW							RW								
Reset		1	1	1	1	1	1	1		1	1	1	1	1	1	1

Bit(s)	Name	Description
25	CRC_PADDING	CRC padding from CPU If this bit is set , all packets from CPU don't need to append CRC and the outgoing LAN/WAN port will calculate and append CRC. 0: packets from CPU need CRC appending 1: packets from CPU without CRC appending
24:23	CPU_SELECTION	CPU Selection 00b: Port 6 01b: Port 0 10b: Port 4 11b: Port 5
22:16	DISBC2CPU	Disable BC to CPU When this bit = 1, BC frames from the corresponding port will not be forward to CPU. [Note] Port5 function is only valid when port 5 Giga MAC is implemented. 0: Includes CPU port. 1: Excludes CPU port
14:8	DISMC2CPU	Disable MC to CPU When this bit =1, MC frames from the corresponding port will not forward to CPU. [Note] Port5 function is only valid when port 5 Giga MAC is implemented. 0: Includes CPU port. 1: Excludes CPU port
6:0	DISUN2CPU	Disable UN to CPU When this bit =1, Unknown frames from the corresponding port will not forward to CPU. [Note] Port5 function is only valid when port 5 Giga MAC is implemented. 0: Includes CPU port. 1: Excludes CPU port

10110090 POC0

Port Control 0

3F807F7
F

Bit	31	30	29	28	27	26	25	24	23	22	21	20	19	18	17	16
Name	HASH_ADDR_SHIFT		DIS_GMII_PORT_1	DIS_GMII_PORT_0	DIS_PORT					DISRMC2_CPU						
Type	RW		RW	RW	RW					RW						
Reset	0	0	1	1	1	1	1	1	1	0	0	0	0	0	0	0
Bit	15	14	13	12	11	10	9	8	7	6	5	4	3	2	1	0
Name			EN_FC						MAC_FCP_OPTION	EN_BP						
Type			RW						RW	RW						
Reset			1	1	1	1	1	1	1	0	1	1	1	1	1	1

Bit(s)	Name	Description
31:30	HASH_ADDR_SHIFT	Address table hashing algorithm option for member set index
29	DIS_GMII_PORT_1	Disable port 6 0: port enable 1: port disable
28	DIS_GMII_PORT_0	Disable port 5 [Note] This feature is only valid when port 5 Giga MAC is implemented. 0: port enable 1: port disable
27:23	DIS_PORT	Disable phy port 0: port enable 1: port disable
22:16	DISRMC2_CPU	Unknown Reserved Multicast Frame Excludes CPU [Note] Port5 function is only valid when port 5 Giga MAC is implemented. 0: Unknown Reserved Multicast Forward Rule (SGC.RMC_RULE) 1: Excludes CPU port
14:8	EN_FC	Apply 802.3x status after Auto-negotiation This field can individually control the 802.3x capability after Auto-negotiation is done. [Note] Port5 function is only valid when port 5 Giga MAC is implemented. 0: ignore the AN stats for 802.3x capability 1: follow the AN status for 802.3x capability
7	MAC_FCP_OPTION	Multicast Flow control/Backpressure option 0: When all ports are fc/bp disable, the switch will use drop_threshold to drop frames only. If not, the switch will use fc_threshold and drop_threshold. 1: When only the destination TX port is fc/bp disable, the switch will use drop_threshold to drop frames only. If not, that TX port uses fc_threshold and drop_threshold.
6:0	EN_BP	Apply back pressure capability [Note] Port5 function is only valid when port 5 Giga MAC is implemented. 0: ignore the back pressure mode (default OFF) 1: apply back pressure based on SGC.BP_MODE.

10110094 POC1

Port Control 1

0000000
0

Bit	31	30	29	28	27	26	25	24	23	22	21	20	19	18	17	16
-----	----	----	----	----	----	----	----	----	----	----	----	----	----	----	----	----

Name			DISIPMC2CPU							BLOCKING_STATE						
Type			RW							RW						
Reset			0	0	0	0	0	0	0	0	0	0	0	0	0	0
Bit	15	14	13	12	11	10	9	8	7	6	5	4	3	2	1	0
Name			DIS_LRNING							SA_SECURED_PORT						
Type			RW							RW						
Reset			0	0	0	0	0	0	0	0	0	0	0	0	0	0

Bit(s)	Name	Description
29:23	DISIPMC2CPU	Unknown IP Multicast Frame Excludes CPU 0: Unknown IP Multicast Forward Rule (SGC.IP_MULT_RULE) 1: Excludes CPU port
22:16	BLOCKING_STATE	Port State for Spanning Tree Protocol [Note]: Port5 function is only valid when port 5 Giga MAC is implemented. 0: normal state 1: blocking state, forwarding rmc packet to cpu(need programming address table)
14:8	DIS_LRNING	Disable SA learning [Note] Port5 function is only valid when port 5 Giga MAC is implemented. 0: default enabled 1: disable Source MAC learning
6:0	SA_SECURED_PORT	SA secured mode [Note*1]: Must set dis_learn and sa_secured at the same time. [Note*2] Port5 function is only valid when port 5 Giga MAC is implemented. 0: don't care SA match, 1: the packets' SA needs match, otherwise discard the packets

10110098 **POC2** **Port Control 2** 00007F0
0

Bit	31	30	29	28	27	26	25	24	23	22	21	20	19	18	17	16
Name		G1_TX_CHECK	G0_TX_CHECK				MLD2CPU_EN	IPV6_MULT_RULE		DIS_UC_PAUSE						
Type		RW	RW				RW	RW		RW						
Reset		0	0				0	0	0	0	0	0	0	0	0	0
Bit	15	14	13	12	11	10	9	8	7	6	5	4	3	2	1	0
Name	PE_VLAN_TAG_EN	ENAGING_PORT								UNTAG_EN						
Type	RW	RW								RW						
Reset	0	1	1	1	1	1	1	1		0	0	0	0	0	0	0

Bit(s)	Name	Description
30	G1_TX_CHECK	Check the port 6 TXC if no txc clock, then disable MII port 0: disable 1: enable, check TXC
29	G0_TX_CHECK	Check the port 5 TXC if no txc clock, then disable MII port [Note] This feature is only valid when port 5 Giga MAC is implemented. 0: disable 1: enable, check TXC
25	MLD2CPU_EN	MLD Message Packets forward to CPU 0: MLD message will be flooded

Bit(s)	Name	Description
24:23	IPV6_MULT_RULE	1: MLD message will be forward to CPU port only Unknown IPV6 Multicast Frame Forward Rule If no match in the address table, then folloing the rule 00: BC 01: to CPU 10: drop 11: Reserved
22:16	DIS_UC_PAUSE	Disable Unicast Pause Frame [Note] Port5 funciton is only valid when port 5 Giga MAC is implemented. 0: switch will consider pause frame when DA!=0180c20001 but unicast to CPU, 1: switch will not consider pause frame when DA!= 0180c20001 and unicast to CPU
15	PER_VLAN_UNTAG_EN	Per port per vlan untag enable VLAN tag removal option. 0: Use per port UNTAG_EN 1: Use untag enable bitmap in VLAN table
14:8	ENAGING_PORT	Port aging [Note] Port5 funciton is only valid when port 5 Giga MAC is implemented. 0: disable aging that the MAC address is belong to programmed port(s) 1: enable aging
6:0	UNTAG_EN	Per Port VLAN Tag Temoval [Note] Port5 funciton is only valid when port 5 Giga MAC is implemented. 0: disable 1: enable VLAN tag field removal.

1011009C **SGC**

Switch Global Control

6008A04
1

Bit	31	30	29	28	27	26	25	24	23	22	21	20	19	18	17	16
Name		BK OF F_A LG	LE N_ERR_C HK	IP_MULT_RULE		RMC_RUL E		LED_FLAS H_TIME		BISH_TH		BIS H_DIS	BP_MODE		DISMIPOR T_WASTX	
Type		RW	RW	RW		RW		RW		RW		RW	RW		RW	
Reset		1	1	0	0	0	0	0	0	0	0	0	1	0	0	0
Bit	15	14	13	12	11	10	9	8	7	6	5	4	3	2	1	0
Name	BP_JAM_CNT				DIS AB LE_TX_BA CK OF F	ADDRESS S_HASH_ALG		DIS_PK T_T X_A BO RT	PKT_MAX_LEN		BC_STOR M_PROT		AGING_INTERNAL			
Type	RW				RW	RW		RW	RW		RW		RW			
Reset	1	0	1	0	0	0	0	0	0	1	0	0	0	0	0	1

Bit(s)	Name	Description
30	BKOFF_ALG	Backoff Algorithm Option 0: default 1: comply with UNH test
29	LEN_ERR_CHK	Length of Received Frame Check Enable When the bit is set, the received packet length will be checked for length encapsulated frames. 0: default disabled 1: comply with UNH test
28:27	IP_MULT_RULE	Unknown IP Multicase Frame Forward Rule If no match in the address table, then following the rules. 00: BC 01: to cpu

Bit(s)	Name	Description
26:25	RMC_RULE	10: drop 11: reserved Unknown Reserved Multicast Frame Forward Rule If no match in the address table, then follow the rules. 00: to all port(not include blocking state port) 01: to cpu 10: drop 11: reserved
24:23	LED_FLASH_TIME	The Frequency Of LED Flash 00: 30ms 01: 60ms 10: 240ms 11: 480ms
22:21	BISH_TH	The Threshold Of Memory Bisshop 11: skip if fail 8 blocks, 0 00: skip if fail 16 (default, from pins) 01: skip if fail 48 10: skip if fail 64
20	BISH_DIS	Build In Self Hop 0: enable skip function 1: disable
19:18	BP_MODE	Back Pressure Mode 00: disable 01: BP jam, the jam number is set by bp_num 10: BP jamALL, jam packet until the BP condition is released(default), 11: BP carrier, use carrier insertion to do back pressure
17:16	DISMIIPORT_WAST X	GMI Port Disable Was_Transmit [Note] This feature is only valid when port 5 Giga MAC is implemented. 1: disable was_transmit (good for late CRS PHY, like HPNA2.0 or power-LAN), 0: enable
15:12	BP_JAM_CNT	Back Pressure Jam Number The consecutive jam count when back pressure is enabled, The default is 10 packet jam then one no-jam packet.
11	DISABLE_TX_BAC KOFF	Disable The Collision Back Off Timer 0: default 1: re-transmit immediately after collision
10:9	ADDRESSSS_HASH _ALG	MAC Address Hashing Algorithm 00: direct mode, using last 10-bit as hashing address 01: XOR48 mode 10: XOR32 mode 11: reserved
8	DIS_PKT_TX_ABO RT	Disable Packet TX Abort 1: Disable collision 16 packet abort and late collision abort 0: enable both abort
7:6	PKT_MAX_LEN	Maximum Packet Length Untaged / VLAN-taged 00: 1536 Bytes / 1536 Bytes 01: 1518 Bytes / 1522 Bytes 10: 1522 Bytes / 1526 Bytes 11: Reserved / Reserved
5:4	BC_STORM_PROT	Global Broadcast Storm Protection BC will be blocked, if the following number of BC blocks in in output queues 00: disable 01: 64 10: 96 11: 128
3:0	AGING_INTERNAL	Aging Timer 0000: disable age 0001: 300sec

Bit(s)	Name	Description
		0010 - 0111: 600 ~ 38400sec 1xxx: Fast Age (60sec)

101100A0 STRT Switch Reset 0000000
0

Bit	31	30	29	28	27	26	25	24	23	22	21	20	19	18	17	16
Name	RESET_SW[31:16]															
Type	WO															
Reset	0	0	0	0	0	0	0	0	0	0	0	0	0	0	0	0
Bit	15	14	13	12	11	10	9	8	7	6	5	4	3	2	1	0
Name	RESET_SW[15:0]															
Type	WO															
Reset	0	0	0	0	0	0	0	0	0	0	0	0	0	0	0	0

Bit(s)	Name	Description
31:0	RESET_SW	Reset switch engine, data, address, link memory , cpu port and ahb interface when writing data to the STRT register.

101100A4 LEDP0 LED Port0 0000000
5

Bit	31	30	29	28	27	26	25	24	23	22	21	20	19	18	17	16	
Name																	
Type																	
Reset																	
Bit	15	14	13	12	11	10	9	8	7	6	5	4	3	2	1	0	
Name														P0_LED			
Type														RW			
Reset														0	1	0	1

Bit(s)	Name	Description
3:0	P0_LED	port0 LED state, default = link/activity 0000: link 0001: 100M speed 0010: duplex 0011: activity 0100: collision 0101: link/activity 0110: duplex/collision 0111: 10M speed/activity 1000: 100M speed/activity 1011: off 1100: on 1010: blink

101100A8 LEDP1 LED Port1 0000000
5

Bit	31	30	29	28	27	26	25	24	23	22	21	20	19	18	17	16	
Name																	
Type																	
Reset																	
Bit	15	14	13	12	11	10	9	8	7	6	5	4	3	2	1	0	
Name														P1_LED			
Type														RW			
Reset														0	1	0	1

Bit(s)	Name	Description
--------	------	-------------

Reset									0	0	0	1	1	1	1	0
--------------	--	--	--	--	--	--	--	--	---	---	---	---	---	---	---	---

Bit(s)	Name	Description
7:0	BUF_STARV_TH	Buffer starvation threshold Switch will interrupt CPU when the global queue block counts is less than the threshold for 3 seconds.

101100BC DES Debug Signal 0000000

Bit	31	30	29	28	27	26	25	24	23	22	21	20	19	18	17	16
Name																
Type																
Reset																
Bit	15	14	13	12	11	10	9	8	7	6	5	4	3	2	1	0
Name	DEBUG_SIGNAL															
Type	RO															
Reset	0	0	0	0	0	0	0	0	0	0	0	0	0	0	0	0

Bit(s)	Name	Description
15:0	DEBUG_SIGNAL	Port 5 Debug Signal

101100C0 PCR0 PHY Control Register 0 0000000

Bit	31	30	29	28	27	26	25	24	23	22	21	20	19	18	17	16
Name	WT_NWAY_DATA															
Type	RW															
Reset	0	0	0	0	0	0	0	0	0	0	0	0	0	0	0	0
Bit	15	14	13	12	11	10	9	8	7	6	5	4	3	2	1	0
Name	RE SV0	RD _PH Y_C MD	WT _PH Y_C MD	CPU_PHY_REG									CPU_PHY_ADDR			
Type	RO	RW	RW	RW									RW			
Reset	0	0	0	0	0	0	0	0				0	0	0	0	0

Bit(s)	Name	Description
31:16	WT_NWAY_DATA	The Data Be Written into PHY
15	RESV0	Reserved
14	RD_PHY_CMD	Read command To enable read command on PHY, write 1 to this bit . After command is completed, this bit is self-cleared.
13	WT_PHY_CMD	Write command To enable write command on PHY, write 1 to this bit . After command is completed, this bit is self-cleared
12:8	CPU_PHY_REG	PHY register address
4:0	CPU_PHY_ADDR	PHY address (Note: The internal 5-ports PHY reserves the PHY address starting from 5'd0 ~ 5'd4. For the external PHY, the PHY address from 5'd5 to 5'd31 can be applied. The default PHY address of Port 5 is 5'd5 for auto-polling function.)

101100C4 PCR1 PHY Control Register 1 0000000

Bit	31	30	29	28	27	26	25	24	23	22	21	20	19	18	17	16
Name	RD_DATA															
Type	RO															

Reset	0	0	0	0	0	0	0	0	0	0	0	0	0	0	0	0
Bit	15	14	13	12	11	10	9	8	7	6	5	4	3	2	1	0
Name															RD_RDY	WT_DONE
Type															RC	RC
Reset															0	0

Bit(s)	Name	Description
31:16	RD_DATA	The Read Data
1	RD_RDY	Read Operation is Done
0	WT_DONE	Write Operation is Done

101100C8 FPA1

Force P5P6 Ability

0550032
8

Bit	31	30	29	28	27	26	25	24	23	22	21	20	19	18	17	16
Name			AP_EN	EXT_PHY_ADDR_BASE				G0_RXCLK_SKEW_SEL		G0_TXCLK_SKEW_SEL			TURBO_MII_CLK			
Type			RW	RW				RW		RW			RW			
Reset			0	0	0	1	0	1	0	1	0	1		0		
Bit	15	14	13	12	11	10	9	8	7	6	5	4	3	2	1	0
Name			FORCE_RGMII_LINK1	FORCE_RGMII_LINK0	FORCE_RGMII_EN1	FORCE_RGMII_EN0	FORCE_RGMII_XFC1		FORCE_RGMII_XFC0		FORCE_RGMII_DPX1	FORCE_RGMII_DPX0	FORCE_RGMII_SPD1		FORCE_RGMII_SPD0	
Type			RW	RW	RW	RW	RW		RW		RW	RW	RW		RW	
Reset			0	0	0	0	1	1	0	0	1	0	1	0	0	0

Bit(s)	Name	Description
29	AP_EN	Port 5 Auto Polling Enable [Note] This feature is only valid when port 5 Giga MAC is implemented.
28:24	EXT_PHY_ADDR_BASE	Port 5 External PHY Base Address [Note] This feature is only valid when port 5 Giga MAC is implemented.
23:22	G0_RXCLK_SKEW_SEL	Port 5 RXCLK Skew Selection [Note] This feature is only valid when port 5 Giga MAC is implemented.
21:20	G0_TXCLK_SKEW_SEL	Port 5 TXCLK Skew Selection [Note] This feature is only valid when port 5 Giga MAC is implemented.
18	TURBO_MII_CLK	Port 5 revMII Mode Clock Selection [Note] This feature is only valid when port 5 Giga MAC is implemented. 0: 25MHz output clock 1: 31.25MHz output clock
13	FORCE_RGMII_LINK1	Force Port 6 Link This field is valid only FORCE_MDOE is set. The final resolution is reported to POA register. 0: link down 1: link up
12	FORCE_RGMII_LINK0	Force Port 5 Link This field is valid only FORCE_MDOE is set. The final resolution is reported to POA register. [Note] This feature is only valid when port 5 Giga MAC is implemented. 0: link down 1: link up
11	FORCE_RGMII_EN	Force Port 6 Enable

Bit(s)	Name	Description
1		0: reserved 1: force mode. Auto-negotiation status is ignored. Port 5 ability is forced according to the following fields of the register FPA1.
10	FORCE_RGMII_EN 0	Force Port 5 Enable [Note] This feature is only valid when port 5 Giga MAC is implemented. 0: default 1: force mode. Auto-negotiation status is ignored. Port 5 ability is forced according to the following fields of the register FPA1.
9:8	FORCE_RGMII_XF C1	Force port 6 flow control ability This field is valid only FORCE_MDOE is set. The final resolution is reported to POA register. 1x: for tx x1: for rx
7:6	FORCE_RGMII_XF C0	Force port 5 flow control ability This field is valid only FORCE_MDOE is set. The final resolution is reported to POA register. [Note] This feature is only valid when port 5 Giga MAC is implemented. 1x: for tx x1: for rx
5	FORCE_RGMII_DP X1	Force port 6 duplex This field is valid only FORCE_MDOE is set. The final resolution is reported to POA register. 0: half duplex 1: full duplex
4	FORCE_RGMII_DP X0	Force port 5 duplex This field is valid only FORCE_MDOE is set. The final resolution is reported to POA register. [Note] This feature is only valid when port 5 Giga MAC is implemented. 0: half duplex 1: full duplex
3:2	FORCE_RGMII_SP D1	Force port 6 speed This field is valid only FORCE_MDOE is set. The final resolution is reported to POA register. 1x: 1GbpsMhz 01: 100MbpsMHz 00: 10MbpsMHz
1:0	FORCE_RGMII_SP D0	Force port 5 speed This field is valid only FORCE_MDOE is set. The final resolution is reported to POA register. [Note] This feature is only valid when port 5 Giga MAC is implemented. 1x: 1GbpsMhz 01: 100MbpsMHz 00: 10MbpsMHz

101100CC FCT2

Flow Control Threshold 2

0000A30
C

Bit	31	30	29	28	27	26	25	24	23	22	21	20	19	18	17	16
Name								DIS_IPV6MC2CPU								MUST_DR OP_RLS_T H[4:3]
Type								RW								RW
Reset								0	0	0	0	0	0	0	0	0
Bit	15	14	13	12	11	10	9	8	7	6	5	4	3	2	1	0
Name	MUST_DROP_RL S_TH[2:0]			MUST_DROP_SET_TH						MC_PER_PORT_TH						
Type	RW			RW						RW						
Reset	1	0	1	0	0	0	1	1			0	0	1	1	0	0

Bit(s)	Name	Description
24:18	DIS_IPV6MC2CPU	Unknown IPv6 Multicast Frame Excludes CPU

Bit(s)	Name	Description
		0: Unknown IPv6 Multicast Forward Rule (POC2.IPV6_MULT_RULE) 1: Exclude CPU port
17:13	MUST_DROP_RLS_TH	If the global queue pointer higher than the threshold. The must drop condition will be released.
12:8	MUST_DROP_SET_TH	If the global queue pointer reach msut drop threshold. All incoming packets have to be dropped.
5:0	MC_PER_PORT_TH	MC packets per port threshold. When the global queue reaches the flow control threshold on register FCT0, per port output threshold for MC packet will be checked to enable flow-control or packet-drop on incoming MC packets.

101100D0 QSS0 Queue Status 0 0000000
0

Bit	31	30	29	28	27	26	25	24	23	22	21	20	19	18	17	16
Name									BE_CNT_R[8:1]							
Type									RO							
Reset									0	0	0	0	0	0	0	0
Bit	15	14	13	12	11	10	9	8	7	6	5	4	3	2	1	0
Name	BE_CNT_R [0:0]	BK_CNT_R										SEE_CNT_PORT_SEL				
Type	RO	RO										RW				
Reset	0	0	0	0	0	0	0	0	0	0	0	0	0	0	0	0

Bit(s)	Name	Description
23:15	BE_CNT_R	Link control best effort queue block counter monitor.
14:5	BK_CNT_R	Link control background queue block counter monitor.
4:0	SEE_CNT_PORT_SEL	Link control bock couonter port selection

101100D4 QSS1 Queue Status 1 0000000
0

Bit	31	30	29	28	27	26	25	24	23	22	21	20	19	18	17	16
Name															VO_CNT_R[8:7]	
Type															RO	
Reset															0	0
Bit	15	14	13	12	11	10	9	8	7	6	5	4	3	2	1	0
Name	VO_CNT_R[6:0]							CL_CNT_R								
Type	RO							RO								
Reset	0	0	0	0	0	0	0	0	0	0	0	0	0	0	0	0

Bit(s)	Name	Description
17:9	VO_CNT_R	Link control voice queue block counter monitor.
8:0	CL_CNT_R	Link control control queue block counter monitor.

101100D8 DEC Debug Control 4040010
0

Bit	31	30	29	28	27	26	25	24	23	22	21	20	19	18	17	16
Name	SW2FE_IPG								FE2SW_IPG							
Type	RW								RW							
Reset	0	1	0	0	0	0	0	0	0	1	0	0	0	0	0	0
Bit	15	14	13	12	11	10	9	8	7	6	5	4	3	2	1	0

Name										BRI DG E_E N							
Type										RW							
Reset										1							

Bit(s)	Name	Description
31:24	SW2FE_IPG	SW2FE Bridge IPG Byte Count Inter-Frame Byte Count between the consecutive frames flowing from Switch to Frame Engine
23:16	FE2SW_IPG	FE2SW Bridge IPG byte count Inter-Frame Byte Count between the consecurtive frames flowing from Frame Engine to Switch
8	BRIDGE_EN	Enable FE2SW Bridge IPG Prevention 1'b0: Disable 1'b1: Enable IPG Prevention when FE2SW_BRIDGE_IPG is too short (8'd16) to receive the next frame.

101100DC MTI Memory Test Information 0000006
A

Bit	31	30	29	28	27	26	25	24	23	22	21	20	19	18	17	16
Name																
Type																
Reset																
Bit	15	14	13	12	11	10	9	8	7	6	5	4	3	2	1	0
Name										SW _R AM _T E S T _D O N E	LK _R AM _T E S T _D O N E	LK _R AM _T E S T _F A I L	AT _R AM _T E S T _D O N E	AT _R AM _T E S T _F A I L	DT _R AM _T E S T _D O N E	DT _R AM _T E S T _F A I L
Type										RO	RO	RO	RO	RO	RO	RO
Reset										1	1	0	1	0	1	0

Bit(s)	Name	Description
6	SW_RAM_TEST_D ONE	Switch Memory Ram Test Done
5	LK_RAM_TEST_D ONE	Link Ram Test Done
4	LK_RAM_TEST_FAI L	Link Ram Test Fail
3	AT_RAM_TEST_D ONE	Address Table Ram Test Done
2	AT_RAM_TEST_FAI L	Address Table Ram Test Fail
1	DT_RAM_TEST_D ONE	Data Buffer Ram Test Done
0	DT_RAM_TEST_FA IL	Data Buffer Ram Test Fail

101100E0 PPC Packet Counter 0000000
0

Bit	31	30	29	28	27	26	25	24	23	22	21	20	19	18	17	16
Name	SW2FE_CNT															
Type	RO															
Reset	0	0	0	0	0	0	0	0	0	0	0	0	0	0	0	0

Bit	15	14	13	12	11	10	9	8	7	6	5	4	3	2	1	0
Name	FE2SW_CNT															
Type	RO															
Reset	0	0	0	0	0	0	0	0	0	0	0	0	0	0	0	0

Bit(s)	Name	Description
31:16	SW2FE_CNT	SW2FE_CNT Switch to frame engine packet counter
15:0	FE2SW_CNT	FE2SW_CNT Frame engine to switch packet counter

101100E4 SGC2 Switch Global Control 2 0000000

Bit	31	30	29	28	27	26	25	24	23	22	21	20	19	18	17	16
Name	P6_RX_FC_QUE_EN	P6_TXFC_WL_EN	LAN_PMAP						SPECIAL_TAG_EN	TX_CPU_TPID_BIT_MAP						
Type	RW	RW	RW						RW	RW						
Reset	0	0	0	0	0	0	0	0	0	0	0	0	0	0	0	0
Bit	15	14	13	12	11	10	9	8	7	6	5	4	3	2	1	0
Name				P6_TXFC_QUE_EN	AR_BIT_EN	CPU_TPID_EN	AR_BIT_EN	SLOT_4TO1		DOUBLE_TAG_EN						
Type				RW	RW	RW	RW	RW		RW						
Reset				0	0	0	0	0		0	0	0	0	0	0	0

Bit(s)	Name	Description
31	P6_RXFC_QUE_EN	Port 6 RX flow control on per egress queue 0: Port 6 RX flow control will pause all 4 egress queue 1: Port 6 RX flow control will pause 4 egress queue independently according to the corresponding congestion signals.
30	P6_TXFC_WL_EN	Port 6 TX flow controll by Switch WAN/LAN port 0: Port 6 TX flow control is decided by any port and any queue of the Switch congestion 1: Port 6 TX flow control is decided by WAN/LAN port of the Switch congestion separately.
29:24	LAN_PMAP	Lan port bit map This field indicates per port attribute used for flow control. (Note: Port5 funciton is only valid when port 5 Giga MAC is implemented) 1: Lan port 0: Wan port
23	SPECIAL_TAG_EN	Special Tag enable 0: default; RX special tag is enabled according to the global control bit-CPU_TPID_EN. TX special tag is enabled according to the per-port TX_CPU_TPID_BIT_MAP 1: CPU_TPID_EN is not used Both TX and RX special tag feature are decided by the per-port TX_CPU_TPID_BIT_MAP
22:16	TX_CPU_TPID_BIT_MAP	Transmit CPU TPID(810x) port bit map 0: default (TPID=0x8100) 1: TPID=0x810? depending on TX/RX usages (Note: Port5 funciton is only valid when port 5 Giga MAC is implemented)
12	P6_TXFC_QUE_EN	Port 6 per queue TX flow control This bit is only valid when P6_TXFC_WL_EN is enabled. 0: 4 congest signals to Frame Engine are decided by the wired-or result of all egress queues on Switch WAN/LAN ports. 1: 4 congest signals to Frame Engine are decided by the individual and the corresponding 4 egress queues on Switch WAN/LAN ports.

Bit(s)	Name	Description
11	ARBITER_LAN_EN	Memory arbiter only for P0~P4 enable 0: default 1: memory arbiter only for P0~P4.
10	CPU_TPID_EN	CPU TPID(81xx) enable 0: disable. CPU TPID=8100 1: enable. CPU TPID=810x.
9	ARBITER_GPT_EN	Memory Arbiter only for P5 and P6 0: default 1: Enable
8	SLOT_4TO1	Memory Arbiter Ratio Selection 0: (P5,P6) : (P0-P4) = 3:2 1: (P5,P6) : (P0-P4) = 4:1
6:0	DOUBLE_TAG_EN	Insert double tag field When this bit is set , the incoming packet is allowed to insert outer or double tag. 1: enable double tag field 0: disable the double tag field. (Note: Port5 funciton is only valid when port 5 Giga MAC is implemented)

101100E8 P0PC Port 0 Packet Counter 0000000 0

Bit	31	30	29	28	27	26	25	24	23	22	21	20	19	18	17	16
Name	BAD_PKT_CNT0															
Type	RO															
Reset	0	0	0	0	0	0	0	0	0	0	0	0	0	0	0	0
Bit	15	14	13	12	11	10	9	8	7	6	5	4	3	2	1	0
Name	GOOD_PKT_CNT0															
Type	RO															
Reset	0	0	0	0	0	0	0	0	0	0	0	0	0	0	0	0

Bit(s)	Name	Description
31:16	BAD_PKT_CNT0	Port 0 Receive Bad Packet Counter
15:0	GOOD_PKT_CNT0	Port 0 Receive Good Packet Counter

101100EC P1PC Port 1 Packet Counter 0000000 0

Bit	31	30	29	28	27	26	25	24	23	22	21	20	19	18	17	16
Name	BAD_PKT_CNT1															
Type	RO															
Reset	0	0	0	0	0	0	0	0	0	0	0	0	0	0	0	0
Bit	15	14	13	12	11	10	9	8	7	6	5	4	3	2	1	0
Name	GOOD_PKT_CNT1															
Type	RO															
Reset	0	0	0	0	0	0	0	0	0	0	0	0	0	0	0	0

Bit(s)	Name	Description
31:16	BAD_PKT_CNT1	Port 1 Receive Bad Packet Counter
15:0	GOOD_PKT_CNT1	Port 1 Receive Good Packet Counter

101100F0 P2PC Port 2 Packet Counter 0000000 0

Bit	31	30	29	28	27	26	25	24	23	22	21	20	19	18	17	16
Name	BAD_PKT_CNT2															

Type	RO															
Reset	0	0	0	0	0	0	0	0	0	0	0	0	0	0	0	0
Bit	15	14	13	12	11	10	9	8	7	6	5	4	3	2	1	0
Name	GOOD_PKT_CNT2															
Type	RO															
Reset	0	0	0	0	0	0	0	0	0	0	0	0	0	0	0	0

Bit(s)	Name	Description
31:16	BAD_PKT_CNT2	Port 2 Receive Bad Packet Counter
15:0	GOOD_PKT_CNT2	Port 2 Receive Good Packet Counter

101100F4 P3PC Port 3 Packet Counter 0000000
0

Bit	31	30	29	28	27	26	25	24	23	22	21	20	19	18	17	16
Name	BAD_PKT_CNT3															
Type	RO															
Reset	0	0	0	0	0	0	0	0	0	0	0	0	0	0	0	0
Bit	15	14	13	12	11	10	9	8	7	6	5	4	3	2	1	0
Name	GOOD_PKT_CNT3															
Type	RO															
Reset	0	0	0	0	0	0	0	0	0	0	0	0	0	0	0	0

Bit(s)	Name	Description
31:16	BAD_PKT_CNT3	Port 3 Receive Bad Packet Counter
15:0	GOOD_PKT_CNT3	Port 3 Receive Good Packet Counter

101100F8 P4PC Port 4 Packet Counter 0000000
0

Bit	31	30	29	28	27	26	25	24	23	22	21	20	19	18	17	16
Name	BAD_PKT_CNT4															
Type	RO															
Reset	0	0	0	0	0	0	0	0	0	0	0	0	0	0	0	0
Bit	15	14	13	12	11	10	9	8	7	6	5	4	3	2	1	0
Name	GOOD_PKT_CNT4															
Type	RO															
Reset	0	0	0	0	0	0	0	0	0	0	0	0	0	0	0	0

Bit(s)	Name	Description
31:16	BAD_PKT_CNT4	Port 4 Receive Bad Packet Counter
15:0	GOOD_PKT_CNT4	Port 4 Receive Good Packet Counter

101100FC P5PC Port 5 Packet Counter 0000000
0

Bit	31	30	29	28	27	26	25	24	23	22	21	20	19	18	17	16
Name	BAD_PKT_CNT5															
Type	RO															
Reset	0	0	0	0	0	0	0	0	0	0	0	0	0	0	0	0
Bit	15	14	13	12	11	10	9	8	7	6	5	4	3	2	1	0
Name	GOOD_PKT_CNT5															
Type	RO															
Reset	0	0	0	0	0	0	0	0	0	0	0	0	0	0	0	0

Bit(s)	Name	Description
31:16	BAD_PKT_CNT5	Port 5 Receive Bad Packet Counter
15:0	GOOD_PKT_CNT5	Port 5 Receive Good Packet Counter

10110100 VUB0 VLAN Untag Block 0 0000000
0

Bit	31	30	29	28	27	26	25	24	23	22	21	20	19	18	17	16
Name					VLAN_3_UNTAG_EN						VLAN_2_UNTAG_EN[6:2]					
Type					RW						RW					
Reset					0	0	0	0	0	0	0	0	0	0	0	0
Bit	15	14	13	12	11	10	9	8	7	6	5	4	3	2	1	0
Name	VLAN_2_UNTAG_EN[1:0]		VLAN_1_UNTAG_EN						VLAN_0_UNTAG_EN							
Type	RW		RW						RW							
Reset	0	0	0	0	0	0	0	0	0	0	0	0	0	0	0	0

Bit(s)	Name	Description
27:21	VLAN_3_UNTAG_EN	Port 0 ~ 6 untag_en of VLAN 3
20:14	VLAN_2_UNTAG_EN	Port 0 ~ 6 untag_en of VLAN 2
13:7	VLAN_1_UNTAG_EN	Port 0 ~ 6 untag_en of VLAN 1
6:0	VLAN_0_UNTAG_EN	Port 0 ~ 6 untag_en of VLAN 0

10110104 VUB1 VLAN Untag Block 1 0000000
0

Bit	31	30	29	28	27	26	25	24	23	22	21	20	19	18	17	16
Name					VLAN_7_UNTAG_EN						VLAN_6_UNTAG_EN[6:2]					
Type					RW						RW					
Reset					0	0	0	0	0	0	0	0	0	0	0	0
Bit	15	14	13	12	11	10	9	8	7	6	5	4	3	2	1	0
Name	VLAN_6_UNTAG_EN[1:0]		VLAN_5_UNTAG_EN						VLAN_4_UNTAG_EN							
Type	RW		RW						RW							
Reset	0	0	0	0	0	0	0	0	0	0	0	0	0	0	0	0

Bit(s)	Name	Description
27:21	VLAN_7_UNTAG_EN	Port 0 ~ 6 untag_en of VLAN 7
20:14	VLAN_6_UNTAG_EN	Port 0 ~ 6 untag_en of VLAN 6
13:7	VLAN_5_UNTAG_EN	Port 0 ~ 6 untag_en of VLAN 5
6:0	VLAN_4_UNTAG_EN	Port 0 ~ 6 untag_en of VLAN 4

10110108 VUB2 VLAN Untag Block 2 0000000
0

Bit	31	30	29	28	27	26	25	24	23	22	21	20	19	18	17	16
Name					VLAN_11_UNTAG_EN						VLAN_10_UNTAG_EN[6:2]					
Type					RW						RW					
Reset					0	0	0	0	0	0	0	0	0	0	0	0
Bit	15	14	13	12	11	10	9	8	7	6	5	4	3	2	1	0
Name	VLAN_10_UNTAG_EN[1:0]		VLAN_9_UNTAG_EN						VLAN_8_UNTAG_EN							

Type	RW		RW							RW							
Reset	0	0	0	0	0	0	0	0	0	0	0	0	0	0	0	0	0

Bit(s)	Name	Description
27:21	VLAN_11_UNTAG_EN	Port 0 ~ 6 untag_en of VLAN 11
20:14	VLAN_10_UNTAG_EN	Port 0 ~ 6 untag_en of VLAN 10
13:7	VLAN_9_UNTAG_EN	Port 0 ~ 6 untag_en of VLAN 9
6:0	VLAN_8_UNTAG_EN	Port 0 ~ 6 untag_en of VLAN 8

1011010C VUB3 **VLAN Untag Block 3** **0000000**
0

Bit	31	30	29	28	27	26	25	24	23	22	21	20	19	18	17	16
Name					VLAN_15_UNTAG_EN						VLAN_14_UNTAG_EN[6:2]					
Type					RW						RW					
Reset					0	0	0	0	0	0	0	0	0	0	0	0
Bit	15	14	13	12	11	10	9	8	7	6	5	4	3	2	1	0
Name	VLAN_14_UNTAG_EN[1:0]		VLAN_13_UNTAG_EN						VLAN_12_UNTAG_EN							
Type	RW		RW						RW							
Reset	0	0	0	0	0	0	0	0	0	0	0	0	0	0	0	0

Bit(s)	Name	Description
27:21	VLAN_15_UNTAG_EN	Port 0 ~ 6 untag_en of VLAN 15
20:14	VLAN_14_UNTAG_EN	Port 0 ~ 6 untag_en of VLAN 14
13:7	VLAN_13_UNTAG_EN	Port 0 ~ 6 untag_en of VLAN 13
6:0	VLAN_12_UNTAG_EN	Port 0 ~ 6 untag_en of VLAN 12

10110110 BMU_CTRL **BC/MC/UN Rate Limit Control** **7C00000**
0

Bit	31	30	29	28	27	26	25	24	23	22	21	20	19	18	17	16		
Name		ONE_US_CYCLE_NUM									P5_RATE_LIMIT_CTRL				P4_RATE_LIMIT_CTRL			
Type		RW									RW				RW			
Reset		1	1	1	1	1	0	0		0	0	0		0	0	0		
Bit	15	14	13	12	11	10	9	8	7	6	5	4	3	2	1	0		
Name		P3_RATE_LIMIT_CTRL					P2_RATE_LIMIT_CTRL					P1_RATE_LIMIT_CTRL				P0_RATE_LIMIT_CTRL		
Type		RW					RW					RW				RW		
Reset		0	0	0		0	0	0		0	0	0		0	0	0		

Bit(s)	Name	Description
30:24	ONE_US_CYCLE_NUM	One micro-second Cycle Number This field is used to calculate 1us period
22:20	P5_RATE_LIMIT_CTRL	Port 5 rate Limit Control (Note: This feature is only alid when port 5 GMAC is implemented)
18:16	P4_RATE_LIMIT_CTRL	Port 4 rate Limit Control
14:12	P3_RATE_LIMIT_CTRL	Port 3 rate Limit Control

Bit(s)	Name	Description
	TRL	
10:8	P2_RATE_LIMIT_C TRL	Port 2 rate Limit Control
6:4	P1_RATE_LIMIT_C TRL	Port 1 rate Limit Control
2:0	P0_RATE_LIMIT_C TRL	Port 0 rate Limit Control 2: Broadcast frame enable 1: Multicast frame enable 0: Unknown frame enable

10110114 BMU_LMT_N **BC/MC/UN Rate Limit Frame Number** FFFFFFFF
UM1 FF

Bit	31	30	29	28	27	26	25	24	23	22	21	20	19	18	17	16
Name	RATE_LIMIT_NUM_100M															
Type	RW															
Reset	1	1	1	1	1	1	1	1	1	1	1	1	1	1	1	1
Bit	15	14	13	12	11	10	9	8	7	6	5	4	3	2	1	0
Name	RATE_LIMIT_NUM_10M															
Type	RW															
Reset	1	1	1	1	1	1	1	1	1	1	1	1	1	1	1	1

Bit(s)	Name	Description
31:16	RATE_LIMIT_NUM_100M	Rate Limit Received BC/MC/UN frame number in 100M in 100ms duration
15:0	RATE_LIMIT_NUM_10M	Rate Limit Received BC/MC/UN frame number in 10M in 1s duration

10110118 BMU_LMT_N **BC/MC/UN Rate Limit Frame Number** 1818FFFF
UM2 F

Bit	31	30	29	28	27	26	25	24	23	22	21	20	19	18	17	16
Name	IG_RATE_BYTE_OPT	IG_RATE_BYTE_NUM							EG_RATE_BYTE_OPT	EG_RATE_BYTE_NUM						
Type	RW	RW							RW	RW						
Reset	0	0	0	1	1	0	0	0	0	0	0	1	1	0	0	0
Bit	15	14	13	12	11	10	9	8	7	6	5	4	3	2	1	0
Name	RATE_LIMIT_NUM_1000M															
Type	RW															
Reset	1	1	1	1	1	1	1	1	1	1	1	1	1	1	1	1

Bit(s)	Name	Description
31	IG_RATE_BYTE_OPT	Ingress Rate Byte Option 0: Add 1: Minus
30:24	IG_RATE_BYTE_NUM	Ingress Rate Byte Number
23	EG_RATE_BYTE_OPT	Egress Rate Byte Option 0: Add 1: Minus
22:16	EG_RATE_BYTE_NUM	Egress Rate Byte Number
15:0	RATE_LIMIT_NUM_1000M	Rate Limit Received BC/MC/UN frame number in 1000M in 10ms

Bit(s)	Name	Description
1000M		duration (note: This feature is only valid whe port 5 GMAC is implemented)

1011011C P01_ING_CTR Port 0&1 Ingress Rate Limit Control 0000000
L 0

Bit	31	30	29	28	27	26	25	24	23	22	21	20	19	18	17	16
Name		P1_INGRESS_CTRL	P1_MNG_PKT_BYPASS	P1_INGRESS_FLOW_CTRL_ON	P1_TIMER_TICK		P1_TOKEN									
Type		RW	RW	RW	RW		RW									
Reset		0	0	0	0	0	0	0	0	0	0	0	0	0	0	0
Bit	15	14	13	12	11	10	9	8	7	6	5	4	3	2	1	0
Name		P0_INGRESS_CTRL	P0_MNG_PKT_BYPASS	P0_INGRESS_FLOW_CTRL_ON	P0_TIMER_TICK		P0_TOKEN									
Type		RW	RW	RW	RW		RW									
Reset		0	0	0	0	0	0	0	0	0	0	0	0	0	0	0

Bit(s)	Name	Description
30	P1_INGRESS_CTRL L	Port1 Ingress Limit Control 0: OFF 1: ON
29	P1_MNG_PKT_BYPASS	Port1 Management Packet ByPass 0: All packet included 1: Mangement Frame Excluded
28	P1_INGRESS_FLOW_CTRL_ON	Port 1 Ingress rate Flow Control When the bit is set, the pause frame is used prior to packet dropped according to P1_ING_THRES. If the bucket is empty, then P1 will start to discard the received packets except those specific packet in P1_MNG_PKY_BYPASS mode. 0: OFF 1: ON
27:26	P1_TIMER_TICK	Port 1 Timer Tick 0: 512us 1: 128us 2: 32us 3: 8us
25:16	P1_TOKEN	Port 1 Token Every timer tick, Token number bytes will be added into the bucket. (Unit : Byte) The maximum space of this bucket is 16'hFFFF bytes
14	P0_INGRESS_CTRL L	Port 0 Ingress Limit Control 0: OFF 1: ON
13	P0_MNG_PKT_BYPASS	Port 0 Management Packet ByPass 0: All packet included 1: Mangement Frame Excluded
12	P0_INGRESS_FLOW_CTRL_ON	Port 0 Ingress rate Flow Control When the bit is set, the pause frame is used prior to packet dropped

Bit(s)	Name	Description
		according to P0_ING_THRES. If the bucket is empty, then P0 will start to discard the received packets except those specific packet in P0_MNG_PKY_BYPASS mode. 0: OFF 1: ON
11:10	P0_TIMER_TICK	Port 0 Timer Tick 0: 512us 1: 128us 2: 32us 3: 8us
9:0	P0_TOKEN	Port 0 Token Every timer tick, Token number bytes will be added into the bucket. (Unit : Byte) The maximum space of this bucket is 16'hFFFF bytes

10110120 P23_ING_CTR Port 2&3 Ingress Rate Limit Control 0000000
L 0

Bit	31	30	29	28	27	26	25	24	23	22	21	20	19	18	17	16
Name		P3_INGRESS_CTRL	P3_MNG_PKT_BYPASS	P3_INGRESS_FLOW_CTRL_ON	P3_TIMER_TICK		P3_TOKEN									
Type		RW	RW	RW	RW		RW									
Reset		0	0	0	0	0	0	0	0	0	0	0	0	0	0	0
Bit	15	14	13	12	11	10	9	8	7	6	5	4	3	2	1	0
Name		P2_INGRESS_CTRL	P2_MNG_PKT_BYPASS	P2_INGRESS_FLOW_CTRL_ON	P2_TIMER_TICK		P2_TOKEN									
Type		RW	RW	RW	RW		RW									
Reset		0	0	0	0	0	0	0	0	0	0	0	0	0	0	0

Bit(s)	Name	Description
30	P3_INGRESS_CTRL	Port 3 Ingress Limit Control 0: OFF 1: ON
29	P3_MNG_PKT_BYPASS	Port 3 Management Packet ByPass 0: All packet included 1: Mangement Frame Excluded
28	P3_INGRESS_FLOW_CTRL_ON	Port 3 Ingress rate Flow Control When the bit is set, the pause frame is used prior to packet dropped according to P3_ING_THRES. If the bucket is empty, then P3 will start to discard the received packets except those specific packet in P3_MNG_PKY_BYPASS mode. 0: OFF 1: ON
27:26	P3_TIMER_TICK	Port 3 Timer Tick 0: 512us 1: 128us 2: 32us 3: 8us
25:16	P3_TOKEN	Port 3 Token

Bit(s)	Name	Description
		Every timer tick, Token number bytes will be added into the bucket. (Unit : Byte) The maximum space of this bucket is 16'hFFFF bytes
14	P2_INGRESS_CTRL	Port 2 Ingress Limit Control 0: OFF 1: ON
13	P2_MNG_PKT_BYPASS	Port 2 Management Packet ByPass 0: All packet included 1: Mangement Frame Excluded
12	P2_INGRESS_FLOW_CTRL_ON	Port 2 Ingress rate Flow Control When the bit is set, the pause frame is used prior to packet dropped according to P2_ING_THRES. If the bucket is empty, then P2 will start to discard the received packets except those specific packet in P2_MNG_PKY_BYPASS mode. 0: OFF 1: ON
11:10	P2_TIMER_TICK	Port 2 Timer Tick 0: 512us 1: 128us 2: 32us 3: 8us
9:0	P2_TOKEN	Port 2 Token Every timer tick, Token number bytes will be added into the bucket. (Unit : Byte) The maximum space of this bucket is 16'hFFFF bytes

10110124 **P45 ING CTRL** Port 4&5 Ingress Rate Limit Control 0000000
L 0

Bit	31	30	29	28	27	26	25	24	23	22	21	20	19	18	17	16
Name		P5_INGRESS_CTRL	P5_MNG_PKT_BYPASS	P5_INGRESS_FLOW_CTRL_ON	P5_TIMER_TICK		P5_TOKEN									
Type		RW	RW	RW	RW		RW									
Reset		0	0	0	0	0	0	0	0	0	0	0	0	0	0	0
Bit	15	14	13	12	11	10	9	8	7	6	5	4	3	2	1	0
Name		P4_INGRESS_CTRL	P4_MNG_PKT_BYPASS	P4_INGRESS_FLOW_CTRL_ON	P4_TIMER_TICK		P4_TOKEN									
Type		RW	RW	RW	RW		RW									
Reset		0	0	0	0	0	0	0	0	0	0	0	0	0	0	0

Bit(s)	Name	Description
30	P5_INGRESS_CTRL	Port 5 Ingress Limit Control 0: OFF 1: ON
29	P5_MNG_PKT_BYPASS	Port 5 Management Packet ByPass 0: All packet included 1: Mangement Frame Excluded
28	P5_INGRESS_FLOW	Port 5 Ingress rate Flow Control

Bit(s)	Name	Description
	W_CTRL_ON	When the bit is set, the pause frame is used prior to packet dropped according to P5_ING_THRES. If the bucket is empty, then P5 will start to discard the received packets except those specific packet in P5_MNG_PKY_BYPASS mode. 0: OFF 1: ON
27:26	P5_TIMER_TICK	Port 5 Timer Tick 0: 512us 1: 128us 2: 32us 3: 8us
25:16	P5_TOKEN	Port 5 Token Every timer tick, Token number bytes will be added into the bucket. (Unit : Byte) The maximum space of this bucket is 16'hFFFF bytes
14	P4_INGRESS_CTRL	Port 4 Ingress Limit Control 0: OFF 1: ON
13	P4_MNG_PKT_BYPASS	Port 4 Management Packet ByPass 0: All packet included 1: Mangement Frame Excluded
12	P4_INGRESS_FLOW_CTRL_ON	Port 4 Ingress rate Flow Control When the bit is set, the pause frame is used prior to packet dropped according to P4_ING_THRES. If the bucket is empty, then P4 will start to discard the received packets except those specific packet in P4_MNG_PKY_BYPASS mode. 0: OFF 1: ON
11:10	P4_TIMER_TICK	Port 4 Timer Tick 0: 512us 1: 128us 2: 32us 3: 8us
9:0	P4_TOKEN	Port 4 Token Every timer tick, Token number bytes will be added into the bucket. (Unit : Byte) The maximum space of this bucket is 16'hFFFF bytes

10110128 P0_ING_THRES Port 0 Ingress Rate Limit Threshold AAAA55
S 55

Bit	31	30	29	28	27	26	25	24	23	22	21	20	19	18	17	16
Name	P0_IN_FCOFF_THRES															
Type	RW															
Reset	1	0	1	0	1	0	1	0	1	0	1	0	1	0	1	0
Bit	15	14	13	12	11	10	9	8	7	6	5	4	3	2	1	0
Name	P0_IN_FCON_THRES															
Type	RW															
Reset	0	1	0	1	0	1	0	1	0	1	0	1	0	1	0	1

Bit(s)	Name	Description
31:16	P0_IN_FCOFF_THRES	Port 0 ingress rate limit flow control off. If P0_INGRESS_FLOW_CTRL_ON = 1 and P0 Flow control capability is on (XFC status in 0x80), then P0 will initiate PAUSE OFF frame or stop backpressure.
15:0	P0_IN_FCON_THRES	Port 0 ingress rate limit flow control on. If P0_INGRESS_FLOW_CTRL_ON = 1 and P0 Flow control capability is on (XFC status in 0x80), then P0 will initiate PAUSE ON frame or backpressure.

1011012C P1_ING_THRE Port 1 Ingress Rate Limit Threshold AAAA55
S 55

Bit	31	30	29	28	27	26	25	24	23	22	21	20	19	18	17	16
Name	P1_IN_FCOFF_THRES															
Type	RW															
Reset	1	0	1	0	1	0	1	0	1	0	1	0	1	0	1	0
Bit	15	14	13	12	11	10	9	8	7	6	5	4	3	2	1	0
Name	P1_IN_FCON_THRES															
Type	RW															
Reset	0	1	0	1	0	1	0	1	0	1	0	1	0	1	0	1

Bit(s)	Name	Description
31:16	P1_IN_FCOFF_THR ES	Port 1 ingress rate limit flow control off. If P1_INGRESS_FLOW_CTRL_ON = 1 and P1 Flow control capability is on (XFC status in 0x80), then P2 will initiate PAUSE OFF frame or stop backpressure.
15:0	P1_IN_FCON_THR ES	Port 1 ingress rate limit flow control on. If P1_INGRESS_FLOW_CTRL_ON = 1 and P1 Flow control capability is on (XFC status in 0x80), then P1 will initiate PAUSE ON frame or backpressure.

10110130 P2_ING_THRE Port 2 Ingress Rate Limit Threshold AAAA55
S 55

Bit	31	30	29	28	27	26	25	24	23	22	21	20	19	18	17	16
Name	P2_IN_FCOFF_THRES															
Type	RW															
Reset	1	0	1	0	1	0	1	0	1	0	1	0	1	0	1	0
Bit	15	14	13	12	11	10	9	8	7	6	5	4	3	2	1	0
Name	P2_IN_FCON_THRES															
Type	RW															
Reset	0	1	0	1	0	1	0	1	0	1	0	1	0	1	0	1

Bit(s)	Name	Description
31:16	P2_IN_FCOFF_THR ES	Port 2 ingress rate limit flow control off. If P2_INGRESS_FLOW_CTRL_ON = 1 and P2 Flow control capability is on (XFC status in 0x80), then P2 will initiate PAUSE OFF frame or stop backpressure.
15:0	P2_IN_FCON_THR ES	Port 2 ingress rate limit flow control on. If P2_INGRESS_FLOW_CTRL_ON = 1 and P2 Flow control capability is on (XFC status in 0x80), then P2 will initiate PAUSE ON frame or backpressure.

10110134 P3_ING_THRE Port 3 Ingress Rate Limit Threshold AAAA55
S 55

Bit	31	30	29	28	27	26	25	24	23	22	21	20	19	18	17	16
Name	P3_IN_FCOFF_THRES															
Type	RW															
Reset	1	0	1	0	1	0	1	0	1	0	1	0	1	0	1	0
Bit	15	14	13	12	11	10	9	8	7	6	5	4	3	2	1	0
Name	P3_IN_FCON_THRES															
Type	RW															
Reset	0	1	0	1	0	1	0	1	0	1	0	1	0	1	0	1

Bit(s)	Name	Description
31:16	P3_IN_FCOFF_THR ES	Port 3 ingress rate limit flow control off. If P3_INGRESS_FLOW_CTRL_ON = 1 and P3 Flow control capability is on (XFC status in 0x80), then P3 will initiate PAUSE OFF frame or stop backpressure.

Bit(s)	Name	Description
15:0	P3_IN_FCON_THRES	Port 3 ingress rate limit flow control on. If P3_INGRESS_FLOW_CTRL_ON = 1 and P3 Flow control capability is on (XFC status in 0x80), then P3 will initiate PAUSE ON frame or backpressure.

10110138 P4_ING_THRES **Port 4 Ingress Rate Limit Threshold** **AAAA55**
S **55**

Bit	31	30	29	28	27	26	25	24	23	22	21	20	19	18	17	16
Name	P4_IN_FCOFF_THRES															
Type	RW															
Reset	1	0	1	0	1	0	1	0	1	0	1	0	1	0	1	0
Bit	15	14	13	12	11	10	9	8	7	6	5	4	3	2	1	0
Name	P4_IN_FCON_THRES															
Type	RW															
Reset	0	1	0	1	0	1	0	1	0	1	0	1	0	1	0	1

Bit(s)	Name	Description
31:16	P4_IN_FCOFF_THRES	Port 4 ingress rate limit flow control off. If P4_INGRESS_FLOW_CTRL_ON = 1 and P4 Flow control capability is on (XFC status in 0x80), then P4 will initiate PAUSE OFF frame or stop backpressure.
15:0	P4_IN_FCON_THRES	Port 4 ingress rate limit flow control on. If P4_INGRESS_FLOW_CTRL_ON = 1 and P4 Flow control capability is on (XFC status in 0x80), then P4 will initiate PAUSE ON frame or backpressure.

1011013C P5_ING_THRES **Port 5 Ingress Rate Limit Threshold** **AAAA55**
S **55**

Bit	31	30	29	28	27	26	25	24	23	22	21	20	19	18	17	16
Name	P5_IN_FCOFF_THRES															
Type	RW															
Reset	1	0	1	0	1	0	1	0	1	0	1	0	1	0	1	0
Bit	15	14	13	12	11	10	9	8	7	6	5	4	3	2	1	0
Name	P5_IN_FCON_THRES															
Type	RW															
Reset	0	1	0	1	0	1	0	1	0	1	0	1	0	1	0	1

Bit(s)	Name	Description
31:16	P5_IN_FCOFF_THRES	Port 5 ingress rate limit flow control off. If P5_INGRESS_FLOW_CTRL_ON = 1 and P5 Flow control capability is on (XFC status in 0x80), then P5 will initiate PAUSE OFF frame or stop backpressure. (note: This feature is only valid when port 5 Giga MAC is implemented)
15:0	P5_IN_FCON_THRES	Port 5 ingress rate limit flow control on. If P5_INGRESS_FLOW_CTRL_ON = 1 and P0 Flow control capability is on (XFC status in 0x80), then P5 will initiate PAUSE ON frame or backpressure. (note: This feature is only valid when port 5 Giga MAC is implemented)

10110140 P01_EG_CTR **Port 0/1 Egress Rate Limit Control** **0000000**
L **0**

Bit	31	30	29	28	27	26	25	24	23	22	21	20	19	18	17	16
Name				P1_EG_RESS_CTRL	P1_TIMER_TICK											
																P1_TOKEN

Type				RW	RW		RW									
Reset				0	0	0	0	0	0	0	0	0	0	0	0	0
Bit	15	14	13	12	11	10	9	8	7	6	5	4	3	2	1	0
Name				P0_EGRESS_CTRL	P0_TIMER_TICK		P0_TOKEN									
Type				RW	RW		RW									
Reset				0	0	0	0	0	0	0	0	0	0	0	0	0

Bit(s)	Name	Description
28	P1_EGRESS_CTRL	Port 1 Egress Control 1: ON 0: OFF
27:26	P1_TIMER_TICK	Port 1 Timer Tick 0: 512us 1: 128us 2: 32us 3: 8us
25:16	P1_TOKEN	Port 1 Token Every timer tick, Token number bytes will be added into the bucket. (Unit : Byte) The maximum space of this bucket is 16'hFFFF bytes 1: ON 0: OFF
12	P0_EGRESS_CTRL	Port 0 Egress Control 0: 512us 1: 128us 2: 32us 3: 8us
11:10	P0_TIMER_TICK	Port 0 Timer Tick 1: ON 0: OFF
9:0	P0_TOKEN	Port 0 Token Every timer tick, Token number bytes will be added into the bucket. (Unit : Byte) The maximum space of this bucket is 16'hFFFF bytes

10110144 P23 EG_CTR Port 2/3 Egress Rate Limit Control 0000000
L 0

Bit	31	30	29	28	27	26	25	24	23	22	21	20	19	18	17	16
Name				P3_EGRESS_CTRL	P3_TIMER_TICK		P3_TOKEN									
Type				RW	RW		RW									
Reset				0	0	0	0	0	0	0	0	0	0	0	0	0
Bit	15	14	13	12	11	10	9	8	7	6	5	4	3	2	1	0
Name				P2_EGRESS_CTRL	P2_TIMER_TICK		P2_TOKEN									
Type				RW	RW		RW									
Reset				0	0	0	0	0	0	0	0	0	0	0	0	0

Bit(s)	Name	Description
28	P3_EGRESS_CTRL	Port 3 Egress Control

Bit(s)	Name	Description
27:26	P3_TIMER_TICK	Port 3 Timer Tick 1: ON 0: OFF
25:16	P3_TOKEN	Port 3 Token Every timer tick, Token number bytes will be added into the bucket. (Unit : Byte) The maximum space of this bucket is 16'hFFFF bytes 1: ON 0: OFF
12	P2_EGRESS_CTRL	Port 2 Egress Control 0: 512us 1: 128us 2: 32us 3: 8us
11:10	P2_TIMER_TICK	Port 2 Timer Tick 1: ON 0: OFF
9:0	P2_TOKEN	Port 2 Token Every timer tick, Token number bytes will be added into the bucket. (Unit : Byte) The maximum space of this bucket is 16'hFFFF bytes

10110148 P45 EG CTR **Port 4/5 Egress Rate Limit Control** 0000000
 0

Bit	31	30	29	28	27	26	25	24	23	22	21	20	19	18	17	16
Name				P5_EGRESS_CTRL	P5_TIMER_TICK		P5_TOKEN									
Type				RW	RW		RW									
Reset				0	0	0	0	0	0	0	0	0	0	0	0	0
Bit	15	14	13	12	11	10	9	8	7	6	5	4	3	2	1	0
Name				P4_EGRESS_CTRL	P4_TIMER_TICK		P4_TOKEN									
Type				RW	RW		RW									
Reset				0	0	0	0	0	0	0	0	0	0	0	0	0

Bit(s)	Name	Description
28	P5_EGRESS_CTRL	Port 5 Egress Control (Note: This feature is only valid when port 5 Giga MAC is implemented) 1: ON 0: OFF
27:26	P5_TIMER_TICK	Port 5 Timer Tick (Note: This feature is only valid when port 5 Giga MAC is implemented) 0: 512us 1: 128us 2: 32us 3: 8us
25:16	P5_TOKEN	Port 5 Token Every timer tick, Token number bytes will be added into the bucket. (Unit :

Bit(s)	Name	Description
		Byte) The maximum space of this bucket is 16'hFFFF bytes (Note: This feature is only valid when port 5 Giga MAC is implemented) 1: ON 0: OFF
12	P4_EGRESS_CTRL	Port 4 Egress Control 0: 512us 1: 128us 2: 32us 3: 8us
11:10	P4_TIMER_TICK	Port 4 Timer Tick 1: ON 0: OFF
9:0	P4_TOKEN	Port 4 Token Every timer tick, Token number bytes will be added into the bucket. (Unit : Byte) The maximum space of this bucket is 16'hFFFF bytes

1011014C PCRI Packet Counter Recycle Indication 0000000
0

Bit	31	30	29	28	27	26	25	24	23	22	21	20	19	18	17	16
Name	PK T_C NT_ CLR		TCOL_PKT_REC							TXOK_PKT_REC						
Type	WO		RO							RO						
Reset	0		0	0	0	0	0	0		0	0	0	0	0	0	0
Bit	15	14	13	12	11	10	9	8	7	6	5	4	3	2	1	0
Name			BAD_PKT_REC							GOOD_PKT_REC						
Type			RO							RO						
Reset			0	0	0	0	0	0		0	0	0	0	0	0	0

Bit(s)	Name	Description
31	PKT_CNT_CLR	Tx/Rx Packet Counters Write One Clear When this bit is set, all Tx/Rx packet counters will be clear. This bit can be self-clear automatically.
29:24	TCOL_PKT_REC	Per Port Transmitted Collision Packet Counter Recycle This bit indicates that the per port transmitted collision packet counter recycles the count. Write one clear.
22:16	TXOK_PKT_REC	Per Port Transmitted Good Packet Counter Recycle This bit indicates that the per port transmitted good packet counter recycles the count. Write one clear.
13:8	BAD_PKT_REC	Per Port Received Bad Packet Counter Recycle This bit indicates that the per port received bad packet counter recycles the count. Write one clear.
6:0	GOOD_PKT_REC	Per Port Received Good Packet Counter Recycle This bit indicates that the per port received good packet counter recycles the count. Write one clear.

10110150 P0TPC Port 0 TX Packet Counter 0000000
0

Bit	31	30	29	28	27	26	25	24	23	22	21	20	19	18	17	16
Name	BAD_PKT_CNT0															
Type	RO															
Reset	0	0	0	0	0	0	0	0	0	0	0	0	0	0	0	0
Bit	15	14	13	12	11	10	9	8	7	6	5	4	3	2	1	0

Name	GOOD_PKT_CNT0															
Type	RO															
Reset	0	0	0	0	0	0	0	0	0	0	0	0	0	0	0	0

Bit(s)	Name	Description
31:16	BAD_PKT_CNT0	Port 0 packet counte for transmitted packets with collisionautomatically.
15:0	GOOD_PKT_CNT0	Port 0 packet counter for transmitted packets successfully

10110154 **P1TPC** **Port 1 TX Packet Counter** **0000000**
0

Bit	31	30	29	28	27	26	25	24	23	22	21	20	19	18	17	16
Name	BAD_PKT_CNT1															
Type	RO															
Reset	0	0	0	0	0	0	0	0	0	0	0	0	0	0	0	0
Bit	15	14	13	12	11	10	9	8	7	6	5	4	3	2	1	0
Name	GOOD_PKT_CNT1															
Type	RO															
Reset	0	0	0	0	0	0	0	0	0	0	0	0	0	0	0	0

Bit(s)	Name	Description
31:16	BAD_PKT_CNT1	Port 1 packet counte for transmitted packets with collisionautomatically.
15:0	GOOD_PKT_CNT1	Port 1 packet counter for transmitted packets successfully

10110158 **P2TPC** **Port 2 TX Packet Counter** **0000000**
0

Bit	31	30	29	28	27	26	25	24	23	22	21	20	19	18	17	16
Name	BAD_PKT_CNT2															
Type	RO															
Reset	0	0	0	0	0	0	0	0	0	0	0	0	0	0	0	0
Bit	15	14	13	12	11	10	9	8	7	6	5	4	3	2	1	0
Name	GOOD_PKT_CNT2															
Type	RO															
Reset	0	0	0	0	0	0	0	0	0	0	0	0	0	0	0	0

Bit(s)	Name	Description
31:16	BAD_PKT_CNT2	Port 2 packet counte for transmitted packets with collisionautomatically.
15:0	GOOD_PKT_CNT2	Port 2 packet counter for transmitted packets successfully

1011015C **P3TPC** **Port 3 TX Packet Counter** **0000000**
0

Bit	31	30	29	28	27	26	25	24	23	22	21	20	19	18	17	16
Name	BAD_PKT_CNT3															
Type	RO															
Reset	0	0	0	0	0	0	0	0	0	0	0	0	0	0	0	0
Bit	15	14	13	12	11	10	9	8	7	6	5	4	3	2	1	0
Name	GOOD_PKT_CNT3															
Type	RO															
Reset	0	0	0	0	0	0	0	0	0	0	0	0	0	0	0	0

Bit(s)	Name	Description
31:16	BAD_PKT_CNT3	Port 3 packet counte for transmitted packets with collisionautomatically.

Bit(s)	Name	Description
15:0	GOOD_PKT_CNT3	Port 3 packet counter for transmitted packets successfully

10110160 **P4TPC** **Port 4 TX Packet Counter** **0000000**
0

Bit	31	30	29	28	27	26	25	24	23	22	21	20	19	18	17	16
Name	BAD_PKT_CNT4															
Type	RO															
Reset	0	0	0	0	0	0	0	0	0	0	0	0	0	0	0	0
Bit	15	14	13	12	11	10	9	8	7	6	5	4	3	2	1	0
Name	GOOD_PKT_CNT4															
Type	RO															
Reset	0	0	0	0	0	0	0	0	0	0	0	0	0	0	0	0

Bit(s)	Name	Description
31:16	BAD_PKT_CNT4	Port 4 packet counte for transmitted packets with collisionautomatically.
15:0	GOOD_PKT_CNT4	Port 4 packet counter for transmitted packets successfully

10110164 **P5TPC** **Port 5 TX Packet Counter** **0000000**
0

Bit	31	30	29	28	27	26	25	24	23	22	21	20	19	18	17	16
Name	BAD_PKT_CNT5															
Type	RO															
Reset	0	0	0	0	0	0	0	0	0	0	0	0	0	0	0	0
Bit	15	14	13	12	11	10	9	8	7	6	5	4	3	2	1	0
Name	GOOD_PKT_CNT5															
Type	RO															
Reset	0	0	0	0	0	0	0	0	0	0	0	0	0	0	0	0

Bit(s)	Name	Description
31:16	BAD_PKT_CNT5	Port 5 packet counte for transmitted packets with collisionautomatically. (Note: This feature is only valid when port 5 Giga MAC is implemented)
15:0	GOOD_PKT_CNT5	Port 5 packet counter for transmitted packets successfully (Note: This feature is only valid when port 5 Giga MAC is implemented)

10110168 **LEDC** **LED Control** **00E0000**
0

Bit	31	30	29	28	27	26	25	24	23	22	21	20	19	18	17	16
Name	OLT_MODE							EPHY_GPIO_8_5				EPHY_GPIO_4_0				
Type	RW							RW				RW				
Reset	0							0	1	1	1	0	0	0	0	0
Bit	15	14	13	12	11	10	9	8	7	6	5	4	3	2	1	0
Name								LED_SEL			LED_POLARITY					
Type								RW			RW					
Reset								0	0	0		0	0	0	0	0

Bit(s)	Name	Description
31	OLT_MODE	EPHY OLT Mode 0: Disable 1: Enable

Bit(s)	Name	Description
24:21	EPHY_GPIO_8_5	EPHY GPIO[8:5] EPHY_GPIO[8:5] is used to set EPHY initial state which is latched by EPHY SW reset.
20:16	EPHY_GPIO_4_0	EPHY GPIO[4:0] EPHY_GPIO[4:0] is used to set EPHY MDIO address which is latched by EPHY SW reset.
10:8	LED_SEL	LED Source 0: ESW LED Control 1: EPHY LED Control[0] 2: EPHY LED Control[1] 3: EPHY LED Control[2]
4:0	LED_POLARITY	Per Port LED Polarity Control 0: Low Active 1: High Active

6. Abbreviations

Abbrev.	Description
AC	Access Category
ACK	Acknowledge/ Acknowledgement
ACPR	Adjacent Channel Power Ratio
AD/DA	Analog to Digital/Digital to Analog converter
ADC	Analog-to-Digital Converter
AES	Advanced Encryption Standard
AGC	Auto Gain Control
AIFS	Arbitration Inter-Frame Space
AIFSN	Arbitration Inter-Frame Spacing Number
ALC	Asynchronous Layered Coding
A-MPDU	Aggregate MAC Protocol Data Unit
A-MSDU	Aggregation of MAC Service Data Units
AP	Access Point
ASIC	Application-Specific Integrated Circuit
ASME	American Society of Mechanical Engineers
ASYNC	Asynchronous
BA	Block Acknowledgement
BAC	Block Acknowledgement Control
BAR	Base Address Register
BBP	Baseband Processor
BGSEL	Band Gap Select
BIST	Built-In Self-Test
BSC	Basic Spacing between Centers
BJT	
BSSID	Basic Service Set Identifier
BW	Bandwidth
CCA	Clear Channel Assessment
CCK	Complementary Code Keying
CCMP	Counter Mode with Cipher Block Chaining Message Authentication Code Protocol
CCX	Cisco Compatible Extensions
CF-END	Control Frame End
CF-ACK	Control Frame Acknowledgement
CLK	Clock
CPU	Central Processing Unit
CRC	Cyclic Redundancy Check
CSR	Control Status Register
CTS	Clear to Send

Abbrev.	Description
CW	Contention Window
CWmax	Maximum Contention Window
CWmin	Minimum Contention Window
DAC	Digital-To-Analog Converter
DCF	Distributed Coordination Function
DDONE	DMA Done
DDR	Double Data Rate
DFT	Discrete Fourier Transform
DIFS	DCF Inter-Frame Space
DMA	Direct Memory Access
DSP	Digital Signal Processor
DW	DWORD
EAP	Expert Antenna Processor
EDCA	Enhanced Distributed Channel Access
EECS	EEPROM chip select
EEDI	EEPROM data input
EEDO	EEPROM data output
EEPROM	Electrically Erasable Programmable Read-Only Memory
eFUSE	electrical Fuse
EESK	EEPROM source clock
EIFS	Extended Inter-Frame Space
EIV	Extend Initialization Vector
EVM	Error Vector Magnitude
FDS	Frequency Domain Spreading
FEM	Front-End Module
FEQ	Frequency Equalization
FIFO	First In First Out
FSM	Finite-State Machine
GF	Green Field
GND	Ground
GP	General Purpose
GPO	General Purpose Output
GPIO	General Purpose Input/Output
HCCA	HCF Controlled Channel Access
HCF	Hybrid Coordination Function
HT	High Throughput
HTC	High Throughput Control
ICV	Integrity Check Value
IFS	Inter-Frame Space
iNIC	Intelligent Network Interface Card
IV	Initialization Vector
I ² C	Inter-Integrated Circuit
I ² S	Integrated Inter-Chip Sound

Abbrev.	Description
I/O	Input/Output
IPI	Idle Power Indicator
IQ	In phase/Quadrature phase
JEDEC	Joint Electron Devices Engineering Council
JTAG	Joint Test Action Group
kbps	kilo (1000) bits per second
KB	Kilo (1024) Bytes
LDO	Low-Dropout Regulator
LDODIG	LDO for DIGital part output voltage
LED	Light-Emitting Diode
LNA	Low Noise Amplifier
LO	Local Oscillator
L-SIG	Legacy Signal Field
MAC	Medium Access Control
MCU	Microcontroller Unit
MCS	Modulation and Coding Scheme
MDC	Management Data Clock
MDIO	Management Data Input/Output
MEM	Memory
MFB	MCS Feedback
MFS	MFB Sequence
MIC	Message Integrity Code
MIMO	Multiple-Input Multiple-Output
MLNA	Monolithic Low Noise Amplifier
MM	Mixed Mode
MOSFET	Metal Oxide Semiconductor Field Effect Transistor
MPDU	MAC Protocol Data Units
MSB	Most Significant Bit
NAV	Network Allocation Vector
NAS	Network-Attached Server
NAT	Network Address Translation
NDP	Null Data Packet
NVM	Non-Volatile Memory
ODT	On-die Termination
Oen	Output Enable
OFDM	Orthogonal Frequency-Division Multiplexing
OSC	Open Sound Control
PA	Power Amplifier
PAPE	Provider Authentication Policy Extension
PBC	Push Button Configuration
PBF	Packet Buffer

Abbrev.	Description
PCB	Printed Circuit Board
PCF	Point Coordination Function
PCM	Pulse-Code Modulation
PHY	Physical Layer
PIFS	PCF Interframe Space
PLCP	Physical Layer Convergence Protocol
PLL	Phase-Locked Loop
PME	Physical Medium Entities
PMU	Power Management Unit
PN	Packet Number
PROM	Programmable Read-Only Memory
PSDU	Physical layer Service Data Unit
PSI	Power supply Strength Indication
PSM	Power Save Mode
PTN	Packet Transport Network
QoS	Quality of Service
RDG	Reverse Direction Grant
RAM	Random Access Memory
RF	Radio Frequency
RGMII	Reduced Gigabit Media Independent Interface
RH	Relative Humidity
RoHS	Restriction on Hazardous Substances
ROM	Read-Only Memory
RSSI	Received Signal Strength Indication (Indicator)
RTS	Request to Send
RvMII	Reverse Media Independent Interface
Rx	Receive
RXD	Received Data
RXINFO	Receive Information
RXWI	Receive Wireless Information
S	Stream
SDXC	Secure Digital eXtended Capacity
SDIO	Secure Digital Input Output
SDRAM	Synchronous Dynamic Random Access Memory
SEC	Security
SGL	Short Guard Interval
SIFS	Short Inter-Frame Space
SoC	System-on-a-Chip
SPI	Serial Peripheral Interface
SRAM	Static Random Access Memory
SSCG	Spread Spectrum Clock Generator
STBC	Space-Time Block Code

Abbrev.	Description
SW	Switch Regulator
TA	Transmitter Address
TBTT	Target Beacon Transmission Time
TDLS	Tunnel Direct Link Setup
TKIP	Temporal Key Integrity Protocol
TRSW	Tx/Rx Switch
TSF	Timing Synchronization Function
TSSI	Transmit Signal Strength Indication
Tx	Transmit
TxBF	Transmit Beamforming
TXD	Transmitted Data
TXDAC	Transmit Digital-Analog Converter
TXINFO	Transmit Information
TXOP	Opportunity to Transmit
TXWI	Tx Wireless Information
UART	Universal Asynchronous Rx/ Tx
USB	Universal Serial Bus
UTIF	Universal Test Interface
VGA	Variable Gain Amplifier
VCO	Voltage Controlled Amplifier
VIH	High Level Input Voltage
VIL	Low Level Input Voltage
VoIP	Voice over IP
WCID	Wireless Client Identification
WEP	Wired Equivalent
WI	Wireless Information
WIV	Wireless Information Valid
WMM	Wi-Fi Multimedia
WPA	Wi-Fi Protected Access
WPDMA	Wireless Polarization Division Multiple Access
WS	Word Select

This product is not designed for use in medical and/or life support applications. Do not use this product in these types of equipment or applications. This document is subject to change without notice and Ralink assumes no responsibility for any inaccuracies that may be contained in this document. Ralink reserves the right to make changes in its products to improve function, performance, reliability, and to attempt to supply the best product possible.