



# MT7813B

## High Efficiency High Precision Buck Constant Current Driver

### DESCRIPTION

MT7813B is a high precision LED constant current controller operating at critical conduction mode (CRM) with zero current switched-on and peak current switched-off. It's mainly targeted for non-isolated buck LED power systems.

Critical conduction mode ensures that the MT7813B turns on the internal power MOSFET when the inductor current reaches zero, reducing the power MOSFET switching loss, and achieving more than 95% efficiency. With critical conduction mode, and the input compensation, MT7813B can achieve precise output current and excellent line regulation and load regulation.

MT7813B embedded with internal power MOSFET, it can achieve simplified peripheral circuits and low BOM cost.

MT7813B has wide working voltage range, which is suitable for full-range AC input. MT7813B provides various protection features to improve the system reliability, including over current protection (OCP), short circuit protection (SCP), adjustable over voltage protection (OVP) and thermal adjustment, etc.

### FEATURES

- Critical Conduction Mode, insensitive to the inductance.
- High efficiency (up to 95%)
- Highly accurate constant LED current
- Cycle-by-cycle current limiting
- LED short circuit protection
- Adjustable OVP through external resistor
- Leading edge blanking technique
- Under-voltage lockout (UVLO) protection
- Thermal adjustment
- Available in SOP8 / DIP7 package

### APPLICATIONS

- LED bulb, LED tube, LED signal and landscape lamp
- LED stage light, LED candle light, LED corn light, etc.
- General purpose constant current source

### Typical Application Circuit

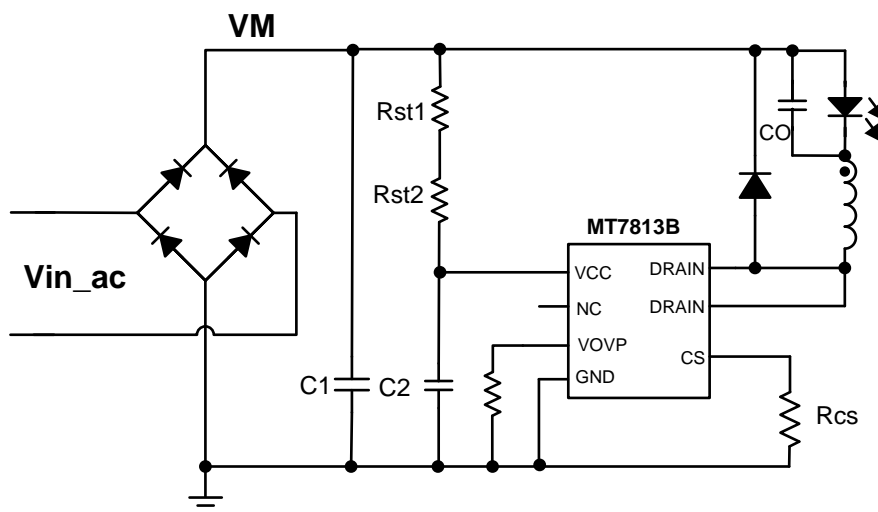



# MT7813B

**High Efficiency High Precision Buck Constant Current Driver**

## ABSOLUTE MAXIMUM RATINGS

VCC maximum sink current	5mA
VOVP (over voltage protection pin voltage)	-0.3 ~ 6V
DRAIN (internal HV power MOS drain voltage)	-0.3V ~ 500V
SOURCE (internal HV power MOS source voltage)	-0.3 ~ 40V
CS (current sense pin input voltage)	-0.3V ~ 6V
P <sub>DMAX</sub> (maximum power dissipation )	0.8W(SOP8); 1.2W (DIP7)
Storage Temperature range	-55°C ~ 150°C
Junction Temperature (T <sub>j</sub> )	150°C

## RECOMMENDEDE OPERATING CONDITIONS

Operating Temperature	-40°C ~ 105°C
Output Current (SOP8)	<300mA
Output Current (DIP7)	<360mA

## ORDERING INFORMATION

Device	Package
MT7813BS	SOP8
MT7813BD	DIP7

## PIN CONFIGURATIONS

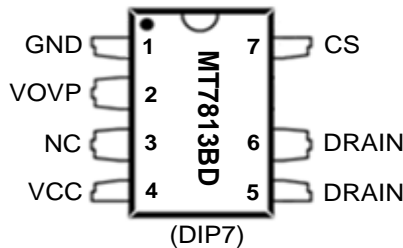
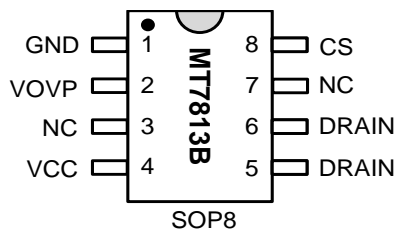

### Chip Mark

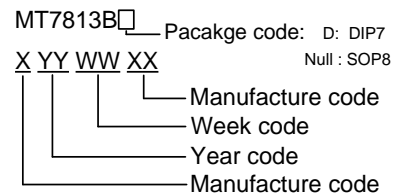

## PIN DESCRIPTION

Name	Pin No. SOP8	Pin No. DIP7	Description
GND	1	1	Chip ground
VOVP	2	2	Over voltage protection pin
NC	3	3	No connection
VCC	4	4	Power supply, internal clamped at 15.5V
DRAIN	5/6	5/6	Drain of internal high-voltage power MOSFET
NC	7		No connection
CS	8	7	Current sense input, connect a sense resistor to ground

**ELECTRICAL CHARACTERISTICS**

(Test condition: VCC=13V, TA=25°C unless otherwise stated.)

Symbol	Parameter		Min	Typ	Max	Unit
<b>Start-up and supply voltage (VCC Pin)</b>						
I <sub>START</sub>	Start up current	V <sub>CC</sub> < V <sub>CC_UV</sub>		120	180	μA
V <sub>CC_UV</sub>	Lower threshold Voltage of V <sub>CC</sub> (UVLO)	V <sub>CC</sub> Pin ramp down		5.5		V
V <sub>START</sub>	Start-up voltage	V <sub>CC</sub> Pin ramp up		12		V
V <sub>CC-CLAMP</sub>	V <sub>CC</sub> Clamping voltage	I <sub>DD</sub> <5mA		15.5		V
<b>Supply current</b>						
I <sub>op</sub>	Operating current			0.3		mA
<b>Current sense (CS Pin)</b>						
V <sub>CS-TH</sub>	Threshold voltage for peak current limit		390	400	410	mV
LEB1	Leading edge blanking time for current sense			500		ns
<b>Thermal Protection</b>						
T <sub>ADJ</sub>	Thermal adjustment temperature			150		°C
<b>Driver Circuit</b>						
T <sub>OFF_MIN</sub>	Minimum OFF time			1.5		us
T <sub>OFF_MAX</sub>	Maximum OFF time			400		us
T <sub>ON_MAX</sub>	Maximum ON time			55		us
<b>High-voltage Power MOSFET (DRAIN/SOURCE)</b>						
R <sub>DS(on)</sub>	Static drain-source on-resistance	V <sub>GS</sub> =10V/I <sub>DS</sub> =1.25A		5.5		Ω
BV <sub>DSS</sub>	Drain-source breakdown voltage	V <sub>GS</sub> =0V/I <sub>DS</sub> =250uA	500			V



# MT7813B

## High Efficiency High Precision Buck Constant Current Driver

### BLOCK DIAGRAM

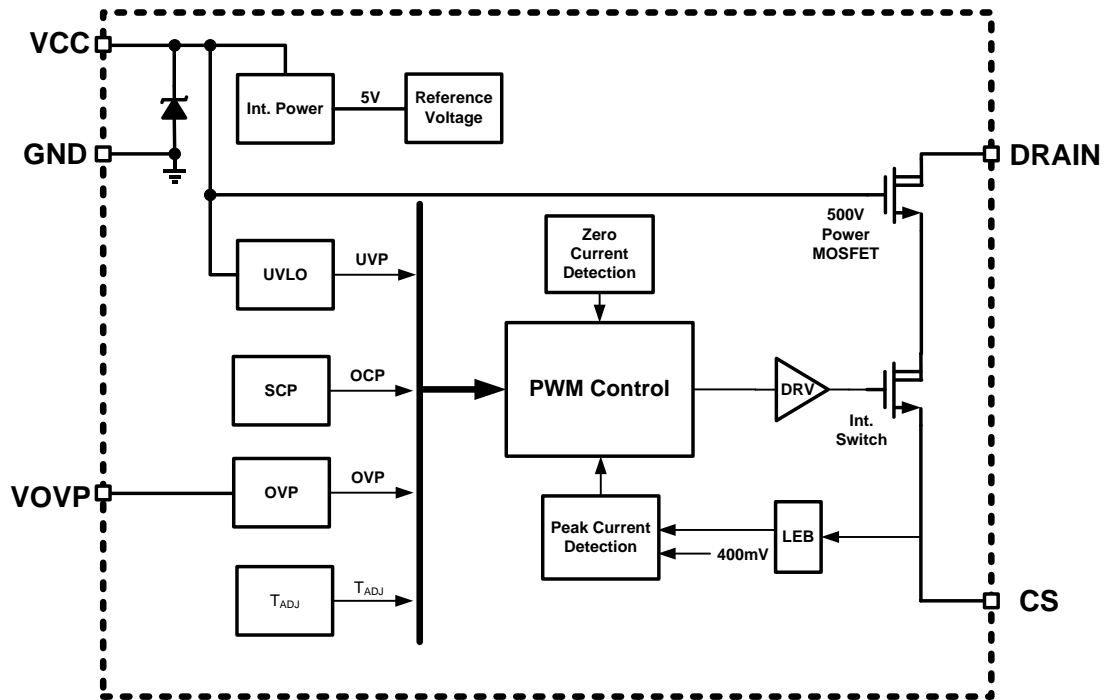

### APPLICATION INFORMATION

MT7813B is a constant current driver with built-in 500V power MOSFET. It works under critical conduction mode, and switches on the power MOSFET at inductor current is zero, which improves efficiency and reduces the power MOSFET switching loss. MT7813B is specially designed for LED lighting applications, simplified peripheral circuits and low BOM cost is achieved.

#### Start up

VCC is charged through the start-up resistor once the system is powered on. As the VCC reaches 12V, the control logic starts to work, and internal switch starts toggling. When the VCC rises up to 15.5V, it will be clamped. MT7813B shuts down as VCC falls below 5.5V.

#### CRM and Output Current Setup

The internal power MOSFET current is cycle-by-cycle detected by monitoring the voltage

on the CS pin. When the voltage reaches 400mV (internal reference voltage), the internal power MOSFET is turned off, when the inductor current drops to zero, it will be turned on again.

The peak inductor current is given by:

$$I_{LPK} = \frac{400}{R_{CS}} (mA) \quad (1)$$

Where,  $R_{CS}$  is the current sense resistor in ohm. The CS comparator also includes a 500ns leading edge blanking time to block the transient noise as the power switch just turned on.

The current at LED can be calculated as:

$$I_{LED} = \frac{I_{LPK}}{2} = \frac{400mV}{2 \times R_{CS}} (mA) \quad (2)$$

Where,  $I_{LPK}$  is the peak current of the inductor. Shown in the equation above, the output current is determined by the  $R_{CS}$  and the 400mV reference voltage, insensitive to the inductance.



# MT7813B

## High Efficiency High Precision Buck Constant Current Driver

### Switching Frequency

MT7813B operates under critical conduction mode. When the inductor current is zero, the system turns on the internal power MOSFET, the inductor current rises up from the ground. The on time of the power MOSFET is calculated by the equation:

$$T_{ON} = \frac{L \times I_{LPK}}{V_{IN} - V_{LED}} \quad (3)$$

Where, L is the inductance of the inductor;  
 $I_{LPK}$  is the peak current through the inductor;  
 $V_{IN}$  is the DC voltage of the rectified input voltage;  
 $V_{LED}$  is the forward voltage drop of the LED.  
 The internal power MOSFET is turned off, while the voltage on the CS pin increases to 400mV. The inductor current will discharge the LED through the free-wheeling diode. The internal power MOSFET won't be turned on until the current in the inductor drops to zero. The off time of the power MOSFET is calculated by the equation:

$$T_{OFF} = \frac{L \times I_{LPK}}{V_{LED}} \quad (4)$$

Operating frequency of the system is:

$$f = \frac{1}{T_{ON} + T_{OFF}} = \frac{V_{LED} \times (1 - \frac{V_{LED}}{V_{IN}})}{L \times I_{LPK}} \quad (5)$$

From the equation, it's showing that MT7813B operating frequency is determined by the input voltage  $V_{IN}$ , the LED forward voltage drop  $V_{LED}$  and the inductance L. The higher input voltage  $V_{IN}$  makes the operating frequency to be higher. For both EMI and efficiency consideration, it's recommended to set the operating frequency between 30kHz ~ 80kHz. The appropriate inductance should be determined at minimum input voltage condition to meet the requirement.

MT7813B sets the maximum off-time  $T_{OFF\_MAX}=400\mu s$ , the minimum off-time

$T_{OFF\_MIN}=1.5\mu s$ . Shown in  $T_{OFF}$  equation, if the inductance is too large,  $T_{OFF}$  maybe longer than  $T_{OFF\_MAX}$ , the system will turn on the switch before the inductor current falls to zero, after five times consecutive  $T_{OFF\_MAX}$  cycles, the system enters hiccup and re-start status. On the contrary, if inductance is too small,  $T_{OFF}$  may be shorter than  $T_{OFF\_MIN}$ , then the inductor current has already been reduced to zero before the next cycle starts, the system enters discontinuous mode. So it's important to choose a proper inductance.

Maxic provides design tool of this chip, it helps customer to come out proper solution and to choose the right inductance.

### LED Over voltage protection setup

The OVP threshold of MT7813B is adjustable through the resistor  $R_{SET}$ . (Refer to Fig.1.).

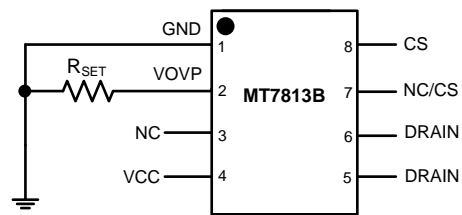

**Fig.1 OVP setup**

The OVP threshold can be calculated as:

$$V_{OVP} = \frac{2.6 \times L \times R_{SET}}{R_{CS}} \quad (V) \quad (6)$$

Where, L is in mH;  $R_{CS}$  is in ohm;  $R_{SET}$  is in Kohm.

### Consideration for OVP Setup:

- 1) Considering the accuracy of the inductor, the calculated value of OVP threshold by Equation above may not exactly match the real value. It is highly recommended to set the OVP threshold to be 1.3 times of the maximum LED voltage. Otherwise it may false trigger the OVP protection during normal operation, resulting in flickering.
- 2) The OVP pin can be floated. If this pin is left



# MT7813B

## High Efficiency High Precision Buck Constant Current Driver

floating, the OVP function will be not available.

- 3) If the voltage of the inductor is relatively small, the system will enter MAXON status. Thus, the real  $I_{LPK}$  will be lower than the calculated value, and the demagnetization time will be reduced, when the demagnetization time decreased to lower than the OVP setting value, the system will trigger OVP protection. This can be avoided through increasing the input capacitor or increasing the OVP threshold.

### Over-current Protection

MT7813B immediately turns off the internal switch and power MOSFET once the voltage on CS pin exceeds 400mV. This cycle-by-cycle current limitation scheme prevents the relevant components, such as power MOSFET, transformer, etc. suffers from damage.

### Other Protection Features

MT7813B provides various protections, such as LED short-circuit protection, current sense resistor open-circuit protection and current sense resistor short-circuit protection, etc.

When the LED short-circuit or current sense resistor short-circuit is detected, MT7813B immediately enters short-circuit protection status, ceasing switch toggling, discharging the VCC capacitor simultaneously. Finally, the system gets into the hiccups-restart mode and consumes very low power. Once the short-circuit condition is removed, the system automatically resumes to normal working status.

### Thermal adjustment

The MT7813B integrates thermal adjustment function to monitor the IC junction temperature. When the system is over heated, the output current is gradually reduced and so as the output power and thermal dissipation. This way the system temperature is adjusted in the reliable range. The thermal adjustment temperature is 150°C.

### PCB Layout Consideration

- 1) The VCC de-coupling capacitor (typically 1uF ~ 4.7uF ceramic capacitor) should be kept as close to the VCC pin as possible (no more than 5mm). This can greatly improve the system noise immunity.
- 2) The pin5, pin6 are the drain of the high-voltage power MOSFET. They are the major noise disturbance source. Must put GND plane under the chip to shield the drain terminal with other pins.
- 3) The VOVP connection wire and the related resistor terminals must be placed far away with the high voltage components, such as the MOSFET drain (Pin5, Pin6). The connection wire should be as short as possible.

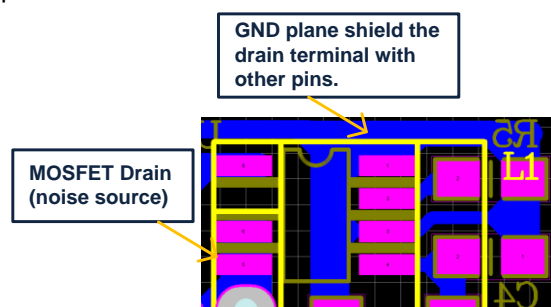



# MT7813B

High Efficiency High Precision Buck Constant Current Driver

## PACKAGE INFORMATION

### SOP8 PACKAGE OUTLINE AND DIMENSIONS

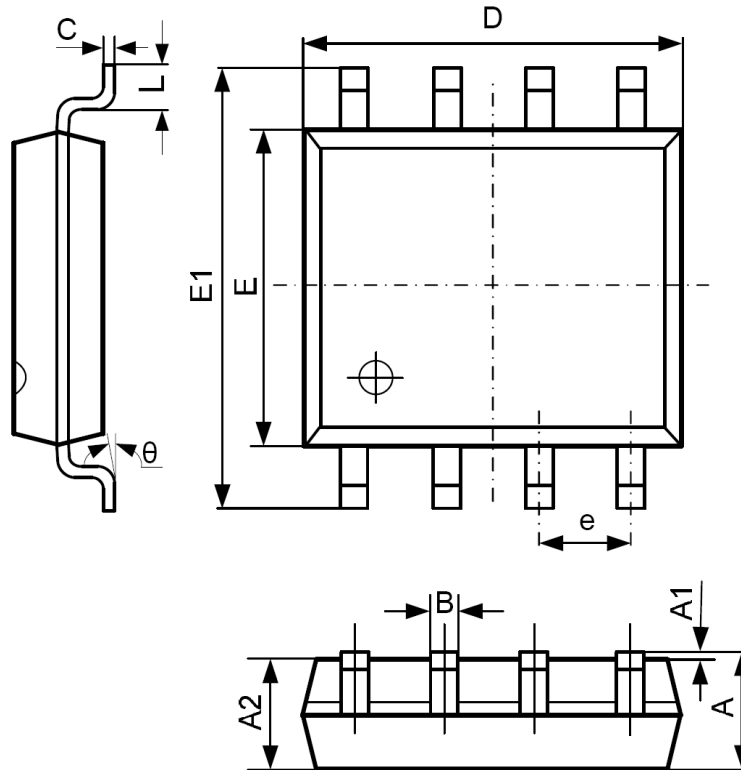

SYMBOL	DIMENSION IN MILLIMETERS		DIMENSION IN INCHES	
	MIN	MAX	MIN	MAX
A	1.350	1.750	0.053	0.069
A1	0.100	0.250	0.004	0.010
A2	1.350	1.550	0.053	0.061
B	0.330	0.510	0.013	0.020
C	0.190	0.250	0.007	0.010
D	4.700	5.100	0.185	0.201
E	3.800	4.000	0.150	0.157
E1	5.800	6.300	0.228	0.248
e	1.270 TYP		0.050 TYP	
L	0.400	1.270	0.016	0.050
θ	0°	8°	0°	8°



**MT7813B**  
**High Efficiency High Precision Buck Constant Current Driver**

**DIP7 PACKAGE OUTLINE AND DIMENSIONS**

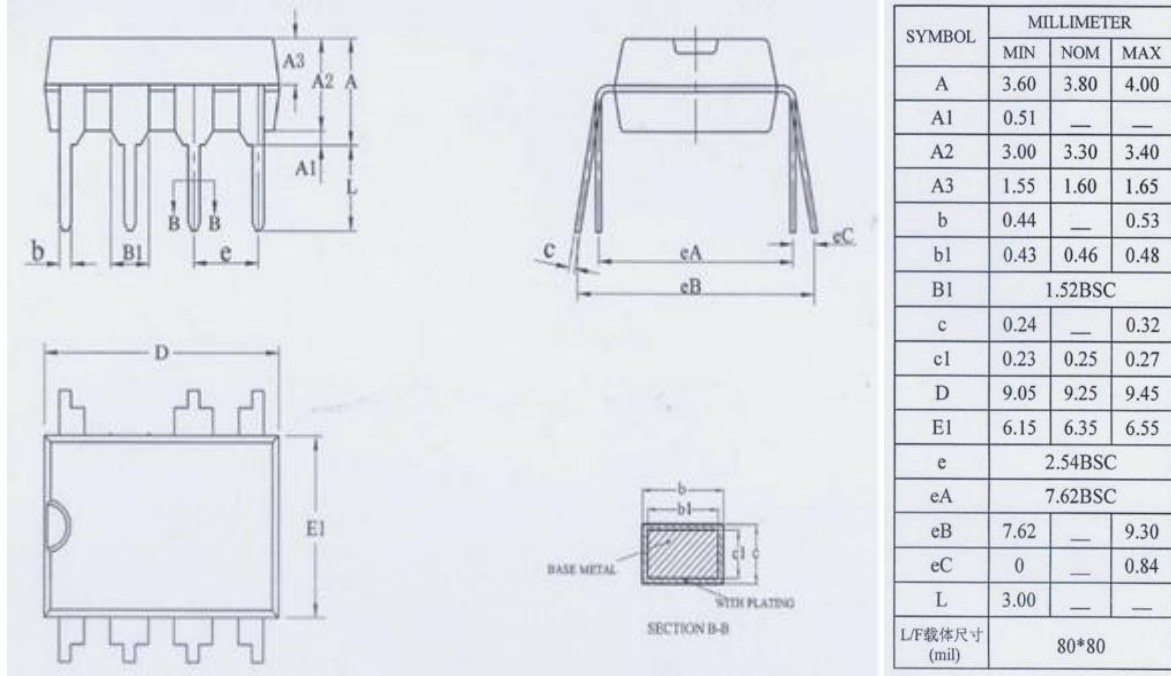

**Important Notice**

- Maxic Technology Corporation (Maxic) reserve the right to make correction, modifications, enhancements, improvements and other changes to its products and services at any time and to discontinue any product or service without notice. Customers should obtain the latest relevant information before placing orders and should verify that such information is current and complete. All products are sold subject to Maxic's terms and conditions of sale supplied at the time of order acknowledgement.
- Reproduction, copying, transferring, reprinting this paper without Maxic's written permission is prohibited.
- Maxic is not responsible or liable for customer product design by using Maxic components. To minimize the risks and associated with customer products and applications, customers should provide adequate design and operating safeguards and consult Maxic's sales department.