

### DESCRIPTION

MT7816B is a high precision LED constant current controller operating at critical conduction mode (CRM) with zero current switched-on and peak current switched-off. It's mainly targeted for non-isolated buck LED power systems and PWM/Analog dimmable application.

Critical conduction mode ensures that the MT7816B turns on the internal switch when the inductor current reaches zero, reducing the switch-on switching losses, and achieving more than 93% efficiency.

With critical conduction mode, and the input compensation, MT7816B outputs high accuracy LED current, and further achieves excellent line regulation and load regulation.

MT7816B has wide working voltage range, which is suitable for full-range AC input or 12V ~ 500V DC input voltage. MT7816B provides various protection features to improve the system reliability, including over current protection (OCP), short circuit protection (SCP), adjustable over voltage protection (OVP) and over temperature regulation (OTR), etc.

### FEATURES

- Internal 500V power MOSFET
- Critical Conduction Mode, insensitive to the inductance
- PWM/ Analog dimming function
- High efficiency (up to 93%)
- Highly accurate constant LED current
- Cycle-by-cycle current limiting
- LED short circuit protection
- Adjustable LED over voltage protection
- Leading edge blanking technique
- Under-voltage lockout (UVLO) protection
- Over temperature regulation (OTR)
- Available in SOP8 / DIP7package

### APPLICATIONS

- LED tube, signal lamp, landscape lamp
- LED stage light, etc
- Intelligent LED lighting application

### Typical Application Circuit

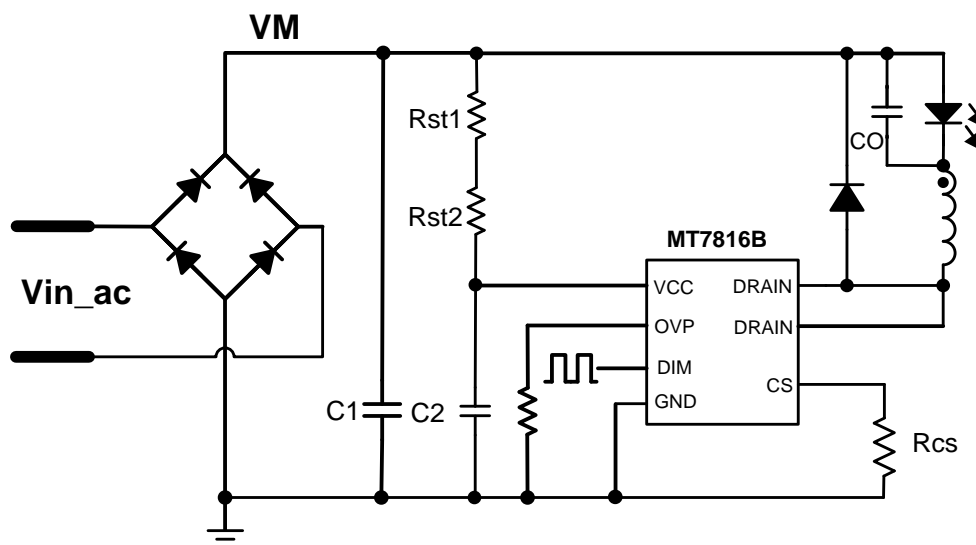

**ABSOLUTE MAXIMUM RATINGS**

VCC maximum sink current	5mA
DRAIN (internal HV power MOSFET drain voltage)	-0.3V ~ 500V
DIM (PWM/Analog dimming pin input voltage)	-0.3V ~ 6V
OVP (over voltage protection pin input voltage)	-0.3V ~ 6V
CS (current sense pin input voltage)	-0.3V ~ 6V
P <sub>DMAX</sub> (maximum power dissipation)	0.8W (SOP8); 1.2W (DIP7)
Storage Temperature range	-55°C ~ 150°C
Junction Temperature(T <sub>j</sub> )	150°C

**RECOMMENDEDE OPERATING CONDITIONS**

Operating Temperature range	-40°C ~ 105°C
Output Current ( SOP8)	<300mA
Output Current ( DIP7)	<360mA

**ORDERING INFORMATION**

Device	Package
MT7816B	SOP8
MT7816BD	DIP7

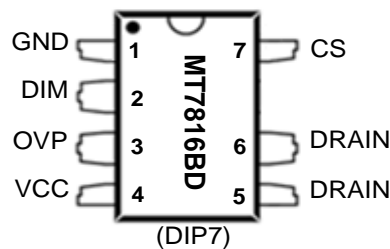
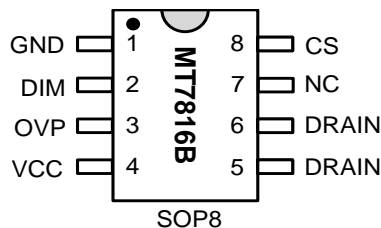
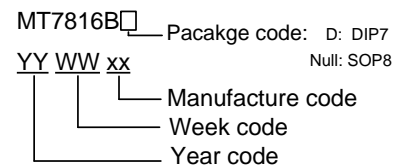
**PIN CONFIGURATIONS**

**Chip Mark**

**PIN DESCRIPTION**

Name	Pin No. SOP8	Pin No. DIP7	Description
GND	1	1	Ground
DIM	2	2	Chip enable/ PWM dimming /analog dimming Internal has a 300K pull_up resistor, this pin can be floating
OVP	3	3	Adjustable over voltage protection pin
VCC	4	4	Power supply pin, internal clamped at 14V
DRAIN	5/6	5/6	Drain of internal high-voltage power MOSFET
NC	7		No connection
CS	8	7	Current sense input, connect a sense resistor to ground



# MT7816B

## PWM/Analog dimmable Non-isolated Constant Current LED Driver

### ELECTRICAL CHARACTERISTICS

(Test condition: VCC=13V, TA=25°C unless otherwise stated.)

Symbol	Parameter		Min	Typ	Max	Unit
<b>Start-up and supply voltage (VCC Pin)</b>						
I <sub>START</sub>	Start up current	V <sub>CC</sub> < V <sub>CC_UV</sub>		220	260	μA
V <sub>CC_UV</sub>	Under Voltage Lockout (UVLO)	V <sub>CC</sub> Pin ramp down		6.5		V
V <sub>START</sub>	Start-up voltage	V <sub>CC</sub> Pin ramp up		11.5		V
V <sub>CC-CLAMP</sub>	V <sub>CC</sub> Clamp voltage	I <sub>DD</sub> <5mA		14		V
<b>Supply current</b>						
I <sub>op</sub>	Operating current			0.35		mA
<b>Current sense (CS Pin)</b>						
V <sub>CS-TH</sub>	Threshold voltage for peak current limit		390	400	410	mV
LEB1	Leading edge blanking time for current sense			500		ns
<b>DIM dimming (DIM Pin)</b>						
V <sub>DIM_floating</sub>	DIM pin floating			5		V
R <sub>DIM_Pullup</sub>	DIM pin floating			300K		Ω
V <sub>DIM_EN</sub>	Chip enable threshold (Enable: V <sub>DIM</sub> > V <sub>DIM_EN</sub> )		0.5		0.7	V
V <sub>DIM_ON</sub>	The turn on threshold for PWM dimming			2.5		V
V <sub>DIM_ANALOG</sub>	Analog dimming range		0.7		1.6	V
<b>Over Temperature Regulation</b>						
OTR	Thermal regulation temperature			155		°C
<b>Driver Circuit</b>						
T <sub>OFF_MIN</sub>	Minimum OFF time	DIM pin floating		2.5		us
T <sub>OFF_MAX</sub>	Maximum OFF time			400		us
T <sub>ON_MAX</sub>	Maximum ON time			40		us
<b>High-voltage Power MOSFET (DRAIN Pin)</b>						
R <sub>DSON</sub>	Static drain-source on-resistance	V <sub>GS</sub> =10V/I <sub>D</sub> =1.25A		5.5		Ω
BV <sub>DSS</sub>	Breakdown voltage	V <sub>GS</sub> =0V/I <sub>D</sub> =250uA	500			V
I <sub>DSS</sub>	Leakage current	V <sub>GS</sub> =0V/V <sub>DS</sub> =500V			10	uA

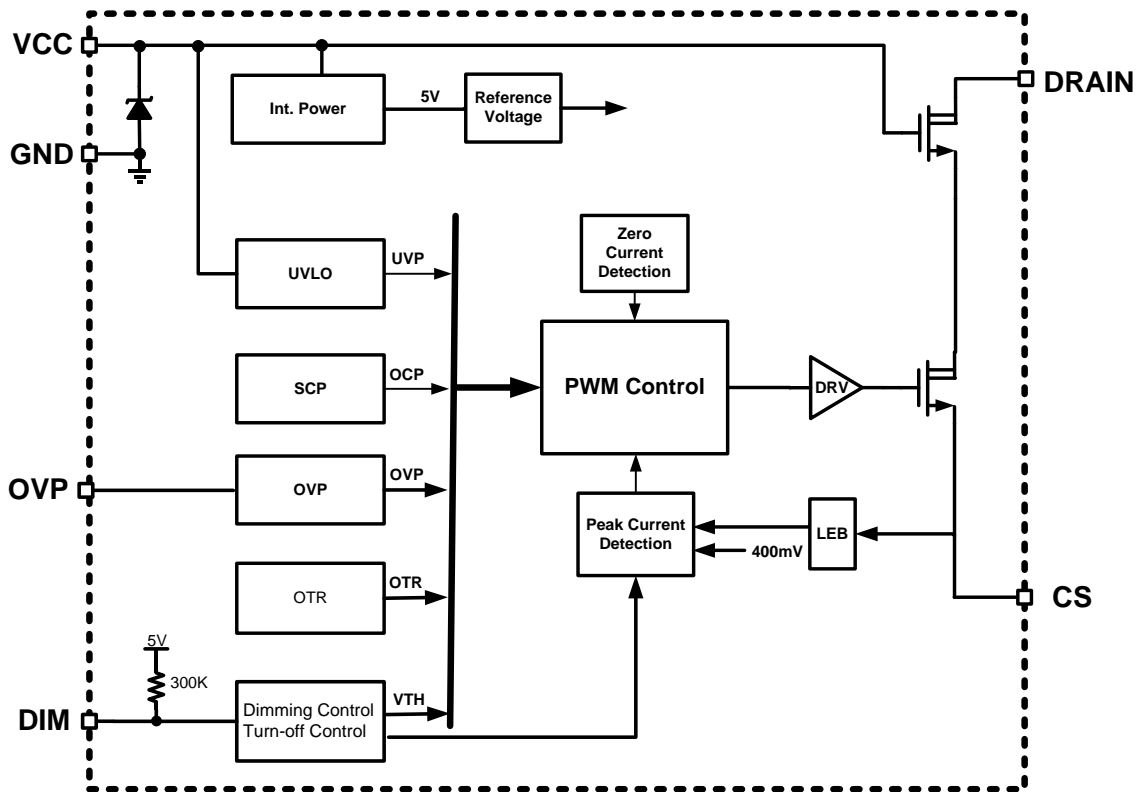
**BLOCK DIAGRAM**

**APPLICATION INFORMATION**

MT7816B is a constant current driver, designed for non-isolated buck applications with PWM/ analog dimming function.

MT7816B works under critical conduction mode, switches on the internal switch at inductor current is zero. This way improves efficiency and reduces the switch-on switching loss. With very few peripheral components, the MT7816B achieves excellent constant current control.

**Start up**

During start-up, VCC is charged through the start-up resistor. As VCC reaches 11.5V, the control logic starts to work, and internal switch starts toggling. When the VCC rises up to 14V, it will be clamped. MT7816B shuts down as VCC falls below 6.5V.

**CRM and Output Current Setup**

The internal switch current is cycle-by-cycle detected by monitoring the CS pin voltage. When the voltage on CS pin reaches 400mV (internal reference voltage), the internal switch is turned off. When the inductor current drops to zero, the system turns on the internal switch again.

The peak inductor current is given by:

$$I_{LPK} = \frac{400}{R_{CS}}(mA) \quad (1)$$

Where,  $R_{CS}$  is the current sense resistor in ohm. The CS comparator also includes a 500ns leading edge blanking time to block the transient noise as the power switch just turned on.

The current at LED can be calculated as:

$$I_{LED} = \frac{I_{LPK}}{2} = \frac{400mV}{2 \times R_{CS}} (mA) \quad (2)$$

Where,  $I_{LPK}$  is the peak current through the inductor. Shown in the above equation, the output current is determined by the  $R_{CS}$  and the 400mV reference voltage, insensitive to the inductance.

### Switching Frequency

MT7816B operates at critical conduction mode. When the inductor current is zero, the system turns on the internal switch, the inductor current rises up from the ground. The on time of the internal switch is calculated by the equation:

$$T_{ON} = \frac{L \times I_{LPK}}{V_{IN} - V_{LED}} \quad (3)$$

Where, L is the inductance of the inductor;  
 $I_{LPK}$  is the peak current through the inductor;  
 $V_{IN}$  is the DC voltage of the rectified input voltage;  
 $V_{LED}$  is the forward voltage drop of the LED.  
 The internal switch is switched off, while the voltage on the CS pin increases to 400mV. The inductor current will discharge the LED through the free-wheeling diode. The internal switch won't be turned on until the current in the inductor drops to zero. The off time of the internal switch is calculated by the equation:

$$T_{OFF} = \frac{L \times I_{LPK}}{V_{LED}} \quad (4)$$

Operating frequency of the system is:

$$F = \frac{1}{T_{ON} + T_{OFF}} = \frac{V_{LED} \times (1 - \frac{V_{LED}}{V_{IN}})}{L \times I_{LPK}} \quad (5)$$

From the above equation, it's showing that MT7816B operating frequency is determined by the input voltage  $V_{IN}$ , the LED forward voltage

drop  $V_{LED}$  and the inductance L. The higher input voltage  $V_{IN}$  makes the operating frequency to be higher. The appropriate inductance should be determined at minimum input voltage condition to meet the requirement:

- 1) For both EMI and efficiency consideration, set the operating frequency between 30kHz ~80kHz.
- 2) It's recommended to set the minimum operating frequency to be higher than 40kHz at lowest input voltage condition to achieve better PWM dimming effect.

MT7816B sets the maximum off-time  $T_{OFF\_MAX}=400\mu s$ , the minimum off-time  $T_{OFF\_MIN}=2.5\mu s$ . Shown in  $T_{OFF}$  equation, if the inductance is too large,  $T_{OFF}$  maybe longer than  $T_{OFF\_MAX}$ , the system will turn on the switch before the inductor current falls to zero, the system will operate in continuous conduction mode and the output current will be higher than the designed value. On the contrary, if inductance is too small, the  $T_{OFF}$  may be shorter than  $T_{OFF\_MIN}$ , the system enters OVP protection status. So it's important to choose a proper inductance.

### Analog Dimming Application

The DIM pin can be driven by an external DC voltage to adjust the average output current by adjusting the internal reference voltage.

Analog dimming range is about 0.7V to 1.6V. The dimming curve is shown in Fig.2.

The average output current can be calculated as:

$$I_{LED} = 0.5 \times \frac{(400 - 400 \times (1.6V - V_{DIM}))mV}{R_{CS}} \quad (6)$$

Where,  $0.7V \leq V_{DIM} \leq 1.6V$

As  $V_{DIM}$  in the range of 1.7V to 5V ( $1.7V \leq V_{DIM} \leq 5V$ ), the output current  $I_{LED}$  keeps as the maximum value.

There are two methods for analog dimming:

- 1) Input analog level directly. The DC voltage can be adjusted by a potentiometer to generate a variable analog signal on DIM pin.
- 2) Using PWM signal to generate analog signal by connecting a Low-Pass RC filter to DIM pin. Refer to Fig.1.

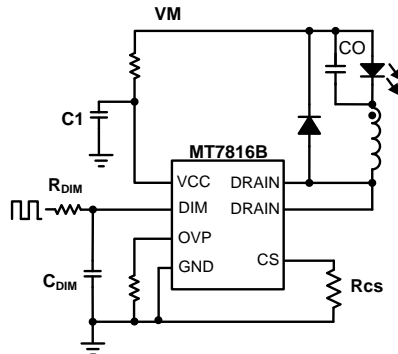

**Fig.1 Analog dimming setup**

The analog signal value after RC-filtered:

$$V_{DIM} = D_{PWM} \times V_{AM} \quad (7)$$

Where,  $V_{AM}$  is the amplitude of the PWM signal. By adjusting the duty cycle of the PWM signal ( $D_{PWM}$ ), analog dimming is achieved.

It is recommended to set the  $R_{DIM}$  to be less than 10K, to adjust the  $C_{DIM}$  to achieve PWM filtering. The ratio between the dimming frequency of PWM signal and the cutoff frequency of the  $R_{DIM} \times C_{DIM}$  should be greater than 300. Refer to Fig.1.

$$\left( \frac{F_{PWM}}{1}{2\pi \times R_{DIM} \times C_{DIM}} \right) > 300 \quad (8)$$

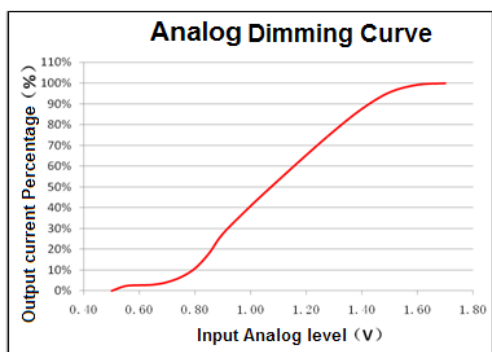
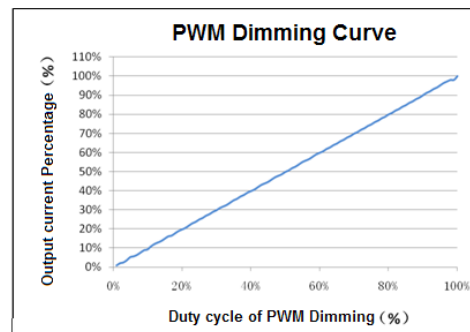

**Fig.2 Analog dimming curve**

### PWM Dimming

The output current can be adjusted by the DIM pin which connects a PWM signal. By adjusting the duty cycle of the PWM signal ( $D_{PWM}$ ) to adjust the output current to be lower than the setting value, which is set by resistor  $R_{cs}$ .

Amplitude of the PWM signal must be higher than 2.5V, and the frequency should keep in 100Hz ~ 3kHz range. The PWM dimming frequency can be increased by increasing the system operating frequency accordingly.



**Fig.3 PWM dimming curve (Dimming frequency is 1kHz)**

### Shut Down Mode

If the voltage of the DIM pin is lower than 0.5V, the system will shut down. The quiescent current of the system will keep as low as 220uA.

### LED Over Voltage Protection Setup

The OVP function is enabled by DIM pin: When  $V_{DIM} \geq 2.5V$ , OVP function is enabled; When  $V_{DIM} < 2.5V$ , OVP function is disabled.

The OVP threshold of MT7816B is adjustable through the resistor  $R_{SET}$  (Refer to Fig.4.).

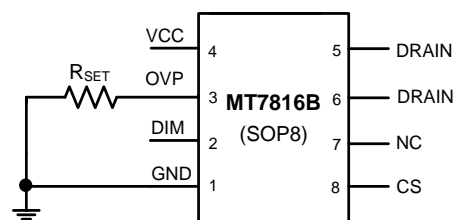

**Fig.4 OVP setup**

The OVP threshold can be calculated as:

$$V_{OVP} = \frac{2.75 \times L \times R_{SET}}{R_{CS}} \text{ (V)} \quad (9)$$

Where, L is in Henry; R<sub>CS</sub> is in ohm; R<sub>SET</sub> is in ohm

#### **Consideration for OVP Setup:**

- 1) Considering the accuracy of the inductor, the calculated value of OVP threshold by Equation above may not exactly match the real value. It is highly recommended to set the OVP threshold to be 1.3 times of the maximum LED voltage. Otherwise it may false trigger the OVP protection during normal operation, resulting in flickering.
- 2) The OVP pin can be floated. If this pin is left floating, the OVP function will be not available.
- 3) If the voltage of the inductor is relatively small, the system will enter MAXON status. Thus, the real I<sub>LPK</sub> will be lower than the calculated value, and the demagnetization time will be reduced, when the demagnetization time decreased to lower than the OVP setting value, the system will trigger OVP protection. This can be avoided through increasing the input capacitor or increasing the OVP threshold.

#### **LED Short-circuit Protection**

When the LED is shorted, the system enters MAXOFF status, and the power dissipation is reduced to be the lowest. Once the short-circuit condition is removed, MT7816B automatically resumes to normal working status.

#### **Over-current Protection**

MT7816B immediately turns off the internal switch once the voltage at CS pin reaches 400mV. This cycle- by- cycle current limitation scheme prevents the relevant components, such as external power MOSFET, transformer, etc. suffers from damage.

#### **Thermal Regulation**

The MT7816B integrates thermal regulation function to monitor the IC junction temperature. When the system is over heated, the output current is gradually reduced and so as the output power and thermal dissipation. This way the system temperature is adjusted in the reliable range. The thermal regulation temperature is 155°C.

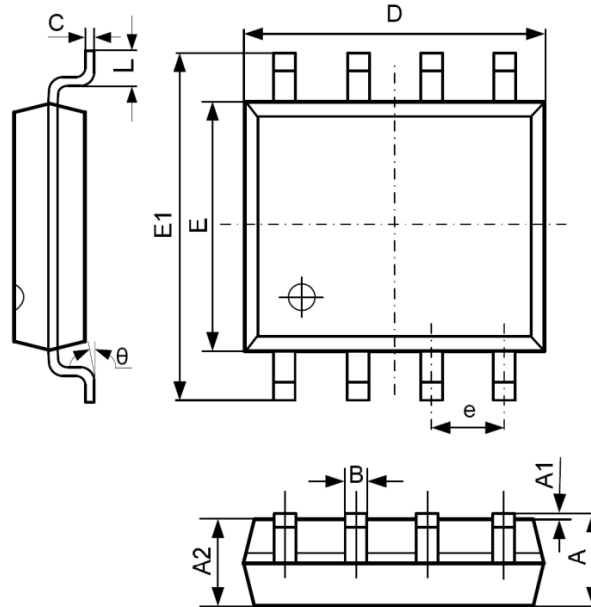
**PACKAGE INFORMATION**
**SOP8 PACKAGE OUTLINE AND DIMENSIONS**

SYMBOL	DIMENSION IN MILLIMETERS		DIMENSION IN INCHES	
	MIN	MAX	MIN	MAX
A	1.350	1.750	0.053	0.069
A1	0.100	0.250	0.004	0.010
A2	1.350	1.550	0.053	0.061
B	0.330	0.510	0.013	0.020
C	0.190	0.250	0.007	0.010
D	4.700	5.100	0.185	0.201
E	3.800	4.000	0.150	0.157
E1	5.800	6.300	0.228	0.248
e	1.270 TYP		0.050 TYP	
L	0.400	1.270	0.016	0.050
θ	0°	8°	0°	8°

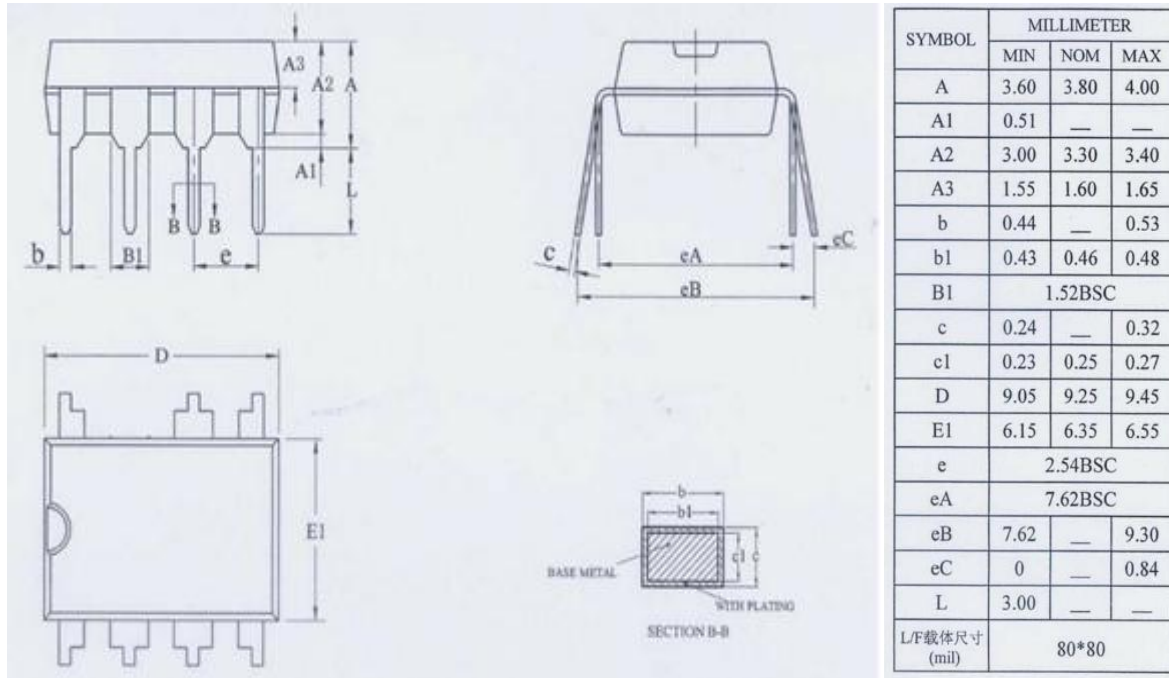

**DIP7 PACKAGE OUTLINE AND DIMENSIONS**

**Important Notice**

- Maxic Technology Corporation (Maxic) reserve the right to make correction, modifications, enhancements, improvements and other changes to its products and services at any time and to discontinue any product or service without notice. Customers should obtain the latest relevant information before placing orders and should verify that such information is current and complete. All products are sold subject to Maxic's terms and conditions of sale supplied at the time of order acknowledgement.
- Reproduction, copying, transferring, reprinting this paper without Maxic's written permission is prohibited.
- Maxic is not responsible or liable for customer product design by using Maxic components. To minimize the risks and associated with customer products and applications, customers should provide adequate design and operating safeguards and consult Maxic's sales department.