



# MT7823

## High Efficiency Buck Constant Current LED Driver

### DESCRIPTION

MT7823 is a high precision LED constant current control chip operating at critical conduction mode (CRM) with zero current switched-on and peak current switched-off. It's mainly targeted for non-isolated buck LED power systems.

Critical conduction mode ensures that the MT7823 turns on the internal power MOSFET when the inductor current reaches zero, reducing the power MOSFET switching loss, and achieving more than 95% efficiency. With critical conduction mode, MT7823 outputs high accuracy LED current, and further achieves excellent line regulation and load regulation. It's insensitive to inductance and the I-shape inductor can be used.

MT7823 is intended for simplified peripheral circuits, low BOM cost application with an internal power MOSFET.

MT7823 has wide working voltage range, which is suitable for full-range AC input or 60V-400V DC input voltage. MT7823 provides various protection features to enhance the system reliability, including over current protection (OCP), short circuit protection (SCP), and thermal adjustment, etc.

### FEATURES

- Critical Conduction Mode, insensitive to the inductance.
- High efficiency (up to 95%)
- Highly accurate constant LED current
- Cycle-by-cycle current limitation
- LED Short Circuit Protection
- Leading edge blanking technique
- Under-voltage lockout (UVLO) protection
- Thermal adjustment
- Available in SOT23-3 package

### APPLICATIONS

- LED bulb, LED tube, LED signal and landscape lamp
- LED stage light, LED candle light, LED corn light, etc.
- General purpose constant current source

### Typical Application Circuit

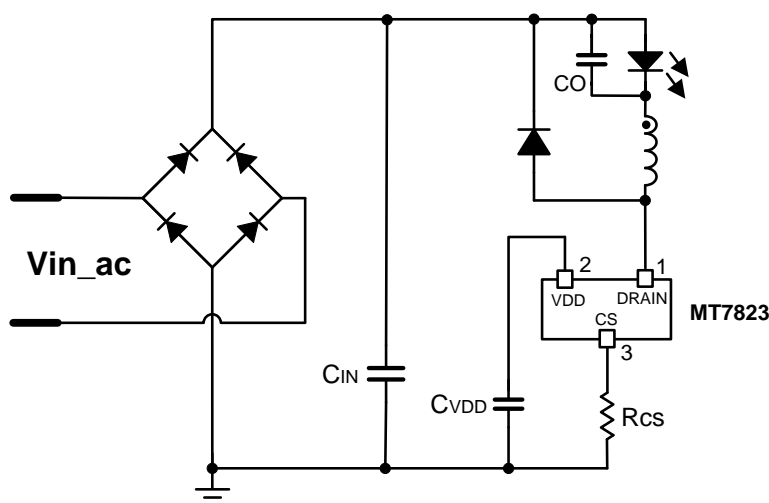



# MT7823

## High Efficiency Buck Constant Current LED Driver

### ABSOLUTE MAXIMUM RATINGS

DRAIN (internal high-voltage power MOS drain voltage)	-0.3V ~ 500V
VDD (Internal power supply output voltage)	-0.3 ~ 10V
P <sub>DMAX</sub> (maximum power consumption)	0.5W
Storage Temperature range	-55°C ~ 150°C
Junction Temperature (T <sub>j</sub> )	150°C

### RECOMMENDEDE OPERATING CONDITIONS

Operating Temperature	-40°C ~ 105°C
Output Current	<80mA (Type A )
Input voltage: 176Vac~265Vac	<130mA (Type B)
Output voltage: VLED = 36V	<180mA (Type C)

### ORDERING INFORMATIONS

Device	R <sub>DS(ON)</sub>	Mark
MT7823A	30ohm	7823AYW
MT7823B	18ohm	7823BYW
MT7823C	12ohm	7823CYW

### PIN CONFIGURATIONS

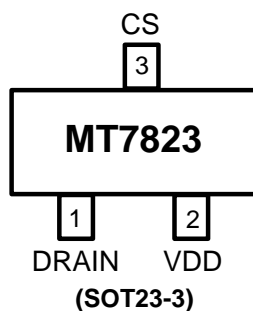

#### Chip Mark

7823XYW

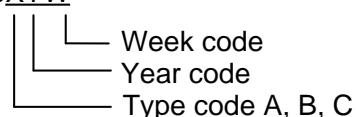

### PIN DESCRIPTION

Name	Pin No.	Description
DRAIN	1	Drain of internal high-voltage power MOSFET
VDD	2	Power supply pin. Internal clamped at 7.2V.
CS	3	Chip Ground and current sense pin, connect a sense resistor to ground

**MT7823****High Efficiency Buck Constant Current LED Driver****ELECTRICAL CHARACTERISTICS**

(Test condition: VDD=7.2V, TA=25°C unless otherwise stated.)

Symbol	Parameter		Min	Typ	Max	Unit
<b>Start-up and supply voltage (VDD Pin)</b>						
I <sub>START</sub>	VDD start up current	V <sub>DD</sub> =7V		1.0	1.8	mA
VDD	Operating voltage	normal operation		7.2		V
V <sub>DD_UV</sub>	Under voltage lockout threshold Voltage	V <sub>DD</sub> Pin ramp down		5.8		V
<b>Supply current</b>						
I <sub>op</sub>	Operating current			150		uA
<b>Current sense (CS Pin)</b>						
V <sub>REF</sub>	Peak current detection threshold		582	600	618	mV
LEB	Leading edge blanking time at CS pin			500		nS
<b>Thermal Adjustment</b>						
Tfold	Thermal adjustment temperature			150		°C
	Slope of output current decrease after the temperature exceeding the threshold Tfold			4		%/°C
<b>Driver Circuit</b>						
T <sub>OFF_MIN</sub>	Minimum OFF time			1.2		uS
T <sub>OFF_MAX</sub>	Maximum OFF time			420		uS
T <sub>ON_MAX</sub>	Maximum ON time			45		uS
<b>High-voltage Power MOSFET (DRAIN)</b>						
R <sub>DSON</sub>	MT7823A	Static drain-source on-resistance	I <sub>DS</sub> =50mA		30	Ω
R <sub>DSON</sub>	MT7823B	Static drain-source on-resistance	I <sub>DS</sub> =100mA		18	Ω
R <sub>DSON</sub>	MT7823C	Static drain-source on-resistance	I <sub>DS</sub> =150mA		12	Ω
BV <sub>DSS</sub>		Drain-source breakdown voltage	V <sub>GS</sub> =0V/I <sub>DS</sub> =250uA	500		V



**BLOCK DIAGRAM**

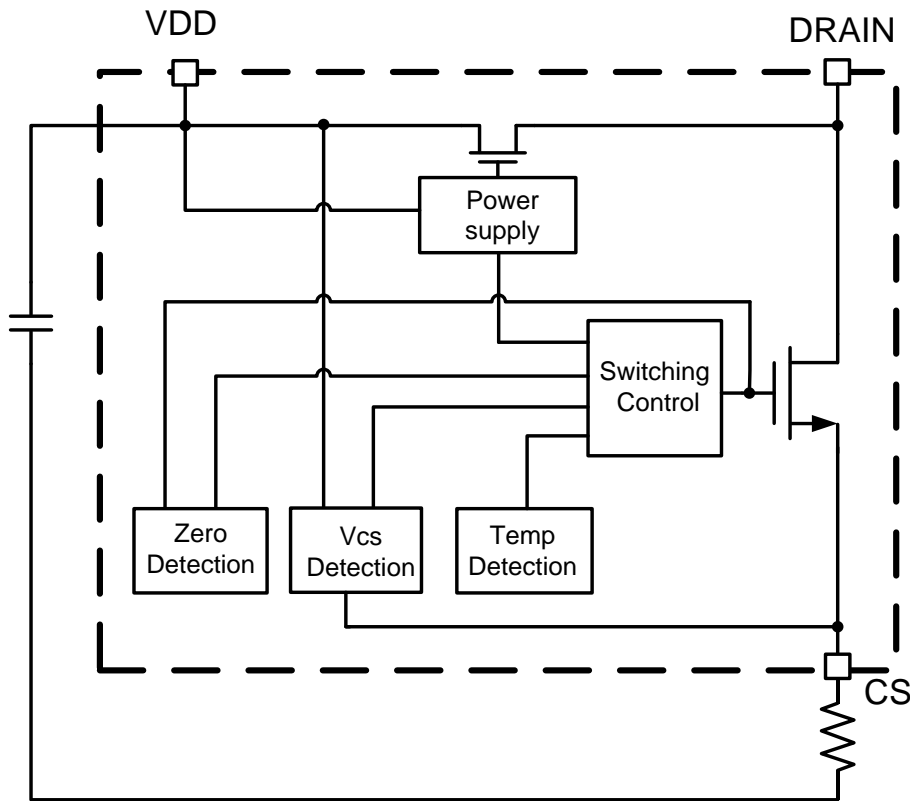

**APPLICATION INFORMATION**

MT7823 is a constant current driver with high -voltage power MOSFET. It works under critical conduction mode, and switches on the power MOSFET at zero inductor current, which improves efficiency and reduces the power MOSFET switching loss. MT7823 is specially designed for LED lighting applications, simplified peripheral circuits and low BOM cost is achieved.

**Start up**

VDD is charged by the internal JFET once the system is powered on. As the VDD reaches 7.2V, the control logic starts to work, the internal switch starts toggling, and the VDD is stabilized. MT7823 will be shut down as the VDD falls to below 5.8V.

**CRM and Output Current Setup**

The peak current of internal power MOSFET is cycle-by-cycle detected by monitoring the CS pin voltage. When the voltage on CS pin reaches 600mV (internal reference voltage), the internal power MOSFET is turned off, it will be turned on again, when the inductor current drops to zero.

The peak inductor current is given by:

$$I_{LPK} = \frac{600}{R_{CS}} (mA) \quad (1)$$

Where,  $R_{CS}$  is the current sense resistor in ohm. The CS comparator also includes a 500nS leading edge blanking time to block the transient noise as the power switch just turned on.

The LED current can be calculated as:



## MT7823

### High Efficiency Buck Constant Current LED Driver

$$I_{LED} = \frac{I_{LPK}}{2} = \frac{600mV}{2 \times R_{CS}} (mA) \quad (2)$$

Where,  $I_{LPK}$  is the peak current of the inductor. Shown in the above equation, the output current is determined by the  $R_{CS}$  and the  $V_{REF}$  (internal reference voltage), insensitive to the inductance.

#### Switching Frequency

MT7823 operates at critical conduction mode. When the inductor current is zero, the system turns on the internal power MOSFET, the inductor current rises up from the ground.

The on time of the power MOSFET is:

$$T_{ON} = \frac{L \times I_{LPK}}{V_{IN} - V_{LED}} \quad (3)$$

Where, L is the inductance of the inductor;  
 $I_{LPK}$  is the peak current through the inductor;  
 $V_{IN}$  is the DC voltage of the rectified input voltage;  
 $V_{LED}$  is the forward voltage dropped on the LED.  
 When the CS voltage increases to  $V_{REF}$ , the internal power MOSFET is switched off. The inductor current will discharge the LED through the free-wheeling diode. The internal power MOSFET won't be turned on until the current in the inductor drops to zero. The off time of the power MOSFET is:

$$T_{OFF} = \frac{L \times I_{LPK}}{V_{LED}} \quad (4)$$

Operating frequency of the system is:

$$f = \frac{1}{T_{ON} + T_{OFF}} = \frac{V_{LED} \times (1 - \frac{V_{LED}}{V_{IN}})}{L \times I_{LPK}} \quad (5)$$

From the above equation, it's showing that MT7823 operating frequency is determined by the input voltage  $V_{IN}$ , the LED forward voltage  $V_{LED}$  and the inductance L. The higher input voltage  $V_{IN}$  makes operating frequency higher. For both EMI and efficiency consideration, the operating frequency located between

30kHz~80kHz is recommended. To meet this requirement, appropriate inductance value should be determined at minimum input voltage condition.

MT7823 sets the maximum off-time  $T_{OFF\_MAX}=420\mu S$ , the minimum off-time  $T_{OFF\_MIN}=1.2\mu S$ . Shown in  $T_{OFF}$  equation, if the inductance is large,  $T_{OFF}$  maybe longer than  $T_{OFF\_MAX}$ , the system will turn on the switch before the inductor current falls to zero. On the contrary, if inductance is small,  $T_{OFF}$  may be shorter than  $T_{OFF\_MIN}$ , then the inductor current has already been reduced to zero before the next cycle starts, the system enters into discontinuous mode. The actual LED current will be smaller than the target value. It's important to choose the proper inductance and operating frequency.

#### Over-current Protection

MT7823 immediately turns off the internal power MOSFET once the voltage on CS pin reaches 600mV. This cycle-by-cycle current limitation scheme prevents the relevant components, such as power MOSFET, transformer, etc. suffers from damage.

#### Other Protection Features

MT7823 provides various protections, such as LED short-circuit protection, over temperature protection, etc.

When the LED short-circuit is detected, MT7823 immediately enters short-circuit protection status, the system works at MAXOFF status. So the system power consumption is very low. Once the short-circuit condition is removed, the system automatically resumes to normal working status. The MT7823 integrates a thermal protection function to monitors the IC junction temperature. When the IC junction temperature exceeds  $T_{fold}$ , the LED output current is gradually reduced. Thus, the output power and thermal dissipation



are also reduced. In this way, the system temperature is limited and system reliability is also enhanced.

### **PCB Layout Consideration**

- 1) The VDD (Pin2) de-coupling capacitor (typically 1uF ~ 4.7uF ceramic capacitor) must close to the pin (Pin2) as much as possible. Better not exceed 5mm. This can greatly improve the system noise immunity.
- 2) Increase the copper area of each pin for better thermal dissipation (refer to Fig.1).

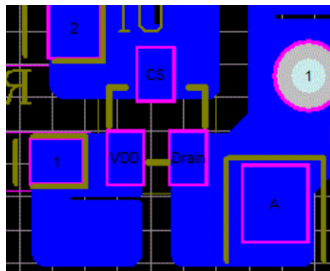

**Fig. 1 Copper area**



**MT7823**

**High Efficiency Buck Constant Current LED Driver**

**PACKAGE INFORMATION**

**SOT23-3 PACKAGE OUTLINE AND DIMENSIONS**

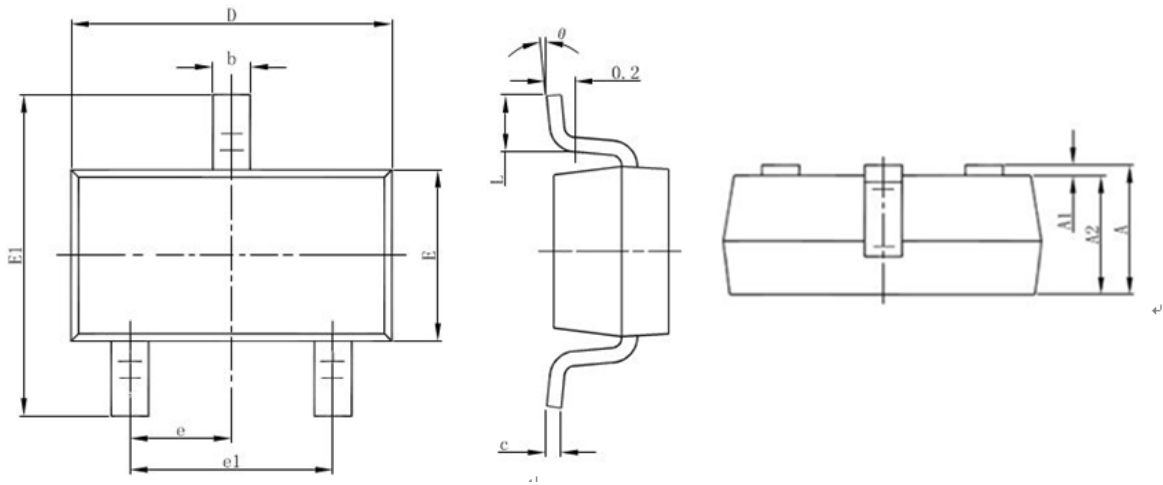

Symbol	Dimensions In Millimeters		Dimensions In Inches	
	Min	Max	Min	Max
A	1.050	1.250	0.041	0.049
A1	0.000	0.100	0.000	0.004
A2	1.050	1.150	0.041	0.045
b	0.300	0.500	0.012	0.020
c	0.100	0.200	0.004	0.008
D	2.820	3.020	0.111	0.119
E	1.500	1.700	0.059	0.067
E1	2.650	2.950	0.104	0.116
e	0.950(BSC)		0.037(BSC)	
e1	1.800	2.000	0.071	0.079
L	0.300	0.600	0.012	0.024
θ	0°	8°	0°	8°

**Important Notice**

- Maxic Technology Corporation (Maxic) reserve the right to make correction, modifications, enhancements, improvements and other changes to its products and services at any time and to discontinue any product or service without notice. Customers should obtain the latest relevant information before placing orders and should verify that such information is current and complete. All products are sold subject to Maxic’s terms and conditions of sale supplied at the time of order acknowledgement.
- Reproduction, copying, transferring, reprinting this paper without Maxic’s written permission is prohibited.
- Maxic is not responsible or liable for customer product design by using Maxic components. To minimize the risks and associated with customer products and applications, customers should provide adequate design and operating safeguards and consult Maxic’s sales department.