



MT7834A

Maximizing IC Performance

Non-isolated APFC BUCK LED Driver

DESCRIPTION

The MT7834A is a high-PF, non-isolate LED Driver IC. The floating-ground, high-side BUCK topology makes full wave detection possible. The MT7834A works in Quasi-Resonant mode (QRM), which improves both of efficiency and EMI performance. Selectable maximum period control is integrated, such that flick can be eliminated while enough demagnetization time is guaranteed.

Various protections such as OVP, OCP, OTP, etc, are embedded to improve reliability. The MT7834A integrate 550V MOSFET internally, which simplifies external circuit.

The driving capability of the MT7834A is designed to be insensitive to VDD voltage and soft, with MAXIC proprietary technique. It can help to improve EMI performance greatly.

FEATURES

- Single-stage active power factor correction (PFC > 0.90)
- High accurate LED current (+/-3%)
- Good Line and Load Regulation (+/-2%)
- Quasi-Resonant mode (QRM) operation
- Various protection schemes.
- Power-on soft-start
- Support powered by single-winding inductor
- Compact package: SOP8

APPLICATIONS

- E27/PAR30/PAR38/GU10 LED lamp
- T8/T10 LED tube
- Other LED lighting applications

Typical Application Circuit

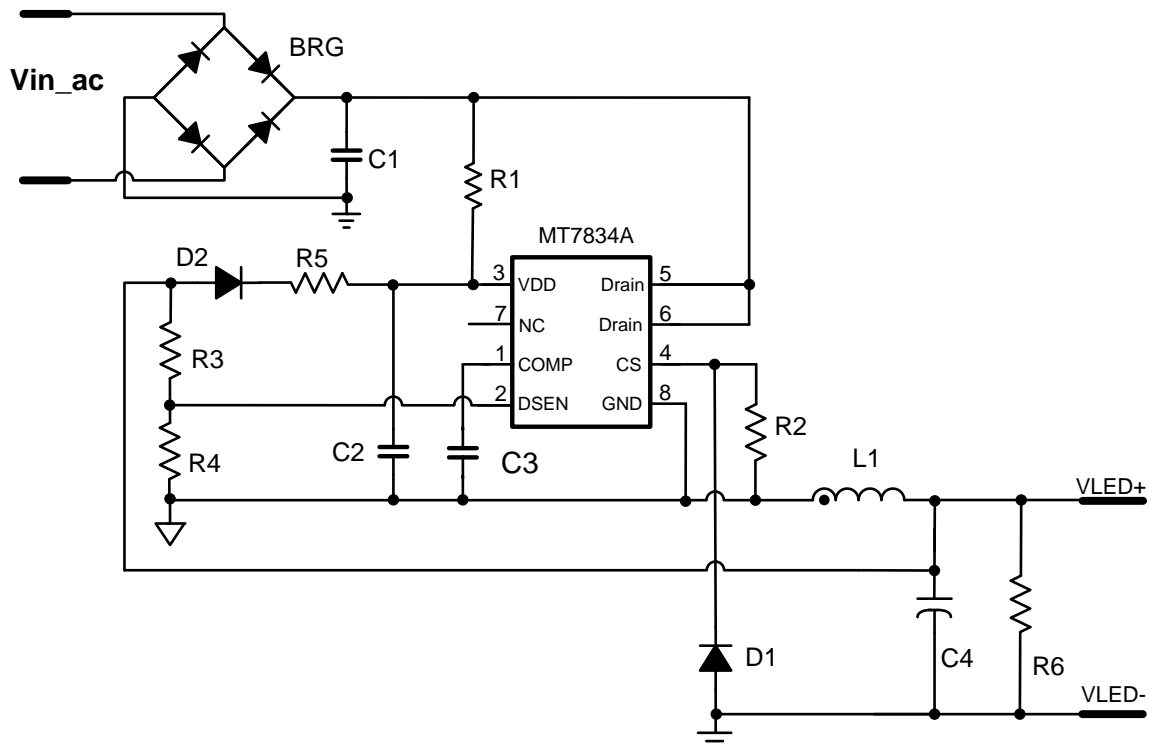



MT7834A

Maximizing IC Performance

Non-isolated APFC BUCK LED Driver

ABSOLUTE MAXIMUM RATINGS

VDD Pin Voltage	-0.3V to VDD Clamp
Drain Pin Voltage	-0.3V to 550V
COMP/CS/DSEN Pins Voltage	-0.3V to 6V
Lead Temperature (soldering, 10 sec.)	260°C
P _{DMAX} (maximum power consumption)	0.8W(SOP8);
Storage Temperature	-55°C to 150°C

Recommended operating conditions

Supply voltage	9V to 24V
Operating Temperature (Environment)	-40°C to 105°C
Output Power	≤ 18W @ 90VAC~264VAC ≤ 24W @ 176VAC~264VAC

Thermal resistance^①

Junction to ambient (R _{θJA})	128°C/W
---	---------

Note:

① R_{θJA} is measured in the natural convection at TA = 25°C on a low effective single layer thermal conductivity test board of JEDEC 51-3 thermal measurement standard. Test condition: Device mounted on 2" X 2" FR-4 substrate PCB, 2oz copper, with minimum recommended pad on top layer and thermal vias to bottom layer ground plane.

PIN CONFIGURATIONS

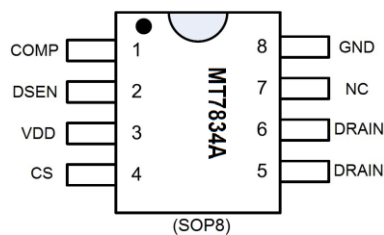

Chip Mark

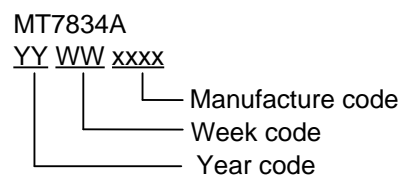

PIN DESCRIPTION

Name	Pin No.	Description
COMP	1	Internal EA's output pin. Connect a capacitor to ground for frequency compensation.
DSEN	2	Feedback pin for inductor zero current crossing detection.
VDD	3	Power Supply pin.
CS	4	Source of internal MOSFET, and Current Sense pin.
DRAIN	5,6	Drain of internal MOSFET.
NC	7	No connection pin.
GND	8	Ground pin.

**MT7834A****Maximizing IC Performance****Non-isolated APFC BUCK LED Driver****ELECTRICAL CHARACTERISTICS**(Test conditions: $V_{DD}=15V$, $T_A=25^{\circ}C$ unless otherwise stated.)

Symbol	Parameter	Conditions	Min	Typ	Max	Unit
Start-up (VDD Pin)						
V_{STP}	Start-up Voltage	VDD Ramp-up from 0V		18		V
UVLO	Under Voltage Lockout	VDD Ramp-down from ($V_{STP}+1V$)		9		V
I_{STP}	Start-up Current	VDD=16V		25		μA
V_{DD_CLAMP}	VDD clamp voltage			24		V
I_{CLAMP}	Sinking Current Capability to Clamp VDD			10		mA
Power Supply Current						
I_Q	Quiescent Current			1.0		mA
Control Loop (DSEN Pin)						
V_{REF-FB}	Voltage Reference for Feedback Loop	Close the Feedback Loop	196	200	204	mV
SCP	Threshold of Short Circuit Protection at DSEN Pin			400		mV
OVP	Over Voltage Protection of DSEN Pin			3.2		V
LEB1	Leading Edge Blank for DSEN Pin			2		μS
MinT	Minimum Switching Period			10		μS
Current Sense Pin (CS Pin)						
OCP	Threshold of Over Current Protection at CS Pin			1.4		V
LEB2	Leading Edge Blank for CS Pin			300		nS
Thermal Protection						
OTP	Over Temperature Protection			155		$^{\circ}C$
Hys_OTP	Hysteresis of OTP			15		$^{\circ}C$
Internal MOSFET (DRAIN Pin)						
R_{on}	Internal MOSFET turn-on resistance	$V_{GS}=10V/I_{DS}=1.5A$		2		Ω
BV_{DSS}	Breakdown voltage	$V_{GS}=0V/I_{DS}=250\mu A$	550			V



MT7834A

Maximizing IC Performance

Non-isolated APFC BUCK LED Driver

BLOCK DIAGRAM

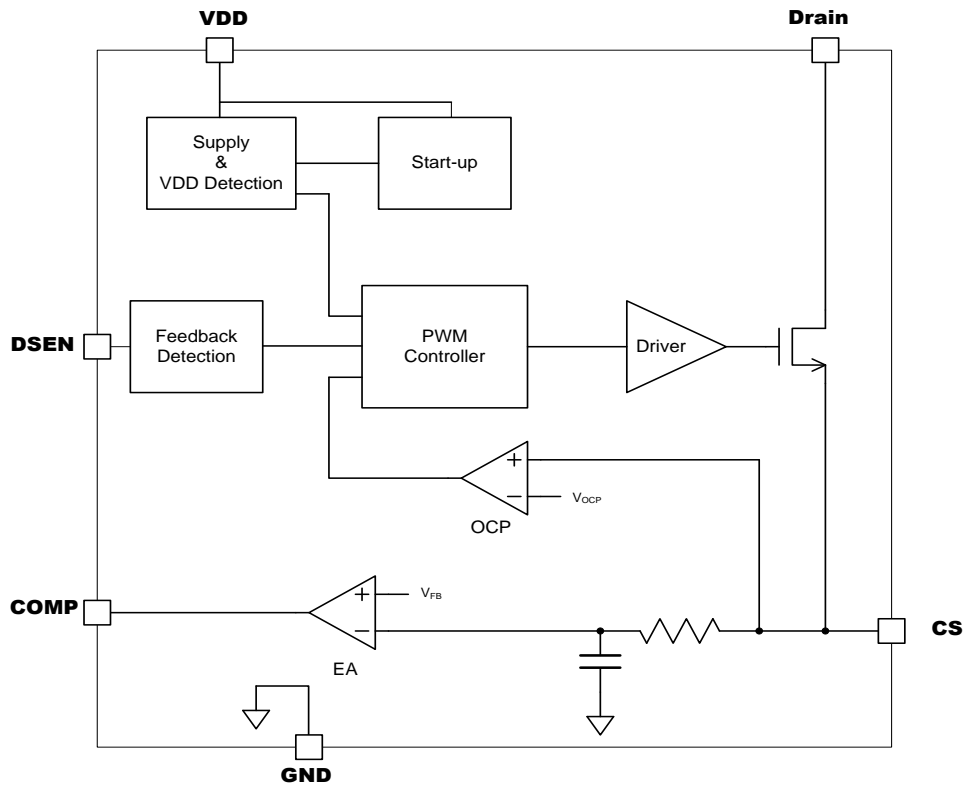

APPLICATION INFORMATION

The MT7834A integrates power factor correction function and works in Quasi-Resonant Mode (QRM). The LED current can be accurately regulated through sensing the inductor current signal.

Averaged Current Control

The MT7834A accurately regulates LED current through sensing the inductor current signal. The LED current can be easily set by:

$$I_{LED} = \frac{V_{FB}}{R_S}$$

Where V_{FB} ($\approx 200mV$) is the internal reference voltage and R_S is an external current sensing resistor (R_S is the R_2 in circuit in page1).

Start Up

During start-up, the capacitor at VDD is charged through the resistor which is connected to input voltage. The internal control logic starts to work when VDD reaches 18V. The COMP pin is, therefore, pre-charged during this process. The internal control loop is established. Once the voltage of COMP reaches 1.4V, the whole system works in normal operation mode.

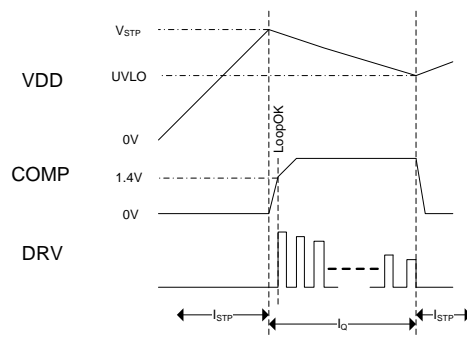

Fig.1 Start up sequence



MT7834A

Maximizing IC Performance

As the VDD goes below 9V, the system is considered to be UVLO, the PWM signal of DRV goes low, and the voltage of COMP is discharged to 0V. The detailed start-up sequence is shown in Fig. 1.

Auxiliary Sensing

The voltage waveform of the inductor is sensed during PWM OFF period for switching logic control, over-voltage protection (OVP), short-circuit protection (SCP), etc.

The DSEN senses the inductor voltage through a resistor divider. The sampling strobe window is 2us LEB (Leading Edge Blanking) time right after the DRV signal is low for better noise immunity as shown in Fig. 2.

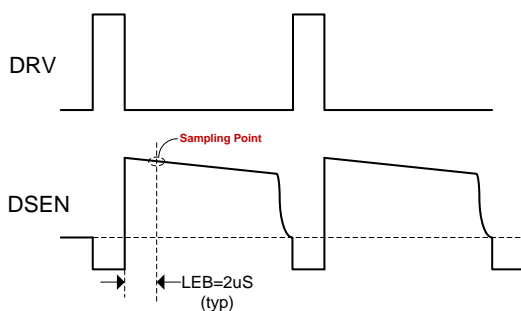

Fig.2 Auxiliary Signal Sensing

Hiccup Mode

Any detected fault conditions, such as, over-voltage (OV), short-circuit (SC) conditions, will force MT7834A into hiccup mode, and PWM signal goes low. VDD is therefore discharged by the MT7834A itself. Then VDD continues to drop below UVLO threshold. A start-up sequence is initiated. If the fault conditions are removed, the LED driver goes back to normal.

The hiccup mode keeps the system at low power dissipation state during fault conditions, enhancing system reliability.

Over-voltage Protection

The MT7834A integrates Over Voltage Protection function. if the DSEN voltage exceeds

Non-isolated APFC BUCK LED Driver

3.2V three times in 1mS during PWM OFF period(Refer to “Auxiliary Sensing”), the MT7834A gets in Hiccup mode to protect the system and lower the power consumption. The threshold of Over Voltage Protection for LED can be set as following (refer to the application circuit in page 1):

$$V_{OUT_OV} = 3.2 * \left(1 + \frac{R3}{R4}\right)$$

If VDD is powered by auxiliary winding (refer to Fig 3.), the threshold of Over Voltage Protection for LED can be set as following:

$$V_{OUT_OV} = 3.2 * \left(1 + \frac{R3}{R4}\right) * \frac{N_p}{N_a}$$

Where Np is the turns of primary winding, Na is the turns of auxiliary winding.

It's highly recommended to keep DSEN pin voltage below 2.7V during normal working condition by chosen proper R3 to R4 ratio.

Short-circuit Protection

The short-circuit protection is triggered if the DSEN voltage is detected below 400mV during OFF period for a continuous time of 5 to 10ms. The MT7834A gets into hiccup mode.

Over-current Protection

The MT7834A immediately turns off the power MOSFET once the voltage at CS pin exceeds 1.4V. This cycle by cycle current limitation scheme prevents the relevant components, such as power MOSFET, inductor, etc. from damage.

Powered by Transformer auxiliary winding

MT7834A can also powered by transformer auxiliary winding to further reduce the system power dissipation. Refer to Fig.3. VDD voltage and DSEN feedback detection can be more accurate by this way.



MT7834A

Maximizing IC Performance

Non-isolated APFC BUCK LED Driver

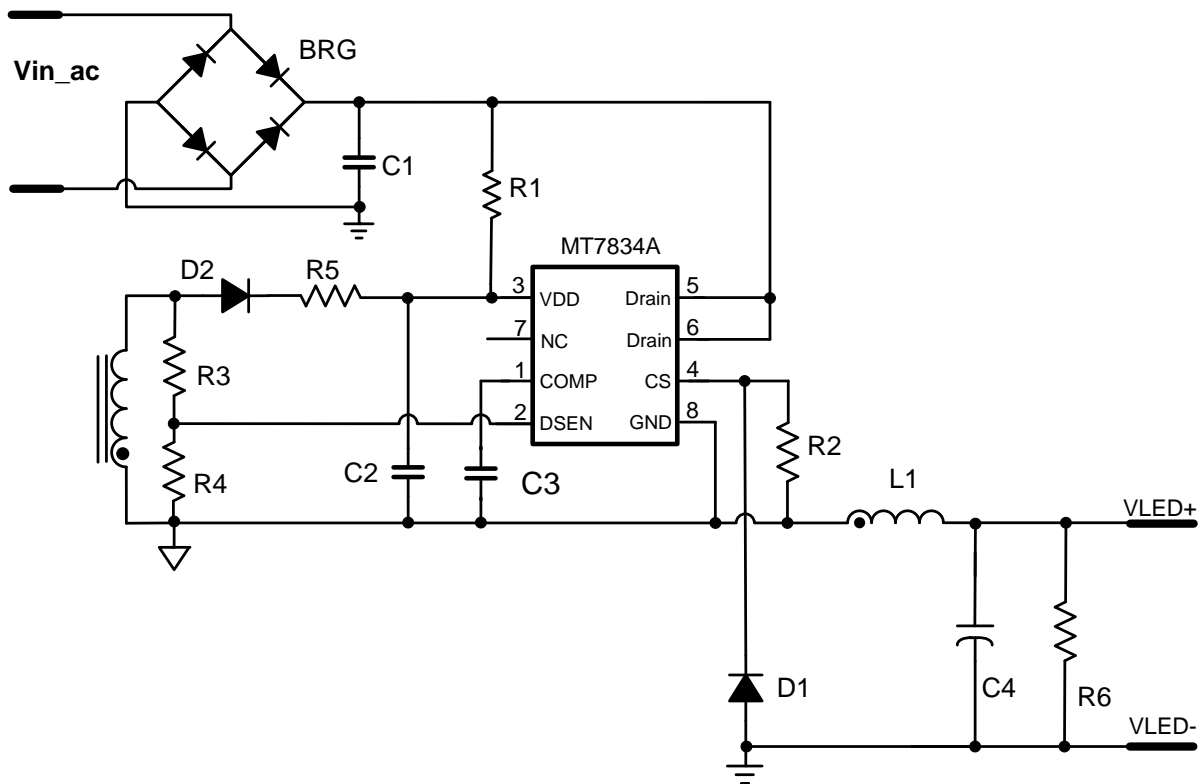

Fig.3 Transformer auxiliary winding to power the VDD



MT7834A

Maximizing IC Performance

Non-isolated APFC BUCK LED Driver

PACKAGE INFORMATION

SOP-8 PACKAGE OUTLINE AND DIMENSIONS

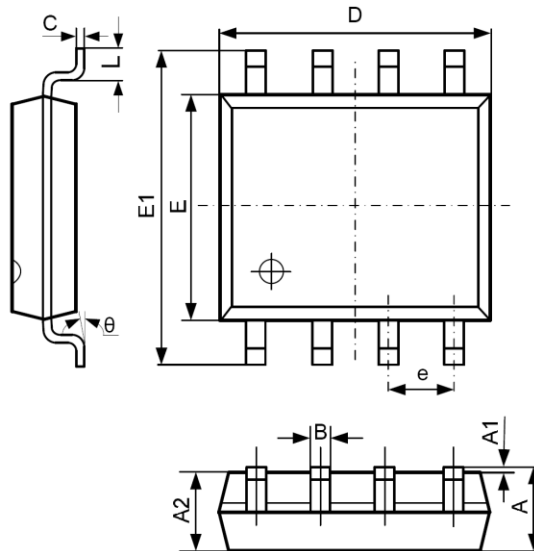

SYMBOL	DIMENSION IN MILLIMETERS		DIMENSION IN INCHES	
	MIN	MAX	MIN	MAX
A	1.350	1.750	0.053	0.069
A1	0.100	0.250	0.004	0.010
A2	1.350	1.550	0.053	0.061
B	0.330	0.510	0.013	0.020
C	0.190	0.250	0.007	0.010
D	4.700	5.100	0.185	0.201
E	3.800	4.000	0.150	0.157
E1	5.800	6.300	0.228	0.248
e	1.270 TYP		0.050 TYP	
L	0.400	1.270	0.016	0.050
theta	0°	8°	0°	8°

Important Notice

- Maxic Technology Corporation (Maxic) reserve the right to make correction, modifications, enhancements, improvements and other changes to its products and services at any time and to discontinue any product or service without notice. Customers should obtain the latest relevant information before placing orders and should verify that such information is current and complete. All products are sold subject to Maxic's terms and conditions of sale supplied at the time of order acknowledgement.
- Reproduction, copying, transferring, reprinting this paper without Maxic's written permission is prohibited.
- Maxic is not responsible or liable for customer product design by using Maxic components. To minimize the risks and associated with customer products and applications, customers should provide adequate design and operating safeguards and consult Maxic's sales department.