

DESCRIPTION

The MT7838 is a single-stage buck average constant current controller. With MAXIC proprietary control technique, the system with MT7838 can achieve both high current accuracy and power factor correction. MT7838 works in critical conduction mode (CRM) to reduce switching losses.

The MT7838 can be powered up directly by the main-line voltage without the need of start-up resistors, achieving an ultra fast start-up time of less than 100ms.

The MT7838 provides various protections, such as over current protection (OCP), over voltage protection (OVP), short circuit protection (SCP) and over temperature protection (OTP), etc, to maintain system reliability.

FEATURES

- Single-stage active power factor correction (PFC > 0.90)
- Ultra-fast start-up time (<100ms)
- High accurate LED current
- Critical conduction mode (CRM) operation
- Up to 60 watt driving capability.
- Various protection schemes.
- Adjustable constant current and output power setting
- Power-on soft-start
- Compact package: SOP8

APPLICATIONS

- E14/E27/PAR30/PAR38/GU10 LED lamp
- T8/T10 LED tube
- Other LED lighting applications

Typical Application Circuit

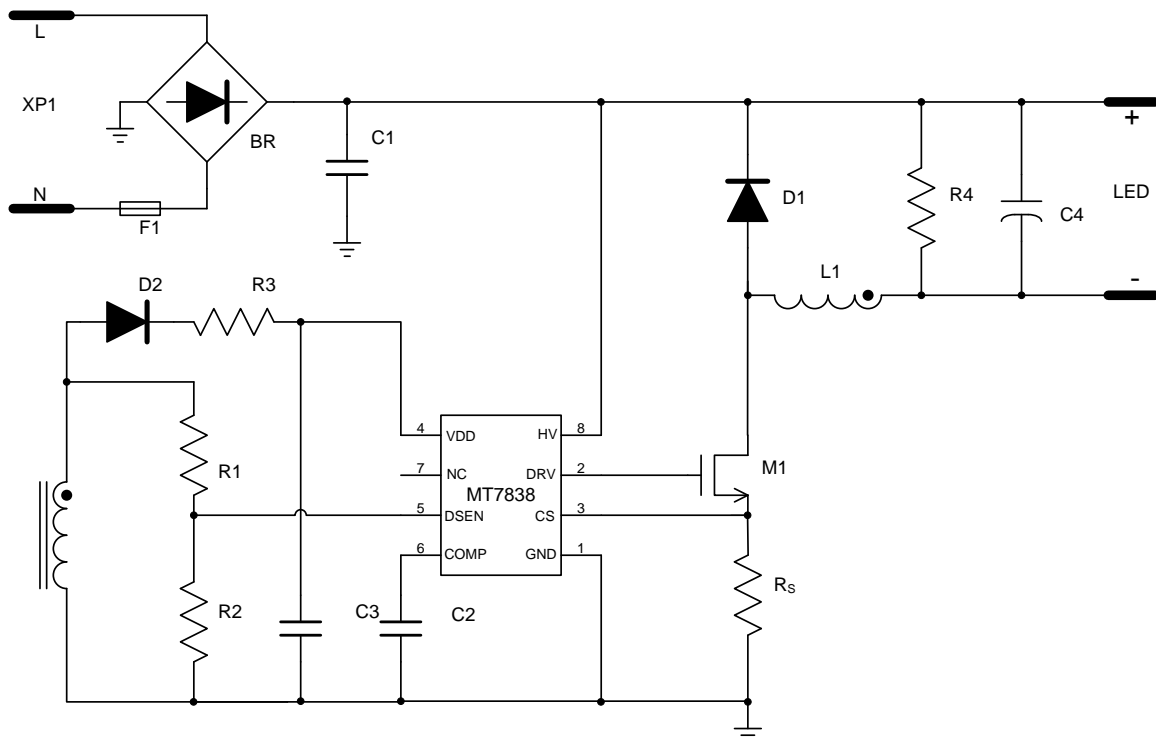

ABSOLUTE MAXIMUM RATINGS

VDD/DRV Pins Voltage	-0.3V to VDD Clamp
HV Pin Voltage	-0.3V to 700V
COMP/CS/DSEN Pins Voltage	-0.3V to 5V
Lead Temperature (soldering, 10 sec.)	260°C
Storage Temperature	-55°C to 150°C
Junction Temperature (Tj)	150°C

Recommended operating conditions

Supply voltage	7.2V to 24V
Operating Temperature	-40°C to 105°C

Thermal resistance^①

Junction to ambient (R θ JA)	128°C/W
-------------------------------------	---------

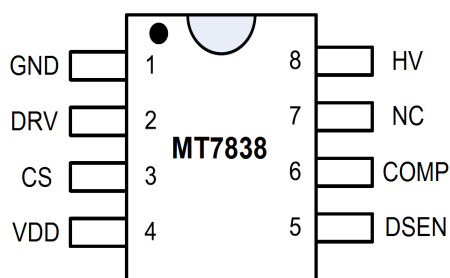
PIN CONFIGURATIONS

PIN DESCRIPTION

Name	Pin No.	Description
GND	1	Ground pin.
DRV	2	Gate drive output pin for the external MOSFET.
CS	3	Current Sense pin.
VDD	4	Power Supply pin.
DSEN	5	Feedback pin for inductor zero current crossing detection. This pin also provide over voltage protection simultaneously.
COMP	6	Internal EA's output pin. Connect a capacitor to ground for frequency compensation.
NC	7	No connection pin
HV	8	IC start-up. High-voltage pin.

ELECTRICAL CHARACTERISTICS

 (Test conditions: $V_{DD}=12V$, $T_A=25^{\circ}C$ unless otherwise stated.)

Symbol	Parameter	Conditions	Min	Typ	Max	Unit
Start-up (VDD pin)						
I_{START}	Start up Current			25	50	μA
UVLO	Lower Threshold Voltage of V_{DD}	V_{DD} ramp down		7.2		V
V_{START}	Start-up Voltage	V_{DD} ramp up		18		V
Supply Current						
I_q	Quiescent Current	No switching		1.5		mA
Control Loop (COMP, DSEN Pin)						
V_{FB}	Primary Current Sense Voltage at CS pin.		392	400	408	mV
V_{COMPH}	Upper Limit of COMP			2.0		V
SCP	Short Circuit Protection Threshold at DSEN pin			400		mV
OVP1	Over Voltage Protection Threshold at VDD pin			24		V
OVP2	Over Voltage Protection Threshold at DSEN			3.2		V
Current Sense (CS pin)						
LEB	Leading Edge Blanking of CS			200		nS
OCP	Over Current Protection at CS pin			1.2		V
Thermal Protection						
OTP	Over Temperature Protection			150		$^{\circ}C$
	Over Temperature Release Hysteresis			20		$^{\circ}C$
Drive Stage (DRV pin)						
T_R	Rising Time	$CL=1nF$, DRV falls from V_{DD} to 0V		50 ^②		nS
T_F	Falling Time	$CL=1nF$, DRV rises from 0V to V_{DD}		30 ^②		nS

Note:

① $R_{\theta JA}$ is measured in the natural convection at $T_A = 25^{\circ}C$ on a low effective single layer thermal conductivity test board of JEDEC 51-3 thermal measurement standard. Test condition: Device mounted on 2" X 2" FR-4 substrate PCB, 2oz copper, with minimum recommended pad on top layer and thermal vias to bottom layer ground plane.

② Guaranteed by design.

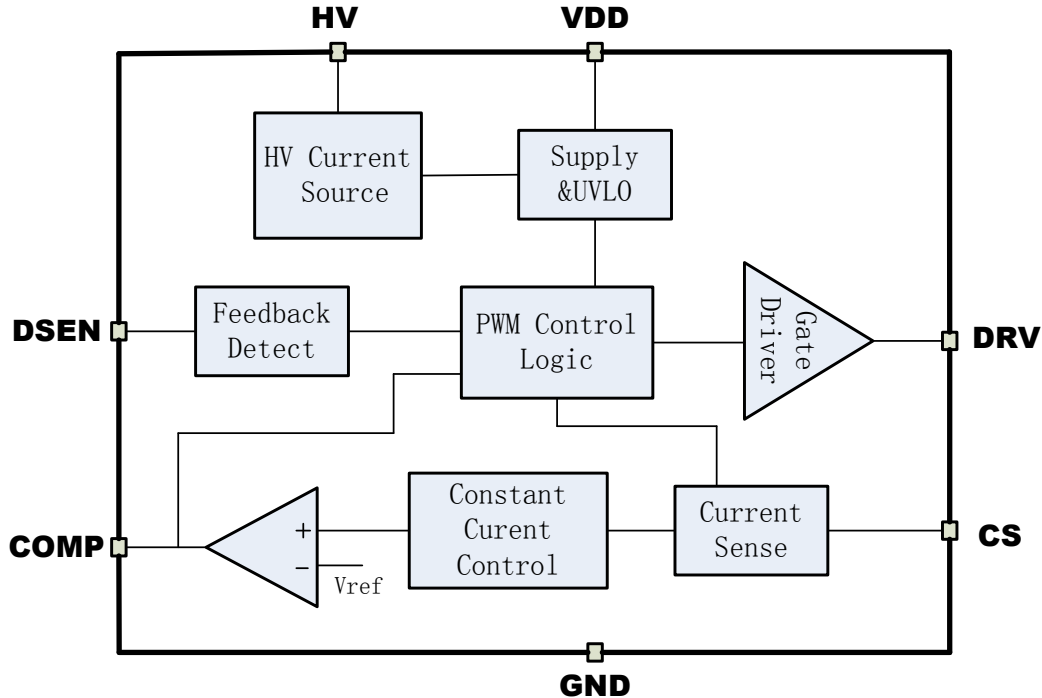
BLOCK DIAGRAM

APPLICATION INFORMATION

The MT7838 integrates power factor correction function and works in Critical Conduction Mode (CRM). The LED current can be accurately regulated through sensing the primary winding current signal.

Averaged Current Control

The MT7838 accurately regulates LED current through sensing the primary winding current signal. The LED current can be easily set by:

$$I_{LED} = \frac{1}{2} \cdot \frac{V_{FB}}{R_S}$$

Where V_{FB} (=400mV) is the internal reference voltage and R_S is an external current sensing resistor.

Start Up

During start-up, the capacitor at VDD is charged

through the high-voltage pin (HV) at an ultra fast start-up of less than 100ms. The internal control logic starts to work when VDD reaches 18V. The COMP pin is, therefore, pre-charged during this process. The internal control loop is established. Once the voltage of COMP reaches 0.8V, the whole system works in normal operation mode.

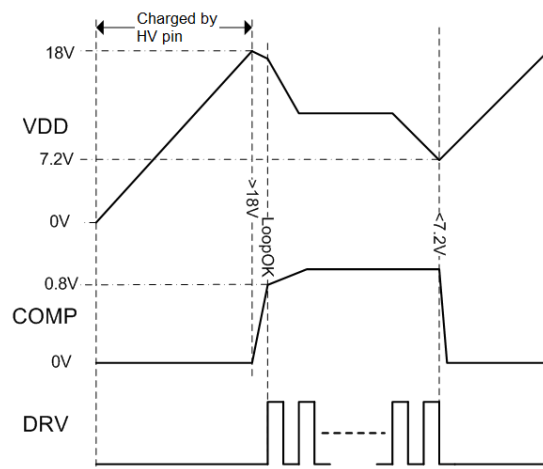

Fig.1 Start up sequence

As the VDD goes below 7.2V, the system is

considered to be UVLO, the PWM signal of DRV goes low, and the voltage of COMP is discharged to 0V. The detailed start-up sequence is shown in Fig. 1.

Auxiliary Sensing

The voltage waveform of the auxiliary winding is sensed during PWM OFF period for switching logic control and over-voltage (OVP), short-circuit protection (SCP).

The DSEN senses the auxiliary winding voltage through a resistor divider. The sampling strobe window is 2us LEB (Leading Edge Blanking) time right after the DRV signal is low for better noise immunity as shown in Fig. 2.

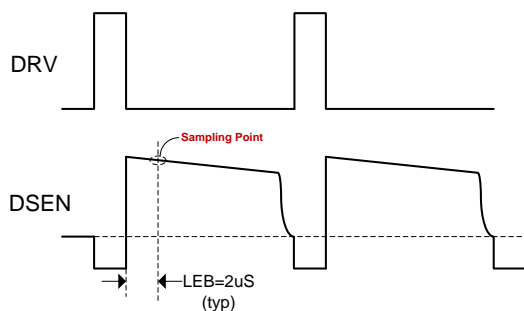

Fig.2 Auxiliary Signal Sensing

Stand-by Mode

Any detected fault conditions, such as, over-voltage (OV), short-circuit (SC) conditions, will force MT7838 into stand-by mode, and PWM signal goes low. VDD is therefore set to 9V for a fixed time of 800ms, typically. Then VDD continues to drop below UVLO threshold. A start-up sequence is initiated. If the fault conditions are removed, the LED driver goes back to normal.

The stand-by mode keeps the system at low power dissipation state during fault conditions, enhancing system reliability.

Over-voltage Protection

The MT7838 is implemented with two over-voltage protection schemes: (1) If DSEN voltage is detected above 3.2V for three times in a row (refer to **Auxiliary Sensing** section), the LED driver gets in stand-by mode. The threshold voltage of over-voltage protection V_{OUT_OV} , can be easily defined as (refer to the application circuit in page 1):

$$V_{OUT_OV} = 3.2 * \left(1 + \frac{R1}{R2}\right) * \frac{N_p}{N_a}$$

Where N_p is the primary winding, N_a is auxiliary winding; (2) If VDD exceeds 24V three times in a row, the LED driver gets in stand-by mode. It is highly recommended to set up the VDD voltage between 12V and 22V through choosing a proper N_a/N_p ratio of the transformer.

Short-circuit Protection

The short-circuit protection is triggered if the DSEN voltage is detected below 400mV during OFF period for a continuous time of 2.5 to 5ms. The MT7838 gets in stand-by mode.

Over-current Protection

The MT7838 immediately turns off the power MOSFET once the voltage at CS pin exceeds 1.2V. This cycle by cycle current limitation scheme prevents the relevant components, such as power MOSFET, transformer, etc. from damage.

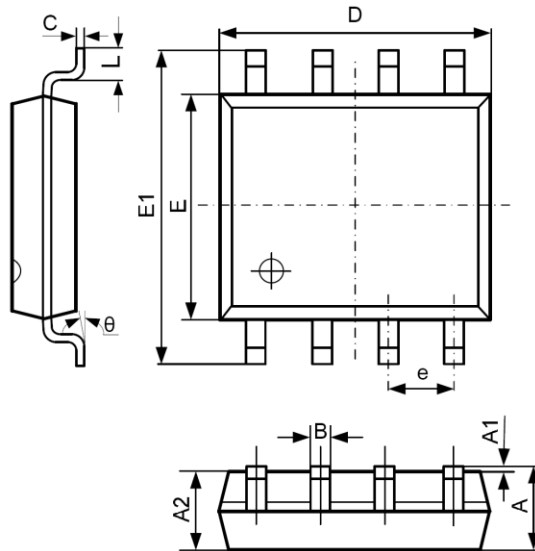
PACKAGE INFORMATION
SOP-8 PACKAGE OUTLINE AND DIMENSIONS

SYMBOL	DIMENSION IN MILLIMETERS		DIMENSION IN INCHES	
	MIN	MAX	MIN	MAX
A	1.350	1.750	0.053	0.069
A1	0.100	0.250	0.004	0.010
A2	1.350	1.550	0.053	0.061
B	0.330	0.510	0.013	0.020
C	0.190	0.250	0.007	0.010
D	4.700	5.100	0.185	0.201
E	3.800	4.000	0.150	0.157
E1	5.800	6.300	0.228	0.248
e	1.270 TYP		0.050 TYP	
L	0.400	1.270	0.016	0.050
θ	0°	8°	0°	8°



MT7838

Maximizing IC Performance

Non-Isolated, High PFC, BUCK LED Driver

For detail products information and sample requests, please contact:

Maxic Technology Corporation (Beijing Office)

1006, Crown Plaza Office Tower, No106, ZhiChun Road, Hai Dian District, Beijing, China, 100086

Tel: 86-10-62662828

Fax: 86-10-62662951

Maxic Technology Coporation (Shenzhen office)

25BC, Fortune Plaza, Futian District, Shenzhen 518040

Tel: 86-0755-83021778

Fax: 86-0755-83021336

Maxic Technology Corporation(Hong Kong office)

Rm D1, 7th floor, JianAn Commercial Building,

No. 49-51, Suhong Str., Sheung Wan, Hong Kong

Web: www.maxictech.com

E-mail: sales@maxictech.com, info@maxictech.com