



MT7955L

Maximizing IC Performance

High Accuracy, Primary-side AC-DC LED Driver

DESCRIPTION

MT7955L is a primary-side controller for AC-DC LED lighting. It operates in constant current control mode and works in discontinuous conduction mode, suitable for flyback converter under universal input.

MT7955L adopts primary side sensing and regulation technology, no secondary side feedback circuit is needed. Further, the loop compensation components are also eliminated while maintaining system stability. With building in 600V power MOSFET, low component counts and low BOM cost are achieved.

By using Maxim proprietary current regulation method, the MT7955L achieves $\pm 3\%$ accuracy of LED current along with excellent line regulation and load regulation.

MT7955L provides plenty of protections, such as LED short circuit protection, LED open circuit protection, over-temperature protection, VDD over voltage protection, VDD under voltage lock-out, etc.

FEATURES

- Build in 600V power MOSFET
- 85V to 265V AC line voltage range
- Primary side sensing and regulation, no need of secondary side feedback
- High precision constant LED current (+/-3%)
- Cycle-by-cycle peak current control
- LED short-circuit/open circuit protection
- VDD under voltage lock-out protection
- VDD over voltage protection
- Over temperature protection
- Built-in leading edge blanking (LEB)
- Extremely minimum external components
- Available in DIP8 package

APPLICATION

- E27/PAR30/PAR38/GU10 LED lamp
- LED lighting application
- General purpose constant current source

Typical Application Circuit

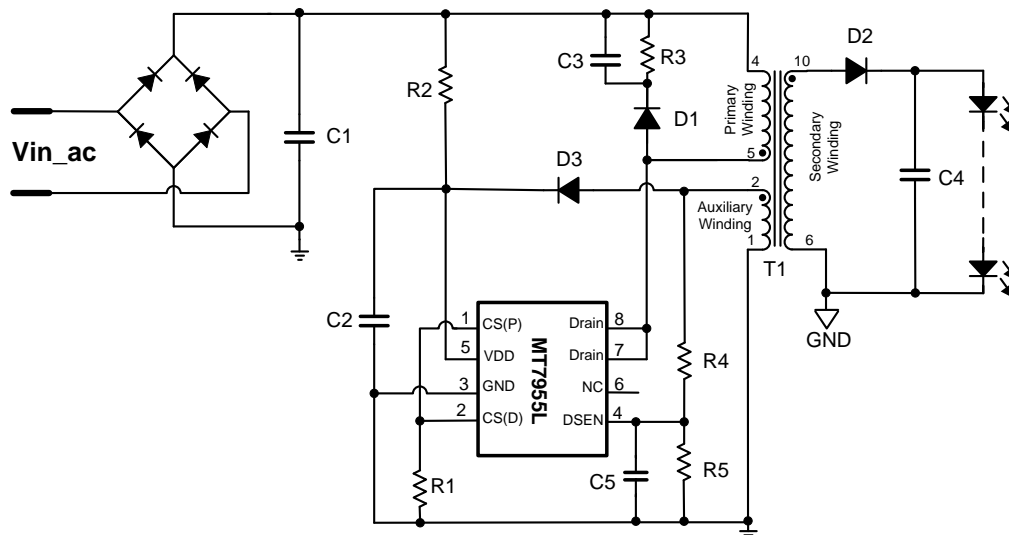



MT7955L

Maximizing IC Performance

High Accuracy, Primary-side AC-DC LED Driver

ABSOLUTE MAXIMUM RATINGS

VDD	-0.3V to 20V
DSEN	-0.3V to 6V
DRAIN	-0.3V to 600V
CS(P), CS(D)	-0.3V to 6V
P _{DMAX} (Maximum Power)	1.2W
Storage Temperature	-55°C to 150°C
Junction Temperature (T _j)	150°C

Recommended operating conditions

Supply voltage	7.5V to 16V
Operating Temperature	-40°C to 105°C

Thermal resistance

Case to ambient (R _{θCA})	70°C/W
-------------------------------------	--------

PIN CONFIGURATIONS

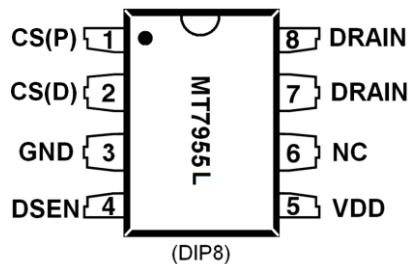

Chip Mark

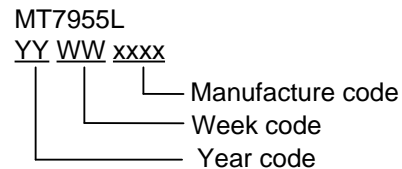

PIN DESCRIPTION

Name	Pin No.	Description
CS(P)	1	Current sense pin (Power line). Connect to sense resistor.
CS(D)	2	Current sense pin (Detection line). Normally, directly short to CS(P) pin on PCB. In some cases, there is large switching noise appears in CS(P) pin because of larger transformer leakage inductance, a RC filter can be added between Pin1 and Pin2. R=470ohm, C=47pF. Refer to Fig.3
GND	3	Ground
DSEN	4	The voltage feedback from auxiliary winding. Connected to a resistor divider from auxiliary winding reflecting output voltage. For further noise immunity, parallel a 22pF~47pF capacitor to GND.
VDD	5	Power Supply.
NC	6	No Connection
DRAIN	7,8	Drain of internal 600V NMOSFET

**MT7955L****Maximizing IC Performance****High Accuracy, Primary-side AC-DC LED Driver****ELECTRICAL CHARACTERISTICS**(Test conditions: $V_{DD}=12V$, $T_A=25^{\circ}C$ unless otherwise stated.)

Symbol	Parameter	Conditions	Min	Typ	Max	Unit
Start-up & Power supply (VDD Pin)						
I_{START}	Start-up Current			25	50	μA
UVLO	Lower Threshold Voltage of V_{DD}	V_{DD} Pin ramp down from 18V	6.6	7.2	7.5	V
V_{START}	Start-up Voltage	V_{DD} Pin ramp up from 0V	15	16	17	V
$V_{DD-CLAMP}$	VDD clamp voltage	$I_{DD}=10mA$	18.6	19.5	20.4	V
Operation Current						
I_Q	Operation current	$F_s=40kHz$		1.8		mA
Current Sense (CS Pin)						
V_{CS-TH}	Threshold Voltage of Peak Current Protection		487	500	513	mV
LEB1	Leading Edge Blanking at CS(D) Pin			500		nS
Auxiliary Winding Detection (DSEN Pin)						
V_{OV-TH}	The over voltage threshold at DSEN pin		2.15	2.3	2.5	V
LEB2	The Leading Edge Blanking at DSEN Pin			2.0		μS
Over Temperature Protection						
OTP	Over temperature protection threshold			155		$^{\circ}C$
	Over temperature protection release thysteresis			20		$^{\circ}C$
Power MOSFET (DRAIN Pin)						
$R_{DS(on)}$	Static drain-source on-resistance	$V_{GS}=10V/I_{DS}=0.5A$		6		Ω
BV_{DSS}	Drain-source breakdown voltage	$V_{GS}=0V/I_{DS}=250\mu A$	600			V
I_{DSS}	Drain-source leakage current	$V_{GS}=0V/V_{DS}=600V$			10	μA



MT7955L

Maximizing IC Performance

High Accuracy, Primary-side AC-DC LED Driver

BLOCK DIAGRAM

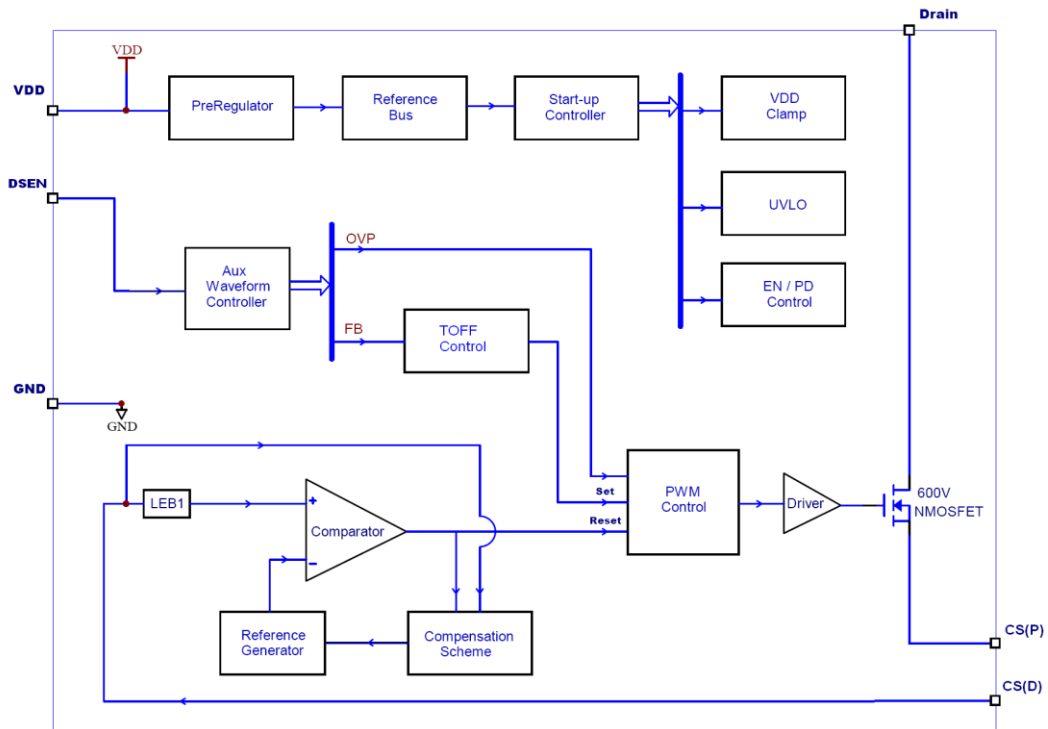

APPLICATION INFORMATION

MT7955L is a high performance power switch specially designed for LED lighting. It uses Maxim proprietary constant current regulation and compensation technology to achieve accurate LED current without opto-coupler and secondary side feedback circuit. MT7955L works in Discontinuous Conduction Mode (DCM). It integrates a 600V power MOSFET, minimizes the external component count, lower the total BOM cost.

Start Up

During start-up process, VDD is charged through a start-up resistor. As VDD reaches 16V, the control logic starts to work, and the power MOSFET begins to switch, as show in Fig.1.

The power supply is taken over by the auxiliary winding once the voltage of this winding is high enough.

MT7955L will shut down if VDD goes below 7.2V (UVLO threshold voltage).

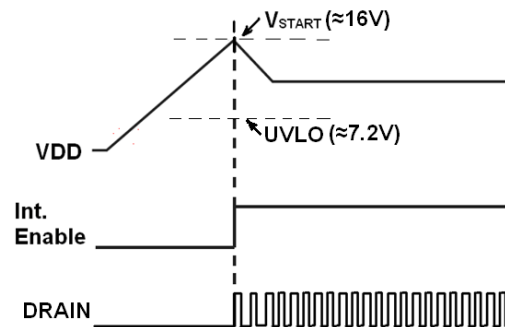

Fig.1 Start up sequence

Constant Current Control and Output Current Setup

Cycle-by-cycle current sense is offered in MT7955L, the CS(D) is connected to the current sense comparator, and the voltage on CS(D) is compared with the internal 500mV reference voltage, the MOSFET is turned off when the voltage on the CS(D) reaches the threshold. The



MT7955L

Maximizing IC Performance

High Accuracy, Primary-side AC-DC LED Driver

comparator also includes a 500nS leading edge blanking time to block the transient noise as the power switch just turned on.

The primary side peak current is given by:

$$I_{P_PK} = \frac{500}{R_{CS}} (mA)$$

where R_{CS} is the peak current sensing resistor, i.e. the resistor R1 in the application circuit in page 1.

The current in LED can be calculated by the following equation:

$$I_{LED} = \frac{I_{P_PK}}{4} \times \frac{N_P}{N_S} = \frac{500}{4 \times R_{CS}} \times \frac{N_P}{N_S} (mA)$$

where N_P is the turns of the primary winding, N_S is the turns of the secondary winding, I_{P_PK} is the primary side peak current. Shown in the above equation, the output current is determined by the turns ratio of the transformer and the current sense resistor value, insensitive to the inductance of the transformer.

Switching Frequency

MT7955L is designed to operating in discontinuous conduction mode and no external loop compensation is needed to maintain system stability. The maximum duty cycle is limited to 42%. It's highly recommended to limit the maximum switching frequency less than 100kHz and the minimum switching frequency more than 20kHz.

The switching frequency can be set by formula:

$$f_{SW} = \frac{N_P^2 \times V_{LED}}{8 \times N_S^2 \times L_p \times I_{LED}}$$

where, N_P is the turns of the primary winding, N_S is the turns of the secondary winding, L_p is the transformer primary winding inductance. Customer should set the switching frequency between 40kHz to 80kHz through properly design transformer parameters.

Auxiliary Winding Feedback and Sensing

MT7955L detects the secondary side output current through the feedback of the auxiliary winding. DSEN pin connect to auxiliary winding through an external resistor divider. To block the switching noise, a 2uS leading edge blanking time is embedded inside the chip. Refer to Fig.2. MT7955L features over-voltage protection (OVP), LED open circuit protection, turn-off time control functions. Those functions are triggered by sensing the auxiliary winding waveform information through DSEN pin.

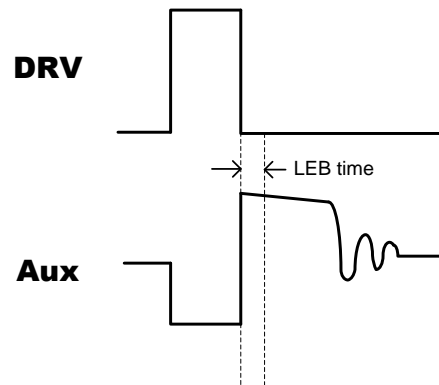

Fig.2 Auxiliary Signal Sensing

Over-voltage (LED open circuit) Protection

MT7955L is implemented with over-voltage protection scheme: If DSEN pin's voltage is detected above pre-determined threshold (2.3V) for four times, MT7955L turns off the PWM switching signal, and VDD voltage gradually drops to UVLO threshold, and the system will be re-started. The threshold voltage of over-voltage protection V_{OUT_OV} , can be easily defined as (refer to the application circuit in page 1):

$$V_{OUT_OV} = 2.3 \times \left(1 + \frac{R4}{R5}\right) \times \frac{N_S}{N_a} - V_{D2}$$

where N_S is the secondary winding, N_a is auxiliary winding, V_{D2} is the forward bias of the secondary side rectifier diode.

In addition, if VDD pin's voltage exceeds 19.5V,



MT7955L

Maximizing IC Performance

High Accuracy, Primary-side AC-DC LED Driver

the clamp circuit in MT7955L wakes up, clamps VDD voltage at 19.5V. It is highly recommended to set up the VDD voltage between 7.5V and 16V by designed a proper N_a to N_s ratio of the transformer.

Over-current Protection

MT7955L immediately turns off the power MOSFET once the voltage at CS(D) pin exceeds 500mV. This cycle by cycle current limitation scheme prevents the relevant components, such as power MOSFET, transformer, etc. from damage.

Primary side Peak Current Detection

MT7955L detects primary side peak current through CS(P) and CS(D) pin cycle-by-cycle. CS(P) is the source terminal of internal power MOSFET, externally connect a sense resistor between CS(P) and ground. CS(D) is the internal comparator input terminal. Normally, just short CS(D) with CS(P) on the PCB.

In some cases, because of transformer leakage inductance or PCB routing issue, there is large switching noise on CS(P) pin. This noise will affect the peak current detection on CS(D) pin. In this case, a RC filter can be added between CS(P) and CS(D) pin. $R=470\text{ohm}$, $C=47\text{pF}$. Refer to Fig. 3.

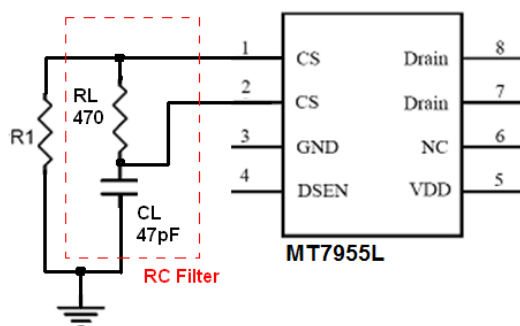

Fig.3 RC Filter Between CS(P) and CS(D)

PCB Layout

The following rules should be followed in MT7955L PCB layout:

Bypass Capacitor

The bypass capacitor on VDD should be as close as possible to the VDD pin.

Ground Path

The power ground path for current sense should be short, and the power ground path should be separated from small signal ground path before the negative of the bulk capacitor.

The Area of Power Loop

The area of main current loop should be as small as possible to reduce EMI radiation, such as the primary current loop, the snubber circuit and the secondary rectifying loop.

DRAIN pin

Increase the copper area of the drain terminal for thermal consideration.

NC pin

NC pin must left floating to satisfy the requirement of creepage distance.



MT7955L

Maximizing IC Performance

High Accuracy, Primary-side AC-DC LED Driver

PACKAGE INFORMATION

DIP-8 (8-Lead Dual In-Line)

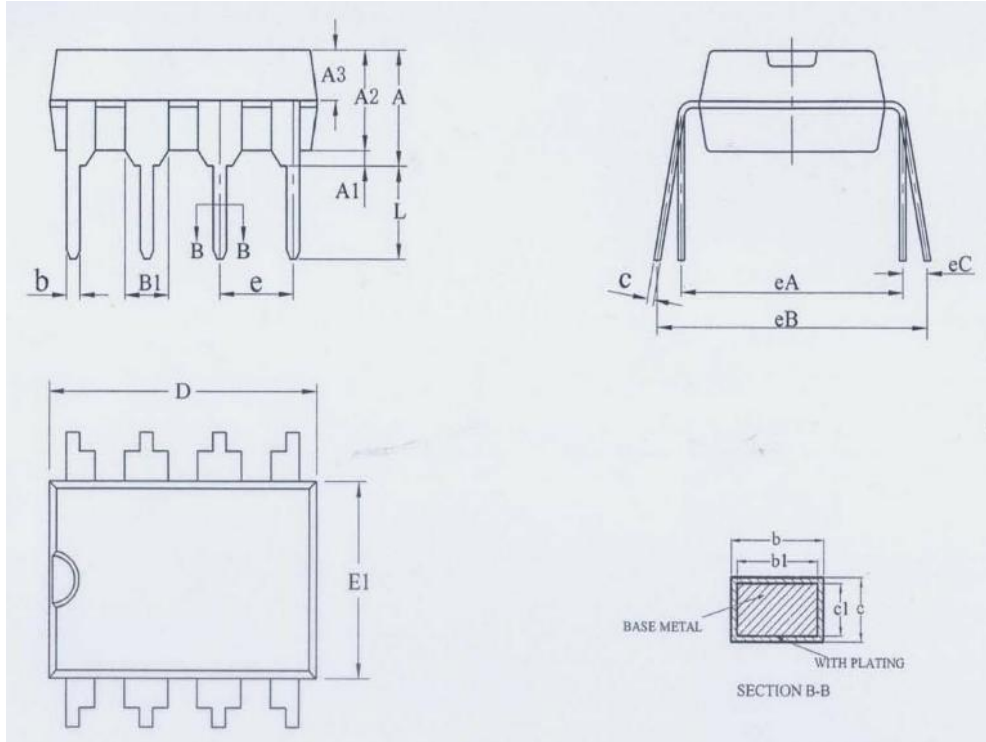

SYMBOL	MILLIMETER		
	MIN	NOM	MAX
A	3.60	3.80	4.00
A1	0.51	—	—
A2	3.00	3.30	3.40
A3	1.55	1.60	1.65
b	0.44	—	0.53
b1	0.43	0.46	0.48
B1	1.52BSC		
c	0.24	—	0.32
c1	0.23	0.25	0.27
D	9.05	9.25	9.45
E1	6.15	6.35	6.55
e	2.54BSC		
eA	7.62BSC		
eB	7.62	—	9.30
eC	0	—	0.84
L	3.00	—	—
L/F载体尺寸 (mil)	80*80		