

DESCRIPTION

MT7958 is a primary-side controller for AC-DC LED lighting. It operates in constant current control mode and works in discontinuous conduction mode, suitable for flyback converter under universal input.

MT7958 adopts primary side sensing and regulation technology, no secondary side feedback circuit is needed. Further, the loop compensation components are also eliminated while maintaining system stability. With building in 600V power MOSFET, low component counts and low BOM cost are achieved.

By using Maxic proprietary current regulation method, the MT7958 achieves $\pm 3\%$ accuracy of LED current along with excellent line regulation and load regulation.

MT7958 provides plenty of protections, such as LED short circuit protection, LED open circuit protection, over-temperature protection, VDD over voltage protection, VDD under voltage lock-out, etc.

FEATURES

- Build in 600V power MOSFET
- 85V to 265V AC line voltage range
- Primary side sensing and regulation, no need of secondary side feedback
- High precision constant LED current ($\pm 3\%$)
- Cycle-by-cycle peak current control
- LED short-circuit/open circuit protection
- VDD under voltage lock-out protection
- VDD over voltage protection
- Over temperature protection
- Built-in leading edge blanking (LEB)
- Extremely minimum external components
- Available in DIP8 package

APPLICATION

- E14/E27/PAR30/PAR38/GU10 LED lamp
- LED lighting application
- General purpose constant current source

Typical Application Circuit

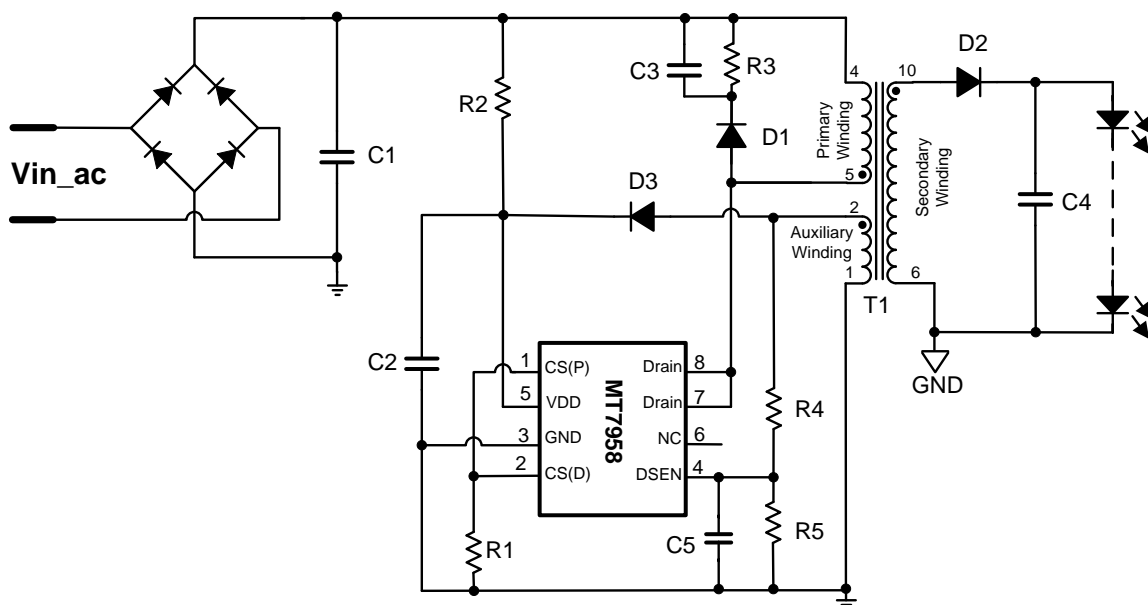

ABSOLUTE MAXIMUM RATINGS

VDD Pin Voltage	-0.3V to 20V
DSEN Pin Voltage	-0.3V to 6V
DRAIN Pin Voltage	-0.3V to 600V
CS(P), CS(D) Pins Voltage	-0.3V to 6V
P _{DMAX} (Maximum Power)	1W
Storage Temperature	-55°C to 150°C
Junction Temperature (T _j)	150°C

RECOMMENDED OPERATING CONDITIONS

Supply voltage	7.5V to 16V
Operating Temperature	-40°C to 105°C

THERMAL RESISTANCE

Junction to ambient (R _{θJA})	70°C/W
---	--------

PIN CONFIGURATIONS

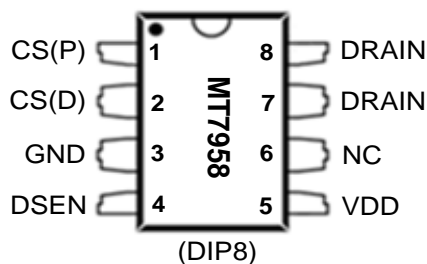

Chip Mark

MT7958

XX Y WW XX

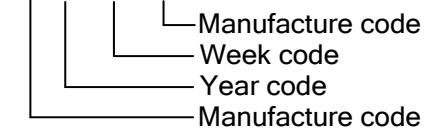

PIN DESCRIPTION

Name	Pin No.	Description
CS(P)	1	Current sense pin (Power line). Connect to sense resistor.
CS(D)	2	Current sense pin (Detection line). Normally, directly short to CS(P) pin on PCB. In some cases, there is large switching noise appears in CS(P) pin because of larger transformer leakage inductance, a RC filter can be added between Pin1 and Pin2. R=470ohm, C=47pF. Refer to Fig.3
GND	3	Ground
DSEN	4	The voltage feedback from auxiliary winding. Connected to a resistor divider from auxiliary winding reflecting output voltage. For further noise immunity, parallel a 22pF~47pF capacitor to GND.
VDD	5	Power Supply.
NC	6	No Connection
DRAIN	7,8	Drain of internal MOSFET