

DESCRIPTION

MT7966A is a high precision primary-side feedback and regulation controller for LED lighting. It regulates precisely LED current in isolated lighting applications. MT7966A works under Discontinuous Conduction Mode (DCM). It simplifies LED lighting system by eliminating the secondary sense, the auxiliary winding and feedback circuit. Integrated with 650V power switch, the adjustable LED open-circuit voltage protection (OVP) function simplifies the system design and improves the reliability.

With Maxic's proprietary current regulation and internal compensation technique, the MT7966A achieves $\pm 5\%$ accuracy of LED current along with excellent line regulation and load regulation. It is also non-sensitive to the inductance of the transformer.

MT7966A provides various protection features to improve the system reliability, including over current protection (OCP), short circuit protection (SCP), over voltage protection (OVP) and over temperature protection (OTP), etc.

FEATURES

- Internal 650V power MOSFET
- No auxiliary winding
- Supporting 85V to 265V AC line voltage range
- Primary side sensing and regulation, no secondary side feedback
- High precision constant LED current ($\pm 5\%$)
- Adjustable LED open-circuit voltage protection threshold
- LED short circuit protection
- Cycle-by-cycle peak current control
- VDD under voltage lock-out protection
- Over temperature protection
- Available in SOP8 package

APPLICATION

- LED bulb, spotlight
- LED lighting application
- General purpose constant current source

Typical Application Circuit

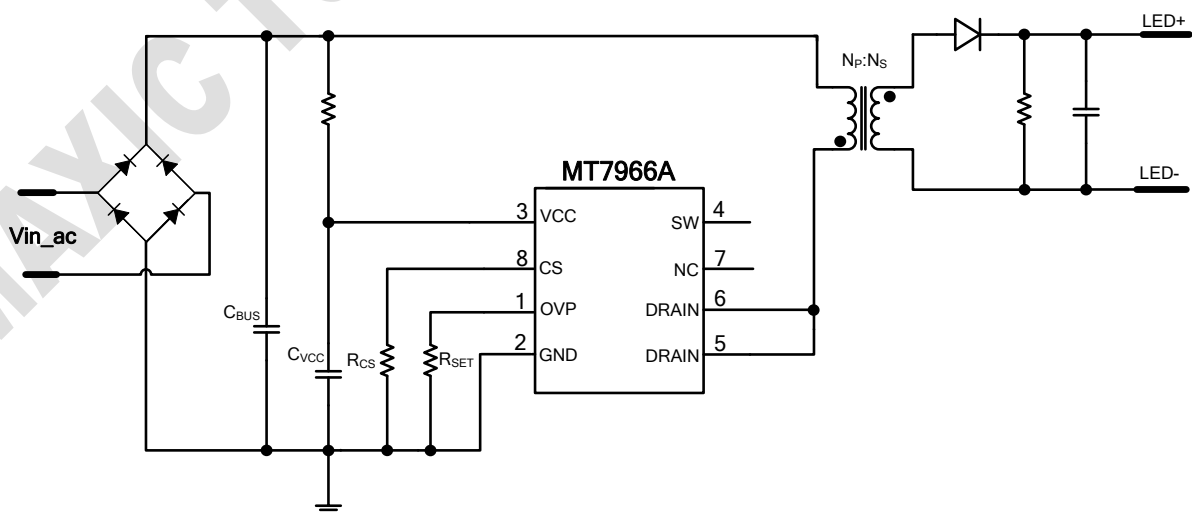

ABSOLUTE MAXIMUM RATINGS

DRAIN	-0.3V to 650V
VCC	-0.3V to 40V
VCC maximum sink current	5mA
OVP, CS	-0.3V to 6V
P _{DMAX} (Maximum Power)	0.8W
Storage Temperature	-55°C to 150°C
Junction Temperature (T _j)	150°C

Recommended operating conditions

Supply voltage	8V to 15V
Operating Temperature (Environment)	-40°C to 125°C

Thermal resistance^①

Junction to ambient (R _{θJA})	128°C/W
Junction to Case (R _{θJC})	90°C/W

Note:

- ① R_{θJA}, R_{θJC} are measured in the natural convection at TA = 25°C on a low effective single layer thermal conductivity test board of JEDEC 51-3 thermal measurement standard. Test condition: Device mounted on 2" X 2" FR-4 substrate PCB, 2oz copper, with minimum recommended pad on top layer and thermal vias to bottom layer ground plane.

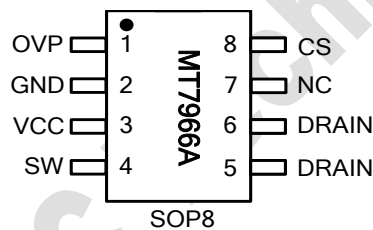
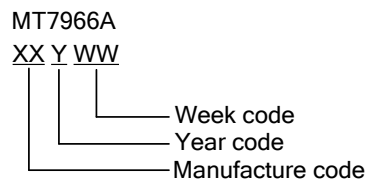
PIN CONFIGURATIONS

Chip Mark

PIN DESCRIPTION

Name	Pin No.	Description
OVP	1	LED open-circuit voltage protection setting pin. Refer to <i>LED Open Circuit Protection</i> section.
GND	2	Ground
VCC	3	Power supply
SW	4	Internal power MOS source
DRAIN	5,6	Internal power MOS drain
NC	7	No connection. This pin must be floating.
CS	8	Current sense pin, a sense resistor is connected between CS and GND