

Features

- AAL1 Segmentation and Reassembly device capable of simultaneously processing up to 2048 bidirectional VCs
- AAL1 cell format for "Structured DS1/E1 N x 64kbps Service" as per ATM Forum AF-VTOA-0078.000 "Circuit Emulation Services Interoperability Specifications" (Nx64 Basic Service, DS1 Nx64 Service with CAS, and E1 Nx64 Service with CAS)
- Two UTOPIA ports (Level 2, 16-bit, 50 MHz) with loopback function for dual fibre ring applications
- Third UTOPIA port for connection to an external AAL5 SAR processor, or for chaining multiple MT90503 or other SAR or IMA devices
- Flexible aggregation capabilities (Nx64) to allow any combination of 64 Kbps
- TDM bus provides 32 bidirectional serial TDM streams at 2.048, 4.096, or 8.192 Mbps for up to 4096 TDM 64 Kbps channels
- Compatible with H.100 and H.110 interfaces

Ordering Information

MT90503AG 503 Pin PBGA

For temperature range, see page 207.

- TDM to ATM transmission latency less than 250 μ s
- Support for clock recovery - Adaptive Clock Recovery, Synchronous Residual Time Stamp (SRTS) or external
- Support master and slave TDM bus clock operation
- 8- or 16-bit microprocessor port, configurable to Motorola or Intel timing
- Master clock rate up to 80 MHz
- Single power supply device (3.3V)
- IEEE 1149 (JTAG) interface

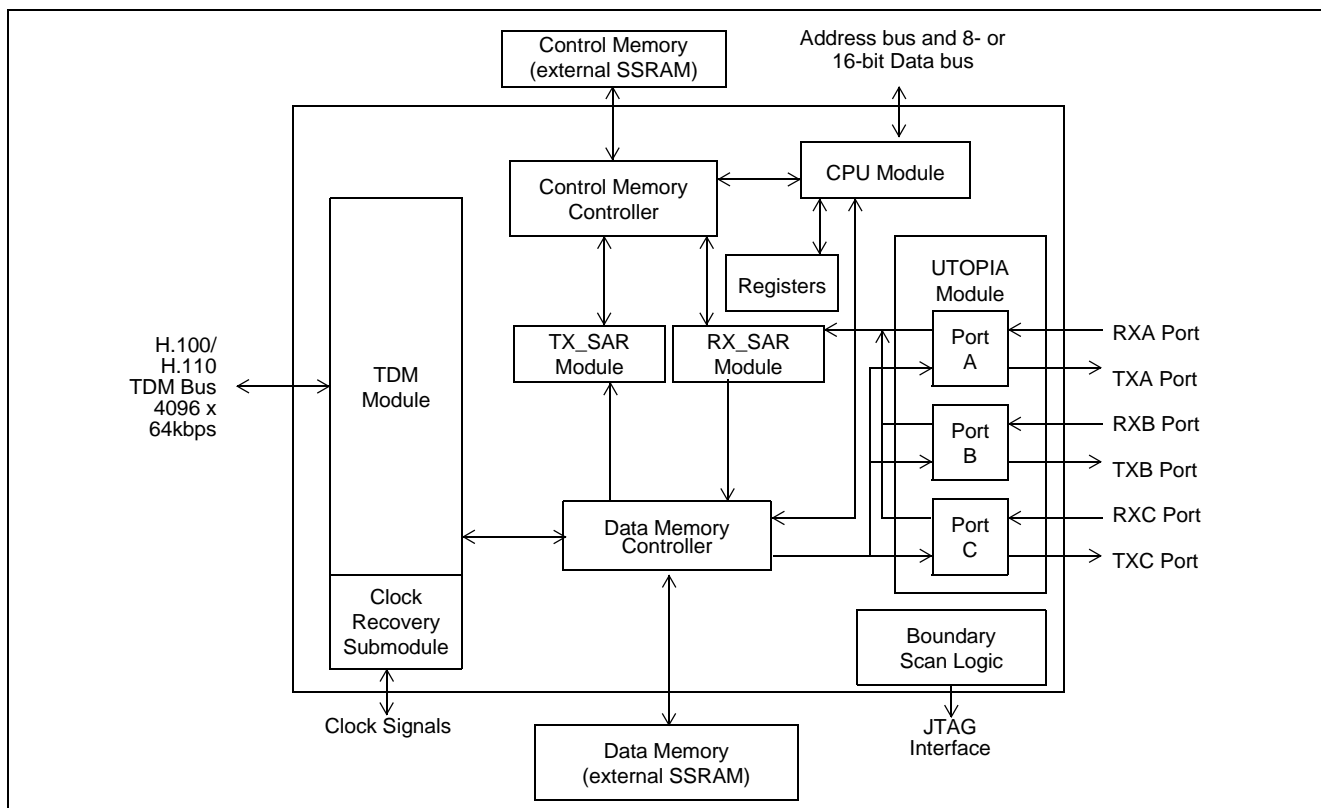

Figure 1 - Functional Block Diagram

Description

The MT90503 is an AAL1 SAR, which offers a highly integrated solution for interfacing telecom bus-based systems with ATM networks. The device has the capability of simultaneously processing 2048 bidirectional channels of 64 kbps. The MT90503 can be connected directly to an H.100 or H.110 compatible bus. The device also offers the capability of using Channel Associated Signalling (CAS) to support Circuit Emulation Service (CES) for Structured Data Transfer (SDT).

The interface to the TDM port is provided by a TDM bus, which consists of 32 bidirectional serial TDM data streams at 2.048, 4.096, or 8.192 Mbps, therefore allowing for 2048 bidirectional TDM channels operating at 64 kbps. This TDM bus is compatible with the ECTF H.100 and H.110 specifications.

The interface to the ATM domain is provided by three UTOPIA ports (Ports A, B, and C). All three of the UTOPIA ports can operate in ATM (master) or PHY (slave) mode. Port A can also be configured as Level 2 M-PHY mode.

Applications

- ATM Access and Multiplexing Equipment
- Switching Platforms that provide internetworking between TDM and ATM
- ATM Edge Switches
- ATM uplink for expansion of COs, PBXs, or open switching platforms using an adjunct ATM switch
- Integrated Digital Loop Carrier (IDLC)
- SONET or SDH Add and Drop Multiplexers (ADM)
- Next Generation Digital Loop Carrier (NGDIC)
- Digital Subscriber Line Access Multiplexer DSLAM with Gateway

Switching Feature

- Cells coming in from any of the UTOPIA ports can be switched to any other port. The user has the option to change the VPI and VCI fields.

PURCHASE OF THIS PRODUCT DOES NOT GRANT THE PURCHASER ANY RIGHTS UNDER PATENT NO. 5,260,978. USE OF THIS PRODUCT OR ITS RE-SALE AS A COMPONENT OF ANOTHER PRODUCT MAY REQUIRE A LICENSE UNDER THE PATENT WHICH IS AVAILABLE FROM TELCORDIA TECHNOLOGIES, INC., 445 SOUTH STREET , MORRISTOWN, NEW JERSEY 07960.

ZARLINK ASSUMES NO RESPONSIBILITY OR LIABILITY THAT MAY RESULT FROM ITS CUSTOMERS' USE OF ZARLINK PRODUCTS WITH RESPECT TO THIS PATENT. IN PARTICULAR, ZARLINK'S PATENT INDEMNITY IN ITS TERMS AND CONDITIONS OF SALES WHICH ARE SET OUT IN ITS SALES ACKNOWLEDGEMENTS AND INVOICES DOES NOT APPLY TO THIS PATENT.

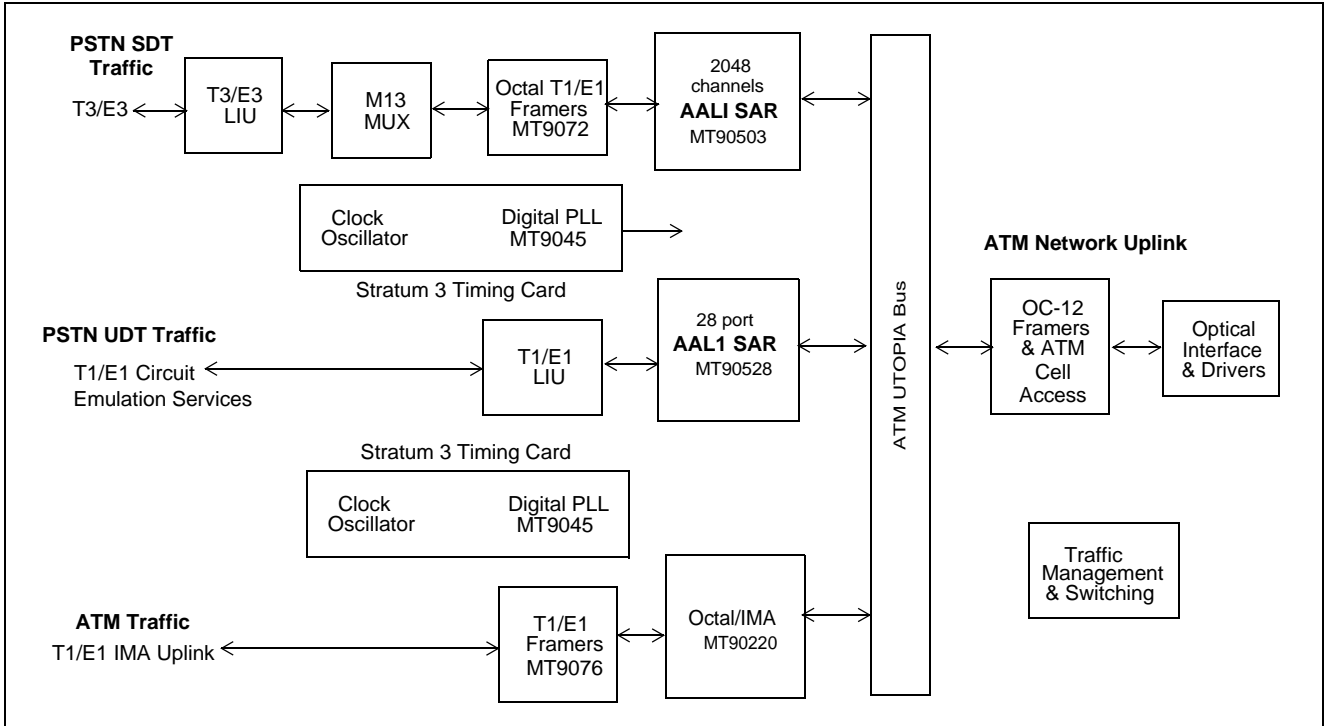

Figure 2 - ATM Switch Application

Table of Contents

1.0 Introduction	16
1.1 Functional Overview of the MT90503	16
2.0 Features Detailed Description	17
2.1 UTOPIA Interface	17
2.2 TDM Interface	18
2.3 Clock Recovery	18
2.4 ATM SAR	18
2.5 Required External Components	19
2.6 Particular Modes of Operation	19
2.7 Miscellaneous	19
2.8 Power	20
3.0 Pin Designations and Descriptions	20
4.0 Functional Description	34
4.1 CPU Interface	34
4.1.1 CPU Interrupts	35
4.1.1.1 Example Interrupt Flow	35
4.1.1.2 Interrupt Initialization	35
4.1.1.3 Interrupt Servicing	35
4.1.2 Intel/Motorola Interface	36
4.1.2.1 Extended Indirect Accessing	38
4.1.2.2 Extended Indirect Writes	38
4.1.2.3 Extended Indirect Reads	38
4.1.2.4 Extended Direct Accessing	38
4.1.2.5 Extended Direct Writes	39
4.1.2.6 Extended Direct Reads	39
4.1.3 MT90503 Reset Procedure	39
4.2 TDM Module	40
4.2.1 TDM Bus Interface	40
4.2.2 TDM Bus Clocking Mechanism	42
4.2.3 TDM Datapath	42
4.2.4 TDM Channel Association Structures	43
4.2.4.1 Non CAS Operation	43
4.2.4.2 CAS Operation	45
4.2.5 TDM Circular Buffers	48
4.2.6 TDM Circular Buffer Pointers	51
4.2.6.1 Non-multiframe mode	51
4.2.6.2 E1/T1 Multiframe (standard)	52
4.3 TX_SAR Module	57
4.3.1 Overview	57
4.3.1.1 Support and Trunking for Different Types of ATM Cells	57
4.3.2 TX_SAR Event Schedulers	58
4.3.2.1 Overview	58
4.3.2.2 The Transmit Event Scheduler Process	58
4.3.2.3 Transmit Event Scheduler Fields Description	60
4.3.2.4 Scheduler Events Fields Description	61
4.3.2.5 Bandwidth Limitations for Transmit Scheduler Events	61
4.3.3 Out of Bandwidth Error	62
4.3.3.1 Percent of Bandwidth Register	63
4.3.3.2 Distribution of Events by Software	63
4.3.4 Mapping of the Transmit Event Scheduler	63
4.3.5 TX_SAR Control Structures	64
4.3.5.1 TX_SAR Control Structure Fields	65

Table of Contents

4.3.6 Miscellaneous TX_SAR Features	69
4.3.6.1 T1 with CAS and E1 with CAS Cell Format Mapping	69
4.3.6.2 Support of Partially-Filled Cells	70
4.3.6.3 TX_SAR FIFO	70
4.4 RX_SAR Module	70
4.4.1 Treatment of Data Cells	70
4.4.2 Control Structure	70
4.4.3 Errors	75
4.4.4 Error Report Structure	76
4.5 UTOPIA Module	79
4.5.1 Overview	79
4.5.2 UTOPIA Interfaces	79
4.5.3 Errors on received cells	80
4.5.4 Transmit and Receive State Machines for ATM and PHY Modes	81
4.5.5 Cell Router	82
4.5.6 Match & Mask for cell routing	83
4.5.6.1 Look-Up Tables Entries	84
4.5.6.2 LUT Addressing	84
4.5.6.3 UTOPIA Clocks	85
4.5.7 LED Operation	85
4.5.8 UTOPIA Flow Control	86
4.5.9 External Interface Signals	86
4.6 Clock Recovery Module	87
4.6.1 Overview	87
4.6.1.1 Two Point Generation Modules	87
4.6.1.2 One SRTS (synchronous residual time stamp) Generating Module	87
4.6.1.3 Three Integer Divisor Clock Modules	87
4.6.1.4 Two Precise Clock Modules	88
4.6.1.5 Eleven Multiplexers	88
4.6.2 Multiplexers	88
4.6.3 Integer Divisor Clocks (idclk)	90
4.6.4 Precise Clocks (pclk)	92
4.6.5 Point Generation	93
4.6.6 Adaptive Clock Recovery	95
4.6.6.1 SRTS Clock Recovery	96
4.6.7 SRTS Transmission	97
4.6.8 External Memory Point Format	98
5.0 Memory	100
5.1 Memory Overview	100
5.2 Memory Map	101
5.3 Memory Controllers	101
5.3.1 Data Memory	101
5.3.2 Control Memory	102
5.3.3 Data Memory Controller	102
5.3.4 Control Memory Controller	103
5.4 Register Overview	103
5.5 Detailed Register Description	104
5.5.1 CPU Registers	104
5.5.2 Main Registers	110
5.5.3 UTOPIA Registers	121
5.5.4 TDM Registers	152
5.5.5 TX_SAR Registers	156

Table of Contents

5.5.6 Scheduler Registers	159
5.5.7 RX_SAR Registers	162
5.5.8 Clock Registers	167
5.5.9 Miscellaneous Registers	193
5.5.10 H.100 Registers	200
6.0 Statistics	203
6.1 TDM statistics	203
6.2 TX SAR statistics	203
6.3 RX SAR statistics	203
6.4 UTOPIA statistics	204
7.0 Programming the fast_clk PLL	204
8.0 Electrical Specifications	207
8.1 DC Characteristics	207
8.1.1 Precautions During Power Sequencing	209
8.1.2 Precautions During Power Failure	209
8.1.3 Pull-ups	209
8.2 H.110 Diode Clamp Rail	209
8.3 AC Characteristics	210
9.0 Interface Timing	211
9.1 CPU Interface Timing	211
9.2 UTOPIA Interface Timing	219
9.3 External Memory Timing	220
9.4 H.100/H.110 Interface Timing	225
9.5 H.100/H.110 Clocking Signals	227
10.0 Glossary of Terms	230

List of Figures

Figure 1 - Functionl Block Diagram	1
Figure 2 - ATM Switch Application	3
Figure 3 - Transmit Data Flow - TDM to UTOPIA	16
Figure 4 - Receive Data Flow - UTOPIA to TDM	17
Figure 5 - PLL Pin Connections	34
Figure 6 - TDM Serial to Parallel/Parallel to Serial (SPPS) Converter	41
Figure 7 - CAS and MFS Transport on the TDM Bus	41
Figure 8 - TDM Data Path Controller	43
Figure 9 - TDM Channel Association Structures: TX Channel non-CAS mode	43
Figure 10 - TDM Channel Association: RX Channels (Non CAS mode)	44
Figure 11 - TDM Channel Association: TX Channels (CAS mode)	45
Figure 12 - TDM Channel Association: RX Channels (CAS mode)	46
Figure 13 - CAS Change Structure in Control Memory	47
Figure 14 - TX/RX Circular Buffer and Size Field	47
Figure 15 - Silent Pattern Buffer A/B in Control Memory	48
Figure 16 - TDM Circular Buffer (one MultiFrame in T1 mode)	49
Figure 17 - TDM Circular Buffer (one Super Frame in E1 mode)	50
Figure 18 - TDM Circular Buffers (Normal mode)	51
Figure 19 - TDM Circular Buffer (Complete Buffer in E1 mode, Strict Multiframeing)	53
Figure 20 - TDM Circular Buffer (Complete Buffer in E1 mode, FASTCAS)	54
Figure 21 - TDM Circular Buffer (Complete Buffer in T1 mode, Strict Multiframeing)	55
Figure 22 - TDM Circular Buffer (Complete Buffer in T1 mode, FASTCAS)	56
Figure 23 - ATM Cell Formats	57
Figure 24 - Transmit Event Scheduler Process	59
Figure 25 - Unsynchronised Schedulers	62
Figure 26 - Synchronised Schedulers	62
Figure 27 - Partially Synchronised Schedulers	62
Figure 28 - TX_SAR Event Scheduler Pointer Flow and Control Structure	64
Figure 29 - TX_SAR Control Structure	65
Figure 30 - RX_SAR Control Structure	71
Figure 31 - Overrun and Underrun Examples	76
Figure 32 - RX_SAR Error Report Structure	77
Figure 33 - UTOPIA Module	79
Figure 34 - ATM Mode State Machines	81
Figure 35 - PHY Mode State Machines	81
Figure 36 - Cell Format for cells in internal UTOPIA input and output cell FIFOs	82
Figure 37 - Cell Router Flow	83
Figure 38 - Match & Mask Example	83
Figure 39 - Short and Long Look-Up Table Entries	84
Figure 40 - VPI/VCI Concatenation and LUT Entry Address Example	85
Figure 41 - UTOPIA Clock Generation	86
Figure 42 - External UTOPIA Interface	87
Figure 43 - Multiplexer	89
Figure 44 - Integer Clock Processor	92
Figure 45 - Adaptive Clock Recovery	95
Figure 46 - Adaptive Cell Reception Flow	96
Figure 47 - Rx SRTS Clock Recovery Module	97
Figure 48 - Tx SRTS Clock Recovery Module	98

List of Figures

Figure 49 - Clock Recovery Information Buffers	99
Figure 50 - mem_clk Output and fast_clk Generation Circuits.	205
Figure 51 - mem_clk Input and mclk Generation Circuit	205
Figure 52 - Non-multiplexed CPU Write Access - Intel Mode	211
Figure 53 - Non-multiplexed CPU Read Access - Intel Mode	211
Figure 54 - Multiplexed CPU Write Access - Intel Mode	212
Figure 55 - Multiplexed CPU Read Access - Intel Mode	213
Figure 56 - Non-Multiplexed CPU Interface Write Access - Motorola Mode	214
Figure 57 - Non-multiplexed CPU Interface Read Access - Motorola Mode	215
Figure 58 - Multiplexed CPU Interface Write Access - Motorola Mode	216
Figure 59 - Multiplexed CPU Interface Read Access - Motorola Mode	217
Figure 60 - UTOPIA Timing	219
Figure 61 - Flowthrough ZBT External Memory Timing - Write Access.	220
Figure 62 - Flowthrough ZBT External Memory Timing - Read Access.	220
Figure 63 - Flowthrough SSRAM External Memory Timing - Write Access	221
Figure 64 - Flowthrough SSRAM External Memory Timing - Read Access.	221
Figure 65 - Late-write External Memory Timing - Write Access.	222
Figure 66 - Late-write External Memory Timing - Read Access.	222
Figure 67 - Pipelined ZBT External Memory Timing - Write Access	223
Figure 68 - Pipelined ZBT External Memory Timing - Read Access	223
Figure 69 - Pipelined External Memory Timing - Write Access	224
Figure 70 - Pipelined External Memory Timing - Read Access	224
Figure 71 - H.100 Input, Output, and Frame Sampling	225
Figure 72 - H.100 Message Channel Clock, Transmission Delay, and Reception Delay.	226
Figure 73 - H.100 Clock Skew (when chip is Master)	226
Figure 74 - H.100/H.110 Clocking Signals	227
Figure 75 - TDM Bus Timing - Compatibility Clock Generation	228
Figure 76 - TDM Data Bus Timings	229

List of Tables

Table 1 - CPU Bus Interface Pins	21
Table 2 - Control Memory Bus Interface Pins	22
Table 3 - Data Memory Bus Interface Pins	23
Table 4 - Data and Control Memory Clock Pins	23
Table 5 - H.100/H.110 Bus Interface Pins	24
Table 6 - Clock Recovery Pins	25
Table 7 - Test Pins	25
Table 8 - UTOPIA Interface Pins	26
Table 9 - Phase Lock Loop (PLL) Pins	28
Table 10 - Process Monitor Pins	29
Table 11 - Pin Names Listed by Location	29
Table 12 - Pinout Summary	33
Table 13 - CPU Interface Mode Selection	36
Table 14 - Control Register (0000h)	37
Table 15 - Read/Write Data Register (0004h)	37
Table 16 - Address High Register (0008h)	37
Table 17 - Address Low Register (000Ah)	37
Table 18 - Field Description for the Transmit Event Scheduler	60
Table 19 - Scheduler Event Fields	61
Table 20 - Maximum number of Events per Frame for Common Transmission Speeds	61
Table 21 - Examples of typical Transmit Event Scheduler Sizes	63
Table 22 - Description of the Fields for the TX_SAR Control Structure	65
Table 23 - Description of the Fields for the RX_SAR Structure	71
Table 24 - Payload Sizes for Various Cell Formats	75
Table 25 - RX_SAR errors	75
Table 26 - Description of the Fields for the RX_SAR Error Report Structure	77
Table 27 - Multiplexer Registers	88
Table 28 - Source Selection	89
Table 29 - idclk_a Register	91
Table 30 - pclk registers	93
Table 31 - adapsrts0 Registers	93
Table 32 - Tx SRTS Registers	98
Table 33 - SRTS Pointer Buffer, Field Description	99
Table 34 - MT90503 Memory Map	101
Table 35 - Types of Data Memory accesses for each agent	102
Table 36 - Types of Control Memory Accesses For Each Agent	103
Table 37 - CPU Control Register	104
Table 38 - CPU Status Register	105
Table 39 - CPU Interrupt Enable Register	105
Table 40 - CPU Counter Register	105
Table 41 - LED1 Register	106
Table 42 - LED2 Register	106
Table 43 - PLL Configuration Register	106
Table 44 - Intel/Motorola Address Register	107
Table 45 - Intel/Motorola Address Rise Register	107
Table 46 - Intel/Motorola Address Fall Register	108
Table 47 - Intel/Motorola Data Out Register	108
Table 48 - Intel/Motorola Data In Register	109

List of Tables

Table 49 - Intel/Motorola Data Rise/Fall Register	110
Table 50 - Main Control Register	110
Table 51 - Main Status Register	111
Table 52 - Main Interrupt Enable Register	111
Table 53 - Main Counter Register	112
Table 54 - Interrupt Flags Register	112
Table 55 - Interrupt1 Configuration Register	113
Table 56 - Interrupt2 Configuration Register	114
Table 57 - Interrupt1 Enable Register	114
Table 58 - Interrupt2 Enable Register	115
Table 59 - Utopia Clock Register	116
Table 60 - Utopia Clock Generation A Register	117
Table 61 - Utopia Clock Generation B Register	118
Table 62 - Utopia Clock Generation C Register	118
Table 63 - Control Memory Parity0 Register	119
Table 64 - Control Memory Parity1 Register	119
Table 65 - Control Memory Configuration Register	120
Table 66 - Data Memory Parity 0 Register	120
Table 67 - Data Memory Parity 1 Register	121
Table 68 - Data Memory Configuration Register	121
Table 69 - Utopia Control Register	121
Table 70 - Utopia Control1 Register	122
Table 71 - Utopia Status 0 Register	123
Table 72 - Utopia Status 2 Register	124
Table 73 - Utopia Interrupt Enable 2 Register	124
Table 74 - Utopia Counters Register	125
Table 75 - Cell Loss Counters Register	126
Table 76 - Port A Look Up Table Address Register	126
Table 77 - Port A VPI/VCI Identification Register	126
Table 78 - Port A Concatenation Register	126
Table 79 - Port A VPI Match Register	127
Table 80 - Port A VCI Mask Register	127
Table 81 - Port A VCI Match Register	127
Table 82 - Port A VCI Mask Register	128
Table 83 - Port A Cell Arrival Counter High Register	128
Table 84 - Port A Cell Arrival Counter Low Register	128
Table 85 - Port A Cell Departure Counter High Register	128
Table 86 - Port A Cell Departure Low Register	129
Table 87 - Port A Overflow0 Register	129
Table 88 - Port A Overflow1 Register	129
Table 89 - Port A Address Register	130
Table 90 - Port B Look Up Table Register	130
Table 91 - Port B VPI/VCI Identification Register	130
Table 92 - Port B Concatenation Register	130
Table 93 - Port B VPI Match Register	131
Table 94 - Port B VPI Mask Register	131
Table 95 - Port B VCI Match Register	131
Table 97 - Port B Cell Arrival Counter High Register	132

List of Tables

Table 98 - Port B Cell Arrival Counter Low Register	132
Table 99 - Port B Cell Departure Counter High Register	132
Table 96 - Port B VCI Mask Register	132
Table 100 - Port B Cell Departure Counter Low Register	133
Table 101 - Port B Overflow0 Register.	133
Table 102 - Port B Overflow1 Register.	133
Table 103 - Port C Look Up Table Register	134
Table 104 - Port C VPI/VCI Identification Register.	134
Table 105 - Port C Concatenation Register	134
Table 106 - Port C VPI Match Register	134
Table 107 - Port C VPI Mask Register	135
Table 108 - Port C VCI Match Register	135
Table 109 - Port C VCI Match Register	135
Table 110 - Port C Cell Arrival Counter High Register	136
Table 111 - Port C Cell Arrival Counter Low Register	136
Table 112 - Port C Cell Departure Counter High Register	136
Table 113 - Port C Cell Departure Counter Low Register	136
Table 114 - Port C Overflow0 Register.	137
Table 115 - Port C Overflow1 Register.	137
Table 116 - TX_SAR Cell Arrival Counter High Register	137
Table 117 - TX_SAR Cell Arrival Counter Low Register	138
Table 118 - RX_SAR Cell Departure Counter High Register	138
Table 119 - RX_SAR Cell Departure Counter Low Register	138
Table 120 - TX_SAR Overflow0 Register.	138
Table 121 - TX_SAR Overflow1 Register.	139
Table 122 - HEC Byte Control Register	139
Table 123 - Unknown Header Routing Register.	139
Table 124 - Unknown OAM Routing Register	140
Table 125 - GPIO Input0 Register	140
Table 126 - GPIO Input1 Register	140
Table 127 - GPIO Input2 Register	141
Table 128 - TXA Data Status Register	141
Table 129 - TXA Data Interrupt Enable Register	142
Table 130 - RXA Data Status Register	143
Table 131 - RXA Data Interrupt Enable Register	143
Table 132 - TXB Data Status Register	144
Table 133 - TXB Data Interrupt Enable Register	145
Table 134 - RXB Data Status Register.	147
Table 135 - RXB Data Interrupt Enable Register	147
Table 136 - GPIO Status Register	148
Table 137 - GPIO Status Register	149
Table 138 - GPIO Output0 Register.	150
Table 139 - GPIO Output1 Register.	150
Table 140 - GPIO Output2 Register.	150
Table 141 - GPIO Output Enable0 Register.	151
Table 142 - GPIO Output Enable1 Register.	151
Table 143 - GPIO Output Enable2 Register.	152
Table 144 - TDM Control Register	152

List of Tables

Table 145 - TDM Status Register	153
Table 146 - Cut VC TSST Register	153
Table 147 - TSST Underrun Register	153
Table 148 - TSST CAS Underrun Register	154
Table 149 - TDM Interrupt 0 Register	154
Table 150 - TDM Interrupt 1 Register	154
Table 151 - TDM Interrupt Enable Misc. Register	155
Table 152 - TDM Write Pointer 0 Register	155
Table 153 - TDM Write Pointer 1 Register	156
Table 154 - TDM Read Pointer Register	156
Table 155 - TX_SAR Control Register	156
Table 156 - TX_SAR Status Register	157
Table 157 - TX_SAR Interrupt Enable Register	157
Table 158 - TX_SAR Control 1 Register	157
Table 159 - TX_SAR Data Read Pointer Register	158
Table 160 - TX_SAR Data Write Pointer Register	158
Table 161 - TX_SAR Data Address Register	158
Table 162 - TX_SAR Data Cell Size Register	158
Table 163 - Percent of Bandwidth Register	159
Table 164 - Scheduler Test Status Register	159
Table 165 - Scheduler Status Register	159
Table 166 - Scheduler Interrupt Enable Register	159
Table 167 - Frame Latency Register	160
Table 168 - Scheduler Configuration & Enable 0 Register	160
Table 169 - Scheduler Configuration & Enable 1 Register	160
Table 170 - Scheduler Configuration & Enable 2 Register	161
Table 171 - Scheduler Configuration & Enable 3 Register	162
Table 172 - RX_SAR Control Register	162
Table 173 - RX_SAR Status Register	162
Table 174 - RX_SAR Interrupt Enable Register	163
Table 175 - RX_SAR Data Read Pointer Register	163
Table 176 - RX_SAR Data Write Pointer Register	164
Table 177 - RX_SAR Data Address Register	164
Table 178 - RX_SAR Data Cell Size Register	164
Table 179 - Error Structure Read Register	164
Table 180 - Error Structure Write Register	165
Table 181 - Error Structure Address High Register	165
Table 182 - Error Structure Address Low Register	165
Table 183 - Error Structure Size Register	165
Table 184 - AAL0 Timeout High Register	166
Table 185 - AAL0 Timeout Low Register	166
Table 186 - Error Timeout High Register	166
Table 187 - Error Timeout Low Register	166
Table 188 - Treated Pulses Register	167
Table 189 - Clock Control Register	167
Table 190 - Clock Status Register	167
Table 191 - Status Interrupt Enable Register	168
Table 192 - MCLK Alarm 0 Register	168

List of Tables

Table 193 - MCLK Counter High Register	168
Table 194 - MCLK Counter Low Register	168
Table 195 - MCLK Alarm 1 Register	169
Table 196 - MCLK Alarm 2 Register	169
Table 197 - TX_SRTS 0 Register	169
Table 198 - TX_SRTS 1 Register	170
Table 199 - TX_SRTS 2 Register	170
Table 200 - TX_SRTS 4 Register	170
Table 201 - TX_SRTS 5 Register	171
Table 202 - Adaptive SRTS0 0 Register	171
Table 203 - Adaptive SRTS0 1 Register	172
Table 204 - Adaptive SRTS0 2 Register	172
Table 205 - Adaptive SRTS0 3 Register	173
Table 206 - Adaptive SRTS0 4 Register	174
Table 207 - Adaptive SRTS0 5 Register	174
Table 208 - Adaptive SRTS0 6 Register	174
Table 209 - Adaptive SRTS0 7 Register	175
Table 210 - Adaptive SRTS0 8 Register	175
Table 211 - Adaptive SRTS0 9 Register	175
Table 212 - Adaptive SRTS1 0 Register	175
Table 213 - Adaptive SRTS1 1 Register	176
Table 214 - Adaptive SRTS1 2 Register	177
Table 215 - Adaptive SRTS1 3 Register	177
Table 216 - Adaptive SRTS1 4 Register	177
Table 217 - Adaptive SRTS1 5 Register	178
Table 218 - Adaptive SRTS1 6 Register	178
Table 219 - Adaptive SRTS1 7 Register	178
Table 220 - Adaptive SRTS1 8 Register	178
Table 221 - Adaptive SRTS1 9 Register	179
Table 222 - Pin Mux 0 Register	179
Table 223 - Pin Mux 1 Register	179
Table 224 - Pin Mux 2 Register	180
Table 225 - Pin Mux 3 Register	180
Table 226 - Pin Mux 4 Register	180
Table 227 - Pin Mux 5 Register	181
Table 228 - Integer Clock Divisor0 0 Register	181
Table 229 - Integer Clock Divisor0 1 Register	182
Table 230 - Integer Clock Divisor0 2 Register	182
Table 231 - Integer Clock Divisor0 3 Register	183
Table 232 - Integer Clock Divisor0 4 Register	183
Table 233 - Integer Clock Divisor0 5 Register	184
Table 234 - Integer Clock Divisor0 8 Register	184
Table 235 - Integer Clock Divisor0 9 Register	184
Table 236 - Integer Clock Divisor0 10 Register	185
Table 237 - Integer Clock Divisor1 0 Register	185
Table 238 - Integer Clock Divisor1 1 Register	185
Table 239 - Integer Clock Divisor1 2 Register	186
Table 240 - Integer Clock Divisor1 3 Register	186

List of Tables

Table 241 - Integer Clock Divisor1 4 Register	187
Table 242 - Integer Clock Divisor1 5 Register	187
Table 243 - Integer Clock Divisor1 8 Register	187
Table 244 - Integer Clock Divisor1 9 Register	188
Table 245 - Integer Clock Divisor1 10 Register	188
Table 246 - Integer Clock Divisor2 0 Register	188
Table 247 - Integer Clock Divisor2 1 Register	189
Table 248 - Integer Clock Divisor2 2 Register	189
Table 249 - Integer Clock Divisor2 3 Register	190
Table 250 - Integer Clock Divisor2 4 Register	190
Table 251 - Integer Clock Divisor2 5 Register	190
Table 252 - Integer Clock Divisor2 8 Register	191
Table 253 - Integer Clock Divisor2 9 Register	191
Table 254 - Integer Clock Divisor2 10 Register	191
Table 255 - TX SRTS Debug Register	191
Table 256 - RX SRTS Debug 0 Register	192
Table 257 - RX SRTS Debug 1 Register	192
Table 258 - AAL1 Error Debug Register	192
Table 259 - Miscellaneous Control Register	193
Table 260 - Miscellaneous Error Register	193
Table 261 - Silent Tone 2 Register	193
Table 262 - Silent Tone 3 Register	194
Table 263 - Silent Tone 4 Register	194
Table 264 - Adaptive Point/SRTS Value 0 Register	194
Table 265 - Adaptive Point/SRTS Base Address Low 0 Register	194
Table 266 - Adaptive Point/SRTS Base Address High 0 Register	195
Table 267 - Adaptive Point/SRTS Write Pointer 0 Register	195
Table 268 - Adaptive Point/SRTS Read Pointer 0 Register	195
Table 269 - Local SRTS Write Pointer 0 Register	195
Table 270 - Local SRTS Read Pointer 0 Register	196
Table 271 - Adaptive Point/SRTS Value 1 Register	196
Table 272 - Adaptive Point/SRTS Base Address Low 1 Register	196
Table 273 - Adaptive Point/SRTS Base Address High 1 Register	196
Table 274 - Adaptive Point/SRTS Write Pointer 1 Register	197
Table 275 - Adaptive Point/SRTS Read Pointer 1 Register	197
Table 276 - Local SRTS Write Pointer 1 Register	197
Table 277 - Local SRTS Read Pointer 1 Register	197
Table 278 - CAS Change Buffer Size Register	198
Table 279 - CAS Change Buffer Base Address Low Register	198
Table 280 - CAS Change Buffer Base Address High Register	198
Table 281 - CAS Write Pointer Register	198
Table 282 - CAS Read Pointer Register	199
Table 283 - CAS Timeout High Register	199
Table 284 - CAS Timeout Low Register	199
Table 285 - Treated Pulses Register	199
Table 286 - H.100 Control 0 Register	200
Table 287 - H.100 Control 1 Register	201
Table 288 - H.100 Control 2 Register	201

List of Tables

Table 289 - H.100 Flags Register	201
Table 290 - H.100 Status Register	202
Table 291 - H.100 Interrupt Enable Register	203
Table 292 - Register 0128h Frequency Values	206
Table 293 - Z Divisor Table	206
Table 294 - Clock Networks	210
Table 295 - MCLK - Master Clock Input Parameters	210
Table 296 - Non-multiplexed CPU Interface Intel Mode	212
Table 297 - Multiplexed CPU Interface Intel Mode	213
Table 298 - Non-multiplexed CPU Interface Motorola Mode	215
Table 299 - Multiplexed CPU Interface Motorola Mode	217
Table 300 - t5 Read Access Time	218
Table 301 - UTOPIA Bus Timing	219
Table 302 - Memory Interface Timing	225
Table 303 - H.100/H.110 Interface Timing	227
Table 304 - H.100/H.110 Clocking Signals	229

1.0 Introduction

1.1 Functional Overview of the MT90503

The MT90503 is an AAL1 SAR, which offers a highly integrated solution for interfacing telecom bus-based systems with ATM networks. The device has the capability of simultaneously processing 2048 bi-directional channels of 64 Kbps. The MT90503 can be connected directly to an H.100 or H.110 compatible bus. The device also offers the capability of using Channel Associated Signalling (CAS) to support Circuit Emulation Service (CES) for Structured Data Transfer (SDT).

The interface to the TDM port is provided by a TDM bus, which consists of 32 bi-directional serial TDM data streams at 2.048, 4.096, or 8.192 Mbps, therefore allowing for 2048 bi-directional TDM channels operating at 64 kbps. This TDM bus is compatible with the ECTF H.100 and H.110 specifications.

The interface to the ATM domain is provided by three UTOPIA ports (Ports A, B, and C). All three of the UTOPIA ports can operate in ATM (master) or PHY (slave) mode.

Port A is a UTOPIA Level 2 interface which can operate at up to 50 MHz using a 16- or an 8-bit data bus. This port is capable of operating in ATM-mode (single-PHY), in PHY-mode (slave-mode or level 1), or in slave MPHY-mode (Level 2).

Port B is a UTOPIA Level 2 interface, which can operate at up to 50 MHz using a 16- or an 8-bit data bus but does not support bus addressing. This port is capable of operating in ATM-mode (single-PHY), in PHY-mode (slave-mode).

Port C is a UTOPIA Level 1 interface which can operate at up to 50 MHz using an 8-bit data bus. This port is capable of operating in ATM-mode (master-mode), or in PHY-mode (slave-mode). The MT90503 is capable of performing a UTOPIA loopback from any incoming UTOPIA port to any outgoing UTOPIA port, including a loopback to the port of origin. The loopback capability could be used for dual fibre ring applications.

Figure 3 shows the data flow from the H.100/H.110 bus to the TX UTOPIA interface.

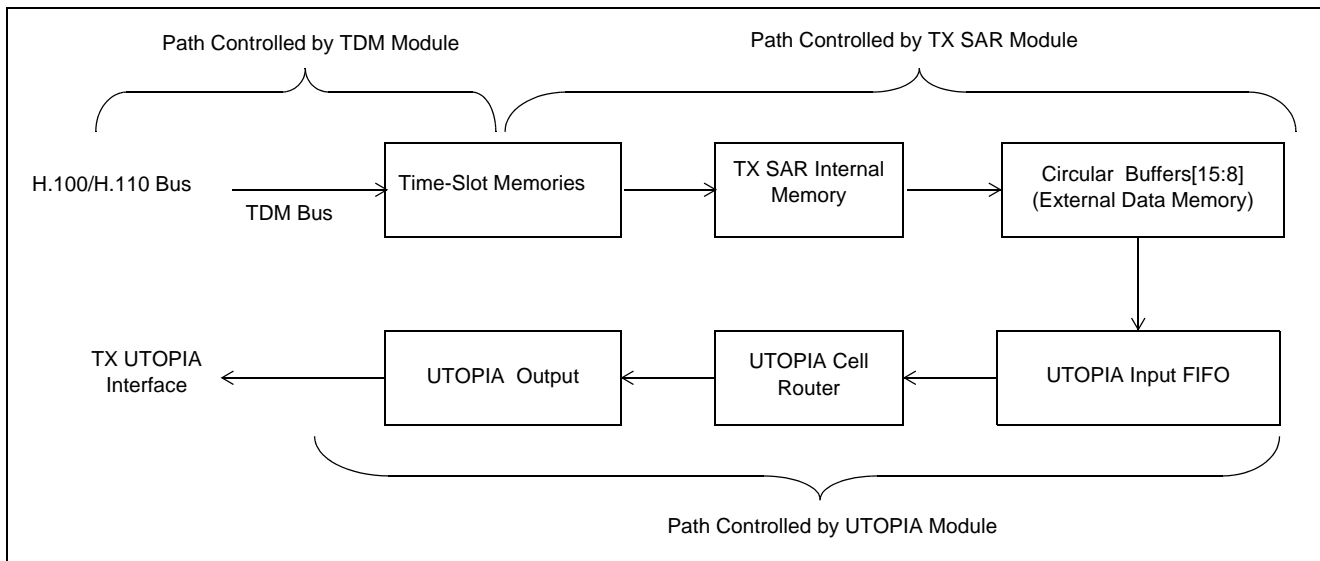

Figure 3 - Transmit Data Flow - TDM to UTOPIA

Figure 4 shows the dataflow from the RX UTOPIA interface to the H.100/H.110 bus.

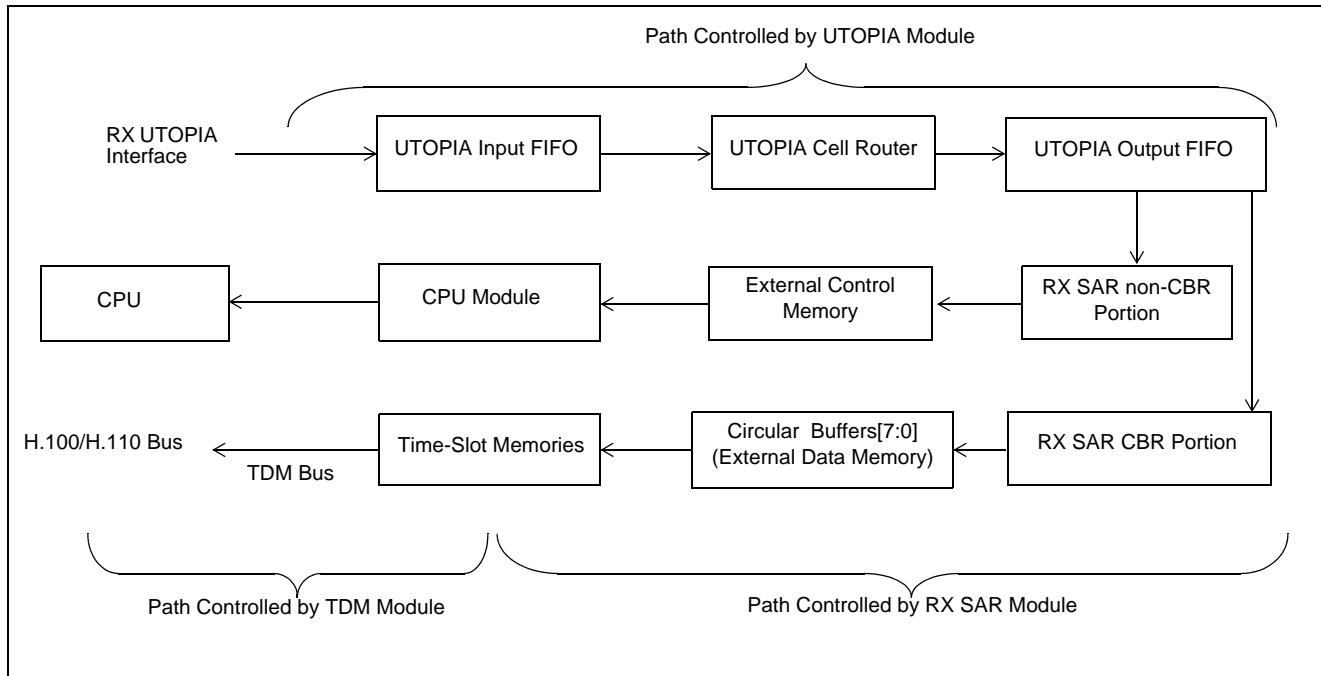

Figure 4 - Receive Data Flow - UTOPIA to TDM

2.0 Features Detailed Description

2.1 UTOPIA Interface

- Contains 3 UTOPIA ports with transmit and receive interfaces:
 - Port A: 16-bit or 8-bit UTOPIA Level 2, ATM mode (single-PHY) or PHY mode (single or multi-PHY). Accepts data rates up to 622 Mb/s.
 - Port B: 16-bit or 8-bit UTOPIA Level 2 without bus addressing, ATM mode or PHY mode (restricted to 8-bit when Port A is in multi-PHY mode). Accepts data rates up to 622 Mb/s.
 - Port C: 8-bit UTOPIA, ATM mode or PHY mode
- Supports cell switching through daisy chained SAR/PHY devices via the UTOPIA interface (AAL5 SARs, AAL1 SARs such as MT90503, and AAL2 SARs such as MT90502).
- Supports both UNI and NNI header formats
- Supports any combination of VCI/VPI concatenation up to 16 bits in ATM Receive direction
- Supports up to 65536 Virtual Circuits Per UTOPIA Port in ATM Receive direction
- Rapid timing reference cell processing in Receive/Segmentation direction
- Can eliminate null cells (VPI = 0, VCI = 0) received at UTOPIA A, B, and C port inputs
- Filters received cells before accessing VCC Look Up Table (LUT)
- UTOPIA VCC loopback for bi-directional ring functionality (from RX A to TX B and from RX B to TX A)
- Per-VCC User cell and OAM cell destination control (for VCs that have a LUT entry)
- Per-UTOPIA-port User cell and OAM cell destination control (for VCs that do not have a LUT entry)

2.2 TDM Interface

- H.100/H.110 compatible
- Low latency TDM bus to TDM bus loopback of up to 2048 channels
- Programmable value for the null-octet inserted during an underrun situation
- Receive buffer replay capability or silent pattern insertion for underrun situations
- Support of CAS and MFS for DS1(ESF) and E1
- Automatic Detection of a change in the CAS value, for CAS received in ATM cells, and CAS received from TDM bus

2.3 Clock Recovery

- SRTS clock recovery:
 - Dual reference VCs (for redundancy)
 - Broadcast SRTS VCs in Transmit /Segmentation direction
- Adaptive clock recovery
 - Dual reference VCs (for redundancy)
 - Limited jitter, precision enhanced, MCLK (chip clock) to 8 kHz dividers
- Direct 8 kHz clock recovery:
 - Can generate an 8 kHz reference using one of 8 multipurpose timing reference pins
 - Supports all $n * 8$ kHz input reference, (1.544 MHz, 2.048 MHz, 19.44 MHz, etc.) up to $12500 * 8$ kHz
 - Output high time and low time of the 8 kHz reference output can be modified relative to input signal
 - The eight multipurpose timing reference pins can be used to support many possible clock recovery configurations, including the following reference signals: SEC8K (MVIP), ATM8K (to/from PHY25 or from PHY155), FNXI (SRTS), CT_NETREF (for CT-Bus)
- Can generate a 20 MHz clock for an external PLL, e.g. MT9042 or MT9044 (output on one of the multipurpose timing reference pins)

2.4 ATM SAR

- Supports AAL1 (with pointer, or without pointer byte), CBR-AAL0, and CBR-AAL5 (AAL5-VTOA) Cell formats
- Supports partially filled cells, with fills from 4 to 47 bytes
- AAL1 cell format for "Structured DS1/E1 Nx64 Kbit/s Service" as per ATM Forum AF-VTOA-0078.000 "Circuit Emulation Services Interoperability Specification" (Nx64 Basic Service, DS1 Nx64 Service with CAS, and E1 Nx64 Service with CAS)
- VCs carrying 1 to 2048 TDM channels
- TDM to ATM Transmission latency less than 250 μ s (when minimum voice latency desired, and strict multiframe alignment of voice with CAS not required)
- TDM to ATM Transmission latency less than 3.25 ms (when strict multiframe alignment of voice with CAS required)
- ATM to TDM Reception latency less than $CDV + 250 \mu$ s (when minimum voice latency desired, and strict multiframe alignment of voice with CAS not required)
- ATM to TDM Reception latency less than $CDV + 6.250$ ms (when strict multiframe alignment of voice with CAS required)
- Per VCC monitoring (Receive/Reassembly direction):

-
- CDV Monitoring and Delay Correction Fields
 - Single cell loss, multiple cell loss, cell misinsertion, AAL1 parity, AAL1-CRC, P-byte Parity, P-Byte Out-of-Range error bits
 - Cell Arrival Counter
 - Underrun Slip Counter
 - Overrun Slip Counter
 - Per VCC monitoring (Transmit/Segmentation direction):
 - Cell Transmission Counter
 - Single received cell loss compensated, replacing the payload with a programmable null-octet
 - Support segmentation and reassembly of 2048 full duplex TDM channels (2048 without CAS, subtract one TDM channel for each CAS channel carried)
 - Support of up to ± 61 ms of CDV in non-multiframe mode, ± 45 ms in T1 with strict multiframing, ± 29 ms in E1 with strict multiframing
 - AAL0 Cell Generation / Reception for software implemented SAR function (cell buffer can contain up to 1024 cells)
 - Percentage of bandwidth usage register (Transmit/Segmentation direction)

2.5 Required External Components

- 128K/256K/512K x 18 Control Memory (can be used in up to 2 banks)
- Maximum addressable control memory: 1 MB
- 128K/256K/512K x 18 Data Memory (can be used in up to 4 banks)
- Maximum addressable data memory: 4 MB
- 8 kHz to 16/MHz PLL when H.100/H.110 interface used as master mode
- Clock driver for mclk_src

2.6 Particular Modes of Operation

- Test modes
 - TX SAR to RX SAR internal loop-back of some VCs, while MT90503 is running
 - TDM Bus loop-back

2.7 Miscellaneous

- Motorola/Intel CPU Interface (paged memory accesses)
- Programmable Maximum number of Interrupts per second
- Multipurpose I/Os
- LED pin generation for UTOPIA Interface
- Parity bits on memory and UTOPIA interfaces to ensure clocking and memory access integrity
- CPU-based OAM cell treatment
- JTAG (IEEE 1149) Test Access Port
- MCLK speed of 80 MHz
- Global reset pin with I/O tri-state

- Global power-down and tri-state

2.8 Power

- 3.3V core and I/O supply
- All I/Os are 3.3V with 5 V tolerance
- TDM pins are PCI 5V signalling tolerant (when PCI clamp rail tied to 5 V)

3.0 Pin Designations and Descriptions

The following tables identify each pin of the MT90503 device's main functional areas. A description of each pin is also provided.

Notes:

- 1 All outputs are +3.3 V_{DC}.
- 2 All input and output pins that are designated (F) can withstand 5 V_{DC} being applied to them.
- 3 All input and output pins that are designated (F) are tested with a 50 pF load unless otherwise specified.
- 4 Designations under the "rst" (reset condition) table column are: X = undefined; Z = high impedance; 1 = high (+3.3 V_{DC}).
- 5 I/O types include: Output (O), Input (I), Bidirectional (I/O), Power (PWR) and Ground (GND).
- 6 All buses have pins listed in order from MSB to LSB.

GND pins: A2, A4, A7, A8, A9, A12, A15, A18, A21, A22, A23, A25, A26, A28, B1, B29, D1, D26, D29, E1, E6, E29, G1, G29, H1, H29, J1, J29, L11, L13, L15, L17, L19, M1, M29, N11, N13, N15, N17, N19, R1, R11, R13, R17, R19, R29, T29, U11, U13, U15, U17, U19, V1, W11, W13, W15, W17, W19, AA1, AA29, AB1, AB29, AC1, AD5, AD25, AE1, AE13, AE29, AF1, AF29, AG29, AH1, AH2, AH28, AJ2, AJ4, AJ7, AJ8, AJ9, AJ12, AJ15, AJ18, AJ21, AJ22, AJ23, AJ25, AJ26, AJ28

VDD 3.3V pins: A3, A5, A10, A11, A14, A16, A19, A20, A27, A29, B2, C1, C29, K1, K29, L1, L29, P1, P29, T1, V29, W1, W29, Y1, Y29, AC29, AG1, AH3, AH29, AJ1, AJ3, AJ5, AJ10, AJ11, AJ14, AJ16, AJ19, AJ20, AJ27, AJ29

Pins not connected: A13, B3, B4, B7, B8, B9, B12, B13, B14, B15, B16, C3, C4, C7, C8, C9, C12, C13, C14, C15, D6, D7, D8, D9, D12, D13, D14, D15, D24, E5, E8, E9, E12, E13, E14, E15, E25, M5, M28, T25, W25, AB25, AE4, AE5, AE22, AE23, AE25, AF2, AF23

Pin	rst	Name	I/O	Type	Description
AE18, AF18, AG18, AH18, AE19, AF19, AG19, AH19, AF20, AG20, AH20, AE21, AF21, AG21, AH21	Z	inmo_a [14:0]	I	TTL (F)	Intel/Motorola interface address bus. Can be used as a GPI.
AE14, AF14, AG14, AH14, AG15, AH15, AE16, AF16	Z	inmo_d [7:0]	I/O	TTL, 4 mA (F)	Intel/Motorola interface data bus, low bits
AE12, AF12, AG12, AH12, AF13, AG13, AH13,AJ13	Z	inmo_d[15:8]	I/O	TTL, 4 mA (F)	Intel/Motorola interface data bus, high bits. Can be used as a GPIO if an 8 bit CPU Interface is used.
AF11		mclk_src	I	TTL (F)	Master Clock Source. An external clock that is multiplied to generate fast_clk.
AE11		$\overline{\text{reset}}$	I	Schmitt (F)	General Reset
AJ17	Z	inmo_a_das	I	TTL, 4 mA (F)	Direct Access Select. '1' selects the direct access space. '0' selects the indirection registers contained in the CPU interface. This pin can be connected to a[15] of an address bus but does not behave as an address pin.
AH17	Z	$\overline{\text{inmo_cs}}$	I	TTL, 4 mA (F)	Intel/Motorola interface chip select
AG17		inmo_ale	I	TTL (F)	Intel/Motorola interface address latch enable
AF17		inmo_w $\overline{\text{r}}$ _r/w	I	TTL (F)	Intel write or Motorola read/write
AH16		$\overline{\text{inmo_rd_ds}}$	I	TTL (F)	Intel read or Motorola data strobe
AG16	Z	inmo_rdy_ $\overline{\text{ndtack}}$	O	TTL, 8 mA (F)	Intel/Motorola interface ready/data acknowledge. This pin is active high for Intel (rdy) and active low for Motorola (ndtack).
AE20		cpu_mode[0]	I	TTL (F)	CPU Interface Mode Select Bit 0. The CPU Interface Mode Select bits must be hardwired.
AG22		cpu_mode[1]	I	TTL (F)	CPU Interface Mode Select Bit 1.
AH22		cpu_mode[2]	I	TTL (F)	CPU Interface Mode Select Bit 2.
AF22		cpu_mode[3]	I	TTL (F)	CPU Interface Mode Select Bit 3.
AH11	Z	interrupt1	O	4 mA (F)	frequency-controllable global interrupt
AG11	Z	interrupt2	O	4 mA (F)	instant global interrupt

Table 1 - CPU Bus Interface Pins

Pin	rst	Name	I/O	Type	Description
AG23, AH23, AE24, AF24, AG24, AH24, AJ24, AF25, AG25, AH25, AG26, AH26, AH27, AA26, AA27, AA28, W27, W28	X	cmem_a [17:0]	O	4 mA	Control memory address bus
W26	1	1. cmem_a[18] 2. cmem_cs [1]	1. O 2. O	4 mA	1. Control memory address bus 2. Control memory chip select 1.
AG28, AF27, AE26, AE28, AD27, AC26, AC28, AB27, AF28, AE27, AD26, AC25, AC27, AB26, AB28, AA25	Z	cmem_d[15:0]	I/O	TTL, 4 mA	Control memory data bus.
Y25	1	cmem_cs[0]	O	4 mA	Control memory chip select 0
Y27	X	cmem_bws[0]	O	4 mA	Control memory byte write select 0.
Y26	X	cmem_bws[1]	O	4 mA	Control memory byte write select 1.
Y28	X	cmem_r/w	O	4 mA	Control Memory R/W. This signal is only used for late write memories.
AG27, AF26	Z	cmem_par[1:0]	I/O	TTL, 4 mA	Control Memory Parity 1:0

Table 2 - Control Memory Bus Interface Pins

Pin	rst	Name	I/O	Type	Description
T28, K26, V28, U29, T27, T26, R28, K25, J27, J26, H28, H27, L25, H25, J28, G27, F25, F27, F29	X	dmem_a[18:0]	O	4 mA	Data memory address bus
P25, N28, N26, M27, L28, L26, K28, K27, P28, P26, N29, N27, N25, M26, L27, M25	Z	dmem_d[15:0]	I/O	TTL, 4 mA	Data memory data bus
U25	X	dmem_r/w	O	4 mA	Data Memory R/W. This signal is only used for late write memories.
U26	X	dmem_bws[0]	O	4 mA	Data memory byte write select 0.
U27	X	dmem_bws[1]	O	4 mA	Data memory byte write select 1.
U28	1	dmem_cs[0]	O	4 mA	Data memory chip select 0
V27	1	dmem_cs[1]	O	4 mA	Data memory chip select 1
V26	1	dmem_cs[2]	O	4 mA	Data memory chip select 2
V25	1	dmem_cs[3]	O	4 mA	Data memory chip select 3
R27	Z	dmem_par[0]	I/O	TTL, 4 mA	Data memory parity 0
P27	Z	dmem_par[1]	I/O	TTL, 4 mA	Data memory parity 1

Table 3 - Data Memory Bus Interface Pins

Pin	rst	Name	I/O	Type	Description
AD29		mem_clk_i	I	TTL	Data and Control memory clocks
AD28	X	mem_clk_o	O	4 mA	Data and Control memory clocks
R26		mem_clk_positive_i	I	PECL	Data and Control memory clocks, PECL
R25		mem_clk_negative_i	I	PECL	Data and Control memory clocks, PECL
AF15	X	mem_clk_positive_o	O	PECL	Data and Control memory clocks, PECL
AE15	X	mem_clk_negative_o	O	PECL	Data and Control memory clocks, PECL

Table 4 - Data and Control Memory Clock Pins

Pin	rst	Name	I/O	Type	Description
B17, A17, E22, D17, B19, B18, E16, C18, C16, C20, E18, E17, D16, E21, B22, B21, B20, B23, E19, C19, D23, D22, C22, D19, C24, B24, A24, E20, C21, B26, C23, D21	Z	ct_d[31:0]	I/O	PCI (F)	H.100/H.110 serial data bus
G25	Z	ct_netref1	I/O	Schmitt, 12 mA (F)	H.100/H.110 Network Reference 1.
G26	Z	ct_netref2	I/O	Schmitt, 12 mA (F)	H.100/H.110 Network Reference 2.
C28	Z	ct_c8_a	I/O	Schmitt, 12 mA (F)	H.100/H.110 8 MHz clock A
B28	Z	ct_c8_b	I/O	Schmitt, 12 mA (F)	H.100/H.110 8 MHz clock B
C27	Z	ct_frame_a	I/O	Schmitt, 12 MA (F)	H.100/H.110 Frame pulse A
C26	Z	ct_frame_b	I/O	Schmitt, 12 MA (F)	H.100/H.110 Frame pulse B
E26	Z	ct_fr_comp	O	12 mA (F)	H.100/H.110 compatibility frame pulse
D27	Z	ct_c2	O	12 mA (F)	MVIP 90-bit clock
D28	Z	ct_c4	O	12 mA (F)	MVIP 90-bit clock times two
E23	Z	ct_c16-	O	12 mA (F)	H-MVIP 16 MHz clock
D25	Z	ct_c16+	O	12 mA (F)	H-MVIP 16 MHz clock
E27	Z	ct_sclk	O	12 mA (F)	SCBUS system clock
E28	Z	ct_sclx2	O	12 mA (F)	SCBUS system clock times two
F26		ct_mc	I/O	TTL, 12 mA (F)	H.100/H.110 Message Channel. Open Collector output.
E24	X	mc_clock	O	4 mA (F)	H.100/H.110 Message Channel extracted clock. 2 MHz. Nominal duty cycle: 62% high, 38% low.
B27		mc_tx	I	TTL (F)	H.100/H.110 Message channel transmit data. When this signal is '0', the MT90503 will drive ct_mc low. When '1', the MT90503 will not drive ct_mc.
C25	X	mc_rx	O	4 mA (F)	H.100/H.110 Message channel receive data. The level of this pin directly reflects the value of ct_mc.

Table 5 - H.100/H.110 Bus Interface Pins

Pin	rst	Name	I/O	Type	Description
B25		ct_vdd5_0	I		5V power supply used in PCI Buffers of the ct_d[31:0] signals. Can also be connected to 3V power supply.
D20		ct_vdd5_1	I		See ct_vdd5_0.
D18		ct_vdd5_2	I		See ct_vdd5_0.
C17		ct_vdd5_3	I		See ct_vdd5_0.

Table 5 - H.100/H.110 Bus Interface Pins (continued)

Pin	rst	Name	I/O	Type	Description
E10	Z	recov_a	I/O	TTL, 4 mA (F)	Clock recovery general I/O A. This pin can be used as a GPIO.
D10	Z	recov_b	I/O	TTL, 4 mA (F)	Clock recovery general I/O B. This pin can be used as a GPIO.
C10	Z	recov_c	I/O	TTL, 4 mA (F)	Clock recovery general I/O C. This pin can be used as a GPIO.
B10	Z	recov_d	I/O	TTL, 4 mA (F)	Clock recovery general I/O D. This pin can be used as a GPIO.
E11	Z	recov_e	I/O	TTL, 4 mA (F)	Clock recovery general I/O E. This pin can be used as a GPIO.
D11	Z	recov_f	I/O	TTL, 4 mA (F)	Clock recovery general I/O F. This pin can be used as a GPIO.
C11	Z	recov_g	I/O	TTL, 4 mA (F)	Clock recovery general I/O G. This pin can be used as a GPIO.
B11	Z	recov_h	I/O	TTL, 4 mA (F)	Clock recovery general I/O H. This pin can be used as a GPIO.

Table 6 - Clock Recovery Pins

Pin	Nom Switch (MHz)	rst	Name	I/O	Type	Description
AE17	0		global_tri_state	I	TTL (F)	(PU) Should be 1 for functional mode, 0 for tristate.
AH5	1		tck	I	TTL (F)	JTAG Test Clock. Should be 1 when not in use
AG5	1		tdi	I	TTL (F)	JTAG Test Data In. Should be 1 when not in use
AH4	1	X	tdo	O	TTL, 4 mA (F)	JTAG Test Data Out
AG4	1		tms	I	TTL (F)	JTAG Test Mode Select. Should be 1 when not in use.
AE7	1		trst	I	TTL (F)	JTAG Test Reset. Should be 0 when not in use.

Table 7 - Test Pins

Pin	rst	Name	I/O	Type	Description
H3	Z	txa_clk	I/O	TTL, 4 mA (F)	UTOPIA Port A TX Clock
C6	Z	rx_a_clk	I/O	TTL, 4 mA (F)	UTOPIA Port A RX Clock
C2		phy_a_alm	I	TTL (F)	PHY alarm A This pin can also act as a GPI.
D2	Z	phy_a_rx_led	I/O	TTL, 12 mA (F)	LED signal. When the LED is on, this pin will be '0'. When the LED is off, this pin will be tri-state. This pin can also act as a GPIO.
H5	Z	phy_a_tx_led	I/O	TTL, 12 mA (F)	LED signal. When LED is on, this pin will be '0'. When the LED is off, this pin will be tri-state. This pin can also act as a GPIO.
J5		1. txa_clav 2. txa_enb	1.I 2.I	TTL (F)	1. UTOPIA Port A TX Cell Available (in ATM) 2. UTOPIA Port A TX Enable (in PHY)
H2	1.Z 2.Z	1. $\overline{\text{txa_enb}}$ 2. txa_clav	1.O 2.O	4 mA (F)	1. UTOPIA Port A TX Enable (in ATM). This pin must be pulled-up externally. 2. UTOPIA Port A TX Cell Available (in PHY). This pin must be pulled-down externally.
N2	Z	txa_soc	O	4 mA (F)	UTOPIA Port A TX Start of Cell
L5, K2, K3, K4, K5, J2, J3, J4	Z	txa_data[7:0]	O	4 mA (F)	UTOPIA Port A TX Data bus
N4, N5, M2, M3, M4, L2, L3, L4	Z	txa_data[15:8]	I/O	TTL, 4 mA (F)	UTOPIA Port A TX Data bus Each of these pins can be used as a GPIO.
N3	Z	txa_par	O	4 mA (F)	UTOPIA Port A TX Parity
A6		1. rx_a_clav 2. rx_a_enb	1.I 2.I	TTL (F)	1. UTOPIA Port A RX Cell Available (in ATM) 2. UTOPIA Port A RX Enable (in PHY)
B6	1. Z 2. Z	1. $\overline{\text{rx_a_enb}}$ 2. rx_a_clav	1.O 2.O	4 mA (F)	1. UTOPIA Port A RX Enable (in ATM). This pin must be pulled-up externally. 2. UTOPIA Port A RX Cell Available (in PHY). This pin must be pulled-down externally.
H4		rx_a_soc	I	TTL (F)	UTOPIA Port A RX Start of Cell
E2, E3, E4, D3, D4, D5, C5, B5		rx_a_data[7:0]	I	TTL (F)	UTOPIA Port A RX Data bus
G3, G4, G5, F1, F2, F3, F4, F5		rx_a_data[15:8]	I	TTL (F)	UTOPIA Port A RX Data bus Each of these pins can be used as a GPI.
G2		rx_a_par	I	TTL (F)	UTOPIA Port A RX Parity
W4	Z	txb_clk	I/O	TTL, 4 mA	UTOPIA Port B TX Clock
N1	Z	rx_b_clk	I/O	TTL, 4 mA (F)	UTOPIA Port B RX Clock
AB5		phy_b_alm	I	TTL (F)	PHY alarm B This pin can also act as a GPI.
W5	Z	phy_b_rx_led	I/O	TTL, 12 mA (F)	LED signal. When LED is on, this pin will be '0'. When the LED is off, this pin will be tri-state. This pin can also act as a GPIO.

Table 8 - UTOPIA Interface Pins

Pin	rst	Name	I/O	Type	Description
T5	Z	phyb_tx_led	I/O	TTL, 12 mA (F)	LED signal. When LED is on, this pin will be '0'. When the LED is off, this pin will be tri-state. This pin can also act as a GPIO.
W2		1. <u>txb_clav</u> 2. <u>txb_enb</u>	1.I 2.I	TTL (F)	1. UTOPIA Port B TX Cell Available (in ATM) 2. UTOPIA Port B TX Enable (in PHY)
W3	1Z 2Z	1. <u>txb_enb</u> 2. <u>txb_clav</u>	1.O 2.O	4 mA (F)	1. UTOPIA Port B TX Enable (in ATM) This pin must be pulled-up externally. 2. UTOPIA Port B TX Cell Available (in PHY). This pin must be pulled-down externally.
AD2	Z	txb_soc	O	4 mA (F)	UTOPIA Port B TX Start of Cell
AA2, AA3, AA4, AA5, Y2, Y3, Y4, Y5	Z	txb_data[7:0]	O	4 mA (F)	UTOPIA Port B TX Data bus
AC3, AC4, AG2, AB2, AB3, AB4	Z	txb_data[13:8]	I/O	TTL, 4 mA (F)	UTOPIA Port B TX Data bus Each of these pins can be used as a GPIO.
AC2	Z	1. <u>txb_data</u> [14] 2. <u>rx_a_addr</u> [4]	1.O 2.I	TTL, 4 mA (F)	1. UTOPIA Port B TX Data bus 2. UTOPIA Port A RX Address 4 This pins can be used as a GPIO.
AD4	Z	1. <u>txb_data</u> [15] 2. <u>tx_a_addr</u> [4]	1.O 2.I	TTL, 4 mA (F)	1. UTOPIA Port B TX Data bus 2. UTOPIA Port A TX Address 4 This pin can be used as a GPIO.
AD3	Z	txb_par	O	4 mA (F)	UTOPIA Port B TX Parity
P4		1. <u>rx_b_clav</u> 2. <u>rx_b_enb</u>	1.I 2.I	TTL (F)	1. UTOPIA Port B RX Cell Available (in ATM) 2. UTOPIA Port B RX Enable (in PHY)
P5	1.Z 2.Z	1. <u>rx_b_enb</u> 2. <u>rx_b_clav</u>	1.O 2.O	4 mA (F)	1. UTOPIA Port B RX Enable (in ATM). This pin must be pulled-up externally. 2. UTOPIA Port B RX Cell Available (in PHY). This pin must be pulled-down externally.
V2		rx_b_soc	I	TTL (F)	UTOPIA Port B RX Start of Cell
T3, T4, R2, R3, R4, R5, P2, P3		rx_b_data [7:0]	I	TTL (F)	UTOPIA Port B RX Data bus
U3, U4, U5, T2		1. <u>rx_b_data</u> [11:8] 2. <u>rx_a_addr</u> [3:0]	1.I 2.I	TTL (F)	1.UTOPIA Port B RX Data bus 2. UTOPIA Port A RX Address bus
V4, V5, U1, U2		1. <u>rx_b_data</u> [15:12] 2. <u>tx_a_addr</u> [3:0]	1.I 2.I	TTL (F)	1. UTOPIA Port B RX Data bus 2. UTOPIA Port A TX Address bus
V3		rx_b_par	I	TTL (F)	UTOPIA Port B RX Parity
AG10	Z	txc_clk	I/O	TTL, 4 mA (F)	UTOPIA Port C TX Clock
AF7	Z	rx_c_clk	I/O	TTL, 4 mA (F)	UTOPIA Port C RX Clock
AE10		1. <u>txc_clav</u> 2. <u>txc_enb</u>	1.I 2.I	TTL (F)	1. UTOPIA Port C TX Cell Available (in ATM). 2. UTOPIA Port C TX Enable (in PHY).

Table 8 - UTOPIA Interface Pins (continued)

Pin	rst	Name	I/O	Type	Description
AF10	1. Z 2. Z	1. $\overline{\text{txc_enb}}$ 2. $\overline{\text{txc_clav}}$	1.O 2.O	4 mA (F)	1. UTOPIA Port C TX Enable (in ATM). This pin must be pulled-up externally. 2. UTOPIA Port C TX Cell Available (in PHY). This pin must be pulled-down externally.
AH9	Z	txc_soc	O	4 mA (F)	UTOPIA Port C TX Start of Cell
AG9, AF9, AE9, AH8, AG8, AF8, AE8, AH7	Z	txc_data[7:0]	O	4 mA (F)	UTOPIA Port C TX Data bus
AG7	Z	txc_par	O	4 mA (F)	UTOPIA Port C TX Parity
AH6		1. $\overline{\text{rx_clav}}$ 2. $\overline{\text{rx_enb}}$	1.I 2.I	TTL (F)	1. UTOPIA Port C RX Cell Available (in ATM) 2. UTOPIA Port C RX Enable (in PHY)
AJ6	1. Z 2. Z	1. $\overline{\text{rx_enb}}$ 2. $\overline{\text{rx_clav}}$	1.O 2.O	4 mA (F)	1. UTOPIA Port C RX Enable (in ATM). This pin must be pulled-up externally. 2. UTOPIA Port C RX Cell Available (in PHY). This pin must be pulled-down externally.
AG6	1.Z	rx_soc	I	TTL (F)	UTOPIA Port C RX Start of Cell
AF6, AE6, AF5, AF4, AE2, AE3, AF3, AD1		rx_data[7:0]	I	TTL (F)	UTOPIA Port C RX Data bus
AH10		rx_par	I	TTL (F)	UTOPIA Port C RX Parity

Table 8 - UTOPIA Interface Pins (continued)

Pin	rst	Name	I/O	Type	Description
J25		pllvs_110	I		VSS pin for the CT PLL. See Figure 5, "PLL Pin Connections," on page 34 for recommended connections.
F28		pllvd_110	I		VDD pin for the CT PLL. See Figure 5, "PLL Pin Connections," on page 34 for recommended connections.
H26		pllfp2_110	I		Loop-filter pin for the CT PLL. See Figure 5, "PLL Pin Connections," on page 34 for recommended connections.
G28		pllag_110	O		Analog Ground pin for the CT PLL. See Figure 5, "PLL Pin Connections," on page 34 for recommended connections.
AC5		pllvs_300	I		VSS pin for the FC PLL. See Figure 5, "PLL Pin Connections," on page 34 for recommended connections.
AG3		pllvd_300	I		VDD pin for the FC PLL. See Figure 5, "PLL Pin Connections," on page 34 for recommended connections.

Table 9 - Phase Lock Loop (PLL) Pins

Pin	rst	Name	I/O	Type	Description
E7		proc_out	O		Process Monitor Pin Output. Must not be connected.

Table 10 - Process Monitor Pins

Pin	Location	Pin	Location	Pin	Location	Pin	Location
A2	GND	B9	N/C	C16	ct_d[23]	D23	ct_d[11]
A3	VDD	B10	recov_d	C17	ct_vdd5_3	D24	N/C
A4	GND	B11	recov_h	C18	ct_d[24]	D25	ct_c16+
A5	VDD	B12	N/C	C19	ct_d[12]	D26	GND
A6	1. rxa_clav 2. rxa_enb	B13	N/C	C20	ct_d[22]	D27	ct_c2
A7	GND	B14	N/C	C21	ct_d[3]	D28	ct_c4
A8	GND	B15	N/C	C22	ct_d[9]	D29	GND
A9	GND	B16	N/C	C23	ct_d[1]	E1	GND
A10	VDD	B17	ct_d[31]	C24	ct_d[7]	E2	rx_data[7]
A11	VDD	B18	ct_d[26]	C25	mc_rx	E3	rx_data[6]
A12	GND	B19	ct_d[27]	C26	ct_frame_b	E4	rx_data[5]
A13	N/C	B20	ct_d[15]	C27	ct_frame_a	E5	N/C
A14	VDD	B21	ct_d[16]	C28	ct_c8_a	E6	GND
A15	GND	B22	ct_d[17]	C29	VDD	E7	proc_out
A16	VDD	B23	ct_d[14]	D1	GND	E8	N/C
A17	ct_d[30]	B24	ct_d[6]	D2	phy_rx_led	E9	N/C
A18	GND	B25	ct_vdd5_0	D3	rx_data[4]	E10	recov_a
A19	VDD	B26	ct_d[2]	D4	rx_data[3]	E11	recov_e
A20	VDD	B27	mc_tx	D5	rx_data[2]	E12	N/C
A21	GND	B28	ct_c8_b	D6	N/C	E13	N/C
A22	GND	B29	GND	D7	N/C	E14	N/C
A23	GND	C1	VDD	D8	N/C	E15	N/C
A24	ct_d[5]	C2	phy_alm	D9	N/C	E16	ct_d[25]
A25	GND	C3	N/C	D10	recov_b	E17	ct_d[20]
A26	GND	C4	N/C	D11	recov_f	E18	ct_d[21]
A27	VDD	C5	rx_data[1]	D12	N/C	E19	ct_d[13]
A28	GND	C6	rx_clk	D13	N/C	E20	ct_d[4]
A29	VDD	C7	N/C	D14	N/C	E21	ct_d[18]

Table 11 - Pin Names Listed by Location

Pin	Location	Pin	Location	Pin	Location	Pin	Location
B1	GND	C8	N/C	D15	N/C	E22	ct_d[29]
B2	VDD	C9	N/C	D16	ct_d[19]	E23	ct_c16-
B3	N/C	C10	recov_c	D17	ct_d[28]	E24	mc_clock
B4	N/C	C11	recov_g	D18	ct_vdd5_2	E25	N/C
B5	rx_data[0]	C12	N/C	D19	ct_d[8]	E26	ct_fr_comp
B6	1. rxa_enb 2. rxa_clav	C13	N/C	D20	ct_vdd5_1	E27	ct_sclk
B7	N/C	C14	N/C	D21	ct_d[0]	E28	ct_sclkx2
B8	N/C	C15	N/C	D22	ct_d[10]	E29	GND
F1	rx_data[12]	J3	tx_data[1]	L29	VDD	P26	dmem_d[6]
F2	rx_data[11]	J4	tx_data[0]	M1	GND	P27	dmem_par[1]
F3	rx_data[10]	J5	1. tx_clav 2. tx_enb	M2	tx_data[13]	P28	dmem_d[7]
F4	rx_data[9]	J25	pll_vss_110	M3	tx_data[12]	P29	VDD
F5	rx_data[8]	J26	dmem_a[9]	M4	tx_data[11]	R1	GND
F25	dmem_a[2]	J27	dmem_a[10]	M5	N/C	R2	rx_data[5]
F26	ct_mc	J28	dmem_a[4]	M25	dmem_d[0]	R3	rx_data[4]
F27	dmem_a[1]	J29	GND	M26	dmem_d[2]	R4	rx_data[3]
F28	pll_vdd_110	K1	VDD	M27	dmem_d[12]	R5	rx_data[2]
F29	dmem_a[0]	K2	tx_data[6]	M28	N/C	R11	GND
G1	GND	K3	tx_data[5]	M29	GND	R13	GND
G2	rx_data[15]	K4	tx_data[4]	N1	rx_data[1]	R17	GND
G3	rx_data[15]	K5	tx_data[3]	N2	tx_data[1]	R19	GND
G4	rx_data[14]	K25	dmem_a[11]	N3	tx_data[1]	R25	mem_clk_negative_i
G5	rx_data[13]	K26	dmem_a[17]	N4	tx_data[15]	R26	mem_clk_positive_i
G25	ct_netref1	K27	dmem_d[8]	N5	tx_data[14]	R27	dmem_par[0]
G26	ct_netref2	K28	dmem_d[9]	N11	GND	R28	dmem_a[12]
G27	dmem_a[3]	K29	VDD	N13	GND	R29	GND
G28	pllagn_110	L1	VDD	N15	GND	T1	VDD
G29	GND	L2	tx_data[10]	N17	GND	T2	1. rx_data[8] 2. rx_addr[0]
H1	GND	L3	tx_data[9]	N19	GND	T3	rx_data[7]
H2	1. tx_enb 2. tx_clav	L4	tx_data[8]	N25	dmem_d[3]	T4	rx_data[6]
H3	tx_data[1]	L5	tx_data[7]	N26	dmem_d[13]	T5	phyb_tx_led

Table 11 - Pin Names Listed by Location (continued)

Pin	Location	Pin	Location	Pin	Location	Pin	Location
H4	rxa_soc	L11	GND	N27	dmem_d[4]	T25	N/C
H5	phya_tx_led	L13	GND	N28	dmem_d[14]	T26	dmem_a[13]
H25	dmem_a[5]	L15	GND	N29	dmem_d[5]	T27	dmem_a[14]
H26	Plllp2_110	L17	GND	P1	VDD	T28	dmem_a[18]
H27	dmem_a[7]	L19	GND	P2	rxb_data[1]	T29	GND
H28	dmem_a[8]	L25	dmem_a[6]	P3	rxb_data[0]	U1	1. rxb_data[13] 2. txa_addr[1]
H29	GND	L26	dmem_d[10]	P4	1. rxb_clav 2. rxb_enb	U2	1. rxb_data[12] 2. txa_addr[0]
J1	GND	L27	dmem_d[1]	P5	1. rxb_enb 2. rxb_clav	U3	1. rxb_data[11] 2. rxa_addr[3]
J2	txa_data[2]	L28	dmem_d[11]	P25	dmem_d[15]	U4	1. rxb_data[10] 2. rxa_addr[2]
U5	1. rxb_data[9] 2. rxa_addr[1]	W26	1. cmem_a[18] 2. cmem_cs[1]	AB28	cmem_d[1]	AE11	reset
U11	GND	W27	cmem_a[1]	AB29	GND	AE12	inmo_d[15]
U13	GND	W28	cmem_a[0]	AC1	GND	AE13	GND
U15	GND	W29	VDD	AC2	1. txb_data[14] 2. rxa_addr[4]	AE14	inmo_d[7]
U17	GND	Y1	VDD	AC3	txb_data[13]	AE15	mem_clk_negative_o
U19	GND	Y2	txb_data[3]	AC4	txb_data[12]	AE16	inmo_d[1]
U25	dmem_r/w	Y3	txb_data[2]	AC5	pllvs_300	AE17	global_tri_state
U26	dmem_bws[0]	Y4	txb_data[1]	AC25	cmem_d[4]	AE18	inmo_a[14]
U27	dmem_bws[1]	Y5	txb_data[0]	AC26	cmem_d[10]	AE19	inmo_a[10]
U28	dmem_cs[0]	Y25	cmem_cs[0]	AC27	cmem_d[3]	AE20	cpu_mode[0]
U29	dmem_a[15]	Y26	cmem_bws[1]	AC28	cmem_d[9]	AE21	inmo_a[3]
V1	GND	Y27	cmem_bws[0]	AC29	VDD	AE22	N/C
V2	rxb_soc	Y28	cmem_r/w	AD1	rx_data[0]	AE23	N/C
V3	rxb_par	Y29	VDD	AD2	txb_soc	AE24	cmem_a[15]
V4	1. rxb_data[15] 2. txa_addr[3]	AA1	GND	AD3	txb_par	AE25	N/C
V5	1. rxb_data[14] 2. txa_addr[2]	AA2	txb_data[7]	AD4	1. txb_data[15] 2. txa_addr[4]	AE26	cmem_d[13]
V25	dmem_cs[3]	AA3	txb_data[6]	AD5	GND	AE27	cmem_d[6]
V26	dmem_cs[2]	AA4	txb_data[5]	AD25	GND	AE28	cmem_d[12]
V27	dmem_cs[1]	AA5	txb_data[4]	AD26	cmem_d[5]	AE29	GND

Table 11 - Pin Names Listed by Location (continued)

Pin	Location	Pin	Location	Pin	Location	Pin	Location
V28	dmem_a[16]	AA25	cmem_d[0]	AD27	cmem_d[11]	AF1	GND
V29	VDD	AA26	cmem_a[4]	AD28	mem_clk_o	AF2	N/C
W1	VDD	AA27	cmem_a[3]	AD29	mem_clk_i	AF3	rx_data[1]
W2	1. txb_clav 2. txb_enb	AA28	cmem_a[2]	AE1	GND	AF4	rx_data[4]
W3	1. txb_enb 2. txb_clav	AA29	GND	AE2	rx_data[3]	AF5	rx_data[5]
W4	txb_clk	AB1	GND	AE3	rx_data[2]	AF6	rx_data[7]
W5	phyb_rx_led	AB2	txb_data[10]	AE4	N/C	AF7	rx_clk
W11	GND	AB3	txb_data[9]	AE5	N/C	AF8	txc_data[2]
W13	GND	AB4	txb_data[8]	AE6	rx_data[6]	AF9	txc_data[6]
W15	GND	AB5	phyb_alm	AE7	trst	AF10	1. txc_enb 2. txc_clav
W17	GND	AB25	N/C	AE8	txc_data[1]	AF11	mclk_src
W19	GND	AB26	cmem_d[2]	AE9	txc_data[5]	AF12	inmo_d[14]
W25	N/C	AB27	cmem_d[8]	AE10	1. txc_clav 2. txc_enb	AF13	inmo_d[11]
AF14	inmo_d[6]	AG11	interrupt2	AH8	txc_data[4]	AJ5	VDD
AF15	mem_clk_positive_o	AG12	inmo_d[13]	AH9	txc_soc	AJ6	1. rxc_enb 2. rxc_clav
AF16	inmo_d[0]	AG13	inmo_d[10]	AH10	rx_data[par]	AJ7	GND
AF17	inmo_wr_rw	AG14	inmo_d[5]	AH11	interrupt1	AJ8	GND
AF18	inmo_a[13]	AG15	inmo_d[3]	AH12	inmo_d[12]	AJ9	GND
AF19	inmo_a[9]	AG16	inmo_rdy_ndtack	AH13	inmo_d[9]	AJ10	VDD
AF20	inmo_a[6]	AG17	inmo_ale	AH14	inmo_d[4]	AJ11	VDD
AF21	inmo_a[2]	AG18	inmo_a[12]	AH15	inmo_d[2]	AJ12	GND
AF22	cpu_mode[3]	AG19	inmo_a[8]	AH16	inmo_rd_ds	AJ13	inmo_d[8]
AF23	N/C	AG20	inmo_a[5]	AH17	inmo_cs	AJ14	VDD
AF24	cmem_a[14]	AG21	inmo_a[1]	AH18	inmo_a[11]	AJ15	GND
AF25	cmem_a[10]	AG22	cpu_mode[1]	AH19	inmo_a[7]	AJ16	VDD
AF26	cmem_par[0]	AG23	cmem_a[17]	AH20	inmo_a[4]	AJ17	inmo_a_das
AF27	cmem_d[14]	AG24	cmem_a[13]	AH21	inmo_a[0]	AJ18	GND
AF28	cmem_d[7]	AG25	cmem_a[9]	AH22	cpu_mode[2]	AJ19	VDD
AF29	GND	AG26	cmem_a[7]	AH23	cmem_a[16]	AJ20	VDD
AG1	VDD	AG27	cmem_par[1]	AH24	cmem_a[12]	AJ21	GND

Table 11 - Pin Names Listed by Location (continued)

Pin	Location	Pin	Location	Pin	Location	Pin	Location
AG2	txb_data[11]	AG28	cmem_d[15]	AH25	cmem_a[8]	AJ22	GND
AG3	pllvd_300	AG29	GND	AH26	cmem_a[6]	AJ23	GND
AG4	tms	AH1	GND	AH27	cmem_a[5]	AJ24	cmem_a[11]
AG5	tdi	AH2	GND	AH28	GND	AJ25	GND
AG6	rxs_soc	AH3	VDD	AH29	VDD	AJ26	GND
AG7	txc_par	AH4	tdo	AJ1	VDD	AJ27	VDD
AG8	txc_data[3]	AH5	tck	AJ2	GND	AJ28	GND
AG9	txc_data[7]	AH6	1. rxc_clav 2. rxc_enb	AJ3	VDD	AJ29	VDD
AG10	txc_clk	AH7	txc_data[0]	AJ4	GND		

Table 11 - Pin Names Listed by Location (continued)

Type	Input	Output	I/O	Power	Ground	N/C	Total
UTOPIA Port A	21	12	12				45
UTOPIA Port B	21	14	10				45
UTOPIA Port C	12	12	2				26
Clock recovery	0	0	8				8
CPU Bus	26	3	16				45
TDM Bus (H.100/H.110 bus)	1	9	39	4			53
Control memory	0	23	18				41
Data memory	0	26	18				44
Data and Control Memory Clocks	3	3	0				6
Test	6	0	0				6
PLL	1	1	0	2	2		6
Power				40			40
Ground					88		88
Miscellaneous		1					1
No Connects						49	49
Total:	91	104	123	46	90	49	503

Table 12 - Pinout Summary

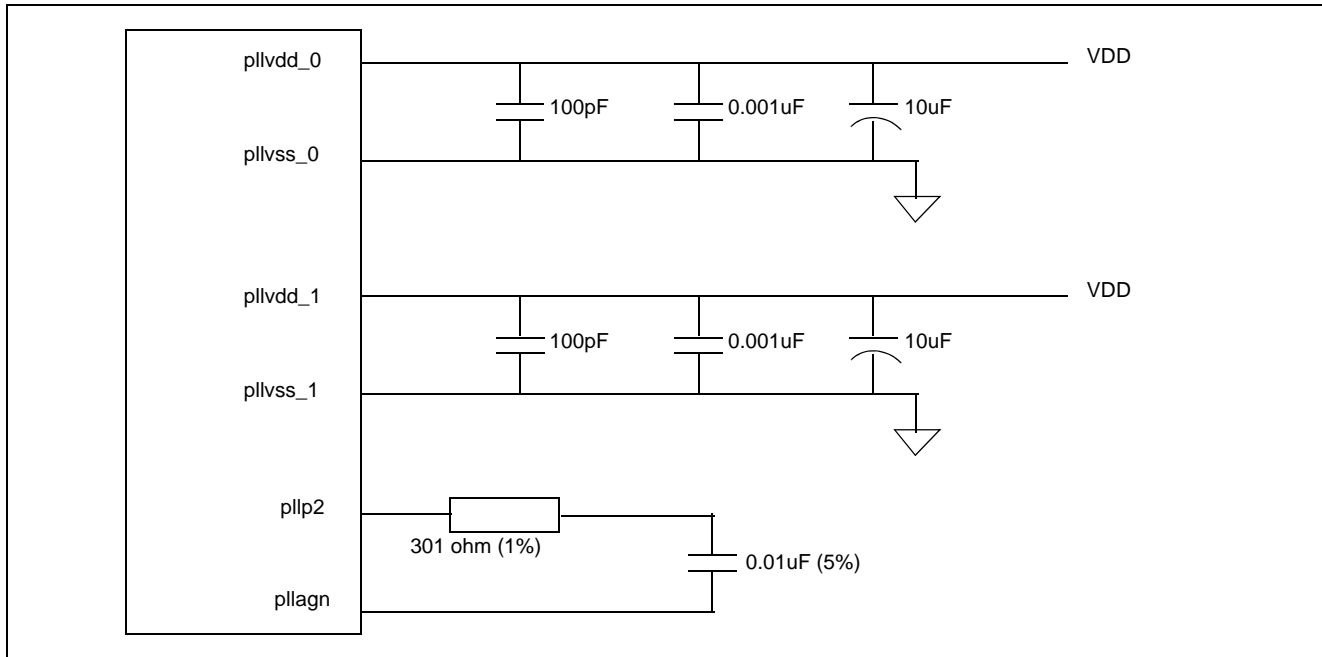

Figure 5 - PLL Pin Connections

4.0 Functional Description¹

4.1 CPU Interface

The MT90503 CPU module provides an interface permitting programmability from an external microprocessor. The CPU module permits read/write access from MT90503: internal registers, internal and external memories.

The CPU interface comprises of:

- Direct Access Select (DAS) as the MSB bit concatenated with a 15-bit address bus
- 16-bit data bus
- 2 interrupt signals
- associated control signals
- little endian format, unless otherwise specified

The CPU interface can be configured to operate with either Intel or Motorola CPUs. The MT90503 supports both 8-bit or 16-bit data bus and multiplexed or non-multiplexed address/data pins. If the CPU is operating in 15-bit byte mode addressing with the LSB of its address bus as a byte field, then the inmo_a [14:0] pins of the MT90503 can be connected to the a[15:1] pins of the CPU. If both the MT90503 and the CPU are in 15-bit word mode addressing, then the inmo_a[14:0] pins should be connected to the a[14:0] pins of the CPU.

A reduced set of registers 'CPU Interface Registers' (0000h to 000Ah) are employed to optimize access time and to permit the CPU to execute indirect read/write accesses via these registers. The CPU also engages these registers to perform direct read/write accesses. The MT90503 and CPU timing relationship is described in section 9.1 on page 211.

The CPU Control Register (0100h) provides a software reset capability that allows the CPU to reset the MT90503 except for the CPU interface. The CPU interface can only be reset by a hardware reset.

1. This product incorporates technology licensed from Melita International Corporation.

4.1.1 CPU Interrupts

The CPU interface provides a programmable global interrupt capability. The interrupt signal names are 'interrupt1' and 'interrupt2', pins AH11 and AG11 respectively. Both interrupts have programmability to select their polarity (open collector drive) via registers 'interrupt1_conf' and 'interrupt2_conf' addresses 0224h and 0226h respectively. Interrupt1 accommodates a capability to program a minimum acceptable period between interrupts. The period is programmed in μ s units via 'interrupt1_conf' register. This provides a 'frequency interrupt controller' facility and masks the assertion of further interrupts until the specified period has elapsed. The mask period will commence when the interrupt1_treated[15], register interrupt_flags address 0220h is set. When Interrupt2 is enabled it is always activated when an interrupt condition occurs. Interrupt pins are always tri-stated when inactive.

The operation of the CPU interrupt network is common for all modules. When an interrupt is asserted an interrupt flag is set to identify the module where the interrupt was generated. Each module has one or more Interrupt Enable Status Registers where a set interrupt enable bit identifies the source of the interrupt. On completion of the ISR the interrupt must be cleared as the interrupt will remain asserted until it is de-asserted by the user. All Interrupt Enable Status Registers have a symmetrical Status Register. Hence, the bit positioning of the interrupt enables and the associated status bits are identical.

4.1.1.1 Example Interrupt Flow

Upon the initialization of the Global Interrupt pins the following methodology is adopted to identify the source of the interrupt. For this example Interrupt2 is employed and the CPU module will be the source of the interrupt.

4.1.1.2 Interrupt Initialization

- Set interrupt polarity, register interrupt2_conf[15:14].
- Enable Interrupt2 for the CPU module, register interrupt2_enable[0] 022Ch. The MT90503 will generate an interrupt on interrupt2 according to the modules enabled in interrupt2_enable.
- Set the individual CPU interrupt sources by enabling the respective bits in the 'status0_ie' 0104h register. Within the 'status0_ie' register there are two possible interrupt sources: internal_read_timeout_ie and inmo_read_done_ie. In the MT90503 Register Description the interrupt bits are labelled IE (Interrupt Enable) in the 'Type' column. This register offers the facility to mask/disable unwanted interrupts.

4.1.1.3 Interrupt Servicing

When interrupt2 is asserted ('interrupt2' pin):

- Read the interrupt flags to ascertain the module raising the interrupt. The CPU module interrupt flag is located in register interrupt_flags[0] 0220h, this bit is named cpureg_interrupt_active.
- If the cpureg_interrupt_active bit is set, locate the source of the CPU interrupt by reading the 'status0' register 0102h, either internal_read_timeout and/or inmo_read_done.
- The associated status register 'status0' 0102h contains internal_read_timeout and inmo_read_done bits. Therefore, to de-assert the interrupt the user must write a 1 to register 0102h bits 3 or 4, internal_read_timeout and inmo_read_done respectively. Only then will the interrupt be de-asserted.

4.1.2 Intel/Motorola Interface

The MT90503 CPU interface supports both Intel and Motorola microprocessors, in both 8-bit or 16-bit data bus and multiplexed or non-multiplexed address/data pins. The MT90503 supports 8 MB of addressable space, therefore indirection addressing is necessary. The microprocessor interface directly addresses five control words, used for indirection accessing. The indirection register contents are shown in tables 13 to 17 inclusively. The timing relationship pertaining to the CPU Interface Registers and Extended Access is defined in section 9.1 on page 211.

0000h	Control Register
0004h	Read/Write Data Register
0008h	Address High Register
000Ah	Address Low Register

cpu_mode [3:0]	Interface Type	address pins	data pins	direct_access	ale
0000	Intel, 16 bit data bus, non-multiplexed	inmo_a[14:0]** (word address)	inmo_d[15:0]	inmo_a_das	inmo_ale*
0001	Intel, 16 bit data bus, multiplexed	inmo_d[15:1] (word address)	inmo_d[15:0]	inmo_a_das	inmo_ale*
0010	Intel, 8 bit data bus, non-multiplexed	inmo_a[14:0] (byte address)	inmo_d[7:0]	inmo_a_das	inmo_ale*
0011	Intel, 8 bit data bus, multiplexed	inmo_a[14:8]& inmo_d[7:0] (byte address)	inmo_d[7:0]	inmo_a_das	inmo_ale*
0100	Motorola, 16 bit data bus, non-multiplexed	inmo_a[14:0] (word address)	inmo_d[15:0]	inmo_a_das	inmo_ale*
0101	Motorola, 16 bit data bus, multiplexed	inmo_d[15:1] (word address)	inmo_d[15:0]	inmo_a_das	inmo_ale*
0110	Motorola, 8 bit data bus, non-multiplexed	inmo_a[14:0] (byte address)	inmo_d[7:0]	inmo_a_das	inmo_ale*
0111	Motorola, 8 bit data bus, multiplexed	inmo_a[14:8]& inmo_d[7:0] (byte address)	inmo_d[7:0]	inmo_a_das	inmo_ale*
1xxx	Reserved				

* The inmo_ale pin is interpreted in all modes. However, it is not necessary in the non-multiplexed modes and can be tied to VCC.
 **The address placed on the inmo_a[14:0] pins is a word address in 16-bit mode and a byte address in 8-bit mode. The address, when placed on the inmo_d pins, is always a byte address.

Table 13 - CPU Interface Mode Selection

Field	Bit	Type	Reset	Description														
read_burst_length	6:0	RW	01h	Number of words to prefetch. <table style="margin-left: 20px;"> <tr> <td>Setting</td> <td>Words</td> </tr> <tr> <td>00h</td> <td>128</td> </tr> <tr> <td>01h</td> <td>1</td> </tr> <tr> <td>02h</td> <td>2</td> </tr> <tr> <td>.</td> <td>.</td> </tr> <tr> <td>.</td> <td>.</td> </tr> <tr> <td>7Fh</td> <td>127</td> </tr> </table> <p>This field is set to 01h for individual (non-sequential) reads. All burst reads greater than 256-bytes must be executed in two or more burst reads.</p>	Setting	Words	00h	128	01h	1	02h	2	7Fh	127
Setting	Words																	
00h	128																	
01h	1																	
02h	2																	
.	.																	
.	.																	
7Fh	127																	
reserved	7	RO	0h	Reset to 0.														
access_req	8	PC	0h	Set by software when an extended access is initialised. Reset by hardware when the access is completed. Used for extended indirect access only.														
extended_a[3:1]	11:9	RW	0h	Extended address bits 3:1. Invalid for extended direct access.														
write_enable	13:12	RW	0h	Active high write enables. 00 = read access. 01 = write to lower byte. 10 = write to upper byte. 11 = write to entire word. This field is ignored for: extended direct reads and all byte wide extended direct accesses.														
extended_parity	15:14	RW	0h	Read/Write Parity bits.														

Table 14 - Control Register (0000h)

Field	Bit	Type	Reset	Description
extended_data[15:0]	15:0	RW	0000h	The extended indirect read/write data word register. Invalid for extended direct access.

Table 15 - Read/Write Data Register (0004h)

Field	Bit	Type	Reset	Description
extended_a[32:20]	12:0	RW	000h	Upper extended address [32:20].
Reserved	15:13	RO	0h	Reset to 000.

Table 16 - Address High Register (0008h)

Field	Bit	Type	Reset	Description
extended_a[19:4]	15:0	RW	0000h	Lower extended address [19:4]. In extended direct addressing, bits 19:16 are employed for 16 bit data bus and bits 19:15 are employed for 8 bit data bus.

Table 17 - Address Low Register (000Ah)

4.1.2.1 Extended Indirect Accessing

Extended Indirect Accessing solely employs the registers 0000h to 000Ah to access the 8 MB of addressable memory space.

Synopsis: the user writes the access address to registers 0000h, 0008h and 000Ah. Then the MT90503 will read/write to that address and fetch/place the data value from/to register 0004h. For all extended indirect accesses the INMO_A_DAS bit will be held low.

4.1.2.2 Extended Indirect Writes

The following steps must be executed to perform an extended indirect write:

- 1 Write the upper address, `extended_a[32:20]`, to register 0008h. This write may be not be required if previous value holds true.
- 2 Write the lower address, `extended_a[19:4]`, to register 000Ah. This write may be not be required if previous value holds true.
- 3 Write the write data, `extended_data[15:0]`, to register 0004h. This write may be not be required if previous value holds true.
- 4 Write `write_enable`, `extended_parity`, `access_req='1'` and `extended_a [3:1]` in a single access to register 0000h.
- 5 Read the `access_req` bit located in the Control Register[8] to determine when the write has completed.

The software will set `access_req [8]` in register 0000h (Step 4 above) and the hardware will reset it when the data write has completed. Therefore, the user can poll this bit to determine when the data write has completed.

4.1.2.3 Extended Indirect Reads

- 1 Write the upper address, `extended_a[32:20]`, to register 0008h. This write may be not be required if previous value holds true.
- 2 Write the lower address, `extended_a[19:4]`, to register 000Ah. This write may be not be required if previous value holds true.
- 3 Write `write_enable = 00`, `access_req='1'` and `extended_a [3:1]` in a single access to register 0000h.
- 4 Wait until `access_req` is cleared, then read the data from the data field `extended_data[15:0]`, register 0004h.
- 5 Optional parity check may be ascertained by performing a read on the `extended_parity[15:14]`, register 0000h.

The software will set `access_req[8]` register 0000h and the hardware will reset it when the data is ready to be read from register 0004h.

4.1.2.4 Extended Direct Accessing

Extended Direct Accessing employs the high and low address registers to perform page addressing. The address within the page is provided directly by the CPU address bus. Similarly the data is fetched/placed directly on the CPU data bus.

Synopsis: the user writes the access address to registers 0008h and 000Ah but this performs only the page addressing. Upon assertion of the address within the page the MT90503 will read/write the data with respect to that address. The INMO_A_DAS bit is set when the data read/write occurs. When operating the CPU interface in direct mode with a 16-bit data bus, `extended_a[19:16]`, are employed for the lower address word register 000Ah.

However, when operating the CPU interface in direct mode with an 8-bit data bus bits, [19:15] are used for the lower address word.

4.1.2.5 Extended Direct Writes

- 1 Write the upper address, extended_a[32:20], to register 0008h. This write may be not be required if previous value holds true.
- 2 Write the lower address extended_a[19:16] or [19:15] to register 000Ah. The remaining bits [15:4] or [14:4] are ignored. This write may be not be required if previous value holds true.
- 3 Write write_enable[13:12] (where applicable) and extended_parity[15:14]. The extended parity write is optional.
- 4 Write the data value to the address within the corresponding memory page with the INMO_A_DAS bit set.

4.1.2.6 Extended Direct Reads

- 1 Write the upper address, extended_a[32:20], to register 0008h. This write may be not be required if previous value holds true.
- 2 Write the lower address, extended_a[19:16] or [19:15], to register 000Ah. The remaining bits [15:4] or [14:4] are ignored. This write may be not be required if previous value holds true.
- 3 Assert the lower address within the memory page and fetch the read data with INMO_A_DAS set.
- 4 An optional read may be performed to obtain the parity values, extended_parity[15:14] register 0000h.

4.1.3 MT90503 Reset Procedure

The following reset procedure is required to power-up the MT90503. The reset procedure must be adhered at power-up employing the reset pin. Post power-up, the reset procedure can be performed from step 3.

- 1 Assert the reset pin for at least 1000 MCLK cycles.
- 2 De-assert the reset pin. All accesses in the remaining reset procedure will employ indirection.
- 3 Initialise the mem_clk_* bits and write_cache_enable bit via the Control Register bits [13:10], address 0100h.
- 4 Write the mclk_src frequency at register led1[6:0] and LED Flash Frequency at registers led1[15:7], register address 0120h. Write the LED Flash Frequency units (i.e. ms or μ s) at register led2[0], address 0122h.
- 5 Initialise the PLL via register pll_conf, address 0128h.
- 6 Set bits nreset_* in the Control Register bits [7:0], address 0100h.
- 7 Initialize the data and control memory types via registers 0240h, 0242h, 0244h, 0248h, 024Ah, and 024Ch
- 8 Select UTOPIA clocking methodology at register addresses 0230h, 0232h, 0234h and 0236h.
- 9 Configure the interrupts' active_level for interrupt1 and interrupt2 in register 0224h and 0226h.

4.2 TDM Module

The general architecture of the TDM bus consists of three main elements.

- The TDM bus interface which is coupled directly to the bus pins and manages the timing requirements of the H.100/H.110 interface.
- The datapath management for transporting the bytes from the TDM bus to the circular buffers (located in the external data memory).
- The TDM clocking mechanism, this enables the MT90503 to be H.100/H.110 bus master capable and communicates with the clock recovery module.

4.2.1 TDM Bus Interface

The MT90503 TDM Module interfaces with all 32 data streams of the H.100/H.110 bus. The maximum data rate of 8.192 Mbps determines the total bus capacity of 4096 TDM TSST. The MT90503 can process up to: 2048 transmitting TDM TSST and 2048 receiving TDM TSST within one frame of 125 μ s.

One less TDM channel is carried for each CAS channel that is desired. If all TDM channels have CAS, then 1024 transmit and 1024 receive channels is the limit. The MT90503 can drive out data on any particular TSST (Time Slot/Stream), or read in data from any particular TSST.

Each individual time slot or DS0 on the H.1x0 bus is assigned by a unique TSST number, based on the following equation:

$$\text{TSST} = \begin{cases} \text{timeslot} * 32 + \text{stream} & \text{for 8MHz streams} \\ (\text{timeslot} * 2+1) * 32 + \text{stream} & \text{for 4MHz streams} \\ (\text{timeslot} * 4+3) * 32 + \text{stream} & \text{for 2MHz streams} \end{cases}$$

The timeslot ranges from 0 to 31 for 2MHz streams, from 0 to 63 for 4MHz streams, or from 0 to 127 for 8MHz streams.

The 16 lowest data streams are capable of running at a data rate lower than 8.192 MHz. The streams are grouped in fours and each quartet must run at the same data rate. Streams [3:0], [7:4], [11:8] and [15:12] can each run at 2.048, 4.096 or 8.192 MHz as a group. This allows backward compatibility with older, slower TDM buses. In the reduced rate, the data is still latched using the CT_C8_A or _B clock-edge, but using every second or every fourth clock-edge. The streams numbered [31:16] must always run at 8.192 MHz.

The TDM bus can also be configured to use only 4, 8, or 16 streams. This configuration requires less processing of TDM bytes and, also allows a reduced mclk speed. The 4-stream mode is useful for conducting tests, while the 16-stream mode allows mclk speed to be cut in half while still allowing half the bandwidth of a full H.100/H.110 bus.

When the H.100/H.110 bus is carrying CAS signalling bits, every even stream carries regular TDM data bytes, and is associated with an odd stream that carries CAS bits and the indication of the beginning of the multiframe. For TSSTs that are input to the MT90503, the multiframing is provided by the framer. For TSSTs that are generated by the MT90503, the output multiframing is provided by the MT90503; there is one multiframe which is common to all the T1 channel signals and one multiframe which is common to all the E1 channel signals. On the input, the multiframing is independent for each TSST and the MT90503 synchronises all of them to its multiframe.

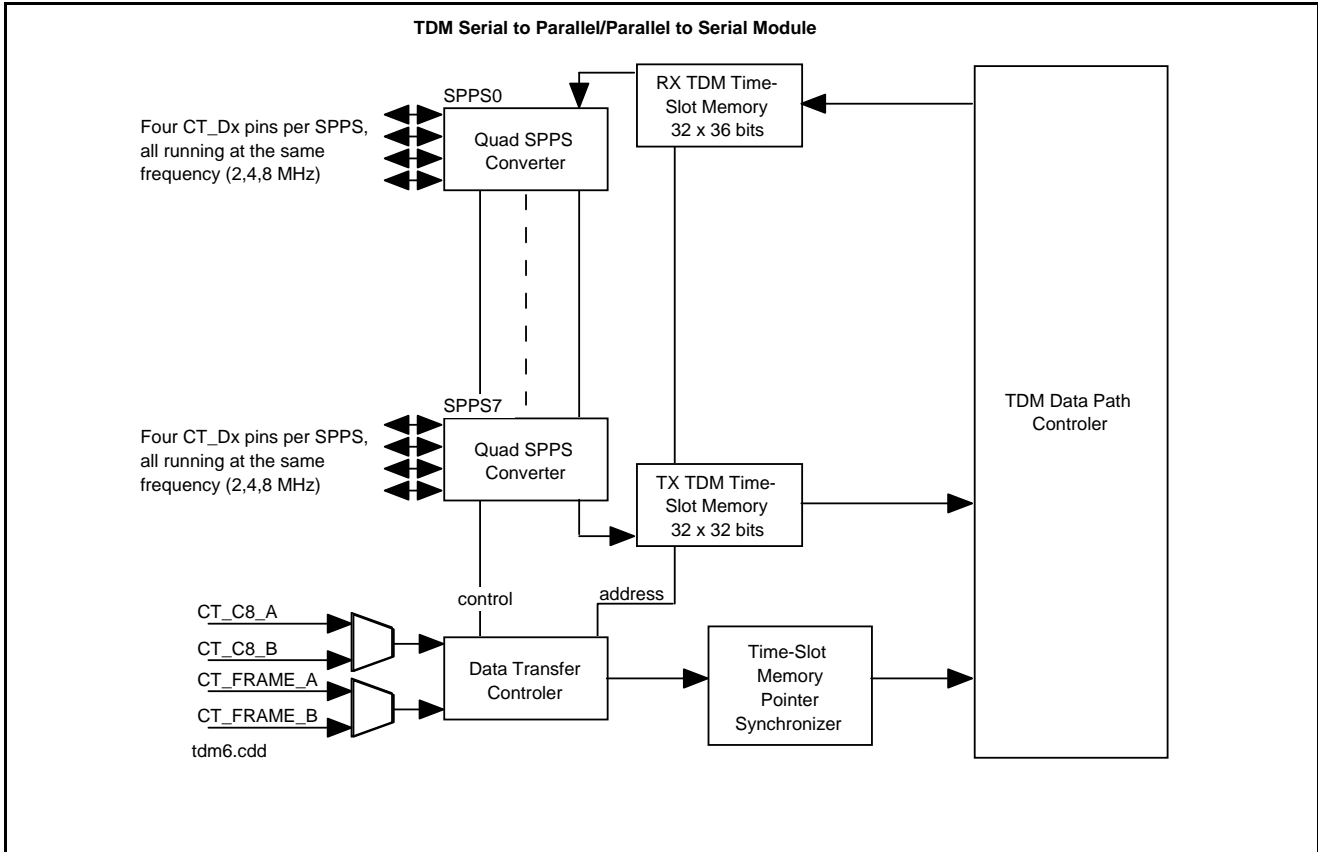

Figure 6 - TDM Serial to Parallel/Parallel to Serial (SPPS) Converter

Each TSST can be used independently for CAS or regular TDM bytes. For example, if time slot 0 on stream 0 requires signalling bits, then they will be carried on time slot 0, stream 1. However, time slot 1 stream 1 can be used to carry normal TDM data, even if the time slot preceding it is used for signalling. T1 and E1 channel formats can be supported simultaneously. The multiframe bit's polarity and position is programmable and global, and will be accepted at both the input and output. The CAS bits occupy bits [7:4] or [3:0] of the CAS byte, depending on the position within the byte of the multiframe indicator. The only difference between CAS support in E1 or T1 mode is the number of frames in the multiframe. T1 contains 24 frames within its multiframes while E1 contains 16. The CAS bits are latched at the input when the multiframe bit is active, and sent out on the output side during the entire multiframe. When the multiframe bit is at an active polarity, the associated TDM byte is the first byte of the multiframe.

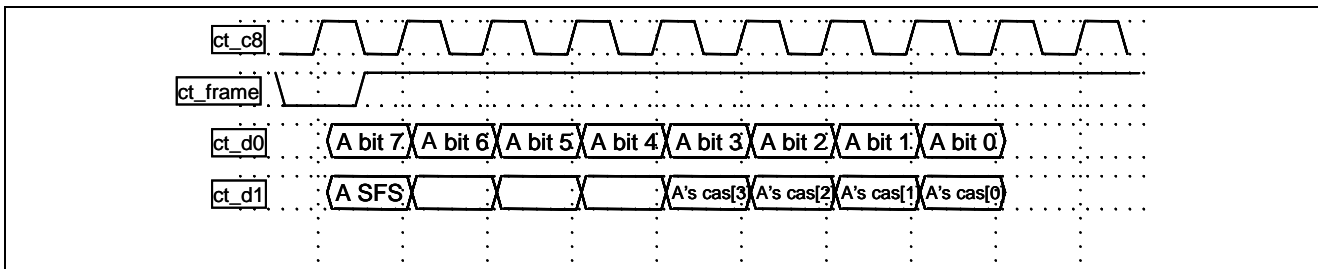

Figure 7 - CAS and MFS Transport on the TDM Bus

Figure 7, CAS and MFS Transport on the TDM Bus shows the direct interface of the MT90503 with the TDM bus.

The TDM interface is capable of looping back up to 2048 TSSTs with a latency of two TDM frames, or 250 μ s. This loopback is indicated by the control structures associated to each TSST. The loopback allows any two time-slots and streams to be connected together, and work independently of the speed of each of the streams.

The MT90503 can interface with 32 data streams as mentioned in previous paragraphs. Since each TSST can be used to either send or receive data, the MT90503 must tri-state the CT_D pins that are receiving data. To avoid overlap between a sending and a receiving TSST, this must be done before the next one begins.

4.2.2 TDM Bus Clocking Mechanism

The MT90503 can operate as either a primary or secondary H.100/H.110 master clock source. The H.100/H.110 clock (CT_C8) is driven by either CT_C8_A or CT_C8_B. The MT90503 can generate the primary bus clock and all its associated bus clocks (ct_fr_comp, sclk, sclkx2, CT_C16-, CT_C16+, CT_C2 and CT_C4) by using the CT_NETREF signal. The CT_NETREF may be received from another H.100/H.110 bus compatible device or it can be determined by the clock recovery module. In master mode, the MT90503 will generate all the compatibility clocks that are necessary for communicating with MVIP and SCSA TDM interfaces. These include the FR_COMP, C2, C4 and C16 signals for communicating with MVIP buses, and the SCLK and SCLKx2 signals for communicating with Signal Computing System Architecture SCSA buses.

The TDM module monitors both CT_C8_A and CT_C8_B signals for clock properties and failure. In every operating mode, both the CT_C8_A and CT_C8_B signals are monitored for clock failure. There are two methods of detecting a clock failure on the bus. Firstly, if the rising edge of the clock does not appear within ± 35 ns window of the expected period, the clock is flagged as being invalid. Secondly, if a single frame does not contain exactly 1024 clock cycles, then the clock will fail.

The MT90503 can be configured to switch to the backup master clock (CT_C8_A or CT_C8_B), upon the detection of a master clock failure. The MT90503 can be programmed as a secondary master and therefore switch to the backup master clock when the external primary master clock source has failed. If the MT90503 switches from a secondary master to master it will re-synchronise the TDM module with the backup clock and generate the compatibility clocks. The MT90503 continually monitors both CT_C8_A and CT_C8_B clocks for a failure condition. The MT90503 can be programmed to automatically switch to its backup clock in case of a failure.

The MT90503 is an H.100/H.110 master-capable device and, therefore, is able to generate both CT_C8 clocks and CT_FRAME and compatibility signals. As long as the primary signals on the bus are valid, the MT90503 will synchronise its output to them using a PLL. The MT90503 can also generate the CT_C8 and CT_FRAME signals independently of the PLL, using the local 16 MHz clock. In this case, the output signals have no phase relation with those present on the bus.

When the TDM bus interface module has written the received data to the circular buffers, it increments the Time-Slot Memory Pointer that is sent to the TX_SAR.

4.2.3 TDM Datapath

When writing to the external data memory, no return value is expected. However, when reading data, a return value, upon storing the data into an RX TSST, is expected and is required to be written back to the structure memory. The underrun count, which may or may not have been updated, is always written back along with all the other bits of the second word.

When the data is received at the time slot memory, it is sent via the TDM datapath to the external data memory. According to which time slot is currently being used, the TDM control structures are read.

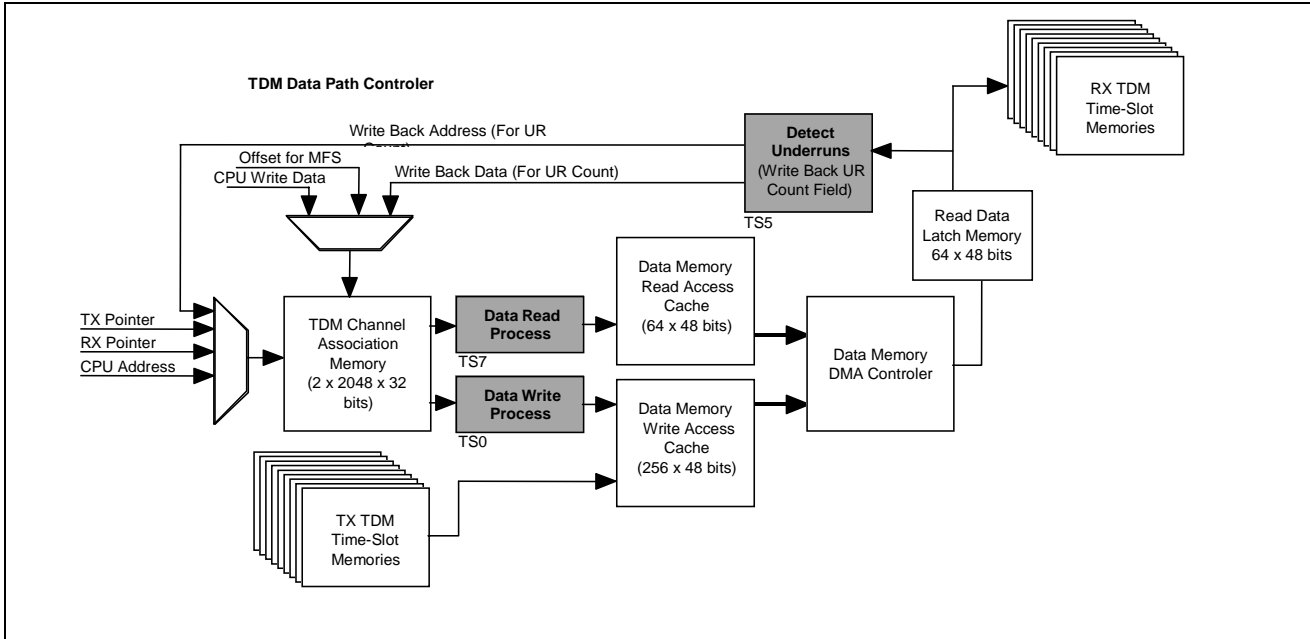

Figure 8 - TDM Data Path Controller

When accesses are performed from the TDM channel association memory, the write back to the RX half of the circular buffer is also performed. When this write back is done, the underrun detection bit is written to '0', and a null-octet is inserted in place of the old data byte.

The TDM datapath module can be configured to work with 32 H.100/H.110 streams, 16-streams, 8-streams, or 4-streams in order to allow lower clock speeds on the MT90503. The bandwidth requirements for supporting each of the above configurations are described in the Bandwidth section.

4.2.4 TDM Channel Association Structures

TDM channel association structures are located at 0x8000 to 0xBFFE in internal memory. Each structure corresponds to a TDM channel by its TSST order.

4.2.4.1 Non CAS Operation

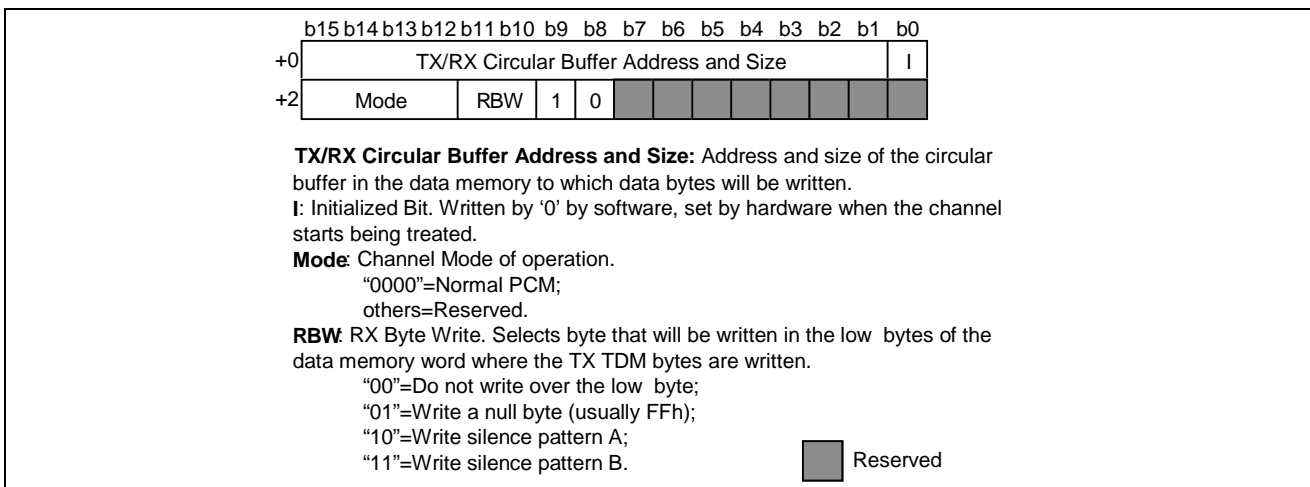

Figure 9 - TDM Channel Association Structures: TX Channel non-CAS mode

The control structure in Figure 10, TDM Channel Association: RX Channels (Non CAS mode) on page 44 indicates the mode and options selected for the TDM channel. In the general TX structure, the RBW (RX Byte Write) bits provide the format of the byte that is to be written over the RX byte in the circular buffer. While it is possible to write over the low-byte, there are three possibilities provided if writing over the byte is chosen: writing a null byte or generating one of two silence patterns. The detailed description of the dual-direction buffer is provided in the TDM Circular Buffers section.

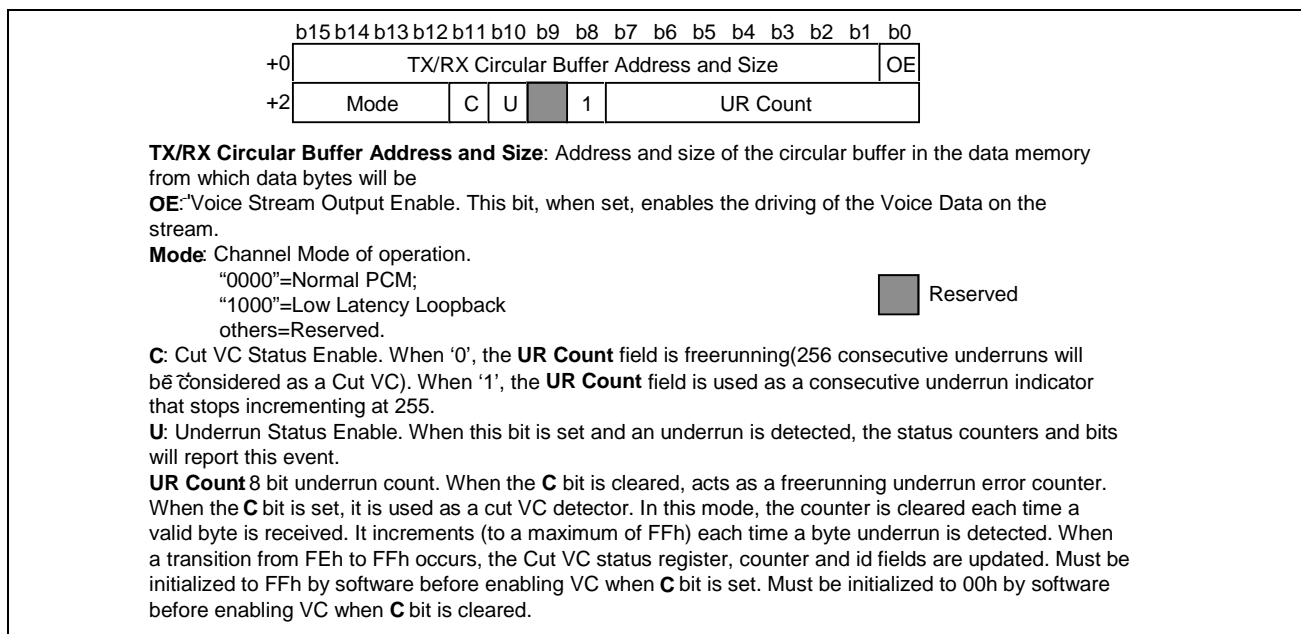

Figure 10 - TDM Channel Association: RX Channels (Non CAS mode)

In the receive direction, the control structure retains some of the recurrent features from the transmit structure. The TX circular buffer/size field is the same, which is normal given that the TX and RX circular buffers are common. The information on the address and size is encoded in the same way as in the TX structure.

For the reception structure, the high mode bit codes whether the RX channel is transmitting a channel received from ATM or if it is retransmitting information taken from the TDM bus and written into a circular buffer. If the high Mode bit is '0', the channel is ATM; if it is '1', the channel is TDM. By supporting a low latency TDM loopback, the MT90503 conforms to the H.100/H.110 specification.

The C and U bits serve as status enable bits. These bits are R/W, and tell the register module whether the register counters and status bits should report errors on this VC. The U bit is the underrun status enable: when this bit is set and an underrun is detected, the TDM register module will increment the global underrun counter and set the underrun detect status bit.

The C bit serves at the cut VC detect status enable. When this bit is at '0', the UR count acts as a free running 256-underrun counter. In this case, it serves to compile the total number of underruns that have occurred. When the C bit is at '1', then the UR count serves as a detector for cut VCs. The counter resets to 0 each time a valid TDM byte is received. If an underrun is received, the counter is incremented by one. If the counter ever increments from 254 to 255, then 255 consecutive underruns have been received, indicating there is 32 ms of absent data. This is interpreted as a cut VC and will generate an interrupt.

Cell-loss integration periods of greater than 32 ms can be supported by software. Upon UR Count reaching 255, and subsequent interrupt to the CPU, the software can check that the count has not returned to zero (which happens if the cells start to arrive again) at some interval equivalent to the cell-loss integration period.

4.2.4.2 CAS Operation

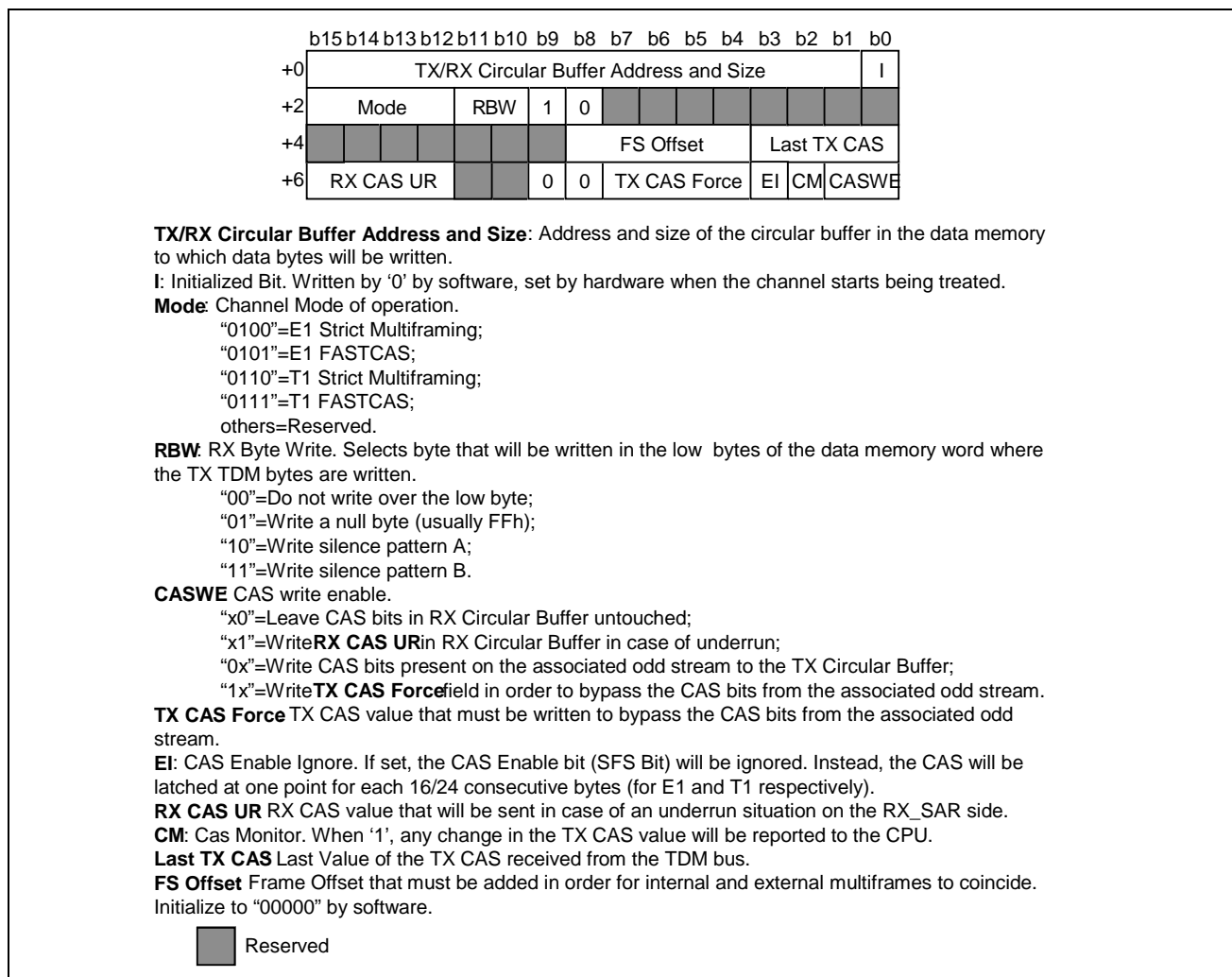

Figure 11 - TDM Channel Association: TX Channels (CAS mode)

The RX Byte Write bits remain the same to allow the insertion of null patterns as for regular channels. The Mode bits, indicate the possible configurations and combinations of multiframeing and CAS insertion: "0100" is E1, "0110" is T1, and toggling the lowest bit of either of the numbers indicates that the FASTCAS method of transmitting the data and CAS bytes is being used. FASTCAS is used to lower the latency of Circuit Emulation cells. When using the FASTCAS mode, the multiframe pointer is not used and multiframe integrity is therefore not maintained.

In addition, special fields for CAS are added in the two additional words of the structure. The CAS WE (CAS Write Enable) bits are used to determine if the CAS is written back.

The TX_CAS field is used so the CPU can insert values of CAS, in place of values from the TDM bus; the RX CAS value is used to compensate for underruns.

The Last TX CAS field is used to detect when the CAS value received on the TDM bus has changed. When a CAS value is received, it is written back to the Last TX CAS field in the structure. Whenever a new value arrives, it is compared to the last value. If there is a difference, a CAS change signal is sent to the registers, and the new CAS value is written to the CAS change buffer in the external memory.

The Frame Offset field is used to store the offset between the internal and external multiframe in the TX direction. When the TDM bus first obtains an external multiframe, it writes the offset field to the correct value between 0 and

23. Subsequently, each time that a byte is written to the circular buffer, the offset field is read, and an offset is established between the internal TDM pointer and the pointer that will be used.

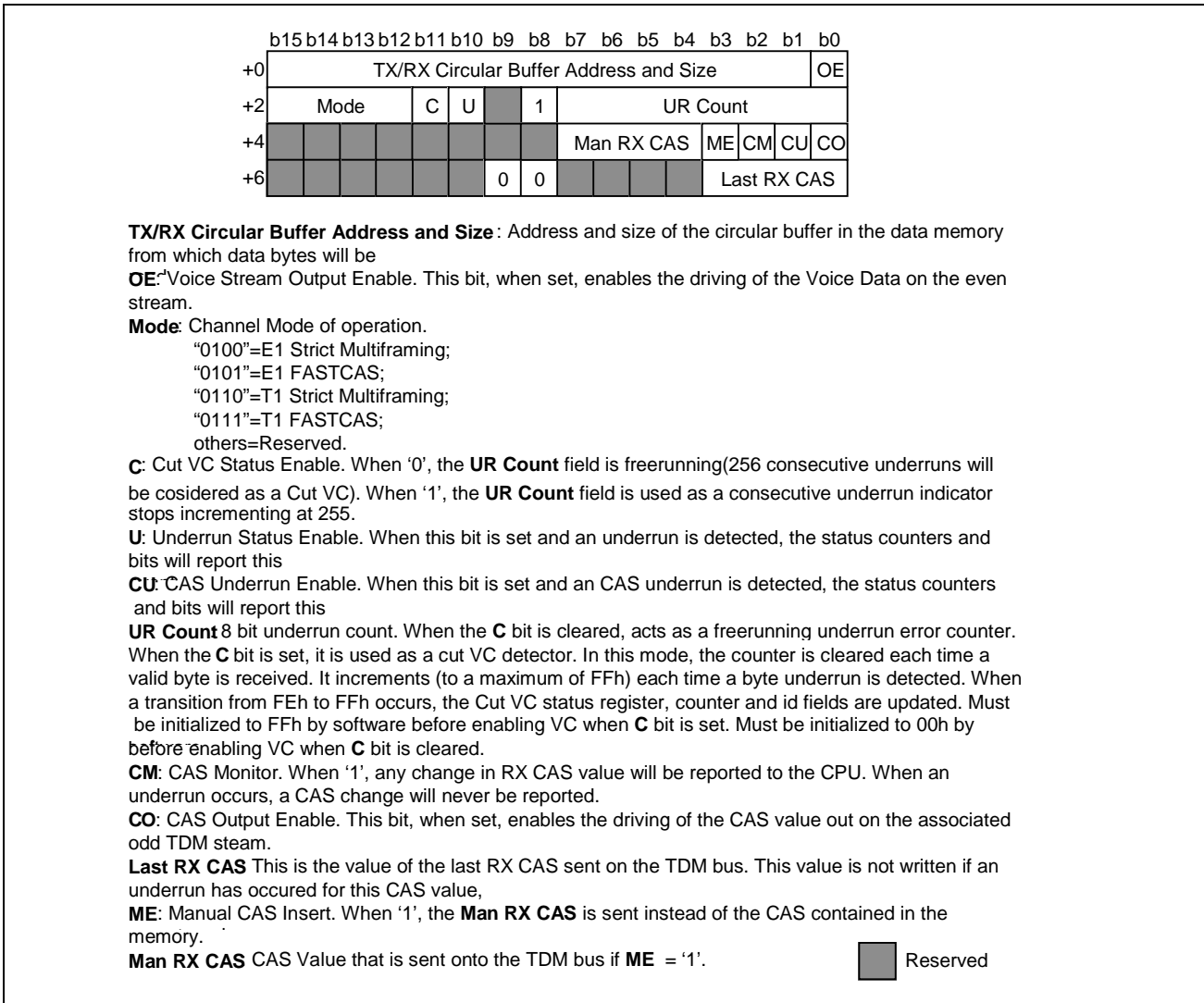

Figure 12 - TDM Channel Association: RX Channels (CAS mode)

The channel association structure for multiframe channels is slightly different, with only one bit being positioned differently in the structure. While the circular buffer address and size field is still present and functions in the same way, the mode bits are coded in the same way as they are in the transmit structure for multiframe channels. "0100" is E1, "0110" is T1, and toggling the lowest bit of either of the numbers indicates that the FASTCAS method of transmitting the data and CAS bytes are employed.

Four new fields are added to allow for CAS management on the RX side with multiframeing:

- Last RX CAS value that indicates the previous CAS bits received on ATM
- The CAS monitor bit indicates if a change in the value of CAS is to be reported by the module
- Man RX CAS is the value of CAS that can be inserted in the place of the one received. This value is only used if the ME bit is set
- ME bit Manual CAS insert

For both TX and RX channels, a change in the value of CAS on a channel where the CAS monitor bit is high will cause the new value to be written to the CAS change buffer in the external memory. This buffer contains all the values that have been detected as different from the previous value, along with the 12-bit time slot and stream value of the TDM channel to which they are associated.

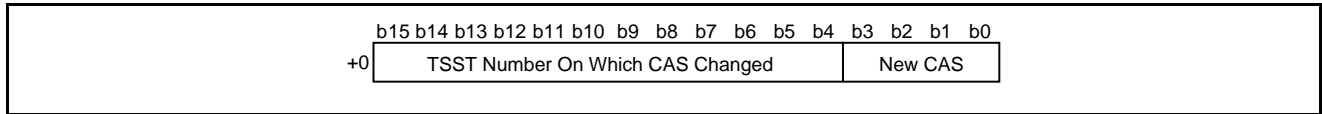

Figure 13 - CAS Change Structure in Control Memory

The Circular Buffer Address/Size field is 15 bits and the addresses are 14 bits each, an indirect method of indicating the size is used. This is done by coding the size by the first '1' that is encountered by reading the field starting from the left. For example, if the lowest bit of the field is '1', the buffer is 128 bytes (mapped on a 256 byte boundary). If the lowest bit was '0' but the second-lowest bit is '1', then the buffer is 256 bytes (mapped on a 512 byte boundary), etc.

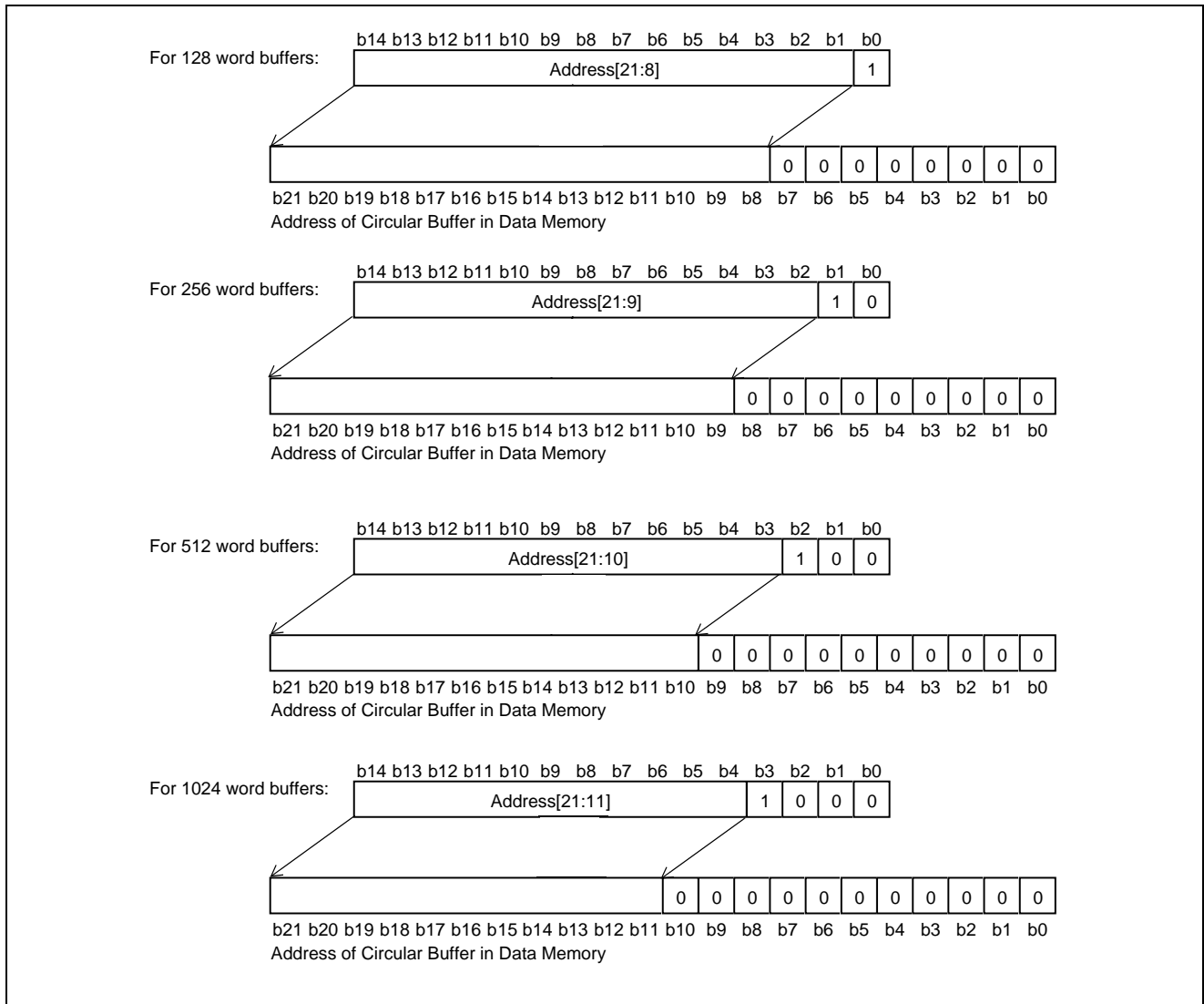

Figure 14 - TX/RX Circular Buffer and Size Field

4.2.5 TDM Circular Buffers

The TDM module writes the data received from the bus to circular buffers that are assigned on a per-channel basis. The circular buffers' size is variable and is specified in two places, i.e., once in the TDM channel association structure for which each channel has an entry, and once in the TX_SAR or RX_SAR structure which reads or writes to that channel.

The TX part of the circular buffer (data read from the TDM bus and written to the circular buffer) is contained in bits 15:8 of each circular buffer word. The RX part of the buffer is contained in the remaining bits, 7:0. This alignment allows for underrun detection and null-pattern insertion in the case of underruns. It also allows the detection of cut VCs. A cut VC is indicated when 256 consecutive underrun bytes are detected.

In the non-multiframe mode, the circular buffers are used as a single block. This means that for each channel, up to 1024 bytes of data can be stored in the channel's circular buffer. On the RX side, up to 128 ms of data can be stored for retrieval; therefore, at $n = 1$ with a packet size of 48 bytes, up to ± 61 ms of CDV can be compensated.

In multiframe mode, each 32-byte division of the circular buffer is used to store the information of one multiframe. In T1 operation, the first 24-bytes of the 32-byte division are used to remember the TDM data from the multiframe. In E1 operation, the first 16-bytes are used for the same purpose. In addition, in byte 31 of each division, the CAS value of the multiframe is stored. In this way, the multiframe portion of the TDM pointer is valid for the TDM data and for the CAS data; only the lowest bits need to be changed to "11111" in order to point to CAS.

When write backs are performed, a null byte or one of two silent patterns (background noise) can be inserted in the RX byte. The silent patterns are read from buffers of up to 64 KB. These silent patterns can be used to generate noisy silences.

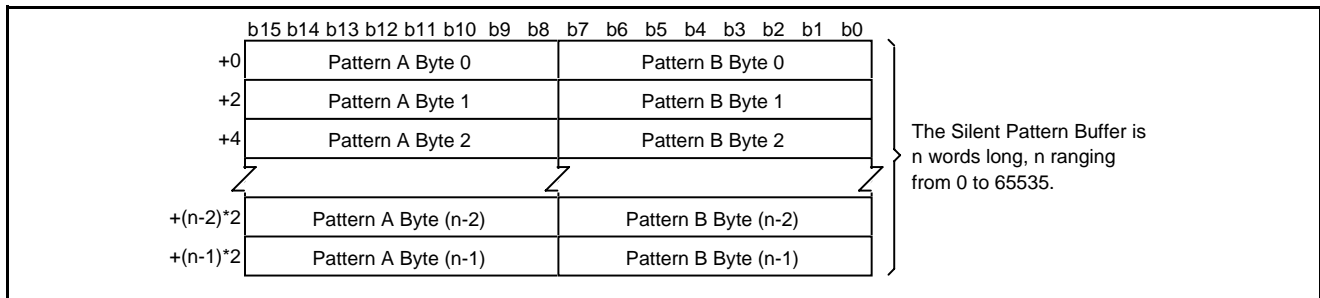

Figure 15 - Silent Pattern Buffer A/B in Control Memory

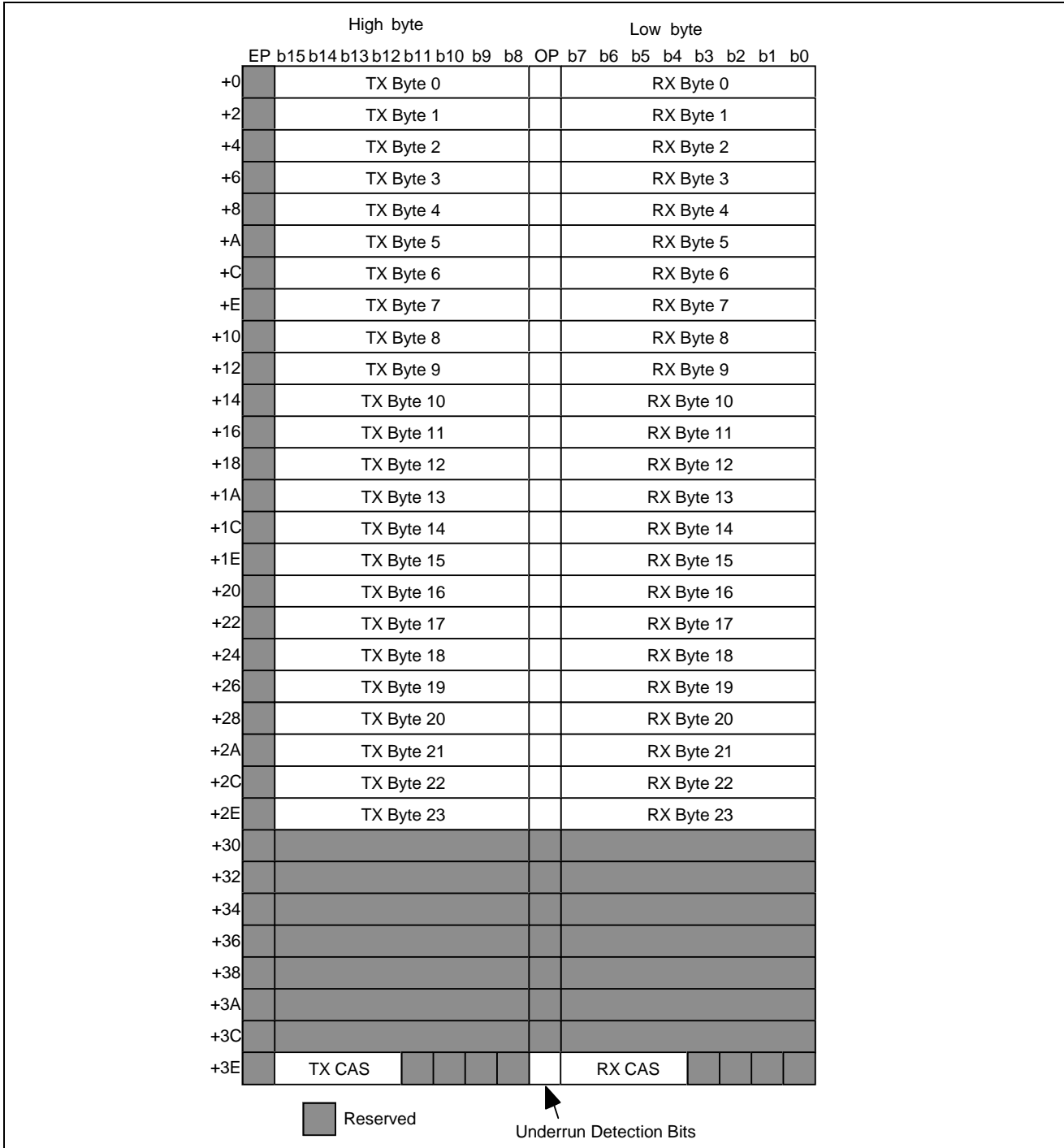

Figure 16 - TDM Circular Buffer (one MultiFrame in T1 mode)

The CAS bits are always kept in the highest four bits of the last byte.

In addition to storing the data in the circular buffers, the parity bits of the data memory are used to detect underruns generated on the ATM link. When the RX_SAR writes data to the circular buffers, it writes a '1' in the parity bit of the memory's low byte. When the TX_SAR writes data bytes in the buffer, it writes a '0' to the parity bit of the memory's low byte. Therefore, when the TDM reads the data from the circular buffer, it expects to read a '1' from the parity bit.

If it reads a '0', this means that an underrun has occurred because not enough cells are being received, or there is too much CDV.

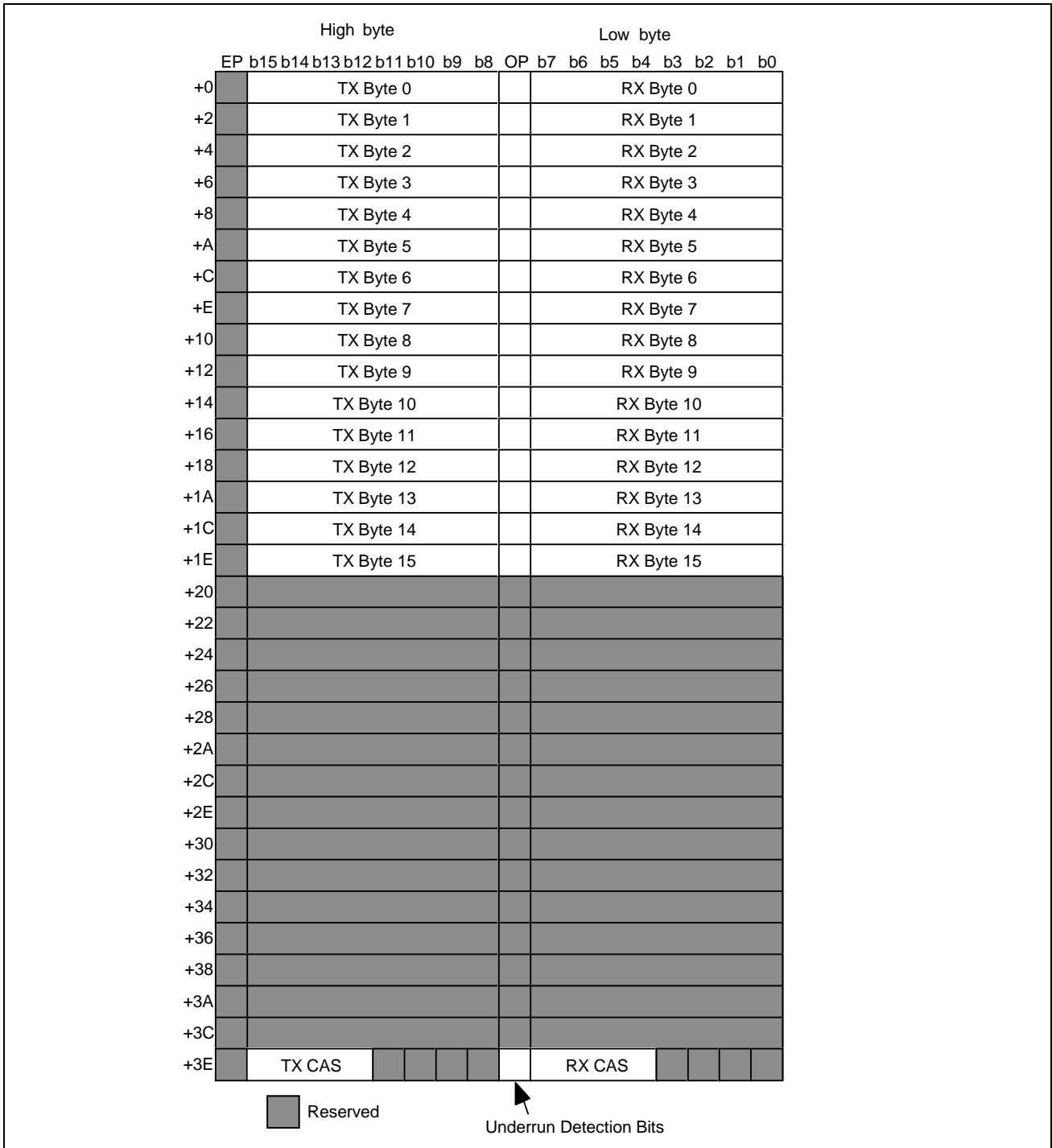

Figure 17 - TDM Circular Buffer (one Super Frame in E1 mode)

4.2.6 TDM Circular Buffer Pointers

The convention that a write pointer points to a byte that is currently being written. In like manner, a read pointer points to a byte that is currently being read. Therefore, a read and write pointer to the same buffer must never cross, or be equal to one another.

4.2.6.1 Non-multiframing mode

The global TDM_write_pointer points to the byte from the TDM bus presently being written to the circular buffers. As in all modes, the TDM_read_pointer is incremented before the TDM_write_pointer, because bytes that come from the TDM bus are written after the frame is completed. Meanwhile, bytes read from the data memory and sent onto the bus are already transmitted by the time the frame is complete.

The TDM_write_pnt sent to the TX_SAR is the same as global TDM_write_pointer. The TDM_read_pnt sent to the RX_SAR is one frame ahead of the global TDM_read_pointer. Since the TDM_read_pnt is one more than the global TDM_read_pointer, and the TDM_read_pointer is incremented before the TDM_write_pointer, the TDM_read_pnt will always have a lead of either one or two over the TDM_write_pnt.

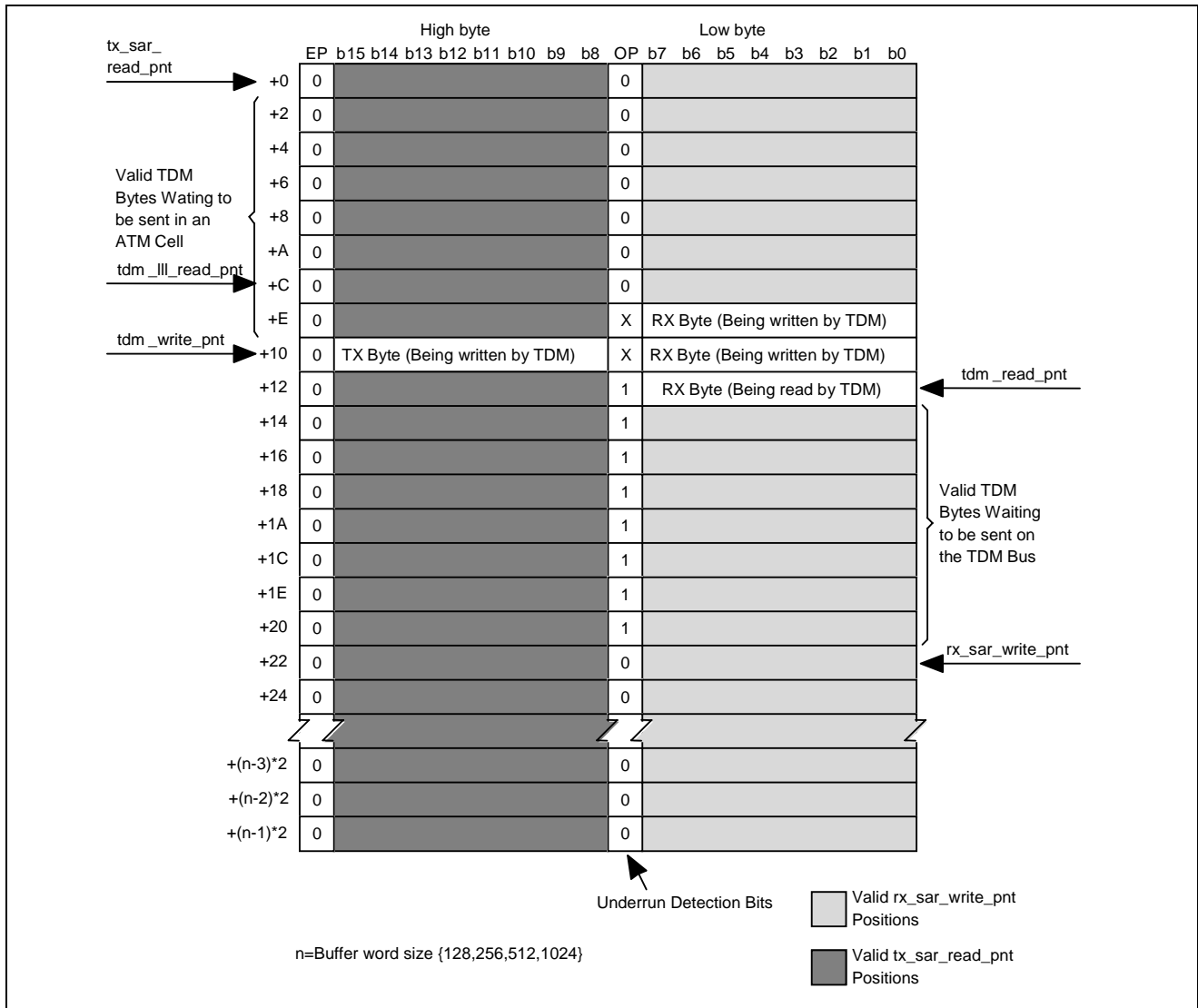

Figure 18 - TDM Circular Buffers (Normal mode)

Figure 18 TDM Circular Buffers (Normal mode) shows that very few of the positions within the circular buffer are invalid for the SAR pointers.

4.2.6.2 E1/T1 Multiframe (standard)

The TDM pointers change to respect the multiframe standards required by E1 and T1 operation. The pointer has two halves. One half indicates the number of the multiframe that the TDM is writing or reading; the other half is the number of the frame within the multiframe. In the T1 mode, this fraction goes from 0 to 23, while in the E1 mode it ranges from 0 to 15. The same global standards of pointer definition still apply as the pointer still points to an invalid byte.

The TDM_write_pnt has a global value, which is the value of the internal multiframe pointer. However, due to the multiframe offset, the TDM_write_pnt can vary by almost an entire frame. Therefore, if the global TDM_write_pointer points to 0.0 (Multiframe 0, frame 0) the individual TDM channels may be written anywhere from 0.0 to 0.23 in the T1 mode, and from 0.0 to 0.15 in the E1 mode. The TDM channels may be written almost an entire frame ahead of the global pointer. The pointer sent to the TX_SAR is the same as the global TDM_write_pointer.

The TDM_read_pnt is two multiframe ahead of the TDM_write_pnt. The need for this lead arises from the write backs and from CAS. Since the TDM_write_pnt can be writing up to 15 frames ahead, a lead of at least one multiframe must be given. In addition to this, the CAS must be considered. CAS is written during the multiframe of the tx, which can be up to one multiframe ahead of the global pointer. When CAS is read from the rx side it is read at the beginning of the multiframe. Therefore, to ensure that there is always a difference of at least one in the CAS pointers, the delta between the TDM pointers is established at two multiframe.

Furthermore, the read pointer that is sent to the RX_SAR is almost one multiframe ahead. This is necessary because CAS is sent at the end of the multiframe on the ATM side, and is read at the beginning of the multiframe on the TDM side. Therefore, to ensure that the CAS of the multiframe is written by the RX_SAR before the TDM reads it, the pointer passed to the RX_SAR is incremented by one multiframe minus one frame. Therefore, if the TDM_read_pointer would have been 2.5 (two multiframe, five frames), the TDM_read_pnt passed to the RX_SAR is 3.4 (three multiframe, four frames).

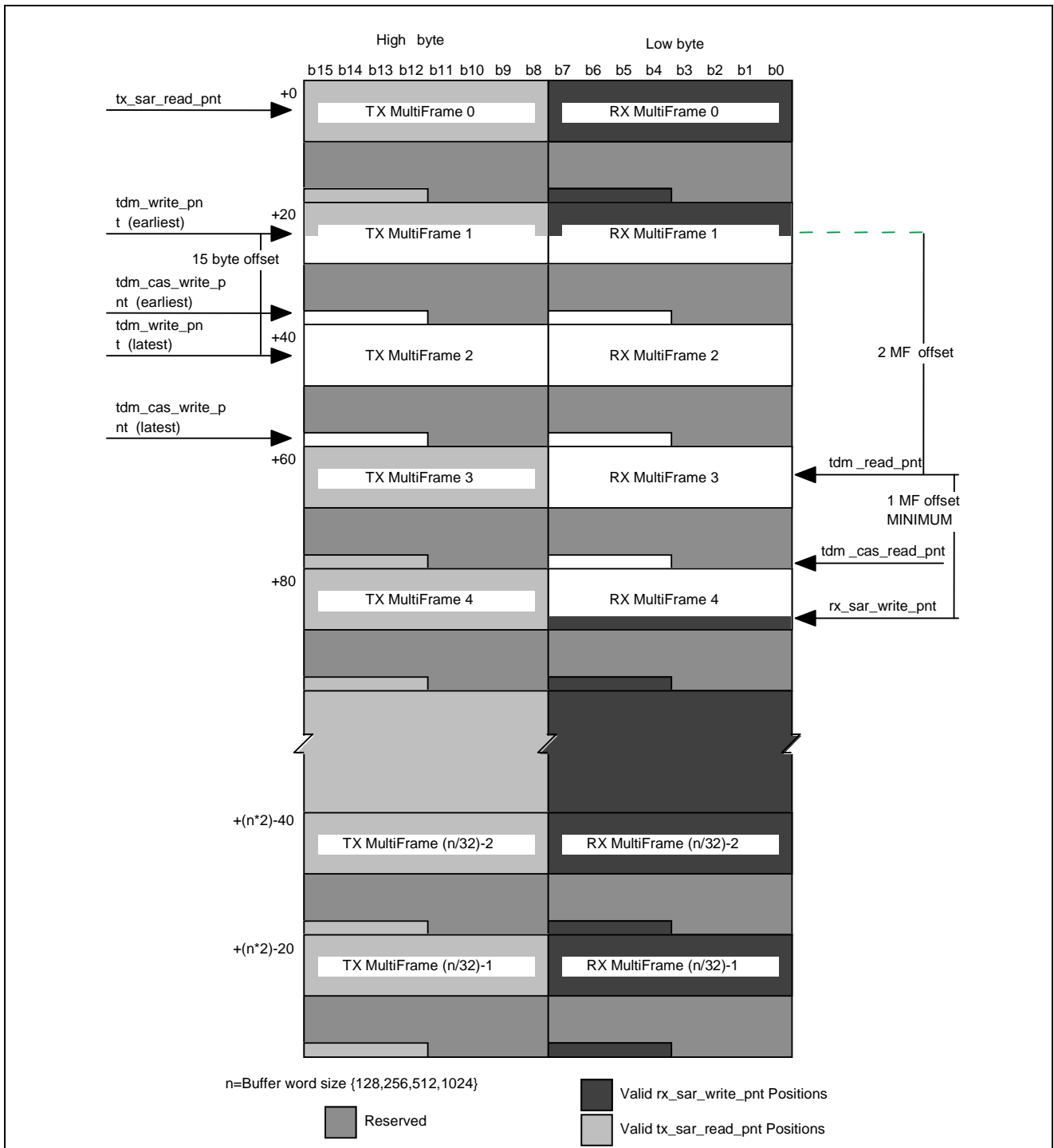

Figure 19 - TDM Circular Buffer (Complete Buffer in E1 mode, Strict Multiframing)

Figure 19 TDM Circular Buffer (Complete Buffer in E1 mode, Strict Multiframing) shows the TDM circular buffer in the E1 mode. The buffer is only half used for the TDM data. The CAS is located at the end of the buffer, and the write and read pointers are offset by a full three multiframes.

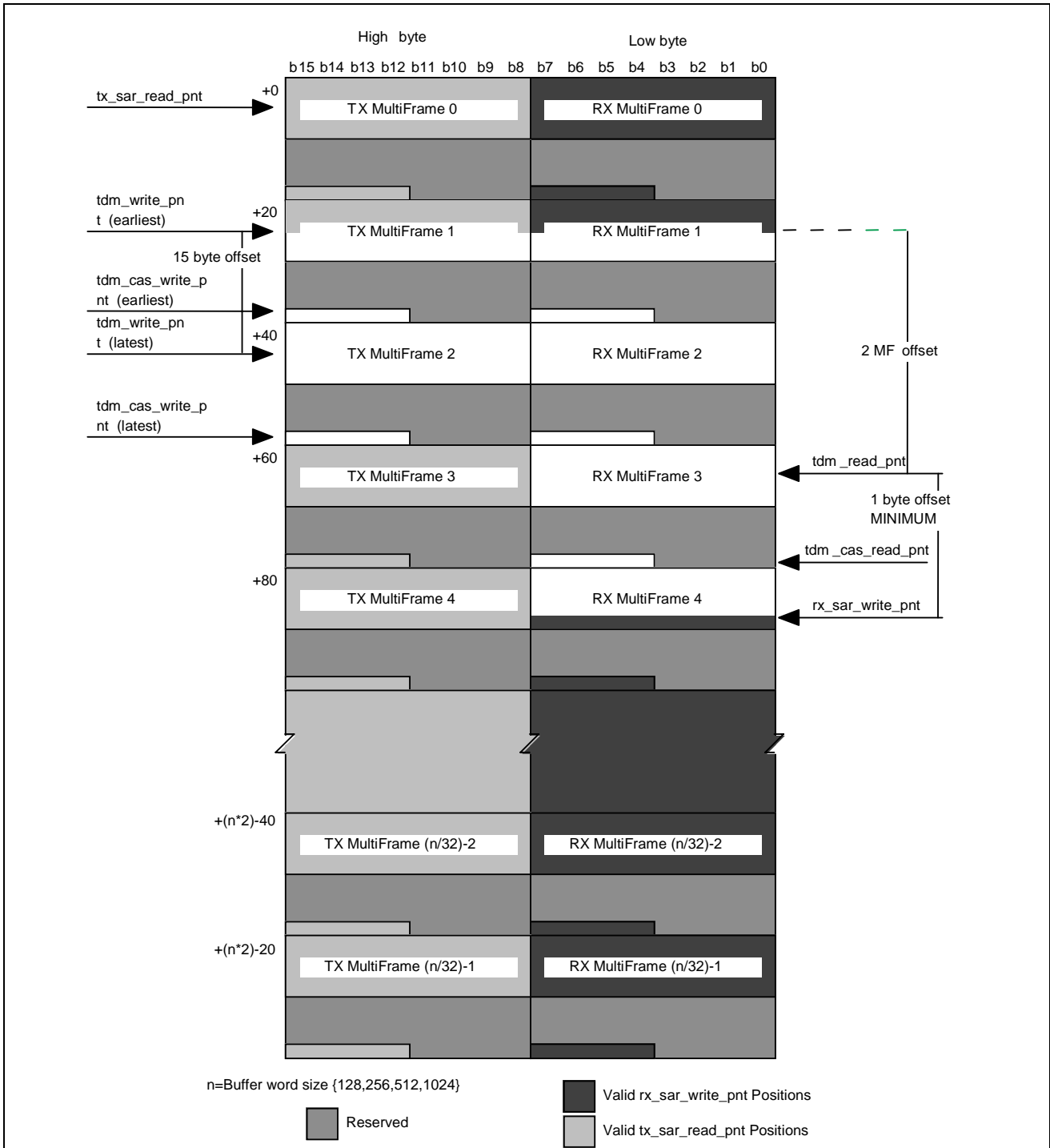

Figure 20 - TDM Circular Buffer (Complete Buffer in E1 mode, FASTCAS)

Figure 20 TDM Circular Buffer (Complete Buffer in E1 mode, FASTCAS) is an E1 circular buffer in the FASTCAS mode. Although the TDM read and write pointers are still significantly offset, the delay has been reduced to nearly zero. This is because the rx_sar_write_pnt and the TDM_read_pnt need only be offset by a single byte, as in non-multiframing mode.

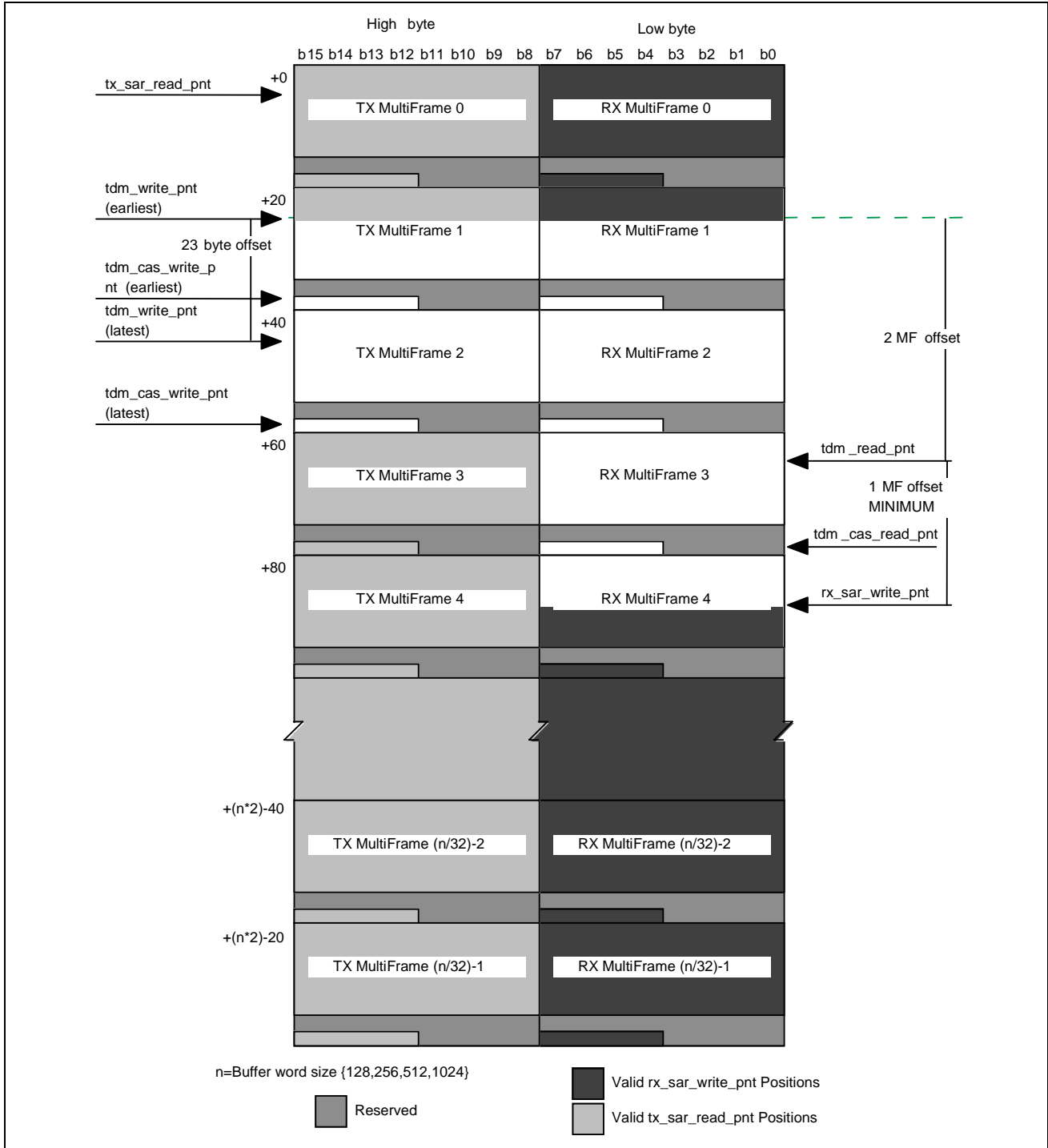

Figure 21 - TDM Circular Buffer (Complete Buffer in T1 mode, Strict Multiframe)

Figure 21 TDM Circular Buffer (Complete Buffer in T1 mode, Strict Multiframe) shows a T1 circular buffer in standard multiframe mode. The T1 circular buffer is identical to an E1 circular buffer except that the multiframe are 24 bytes instead of 16 bytes.

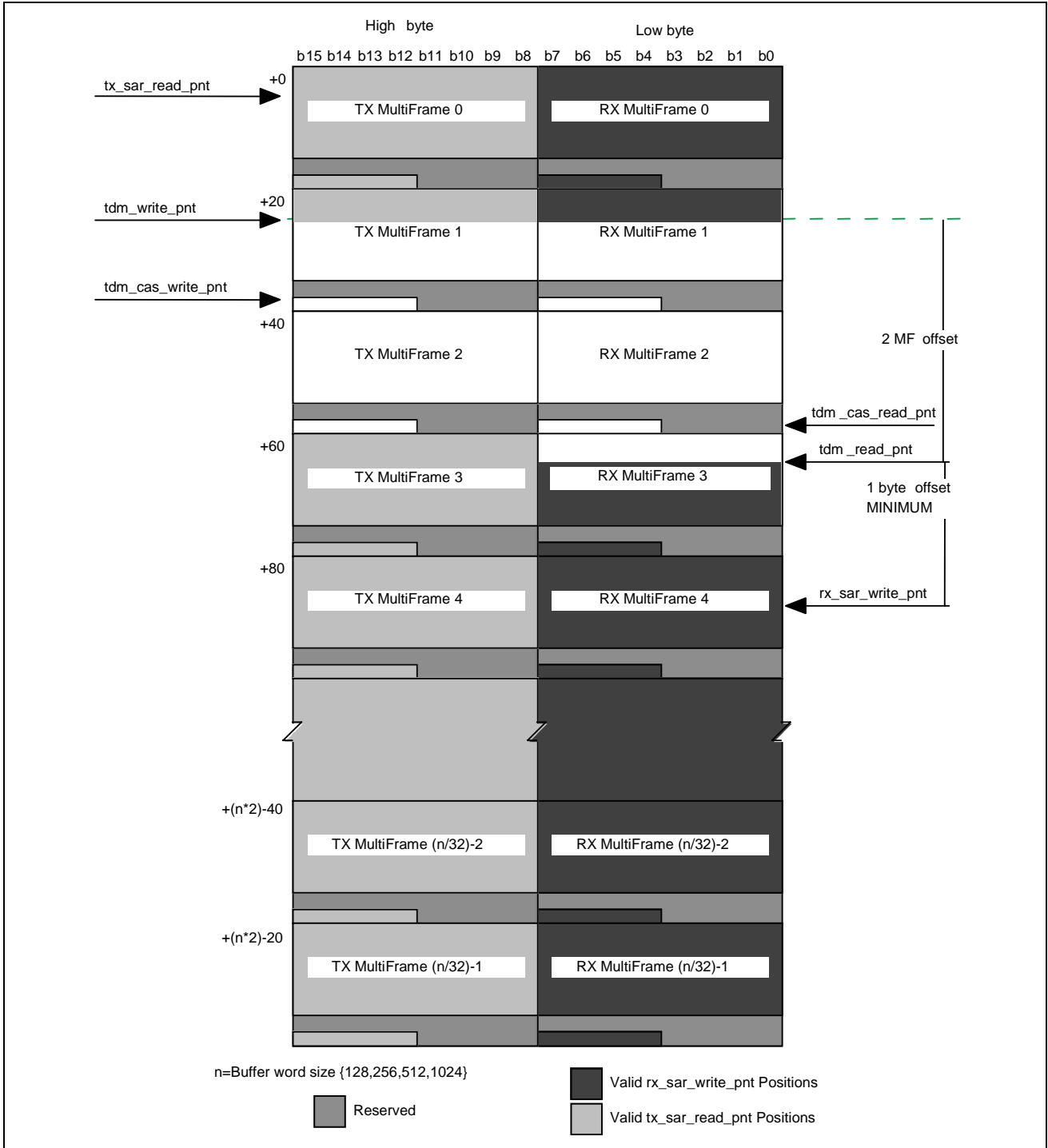

Figure 22 - TDM Circular Buffer (Complete Buffer in T1 mode, FASTCAS)

Figure 22 TDM Circular Buffer (Complete Buffer in T1 mode, FASTCAS) shows a T1 circular buffer in FASTCAS mode. The T1 circular buffer is identical to an E1 circular buffer except for the fact that the multiframes are 24 bytes instead of 16 bytes.

4.3 TX_SAR Module

4.3.1 Overview

The purpose of the TX_SAR Module is to assemble TDM data bytes into ATM cells to be transmitted to the UTOPIA Module. The TX_SAR Module has no external interfaces, and does not control any of the MT90503's pins. However, it is the connecting block between the TDM module and the UTOPIA Module in the data transmission direction.

When the TX_SAR assembles ATM cells, it reads bytes from the circular buffers in data memory and uses these to assemble the ATM cells.

In order to transmit CBR ATM cells correctly, a timing algorithm is used to ensure that the ATM cells are assembled and transmitted at the defined data rate. This timing algorithm is implemented using the transmit event scheduler. The transmit event scheduler is a construct in control memory that identifies the time ATM cells need to be transmitted, and the circular buffer from which data for the ATM cell is to be retrieved. ATM cells are capable of carrying a variable number of virtual channels. Therefore, the rate at which cells are transmitted is variable.

4.3.1.1 Support and Trunking for Different Types of ATM Cells

The type of ATM cells the TX_SAR supports includes AAL1, CBR-AAL0, and AAL5-VTOA. The transmit event scheduler is capable of supporting the different data rates which are inherent to the different types of ATM cells. Figure 23 - ATM Cell Formats shows the different formats for the ATM cells that the TX_SAR Module supports.

The TX_SAR is also capable of supporting hyperchannels (trunking) of up to 2048 channels per VC. In addition, it can also support AAL0 and AAL5 trunking, providing the number of channels is divisible by the payload bytes.

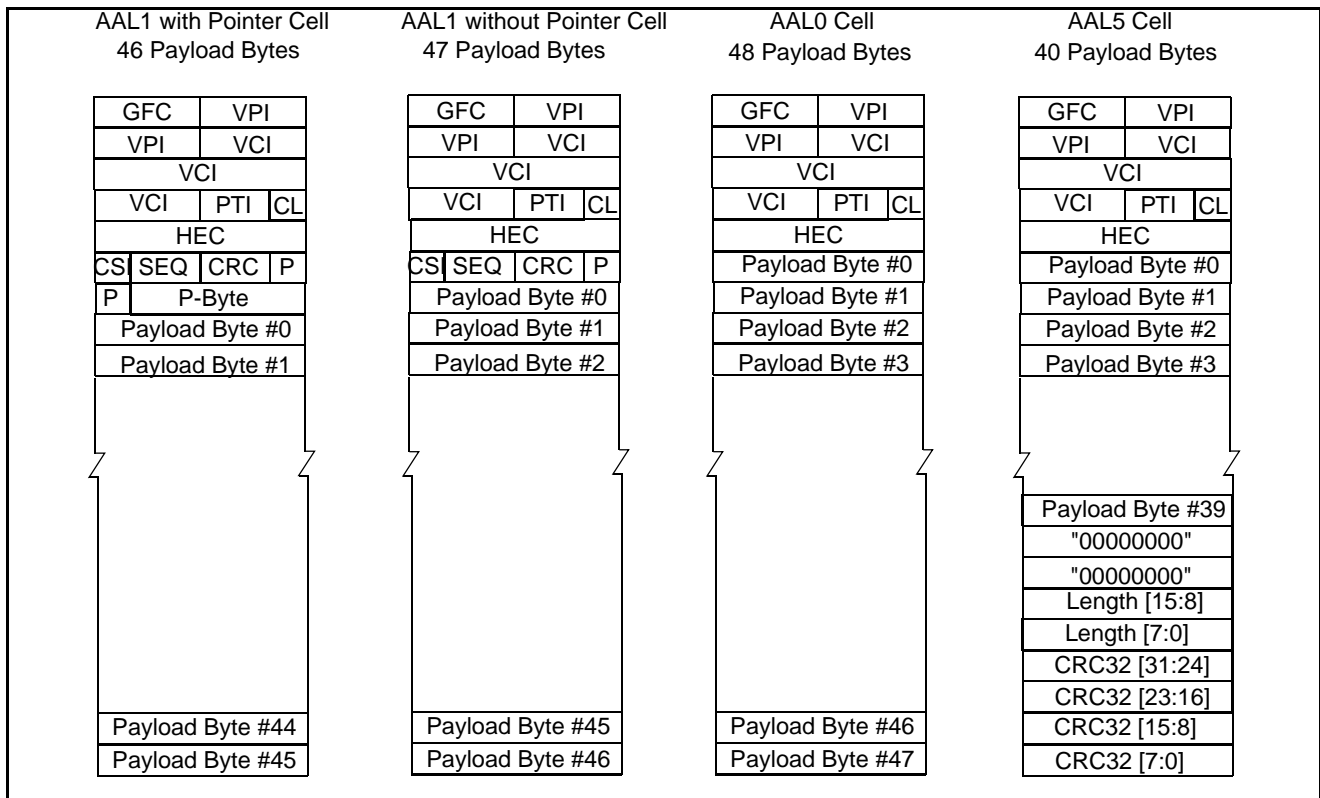

Figure 23 - ATM Cell Formats

4.3.2 TX_SAR Event Schedulers

4.3.2.1 Overview

The purpose of the transmit event scheduler is to ensure that the MT90503 assembles and transmits ATM cells at the appropriate time. This timing function is implemented to reduce data overruns and underruns.

Before arriving at the TX_SAR, TDM channel data is written into a variable-length (128 to 1024 bytes) transmit circular buffer, a construct in external data memory, by the TDM Module. Each TDM channel is assigned its own transmit circular buffer (see section 4.2.6 TDM Circular Buffer Pointers). The transmit event schedulers determines when the information will be assembled into ATM cells.

The 15 transmit event schedulers are identical, and all have individual configuration registers. Each transmit event scheduler is divided into a programmable number of frames. When configured correctly, each transmit event scheduler frame is constrained to an average of 125 μ s (i.e. the time required for one byte to be received/transmitted on each TDM channel).

4.3.2.2 The Transmit Event Scheduler Process

Please refer to Figure 24 - Transmit Event Scheduler Process in conjunction with this subsection.

The MT90503's 15 transmit event schedulers are all maintained in a designated memory block in the external control memory. Each transmit event scheduler can be programmed to support one of the four types of cells (AAL1 with or without pointer, CBR-AAL0, or AAL5-VTOA). Each of the transmit event schedulers can be enabled or disabled via registers (0610h - 0616h) in order to use less bandwidth if a certain format of ATM cell is not required. Figure 24 - Transmit Event Scheduler Process provides an example of one of the 15 transmit event schedulers in the MT90503. All transmit event schedulers have exactly the same properties, and all perform the same functions. They can be configured individually to handle different VC configurations.

Each of the 15 transmit event schedulers is made up of a number of "frames", with each frame containing a number of events. An event, if executed, consists of the assembling and placing in a UTOPIA output FIFO of one ATM cell. The base address, length, and number of events can be programmed for each scheduler frame. Each transmit event scheduler has its own Scheduler Base Address which, in conjunction with an internal frame counter, will locate the events in a specific frame.

In order for an ATM cell to be assembled and transmitted at the appropriate time, the following transmit event scheduler process steps are required:

- 1 On the reception of a frame pulse, the scheduler scans through the events of the current frame.
- 2 For each valid event in the current frame, a cell is assembled and transmitted to the UTOPIA module.
- 3 On the reception of the next frame pulse (125 μ s later) or upon the completion of the final valid event in the current frame, whichever is later, the scheduler increments current frame, to point to the next frame in the scheduler.
- 4 The scheduler reads each frame sequentially, returning to frame 0 upon completion of the final frame in the scheduler.

An analogy can be made of the above process to a continuous "spinning wheel", where there is a continual selection and reading of events for each transmit event scheduler frame. Table 19 - Scheduler Event Fields provides a description of the fields for one of the transmit event schedulers. Refer to Figure 24 - Transmit Event Scheduler Process to locate the fields.

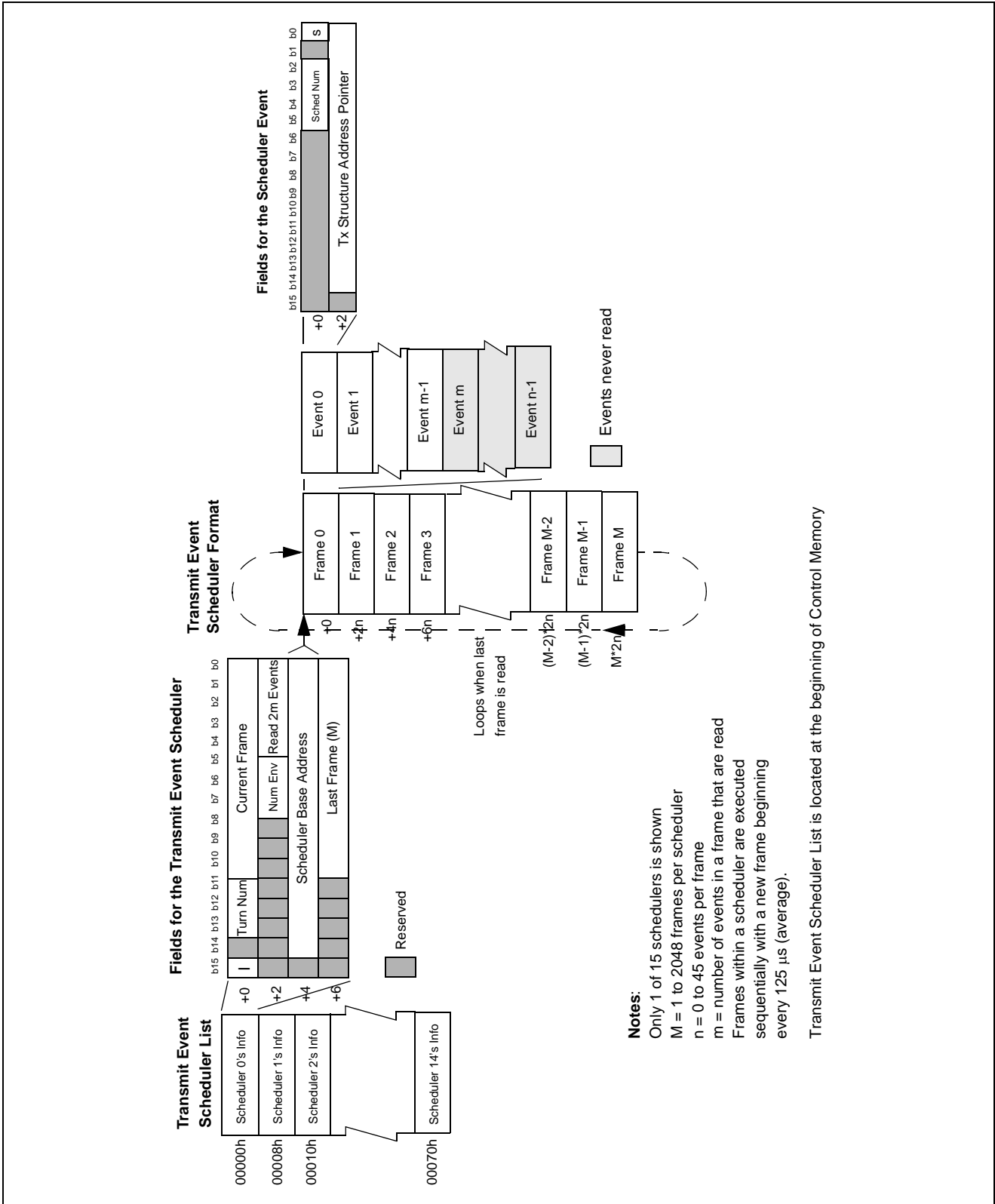

Figure 24 - Transmit Event Scheduler Process

4.3.2.3 Transmit Event Scheduler Fields Description

Table 18 - Field Description for the Transmit Event Scheduler provides a description of the fields for the transmit event scheduler. Please refer to Figure 24 - Transmit Event Scheduler Process to locate the fields.

Field	Name of Field	Bits Used	Description of Field														
I	Scheduler Initialised Bit	+0/b15	This bit is reset by software immediately before enabling the transmit event scheduler. Hardware will set this bit the first time it reads the scheduler information structure. When the I bit is read at '0' by hardware and the scheduler is used for T1/E1 support, the transmit event scheduler's Current Frame will be written between 0-23 for T1 and 0-15 for E1 in order for frame 0 to correspond to the first byte of a multiframe.														
Turn Num	Free run counter of scheduler wraps	+0/b13:b11	Turn Num is a counter used for the implementation of multiframing. The scheduler re-synchronises itself with the multiframe count when Turn Num is 0.														
Current Frame	Current Frame	+0/b10:b0	Current Frame is used to record the frame position of the transmit event scheduler. Range 0 to (Last Frame)														
Num Env	Number of events per frame in the scheduler	+2/b7:b5	The number of events per frame is $2^{(\text{Num Env})+1}$. The same number applies to all frames in the scheduler. Range:000 to 101 (2 to 63 events per frame). All others reserved.														
Read 2m Events	Read 2m First Events	+2/b4:b0	Indicates to the scheduler how many events in each frame must be read. The same number applies to all frames in the scheduler. <table style="margin-left: auto; margin-right: auto;"> <thead> <tr> <th style="text-align: center;"><u>m</u></th> <th style="text-align: center;"><u>Events Read</u></th> </tr> </thead> <tbody> <tr> <td style="text-align: center;">0</td> <td style="text-align: center;">64</td> </tr> <tr> <td style="text-align: center;">1</td> <td style="text-align: center;">2</td> </tr> <tr> <td style="text-align: center;">2</td> <td style="text-align: center;">4</td> </tr> <tr> <td style="text-align: center;">.</td> <td style="text-align: center;">.</td> </tr> <tr> <td style="text-align: center;">.</td> <td style="text-align: center;">.</td> </tr> <tr> <td style="text-align: center;">31</td> <td style="text-align: center;">62</td> </tr> </tbody> </table>	<u>m</u>	<u>Events Read</u>	0	64	1	2	2	4	31	62
<u>m</u>	<u>Events Read</u>																
0	64																
1	2																
2	4																
.	.																
.	.																
31	62																
Scheduler Base Address	Pointer to the beginning of the transmit event scheduler	+4/b14:b0	This field is appended with "00000" as the LSBs, to form a 20-bit address. <u>Note:</u> A frame must never cross a boundary of its own size in memory. Therefore, if the transmit event scheduler has more than 8 events per frame (32 bytes per frame), then some LSBs of this field must be 0.														
Last Frame (M)	Last Frame (M)	+6/b10:b0	Last Frame = (number of frames in the scheduler) - 1. If Last Frame = 0, the scheduler is one frame long, if Last Frame = 1, the scheduler is two frames long, etc.														

Table 18 - Field Description for the Transmit Event Scheduler

The number of events per frame in the scheduler, Num Env, determines how much memory is allocated for each frame in the scheduler: 2 words per event. Within this memory, the scheduler will read only the first 2m events, as stored in the Read 2m Events field. Of the events that are read, only those with the Scheduler Num not equal to '1111' (see Table 19) are executed. No action is taken on events that are read whose Scheduler Num is '1111'.

4.3.2.4 Scheduler Events Fields Description

Table 19 - Scheduler Event Fields provides a description of the fields for the transmit event scheduler entries. Figure 24 - Transmit Event Scheduler Process to locate the fields

Field	Name of Field	Bits Used	Description of Field
Scheduler Num	Transmit Event Scheduler Number	+0/b5:b2	This field contains the scheduler number. 0000 to 1110 = valid scheduler numbers 1111 = invalid event. No action will be taken on this event The transmit event schedulers are read sequentially.
S	Start Bit	+0/b0	This field indicates the first event that will be carried out when the VC is initialised. Software must set the S bit of only one event once programming of the scheduler is complete. This bit is only relevant until the I bit is set in the TX Control Structure. After the I bit is set, all events with valid scheduler numbers will be executed as they are encountered.
TX Structure Address Pointer	TX Structure Address Pointer	+2/b14:b0	This field is the pointer to the TX_SAR Structure used to assemble an ATM cell each time this event is read. This field is appended with "00000" as the LSBs to form a 20-bit address.

Table 19 - Scheduler Event Fields

4.3.2.5 Bandwidth Limitations for Transmit Scheduler Events

Transmission Speed	Maximum Number of Events per Frame
25 Mbps	7
155 Mbps	45
622 Mbps	183

Table 20 - Maximum number of Events per Frame for Common Transmission Speeds

The maximum number of events per frame corresponds to the maximum number of events that can occur in one frame of all the schedulers simultaneously.

If the frames are not synchronised (as in Figure 25 - Unsynchronised Schedulers), the maximum number of events per frame is the sum of the maximum events in any frame of each scheduler (in this case, 32 events + 21 events = 53 events is the maximum number of events per frame). If the schedulers are synchronised (as in Figure 26 - Synchronised Schedulers), the maximum number of events per frame is the worst in any particular frame (in this case, 23 + 17 = 40 events is greater than 6 + 24 = 30 events, so 40 events is the maximum number). If the schedulers are partially synchronised (as in Figure 27 - Partially Synchronised Schedulers), the maximum number of events per frame is the worst in any frame that can possibly align (in this case, 20 + 5 = 25 events is less than 27 + 12 = 39 events which is greater than 20 + 16 = 36 events and 27 + 7 = 34 events so 39 events is the maximum number).

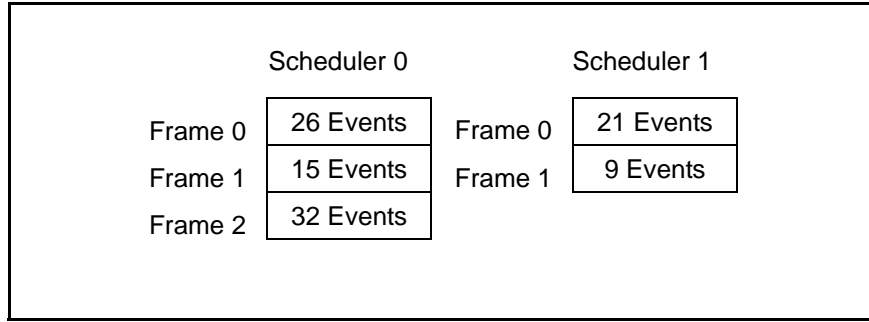

Figure 25 - Unsynchronised Schedulers

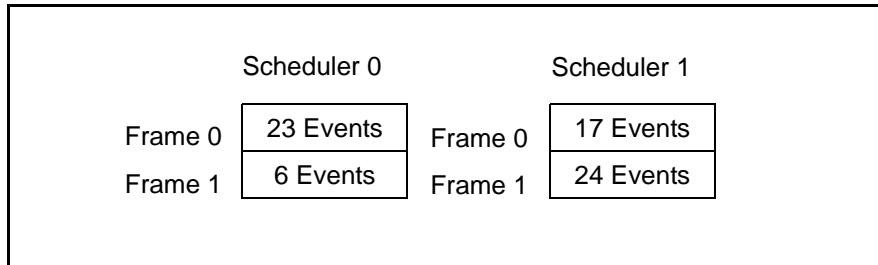

Figure 26 - Synchronised Schedulers

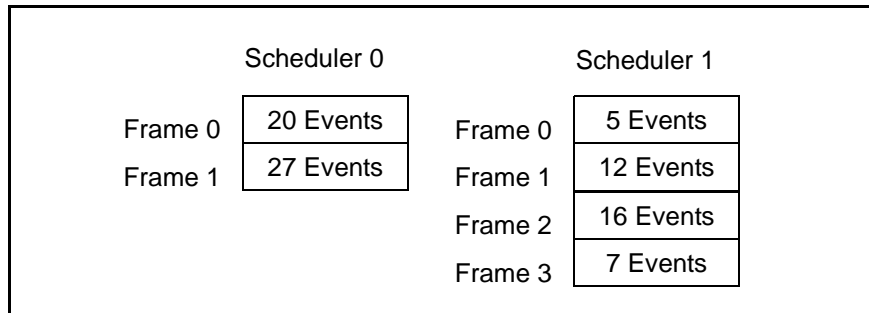

Figure 27 - Partially Synchronised Schedulers

4.3.3 Out of Bandwidth Error

The TX_SAR out-of-bandwidth error indicates that a particular region of the scheduler, or the scheduler as a whole, is overloaded. This error occurs when the TX_SAR lagging by F frames or more, where F is an integer written to register 0608h. The TX_SAR has 125 μs to execute all the events in the frame it is servicing at the current time. If all the events in the frame are not executed within 125 μs, the TX_SAR continues until the end of the current frame before moving on to events in the next frame. This method reduces the amount of time it has to service the following frame. If the first frame took 150 μs to service, then there would only be 100 μs left to service the following frame. Therefore, if the second frame is also very full, the TX_SAR would not have the time to finish servicing it and will be late again for the following frame.

If frames take an excessively long time to service, the MT90503 may become several frames late. If the MT90503 detects that it is F or more frames late, an out-of-bandwidth error will be declared and the MT90503 will skip the next F frames of events. This action will cause latency in the transmission delay and corrupt data on the VCs until the channel reconverges. The channel reconverges once every 375 frames (47 ms) in “AAL1 with pointer” schedulers, and less often if multiframing is used. The cells that were supposed to be assembled in the F missing frames are skipped, and new cells are assembled with the old data. The out-of-bandwidth error arises from an error

with the mapping of the transmit event scheduler. Despite this error, the MT90503 will continue with its operations, however, some cells may be lost.

4.3.3.1 Percent of Bandwidth Register

The TX_SAR incorporates a Percent of Bandwidth register (0510h), which indicates the maximum number of mclk cycles utilised by the TX_SAR process per frame. The Percent of Bandwidth register counts the number of mclk cycles from the time that a frame is received, to the time that all the entries for that frame in the schedulers have been completely handled. This value will be compared to the current maximum value obtained by the TX_SAR process. If the most current value is higher, it is retained and written into the Percent of Bandwidth register. The value in the Percent of Bandwidth register can be cleared by the software. If the TX_SAR takes more than 125 μ s to assemble the cells of a particular frame, the Percent of Bandwidth register's value will be greater than the number of mclk cycles in the 125 μ s time frame.

4.3.3.2 Distribution of Events by Software

The events in the transmit event scheduler need to be distributed as evenly as possible. For example, an "AAL1 with pointer" 3-channel VC has three events per 46.875 frames. These events must be spaced out with a distance of 15 or 16 frames between events to prevent irregular data distribution resulting in transmission latency and/or data integrity problems. Consequently, a scheduler $8 * 46.875 = 375$ frames in length containing 24 events is required to map the three events per 46.875 frames evenly. The mapping of this information is accomplished by external software.

One of the key features of the transmit event schedulers is their programmable length. Since different cells require different sizes of schedulers, the schedulers are capable of handling any scheduler length from 1 to 2048 frames.

Refer to Table 21 for examples of transmit event scheduler sizes.

ATM Cell Type	Number of Frames	Transmit Event Scheduler size in KB (e.g. 32 events per frame)
CBR-AAL0	48	6*
AAL1 with Pointer	375	47
AAL1 without Pointer	47	5.875
AAL5-VTOA/CBR-AAL0	240	30
E1 with CAS	750	94
T1 with CAS	1125	141
*Note: 6 KB = 32 events per frame * 48 frames per scheduler * 4 bytes per event		

Table 21 - Examples of typical Transmit Event Scheduler Sizes

4.3.4 Mapping of the Transmit Event Scheduler

With the "AAL1 with pointer", the format for the mapping of the transmit event scheduler is asymmetric. The "AAL1 with pointer" format expects a cell every 46.875 frames per channel, a transmit event scheduler with 47 frames that skips the last frame one turn out of eight is required. The MT90503 overcomes this difficulty by creating an extended transmit event scheduler of 375 frames, which is $8 * 46.875$. Therefore, the irregularity of the transmit event scheduler is corrected and events can be mapped appropriately.

Due to this multiplication, the number of events mapped in the transmit event scheduler for any VC is always a multiple of eight. This means the first event in the transmit event scheduler is always a p-byte event and contains a zero value pointer indicating the start of a structure.

4.3.5 TX_SAR Control Structures

TX_SAR control structures are constructs in control memory which contain ATM cell information. When a frame event is read from one of the 15 transmit event schedulers, an ATM cell is assembled. The scheduler event contains the base address that points to the control structure that is used for assembling the ATM cell. The control structure contains all of the fields that are required for assembling the ATM cell. The destination field in the control structure is responsible for telling the UTOPIA Module the destination VC of the assembled ATM cell. For detailed information regarding the destination field, refer to Table 22, 'Description of the Fields for the TX_SAR Control Structure', on page 65.

Figure 28 - TX_SAR Event Scheduler Pointer Flow and Control Structure shows a functional block diagram of an example of transmit event scheduler interconnections and pointer flow to the TX_SAR control structure.

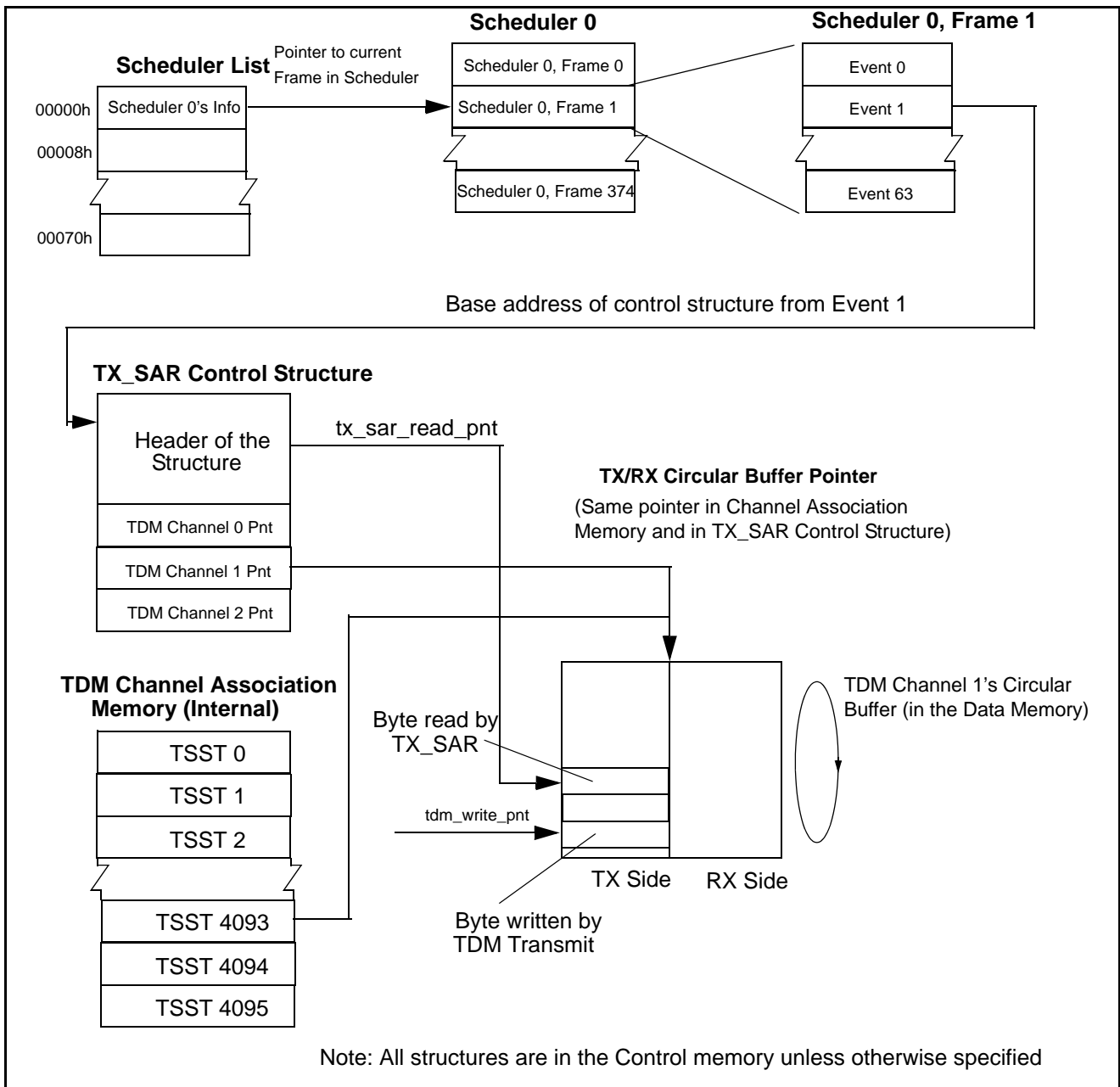

Figure 28 - TX_SAR Event Scheduler Pointer Flow and Control Structure

4.3.5.1 TX_SAR Control Structure Fields

Figure 29 - TX_SAR Control Structure shows the TX_SAR control structure format and data fields held in control memory. Table 22, Description of the Fields for the TX_SAR Control Structure describes the data fields.

The header for the ATM cell to be constructed is derived from words +8 and +A in the TX_SAR control structure. The final 8 bits of the cell header, the Header Error Check (HEC), are calculated and inserted by the UTOPIA module. The channel entries, beginning at +16h, are 14-bit pointers to the circular buffers in external data memory, one for each channel in the VC.

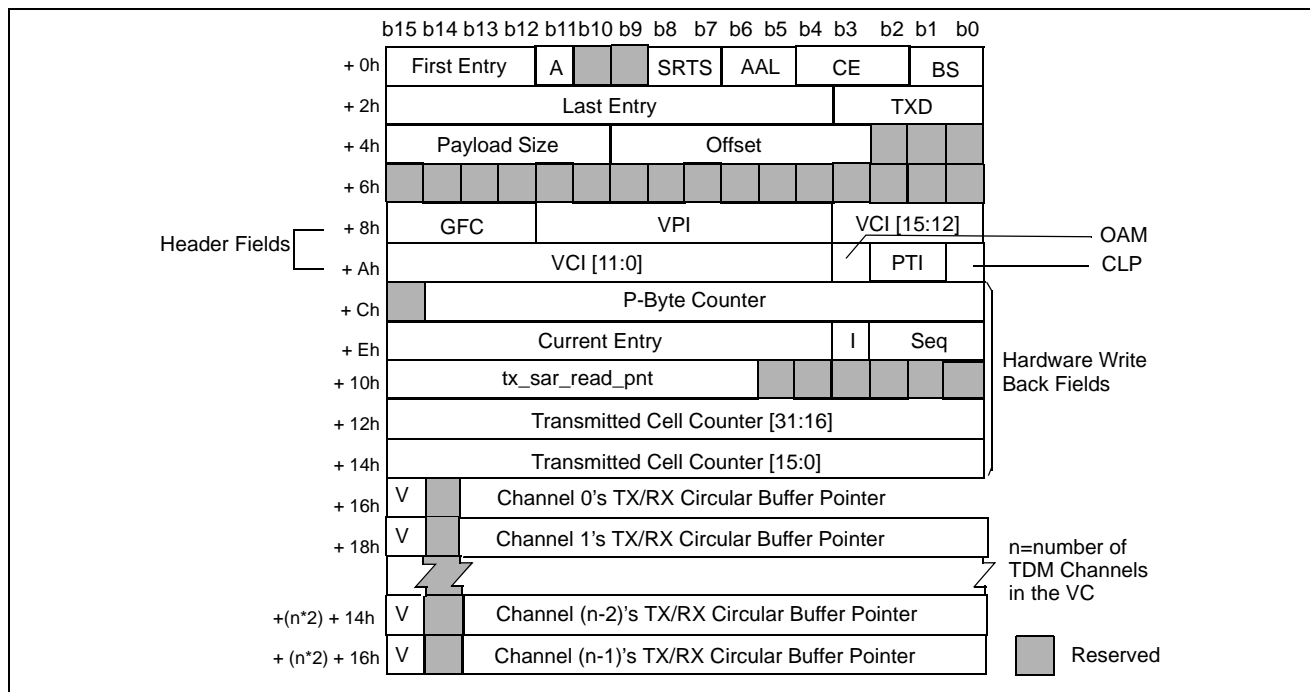

Figure 29 - TX_SAR Control Structure

Field	Name of Field	Byte Address Offset /Bits Used	Description of Field
First Entry	First Entry	+0/b15:b12	First entry gives the position within the structure of the pointer to the first channel. The field is a word pointer and is constant with a value of 0xB. To allow for future structure updates, its value is programmable. Channel 0's address is located at base_add + (2 * First Entry).
A	Structure Active	+0/b11	This bit indicates whether or not the VC is active. The control structure becomes active when A is set. The A bit is set by software. If the A bit is reset, the control structure will always be ignored. If the A bit is set, hardware may ignore it for other reasons, such as the control structure not being initialised.

Table 22 - Description of the Fields for the TX_SAR Control Structure

Field	Name of Field	Byte Address Offset /Bits Used	Description of Field
SRTS	Synchronous Residual Time Stamp	+0/b8:b7	<p>The SRTS bits indicate the generation of SRTS within the VC. SRTS is either absent, enabled, or enabled and master. Many VCs can be programmed to transmit SRTS, but only one can request a new SRTS value. If many VCs transport SRTS, they must all be of the same size, i.e., the same number of channels, to ensure the validity of the values. If SRTS is generated on the VC, it is packaged within the AAL1 byte of cells 1, 3, 5 and 7 of an 8-cell cycle.</p> <p>The SRTS field should never be enabled on CBR-AAL0 or AAL5-VTOA VCs. If SRTS is enabled on multiple VCs, the events must be mapped in such a way that an event that generated cell # 0 for the master VC occurs before the event that generates cell # 0 for all the other VCs.</p> <p>The SRTS field bits are encoded as follows: 00 = No SRTS 01 = Reserved 10 = Send SRTS 11 = Send SRTS, and request a new SRTS value on Seq = 7</p>
AAL	Adaptation Layer	+0/b6:b5	<p>The AAL bits indicate the ATM format to be used to assemble the cells in this structure.</p> <p>The AAL field bits are decoded as follows: 00 = CBR AAL0. Consists of CBR data 01 = AAL5-VTOA. Includes a CRC and a payload size indicator at the end of the cell 10 = AAL1 without pointer. Includes a Sequence number packaged with the cell, as well as the possibility of transmitting SRTS on the VC 11 = AAL1 with pointer. Includes a Sequence number packaged with the cell, and the possibility of transmitting SRTS on the VC</p>

Table 22 - Description of the Fields for the TX_SAR Control Structure (continued)

Field	Name of Field	Byte Address Offset /Bits Used	Description of Field
CE	Circuit Emulation	+0/b4:b2	<p>The CE field bits indicate the presence of a multiframing standard used within the VC.</p> <p>The multiframing standard changes the way the information is read from the TDM circular buffers, as well as the standard that is used to generate the p-byte. In addition, setting the CE bits to a CAS setting will indicate to the TX_SAR that CAS signaling bits must be inserted at the end of the AAL1 control structure.</p> <p>The field bits are decoded as follows:</p> <p>000 = No CAS, no multiframe 001 = Reserved 01x = Reserved 100 = T1 without CAS (T1 type circular buffer, but no CAS will be sent in the ATM cells) 101 = T1 with CAS (T1 type circular buffer, with CAS sent in the ATM cells) 110 = E1 without CAS (E1 type circular buffer, but no CAS will be sent in ATM cells) 111 = E1 with CAS (E1 type circular buffer, with CAS sent in the ATM cells)</p>
BS	TX/RX Circular Buffer Size	+0/b1:b0	<p>These bits encode the size of the TDM circular buffer that is to be read from. In T1 and E1 modes, a portion of space in the circular buffer is required to store the CAS values; in the T1 mode 25% is required, and in the E1 mode 50% is required. Half of the TDM circular buffer is used for TX data and half for RX data.</p> <p>The field bits are decoded as follows:</p> <p>00 = 128 words 01 = 256 words 10 = 512 words 11 = 1024 words</p>
Last Entry	Last Entry	+2/b15:b4	Last Entry is the word offset from the 8 kB boundary containing the structure to the last circular buffer pointer in the structure.
TXD	TX_SAR Destination Field	+2/b3:b0	<p>The TXD field is used to tell the UTOPIA Module the destination of the assembled ATM cell.</p> <p>The TX_SAR Destination field is decoded as follows:</p> <p>0000 = Discard ATM cell 0XX1 = Send to TXA port 0X1X = Send to TXB port 01XX = Send to TXC port Others = Reserved</p> <p>Broadcasting to multiple ports is allowed.</p>

Table 22 - Description of the Fields for the TX_SAR Control Structure (continued)

Field	Name of Field	Byte Address Offset /Bits Used	Description of Field
Payload Size	Payload Size	+4/b15:b10	For fully-filled cells, regardless of type, the payload size field is 30h. For partially-filled cells, the payload size indicates the number of TDM bytes to be placed in each ATM cell. The field range is from 4h to 2Fh. <u>Note:</u> 2Fh is an illegal value for partially-filled AAL1 cells For partially-filled AAL5 VTOA, this field must be set to 8h, 10h, 18h, 20h, or 28h.
Offset	Offset	+4/b9:b3	Offset is used when the VC first starts up, and whenever an event with the S bit is set in the transmit event scheduler entry. This shows the delta that must exist between the TX_SAR read pointer and the TDM write pointer within the circular buffer. The value for this offset will change depending on the number of channels in the VC, and on the multiframing standard used. Offset's value is programmed with the maximum number of bytes of a given channel in an ATM cell, plus three. If an error is produced when programming Offset, a global tx_slip will be flagged in the register 0502h, indicating an erroneous configuration and the possibility of corrupted data. The Offset between the tx_wrt_pnt (TDM) and the tx_sar_read_pnt that must be present prior to assembling any ATM cell whose event in the transmit event scheduler has the S bit set. This offset is coded as an integer from normal VCs. It is coded as an multi-frame [1:0] and frame [4:0] number for E1 and T1 VCs.
GFC, VPI, VCI, OAM, PTI, CLP	Header information	+8, +A/b15:b0	Header information for the cells to be assembled using this TX_SAR control structure.
P-Byte Counter	P-Byte Counter	+C/b14:b0	The p-byte counter field is used for the generation of the p-byte within the cell, or within the multiframe structure. The p-byte counter is decremented each time a byte of data is sent, including a CAS byte, but not including an information byte such as the AAL1 byte or the pointer-byte. Whenever the counter reaches 0 and must decrement, its value is reset to p-byte Max field which must be set to 0 by the software. Whenever a p-byte needs to be generated, the seven LSBs of the P-byte Counter are the value of the p-byte, with parity added as the MSB. The decrementing continues until the value of the P-byte Counter reaches 0 and wraps around again, ending the multiframe and beginning a new one.

Table 22 - Description of the Fields for the TX_SAR Control Structure (continued)

Field	Name of Field	Byte Address Offset /Bits Used	Description of Field
Current Entry	Current Entry	+E/b15:b4	The Current Entry field tells the SAR what the first channel is to be assembled in this cell. The valid values for this field are contained between the First Entry and the Last Entry fields inclusively. The Current Entry field also points to words, and is initialised by software to the word pointed to by the First Entry field. The Current Entry field is similar the Last Entry field, such that it is defined as the offset between the Current Entry field and the 8 kB boundary in which the structure is contained.
I	Structure Initialised Bit	+E/b3	The I bit is set by the hardware when a scheduler entry flagged with the Start bit asserted high is encountered, i.e., as soon as the first cell is sent on this VC. This bit is cleared by the software upon initialisation.
Seq	AAL1 Sequence Number	+E/b3:b0	These bits are reset by software.
tx_sar_read_pnt	Tx_sar_read_pnt	+10/b15:b6	This value is a pointer to the next byte to be read in the TX/RX Circular Buffers.
Transmitted Cell Counter	Free running transmitted cell counter	+12, +14/b15:b0	The Transmitted Cell Counter increments each time a cell is transmitted on the VC. The time needed for the counter to wrap-around decreases proportionately with the number of channels in the VC. This field should be reset by software and is used for monitoring.
V	TDM Channel Valid	+16 to end/b15	When this bit is high the channel is active. When this bit is '0', the programmable null byte, found in register 0420h, will be transmitted.
Channel N's TX/RX Circular Buffer Pointer	Channel N's TX/RX Circular Buffer Pointer	+16 to end/b13:b0	This field is a pointer to the TX/RX Circular Buffer associated with this channel. "0000 0000" will be appended to this field as the LSBs to form a 22-bit address in data memory.

Table 22 - Description of the Fields for the TX_SAR Control Structure (continued)

4.3.6 Miscellaneous TX_SAR Features

4.3.6.1 T1 with CAS and E1 with CAS Cell Format Mapping

For the transmission of T1 with CAS and E1 with CAS, the number of frames required is 9000 and 6000 respectively. But, because the number of frames mapped in a full size transmit event scheduler is always a multiple of eight, the MT90503 handles large size schedulers by dividing the size by eight, and mapping eight times less events (1125 for T1 with CAS and 750 for E1 with CAS). This results in a latency of one frame.

4.3.6.2 Support of Partially-Filled Cells

The MT90503 is capable of supporting partially-filled cells, as long as the number of channels in the VC is smaller or equal to the cell fill. A single transmit event scheduler can be created to accommodate several sizes of AAL1, CBR-AAL0 or AAL5-VTOA ATM cells. AAL1 with pointer ATM cells can be used by this format, since the number of data bytes per ATM cell is always constant. For example, the 240-entry transmit event scheduler is capable of accommodating partially-filled cells of 4-, 5-, 6-, 8-, 10-, 12-, 15-, 16-, 20-, 24-, 30-, or 40-bytes per cell.

4.3.6.3 TX_SAR FIFO

The TX_SAR transmits cells contained in its data cell FIFO when there are no events to be processed. The TX_SAR's data FIFO can be used to store AAL0 cells as well as OAM cells, therefore, CPU-based OAM cell generation is supported.

4.4 RX_SAR Module

The RX_SAR module performs processing on ATM cells received from the UTOPIA module. Cells placed in the RX_SAR input FIFO by the UTOPIA module are read, processed, and then written into the appropriate multi-cell circular buffer in external control memory. The processing involves identifying the VC corresponding to the cell, examining the cell for errors, determining where to place the data, and monitoring the status of circular buffers. The RX_SAR module also directs data cells to the data cell FIFO from which the CPU can read them.

The RX_SAR module does not connect to any external pins, interfacing instead with the UTOPIA module, CPU interface, and external memory controller. Global pointers are shared between the RX_SAR and TDM modules.

ATM cells that are received by the MT90503 are processed by the UTOPIA module and can be directed to any of three TX output FIFOs or to the 32-cell RX_SAR input FIFO. Those cells that are forwarded to the RX_SAR are directed to the SAR portion (cells to be formatted into TDM streams), to the data cell portion (to be examined by the CPU), or to both.

For cells directed to the SAR portion, the RX_SAR uses control information in the RX_SAR Control Structures (Section 4.4.2) to extract the payload data from the received cell and store it into TDM channel RX Circular Buffers located in external data memory.

4.4.1 Treatment of Data Cells

Data cells, such as those containing OAM information, are placed in a programmable length FIFO in external control memory. The length of the FIFO is stored in register 070Eh. The CPU can read a data cell at any time, after obtaining the address of the FIFO (register 070Ch) and the read pointer (register 0708h).

The CPU can be alerted to the presence of data cells via an interrupt that triggers if either of two events occur: the interrupt can be generated when the FIFO becomes more than half full or the interrupt can be generated if a data cell has been present in the FIFO for longer than a programmable period of time (registers 0720h, 0722h). This interrupt can be enabled through register 0220h.

When ready to process the information, the CPU obtains a read pointer to the information from register 0708h and reads the information through 26 word accesses.

Cells with the OAM bit set in the PTI portion of the header can be directed to the data cell FIFO on a per VC basis. The same is true for non-OAM cells. In addition, unknown non-OAM cells, and/or unknown OAM cells can also be sent to the data cell FIFO (all unknown non-OAM cells are directed to the same location(s)).

4.4.2 Control Structure

For each VC directed to the SAR portion of the RX_SAR, an RX_SAR control structure exists in external control memory. The structure, similar to that of the TX_SAR, contains information on how to process a cell including:

- what type of traffic is being carried (AAL1, CBR-AAL0, AAL5-VTOA)

- the size of the circular buffers for the data
- how to act in the case of an overrun or underrun
- the multiframing standard in place
- expected presence of CAS
- enabled errors, the size of the payloads
- information necessary to detect and correct for errors
- a pointer to each circular buffer, one for each channel in the VC

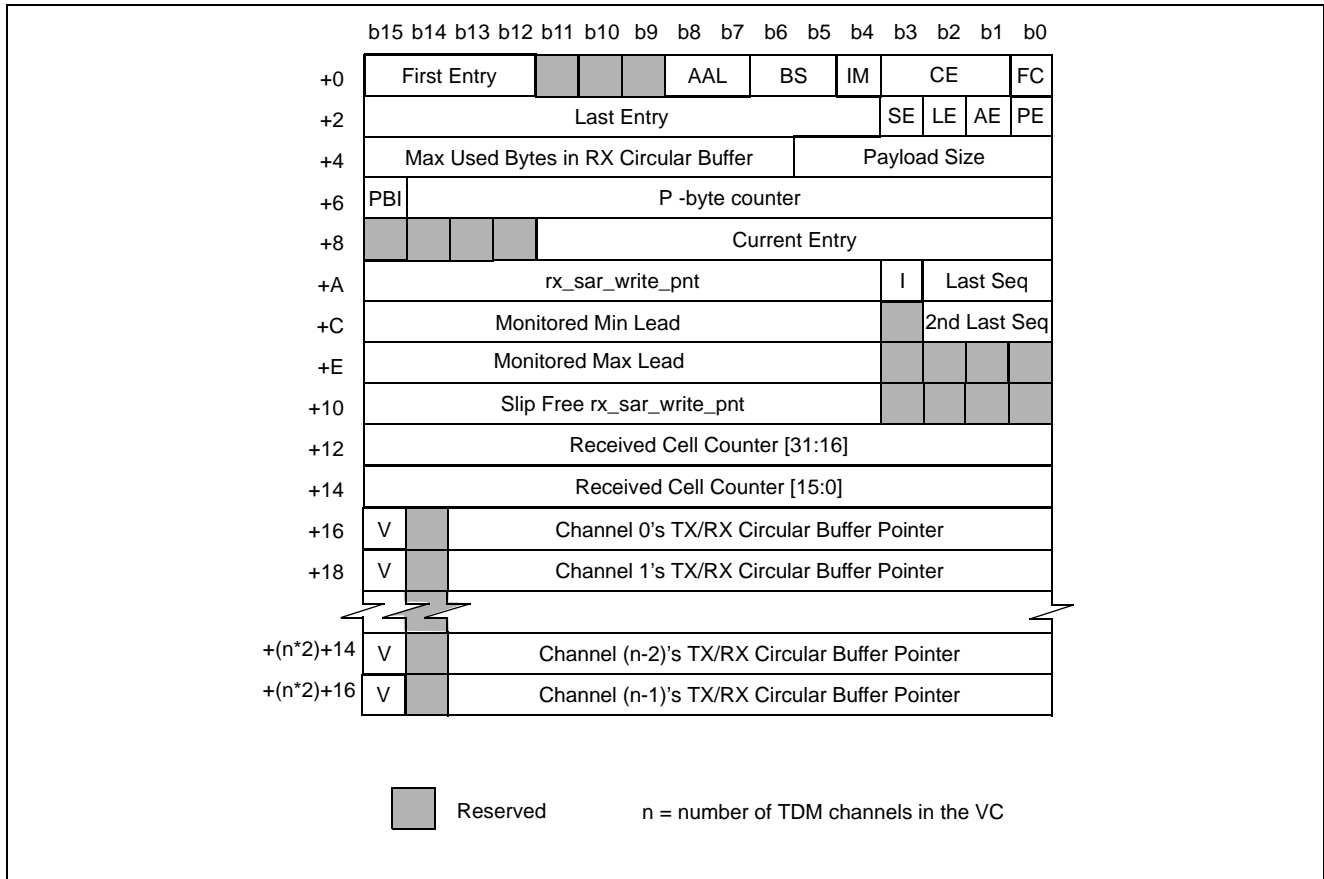

Figure 30 - RX_SAR Control Structure

Field	Name of Field	Byte Address Offset/Bits Used	Description of Field
First Entry	First Entry	+0/b15:b12	First entry field gives the position within the structure of the pointer to the first channel. The field is a word pointer and is constant with a value of 0xB. To allow for future structure updates, its value is programmable. Channel 0's address is located at base_add + (2 * First Entry).

Table 23 - Description of the Fields for the RX_SAR Structure

Field	Name of Field	Byte Address Offset/Bits Used	Description of Field
AAL	Adaptation Layer	+0/b8:b7	The AAL bits indicates the ATM format used to assemble the cells in this structure. The AAL bits are decoded as follows: 00 = CBR AAL0 01 = AAL5-VTOA 10 = AAL1 without pointer 11 = AAL1 with pointer
BS	TX/RX Circular Buffer Size	+0/b6:b5	These bits encode the size of the entire TX/RX circular buffer that is to be written into. In T1 and E1 modes, a certain portion of the space in the buffer is required to store the CAS values; in the T1 mode 25% is required and in the E1 mode 50% is required. The eight MSBs of each word in the TX/RX Circular buffer are used for TX data and the remaining 8 bits for RX data. These bits are decoded as follows: 00 = 128 words 01 = 256 words 10 = 512 words 11 = 1024 words
IM	Initialisation Method	+0/b4	Initialisation method for rx_sar_write_pnt '0' = initialise rx_sar_write_pnt to nearest boundary: either tdm_read_pnt + (Max used bytes in TX/RX Circular buffer) - 1 OR tdm_read_pnt + 1 '1' = initialise rx_sar_write_pnt to (Max used bytes in TX/RX Circular buffer)/2 This initialisation method will be used when the first cell is received and each time a slip (an overrun or underrun) occurs.
CE	Circuit Emulation	+0/b3:b1	The circuit emulation bits indicate the multiframing standard used within the VC. These bits are decoded as follows: 000 = No CAS, no multiframe 001 = Reserved 01x = Reserved 100 = T1 without CAS 101 = T1 with CAS 110 = E1 without CAS 111 = E1 with CAS
FC	FASTCAS Enable	+0/b0	FASTCAS is enabled when FC is asserted high. If FASTCAS is used, then the receive pointer used for regular TDM bytes and for CAS bytes is not the same. CAS is written one multiframe before TDM bytes in FASTCAS. When FC is deasserted, regular multiframing is employed: CAS is written in the same multiframe as TDM bytes.
Last Entry	Last Entry	+2/b15:b4	Last Entry is the word offset from the 8 kB boundary containing the structure to the last circular buffer pointer in the structure.
SE	Slip Error Report Enable	+2/b3	When set, overrun and underrun slips will generate an RX_SAR Error Report Structure (Figure 32) in the error FIFO in control memory.

Table 23 - Description of the Fields for the RX_SAR Structure (continued)

Field	Name of Field	Byte Address Offset/Bits Used	Description of Field
LE	Cell Loss and Insertion Error Report Enable	+2/b2	When set, single cell losses, multiple cell losses and cell misinsertions will generate an RX_SAR Error Report Structure (Figure 32) in the error FIFO in control memory.
AE	AAL1 Byte Report Enable	+2/b1	When set, AAL1 CRC-3 and CRC-3/Seq Num parity errors will generate an RX_SAR Error Report Structure (Figure 32) in the error FIFO in control memory.
PE	P-Byte Error Report Enable	+2/b0	When set, p-byte parity errors, p-byte absent and p-byte framing errors will generate an RX_SAR Error Report Structure (Figure 32) in the error FIFO in external control memory.
Max Used Bytes in RX Circular Buffer	Max Used Bytes in RX Circular Buffer	+4/b15:b6	This field indicates the range of valid positions in bytes of the rx_sar_write_pnt relative to the tdm_rx_read_pnt before a cell is received. In no case can this value be 0.
Payload Size	Payload Size	+4/b5:b0	For fully-filled cells, regardless of type, the payload size field is 30h. For partially-filled cells, the payload size indicates the number of TDM bytes in each ATM cell. The field range is from 4h to 2Fh. <u>Note:</u> 2Fh is an illegal value for partially-filled AAL1 cells For partially-filled AAL5 VTOA, this field must be set to 8h, 10h, 18h, 20h, or 28h.
PBI	P-Byte Initialization	+6/b15	Initialized to '0' by software.
P-Byte Counter	P-Byte Counter	+6/b14:b0	This field is a counter used to detect p-byte framing errors. When a p-byte is detected, this counter is loaded with the p-byte's value. Each time a TDM byte is received, the counter is decremented. When the counter reaches the Current Entry it should be reset to the First Entry and the rx_sar_write_pnt should point to the beginning of the multiframe if applicable. When it decrements below 0, the counter resets to its maximum. Any time a p-byte is received, its value should match the value in this field, or a p-byte framing error will be detected.
Current Entry	Current Entry	+8/b11:b0	Current Entry indicates which TDM channel the RX_SAR is currently writing to the circular buffers. The current entry is defined as being the offset from the 8 KB boundary containing the structure and the "TX/RX Circular Buffer Pointer" being read from the structure. Current Entry is initialised to the value of First Entry, increments up to Last Entry, and then wraps around to First Entry. This field should be initialised by software to 0Bh. <u>Note:</u> This field should not be written to while the VC is active.

Table 23 - Description of the Fields for the RX_SAR Structure (continued)

Field	Name of Field	Byte Address Offset/Bits Used	Description of Field
rx_sar_write_pnt	RX_SAR write pointer	+A/b15:b4	This is a pointer to the location where the next byte will be written in each TX/RX Circular Buffer. It is common to all TX/RX Circular buffers controlled by the RX_SAR Control Structure. In the E1/T1 mode, this field is divided in multiframe [6:0] and frame[4:0]. Only the lower part of the field is used to point to the TX/RX Circular Buffer.
I	Structure Initialised Bit	+A/b3	This bit must be reset by software before enabling the VC in the LUT. The bit is set by hardware after receiving the first cell.
Last Seq	Last Seq	+A/b2:b0	Last received AAL1 sequence number.
2 nd Last Seq	2 nd Last Seq	+C/b2:b0	Second-last received AAL1 sequence number.
Slip Free rx_sar_write_pnt	Slip-free RX_SAR write pointer	+10/b15:b4	The Slip-free rx_sar_write_pnt is the same as the rx_sar_write_pnt except that slips (overruns and underruns) do not affect its value.
Received Cell Counter	Received Cell Counter	+12/b15:b0 +14/b15:b0	A 32-bit free running cell counter used for monitoring activity on a VC and for statistical purposes. This field can be initialised to '0' by software.
V	TDM Channel Valid	+16 to end/b15	When this bit is high the channel is active. When this bit is reset, all received bytes on the channel are discarded.
Channel N's TX/RX Circular Buffer Pointer	Channel N's TX/RX Circular Buffer Pointer	+16 to end/b13:b0	This field is a pointer to the TX/RX Circular Buffer associated with this channel. "0000 0000" will be appended to this field as the LSBs to form a 22-bit address in external data memory.

Table 23 - Description of the Fields for the RX_SAR Structure (continued)

Memory containing the control structures is divided into 8 KB blocks. Zero or more control structures can exist in a block. Control structures must be fully contained in a single block. The pointers Current Entry and Last Entry are relative to the 8 KB block boundary in which their structure resides.

The Buffer Size (BS) field indicates the size of the Receive Circular Buffers. Though the Buffer Size is indicated in words, the received data occupies only the lower byte of each word; the data to be transmitted occupies the upper bytes. Selection of size: 128, 256, 512, or 1024 words, depends on the amount of available memory and on the CDV for the VC. The receive half of the buffer must be capable of holding twice the maximum CDV (peak CDV) plus the packetisation size of the cells in the VC plus two additional bytes. Additional space must be added if E1 or T1 formats are employed (the buffer must be twice as big for E1 and a 4/3 of the size for T1). To convert the maximum CDV from ms into bytes, a data rate of 8000 bytes/s must be applied. The packetisation size is defined as the maximum number of bytes a channel can contain in a single cell of the VC.

To find the maximum CDV supported by the buffer, the value of the "Max Used Bytes In Circular Buffer" field must be divided by two and multiplied by 125 μ s/byte. Because a larger buffer will cause more delay through the RX_SAR, the choice of the value of "Max Used Bytes In Circular Buffer" must be made as a compromise between the CDV supported and the delay inserted by the RX_SAR. In the T1/E1 multiframe mode, the value of "Max Used Bytes In Circular Buffer" must be an integer number of frames and is counted in a multiframe/frame fashion. The

five MSBs select a number of multiframes and the five LSBs a number of frames. In strict muliframing, the five LSBs are always set to '00000'; they can be any value in FASTCAS.

Setting the multiframing standard in the circuit emulation (CE) field will change the way the information is read from the TDM circular buffers, as well as the standard that is used to interpret the p-byte. In addition, setting the CE bits to a CAS setting will indicate to the RX_SAR that CAS signalling bits should be expected at the end of the AAL1 structure.

The payload size represents the number of TDM bytes in the cell and does not include pointer or AAL1-bytes.

Format	TDM Bytes	Bytes Transmitted	Payload Size
AAL1 with pointer, non-p-type cell	16	17	16
AAL1 with pointer, p-type cell	16	18	16
CBR-AAL0	16	16	16

Table 24 - Payload Sizes for Various Cell Formats

4.4.3 Errors

Category	Error	Coverage	Example
AAL1 Byte	CRC error	AAL1 cells	
	CRC/Sequence Number Parity error	AAL1 cells	CSI = 1, CRC = 010, Seq. num = 110, parity bit = 1. Even parity not observed: a parity error has occurred.
Cell loss/misinsertion	Single cell loss	AAL1 cells	Sequence numbers 1, 2, 4 received. Cell 3 has been lost
	cell misinsertion	AAL1 cells	Sequence numbers 1, 2, 4, 3 received. A cell misinsertion has occurred
	Multiple cell loss	AAL1 cells	Sequence numbers 1, 2, 5 received. Cells 3, 4 have been lost.
P-byte errors	P-byte parity error	AAL1 cells	P-byte = 0100110, parity bit = 0. Even parity not observed: a p-byte parity error has occurred
	P-byte out-of-range	AAL1 cells	P-byte received = 0x52, Structure length for that VC = 0x18. P-byte is too large
	P-byte framing error	AAL1 cells	P-byte is 0x15 when 0x17 was expected.
	P-byte absent	AAL1 cells	
Slip errors	Overrun	all cells	See Figure 31.
	Underrun	all cells	See Figure 31.

Table 25 - RX_SAR errors

Within the four categories of errors, there are eleven possible errors. All but slip errors (overruns and underruns) pertain only to AAL1 cells.

For the following errors, the only action taken is the generation of an error report structure (Section 4.4.4):

- CRC errors
- CRC/sequence number parity errors
- multiple cell loss
- p-byte parity

- out-of-range
- framing
- absent errors

It is the responsibility of the CPU and associated software to act upon notification that an error has occurred. The exceptions to this policy are

- single cell loss (a dummy cell is inserted and treated before accepting the received cell; the received cell counter is incremented by only one)
- cell misinsertion (the misinserted cell is discarded and the received cell counter is not incremented)
- overruns (data is lost and read/write pointers are adjusted)
- underruns (bytes are inserted according to information set in registers 0420h and read/write pointers are adjusted).

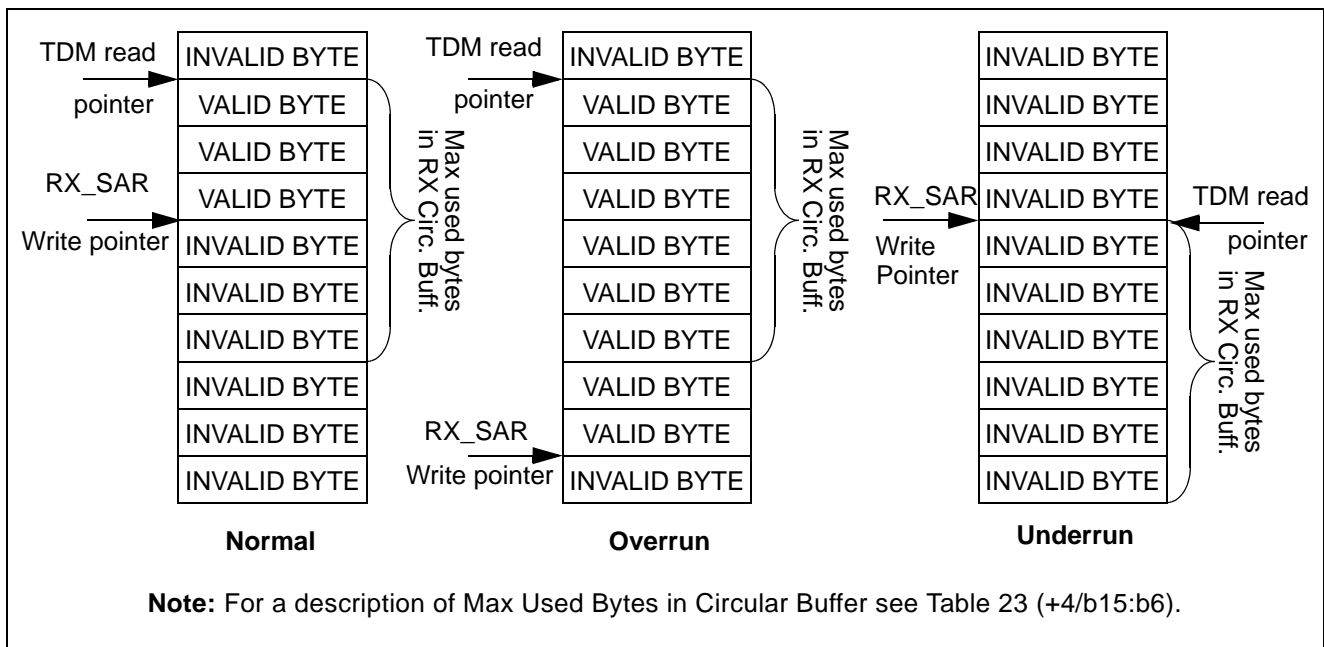

Figure 31 - Overrun and Underrun Examples

4.4.4 Error Report Structure

Four categories of errors can be enabled in the RX_SAR structure:

- slip errors
- cell loss & misinsertion errors
- AAL1 byte errors
- p-byte errors

For each cell containing an error for which the error category is enabled, an 8-byte error report structure is generated and stored in a FIFO in external control memory. From here, the CPU can read the FIFO and treat the errors.

As per the Data Cell FIFO, the CPU can read the error FIFO at any time after obtaining the address to the FIFO (registers 0714h, 0716h) and the read pointer to the RX_SAR Error Report Structure (register 0710h). Again, an interrupt can be generated that will trigger if either of two events occurs: when the FIFO becomes more than half full or if an error report structure has been present in the FIFO for longer than a programmable period of time (register 0724h, 0726h). This interrupt can be enabled in register 0220h.

Errors of more than one type on the same cell will result in one error report structure being created indicating all types of errors on that cell. The exception to this is cell misinsertion. Since the cell is discarded once the misinsertion has been detected, no further errors can be found on the misinserted cell.

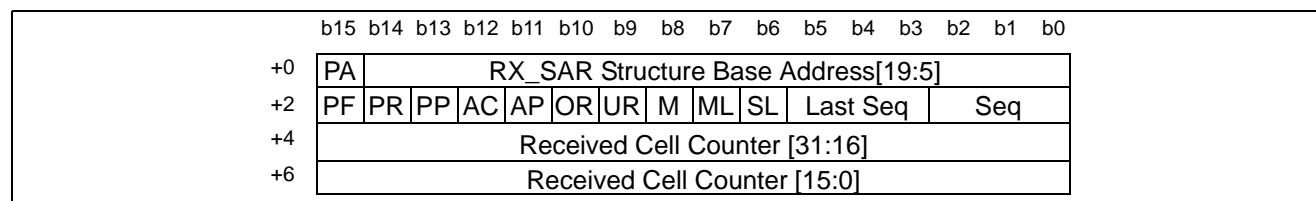

Figure 32 - RX_SAR Error Report Structure

Field	Name of Field	Byte Address Offset/bits Used	Description of Field
RX_SAR Structure Base Address [19:5]	RX_SAR Structure Base Address [19:5]	+0/b14:b0	Base address of the RX_SAR Control Structure that caused the Error Report Structure to be generated. Appended with "00000" as the LSBs to form a 20-bit address.
Seq	Sequence Number	+2/b2:b0	Sequence number of the cell that caused the Error Report Structure to be generated.
Last Seq	Last Sequence Number	+2/b5:b3	Sequence number of the cell which preceded the one that caused the Error Report Structure to be generated.
Received Cell Counter	Received Cell Counter	+4/b15:b0 +6/b15:b0	Cell number of the cell that caused the Error Report Structure to be generated.
PA	P-Byte Absent Error	+0/b15	A p-byte was expected but was not detected in the cell that caused the error.
PF	P-Byte Framing Error	+2/b15	The p-byte that was detected did not match the p-byte that was expected.
PR	P-Byte Range Error	+2/b14	The p-byte that was detected was out-of-range; the 7-bit p-byte must not be 94-126 and must be less than the sequence length of the corresponding VC. 127 signifies a dummy offset value.
PP	P-Byte Parity Error	+2/b13	The p-byte detected did not match its parity bit.
AC	AAL1 Byte CRC-3 Error	+2/b12	There was an error detected in the CRC-3.
AP	AAL1 Byte Parity Error	+2/b11	The AAL1 byte detected did not match its parity bit.

Table 26 - Description of the Fields for the RX_SAR Error Report Structure

OR	Overrun Slip	+2/b10	The circular buffer associated with a channel receiving data from the cell was overrun.
UR	Underrun Slip	+2/b9	The circular buffer associated with a channel receiving data from the cell was underrun.
M	Cell Misinsertion	+2/b8	The sequence number of the cell indicated that a cell was misinserted. This error is always preceded by a single cell loss.
ML	Multiple Cell Loss	+2/b7	The sequence number of the cell indicated that multiple cells were lost.
SL	Single Cell Loss	+2/b6	The sequence number of the cell indicated that a single cell was lost.

Table 26 - Description of the Fields for the RX_SAR Error Report Structure (continued)

4.5 UTOPIA Module

4.5.1 Overview

The purpose of the UTOPIA module is to provide an external interface with the ATM domain. The MT90503 complies with The ATM Forum's specifications: af-phy-0017.000 and af-phy-0039.000. The MT90503 uses octet-level handshaking on its UTOPIA interface.

The UTOPIA module is responsible for accepting cells from four input interfaces, examining the cells and, based on the source and information in the header, sending the cell to one or more of the four output interfaces. The UTOPIA module also calculates and appends the HEC to outgoing ATM cells.

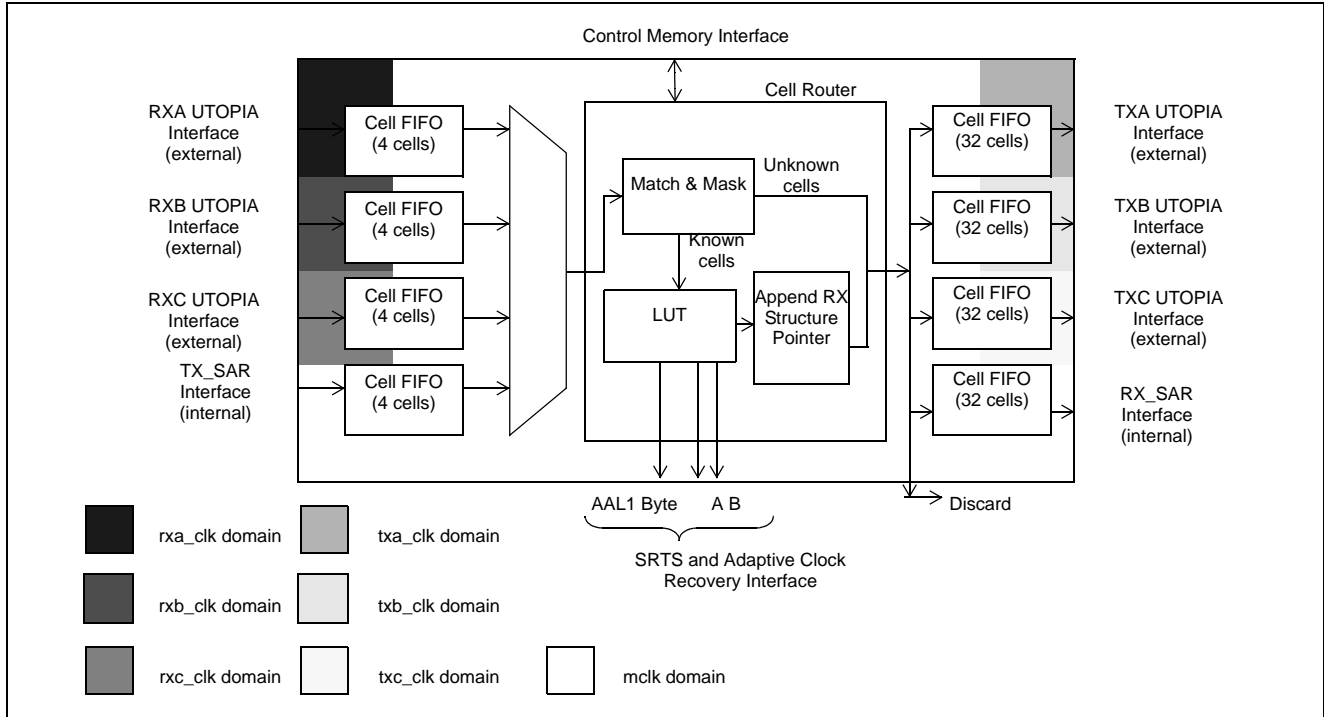

Figure 33 - UTOPIA Module

The UTOPIA interface consists of three ports, labelled A, B, and C. Port A is a Level-2 ATM (single PHY), single PHY or multi-PHY port and can operate at 50 MHz. Port B is a Level-2 ATM (single PHY) or single PHY port and can operate at 50 MHz. It is restricted to an 8-bit data bus when port A is in multi-PHY mode. Port C is a Level-1 ATM or PHY port.

In addition to ports A, B, and C, the UTOPIA accepts cells from the TX_SAR and routes cells to the RX_SAR and to the data cell FIFO in external control memory.

4.5.2 UTOPIA Interfaces

Each of the three ports is divided into two portions: a receive portion and a transmit portion. The TX_SAR and the receive portions are each connected to a 4-cell FIFO. These FIFOs are read on a round-robin basis by the Cell Router (See "Cell Router" on page 82.).

The RX_SAR and the transmit portions are each connected to a 32-cell FIFO.

The ports are configurable with the following options:

- Port A's transmit portion can be ATM, PHY, with a 16-bit or 8-bit data bus.

- Port A's receive portion can be ATM or PHY, with a 16-bit or 8-bit data bus.
- Port A can be Level-2 multi-PHY.
- Port B's transmit portion can be ATM or PHY, with a 16-bit or 8-bit data bus.*
- Port B's receive portion can be ATM or PHY, with a 16-bit or 8-bit data bus.*
- Port C's transmit portion can be ATM or PHY, with an 8-bit data bus.
- Port C's receive portion can be ATM or PHY, with an 8-bit data bus.

*When Port A is in Level-2 multi-PHY mode, Port B must have an 8-bit data bus.

Each receive interface can be independently enabled or disabled. If disabled, the receive interface will stop accepting cells after the current cell has been received.

When the transmit portions of a port are in PHY mode, the SOC, data bus, and parity output pins can be tristated when the port is not selected. This allows the MT90503 to share a data bus, SOC, and parity lines with other devices (i.e. independent ENB signals and CLAV signals for each PHY device, controlled by a single ATM device).

In the case of a receive PHY, the generation of the rx_clav signal is independent of the state machine. The rx_clav signal is asserted high at any time when a complete cell can be received. Thus as soon as the first byte of a cell is received, and there is no room for another cell in the input FIFO, the rx_clav signal will be asserted low. In the case of a Level-2 PHY, the rx_clav's will only be driven when the address was placed on the bus during the previous cycle.

4.5.3 Errors on received cells

If the MT90503 receives a short cell on any one of its three ports, the cell will be discarded, and a new cell will be started when the second SOC signal is set.

If the SOC is not set after the 53rd byte of a received cell, subsequent bytes are ignored until a new SOC is received.

Data received on all of the three ports is examined for parity errors and an interrupt is raised if an error is found. Cells are not discarded if a parity error is detected. Register 0304h indicates on which port the parity error is detected.

The ATM HEC is not examined on received cells.

4.5.4 Transmit and Receive State Machines for ATM and PHY Modes

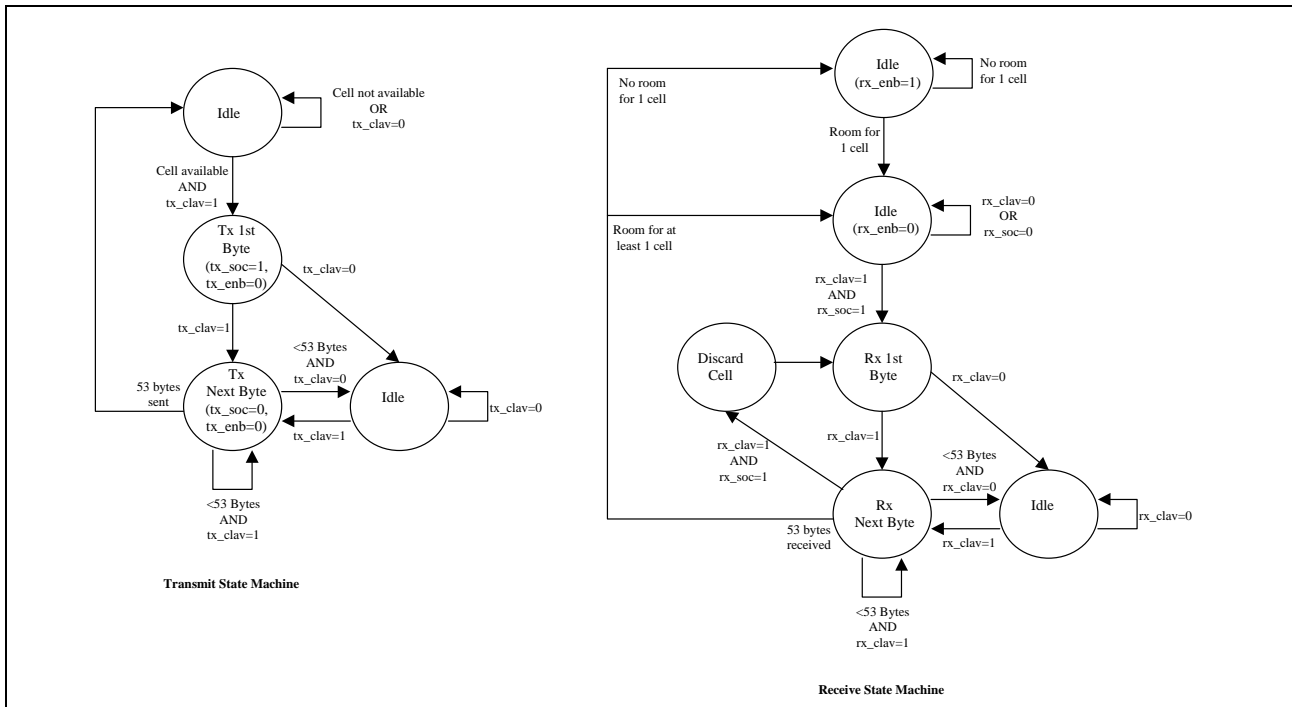
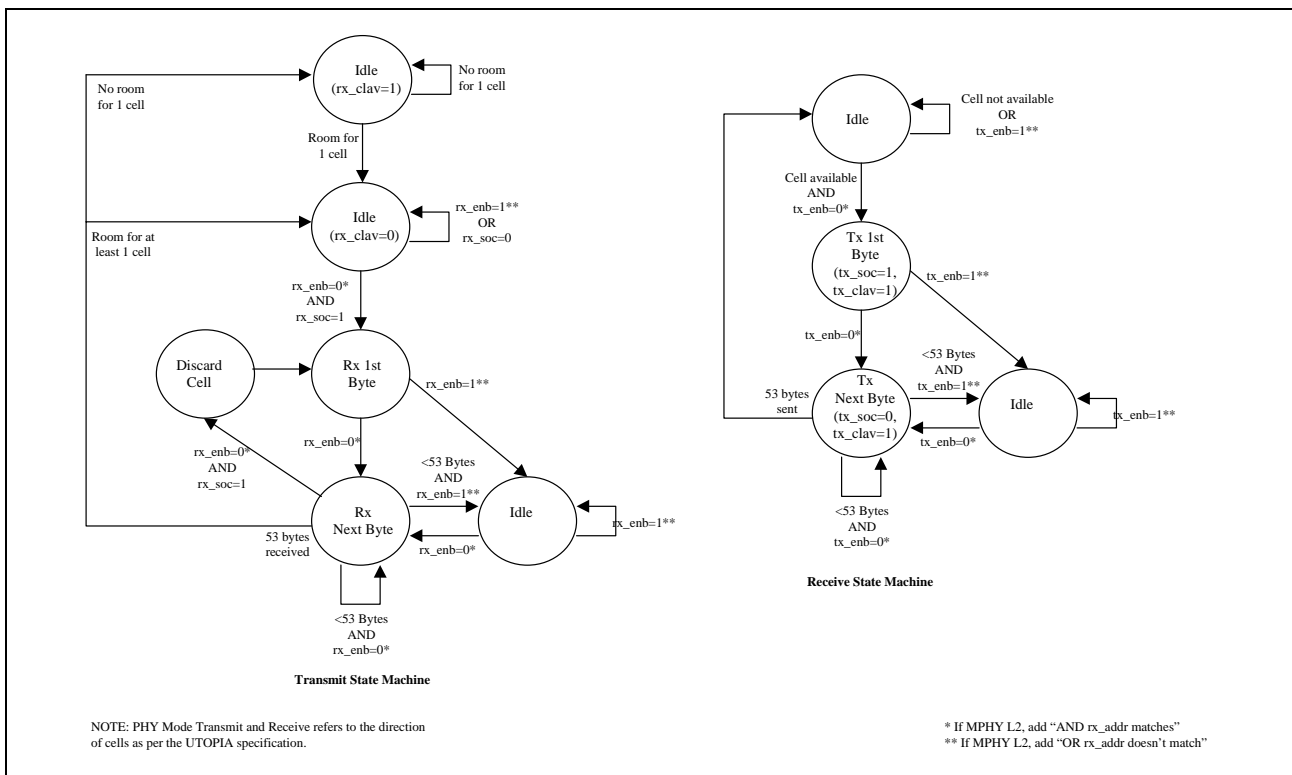

Figure 34 - ATM Mode State Machines



NOTE: PHY Mode Transmit and Receive refers to the direction of cells as per the UTOPIA specification.

* If MPHY L2, add "AND rx_addr matches"
 ** If MPHY L2, add "OR rx_addr doesn't match"

Figure 35 - PHY Mode State Machines

4.5.5 Cell Router

Cells are read on a round-robin basis from the four input FIFOs. Cells from the TX_SAR that contain a '0' in the MSB of the TXD field (see Figure 36 on page 82) are written into the output FIFOs designated by the three LSBs of the TXD field. Cells from the TX_SAR that contain a '1' in the MSB of the TXD field and cells from the RXA, RXB, and RXC ports are handled based on the VPI/VCI of the cell. The TXD field for a cell is the same as the TXD field in the TX_SAR control structure that created the cell (see Figure 29 on page 65).

Cells written into the RX_SAR output FIFO can be directed to the SAR portion (cells to be formatted into TDM streams), to the data cell portion (to be examined by the CPU), or to both. This is indicated by the RXD field in cells written into the RX_SAR output FIFO.

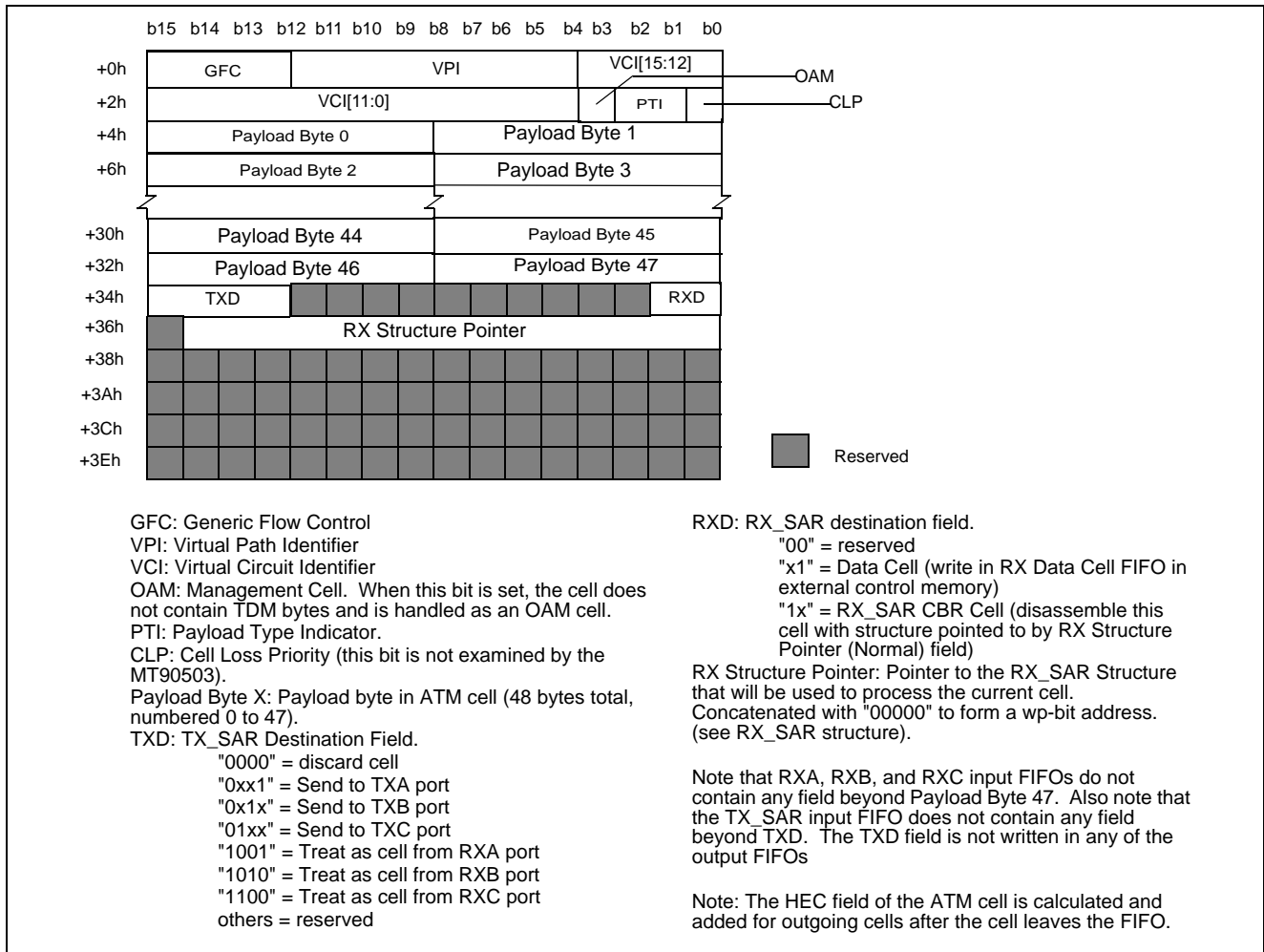

Figure 36 - Cell Format for cells in internal UTOPIA input and output cell FIFOs

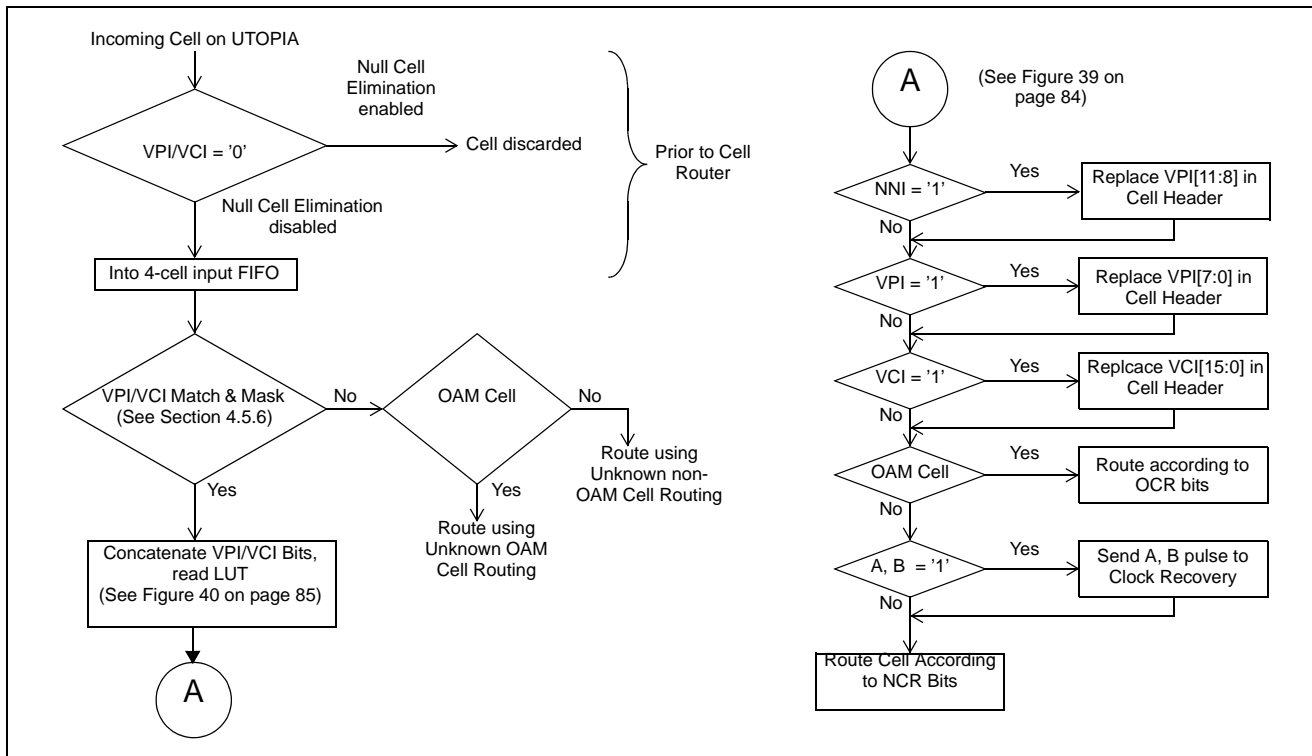

Figure 37 - Cell Router Flow

4.5.6 Match & Mask for cell routing

Cells are designated as "known" or "unknown" based on the result of a match & mask (configurable for each port). For a cell to be considered "known" all VPI/VCI bits whose corresponding mask bit is '1' must have the value contained in the corresponding bit of the match register. The match and mask registers for Port A are 0328h, 032Ah, 032Ch and 032Eh. Likewise the match and mask register for Port B are 0342h, 0344h, 0348h and 034Ah. For Port C, the registers are 0368h, 036Ah, 036Ch and 036Eh.

GFC VPI VCI (from cell header)	0010 10000000 00000000 10110010	0010 10000000 00000000 10110110
Match Value	0000 00000000 00000000 10110010	0000 00000000 00000000 10110010
Match Result (1 = Mismatch)	0010 10000000 00000000 00000000	0010 10000000 00000000 00000100
Mask Value	0000 00111111 00000000 11111111	0000 00111111 00000000 11111111
Mask Result (1 = mismatched cell)	0000 00000000 00000000 00000000	0000 00000000 00000000 00000100
Result	Routed according to LUT entry	Routed as unknown cell

For each bit, result = (match XOR header) AND mask

Figure 38 - Match & Mask Example

In addition, the Cell Router can be configured to eliminate null cells (those with VPI = 0 and VCI = 0). For the purpose of null cell elimination, the NNI can be included on a per-port basis (see registers 0300h and 0302h).

Unknown non-OAM cells and/or unknown OAM cells can be discarded or directed to one or more output FIFOs. All unknown non-OAM cells from a port are discarded or directed to the same location(s) and all unknown OAM cells from a port are discarded or directed to the same location(s). Unknown cells can be directed differently for each port on which they were received. Unknown cells cannot be sent to the SAR portion of the RX_SAR. The routing of unknown cells is set in registers 03A2h and 03A4h.

Known cells are handled according to the LUT (Look-Up Table) entry for the cell's VPI/VCI.

4.5.6.1 Look-Up Tables Entries

LUT entries direct cells with known VPI/VCI to either be discarded or placed in one or more of five possible destinations: the four output FIFOs and the data cell FIFO in external control memory, by way of the RX_SAR FIFO. OAM cells can be directed independently of non-OAM cells with the same VPI/VCI. OAM cells cannot be directed to the SAR portion of the RX_SAR.

LUT entries can be either 4- or 8-bytes long (short or long LUT entries, set in register 302h). All look-up table entries in all three LUTs are the same size. 8-byte entries are only required if header translation is to be performed for one or more VCs. Cells undergoing header translation have their NNI bits, the remaining VPI bits and/or the VCI bits replaced by the corresponding bits in the LUT entry and are then either discarded or sent to one or more of the possible destinations. VCs that undergo header translation are not directed to the SAR portion of the RX_SAR.

Clock recovery information can be gathered from up to two VCs by setting bit A in one LUT entry and bit B in the same or another LUT entry. A maximum of one VC can have bit A set and a maximum of one VC can have bit B set.

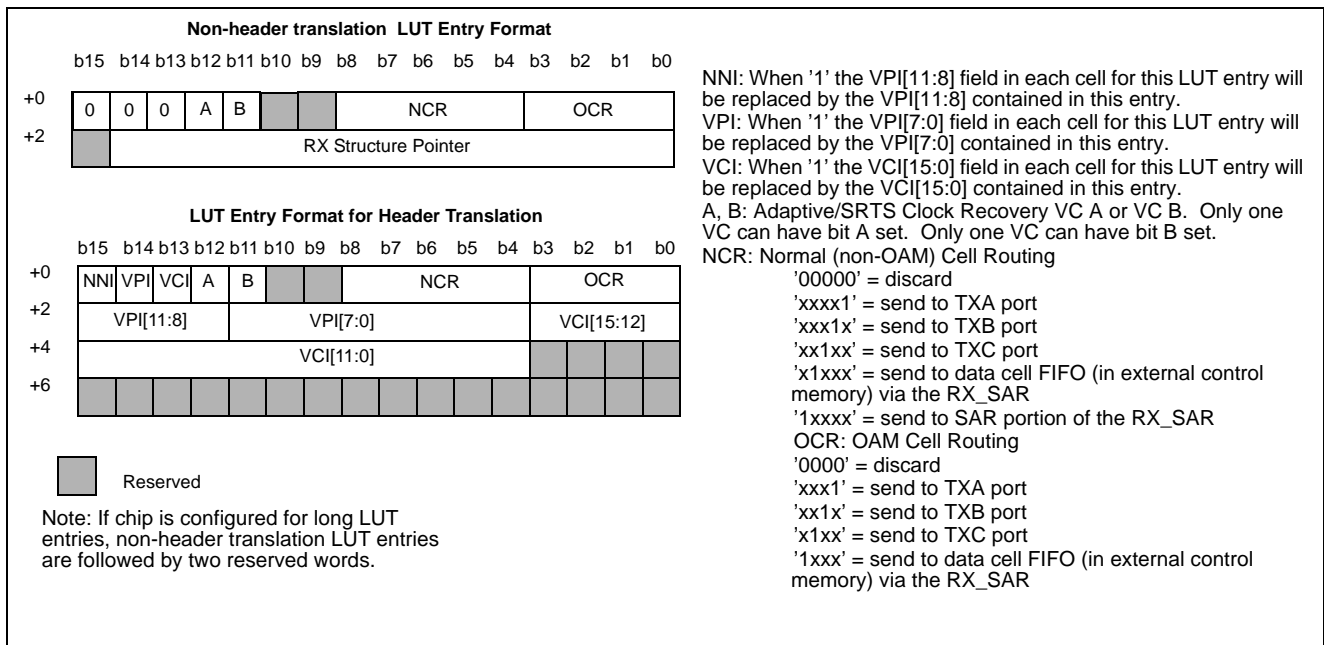

Figure 39 - Short and Long Look-Up Table Entries

4.5.6.2 LUT Addressing

A LUT base address exists for each of the three ports (registers 0320h, 0340h, 0360h). The LUT base addresses for two or more ports can be the same. An identifier for a VC is created by concatenating any number of LSBs from the VPI and LSBs from the VCI, to a maximum of 16 bits. The number of VCI bits used is programmed in registers 0324h, 0344h and 0364h for Port A, B, C respectively. The total number of bits in the identifier is programmed in registers 0322h, 0342h and 0362h for Port A, B and C respectively. The identifier is then appended with either two or three zeros (for either short or long LUT entries).

Finally, this value is used as the byte-pointer to the LUT entry, offset from the LUT base address for that port.

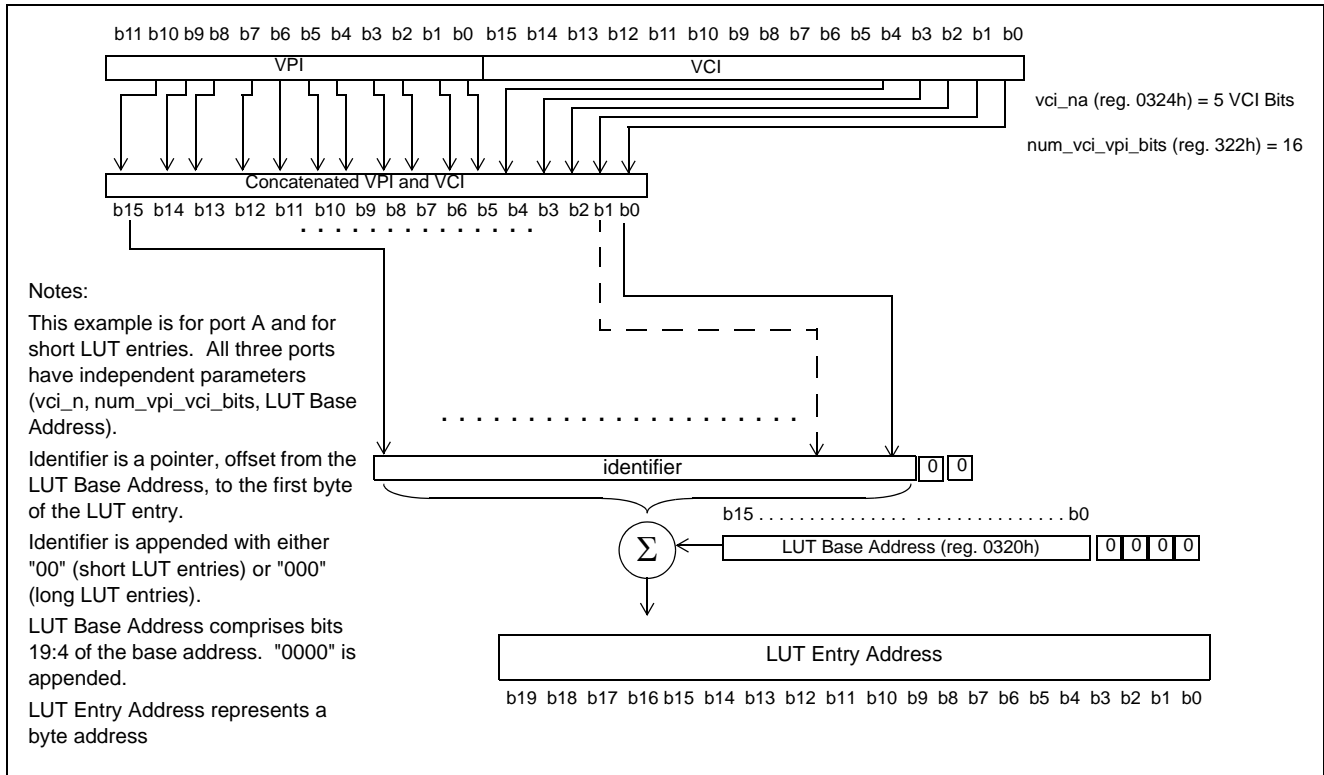

Figure 40 - VPI/VCI Concatenation and LUT Entry Address Example

4.5.6.3 UTOPIA Clocks

Each of the three ports must have a clock to operate the receive interface and a clock to operate the transmit interface. Two or more clocks may have the same source. These clocks can either be input to the MT90503 from an external source or output from the MT90503, from one of three internal UTOPIA clocks. For each port the transmit clock and receive clock must be configured to be either both input or both output. An exception is Port C where both transmit clock and receive clock must be input only.

The source of the each of the three internal UTOPIA clocks can be one of eight clocks: *mclk*, *fast_clk*, or any of the six UTOPIA clocks (*rxa*, *rxb*, *rxc*, *txa*, *txb*, and *txc*). The selected clock is divided by *n*, an integer from 1 to 16, and can be inverted.

Other parts of the UTOPIA module, including the look-up engine, the TX_SAR portion and the RX_SAR portion operate off of *mclk*.

4.5.7 LED Operation

The UTOPIA module generates two LED signals for Port A (pins D2, H5) and two LED signals for Port B (pins W5, T5) in order to indicate the status of the A and B ports. The status conditions are: idle, presence of traffic, or PHY alarm. When a port is in an idle state, both its LEDs are illuminated. If RX traffic (other than null cells) is flowing, then the RX LED for that port will flash; If TX traffic (other than null cells) is flowing, then the TX LED for that port will flash. If a PHY alarm is detected, the TX LED is on and the RX LED is off. The polarity of the LED signals is active-low, i.e., a '0' will turn the LED on. The frequency of the LEDs is programmed in registers 0120h and 0122h while the LEDs are enabled in register 0302h.

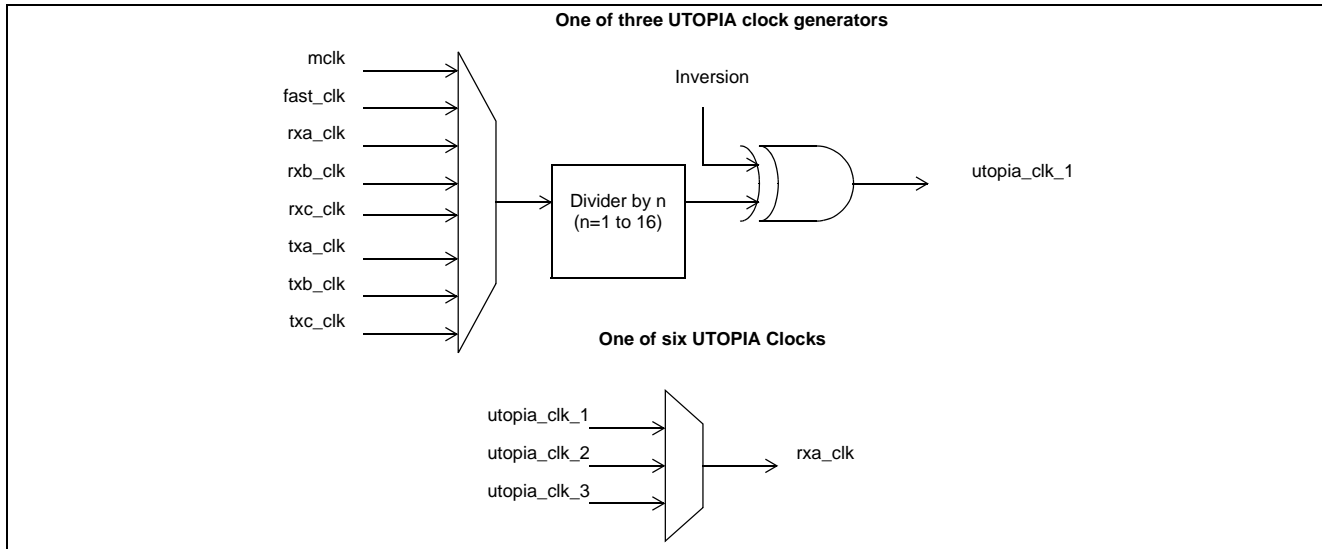

Figure 41 - UTOPIA Clock Generation

4.5.8 UTOPIA Flow Control

The UTOPIA module contains the ability to prevent cells in the 4-cell input FIFOs (RXA, RXB, RXC, and TX_SAR) from being handled by the UTOPIA module in the case that the 32-cell output FIFOs (TXA, TXB, TXC, and RX_SAR) exceed programmable levels.

An input FIFO will be blocked when the level of any output FIFO exceeds the level set for that combination of output FIFO and input FIFO. The levels can be set independently to 1 to 31 cells or to 0, which means no flow control will be exerted (see registers 0338h-033Ah, 0358h-035Ah, 0378h-037Ah). Cell arrival counters and cell departure counters for each port, stored in registers (0330h-0336h, 0350h-0356h, 0370-0376h, 0390-0396h), are used to monitor the fill levels of each output FIFO.

4.5.9 External Interface Signals

Due to the different possible configurations of the UTOPIA ports, the functions of some pins change, depending on the configuration. Some unused data pins when port A and/or port B are in 8-bit mode become general purpose inputs and/or outputs. When Level-2 addressing is in place for port A, portions of the port B data buses are used for as port A addressing pins. The function of the `clav` (cell available) and `enb` (enable data transfer) pins alternate when the port is in ATM mode or PHY mode (Figure 42 on page 87).

Please note that the I/O direction of the pins remains the same.

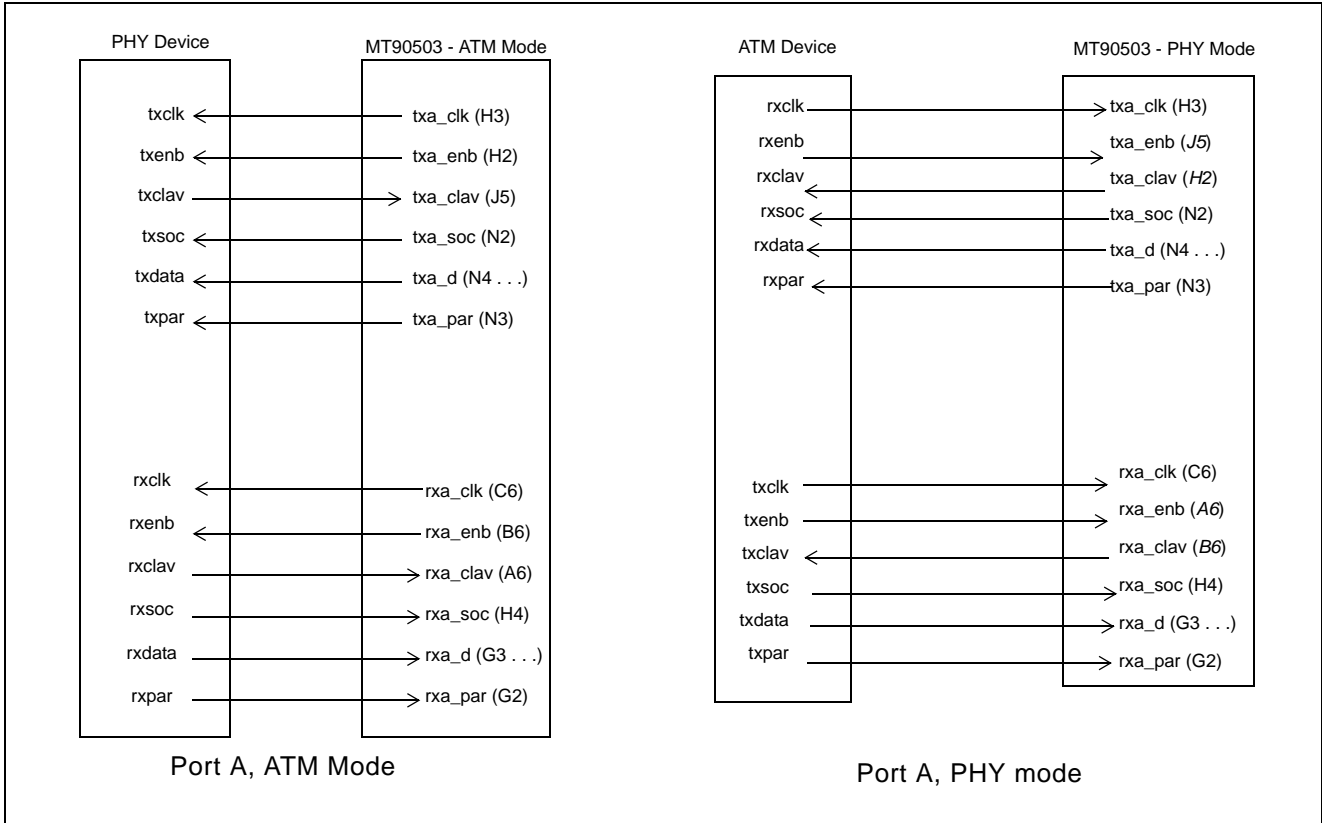

Figure 42 - External UTOPIA Interface

4.6 Clock Recovery Module

4.6.1 Overview

The purpose of the clock recovery module is to synchronise the TDM clock domain of the MT90503 with other devices on the network through information transmitted across the ATM link. Clock recovery is necessary only when the MT90503 is operating as the TDM clock master.

The clock recovery system is composed of several sub-components:

4.6.1.1 Two Point Generation Modules

The point generation modules permit SRTS and/or adaptive clock recovery to be performed by the MT90503. The two modules provide the flexibility to have a back up clock recovery process operating from another VC and/or of the complementary type. These modules generate points which are written to control memory and subsequently used by the clock recovery algorithm.

4.6.1.2 One SRTS (synchronous residual time stamp) Generating Module

The SRTS generating module, is employed to generate the 4-bit outgoing RTS value.

4.6.1.3 Three Integer Divisor Clock Modules

The integer divisor clock (idclk) modules are designed to manipulate any incoming or internal clocks and produce an 8kHz idclk. They provide the flexibility of inverting the clock before or after division, option of setting the duty

cycle to 50%, 16-bit division and checking of the frequency (within a desired range). Along with the idclk_loss signals, idclk's are suited to being sent to an external PLL.

4.6.1.4 Two Precise Clock Modules

The precise clock (pclk) modules are used to divide mclk down to pclk_a and pclk_b. Each module has a pclk_loss indicator which can be employed in tandem with the pclk signal to be routed to an external PLL. The division of mclk is performed with a 16-bit integer and a 16-bit fraction, allowing for precise specification of the pclk frequency. These modules are ideally suited to being programmed by the clock recovery algorithm to generate the recovered clock.

4.6.1.5 Eleven Multiplexers

The 11 multiplexers are: recov_a to recov_h, ct_netref1, ct_netref2 and local_netref_16m. recov_a through recov_h and ct_netrefx are general I/O pins. Local_netref_16m is an internal node, used as the master clock for the TDM section of the MT90503.

4.6.2 Multiplexers

There are eleven multiplexers (see Table 28, "Source Selection," on page 89) with 36 possible inputs each (see Table 29, "idclk_a Register," on page 91):

Signal	Address	Bits
recov_a	0860h	13:8
recov_b	0860h	5:0
recov_c	0862h	13:8
recov_d	0862h	5:0
recov_e	0864h	13:8
recov_f	0864h	5:0
recov_g	0866h	13:8
recov_h	0866h	5:0
ct_netref1	0868h	13:8
ct_netref2	0868h	5:0
local_netref_16m	086Ah	5:0

Table 27 - Multiplexer Registers

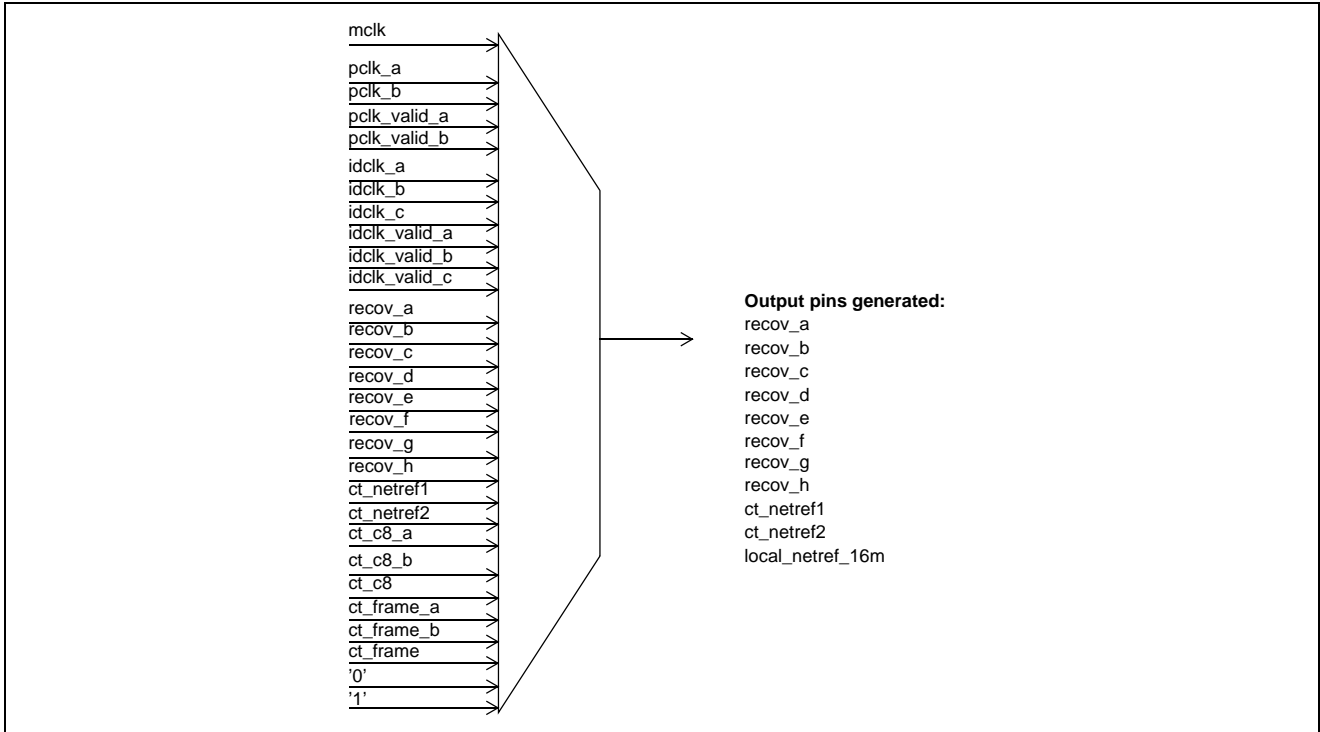

Figure 43 - Multiplexer

Source Select Number	Hex Values	Source	Description
000000	0x00	Logical 0	Ground
000001	0x01	Logical 1	Vcc
000010	0x02	Tri-state	high-impedance
000011	0x03		Reserved
000100	0x04	pclk_a	precise clock
000101	0x05	pclk_valid_a	precise clock valid
000110	0x06	pclk_b	precise clock
000111	0x07	pclk_valid_b	precise clock valid
001000	0x08	idclk_a	integer divisor clock
001001	0x09	idclk_valid_a	integer divisor clock valid
001010	0x0A	idclk_b	integer divisor clock
001011	0x0B	idclk_valid_b	integer divisor clock valid
001100	0x0C	idclk_c	integer divisor clock

Table 28 - Source Selection

Source Select Number	Hex Values	Source	Description
001101	0x0D	idclk_valid_c	integer divisor clock valid
001110	0x0E		Reserved
001111	0x0F		Reserved
010000	0x10	recov_a	external I/O pin
010001	0x11	recov_b	external I/O pin
010010	0x12	recov_c	external I/O pin
010011	0x13	recov_d	external I/O pin
010100	0x14	recov_e	external I/O pin
010101	0x15	recov_f	external I/O pin
010110	0x16	recov_g	external I/O pin
010111	0x17	recov_h	external I/O pin
011000	0x18	ct_c8	active clock: ct_c8_a or _b
011001	0x19	ct_c8_a	TDM clock
011010	0x1A	ct_c8_b	TDM clock
011011	0x1B	ct_frame	active clock: ct_frame_a or _b
011100	0x1C	ct_frame_a	TDM clock
011101	0x1D	ct_frame_b	TDM clock
011110	0x1E	ct_netref1	TDM clock
011111	0x1F	ct_netref2	TDM clock
100000	0x20	ref_vca	cell arrival on VC A
100001	0x21	ref_vcb	cell arrival on VC B
100010	0x22	phy_alm_a	PHY Alarm UTOPIA A
100011	0x23	phy_alm_b	PHY Alarm UTOPIA B
100100	0x24	mclk	master clock

Table 28 - Source Selection (continued)

4.6.3 Integer Divisor Clocks (idclk)

There are three idclk modules in the MT90503. Each module consists primarily of a 16-bit integer clock divider, but also has several clock manipulation circuits. These modules have the ability to flag an interrupt (if enabled - 0884h, 08A4h, 08C4h) if the input frequency is above or below a desired range, invert the clock's polarity (before and after division) and set the percentage duty cycle to 50%. idclk_loss_x signals the loss (or incorrect frequency) of an input synchronisation clock, allowing the clock to easily be output to an external PLL. idclk_a is configured in the register range of 0880h-0894h as described in Table 29.

These modules are ideally suited to dividing down the highly accurate reference clock (f_n) required when performing SRTS clock recovery.

Register	Bits	Name	Description
0880h	[0]	divisor_load_now	set to load new value
0880h	[1]	divisor_reset	0 for reset, 1 for normal operation
0880h	[2]	even_duty_cycle_select	when 1, 50% duty cycle is generated
0880h	[3]	input_invert_select	invert clock before dividing
0880h	[4]	output_invert_select	invert clock after dividing
0880h	[13:8]	input_source_select	see Table 28
0882h	[5:0]		status registers
0884h	[5:0]		interrupt enabling
0886h	[5:0]		manual setting of status registers
0888h	[5:0]	ext_loss_source_select	external output of input clock status. See Table 28.
0888h	[6]	ext_loss_source_polarity	if set to '1', source loss is active high
0888h	[7]	output_loss_polarity	if '1' output loss is active high
088Ah	[15:0]	clk_div	denominator of clock divider
0890h	[15:0]	freqchck_div	denominator of frequency check divider
0892h	[15:0]	freqchck_max_mclk_cycles	max # of mclk's between rising edges of the input clock divided by freqchck_div, if failure occurs, freq_too_low (0882h) will be set.
0894h	[15:0]	freqchck_min_mclk_cycles	min # of mclk's between rising edges of the input clock divided by freqchck_div, if failure occurs, freq_too_high (0882h) will be set.

Note: idclk_b and idclk_c have a corresponding set of registers in the ranges of 08A0h - 08B4h and 08C0h - 08D4h respectively.

Table 29 - idclk_a Register

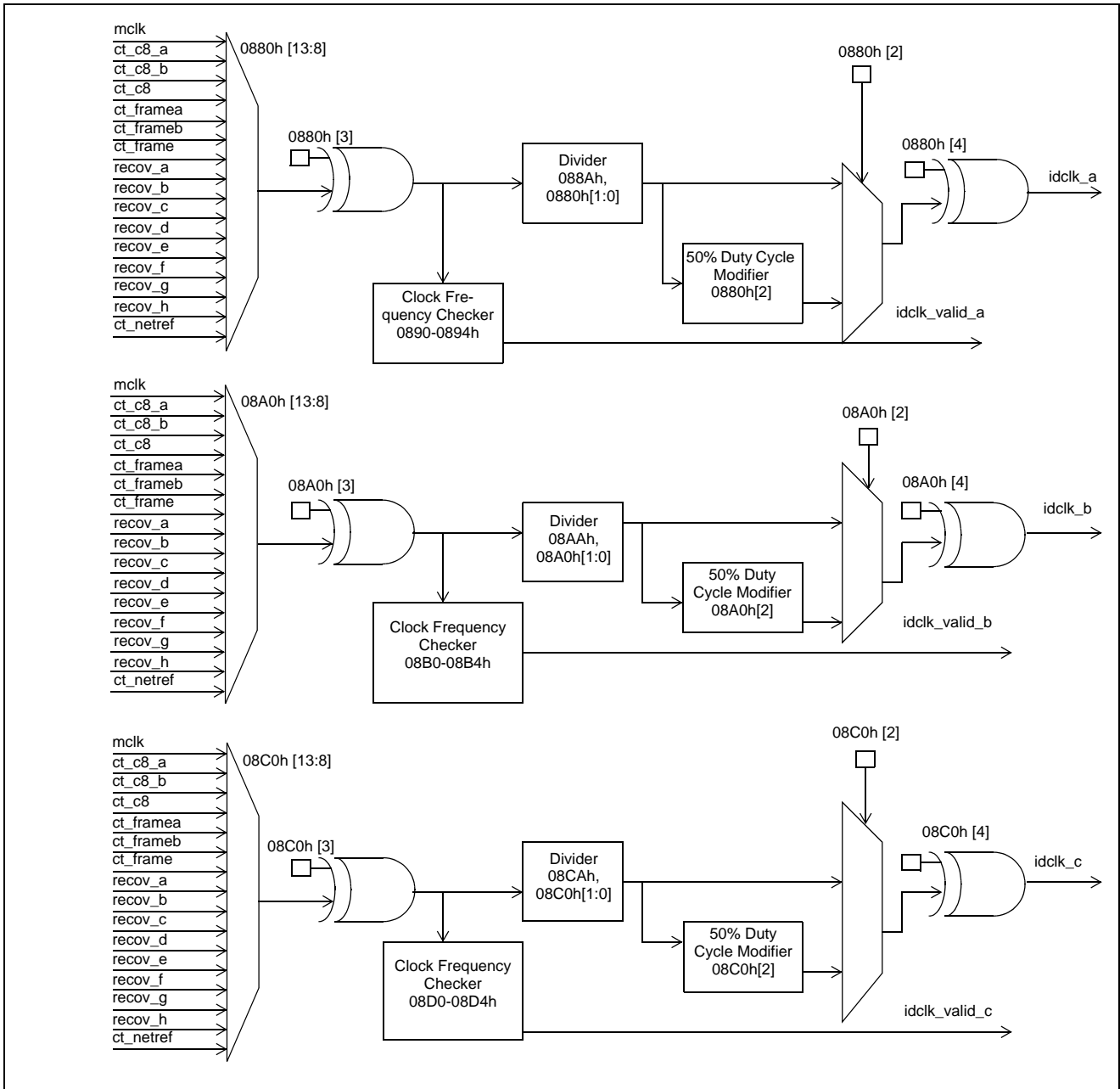

Figure 44 - Integer Clock Processor

4.6.4 Precise Clocks (pclk)

The MT90503 has two digital PLL (pclk) modules. Using mclk as a source, the module will divide it with a 16-bit integer and optional 16-bit fraction. The 16-bit fraction allows more precise specification on the output frequency. Using the optional 16-bit fraction in a typical configuration, mclk = 80MHz, pclk_int_a = 10 000 and pclk_a = 8kHz, will increase the precision from 100 ppm to 1.5 ppm. Also, using the fractional divider will reduce the maximum jitter to one mclk period (12.5ns for 80MHz mclk). Set pclk_frc to 0 if no jitter insertion by the pclk module desired. The divider can be programmed dynamically and has a maximum response time of 125µs.

The following registers are applicable:

Register	Name	Description
0820h[5]	adapsrts0_pclk_loss	indicates state of clock
0820h[6]	adapsrts0_pclk_divisor_load_now	when set, pclk_div and pclk_frc are loaded into digital PLL.
0820h[7]	adapsrts0_pclk_divisor_reset	when '0' digital PLL is in reset state
0830h	adapsrts0_pclk_div	integer divider of pclk_a
0832h	adapsrts0_pclk_frc	fractional divider of pclk_a
0820h[5]	adapsrts1_pclk_loss	indicates state of clock
0840h[6]	adapsrts1_pclk_divisor_load_now	when set, pclk_div and pclk_frc are loaded into digital PLL.
0840h[7]	adapsrts1_pclk_divisor_reset	when '0' digital PLL is in reset state
0850h	adapsrts1_pclk_div	integer divider of pclk_b
0852h	adapsrts1_pclk_frc	fractional divider of pclk_b

Table 30 - pclk registers

The following equation illustrates the derived frequency of pclk from mclk:

$$f_{\text{pclk}} = \frac{f_{\text{mclk}}}{\text{pclk}_{\text{div}} + \frac{\text{pclk}_{\text{frc}}}{65536}}$$

4.6.5 Point Generation

The function of the point generation module is to place points in external memory which have been generated by either the SRTS or Adaptive clock recovery methods. These points express the rates of the master device's TDM clock (through a time stamp or the cell rate), the rate of the slave (performing the clock recovery) device's master clock and the rate of the slave device's pclk. This allows the clock recovery algorithm to evaluate the respective rates and make corrections to the pclk in order to synchronise with the master device.

There are two point generation modules. Each can be configured for SRTS or adaptive clock recovery. The two modules each have a separate point generation process, separate timing reference and each is associated with one pclk module (i.e. pclk_a with adapsrts0 and pclk_b with adapsrts1). This allows switching between clock recovery types and/or sources on the fly. The A and B bits of the UTOPIA look-up table determine which VC generates ref_vca and ref_vcb (see section 4.5.6.1 on page 84).

Register	Bits	Name	Module ¹	Description
0820h	0	adaptive_enable	A	'1' activates adaptive clock recovery
0820h	1	rx_srts_enable	S	'1' activates SRTS clock recovery

Table 31 - adapsrts0 Registers²

Register	Bits	Name	Module ¹	Description
0820h	2	ignore_crc	B	'1' ignores CRC of AAL1 byte
0820h	3	ignore_parity	B	'1' ignores parity bit of AAL1 byte
0820h	4	ignore_seq_num	B	'1' ignores sequence number of AAL1 byte
0822h	0	aal1_crc_error	B	status bit indicating CRC error
0822h	1	aal1_bad_parity	B	status bit indicating parity error
0822h	2	single_cell_lost	B	status bit indicating single cell loss
0822h	3	multi_cell_lost	B	status bit indicating multiple cell loss
0822h	4	cell_misinserted	B	status bit indicating a cell misinsertion error
0822h	5	timeout_flag	B	status bit indicating interval since last cell exceeds time_out_period (0828h) (reset when timeout ceases)
0822h	6	timeout_pulse	B	status bit indicating the interval between two cells has exceeded the time_out_period (0828h)
0822h	7	rx_srts_remote_overflow	S	status bit indicating the interval between remote SRTS values received was too short and one was lost
0822h	8	rx_srts_local_overflow	S	status bit indicating the interval between local SRTS values received was too short and one was lost
0824h	[8:0]			Interrupt Enables
0826h	[5:0]	ref_input_select	A	timing reference (usually ref_vca or ref_vcb), see Table 28.
0826h	[13:8]	rx_fnxi_input_select	S	selects fnxi input, see Table 28.
0828h	[15:0]	time_out_period	B	time-out period between two cells (units - 1024 mclk cycles)
082Ah	[7:0]	adap_pnt_elim_x	A	"keep 1 point out of X" and write to external memory
082Ch	[15:0]	srts8m8c_div_p	S	pclk must be divided by K in order to match the interval of 8 SRTS carrying cells, where $K = P/Q$, P is normally the number of frames in the scheduler, i.e. 375 for fully filled structured AAL1
082Eh	[15:0]	srts8m8c_div_q	S	Q is the number of channels open

Table 31 - adaprts0 Registers² (continued)

1. adaptive relevant register, S - SRTS relevant register, B - relevant to both
2. A corresponding set of registers exists for adaprts1 from 0840h - 084Eh.

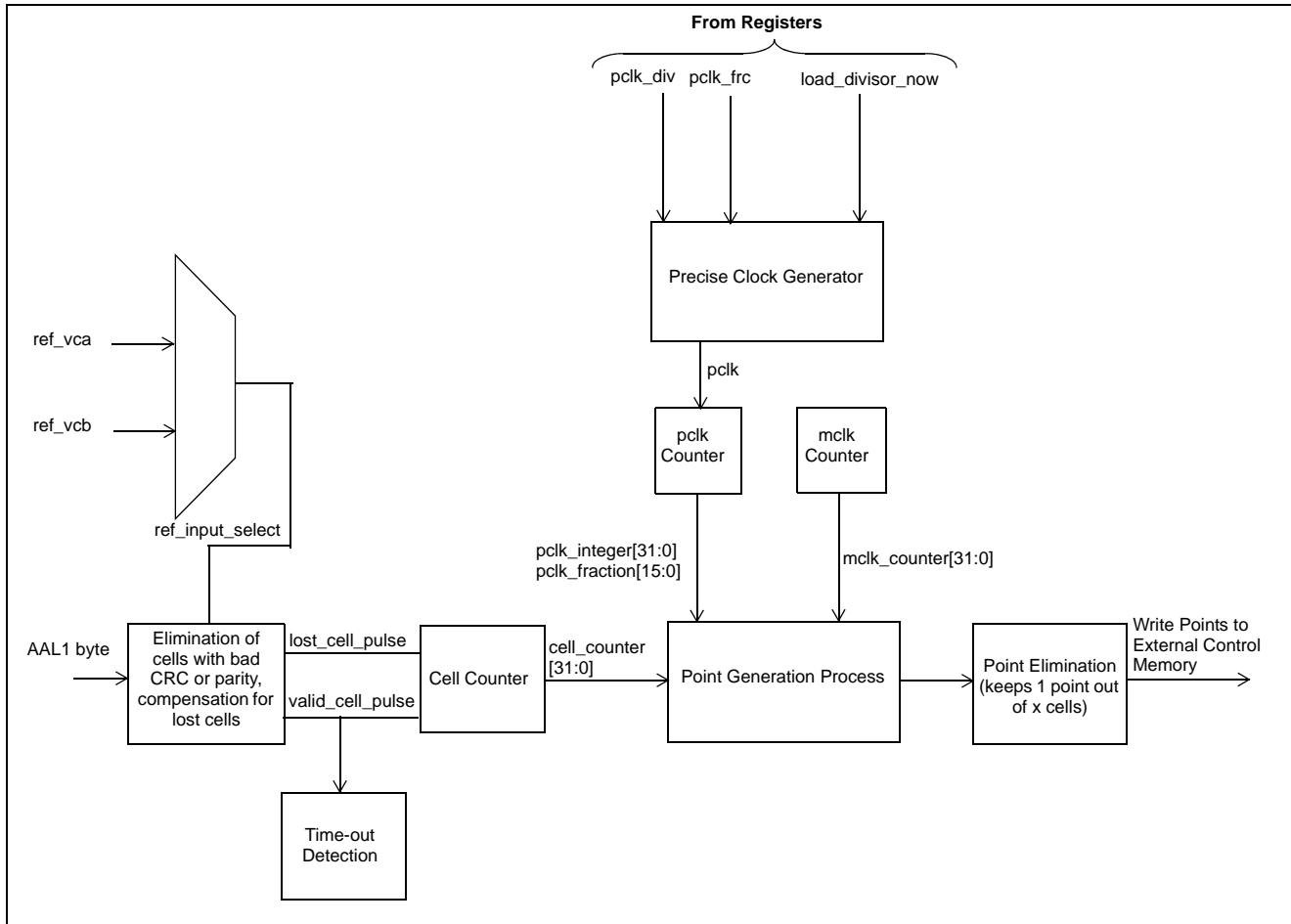

Figure 45 - Adaptive Clock Recovery

4.6.6 Adaptive Clock Recovery

Adaptive clock recovery is a method which generates a clock based on the rate at which AAL1 cells are arriving. The device acting as the master does not have to structure its cells differently or add any information, it simply transmits CBR data in AAL1 cells. The slave device performs the adaptive clock recovery, based on a clock recovery algorithm using points placed in external memory by the point generation module.

To perform adaptive clock recovery, the point generation module of the MT90503 is normally configured with the cell arrival event (ref_vca or ref_vcb) as its timing reference (source 0x20 or 0x21 of Table 28, “Source Selection,” on page 89). The VC’s which are defined as vca and vcb are recorded in the UTOPIA LUT (see Figure 39 on page 84). The input multiplexer gives the flexibility to use any clock desired. The cell arrival event is received directly from the UTOPIA look-up module. The look-up engine generates a VC-specific pulse and passes on the AAL1 byte of the received cell.

The AAL1 byte is composed of a sequence number (SN), CRC-3 sequence number protection (SNP) and a parity bit. The adaptive module checks for CRC and parity errors. If errors are found, the cell is ignored and the appropriate bit of register 0822h or 0842h is flagged. The sequence number is also verified to determine if cells have been lost. Single cell losses can be compensated for and the single_cell_lost register bit (0822h or 0842h [2]) will be set. Multiple cell losses cannot be compensated, but will be flagged as either multi_cell_lost (0822h or 0842h [3]) or cell_misinserted (0822h or 0842h [4]).

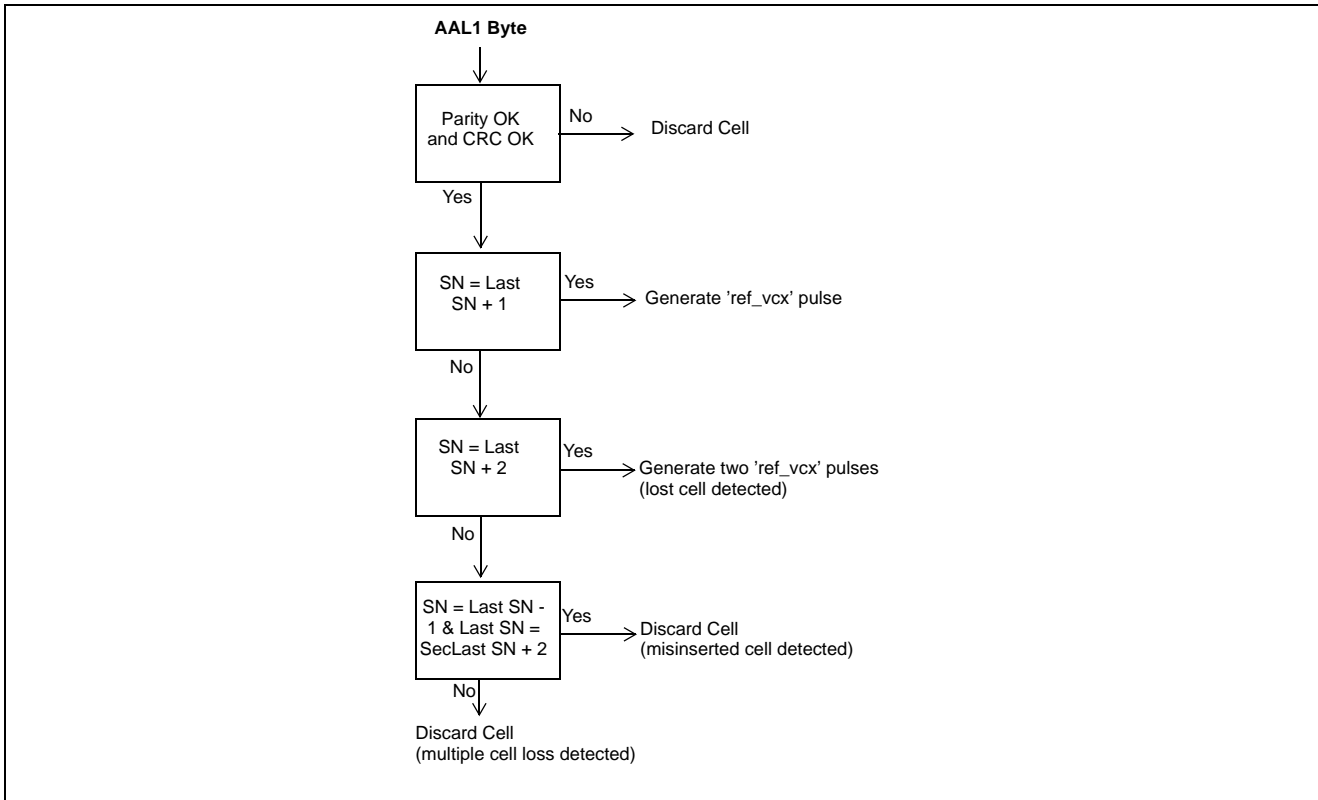

Figure 46 - Adaptive Cell Reception Flow

The point recording portion of the module records three fields. The 'number of the cell' is a 32-bit field, the 'number of mclk cycles' counted at time of cell arrival is a 32-bit field and the 'number of pclk cycles' counted when the cell received is a 48-bit field composed of a 32-bit integer and 16-bit fraction. This information, from the three counters (cell, mclk and pclk), 112 bits in total, is written to external control memory in a circular buffer reserved for clock recovery information. (See External Memory Point Format on page 98.) Ratios of this data are compared by the clock recovery algorithm to the desired ratios and correspondingly, corrections are made to the pclk frequency dividers.

It is possible to eliminate some of the timing reference cells sent to memory. This may be done in order to conserve processing power. It is especially useful if the clock recovery VC has a high number of channels (i.e. a high rate of cell arrival). The 8-bit registers, adap_pnt_elim_x (082Ah and 084Ah) can be programmed to "keep one point out of X".

Each adaptive module has its own associated pclk generator, allowing the wander of each VC to be tracked with respect to the pclk frequency.

4.6.6.1 SRTS Clock Recovery

The Synchronous Residual Time Stamp (SRTS) method of clock recovery is standardised in ITU-T I.363.1, ANSI T1.630 and Bellcore's patent¹ (U.S. Patent 5 260 978 (11/93)).

The SRTS method uses a stream of residual time stamps (RTS) to express the difference between a common reference clock (f_n) and a local service clock (f_s - derived from the local TDM clock, ct_c8_x).

1. Zarlink has entered into an agreement with Bellcore with respect to Bellcore's U.S. Patent No. 5,260,978 and Zarlink's manufacture and sale of products containing the SRTS function. However the purchase of this product does not grant the purchaser any rights under U.S. Patent No. 5,260,978. Use of this product or its resale as a component of another product may require a license under the patent which is available from Bell Communications Research, Inc., 445 South Street, Morristown, New Jersey 07960.

The point generation modules can both be configured for SRTS clock recovery and receive data simultaneously from 2 VCs. Like adaptive clock recovery, the data is retrieved from the UTOPIA look-up module. The SRTS values however, are spread over 8 cells. As in the adaptive mode, CRC errors, parity errors and missing cells are reported to their respective registers (0822h & 0842h [4:0]). This component of the SRTS recovery that receives SRTS data on a VC from an outside source generates "remote" data

The SRTS clock recovery method requires an accurate external reference clock (f_n) (e.g., a stratum 3 clock). This clock drives the 4-bit counter `fnxi_cnt`. This count is compared to a count driven by the precise clock digital PLL. In order to match the interval of 8 SRTS carrying cells, `pclk` (8 kHz) must be multiplied by K . K is proportional to the number of frames in the scheduler (P) (375 for fully filled structured AAL1) and inversely proportional to the number of channels open (Q) (respectively of registers 082Ch and 082Eh for point generation module 0 (adapsrts0)). i.e., $K=P/Q$. This component of the SRTS clock recovery that compares the `pclk` generated clock with that of the `fnxi` clock generates "local" data.

These "local" and "remote" values are written to external memory for the CPU to access.

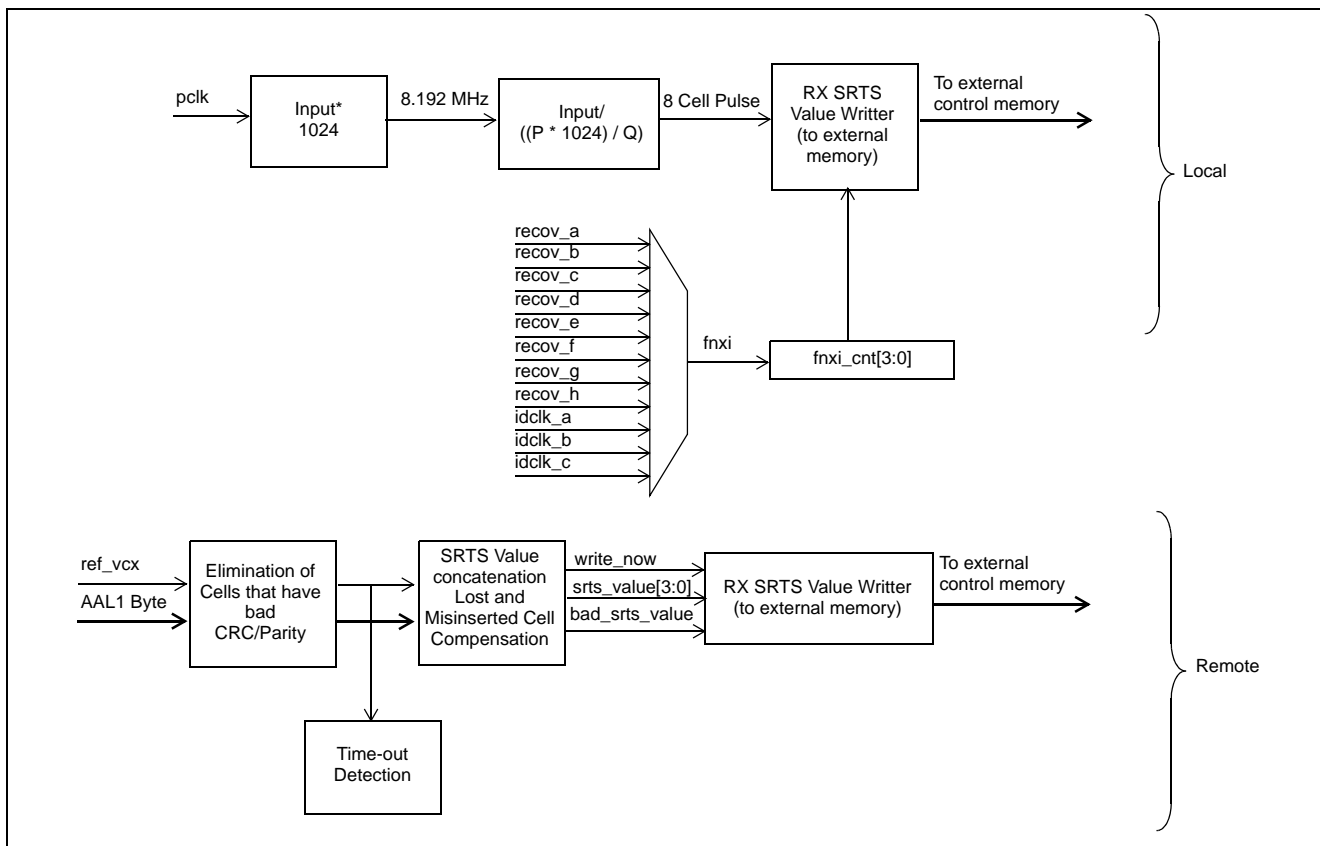

Figure 47 - Rx SRTS Clock Recovery Module

4.6.7 SRTS Transmission

Similar to the SRTS receive side, the generation of SRTS data must take into account the number of frames in the scheduler (P of register 0818h) and the number of channels in the VC (Q of register 081Ah). A single VC may be used to carry SRTS or the SRTS values may be broadcast on multiple VCs. These VCs must, however, be of the same format, consistent with the master SRTS VC. These VC's are configured in the Tx SAR (see Table 22 on page 65).

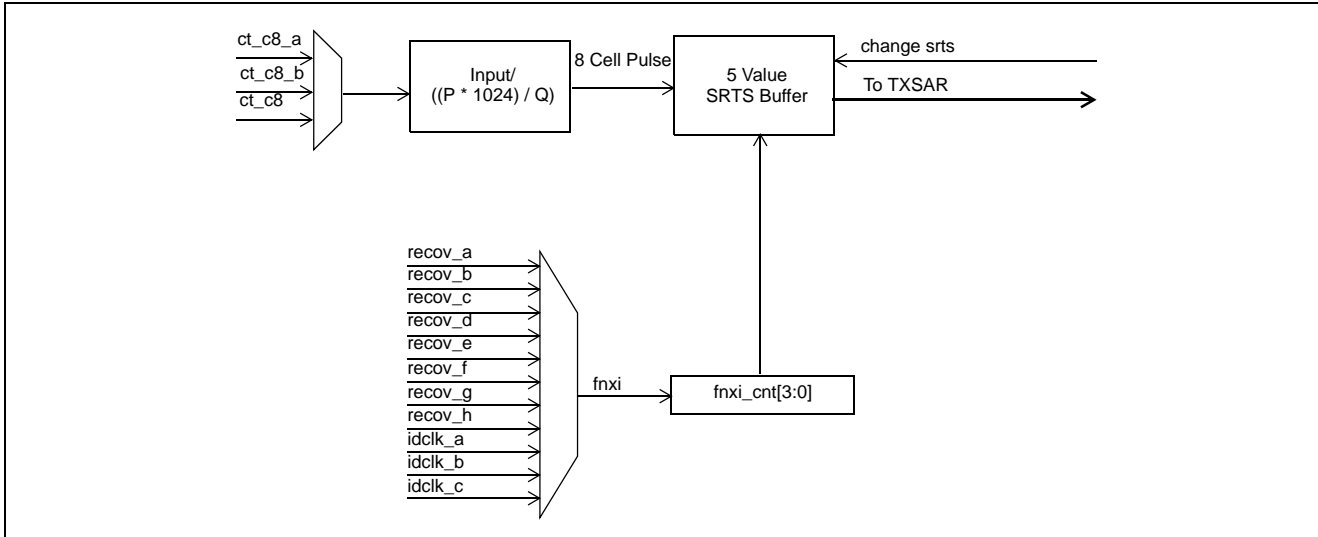

Figure 48 - Tx SRTS Clock Recovery Module

Register	Bits	Name	Description
0810h	0	enable	'1' enables Tx SRTS
0810h	[1:2]	bus_clk_sel	source of timing: '10' - ct_c8_a, '11' - ct_c8_b, '0x' - follows active clock, ct_c8_a or_b
0810h	[8:13]	fnxi_input_select	selects source of fnxi see Table 28
0812h	0	overflow	set if values sent by Tx SRTS is greater than the number of values read by the Tx SAR
0812h	1	underflow	set if the number of Tx SRTS values is less than that read by the Tx SAR
0814h	[0:1]		Interrupt Enables
0818h	[0:15]	srts8m8c_div_p	P = number of frames in the scheduler
081Ah	[0:15]	srts8m8c_div_q	Q = number of channels open

Table 32 - Tx SRTS Registers

4.6.8 External Memory Point Format

Figure 49 on page 99 indicates the format of the circular buffers in external memory that contain SRTS and adaptive point information. In adaptive clock recovery, a point is the information pertinent to the reception of a single cell. In SRTS, a point is the information corresponding to reception of an SRTS value (gathered over eight cells). If the received SRTS value is corrupt (due to errors in the received cells) the valid bit (V) will be 0.

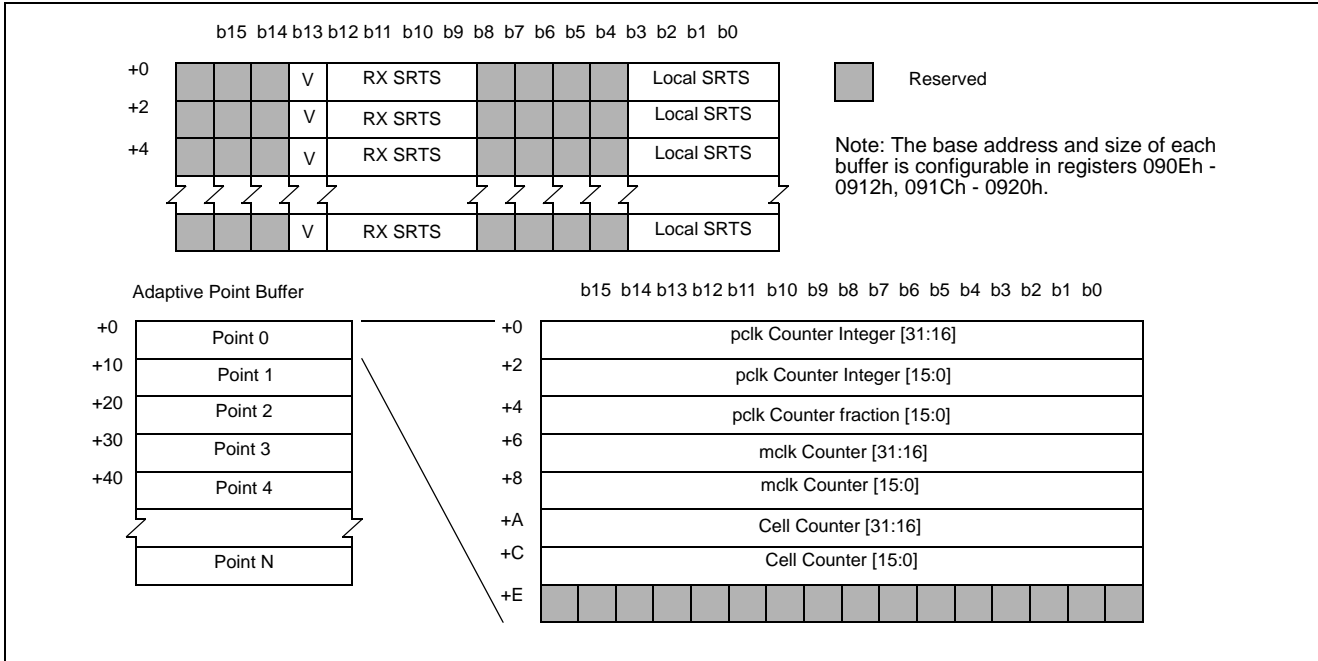

Figure 49 - Clock Recovery Information Buffers

Field	Name of Field	Bits Used	Description
V	Valid Bit	b12	Set if the accompanying RX SRTS value is valid
RX SRTS	Remote SRTS value	b11:b8	The 4-bit SRTS value from the incoming ATM cells on the designated VC.
Local SRTS	Local SRTS value	b3:b0	The 4-bit SRTS value calculated based on pclk and fnxi

Table 33 - SRTS Pointer Buffer, Field Description

5.0 Memory

5.1 Memory Overview

The MT90503 requires external memory for two purposes: control and data memory. The control memory contains information required for: TX_SARs and RX_SARs control structures, transmission schedulers, look up values to map VCs to RX structures. The control memory also stores data cell FIFO's. CAS buffers and clock recovery data is also stored in the control memory. The data memory is employed to store network traffic data for a maximum of 2048 bi-directional TDM channels.

The MT90503 interfaces with the external Data SSRAM via the following pins: 19 address pins (dmem_a), 4 memory bank/chip selection pins (dmem_cs), 16 data pins, (dmem_d), 2 parity pins (dmem_par), 1 R/W(low) pin used for late write memories (dmem_rw), 2 data memory byte write select pins (dmem_bws) and a memory clock (mem_clk). The external Control SSRAMs interface pins: 19 address pins (cmem_a), cmem_a[18] can be configured as a: memory bank/chip selection pin (cmem_cs[1]) or an address pin cmem_a[18], 1 dedicated memory bank/chip selection pin (cmem_cs[0]), 16 data pins, (cmem_d), 1 R/W(low) pin used for late write memories (cmem_rw), 2 control memory byte write select pins (cmem_bws).

The data memory supports up to 4 memory banks up to 512 k words per bank determining a data memory limit of 4 MB. The data memory clock speed gamut is 40 MHz to 80 MHz. Note: recommended mem_clk speed is 80 MHz. The option of a reduced memory capability is also supported. The following SSRAM sizes can be employed: 128 kB, 256 kB, 512 kB and 1 MB. The data bus consists of 18 data bits where two data bits are dedicated as parity bits. The parity bits are used to detect underruns in the circular buffers generated on the ATM link and data error detection. The parity check can be disabled to permit non-parity memory compatibility. The MT90503 supports 1, 2, 3 or 4 banks of external memory, each bank having a total capacity ranging from 64 k x 18 bits to 512 k x 18 bits. Therefore the MT90503 can operate with external memory ranging from 128 kB to 4 MB. The above data memory configuration is initialised via: Data Memory Parity 0 Register, Data Memory Parity 1 Register and Data Memory Configuration Register (0248h, 024Ah & 024Ch respectively).

The control memory maximum capacity is 512 k words and supports 2 memory banks. The reduced memory capability is supported in the same manner as the data memory. However, if all 19 address bits are employed then the use of 1 memory bank is permitted. Therefore the MT90503 can operate with external control memory ranging from 128 kB to 1 MB. The MT90503 does not use the parity bits supplied by the control memory. Parity bits can be generated within the MT90503 and are used for error detection. The above control memory configuration is initialised via: Control Memory Parity 0 Register, Control Memory Parity 1 Register and Control Memory Configuration Register (0240h, 0242h & 0244h respectively).

The MT90503 supports both Pipelined and Flow Through SSRAM employing either: 'normal' or 'Zero Bus Turnaround' (ZBT) operation. When PECL clock is employed 'Late-Write' is supported in 'normal' operation.

The memory clock (mem_clk) interface must be configured to either PECL or TTL. The interface can be initialised via the 'CPU Control Register' address 0100h.

The external memory controller can interface with several types of SSRAM, but they must support synchronous bus enabling. The SSRAM chip must only enable its data output buffers one cycle after a read (two for pipelined SSRAM), irrespective of the state of the asynchronous output enable pin. A read is indicated by mem_rw high and the appropriate mem_cs asserted. The SSRAM can be a registered input type (Synchronous, Synchronous Flow through or Synchronous Burst) or a registered input/output type (Synchronous pipelined). Although the MT90503 uses synchronous access feature of the memory, it does not use the burst access feature of the memory.

Specific Synchronous SRAM devices may require a turnaround cycle with respect to the bidirectional data bus. The MT90503 can be configured to insert a turnaround cycle between read access and write access. A turnaround cycle can be inserted between read access and read access to other memory banks. The turnaround cycle configuration is initialised via: Control Memory Configuration Register and Data Memory Configuration Register (0244h & 024Ch respectively). It should be noted that turnaround cycles restrict the memory bandwidth and therefore the operation MT90503. Maximum throughput is achieved with full clock speed on MCLK and without pipelined synchronous RAM and turnaround cycles.

5.2 Memory Map

The location of the absolute starting and ending addresses of the internal and external memories are shown in Table 34 - MT90503 Memory Map. The complete set of internal registers is listed in section 5.5 "Detailed Register Description", on Page 99.

Start Address	End Address	Name
0100h	01FEh	CPU Registers
0200h	02FEh	Main Registers
0300h	03FEh	UTOPIA Registers
0400h	04FEh	TDM Registers
0500h	05FEh	TX_SAR Registers
0600h	06FEh	Scheduler Registers
0700h	07FEh	RX_SAR Registers
0800h	08FEh	Clock Registers
0900h	09FEh	Miscellaneous Registers
0A00h	0AFEh	H.100 Registers
1000h	10FEh	TX SAR Input FIFO
1400h	14FEh	UTOPIA Port A Input FIFO
1800h	18FEh	UTOPIA Port B Input FIFO
1C00h	1CFEh	UTOPIA Port C Input FIFO
2000h	27FEh	RX SAR Output FIFO
3000h	33FEh	UTOPIA Port A Output FIFO
4000h	43FEh	UTOPIA Port B Output FIFO
5000h	53FEh	UTOPIA Port C Output FIFO
8000h	BFFEh	TDM Channel Association Memory
200000h	2FFFFEh	External Control Memory
400000h	7FFFFEh	External Data Memory

Table 34 - MT90503 Memory Map

5.3 Memory Controllers

Two memory controllers for external SSRAM exist in the MT90503: one for data memory and one for control memory. The memory controller blocks of the MT90503 reside between the internal blocks and the external memory. They receive memory access requests from the internal blocks (TDM, TX_SAR, RX_SAR, and CPU interface modules) and service them by reading data from, or writing data to, the external memories.

5.3.1 Data Memory

The data memory contains

- TX/RX circular buffers: one per channel, each with a programmable size of 128, 256, 512, or 1024 words.

The data memory can be up to 4 MB in size. This allows 2048 TDM channels to each have a maximum-size circular buffer: 2048 TDM channels * 2048 bytes/channel = 4 MB. A parity bit, necessary to detect underruns on incoming TDM data, can be disabled, allowing non-parity memory to be used. The parity bit, when enabled, is also used for error detection.

The data memory can be distributed between one and four banks. 16 to 19 address bits are required to access the 128 KB to 1 MB banks of data memory.

5.3.2 Control Memory

The control memory contains

- TX control structures: one per VC, minimum of 12 words each, maximum of 48 KB total
- RX control structures: one per VC, minimum of 14 words each, maximum of 56 KB total
- Transmit event schedulers: up to fifteen, typical sizes are 6 to 150 KB per enabled scheduler
- Look-up table: three LUTs, each with one entry per known VC, 4 or 8 bytes per entry
- Data cell FIFO: two FIFOs, each programmable in length from 4 to 16384 cells, 32 words per cell
- CAS change buffers: 1 to 32768 words in size
- Silent tone buffers: 1 to 32768 words in size
- Clock recovery point buffers: 9216 words in size
- Error message buffer: programmable length of 0 to 65536 error report structures, 4 words per structure.

The control memory can be up to 1 MB in size. A parity bit is used for error detection. The control memory can be distributed in either one or two banks. As with the data memory, 16 to 19 address bits are employed; when 19 address bits are used, only one memory bank can be supported.

5.3.3 Data Memory Controller

There are five agents which interact with the data memory controller: TX_SAR, RX_SAR, TDM transmit, TDM receive, and CPU (through the CPU interface). Of these five agents, all but the CPU send their accesses to their internal cache, one for each agent, from which the data is written into the data memory when the data memory bus is available. The internal caches are capable of buffering up to 128 words each.

Agent	Access types
TX_SAR	Reads
RX_SAR	Writes
TDM transmit	Writes
TDM receive	Reads
CPU	Reads and writes

Table 35 - Types of Data Memory accesses for each agent

The CPU has the highest priority on the write accesses and writes whenever it is flagged to do so. The priority arbitration used for accesses to the CPU is described in more detail the CPU module section (See 4.1 on page 34).

The memory controller generates the CRC-32 needed for each AAL5-VTOA cell.

5.3.4 Control Memory Controller

Unlike the data memory controller, the control memory controller does not contain internal caches. Agents' read/write requests are granted on a cycle-by-cycle basis and each agent waits until its request has been completed. Each agent has its own access port allowing it to communicate address, data, r/w, and write enable information with the memory controller. The agents are identified in Table 36 - on page 103.

Arbitration between the agents for control memory access is as follows: an agent can request a read or write at any time. The control memory will continue in its current mode (read or write) until no requests of that type are pending. Then, it will switch and service requests of the other mode. The CPU has the highest priority if the memory controller is handling accesses of the mode that the CPU requests. Other agents are granted access on a first-come first-served basis if the memory controller is handling accesses of the mode the agent requests.

Agent	Access types
TX_SAR	Reads and writes
RX_SAR	Reads and writes
UTOPIA (LUT)	Reads and writes
CPU	Reads and writes

Table 36 - Types of Control Memory Accesses For Each Agent

5.4 Register Overview

This section describes the MT90503's internal registers. An 8 KB memory block is reserved for the register mapping.

The register descriptions are grouped in the following sections:

- CPU Module Interface
- Main Registers
- UTOPIA Module
- TDM Module
- TX_SAR Module
- RX_SAR Module
- Clock Registers
- Miscellaneous Registers
- H.100/H.110 Bus Registers

5.5 Detailed Register Description

5.5.1 CPU Registers

Address: 100h Label: control Reset Value: 0000h			
Label	Bit Position	Type	Description
nreset_registers	0	RW	Controls the reset for the MAINREG module and certain CPU functions. '1' out of reset. '0' in reset. Should not be removed unless mclk is present.
nreset_chip_mclk_src	1	RW	Resets all other parts of the chip. '1' out of reset. '0' in reset. Should not be removed unless mclk is present.
nreset_txa_clk_mclk_src	2	RW	nreset for UTOPIA TXA clock (synchronized on mclk_src). This reset should not be removed unless the corresponding clock is present.
nreset_txb_clk_mclk_src	3	RW	nreset for UTOPIA TXB clock (synchronized on mclk_src). This reset should not be removed unless the corresponding clock is present.
nreset_txc_clk_mclk_src	4	RW	nreset for UTOPIA TXC clock (synchronized on mclk_src). This reset should not be removed unless the corresponding clock is present.
nreset_rxa_clk_mclk_src	5	RW	nreset for UTOPIA RXA clock (synchronized on mclk_src). This reset should not be removed unless the corresponding clock is present.
nreset_rxb_clk_mclk_src	6	RW	nreset for UTOPIA RXB clock (synchronized on mclk_src). This reset should not be removed unless the corresponding clock is present.
nreset_rxc_clk_mclk_src	7	RW	nreset for UTOPIA RXC clock (synchronized on mclk_src). This reset should not be removed unless the corresponding clock is present.
reserved	8	RW	For future use: reserved for mem_clk oe (TTL)
reserved	9	RW	For future use: reserved for PECL oe
mem_clk_o_enable	10	RW	Enables the mem_clk TTL output to toggle, active high
mem_clk_pecl_enable	11	RW	Enables the mem_clk PECL output to toggle, active high
mem_clk_input_sel	12	RW	'0' = mem_clk_i pin, '1' = mem_clk PECL pins
write_cache_enable	13	RW	When '0', only 1 access can be treated at a time. When '1', write cache contains 128 accesses. If this bit is '1', the average latency to perform a write will be reduced, but the worst-case latency will be increased.
reserved	14	RW	Reserved. Must be set to "0".
test_status	15	TS	When '1', all the status bits in the register will be set.

Table 37 - CPU Control Register

Address: 102h Label: status0 Reset Value: 0000h			
Label	Bit Position	Type	Description
reserved	0	RO	Reserved. Always read as "0".
reserved	1	RO	Reserved. Always read as "0".
reserved	2	RO	Reserved. Always read as "0".
internal_read_timeout	3	ROL	Goes high if a read access has been active for 32k mclk_src cycles without completion. Fatal chip error.
inmo_read_done	4	ROL	Indicates that an extended indirect access has completed. This is used to indicate to the host that read data is ready.
reserved	15:5	ROL	Reserved. Always read as "0000_0000_000"

Table 38 - CPU Status Register

Address: 104h Label: status0_ie Reset Value: 0000h			
Label	Bit Position	Type	Description
reserved	0	RO	Reserved. Always read as "0".
reserved	1	RO	Reserved. Always read as "0".
reserved	2	RO	Reserved. Always read as "0".
internal_read_timeout_ie	3	IE	When '1' and the corresponding status bit is '1', an interrupt will be generated.
inmo_read_done_ie	4	IE	When '1' and the corresponding status bit is '1', an interrupt will be generated.
reserved	15:5	RO	Reserved. Always read as "0000_0000_000".

Table 39 - CPU Interrupt Enable Register

Address: 10EH Label: counters Reset Value: 0000h			
Label	Bit Position	Type	Description
emul_mode	1:0	EMO	Indicates state of counters and status bits. "00" = normal mode, "01" = reset, "1x" = test mode. These bits are only present for tests and should never be used.
reserved	15:2	RW	Reserved. Must be "0000_0000_0000_00"

Table 40 - CPU Counter Register

Address: 120h			
Label: led1			
Reset Value: 3FD0h			
Label	Bit Position	Type	Description
mclk_src_freq[6:0]	6:0	RW	mclk_src Frequency in MHz
led_flash_freq[8:0]	15:7	RW	Determines the time in ms that the LEDs will be turned off to indicate link activity.

Table 41 - LED1 Register

Address: 122h			
Label: led2			
Reset Value: 0000h			
Label	Bit Position	Type	Description
led_test_mode	0	RW	If '0', the LED Flashing time will be determined in ms. If '1', the LED Flashing time will be determined in us.
reserved	15:1	RW	Reserved. Must be "0000_0000_0000_000"

Table 42 - LED2 Register

Address: 128h			
Label: pll_conf			
Reset Value: 00A1h			
Label	Bit Position	Type	Description
pll_div_x	2:0	RW	Divides mclk_src before entering the REF pin of the fast_clk PLL. Together, pll_div_x and pll_div_y determine the speed of fast_clk, which must be between 160 and 200 MHz.
pll_div_y	5:3	RW	Divides the feedback path from the output pin of the fast_clk PLL. Together, pll_div_x and pll_div_y determine the speed of fast_clk, which must be between 160 and 200 MHz.
pll_div_z	10:6	RW	Divides fast_clk to generate mem_clk
pll_bypass	11	RW	If '1', mclk_src divided by pll_div_x becomes fast_clk, bypassing the fast_clk PLL
nreset_pll_async	12	RW	Resets the module that divides mclk_src before being used as the REF pin of the fast_clk PLL
reserved	15:13	RO	Reserved. Always read as "000"

Table 43 - PLL Configuration Register

Address: 130h Label: inmo_a_gpi0 Reset Value: 0000h			
Label	Bit Position	Type	Description
inmo_a_in[14:0]	14:0	RO	Current level of the corresponding pin
reserved	15	RO	Reserved. Always read as "0"

Table 44 - Intel/Motorola Address Register

Address: 132h Label: inmo_a_gpi1 Reset Value: 0000h			
Label	Bit Position	Type	Description
inmo_a_rise0	0	ROL	This bit is set if the corresponding pin goes for '0' to '1'
inmo_a_rise1	1	ROL	This bit is set if the corresponding pin goes for '0' to '1'
inmo_a_rise2	2	ROL	This bit is set if the corresponding pin goes for '0' to '1'
inmo_a_rise3	3	ROL	This bit is set if the corresponding pin goes for '0' to '1'
inmo_a_rise4	4	ROL	This bit is set if the corresponding pin goes for '0' to '1'
inmo_a_rise5	5	ROL	This bit is set if the corresponding pin goes for '0' to '1'
inmo_a_rise6	6	ROL	This bit is set if the corresponding pin goes for '0' to '1'
inmo_a_rise7	7	ROL	This bit is set if the corresponding pin goes for '0' to '1'
inmo_a_rise8	8	ROL	This bit is set if the corresponding pin goes for '0' to '1'
inmo_a_rise9	9	ROL	This bit is set if the corresponding pin goes for '0' to '1'
inmo_a_rise10	10	ROL	This bit is set if the corresponding pin goes for '0' to '1'
inmo_a_rise11	11	ROL	This bit is set if the corresponding pin goes for '0' to '1'
inmo_a_rise12	12	ROL	This bit is set if the corresponding pin goes for '0' to '1'
inmo_a_rise13	13	ROL	This bit is set if the corresponding pin goes for '0' to '1'
inmo_a_rise14	14	ROL	This bit is set if the corresponding pin goes for '0' to '1'
reserved	15	RO	Reserved. Always read as "0:"

Table 45 - Intel/Motorola Address Rise Register

Address: 136h Label: inmo_a_gpi2 Reset Value: 0000h			
Label	Bit Position	Type	Description
inmo_a_fall0	0	ROL	This bit is set if the corresponding pin goes for '1' to '0'
inmo_a_fall1	1	ROL	This bit is set if the corresponding pin goes for '1' to '0'
inmo_a_fall2	2	ROL	This bit is set if the corresponding pin goes for '1' to '0'
inmo_a_fall3	3	ROL	This bit is set if the corresponding pin goes for '1' to '0'
inmo_a_fall4	4	ROL	This bit is set if the corresponding pin goes for '1' to '0'
inmo_a_fall5	5	ROL	This bit is set if the corresponding pin goes for '1' to '0'
inmo_a_fall6	6	ROL	This bit is set if the corresponding pin goes for '1' to '0'
inmo_a_fall7	7	ROL	This bit is set if the corresponding pin goes for '1' to '0'
inmo_a_fall8	8	ROL	This bit is set if the corresponding pin goes for '1' to '0'
inmo_a_fall9	9	ROL	This bit is set if the corresponding pin goes for '1' to '0'
inmo_a_fall10	10	ROL	This bit is set if the corresponding pin goes for '1' to '0'
inmo_a_fall11	11	ROL	This bit is set if the corresponding pin goes for '1' to '0'
inmo_a_fall12	12	ROL	This bit is set if the corresponding pin goes for '1' to '0'
inmo_a_fall13	13	ROL	This bit is set if the corresponding pin goes for '1' to '0'
inmo_a_fall14	14	ROL	This bit is set if the corresponding pin goes for '1' to '0'
reserved	15	RO	Reserved. Always read as "0"

Table 46 - Intel/Motorla Address Fall Register

Address: 140h Label: inmo_d_gpo Reset Value: 0000h			
Label	Bit Position	Type	Description
inmo_d_out8	0	RW	This is the value sent out on the corresponding pin, used in conjunction with the OE bit
inmo_d_out9	1	RW	This is the value sent out on the corresponding pin, used in conjunction with the OE bit
inmo_d_out10	2	RW	This is the value sent out on the corresponding pin, used in conjunction with the OE bit
inmo_d_out11	3	RW	This is the value sent out on the corresponding pin, used in conjunction with the OE bit

Table 47 - Intel/Motorola Data Out Register

Address: 140h Label: inmo_d_gpo Reset Value: 0000h			
Label	Bit Position	Type	Description
inmo_d_out12	4	RW	This is the value sent out on the corresponding pin, used in conjunction with the OE bit
inmo_d_out13	5	RW	This is the value sent out on the corresponding pin, used in conjunction with the OE bit
inmo_d_out14	6	RW	This is the value sent out on the corresponding pin, used in conjunction with the OE bit
inmo_d_out15	7	RW	This is the value sent out on the corresponding pin, used in conjunction with the OE bit
inmo_d_oe8	8	RW	This is OE bit used to drive the corresponding pin.
inmo_d_oe9	9	RW	This is OE bit used to drive the corresponding pin.
inmo_d_oe10	10	RW	This is OE bit used to drive the corresponding pin.
inmo_d_oe11	11	RW	This is OE bit used to drive the corresponding pin.
inmo_d_oe12	12	RW	This is OE bit used to drive the corresponding pin.
inmo_d_oe13	13	RW	This is OE bit used to drive the corresponding pin.
inmo_d_oe14	14	RW	This is OE bit used to drive the corresponding pin.
inmo_d_oe15	15	RW	This is OE bit used to drive the corresponding pin.

Table 47 - Intel/Motorola Data Out Register (continued)

Address 142h: Label: inmo_d_gpi0 Reset Value: 0000h			
Label	Bit Position	Type	Description
inmo_d_in8	0	RO	Current level of the corresponding pin
inmo_d_in9	1	RO	Current level of the corresponding pin
inmo_d_in10	2	RO	Current level of the corresponding pin
inmo_d_in11	3	RO	Current level of the corresponding pin
inmo_d_in12	4	RO	Current level of the corresponding pin
inmo_d_in13	5	RO	Current level of the corresponding pin
inmo_d_in14	6	RO	Current level of the corresponding pin
inmo_d_in15	7	RO	Current level of the corresponding pin
reserved	15:8	RO	Reserved. Always read as "0000_0000"

Table 48 - Intel/Motorola Data In Register

Address 144h: Label: inmo_d_gpi1 Reset Value: 0000h			
Label	Bit Position	Type	Description
inmo_d_rise8	0	ROL	This bit is set if the corresponding pin goes for '0' to '1'
inmo_d_rise9	1	ROL	This bit is set if the corresponding pin goes for '0' to '1'
inmo_d_rise10	2	ROL	This bit is set if the corresponding pin goes for '0' to '1'
inmo_d_rise11	3	ROL	This bit is set if the corresponding pin goes for '0' to '1'
inmo_d_rise12	4	ROL	This bit is set if the corresponding pin goes for '0' to '1'
inmo_d_rise13	5	ROL	This bit is set if the corresponding pin goes for '0' to '1'
inmo_d_rise14	6	ROL	This bit is set if the corresponding pin goes for '0' to '1'
inmo_d_rise15	7	ROL	This bit is set if the corresponding pin goes for '0' to '1'
inmo_d_fall8	8	ROL	This bit is set if the corresponding pin goes for '1' to '0'
inmo_d_fall9	9	ROL	This bit is set if the corresponding pin goes for '1' to '0'
inmo_d_fall10	10	ROL	This bit is set if the corresponding pin goes for '1' to '0'
inmo_d_fall11	11	ROL	This bit is set if the corresponding pin goes for '1' to '0'
inmo_d_fall12	12	ROL	This bit is set if the corresponding pin goes for '1' to '0'
inmo_d_fall13	13	ROL	This bit is set if the corresponding pin goes for '1' to '0'
inmo_d_fall14	14	ROL	This bit is set if the corresponding pin goes for '1' to '0'
inmo_d_fall15	15	ROL	This bit is set if the corresponding pin goes for '1' to '0'

Table 49 - Intel/Motorola Data Rise/Fall Register**5.5.2 Main Registers**

Address: 200h Label: control Reset Value: 0000h			
Label	Bit Position	Type	Description
reserved	14:0	RO	Reserved. Always read as "0000_0000_0000_000"
test_status	15	TS	When '1', all the status bits in the register will be set.

Table 50 - Main Control Register

Address: 202h Label: status0 Reset Value: 0000h			
Label	Bit Position	Type	Description
cmem_parity_error0	0	ROL	Indicates a parity error on data received from the control memory on the data bits [7:0]. This will only be detected if cmem_parity_conf[0] is '0'.
cmem_parity_error1	1	ROL	Indicates a parity error on data received from the control memory on the data bits [15:8]. This will only be detected if cmem_parity_conf[1] is '0'.
dmem_parity_error0	2	ROL	Indicates a parity error on data received from the data memory on the data bits [7:0]. This will only be detected if dmem_parity_conf[0] is '0'.
dmem_parity_error1	3	ROL	Indicates a parity error on data received from the data memory on the data bits [15:8]. This will only be detected if dmem_parity_conf[1] is '0'.
reserved	15:4	RW	Reserved. Must be "0000_0000_0000"

Table 51 - Main Status Register

Address: 204h Label: status0_ie Reset Value: 0000h			
Label	Bit Position	Type	Description
cmem_parity_error0_ie	0	IE	When '1' and the corresponding status bit is '1', an interrupt will be generated.
cmem_parity_error1_ie	1	IE	When '1' and the corresponding status bit is '1', an interrupt will be generated.
dmem_parity_error0_ie	2	IE	When '1' and the corresponding status bit is '1', an interrupt will be generated.
dmem_parity_error1_ie	3	IE	When '1' and the corresponding status bit is '1', an interrupt will be generated.
reserved	15:4	RW	Reserved. Must be "0000_0000_0000"

Table 52 - Main Interrupt Enable Register

Address: counters Label: 20Eh Reset Value: 0000h			
Label	Bit Position	Type	Description
emul_mode	1:0	EMO	Indicates state of counters and status bits. "00" = normal mode, "01" = reset, "1x" = test mode. These bits are only present for tests and should never be used.
reserved	15:2	RW	Reserved. Must be "0000_0000_0000_00"

Table 53 - Main Counter Register

Address: 220h Label: interrupt_flags Reset Value: 0000h			
Label	Bit Position	Type	Description
cpureg_interrupt_active	0	RO	When '1', indicates that the interrupt request for this module is active.
mainreg_interrupt_active	1	RO	When '1', indicates that the interrupt request for this module is active.
utoreg_interrupt_active	2	RO	When '1', indicates that the interrupt request for this module is active.
txreg_interrupt_active	3	RO	When '1', indicates that the interrupt request for this module is active.
rxreg_interrupt_active	4	RO	When '1', indicates that the interrupt request for this module is active.
miscreg_interrupt_active	5	RO	When '1', indicates that the interrupt request for this module is active.
wheelreg_interrupt_active	6	RO	When '1', indicates that the interrupt request for this module is active.
clkreg_interrupt_active	7	RO	When '1', indicates that the interrupt request for this module is active.
tdmreg_interrupt_active	8	RO	When '1', indicates that the interrupt request for this module is active.
mastreg_interrupt_active	9	RO	When '1', indicates that the interrupt request for this module is active.

Table 54 - Interrupt Flags Register

Address: 220h Label: interrupt_flags Reset Value: 0000h			
Label	Bit Position	Type	Description
casalarm_interrupt_active	10	RO	The CAS alarm occurs after the CAS alarm timeout period or if the CAS buffer becomes half full. This is used to ensure that the host can empty the CAS change buffer in a timely manner without having to poll its fill continuously.
tdmalarm_interrupt_active	11	RO	When '0', the clock divisor module is held in reset.
clkrecovalarm_interrupt_active	12	RO	The clock recovery alarm occurs after the clock recovery alarm timeout period or if either clock recovery buffer becomes half full. This is used to ensure that the host can empty the clock recovery point buffers in a timely manner without having to poll its fill continuously.
aal0alarm_interrupt_active	13	RO	The AAL0 alarm occurs after the AAL0 alarm timeout period or if the AAL0 buffer becomes half full. This is used to ensure that the host can empty the AAL0 cell buffer in a timely manner without having to poll its fill continuously.
erroralarm_interrupt_active	14	RO	The error alarm occurs after the error alarm timeout period or if the error report structure buffer becomes half full. This is used to ensure that the host can empty the error structure buffer in a timely manner without having to poll its fill continuously.
interrupt1_treated	15	PUL	Software must write this bit to '1', when it has finished servicing interrupts.

Table 54 - Interrupt Flags Register (continued)

Address: 224h Label: interrupt1_conf Reset Value: 0000h			
Label	Bit Position	Type	Description
min_interrupt1_period	13:0	RW	Number of us between interrupts (minimum). When 0000h, there is no minimum interval between interrupts. Programming this prevents the host from being flooded with interrupts. Each interrupt will last 1 us.
interrupt1_polarity	15:14	RW	Interrupt polarity and output enable. "00"=active low (open-collector); "01"=active high (open-collector); "10" = drive low; "11" = drive high. Drive low or drive high means that the pin's value will not change regardless of internal interrupts.

Table 55 - Interrupt1 Configuration Register

Address: 226h Label: interrupt2_conf Reset Value: 0000h			
Label	Bit Position	Type	Description
reserved	13:0	RW	Reserved. Must be "0000_0000_0000_00"
interrupt2_polarity	15:14	RW	Interrupt polarity and output enable. "00"=active low (open-collector); "01"=active high (open-collector); "10" = drive low; "11" = drive high. Drive low or drive high means that the pin's value will not change regardless of internal interrupts.

Table 56 - Interrupt2 Configuration Register

Address: 228h Label: interrupt1_enable Reset Value: 0000h			
Label	Bit Position	Type	Description
cpureg_interrupt1_enable	0	RW	When '1' and the corresponding interrupt active is '1', an interrupt will be generated on cpu_int[0].
mainreg_interrupt1_enable	1	RW	When '1' and the corresponding interrupt active is '1', an interrupt will be generated on cpu_int[0].
utoreg_interrupt1_enable	2	RW	When '1' and the corresponding interrupt active is '1', an interrupt will be generated on cpu_int[0].
txreg_interrupt1_enable	3	RW	When '1' and the corresponding interrupt active is '1', an interrupt will be generated on cpu_int[0].
rxreg_interrupt1_enable	4	RW	When '1' and the corresponding interrupt active is '1', an interrupt will be generated on cpu_int[0].
miscreg_interrupt1_enable	5	RW	When '1' and the corresponding interrupt active is '1', an interrupt will be generated on cpu_int[0].
wheelreg_interrupt1_enable	6	RW	When '1' and the corresponding interrupt active is '1', an interrupt will be generated on cpu_int[0].
clkreg_interrupt1_enable	7	RW	When '1' and the corresponding interrupt active is '1', an interrupt will be generated on cpu_int[0].
tdmreg_interrupt1_enable	8	RW	When '1' and the corresponding interrupt active is '1', an interrupt will be generated on cpu_int[0].
mastreg_interrupt1_enable	9	RW	When '1' and the corresponding interrupt active is '1', an interrupt will be generated on cpu_int[0].

Table 57 - Interrupt1 Enable Register

Address: 228h Label: interrupt1_enable Reset Value: 0000h			
Label	Bit Position	Type	Description
casalarm_interrupt1_enable	10	RW	When '1' and the corresponding interrupt active is '1', an interrupt will be generated on cpu_int[0].
tdmalarm_interrupt1_enable	11	RW	When '1' and the corresponding interrupt active is '1', an interrupt will be generated on cpu_int[0].
clkrecovalarm_interrupt1_enable	12	RW	When '1' and the corresponding interrupt active is '1', an interrupt will be generated on cpu_int[0].
aal0alarm_interrupt1_enable	13	RW	When '1' and the corresponding interrupt active is '1', an interrupt will be generated on cpu_int[0].
erroralarm_interrupt1_enable	14	RW	When '1' and the corresponding interrupt active is '1', an interrupt will be generated on cpu_int[0].
reserved	15	RW	Reserved. Must always be "0"

Table 57 - Interrupt1 Enable Register (continued)

Address: 22Ch Label: interrupt2_enable Reset Value: 0000h			
Label	Bit Position	Type	Description
cpureg_interrupt2_enable	0	RW	When '1' and the corresponding interrupt active is '1', an interrupt will be generated on cpu_int[1].
mainreg_interrupt2_enable	1	RW	When '1' and the corresponding interrupt active is '1', an interrupt will be generated on cpu_int[1].
utoreg_interrupt2_enable	2	RW	When '1' and the corresponding interrupt active is '1', an interrupt will be generated on cpu_int[1].
txreg_interrupt2_enable	3	RW	When '1' and the corresponding interrupt active is '1', an interrupt will be generated on cpu_int[1].
rxreg_interrupt2_enable	4	RW	When '1' and the corresponding interrupt active is '1', an interrupt will be generated on cpu_int[1].
misreg_interrupt2_enable	5	RW	When '1' and the corresponding interrupt active is '1', an interrupt will be generated on cpu_int[1].
wheelreg_interrupt2_enable	6	RW	When '1' and the corresponding interrupt active is '1', an interrupt will be generated on cpu_int[1].
clkreg_interrupt2_enable	7	RW	When '1' and the corresponding interrupt active is '1', an interrupt will be generated on cpu_int[1].

Table 58 - Interrupt2 Enable Register

Address: 22Ch Label: interrupt2_enable Reset Value: 0000h			
Label	Bit Position	Type	Description
tdmreg_interrupt2_enable	8	RW	When '1' and the corresponding interrupt active is '1', an interrupt will be generated on cpu_int[1].
mastreg_interrupt2_enable	9	RW	When '1' and the corresponding interrupt active is '1', an interrupt will be generated on cpu_int[1].
casalarm_interrupt2_enable	10	RW	When '1' and the corresponding interrupt active is '1', an interrupt will be generated on cpu_int[1].
tdmalarm_interrupt2_enable	11	RW	When '1' and the corresponding interrupt active is '1', an interrupt will be generated on cpu_int[1].
clkrecovalarm_interrupt2_enable	12	RW	When '1' and the corresponding interrupt active is '1', an interrupt will be generated on cpu_int[1].
aal0alarm_interrupt2_enable	13	RW	When '1' and the corresponding interrupt active is '1', an interrupt will be generated on cpu_int[1].
erroralarm_interrupt2_enable	14	RW	When '1' and the corresponding interrupt active is '1', an interrupt will be generated on cpu_int[1].
reserved	15	RW	Reserved. Must always be "0"

Table 58 - Interrupt2 Enable Register (continued)

Address: 230h Label: utopia_clock1 Reset Value: 0000h			
Label	Bit Position	Type	Description
utopia_porta_clk_oe	0	RW	0'=tri-state the txa_clk and rxa_clk; '1'=drive the txa_clk and rxa_clk. This should only be enabled if the chip is to drive these clocks, and only after the clock generation has been correctly programmed.
utopia_portb_clk_oe	1	RW	0'=tri-state the txb_clk and rxb_clk; '1'=drive the txb_clk and rxb_clk. This should only be enabled if the chip is to drive these clocks, and only after the clock generation has been correctly programmed.
utopia_portc_clk_oe	2	RW	This bit must be '0' as UTOPIA port C clocks must be input only.

Table 59 - Utopia Clock Register

Address: 230h Label: utopia_clock1 Reset Value: 0000h			
Label	Bit Position	Type	Description
utopia_txa_clk_select[1:0]	4:3	RW	"00" = select clock divisor A; "01" = select clock divisor B; "10" = select clock divisor C; "11" = reserved. There are 3 integer clock divisors used to generate the UTOPIA clocks, and each of the 6 UTOPIA clocks can be selected as any one of the 3.
utopia_txb_clk_select[1:0]	6:5	RW	"00" = select clock divisor A; "01" = select clock divisor B; "10" = select clock divisor C; "11" = reserved. There are 3 integer clock divisors used to generate the UTOPIA clocks, and each of the 6 UTOPIA clocks can be selected as any one of the 3.
utopia_txc_clk_select[1:0]	8:7	RW	Reserved.
utopia_rxa_clk_select[1:0]	10:9	RW	"00" = select clock divisor A; "01" = select clock divisor B; "10" = select clock divisor C; "11" = reserved.
utopia_rxb_clk_select[1:0]	12:11	RW	"00" = select clock divisor A; "01" = select clock divisor B; "10" = select clock divisor C; "11" = reserved.
utopia_rxc_clk_select[1:0]	14:13	RW	Reserved.
reserved	15	RW	Reserved. Must always be "0"

Table 59 - Utopia Clock Register (continued)

Address: 232h Label: utopia_gena Reset Value: 0001h			
Label	Bit Position	Type	Description
utopia_clk_diva[5:0]	5:0	RW	Integer divisor for input UTOPIA clock. Divides the selected clock source.
utopia_clk_divisor_load_nowa	6	PUL	Written to '1' when the source, divisor and inv. have been correctly programmed.
utopia_clk_inva	7	RW	Inverts the output of the clock divisor
utopia_clk_srca[2:0]	10:8	RW	"000"=txa_clk_in; "001"=txb_clk_in; "010"=txc_clk_in; "011"=rxa_clk_in; "100"=rxb_clk_in;"101"=rxc_clk_in; "110"=mclk; "111"=fast_clk.
utopia_clk_divisor_reseta	11	RW	When '0', the clock divisor module is held in reset.

Table 60 - Utopia Clock Generation A Register

Address: 232h Label: utopia_gena Reset Value: 0001h			
Label	Bit Position	Type	Description
reserved	15:12	RW	Reserved. Must always be "0000"

Table 60 - Utopia Clock Generation A Register

Address: 234h Label: utopia_genb Reset Value: 0001h			
Label	Bit Position	Type	Description
utopia_clk_divb[5:0]	5:0	RW	Integer divisor for input UTOPIA clock. Divides the selected clock source.
utopia_clk_divisor_load_nowb	6	PUL	Written to '1' when the source, divisor and inv. have been correctly programmed.
utopia_clk_invb	7	RW	Inverts the output of the clock divisor
utopia_clk_srcb[2:0]	10:8	RW	"000"=txa_clk_in; "001"=txb_clk_in; "010"=txc_clk_in; "011"=rxa_clk_in; "100"=rxb_clk_in; "101"=rxc_clk_in; "110"=mclk; "111"=fast_clk.
utopia_clk_divisor_reseta	11	RW	When '0', the clock divisor module is held in reset.
reserved	15:12	RW	Reserved. Must always be "0000"

Table 61 - Utopia Clock Generation B Register

Address: 236h Label: utopia_genc Reset Value: 0001h			
Label	Bit Position	Type	Description
utopia_clk_divc[5:0]	5:0	RW	Integer divisor for input UTOPIA clock. Divides the selected clock source.
utopia_clk_divisor_load_nowc	6	PUL	Written to '1' when the source, divisor and inv. have been correctly programmed.
utopia_clk_invc	7	RW	Inverts the output of the clock divisor
utopia_clk_srcc[2:0]	10:8	RW	"000"=txa_clk_in; "001"=txb_clk_in; "010"=txc_clk_in; "011"=rxa_clk_in; "100"=rxb_clk_in; "101"=rxc_clk_in; "110"=mclk; "111"=fast_clk.

Table 62 - Utopia Clock Generation C Register

Address: 236h Label: utopia_genc Reset Value: 0001h			
Label	Bit Position	Type	Description
utopia_clk_divisor_resetc	11	RW	When '0', the clock divisor module is held in reset.
reserved	15:12	RW	Reserved. Must always be "0000"

Table 62 - Utopia Clock Generation C Register

Address: 240h Label: cmem_parity0 Reset Value: 0000h			
Label	Bit Position	Type	Description
cmem_parity_conf[1:0]	1:0	RW	0' = parity bits; '1' = user data. In normal chip operation, this field should be set to "00", because the chip does not use the parity bits of the control memory.
cmem_parity_generation_add_mask [18:16]	4:2	RW	Mask of address bits [18:16] to be used to generate parity for the control memory. A '1' in one of these bits indicates that the corresponding address bit will be used to generate parity.
reserved	7:5	RO	Reserved. Must always be "0000"
cmem_parity_generation_data_mask	15:8	RW	Mask of data bits to be used to generate parity for the control memory. A '1' in one of these bits indicates that the data bit will be used to generate parity.

Table 63 - Control Memory Parity0 Register

Address: 242h Label: cmem_parity1 Reset Value: 0000h			
Label	Bit Position	Type	Description
cmem_parity_generation_add_mask [15:0]	15:0	RW	Mask of address bits [15:0] to be used to generate parity for the control memory. A '1' in one of these bits indicates that the corresponding address bit will be used to generate parity.

Table 64 - Control Memory Parity1 Register

Address: 244h Label: cmem_conf Reset Value: 0010h			
Label	Bit Position	Type	Description
cmem_add_lines	1:0	RW	"11" = 1 MB per chip; "10" = 512 KB per chip; "01" = 256KB per chip; "00" = 128 KB per chip
cmem_mem_type	3:2	RW	"00" = flowthrough ZBT; "01" = flowthrough SSRAM; "10" = pipelined ZBT; "11" = pipelined SSRAM.
cmem_rw_ta	4	RW	0 = no read/write turn-around cycles; 1 = 1 read/write turn-around cycle.
reserved	15:5	RO	Reserved. Always read as "0000_0000_000"

Table 65 - Control Memory Configuration Register

Address: 248h Label: dmem_parity0 Reset Value: 0000h			
Label	Bit Position	Type	Description
dmem_parity_conf[1:0]	1:0	RW	0' = parity bits; '1' = user data.
dmem_parity_generation_add_mask [20:16]	6:2	RW	Mask of address bits [20:16] to be used to generate parity for the data memory. A '1' in one of these bits indicates that the corresponding address bit will be used to generate parity.
reserved	7	RO	Reserved. Always read as "0"
dmem_parity_generation_data_mask	15:8	RW	Mask of data bits to be used to generate parity for the data memory. A '1' in one of these bits indicates that the corresponding data bit will be used to generate parity.

Table 66 - Data Memory Parity 0 Register

Address: 24Ah Label: dmem_parity1 Reset Value: 0000h			
Label	Bit Position	Type	Description
dmem_parity_generation_add_mask [15:0]	15:0	RW	Mask of address bits [15:0] to be used to generate parity for the data memory. A '1' in one of these bits indicates that the corresponding address bit will be used to generate parity.

Table 67 - Data Memory Parity 1 Register

Address: 24Ch Label: dmem_conf Reset Value: 0010h			
Label	Bit Position	Type	Description
dmem_add_lines	1:0	RW	"11" = 1 MB per chip; "10" = 512 KB per chip; "01" = 256KB per chip; "00" = 128 KB per chip
dmem_mem_type	3:2	RW	"00" = flowthrough ZBT; "01" = flowthrough SSRAM; "10" = pipelined ZBT; "11" = pipelined SSRAM.
dmem_rw_ta	4	RW	0 = no read/write turn-around cycles; 1 = 1 read/write turn-around cycle.
reserved	15:5	RO	Reserved. Always read as "0000_0000_000"

Table 68 - Data Memory Configuration Register

5.5.3 UTOPIA Registers

Address: 300h Label: control Reset Value: 0900h			
Label	Bit Position	Type	Description
rx_a_ena	0	RW	Enables UTOPIA port RXA
rx_a_sar	1	RW	0' = chip acts as PHY, '1' = chip acts as SAR
rx_a_width	2	RW	0' = 8-bit UTOPIA bus, '1' = 16-bit UTOPIA bus
rx_b_ena	3	RW	Enables UTOPIA port RXB
rx_b_sar	4	RW	0' = chip acts as PHY, '1' = chip acts as SAR
rx_b_width	5	RW	0' = 8-bit UTOPIA bus, '1' = 16-bit UTOPIA bus

Table 69 - Utopia Control Register

Address: 300h Label: control Reset Value: 0900h			
Label	Bit Position	Type	Description
txa_sar	6	RW	0' = chip acts as PHY, '1' = chip acts as SAR
txa_width	7	RW	0' = 8-bit UTOPIA bus, '1' = 16-bit UTOPIA bus
txa_multiply	8	RW	0' = always drive DAT/PAR/SOC pins; '1' = only drive when selected. Only applicable when chip is in PHY mode.
txb_sar	9	RW	0' = chip acts as PHY, '1' = chip acts as SAR
txb_width	10	RW	0' = 8-bit UTOPIA bus, '1' = 16-bit UTOPIA bus
txb_multiply	11	RW	0' = always drive DAT/PAR/SOC pins; '1' = only drive when selected. Only applicable when chip is in PHY mode.
add_pin_ena	12	RW	If '1', UTOPIA port A is level-2 with addressing. When this bit is set, rxb_width and txb_width must be '0'.
reserved	13	RW	Reserved. Must always be "0"
null_cell_elim	14	RW	When '1', all cells with VPI and VCI equal to '0' will be discarded. Otherwise, they will be kept and treated normally.
test_status	15	TS	When '1', all the status bits in the register will be set.

Table 69 - Utopia Control Register (continued)

Address: 302h Label: control1 Reset Value: 0008h			
Label	Bit Position	Type	Description
rx_c_ena	0	RW	Enables UTOPIA port RXC
rx_c_sar	1	RW	0' = chip acts as PHY, '1' = chip acts as SAR
tx_c_sar	2	RW	0' = chip acts as PHY, '1' = chip acts as SAR
tx_c_multiply	3	RW	0' = always drive DAT/PAR/SOC pins; '1' = only drive when selected. Only applicable when chip is in PHY mode.
uto_output_enable	4	RW	0' Tri-states the ENA or CLAV pin driven by the chip. '1' drives. This bit should be set to '1' after all PHY/SAR register bits have been programmed, but before all rx_ena bits are set.
phy_alarm_pol	6:5	RW	"00" = PHY alarm disabled, "01" = PHY alarm active-high, "10" = PHY alarm active-low, "11" = reserved.

Table 70 - Utopia Control1 Register

Address: 302h Label: control1 Reset Value: 0008h			
Label	Bit Position	Type	Description
long_lut_entries	7	RW	When '0', LUT entries are 4 bytes long. When '1', LUT entries are 8 bytes long. Long LUT entries should only be used if header translation is to be performed.
rx_a_nni_null_elim	8	RW	1' consider NNI VPI bits for null cell elimination for port RXA. If '0', the high 4 bits of the header (GFC field) will be ignored for null cell elimination.
rx_b_nni_null_elim	9	RW	1' consider NNI VPI bits for null cell elimination for port RXB. If '0', the high 4 bits of the header (GFC field) will be ignored for null cell elimination.
rx_c_nni_null_elim	10	RW	1' consider NNI VPI bits for null cell elimination for port RXC. If '0', the high 4 bits of the header (GFC field) will be ignored for null cell elimination.
phy_a_tx_led_conf	11	RW	When '0', phy_a_tx_led pin functions as a LED. When '1', functions as GPIO.
phy_a_rx_led_conf	12	RW	When '0', phy_a_rx_led pin functions as a LED. When '1', functions as GPIO.
phy_b_tx_led_conf	13	RW	When '0', phy_b_tx_led pin functions as a LED. When '1', functions as GPIO.
phy_b_rx_led_conf	14	RW	When '0', phy_b_rx_led pin functions as a LED. When '1', functions as GPIO.
reserved	15	RW	Reserved. Must always be "0"

Table 70 - Utopia Control1 Register (continued)

Address: 304h Label: status0 Reset Value: 0000h			
Label	Bit Position	Type	Description
rx_cell_loss	0	ROL	Indicates an overflow in the buffer from UTOPIA to the RX SAR
out_a_cell_loss	1	ROL	Indicates an overflow in the output buffer for port TXA
out_b_cell_loss	2	ROL	Indicates an overflow in the output buffer for port TXB
out_c_cell_loss	3	ROL	Indicates an overflow in the output buffer for port TXC
cell_loss_rollover	4	CRL	Indicates that the cell_loss_counter register has wrapped

Table 71 - Utopia Status 0 Register

Address: 304h Label: status0 Reset Value: 0000h			
Label	Bit Position	Type	Description
tx_arr_rollover	5	CRL	Indicates that the tx_sar_cell_arrival register has wrapped
rx_dep_rollover	6	CRL	Indicates that the rx_sar_cell_departure register has wrapped
ia_arr_rollover	7	CRL	Indicates that the porta_cell_arrival register has wrapped
oa_dep_rollover	8	CRL	Indicates that the porta_cell_departure register has wrapped
ib_arr_rollover	9	CRL	Indicates that the portb_cell_arrival register has wrapped
ob_dep_rollover	10	CRL	Indicates that the portb_cell_departure register has wrapped
ic_arr_rollover	11	CRL	Indicates that the portc_cell_arrival register has wrapped
oc_dep_rollover	12	CRL	Indicates that the portc_cell_departure register has wrapped
rx_a_parity_error	13	ROL	Indicates a parity error on port RXA
rx_b_parity_error	14	ROL	Indicates a parity error on port RXB
rx_c_parity_error	15	ROL	Indicates a parity error on port RXC

Table 71 - Utopia Status 0 Register (continued)

Address: 30Ch Label: status2 Reset Value: 0000h			
Label	Bit Position	Type	Description
phy_alarma	0	ROLO	This bit is set when phy_a_alm pin is active. Active polarity is determined by phy_alarm_pol register
phy_alarmb	1	ROLO	This bit is set when phy_b_alm pin is active. Active polarity is determined by phy_alarm_pol register
test_a_bit	2	ROL	Bit is set when look-up engine gives a pulse on clock recovery VC A. Used for tests.
test_b_bit	3	ROL	Bit is set when look-up engine gives a pulse on clock recovery VC B. Used for tests.
reserved	15:4	RW	Reserved. Must always be "0000_0000_0000"

Table 72 - Utopia Status 2 Register

Address: 30Eh Label: status2_ie Reset Value: 0000h			
---	--	--	--

Table 73 - Utopia Interrupt Enable 2 Register

Label	Bit Position	Type	Description
phy_alarma_ie	0	IE	When '1' and the corresponding status bit is '1', an interrupt will be generated.
phy_alarmb_ie	1	IE	When '1' and the corresponding status bit is '1', an interrupt will be generated.
test_a_bit_ie	2	IE	When '1' and the corresponding status bit is '1', an interrupt will be generated.
test_b_bit_ie	3	IE	When '1' and the corresponding status bit is '1', an interrupt will be generated.
reserved	15:4	IE	When '1' and the corresponding status bit is '1', an interrupt will be generated.

Table 73 - Utopia Interrupt Enable 2 Register

Address: 310h Label: counters Reset Value: 0000h			
Label	Bit Position	Type	Description
emul_mode	1:0	EMO	Indicates state of counters and status bits. "00" = normal mode, "01" = reset, "1x" = test mode. These bits are only present for tests and should never be used.
cell_loss_emul	2	EMU	When emul_mode = "11", writing '1' to this bit will increment the cell_loss counter by 1
tx_arr_emul	3	EMU	When emul_mode = "11", writing '1' to this bit will increment the tx_arr counter by 1
rx_dep_emul	4	EMU	When emul_mode = "11", writing '1' to this bit will increment the rx_dep counter by 1
ia_arr_emul	5	EMU	When emul_mode = "11", writing '1' to this bit will increment the ia_arr counter by 1
oa_dep_emul	6	EMU	When emul_mode = "11", writing '1' to this bit will increment the oa_dep counter by 1
ib_arr_emul	7	EMU	When emul_mode = "11", writing '1' to this bit will increment the ib_arr counter by 1
ob_dep_emul	8	EMU	When emul_mode = "11", writing '1' to this bit will increment the ob_dep counter by 1
ic_arr_emul	9	EMU	When emul_mode = "11", writing '1' to this bit will increment the ic_arr counter by 1
oc_dep_emul	10	EMU	When emul_mode = "11", writing '1' to this bit will increment the oc_dep counter by 1
reserved	15:11	RW	Reserved. Must always be "0000_0"

Table 74 - Utopia Counters Register

Address: 312h Label: cell_loss_counters Reset Value: 0000h			
Label	Bit Position	Type	Description
cell_loss	15:0	CNT	Counts the number of cells lost due to fifo overflows. This includes the output fifos from the look-up engine to the: RX SAR, ports TXA, TXB, TXC.

Table 75 - Cell Loss Counters Register

Address: 320h Label: porta_look_up_base Reset Value: 0000h			
Label	Bit Position	Type	Description
luta_base	15:0	RW	Bits 19:4 of the address of the look-up table for port A.

Table 76 - Port A Look Up Table Address Register

Address: 322h Label: porta_num_vpi_vci_bits Reset Value: 0000h			
Label	Bit Position	Type	Description
num_vpi_vci_bits	15:0	RW	Indicates the total number of bits that are used to decode the look-up address for port A. 0001h = 1 bit used, FFFFh = 16 bits used. When subtracted from vci_n, this indicates the number of VPI bits used.

Table 77 - Port A VPI/VCI Identification Register

Address: 324h Label: porta_concatenation Reset Value: 0000h			
Label	Bit Position	Type	Description
vci_na	4:0	RW	Indicates the number of VCI bits used to decode the look-up address for port A.

Table 78 - Port A Concatenation Register

Address: 324h Label: porta_concatenation Reset Value: 0000h			
Label	Bit Position	Type	Description
reserved	15:5	RW	Reserved. Must always be "0000_0000_000"

Table 78 - Port A Concatenation Register

Address: 328h Label: porta_vpi_match Reset Value: 0000h			
Label	Bit Position	Type	Description
vpi_matcha	11:0	RW	For a cell from port A to be considered valid, any bits in its VPI whose corresponding bits in reg 32Ah are '1' must have the value contained in this register.
reserved	15:12	RW	Reserved. Must always be "0000"

Table 79 - Port A VPI Match Register

Address: 32Ah Label: porta_vci_mask Reset Value: 0000h			
Label	Bit Position	Type	Description
vpi_maska	11:0	RW	For a cell from port A to be considered valid, any bits in its VPI whose corresponding bits in this register are '1' must have the value contained in reg 328h.
reserved	15:12	RW	Reserved. Must always be "0000"

Table 80 - Port A VCI Mask Register

Address: 32Ch Label: porta_vci_match Reset Value: 0000h			
Label	Bit Position	Type	Description
vci_matcha	15:0	RW	For a cell from port A to be considered valid, any bits in its VCI whose corresponding bits in reg 32Eh are '1' must have the value contained in this register.

Table 81 - Port A VCI Match Register

Address: 32Eh Label: porta_vci_mask Reset Value: 0000h			
Label	Bit Position	Type	Description
vci_maska	15:0	RW	For a cell from port A to be considered valid, any bits in its VCI whose corresponding bits in this register are '1' must have the value contained in reg 32Ch.

Table 82 - Port A VCI Mask Register

Address: 330h Label: porta_cell_arrival_high Reset Value: 0000h			
Label	Bit Position	Type	Description
ia_arr[31:16]	15:0	CNT	Freerunning counter of the number of cells received on port A.

Table 83 - Port A Cell Arrival Counter High Register

Address: 332h Label: porta_cell_arrival_low Reset Value: 0000h			
Label	Bit Position	Type	Description
ia_arr[15:0]	15:0	CNT	Freerunning counter of the number of cells received on port A.

Table 84 - Port A Cell Arrival Counter Low Register

Address: 334h Label: porta_cell_departure_high Reset Value: 0000h			
Label	Bit Position	Type	Description
oa_dep[31:16]	15:0	CNT	Freerunning counter of the number of cells transmitted on port A.

Table 85 - Port A Cell Departure Counter High Register

Address: 336h Label: porta_cell_departure_low Reset Value: 0000h			
Label	Bit Position	Type	Description
oa_dep[15:0]	15:0	CNT	Freerunning counter of the number of cells transmitted on port A.

Table 86 - Port A Cell Departure Low Register

Address: 338h Label: porta_overflow0 Reset Value: 0000h			
Label	Bit Position	Type	Description
ia_rx_cell_max	4:0	RW	If the cell fill of the RX SAR output FIFO becomes greater than this value, cells from the port A input FIFO will be blocked. 0h = no backpressure
ia_oa_cell_max	9:5	RW	If the cell fill of the Port A output FIFO becomes greater than this value, cells from the port A input FIFO will be blocked. 0h = no backpressure
ia_ob_cell_max	14:10	RW	If the cell fill of the Port B output FIFO becomes greater than this value, cells from the port A input FIFO will be blocked. 0h = no backpressure
reserved	15	RW	Reserved. Must always be "0"

Table 87 - Port A Overflow0 Register

Address: 33Ah Label: porta_overflow1 Reset Value: 0000h			
Label	Bit Position	Type	Description
ia_oc_cell_max	4:0	RW	If the cell fill of the Port C output FIFO becomes greater than this value, cells from the port A input FIFO will be blocked. 0h = no backpressure
reserved	15:5	RW	Reserved. Must always be "0000_0000_000"

Table 88 - Port A Overflow1 Register

Address: 33Ch Label: porta_address Reset Value: 0000h			
Label	Bit Position	Type	Description
porta_add	4:0	RW	UTOPIA address to which the chip will repond when programmed as a level-2 PHY.
reserved	15:5	RW	Reserved. Must always be "0000_0000_000"

Table 89 - Port A Address Register

Address: 340h Label: portb_look_up_b Reset Value: 0000h			
Label	Bit Position	Type	Description
lutb_base	15:0	RW	Bits 19:4 of the address of the look-up table for port B.

Table 90 - Port B Look Up Table Register

Address: 342h Label: portb_num_vpi_vci_bits Reset Value: 0000h			
Label	Bit Position	Type	Description
num_vpi_vci_bits	15:0	RW	Indicates the total number of bits that are used to decode the look-up address for port B. 0001h = 1 bit used, FFFFh = 16 bits used. When subtracted from vci_n, this indicates the number of VPI bits used.

Table 91 - Port B VPI/VCI Identification Register

Address: 344h Label: portb_concatenation Reset Value: 0000h			
Label	Bit Position	Type	Description
vci_nb	4:0	RW	Indicates the number of VCI bits used to decode the look-up address for port B.
reserved	15:5	RW	Reserved. Must always be "0000_0000_000"

Table 92 - Port B Concatenation Register

Address: 348h Label: portb_vpi_match Reset Value: 0000h			
Label	Bit Position	Type	Description
vpi_matchb	11:0	RW	For a cell from port B to be considered valid, any bits in its VPI whose corresponding bits in reg 34Ah are '1' must have the value contained in this register.
reserved	15:12	RW	Reserved. Must always be "0000"

Table 93 - Port B VPI Match Register

Address: 34Ah Label: portb_vpi_mask Reset Value: 0000h			
Label	Bit Position	Type	Description
vpi_maskb	11:0	RW	For a cell from port B to be considered valid, any bits in its VPI whose corresponding bits in this register are '1' must have the value contained in reg 348h.
reserved	15:12	RW	Reserved. Must always be "0000"

Table 94 - Port B VPI Mask Register

Address: 34Ch Label: portb_vci_match Reset Value: 0000h			
Label	Bit Position	Type	Description
vci_matchb	15:0	RW	For a cell from port B to be considered valid, any bits in its VCI whose corresponding bits in reg 34Eh are '1' must have the value contained in this register.

Table 95 - Port B VCI Match Register

Address: 34Eh Label: portb_vci_mask Reset Value: 0000h			
Label	Bit Position	Type	Description
vci_maskb	15:0	RW	For a cell from port B to be considered valid, any bits in its VCI whose corresponding bits in this register are '1' must have the value contained in reg 34Ch.

Table 96 - Port B VCI Mask Register

Address: 350h Label: portb_cell_arrival_high Reset Value: 0000h			
Label	Bit Position	Type	Description
ib_arr[31:16]	15:0	CNT	Freerunning counter of the number of cells received on port B.

Table 97 - Port B Cell Arrival Counter High Register

Address: 352h Label: portb_cell_arrival_low Reset Value: 0000h			
Label	Bit Position	Type	Description
ib_arr[15:0]	15:0	CNT	Freerunning counter of the number of cells received on port B.

Table 98 - Port B Cell Arrival Counter Low Register

Address: 354h Label: portb_cell_departure_high Reset Value: 0000h			
Label	Bit Position	Type	Description
ob_dep[31:16]	15:0	CNT	Freerunning counter of the number of cells transmitted on port B.

Table 99 - Port B Cell Departure Counter High Register

Address: 356h Label: portb_cell_departure_low Reset Value: 0000h			
Label	Bit Position	Type	Description
ob_dep[15:0]	15:0	CNT	Freerunning counter of the number of cells transmitted on port B.

Table 100 - Port B Cell Departure Counter Low Register

Address: 358h Label: portb_overflow0 Reset Value: 0000h			
Label	Bit Position	Type	Description
ib_rx_cell_max	4:0	RW	If the cell fill of the RX SAR output FIFO becomes greater than this value, cells from the port B input FIFO will be blocked. 0h = no backpressure
ib_oa_cell_max	9:5	RW	If the cell fill of the Port A output FIFO becomes greater than this value, cells from the port B input FIFO will be blocked. 0h = no backpressure
ib_ob_cell_max	14:10	RW	If the cell fill of the Port B output FIFO becomes greater than this value, cells from the port B input FIFO will be blocked. 0h = no backpressure
reserved	15	RW	Reserved. Must always be "0"

Table 101 - Port B Overflow0 Register

Address: 35Ah Label: portb_overflow1 Reset Value: 0000h			
Label	Bit Position	Type	Description
ib_oc_cell_max	4:0	RW	If the cell fill of the Port C output FIFO becomes greater than this value, cells from the port B input FIFO will be blocked. 0h = no backpressure
reserved	15:5	RW	Reserved. Must always be "0000_0000_000"

Table 102 - Port B Overflow1 Register

Address: 360h Label: portc_look_up_base Reset Value: 0000h			
Label	Bit Position	Type	Description
lutc_base	15:0	RW	Bits 19:4 of the address of the look-up table for port C.

Table 103 - Port C Look Up Table Register

Address: 362h Label: portc_num_vpi_vci_bits Reset Value: 0000h			
Label	Bit Position	Type	Description
num_vpi_vci_bits	15:0	RW	Indicates the total number of bits that are used to decode the look-up address for port C. 0001h = 1 bit used, FFFFh = 16 bits used. When subtracted from vci_n, this indicates the number of VPI bits used.

Table 104 - Port C VPI/VCI Identification Register

Address: 364h Label: portc_concatenation Reset Value: 0000h			
Label	Bit Position	Type	Description
vci_nc	4:0	RW	Indicates the number of VCI bits used to decode the look-up address for port C.
reserved	15:5	RW	Reserved. Must always be "0000_0000_000"

Table 105 - Port C Concatenation Register

Address: 368h Label: portc_vpi_match Reset Value: 0000h			
Label	Bit Position	Type	Description
vpi_matchc	11:0	RW	For a cell from port C to be considered valid, any bits in its VPI whose corresponding bits in reg 34Ah are '1' must have the value contained in this register.

Table 106 - Port C VPI Match Register

Address: 368h Label: portc_vpi_match Reset Value: 0000h			
Label	Bit Position	Type	Description
reserved	15:12	RW	Reserved. Must always be "0000"

Table 106 - Port C VPI Match Register

Address: 36Ah Label: portc_vpi_mask Reset Value: 0000h			
Label	Bit Position	Type	Description
vpi_maskc	11:0	RW	For a cell from port C to be considered valid, any bits in its VPI whose corresponding bits in this register are '1' must have the value contained in reg 348h.
reserved	15:12	RW	Reserved. Must always be "0000"

Table 107 - Port C VPI Mask Register

Address: 36Ch Label: portc_vci_match Reset Value: 0000h			
Label	Bit Position	Type	Description
vci_matchc	15:0	RW	For a cell from port C to be considered valid, any bits in its VCI whose corresponding bits in reg 34Eh are '1' must have the value contained in this register.

Table 108 - Port C VCI Match Register

Address: 36Eh Label: portc_vci_mask Reset Value: 0000h			
Label	Bit Position	Type	Description
vci_maskc	15:0	RW	For a cell from port C to be considered valid, any bits in its VCI whose corresponding bits in this register are '1' must have the value contained in reg 34Ch.

Table 109 - Port C VCI Match Register

Address: 370h Label: portc_cell_arrival_high Reset Value: 0000h			
Label	Bit Position	Type	Description
ic_arr[31:16]	15:0	CNT	Freerunning counter of the number of cells received on port C.

Table 110 - Port C Cell Arrival Counter High Register

Address: 372h Label: portc_cell_arrival_low Reset Value: 0000h			
Label	Bit Position	Type	Description
ic_arr[15:0]	15:0	CNT	Freerunning counter of the number of cells received on port C.

Table 111 - Port C Cell Arrival Counter Low Register

Address: 374h Label: portc_cell_departure_high Reset Value: 0000h			
Label	Bit Position	Type	Description
oc_dep[31:16]	15:0	CNT	Freerunning counter of the number of cells transmitted on port C.

Table 112 - Port C Cell Departure Counter High Register

Address: 376h Label: portc_cell_departure_low Reset Value: 0000h			
Label	Bit Position	Type	Description
oc_dep[15:0]	15:0	CNT	Freerunning counter of the number of cells transmitted on port C.

Table 113 - Port C Cell Departure Counter Low Register

Address: 378h Label: portc_overflow0 Reset Value: 0000h			
Label	Bit Position	Type	Description
ic_rx_cell_max	4:0	RW	If the cell fill of the RX SAR output FIFO becomes greater than this value, cells from the port C input FIFO will be blocked. 0h = no backpressure
ic_oa_cell_max	9:5	RW	If the cell fill of the Port A output FIFO becomes greater than this value, cells from the port C input FIFO will be blocked. 0h = no backpressure
ic_ob_cell_max	14:10	RW	If the cell fill of the Port B output FIFO becomes greater than this value, cells from the port C input FIFO will be blocked. 0h = no backpressure
reserved	15	RW	Reserved. Must always be "0"

Table 114 - Port C Overflow0 Register

Address: 37Ah Label: portc_overflow1 Reset Value: 0000h			
Label	Bit Position	Type	Description
ic_oc_cell_max	4:0	RW	If the cell fill of the Port C output FIFO becomes greater than this value, cells from the port C input FIFO will be blocked. 0h = no backpressure
reserved	15:5	RW	Reserved. Must always be "0000_0000_000"

Table 115 - Port C Overflow1 Register

Address: 390h Label: tx_sar_cell_arrival_high Reset Value: 0000h			
Label	Bit Position	Type	Description
tx_arr[31:16]	15:0	CNT	Bits [31:16] of TX SAR arrival cell counter. Counts the number of cells received by UTOPIA from the TX SAR

Table 116 - TX_SAR Cell Arrival Counter High Register

Address: 392h Label: tx_sar_cell_arrival_low Reset Value: 0000h			
Label	Bit Position	Type	Description
tx_arr[15:0]	15:0	CNT	Bits [15:0] of TX SAR arrival cell counter. Counts the number of cells received by UTOPIA from the TX SAR

Table 117 - TX_SAR Cell Arrival Counter Low Register

Address: 394h Label: rx_sar_cell_departure_high Reset Value: 0000h			
Label	Bit Position	Type	Description
rx_dep[31:16]	15:0	CNT	Bits [31:16] of RX SAR departure cell counter. Counts the number of cells sent to the RX SAR from UTOPIA

Table 118 - RX_SAR Cell Departure Counter High Register

Address: 396h Label: rx_sar_cell_departure_low Reset Value: 0000h			
Label	Bit Position	Type	Description
rx_dep[15:0]	15:0	CNT	Bits [15:0] of RX SAR departure cell counter. Counts the number of cells sent to the RX SAR from UTOPIA

Table 119 - RX_SAR Cell Departure Counter Low Register

Address: 398h Label: tx_sar_overflow Reset Value: 0000h			
Label	Bit Position	Type	Description
tx_rx_cell_max	4:0	RW	If the cell fill of the RX SAR output FIFO becomes greater than this value, cells from the TX SAR input FIFO will be blocked. 0h = no backpressure
tx_oa_cell_max	9:5	RW	If the cell fill of the Port A output FIFO becomes greater than this value, cells from the TX SAR input FIFO will be blocked. 0h = no backpressure
tx_ob_cell_max	14:10	RW	If the cell fill of the Port B output FIFO becomes greater than this value, cells from the TX SAR input FIFO will be blocked. 0h = no backpressure
reserved	15	RW	Reserved. Must always be "0"

Table 120 - TX_SAR Overflow0 Register

Address: 39Ah Label: tx_sar_overflow Reset Value: 0000h			
Label	Bit Position	Type	Description
tx_oc_cell_max	4:0	RW	If the cell fill of the Port C output FIFO becomes greater than this value, cells from the TX SAR input FIFO will be blocked. 0h = no backpressure
reserved	15:5	RW	Reserved. Must always be "0000_0000_000"

Table 121 - TX_SAR Overflow1 Register

Address: 3A0h Label: hec_byte_control Reset Value: 0055h			
Label	Bit Position	Type	Description
hec_mask	7:0	RW	Value by which the HEC generated on UTOPIA will be XORed before being transmitted. Should match the value used by the PHY.
reserved	15:8	RW	Reserved. Must always be "0000_0000_0"

Table 122 - HEC Byte Control Register

Address: 3A2h Label: unknown_header_routing Reset Value: 0000h			
Label	Bit Position	Type	Description
rx_a_ncr	3:0	RW	Normal cell routing for unknow cells received on port A. "xxx1" = Port A, "xx1x" = Port B, "x1xx" = Port C, "1xxx" RX SAR. Cells can be broadcast to multiple destinations by setting multiple bits in this field to '1'.
rx_b_ncr	7:4	RW	Normal cell routing for unknow cells received on port B. "xxx1" = Port A, "xx1x" = Port B, "x1xx" = Port C, "1xxx" RX SAR. Cells can be broadcast to multiple destinations by setting multiple bits in this field to '1'.
rx_c_ncr	11:8	RW	Normal cell routing for unknow cells received on port C. "xxx1" = Port A, "xx1x" = Port B, "x1xx" = Port C, "1xxx" RX SAR. Cells can be broadcast to multiple destinations by setting multiple bits in this field to '1'.
reserved	15:12	RW	Reserved. Must always be "0000"

Table 123 - Unknown Header Routing Register

Address: 3A4h Label: unknown_oam_routing Reset Value: 0000h			
Label	Bit Position	Type	Description
rx_a_ocr	3:0	RW	OAM cell routing for unknow cells received on port A. "xxx1" = Port A, "xx1x" = Port B, "x1xx" = Port C, "1xxx" RX SAR. Cells can be broadcast to multiple destinations by setting multiple bits in this field to '1'.
rx_b_ocr	7:4	RW	OAM cell routing for unknow cells received on port B. "xxx1" = Port A, "xx1x" = Port B, "x1xx" = Port C, "1xxx" RX SAR. Cells can be broadcast to multiple destinations by setting multiple bits in this field to '1'.
rx_c_ocr	11:8	RW	OAM cell routing for unknow cells received on port C. "xxx1" = Port A, "xx1x" = Port B, "x1xx" = Port C, "1xxx" RX SAR. Cells can be broadcast to multiple destinations by setting multiple bits in this field to '1'.
reserved	15:12	RW	Reserved. Must always be "0000"

Table 124 - Unknown OAM Routing Register

Address: 3C0h Label: gpio_input0 Reset Value: 0000h			
Label	Bit Position	Type	Description
tx_a_data_input	7:0	RO	Current level of tx_a_data pins [15:8]
rx_a_data_input	15:8	RO	Current level of rx_a_data pins [15:8]

Table 125 - GPIO Input0 Register

Address: 3C2h Label: gpio_input1 Reset Value: 0000h			
Label	Bit Position	Type	Description
tx_b_data_input	7:0	RO	Current level of tx_b_data pins [15:8]
rx_b_data_input	15:8	RO	Current level of rx_b_data pins [15:8]

Table 126 - GPIO Input1 Register

Address: 3C4h Label: gpio_input2 Reset Value: 0000h			
Label	Bit Position	Type	Description
phya_alm_input	0	RO	Current level of phya_alm pin
phyb_alm_input	1	RO	Current level of phya_alm pin
phya_tx_led_input	2	RO	Current level of phya_tx_led pin
phya_rx_led_input	3	RO	Current level of phya_rx_led pin
phyb_tx_led_input	4	RO	Current level of phyb_tx_led pin
phyb_rx_led_input	5	RO	Current level of phyb_rx_led pin
reserved	15:6	RO	Reserved. Always read as "0000_0000_00"

Table 127 - GPIO Input2 Register

Address: 3C8h Label: txa_data_status Reset Value: 0000h			
Label	Bit Position	Type	Description
txa_data8_rise	0	ROL	This bit is set when corresponding pin changes from '0' to '1'
txa_data8_fall	1	ROL	This bit is set when corresponding pin changes from '1' to '0'
txa_data9_rise	2	ROL	This bit is set when corresponding pin changes from '0' to '1'
txa_data9_fall	3	ROL	This bit is set when corresponding pin changes from '1' to '0'
txa_data10_rise	4	ROL	This bit is set when corresponding pin changes from '0' to '1'
txa_data10_fall	5	ROL	This bit is set when corresponding pin changes from '1' to '0'
txa_data11_rise	6	ROL	This bit is set when corresponding pin changes from '0' to '1'
txa_data11_fall	7	ROL	This bit is set when corresponding pin changes from '1' to '0'
txa_data12_rise	8	ROL	This bit is set when corresponding pin changes from '0' to '1'
txa_data12_fall	9	ROL	This bit is set when corresponding pin changes from '1' to '0'
txa_data13_rise	10	ROL	This bit is set when corresponding pin changes from '0' to '1'
txa_data13_fall	11	ROL	This bit is set when corresponding pin changes from '1' to '0'
txa_data14_rise	12	ROL	This bit is set when corresponding pin changes from '0' to '1'
txa_data14_fall	13	ROL	This bit is set when corresponding pin changes from '1' to '0'
txa_data15_rise	14	ROL	This bit is set when corresponding pin changes from '0' to '1'
txa_data15_fall	15	ROL	This bit is set when corresponding pin changes from '1' to '0'

Table 128 - TXA Data Status Register

Address: 3CAh Label: txa_data_status_ie Reset Value: 0000h			
Label	Bit Position	Type	Description
txa_data8_rise_ie	0	IE	When '1' and the corresponding status bit is '1', an interrupt will be generated.
txa_data8_fall_ie	1	IE	When '1' and the corresponding status bit is '1', an interrupt will be generated.
txa_data9_rise_ie	2	IE	When '1' and the corresponding status bit is '1', an interrupt will be generated.
txa_data9_fall_ie	3	IE	When '1' and the corresponding status bit is '1', an interrupt will be generated.
txa_data10_rise_ie	4	IE	When '1' and the corresponding status bit is '1', an interrupt will be generated.
txa_data10_fall_ie	5	IE	When '1' and the corresponding status bit is '1', an interrupt will be generated.
txa_data11_rise_ie	6	IE	When '1' and the corresponding status bit is '1', an interrupt will be generated.
txa_data11_fall_ie	7	IE	When '1' and the corresponding status bit is '1', an interrupt will be generated.
txa_data12_rise_ie	8	IE	When '1' and the corresponding status bit is '1', an interrupt will be generated.
txa_data12_fall_ie	9	IE	When '1' and the corresponding status bit is '1', an interrupt will be generated.
txa_data13_rise_ie	10	IE	When '1' and the corresponding status bit is '1', an interrupt will be generated.
txa_data13_fall_ie	11	IE	When '1' and the corresponding status bit is '1', an interrupt will be generated.
txa_data14_rise_ie	12	IE	When '1' and the corresponding status bit is '1', an interrupt will be generated.
txa_data14_fall_ie	13	IE	When '1' and the corresponding status bit is '1', an interrupt will be generated.
txa_data15_rise_ie	14	IE	When '1' and the corresponding status bit is '1', an interrupt will be generated.
txa_data15_fall_ie	15	IE	When '1' and the corresponding status bit is '1', an interrupt will be generated.

Table 129 - TXA Data Interrupt Enable Register

Address: 3CCh Label: rxa_data_status Reset Value: 0000h			
Label	Bit Position	Type	Description
rx_data8_rise	0	ROL	This bit is set when corresponding pin changes from '0' to '1'
rx_data8_fall	1	ROL	This bit is set when corresponding pin changes from '1' to '0'
rx_data9_rise	2	ROL	This bit is set when corresponding pin changes from '0' to '1'
rx_data9_fall	3	ROL	This bit is set when corresponding pin changes from '1' to '0'
rx_data10_rise	4	ROL	This bit is set when corresponding pin changes from '0' to '1'
rx_data10_fall	5	ROL	This bit is set when corresponding pin changes from '1' to '0'
rx_data11_rise	6	ROL	This bit is set when corresponding pin changes from '0' to '1'
rx_data11_fall	7	ROL	This bit is set when corresponding pin changes from '1' to '0'
rx_data12_rise	8	ROL	This bit is set when corresponding pin changes from '0' to '1'
rx_data12_fall	9	ROL	This bit is set when corresponding pin changes from '1' to '0'
rx_data13_rise	10	ROL	This bit is set when corresponding pin changes from '0' to '1'
rx_data13_fall	11	ROL	This bit is set when corresponding pin changes from '1' to '0'
rx_data14_rise	12	ROL	This bit is set when corresponding pin changes from '0' to '1'
rx_data14_fall	13	ROL	This bit is set when corresponding pin changes from '1' to '0'
rx_data15_rise	14	ROL	This bit is set when corresponding pin changes from '0' to '1'
rx_data15_fall	15	ROL	This bit is set when corresponding pin changes from '1' to '0'

Table 130 - RXA Data Status Register

Address: 3CEh Label: rxa_data_status_ie Reset Value: 0000h			
Label	Bit Position	Type	Description
rx_data8_rise_ie	0	IE	When '1' and the corresponding status bit is '1', an interrupt will be generated.
rx_data8_fall_ie	1	IE	When '1' and the corresponding status bit is '1', an interrupt will be generated.
rx_data9_rise_ie	2	IE	When '1' and the corresponding status bit is '1', an interrupt will be generated.

Table 131 - RXA Data Interrupt Enable Register

Address: 3CEh Label: rxa_data_status_ie Reset Value: 0000h			
Label	Bit Position	Type	Description
rx_data9_fall_ie	3	IE	When '1' and the corresponding status bit is '1', an interrupt will be generated.
rx_data10_rise_ie	4	IE	When '1' and the corresponding status bit is '1', an interrupt will be generated.
rx_data10_fall_ie	5	IE	When '1' and the corresponding status bit is '1', an interrupt will be generated.
rx_data11_rise_ie	6	IE	When '1' and the corresponding status bit is '1', an interrupt will be generated.
rx_data11_fall_ie	7	IE	When '1' and the corresponding status bit is '1', an interrupt will be generated.
rx_data12_rise_ie	8	IE	When '1' and the corresponding status bit is '1', an interrupt will be generated.
rx_data12_fall_ie	9	IE	When '1' and the corresponding status bit is '1', an interrupt will be generated.
rx_data13_rise_ie	10	IE	When '1' and the corresponding status bit is '1', an interrupt will be generated.
rx_data13_fall_ie	11	IE	When '1' and the corresponding status bit is '1', an interrupt will be generated.
rx_data14_rise_ie	12	IE	When '1' and the corresponding status bit is '1', an interrupt will be generated.
rx_data14_fall_ie	13	IE	When '1' and the corresponding status bit is '1', an interrupt will be generated.
rx_data15_rise_ie	14	IE	When '1' and the corresponding status bit is '1', an interrupt will be generated.
rx_data15_fall_ie	15	IE	When '1' and the corresponding status bit is '1', an interrupt will be generated.

Table 131 - RXA Data Interrupt Enable Register (continued)

Address: 3D0h Label: txb_data_status Reset Value: 0000h			
Label	Bit Position	Type	Description
txb_data8_rise	0	ROL	This bit is set when corresponding pin changes from '0' to '1'
txb_data8_fall	1	ROL	This bit is set when corresponding pin changes from '1' to '0'
txb_data9_rise	2	ROL	This bit is set when corresponding pin changes from '0' to '1'

Table 132 - TXB Data Status Register

Address: 3D0h Label: txb_data_status Reset Value: 0000h			
Label	Bit Position	Type	Description
txb_data9_fall	3	ROL	This bit is set when corresponding pin changes from '1' to '0'
txb_data10_rise	4	ROL	This bit is set when corresponding pin changes from '0' to '1'
txb_data10_fall	5	ROL	This bit is set when corresponding pin changes from '1' to '0'
txb_data11_rise	6	ROL	This bit is set when corresponding pin changes from '0' to '1'
txb_data11_fall	7	ROL	This bit is set when corresponding pin changes from '1' to '0'
txb_data12_rise	8	ROL	This bit is set when corresponding pin changes from '0' to '1'
txb_data12_fall	9	ROL	This bit is set when corresponding pin changes from '1' to '0'
txb_data13_rise	10	ROL	This bit is set when corresponding pin changes from '0' to '1'
txb_data13_fall	11	ROL	This bit is set when corresponding pin changes from '1' to '0'
txb_data14_rise	12	ROL	This bit is set when corresponding pin changes from '0' to '1'
txb_data14_fall	13	ROL	This bit is set when corresponding pin changes from '1' to '0'
txb_data15_rise	14	ROL	This bit is set when corresponding pin changes from '0' to '1'
txb_data15_fall	15	ROL	This bit is set when corresponding pin changes from '1' to '0'

Table 132 - TXB Data Status Register (continued)

Address: 3D2h Label: txb_data_status_ie Reset Value: 0000h			
Label	Bit Position	Type	Description
txb_data8_rise_ie	0	IE	When '1' and the corresponding status bit is '1', an interrupt will be generated.
txb_data8_fall_ie	1	IE	When '1' and the corresponding status bit is '1', an interrupt will be generated.
txb_data9_rise_ie	2	IE	When '1' and the corresponding status bit is '1', an interrupt will be generated.
txb_data9_fall_ie	3	IE	When '1' and the corresponding status bit is '1', an interrupt will be generated.
txb_data10_rise_ie	4	IE	When '1' and the corresponding status bit is '1', an interrupt will be generated.

Table 133 - TXB Data Interrupt Enable Register

Address: 3D2h Label: txb_data_status_ie Reset Value: 0000h			
Label	Bit Position	Type	Description
txb_data10_fall_ie	5	IE	When '1' and the corresponding status bit is '1', an interrupt will be generated.
txb_data11_rise_ie	6	IE	When '1' and the corresponding status bit is '1', an interrupt will be generated.
txb_data11_fall_ie	7	IE	When '1' and the corresponding status bit is '1', an interrupt will be generated.
txb_data12_rise_ie	8	IE	When '1' and the corresponding status bit is '1', an interrupt will be generated.
txb_data12_fall_ie	9	IE	When '1' and the corresponding status bit is '1', an interrupt will be generated.
txb_data13_rise_ie	10	IE	When '1' and the corresponding status bit is '1', an interrupt will be generated.
txb_data13_fall_ie	11	IE	When '1' and the corresponding status bit is '1', an interrupt will be generated.
txb_data14_rise_ie	12	IE	When '1' and the corresponding status bit is '1', an interrupt will be generated.
txb_data14_fall_ie	13	IE	When '1' and the corresponding status bit is '1', an interrupt will be generated.
txb_data15_rise_ie	14	IE	When '1' and the corresponding status bit is '1', an interrupt will be generated.
txb_data15_fall_ie	15	IE	When '1' and the corresponding status bit is '1', an interrupt will be generated.

Table 133 - TXB Data Interrupt Enable Register (continued)

Address: 3D4h Label: rxb_data_status Reset Value: 0000h			
Label	Bit Position	Type	Description
rxb_data8_rise	0	ROL	This bit is set when corresponding pin changes from '0' to '1'
rxb_data8_fall	1	ROL	This bit is set when corresponding pin changes from '1' to '0'
rxb_data9_rise	2	ROL	This bit is set when corresponding pin changes from '0' to '1'
rxb_data9_fall	3	ROL	This bit is set when corresponding pin changes from '1' to '0'
rxb_data10_rise	4	ROL	This bit is set when corresponding pin changes from '0' to '1'
rxb_data10_fall	5	ROL	This bit is set when corresponding pin changes from '1' to '0'
rxb_data11_rise	6	ROL	This bit is set when corresponding pin changes from '0' to '1'
rxb_data11_fall	7	ROL	This bit is set when corresponding pin changes from '1' to '0'
rxb_data12_rise	8	ROL	This bit is set when corresponding pin changes from '0' to '1'
rxb_data12_fall	9	ROL	This bit is set when corresponding pin changes from '1' to '0'
rxb_data13_rise	10	ROL	This bit is set when corresponding pin changes from '0' to '1'
rxb_data13_fall	11	ROL	This bit is set when corresponding pin changes from '1' to '0'
rxb_data14_rise	12	ROL	This bit is set when corresponding pin changes from '0' to '1'
rxb_data14_fall	13	ROL	This bit is set when corresponding pin changes from '1' to '0'
rxb_data15_rise	14	ROL	This bit is set when corresponding pin changes from '0' to '1'
rxb_data15_fall	15	ROL	This bit is set when corresponding pin changes from '1' to '0'

Table 134 - RXB Data Status Register

Address: 3D6h Label: rxb_data_status_ie Reset Value: 0000h			
Label	Bit Position	Type	Description
rxb_data8_rise_ie	0	IE	When '1' and the corresponding status bit is '1', an interrupt will be generated.
rxb_data8_fall_ie	1	IE	When '1' and the corresponding status bit is '1', an interrupt will be generated.
rxb_data9_rise_ie	2	IE	When '1' and the corresponding status bit is '1', an interrupt will be generated.
rxb_data9_fall_ie	3	IE	When '1' and the corresponding status bit is '1', an interrupt will be generated.

Table 135 - RXB Data Interrupt Enable Register

rxb_data10_rise_ie	4	IE	When '1' and the corresponding status bit is '1', an interrupt will be generated.
rxb_data10_fall_ie	5	IE	When '1' and the corresponding status bit is '1', an interrupt will be generated.
rxb_data11_rise_ie	6	IE	When '1' and the corresponding status bit is '1', an interrupt will be generated.
rxb_data11_fall_ie	7	IE	When '1' and the corresponding status bit is '1', an interrupt will be generated.
rxb_data12_rise_ie	8	IE	When '1' and the corresponding status bit is '1', an interrupt will be generated.
rxb_data12_fall_ie	9	IE	When '1' and the corresponding status bit is '1', an interrupt will be generated.
rxb_data13_rise_ie	10	IE	When '1' and the corresponding status bit is '1', an interrupt will be generated.
rxb_data13_fall_ie	11	IE	When '1' and the corresponding status bit is '1', an interrupt will be generated.
rxb_data14_rise_ie	12	IE	When '1' and the corresponding status bit is '1', an interrupt will be generated.
rxb_data14_fall_ie	13	IE	When '1' and the corresponding status bit is '1', an interrupt will be generated.
rxb_data15_rise_ie	14	IE	When '1' and the corresponding status bit is '1', an interrupt will be generated.
rxb_data15_fall_ie	15	IE	When '1' and the corresponding status bit is '1', an interrupt will be generated.

Table 135 - RXB Data Interrupt Enable Register (continued)

Address: 3D8h			
Label: gpio_status			
Reset Value: 0000h			
Label	Bit Position	Type	Description
phy_a_alm_rise	0	ROL	This bit is set when corresponding pin changes from '0' to '1'
phy_a_alm_fall	1	ROL	This bit is set when corresponding pin changes from '1' to '0'
phy_b_alm_rise	2	ROL	This bit is set when corresponding pin changes from '0' to '1'
phy_b_alm_fall	3	ROL	This bit is set when corresponding pin changes from '1' to '0'
phy_a_tx_led_rise	4	ROL	This bit is set when corresponding pin changes from '0' to '1'
phy_a_tx_led_fall	5	ROL	This bit is set when corresponding pin changes from '1' to '0'
phy_a_rx_led_rise	6	ROL	This bit is set when corresponding pin changes from '0' to '1'
phy_a_rx_led_fall	7	ROL	This bit is set when corresponding pin changes from '1' to '0'
phy_b_tx_led_rise	8	ROL	This bit is set when corresponding pin changes from '0' to '1'

Table 136 - GPIO Status Register

Address: 3D8h Label: gpio_status Reset Value: 0000h			
Label	Bit Position	Type	Description
phyb_tx_led_fall	9	ROL	This bit is set when corresponding pin changes from '1' to '0'
phyb_rx_led_rise	10	ROL	This bit is set when corresponding pin changes from '0' to '1'
phyb_rx_led_fall	11	ROL	This bit is set when corresponding pin changes from '1' to '0'
reserved	15:12	ROL	Reserved. Always read as "0000"

Table 136 - GPIO Status Register (continued)

Address: 3DAh Label: gpio_status_ie Reset Value: 0000h			
Label	Bit Position	Type	Description
phya_alm_rise_ie	0	IE	When '1' and the corresponding status bit is '1', an interrupt will be generated.
phya_alm_fall_ie	1	IE	When '1' and the corresponding status bit is '1', an interrupt will be generated.
phyb_alm_rise_ie	2	IE	When '1' and the corresponding status bit is '1', an interrupt will be generated.
phyb_alm_fall_ie	3	IE	When '1' and the corresponding status bit is '1', an interrupt will be generated.
phya_tx_led_rise_ie	4	IE	When '1' and the corresponding status bit is '1', an interrupt will be generated.
phya_tx_led_fall_ie	5	IE	When '1' and the corresponding status bit is '1', an interrupt will be generated.
phya_rx_led_rise_ie	6	IE	When '1' and the corresponding status bit is '1', an interrupt will be generated.
phya_rx_led_fall_ie	7	IE	When '1' and the corresponding status bit is '1', an interrupt will be generated.
phyb_tx_led_rise_ie	8	IE	When '1' and the corresponding status bit is '1', an interrupt will be generated.
phyb_tx_led_fall_ie	9	IE	When '1' and the corresponding status bit is '1', an interrupt will be generated.
phyb_rx_led_rise_ie	10	IE	When '1' and the corresponding status bit is '1', an interrupt will be generated.
phyb_rx_led_fall_ie	11	IE	When '1' and the corresponding status bit is '1', an interrupt will be generated.

Table 137 - GPIO Status Register

Address: 3DAh Label: gpio_status_ie Reset Value: 0000h			
Label	Bit Position	Type	Description
reserved	15:12	RO	Reserved. Always read as "0000"

Table 137 - GPIO Status Register (continued)

Address: 3E0h Label: gpio_output0 Reset Value: 0000h			
Label	Bit Position	Type	Description
txa_data_output	7:0	RW	This is the value sent out on the pins txa_data [15:8], used in conjunction with the OE bit
reserved	15:8	RW	Reserved. Must always be "0000_0000"

Table 138 - GPIO Output0 Register

Address: 3E2h Label: gpio_output1 Reset Value: 0000h			
Label	Bit Position	Type	Description
txb_data_output	7:0	RW	This is the value sent out on the pins txb_data [15:8], used in conjunction with the OE bit
reserved	15:8	RW	Reserved. Must always be "0000_0000"

Table 139 - GPIO Output1 Register

Address: 3E4h Label: gpio_output2 Reset Value: 0000h			
Label	Bit Position	Type	Description
phya_tx_led_output	0	RW	This is the value sent out on the corresponding pin, used in conjunction with the OE bit
phya_rx_led_output	1	RW	This is the value sent out on the corresponding pin, used in conjunction with the OE bit

Table 140 - GPIO Output2 Register

Address: 3E4h Label: gpio_output2 Reset Value: 0000h			
Label	Bit Position	Type	Description
phyb_tx_led_output	2	RW	This is the value sent out on the corresponding pin, used in conjunction with the OE bit
phyb_rx_led_output	3	RW	This is the value sent out on the corresponding pin, used in conjunction with the OE bit
reserved	15:4	RW	Reserved. Must always be "0000_0000_0000"

Table 140 - GPIO Output2 Register (continued)

Address: 3E8h Label: gpio_oe0 Reset Value: 0000h			
Label	Bit Position	Type	Description
txa_data_oe	7:0	RW	This is OE bit used to drive the txa_data [15:8] pins
reserved	15:8	RW	Reserved. Must always be "0000_0000"

Table 141 - GPIO Output Enable0 Register

Address: 3EAh Label: gpio_oe1 Reset Value: 0000h			
Label	Bit Position	Type	Description
txb_data_oe	7:0	RW	This is OE bit used to drive the txb_data [15:8] pins
reserved	15:8	RW	Reserved. Must always be "0000_0000"

Table 142 - GPIO Output Enable1 Register

Address: 3ECh Label: gpio_oe2 Reset Value: 0000h			
Label	Bit Position	Type	Description
phya_tx_led_oe	0	RW	This is OE bit used to drive the corresponding pin
phya_rx_led_oe	1	RW	This is OE bit used to drive the corresponding pin
phyb_tx_led_oe	2	RW	This is OE bit used to drive the corresponding pin
phyb_rx_led_oe	3	RW	This is OE bit used to drive the corresponding pin
reserved	15:4	RW	Reserved. Must always be "0000_0000_0000"

Table 143 - GPIO Output Enable2 Register

5.5.4 TDM Registers

Address: 400h Label: control Reset Value: 0000h			
Label	Bit Position	Type	Description
global_oe	0	RW	'0' = ct_d[31:0] forced tri-state; '1' = ct_d[31:0] may be driven.
h100_data_loopback	1	RW	'0' = no ct_d[31:0] loopback; '1' = ct_d[31:0] loopback. For test only.
tdmie_enable	2	RW	'0' disables TDM process. Should only be set to '1' when CAM has been programmed
stream_mode	4:3	RW	"00" = 32 streams, "01" = 16 streams, "10" = 4 streams, "11" = reserved. This register is only used for tests: in real operation, it should be left to "00" (32 streams).
reserved	14:5	RW	Reserved. Must always be "0000_0000_00"
test_status	15	TS	When '1', all the status bits in the register will be set.

Table 144 - TDM Control Register

Address: 402h Label: status0 Reset Value: 0000h			
Label	Bit Position	Type	Description
tdm_out_of_bandwidth0	0	ROL	Indicates that the TDM state machine is out of bandwidth. Fatal chip error, usually due to mclk frequency being too low.
cut_vc_detected	1	ROL	This bit is set when 255 underruns are detected on a VC whose CAM entry has an enabled "Cut VC status enable" bit
underrun_detected	2	ROL	Underrun reported on a voice channel on the ATM link.
cas_underrun_detected	3	ROL	Underrun reported on CAS bits on the ATM link.
rdatamem_overflow	4	ROL	Overflow in the TDM RX internal data memory. Fatal chip error.
tdmtxpip_overflow	5	ROL	Overflow in the TDM TX data memory access cache. Fatal chip error.
tdmrxpip_overflow	6	ROL	Overflow in the TDM RX data memory access cache. Fatal chip error.
reserved	15:7	ROL	Reserved. Always read as "0000_0000_0"

Table 145 - TDM Status Register

Address: 408h Label: cut_vc_tsst Reset Value: 0000h			
Label	Bit Position	Type	Description
tsst_number_cut_vc	11:0	RO	Indicates the TSST on which the last cut VC error occurred.
reserved	15:12	RO	Reserved. Always read as "0000"

Table 146 - Cut VC TSST Register

Address: 40Ah Label: underrun_tsst Reset Value: 0000h			
Label	Bit Position	Type	Description
tsst_number_underrun	11:0	RO	Indicates the TSST on which the last underrun error occurred.
reserved	15:12	RO	Reserved. Always read as "0000"

Table 147 - TSST Underrun Register

Address: 40Ch Label: cas_underrun_tsst Reset Value: 0000h			
Label	Bit Position	Type	Description
tsst_number_cas_underrun	11:0	RO	Indicates the TSST on which the last CAS underrun error occurred.
reserved	15:12	RO	Reserved. Always read as "0000"

Table 148 - TSST CAS Underrun Register

Address: 410h Label: tdmint_reg0 Reset Value: 0000h			
Label	Bit Position	Type	Description
h100_samp_clk_delay_flops	3:0	RW	Number of flops used = 8 + value of this register. "1111" is reserved for selecting falling edge ct_c8 clock.
h100_samp_clk_delay_buff	7:4	RW	"1111" is reserved for selecting rising edge ct_c8 clock
h100_oe_clk_delay_flops	11:8	RW	Number of flops used = 8 + value of this register
h100_oe_clk_delay_buff	15:12	RW	Number of delay buffers used in the delay chain.

Table 149 - TDM Interrupt 0 Register

Address: 412h Label: tdmint_reg1 Reset Value: 0000h			
Label	Bit Position	Type	Description
h100_ts_counter_timeout	6:0	RW	Number of mclk cycles in 8 ct_c8 clock cycles - 10%
h100_oe_override_disable	7	RW	'1' = do not tri-state the ct_d pin after every timeslot. To respect the H.100 standard, this should be left to '0'.
dstream_0_3_freq	9:8	RW	ct_d[3:0] stream clock speed. "00" = 2.048 Mhz; "01" = 4.096 MHz; "10" = 8.192 MHz; "11" = reserved.
dstream_4_7_freq	11:10	RW	ct_d[7:4] stream clock speed. "00" = 2.048 Mhz; "01" = 4.096 MHz; "10" = 8.192 MHz; "11" = reserved.
dstream_8_11_freq	13:12	RW	ct_d[11:8] stream clock speed. "00" = 2.048 Mhz; "01" = 4.096 MHz; "10" = 8.192 MHz; "11" = reserved.

Table 150 - TDM Interrupt 1 Register

Address: 412h Label: tdmint_reg1 Reset Value: 0000h			
Label	Bit Position	Type	Description
dstream_12_15_freq	15:14	RW	ct_d[15:12] stream clock speed. "00" = 2.048 Mhz; "01" = 4.096 Mhz; "10" = 8.192 Mhz; "11" = reserved.

Table 150 - TDM Interrupt 1 Register (continued)

Address: 420h Label: tdmie_misc Reset Value: 00FFh			
Label	Bit Position	Type	Description
null_byte	7:0	RW	Null byte with which the chip will pad if underruns occur and null byte padding is chosen.
cas_enable_position	10:8	RW	Position of the CAS enable bit within the byte on the TDM bus. The CAS nibble will be contained in the nibble in which the enable is not present. For example, if the enable is contained in bit 6, then the nibble will be in bits 3:0.
cas_enable_polarity	11	RW	Polarity of the CAS enable bit on the TDM bus.
reserved	15:12	RW	Reserved. Must always be "0000"

Table 151 - TDM Interrupt Enable Misc. Register

Address: 460h Label: pnt_ro Reset Value: 0000h			
Label	Bit Position	Type	Description
txsar_write_pnt_pcm_monitor [9:0]	9:0	RO	The current value of the TDM write pointer sent to the TX SAR. Only used for tests.
reserved	15:10	RO	Reserved. Always read as "0000_00"

Table 152 - TDM Write Pointer 0 Register

Address: 462h Label: txsar_pnt_fire Reset Value: 0000h			
Label	Bit Position	Type	Description
txsar_write_pnt_insert[9:0]	9:0	RW	The test value of the TDM write pointer sent to the TX SAR. Only used for tests.
txsar_write_pnt_insert_ena	10	RW	When '1', the above pointer will be sent to the TX SAR instead of the valid pointer. Only used for tests.
reserved	15:11	RO	Reserved. Always read as "0000_00"

Table 153 - TDM Write Pointer 1 Register

Address: 464h Label: rxsar_pnt_fire Reset Value: 0000h			
Label	Bit Position	Type	Description
rxsar_write_pnt_insert[14:0]	14:0	RW	The test value of the TDM read pointer sent to the RX SAR. Only used for tests.
rxsar_write_pnt_insert_ena	15	RW	When '1', the above pointer will be sent to the RX SAR instead of the valid pointer. Only used for tests.

Table 154 - TDM Read Pointer Register

5.5.5 TX_SAR Registers

Address: 500h Label: control Reset Value: 0000h			
Label	Bit Position	Type	Description
reserved	14:0	RO	Reserved. Always read as "0000_0000_0000_000"
test_status	15	TS	When '1', all the status bits in the register will be set.

Table 155 - TX_SAR Control Register

Address: 502h Label: status Reset Value: 0000h			
Label	Bit Position	Type	Description
global_tx_slip	0	ROL	Raised when a bad configuration of the offset field in the TX control structure causes the TX SAR to read data that has not been written yet.
txsarpip_overflow	1	ROL	Overflow in the TX SAR data memory access cache. Fatal chip error.
reserved	15:2	RO	Reserved. Always read as "0000_0000_0000_00"

Table 156 - TX_SAR Status Register

Address: 504h Label: status_ie Reset Value: 0000h			
Label	Bit Position	Type	Description
global_tx_slip_ie	0	IE	When '1' and the corresponding status bit is '1', an interrupt will be generated.
txsarpip_overflow_ie	1	IE	When '1' and the corresponding status bit is '1', an interrupt will be generated.
reserved	15:2	IE	Reserved. Always read as ""0000_0000_0000_00"

Table 157 - TX_SAR Interrupt Enable Register

Address: 506h Label: control1 Reset Value: 0000h			
Label	Bit Position	Type	Description
reset_band_per	0	PUL	Resets the band_per register field.
reserved	15:1	RO	Reserved. Always read as "0000_0000_0000_000"

Table 158 - TX_SAR Control 1 Register

Address: 508h Label: data_cell_read Reset Value: 0000h			
Label	Bit Position	Type	Description
data_read_pnt	13:0	RO	Chip's read pointer to the AAL0 FIFO.
reserved	15:14	RO	Reserved. Always read as "00"

Table 159 - TX_SAR Data Read Pointer Register

Address: 50Ah Label: data_cell_write Reset Value: 0000h			
Label	Bit Position	Type	Description
data_write_pnt	13:0	RW	CPU's write pointer to the AAL0 FIFO.
reserved	15:14	RW	Reserved. Must always be "00"

Table 160 - TX_SAR Data Write Pointer Register

Address: 50Ch Label: data_cell_add Reset Value: 0000h			
Label	Bit Position	Type	Description
data_add	13:0	RW	Bits 19:6 of the address of the FIFO in external memory
reserved	15:14	RW	Reserved. Always read as "00"

Table 161 - TX_SAR Data Address Register

Address: 50Eh Label: data_cell_size Reset Value: 0000h			
Label	Bit Position	Type	Description
data_size	13:0	RW	Size of data cell FIFO in 1 cell increments. All zeros = 16k cells. Minimum 4 cells.
reserved	15:14	RW	Reserved. Must always be "00"

Table 162 - TX_SAR Data Cell Size Register

Address: 510h Label: percentage_of_bandwidth Reset Value: 0000h			
Label	Bit Position	Type	Description
band_per	15:0	RO	Monitor of the maximum number of mclk cycles that it has taken the chip to treat an entire TX SAR frame. If this number is greater than mclk (in Hz) / 8000, some of the frames are overloaded.

Table 163 - Percent of Bandwidth Register

5.5.6 Scheduler Registers

Address: 600h Label: control Reset Value: 0000h			
Label	Bit Position	Type	Description
test_status	15	TS	When '1', all the status bits in the register will be set.

Table 164 - Scheduler Test Status Register

Address: 602h Label: status Reset Value: 0000h			
Label	Bit Position	Type	Description
out_of_band	0	ROL	Indicates that the wheel treatment is more than fr_late frames late. This means that at least some of the frames in the wheels are overloaded.
reserved	15:1	ROL	Reserved. Always read as "0000_0000_0000_000"

Table 165 - Scheduler Status Register

Address: 604h Label: status_ie Reset Value: 0000h			
Label	Bit Position	Type	Description
out_of_band_ie	0	IE	When '1' and the corresponding status bit is '1', an interrupt will be generated.
reserved	15:1	IE	Reserved. Always read as "0000_0000_0000_000"

Table 166 - Scheduler Interrupt Enable Register

Address: 608h Label: frame_latency Reset Value: 0001h			
Label	Bit Position	Type	Description
fr_late	3:0	RW	Number of frames by which the chip is allowed to be late. 0h = illegal.
reserved	15:4	RW	Reserved. Must always be "0000_0000_0000"

Table 167 - Frame Latency Register

Address: 610h Label: wheel_info_0 Reset Value: 0001h			
Label	Bit Position	Type	Description
wheel0_ena	0	RW	Enable for wheel 0.
wheel0_inf	3:1	RW	Configuration of wheel 0. "000" = normal, "100" = T1, "101" = E1, others reserved.
wheel1_ena	4	RW	Enable for wheel 1.
wheel1_inf	7:5	RW	Configuration of wheel 1. "000" = normal, "100" = T1, "101" = E1, others reserved.
wheel2_ena	8	RW	Enable for wheel 2.
wheel2_inf	11:9	RW	Configuration of wheel 2. "000" = normal, "100" = T1, "101" = E1, others reserved.
wheel3_ena	12	RW	Enable for wheel 3.
wheel3_inf	15:13	RW	Configuration of wheel 3. "000" = normal, "100" = T1, "101" = E1, others reserved.

Table 168 - Scheduler Configuration & Enable 0 Register

Address: 612h Label: wheel_inf_1 Reset Value: 0000h			
Label	Bit Position	Type	Description
wheel4_ena	0	RW	Enable for wheel 4.
wheel4_inf	3:1	RW	Configuration of wheel 4. "000" = normal, "100" = T1, "101" = E1, others reserved.

Table 169 - Scheduler Configuration & Enable 1 Register

Address: 612h Label: wheel_inf_1 Reset Value: 0000h			
Label	Bit Position	Type	Description
wheel5_ena	4	RW	Enable for wheel 5.
wheel5_inf	7:5	RW	Configuration of wheel 5. "000" = normal, "100" = T1, "101" = E1, others reserved.
wheel6_ena	8	RW	Enable for wheel 6.
wheel6_inf	11:9	RW	Configuration of wheel 6. "000" = normal, "100" = T1, "101" = E1, others reserved.
wheel7_ena	12	RW	Enable for wheel 7.
wheel7_inf	15:13	RW	Configuration of wheel 7. "000" = normal, "100" = T1, "101" = E1, others reserved.

Table 169 - Scheduler Configuration & Enable 1 Register (continued)

Address: 614h Label: wheel_inf_2 Reset Value: 0000h			
Label	Bit Position	Type	Description
wheel8_ena	0	RW	Enable for wheel 8.
wheel8_inf	3:1	RW	Configuration of wheel 8. "000" = normal, "100" = T1, "101" = E1, others reserved.
wheel9_ena	4	RW	Enable for wheel 9.
wheel9_inf	7:5	RW	Configuration of wheel 9. "000" = normal, "100" = T1, "101" = E1, others reserved.
wheelA_ena	8	RW	Enable for wheel 10.
wheelA_inf	11:9	RW	Configuration of wheel 10. "000" = normal, "100" = T1, "101" = E1, others reserved.
wheelB_ena	12	RW	Enable for wheel 11.
wheelB_inf	15:13	RW	Configuration of wheel 11. "000" = normal, "100" = T1, "101" = E1, others reserved.

Table 170 - Scheduler Configuration & Enable 2 Register

Address: 616h Label: wheel_inf_3 Reset Value: 0000h			
Label	Bit Position	Type	Description
wheelC_ena	0	RW	Enable for wheel 12.
wheelC_inf	3:1	RW	Configuration of wheel 12. "000" = normal, "100" = T1, "101" = E1, others reserved.
wheelD_ena	4	RW	Enable for wheel 13.
wheelD_inf	7:5	RW	Configuration of wheel 13. "000" = normal, "100" = T1, "101" = E1, others reserved.
wheelE_ena	8	RW	Enable for wheel 14.
wheelE_inf	11:9	RW	Configuration of wheel 14. "000" = normal, "100" = T1, "101" = E1, others reserved.
reserved	15:12	RW	Reserved. Must always be "0000"

Table 171 - Scheduler Configuration & Enable 3 Register

5.5.7 RX_SAR Registers

Address: 700h Label: control Reset Value: 0000h			
Label	Bit Position	Type	Description
always_diagnose	0	RW	When '1', an error report structure will be generated for every cell that arrives. Used for tests.
reserved	14:1	RW	Reserved. Must always be "0000_0000_0000_00"
test_status	15	TS	When '1', all the status bits in the register will be set.

Table 172 - RX_SAR Control Register

Address: 702h Label: status Reset Value: 0000h			
Label	Bit Position	Type	Description
rxsarpip_overflow	0	ROL	Overflow in the RX SAR data memory access cache. Fatal chip error.
data_fifo_overflow	1	ROL	Overflow in the data cell FIFO in external memory.

Table 173 - RX_SAR Status Register

Address: 702h Label: status Reset Value: 0000h			
Label	Bit Position	Type	Description
error_fifo_overflow	2	ROL	Overflow in the error report structure FIFO in external memory.
reserved	15:3	ROL	Reserved. Always read as "0000_0000_0000_0"

Table 173 - RX_SAR Status Register (continued)

Address: 704h Label: status_ie Reset Value: 0000h			
Label	Bit Position	Type	Description
rxsarpip_overflow_ie	0	IE	When '1' and the corresponding status bit is '1', an interrupt will be generated.
data_fifo_overflow_ie	1	IE	When '1' and the corresponding status bit is '1', an interrupt will be generated.
error_fifo_overflow_ie	2	IE	When '1' and the corresponding status bit is '1', an interrupt will be generated.
reserved	15:3	IE	Reserved. Always read as "0000_0000_0000_0"

Table 174 - RX_SAR Interrupt Enable Register

Address: 00708h Label: data_cell_read Reset Value: 0000h			
Label	Bit Position	Type	Description
data_read_pnt	13:0	RW	The CPU's read pointer to the AAL0 cell FIFO.
reserved	15:14	RW	Reserved. Must always be "00"

Table 175 - RX_SAR Data Read Pointer Register

Address: 70Ah Label: data_cell_write Reset Value: 0000h			
Label	Bit Position	Type	Description
data_write_pnt	13:0	RO	The chip's write pointer to the AAL0 cell FIFO.
reserved	15:14	RO	Reserved. Always read as "00"

Table 176 - RX_SAR Data Write Pointer Register

Address: 70Ch Label: data_cell_add Reset Value: 0000h			
Label	Bit Position	Type	Description
data_add	13:0	RW	Bits 19:6 of the address of the FIFO in external memory
reserved	15:14	RW	Reserved. Must always be "00"

Table 177 - RX_SAR Data Address Register

Address: 70Eh Label: data_cell_size Reset Value: 0000h			
Label	Bit Position	Type	Description
data_size	13:0	RW	Size of data cell FIFO in 1 cell increments. All zeros = 16k cells.
reserved	15:14	RW	Reserved. Must always be "00"

Table 178 - RX_SAR Data Cell Size Register

Address: 710h Label: error_struct_read Reset Value: 0000h			
Label	Bit Position	Type	Description
error_read_pnt	15:0	RW	The CPU's read pointer to the error report structure FIFO.

Table 179 - Error Structure Read Register

Address: 712h Label: error_struct_write Reset Value: 0000h			
Label	Bit Position	Type	Description
error_write_pnt	15:0	RO	The chip's write pointer to the error report structure FIFO.

Table 180 - Error Structure Write Register

Address: 714h Label: error_struct_add_high Reset Value: 0000h			
Label	Bit Position	Type	Description
error_add[16]	0	RW	Bits 19:3 of the address of the error FIFO in external memory
reserved	15:1	RW	Reserved. Must always be "0000_0000_0000_000"

Table 181 - Error Structure Address High Register

Address: 716h Label: error_struct_add_low Reset Value: 0000h			
Label	Bit Position	Type	Description
error_add[15:0]	15:0	RW	Bits 19:3 of the address of the error FIFO in external memory

Table 182 - Error Structure Address Low Register

Address: 718h Label: error_struct_size Reset Value: 0000h			
Label	Bit Position	Type	Description
error_size	15:0	RW	Size of the error structure FIFO (in number of error structures, 8-bytes each).

Table 183 - Error Structure Size Register

Address: 720h Label: aal0_timeout_high Reset Value: 0000h			
Label	Bit Position	Type	Description
aal0_timeout_period[19:16]	3:0	RW	Time, in us, that an AAL0 cell can wait in the FIFO before an alarm is generated.
reserved	15:4	RW	Reserved. Must always be "0000_0000_0000"

Table 184 - AAL0 Timeout High Register

Address: 722h Label: aal0_timeout_low Reset Value: 0000h			
Label	Bit Position	Type	Description
aal0_timeout_period[15:0]	15:0	RW	Time, in us, that an AAL0 cell can wait in the FIFO before an alarm is generated.

Table 185 - AAL0 Timeout Low Register

Address: 724h Label: error_timeout_high Reset Value: 0000h			
Label	Bit Position	Type	Description
error_timeout_period[19:16]	3:0	RW	Time, in us, that an error structure can wait in the FIFO before an alarm is generated.
reserved	15:4	RW	Reserved. Must always be "0000_0000_0000"

Table 186 - Error Timeout High Register

Address: 726h Label: error_timeout_low Reset Value: 0000h			
Label	Bit Position	Type	Description
error_timeout_period[15:0]	15:0	RW	Time, in us, that an error structure can wait in the FIFO before an alarm is generated.

Table 187 - Error Timeout Low Register

Address: 730h Label: treated_pulses Reset Value: 0000h			
Label	Bit Position	Type	Description
aal0_treated_pulse	0	PUL	Written to '1' to indicate that AAL0 cell FIFO has been treated. Another alarm will not be generated until the above timeout has elapsed.
error_treated_pulse	1	PUL	Written to '1' to indicate that error structure FIFO has been treated. Another alarm will not be generated until the above timeout has elapsed.
reserved	15:2	PUL	Reserved. Always read as "0000_0000_0000_00"

Table 188 - Treated Pulses Register

5.5.8 Clock Registers

Address: 800h Label: control Reset Value: 0000h			
Label	Bit Position	Type	Description
reserved	14:0	RO	Reserved. Always Read as "0000_0000_0000_00"
test_status	15	TS	When '1', all the status bits in the register will be set.

Table 189 - Clock Control Register

Address: 802h Label: status Reset Value: 0000h			
Label	Bit Position	Type	Description
mclk_count_alarm0	0	ROL	Indicates that bits 31:16 of the mclk_count have reached the value contained in the mclk_count_high_alarm0 field.
mclk_count_alarm1	1	ROL	Indicates that bits 31:16 of the mclk_count have reached the value contained in the mclk_count_high_alarm1 field.
mclk_count_alarm2	2	ROL	Indicates that bits 31:16 of the mclk_count have reached the value contained in the mclk_count_high_alarm2 field.
reserved	15:3	ROL	Reserved. Always read as "0000_0000_0000_0"

Table 190 - Clock Status Register

Address: 804h Label: status_ie Reset Value: 0000h			
Label	Bit Position	Type	Description
mclk_count_alarm0_ie	0	IE	When '1' and the corresponding status bit is '1', and interrupt will be generated.
mclk_count_alarm1_ie	1	IE	When '1' and the corresponding status bit is '1', and interrupt will be generated.
mclk_count_alarm2_ie	2	IE	When '1' and the corresponding status bit is '1', and interrupt will be generated.
reserved	15:3	IE	Reserved. Always read as "0000_0000_0000_0"

Table 191 - Status Interrupt Enable Register

Address: 806h Label: mclk_count_high_alm0 Reset Value: 0000h			
Label	Bit Position	Type	Description
mclk_count_high_alarm0	15:0	RW	This register in conjunction with an interrupt enable can be used as a scheduler or as a Periodic Interrupt Controller.

Table 192 - MCLK Alarm 0 Register

Address: 808h Label: mclk_count_high Reset Value: 0000h			
Label	Bit Position	Type	Description
mclk_count[31:16]	15:0	RO	Freerunning counter of mclk.

Table 193 - MCLK Counter High Register

Address: 80Ah Label: mclk_count_low Reset Value: 0000h			
Label	Bit Position	Type	Description
mclk_count[15:0]	15:0	RO	Freerunning counter of mclk.

Table 194 - MCLK Counter Low Register

Address: 80Ch Label: mclk_count_high_alm1 Reset Value: 0000h			
Label	Bit Position	Type	Description
mclk_count_high_alarm1	15:0	RW	This register in conjunction with an interrupt enable can be used as a scheduler or as a Periodic Interrupt Controller.

Table 195 - MCLK Alarm 1 Register

Address: 80Eh Label: mclk_count_high_alm2 Reset Value: 0000h			
Label	Bit Position	Type	Description
mclk_count_high_alarm2	15:0	RW	This register in conjunction with an interrupt enable can be used as a scheduler or as a Periodic Interrupt Controller.

Table 196 - MCLK Alarm 2 Register

Address: 810h Label: tx_srts_reg0 Reset Value: 0300h			
Label	Bit Position	Type	Description
tx_srts_enable	0	RW	When '1', TX SRTS values will be generated at the rate indicated by the div_p and div_q registers.
tx_srts_bus_clk_sel	2:1	RW	Selects which H.100 Bus clock will be used to generate SRTS. "0x"=ct_c8(which ever is used in slave timing) ; "10" = ct_c8_a; "11"=ct_c8_b.
reserved	7:3	RW	Reserved. Must always be "0000_0"
tx_srts_fnxi_input_select	13:8	RW	Selects which pins must be used as the fnxi to generate the TX SRTS value. See Table 28, "Source Selection," on page 89 for a full description.
reserved	15:14	RW	Reserved. Must always be "00"

Table 197 - TX_SRTS 0 Register

Address: 812h Label: tx_srts_reg1 Reset Value: 0000h			
Label	Bit Position	Type	Description
tx_srts_overflow	0	ROL	This bit will be set by hardware if the number of TX SRTS values sent by the TX SRTS generation module is greater than the number of TX SRTS values read by the TX SAR.
tx_srts_underflow	1	ROL	This bit will be set by hardware if the number of TX SRTS values sent by the TX SRTS generation module is smaller than the number of TX SRTS values read by the TX SAR.
reserved	15:2	ROL	Reserved. Always read as "0000_0000_0000_00"

Table 198 - TX_SRTS 1 Register

Address: 814h Label: tx_srts_reg2 Reset Value: 0000h			
Label	Bit Position	Type	Description
tx_srts_overflow_ie	0	IE	When '1' and the corresponding status bit is '1', and interrupt will be generated.
tx_srts_underflow_ie	1	IE	When '1' and the corresponding status bit is '1', and interrupt will be generated.
reserved	15:2	IE	Reserved. Always read as "0000_0000_0000_00"

Table 199 - TX_SRTS 2 Register

Address: 818h Label: tx_srts_reg4 Reset Value: 0001h			
Label	Bit Position	Type	Description
tx_srts_srts8m8c_div_p	15:0	RW	The 8.192 MHz clock on the H.100 bus (ct_c8) must be divided by a number K in order to match the interval of 8 SRTS carrying cells. For example, a 24 channel AAL1 structured fully filled channel would require a K of $(375 / 24) = 15.625$. K must then be converted to the values P and Q using the following equation: $K = P / Q$. No rounding errors must be made in this conversion.

Table 200 - TX_SRTS 4 Register

Address: 81Ah Label: tx_srts_reg5 Reset Value: 0001h			
Label	Bit Position	Type	Description
tx_srts_srts8m8c_div_q	15:0	RW	See Table 200, "TX_SRTS 4 Register," on page 170 for a description of tx_srts_srts8m8c_div_p.

Table 201 - TX_SRTS 5 Register

Address: 820h Label: adapsrts0_reg0 Reset Value: 0000h			
Label	Bit Position	Type	Description
adapsrts0_adaptive_enable	0	RW	When '1', the RX Adaptive block 0 is activated. Received cells on VCs tagged as clock recovery VC 'A' will generate an Adaptive point that will be written to external memory.
adapsrts0_rx_srts_enable	1	RW	When '1', the RX SRTS block 0 is activated. Received SRTS values on VCs tagged as clock recovery VC 'A' will be written to external memory. Also, local SRTS value will be generated using of the H.100 clocks.
adapsrts0_ignore_crc	2	RW	When '1', this bit forces the CRC in the AAL1 Header to be ignored. CRC Errors are reported no matter the state of this bit.
adapsrts0_ignore_parity	3	RW	When '1', this bit forces the Parity bit in the AAL1 Header to be ignored. Parity Errors are reported no matter the state of this bit.
adapsrts0_ignore_seq_num	4	RW	When '1', this bit forces the Sequence Number t in the AAL1 Header to be ignored. Sequence Number Errors are reported no matter the state of this bit.
adapsrts0_pclk_loss	5	RW	This bit can be directly routed out on a recov_X pin in order to convey the state (good / bad) of the clock generated by the adapsrts block 0.
adapsrts0_pclk_divisor_load_now	6	PUL	When this bit is written to '1', the pclk_div and pclk_frc are loaded into the digital PLL used to synthesize the pclk.
adapsrts0_pclk_divisor_reset	7	RW	When '0', the digital PLL used to synthesize pclk is put in reset state. When '1', it is not longer in reset.
reserved	15:8	RW	Reserved. Must always be "0000_0000"

Table 202 - Adaptive SRTS0 0 Register

Address: 822h Label: adapsrts0_reg1 Reset Value: 0000h			
Label	Bit Position	Type	Description
adapsrts0_aal1_crc_error	0	ROL	Set when an AAL1-byte CRC error occurs on cells used in the adapsrts0 block.
adapsrts0_aal1_bad_parity	1	ROL	Set when an AAL1-byte parity error occurs on cells used in the adapsrts0 block.
adapsrts0_single_cell_lost	2	ROL	Set when a single cell loss error occurs on cells used in the adapsrts0 block.
adapsrts0_multi_cell_lost	3	ROL	Set when a multiple cell loss error occurs on cells used in the adapsrts0 block.
adapsrts0_cell_misinserted	4	ROL	Set when a cell misinsertion error occurs on cells used in the adapsrts0 block.
adapsrts0_timeout_flag	5	RO	Set when a the interval between two cells used in the adapsrts0 block is greater than adapsrts0_time_out_period. This bit is automatically cleared by hardware when the timeout condition ceases.
adapsrts0_timeout_pulse	6	ROL	Set when a the interval between two cells used in the adapsrts0 block is greater than adapsrts0_time_out_period.
adapsrts0_rx_srts_remote_overflow	7	ROL	Set when two consecutive remote SRTS value were received, and when the second value could not be stored because the interval was too short.
adapsrts0_rx_srts_local_overflow	8	ROL	Set when two consecutive local SRTS value were received, and when the second value could not be stored because the interval was too short.
reserved	15:9	ROL	Reserved. Always read as "0000_000"

Table 203 - Adaptive SRTS0 1 Register

Address: 824h Label: adapsrts0_reg2 Reset Value: 0000h			
Label	Bit Position	Type	Description
adapsrts0_aal1_crc_error_ie	0	IE	When '1' and the corresponding status bit is '1', and interrupt will be generated.

Table 204 - Adaptive SRTS0 2 Register

Address: 824h Label: adapsrts0_reg2 Reset Value: 0000h			
Label	Bit Position	Type	Description
adapsrts0_aal1_bad_parity_ie	1	IE	When '1' and the corresponding status bit is '1', and interrupt will be generated.
adapsrts0_single_cell_lost_ie	2	IE	When '1' and the corresponding status bit is '1', and interrupt will be generated.
adapsrts0_multi_cell_lost_ie	3	IE	When '1' and the corresponding status bit is '1', and interrupt will be generated.
adapsrts0_cell_misinserted_ie	4	IE	When '1' and the corresponding status bit is '1', and interrupt will be generated.
reserved	5	RO	Reserved. Always read as "0"
adapsrts0_timeout_pulse_ie	6	IE	When '1' and the corresponding status bit is '1', and interrupt will be generated.
adapsrts0_rx_srts_remote_overflow_ie	7	IE	When '1' and the corresponding status bit is '1', and interrupt will be generated.
adapsrts0_rx_srts_local_overflow_ie	8	IE	When '1' and the corresponding status bit is '1', and interrupt will be generated.
reserved	15:9	IE	Reserved. Always read as "0000_000"

Table 204 - Adaptive SRTS0 2 Register (continued)

Address: 826h Label: adapsrts0_reg3 Reset Value: 0000h			
Label	Bit Position	Type	Description
adapsrts0_ref_input_select	5:0	RW	In adaptive mode, this field indicates which events the adapsrts0 block will consider as a timing reference. Rising edges on the recov_X pins can be used. Cell arrival events on Clock Recovery VC A or B can be used. See Table 28, "Source Selection," on page 89" for more details.
reserved	7:6	RO	Reserved. Always read as "00"
adapsrts0_rx_fnci_input_select	13:8	RW	In SRTS mode, this selects the fnci input used in the RX SRTS block. See Table 28, "Source Selection," on page 89" for more details.
reserved	15:14	RO	Reserved. Always read as "00"

Table 205 - Adaptive SRTS0 3 Register

Address: 828h Label: adapsrts0_reg4 Reset Value: 0000h			
Label	Bit Position	Type	Description
adapsrts0_time_out_period	15:0	RW	This value defines the time-out period between two cells in both adaptive and SRTS mode. Unit is 1024 mclk cycles. 0000h will disabled checking.

Table 206 - Adaptive SRTS0 4 Register

Address: 82Ah Label: adapsrts0_reg5 Reset Value: 0000h			
Label	Bit Position	Type	Description
adapsrts0_adap_pnt_elim_x	7:0	RW	In adaptive mode, this value defined how many points will be deleted vs how many points will be kept and written to external memory. It is defined as "keep 1 point out of X".
reserved	15:8	RW	Reserved. Must always be "0000_0000"

Table 207 - Adaptive SRTS0 5 Register

Address: 82Ch Label: adapsrts0_reg6 Reset Value: 0001h			
Label	Bit Position	Type	Description
adapsrts0_srts8m8c_div_p	15:0	RW	The clock generated by the digital PLL (pclk at 8KHz) must be divided by a number K in order to match the interval of 8 SRTS carrying cells. For example, a 24 channel AAL1 structured fully filled channel would require a K of $(375 / 24) = 15.625$. K must then be converted to the values P and Q using the following equation: $K = P / Q$. No rounding errors must be made in this conversion.

Table 208 - Adaptive SRTS0 6 Register

Address: 82Eh Label: adapsrts0_reg7 Reset Value: 0001h			
Label	Bit Position	Type	Description
adapsrts0_srts8m8c_div_q	15:0	RW	See adapsrts0_srts8m8c_div_p description.

Table 209 - Adaptive SRTS0 7 Register

Address: 830h Label: adapsrts0_reg8 Reset Value: 2710h			
Label	Bit Position	Type	Description
adapsrts0_pclk_div	15:0	RW	In order to generate pclk, mclk must be divided by a factor K. This factor is likely to be fractional. The integer part of K is written in the form $X / 65536$, where X is written in the adapsrts0_pclk_frc register.

Table 210 - Adaptive SRTS0 8 Register

Address: 832h Label: adapsrts0_reg9 Reset Value: 0000h			
Label	Bit Position	Type	Description
adapsrts0_pclk_frc	15:0	RW	For a description see adapsrts0_pclk_div adapsrts0_pclk_div above.

Table 211 - Adaptive SRTS0 9 Register

Address: 840h Label: adapsrts1_reg0 Reset Value: 0000h			
Label	Bit Position	Type	Description
adapsrts1_adaptive_enable	0	RW	See adapsrts0 registers 820h to 83Eh.
adapsrts1_rx_srts_enable	1	RW	
adapsrts1_ignore_crc	2	RW	
adapsrts1_ignore_parity	3	RW	

Table 212 - Adaptive SRTS1 0 Register

Address: 840h Label: adapsrts1_reg0 Reset Value: 0000h			
Label	Bit Position	Type	Description
adapsrts1_ignore_seq_num	4	RW	
adapsrts1_pclk_loss	5	RW	
adapsrts1_pclk_divisor_load_now	6	PUL	
adapsrts1_pclk_divisor_reset	7	RW	
reserved	15:8	RW	Reserved. Must always be "0000_0000"

Table 212 - Adaptive SRTS1 0 Register (continued)

Address: 842h Label: adapsrts1_reg1 Reset Value: 0000h			
Label	Bit Position	Type	Description
adapsrts1_aal1_crc_error	0	ROL	See Address: 822h, Table 203, "Adaptive SRTS0 1 Register," on page 172.
adapsrts1_aal1_bad_parity	1	ROL	
adapsrts1_single_cell_lost	2	ROL	
adapsrts1_multi_cell_lost	3	ROL	
adapsrts1_cell_misinserted	4	ROL	
adapsrts1_timeout_flag	5	RO	
adapsrts1_timeout_pulse	6	ROL	
adapsrts1_rx_srts_remote_overflow	7	ROL	
adapsrts1_rx_srts_local_overflow	8	ROL	
reserved	15:9	ROL	Reserved. Always read as "0000_000"

Table 213 - Adaptive SRTS1 1 Register

Address: 844h Label: adapsrts1_reg2 Reset Value: 0000h			
Label	Bit Position	Type	Description
adapsrts1_aal1_crc_error_ie	0	IE	
adapsrts1_aal1_bad_parity_ie	1	IE	
adapsrts1_single_cell_lost_ie	2	IE	
adapsrts1_multi_cell_lost_ie	3	IE	See "Address: 842h" on page 176.
adapsrts1_cell_misinserted_ie	4	IE	
reserved	5	RO	
adapsrts1_timeout_pulse_ie	6	IE	
adapsrts1_rx_srts_remote_overflow_ie	7	IE	
adapsrts1_rx_srts_local_overflow_ie	8	IE	
reserved	15:9	IE	Reserved. Always read as "0000_000"

Table 214 - Adaptive SRTS1 2 Register

Address: 846h Label: adapsrts1_reg3 Reset Value: 0000h			
Label	Bit Position	Type	Description
adapsrts1_ref_input_select	5:0	RW	See "Address: 826h" on page 173.
reserved	7:6	RO	
adapsrts1_rx_fnxi_input_select	13:8	RW	
reserved	15:14	RO	

Table 215 - Adaptive SRTS1 3 Register

Address: 848h Label: adapsrts1_reg4 Reset Value: 0000h			
Label	Bit Position	Type	Description
adapsrts1_time_out_period	15:0	RW	See "Address: 828h" on page 174.

Table 216 - Adaptive SRTS1 4 Register

Address: 84Ah Label: adapsrts1_reg5 Reset Value: 0001h			
Label	Bit Position	Type	Description
adapsrts1_adap_pnt_elim_x	7:0	RW	
reserved	15:8	RW	Reserved. Must always be "0000_0000"

Table 217 - Adaptive SRTS1 5 Register

Address: 84Ch Label: adapsrts1_reg6 Reset Value: 0000h			
Label	Bit Position	Type	Description
adapsrts1_srts8m8c_div_p	15:0	RW	See "Address: 82Ch" on page 174.

Table 218 - Adaptive SRTS1 6 Register

Address: 84Eh Label: adapsrts1_reg7 Reset Value: 0000h			
Label	Bit Position	Type	Description
adapsrts1_srts8m8c_div_q	15:0	RW	See "Address: 82Eh" on page 175.

Table 219 - Adaptive SRTS1 7 Register

Address: 850h Label: adapsrts1_reg8 Reset Value: 0000h			
Label	Bit Position	Type	Description
adapsrts1_pclk_div	15:0	RW	See "Address: 830h" on page 175.

Table 220 - Adaptive SRTS1 8 Register

Address: 852h Label: adapsrts1_reg9 Reset Value: 0000h			
Label	Bit Position	Type	Description
adapsrts1_pclk_frc	15:0	RW	See "Address: 832h" on page 175.

Table 221 - Adaptive SRTS1 9 Register

Address: 860h Label: pinmux_reg0 Reset Value: 0202h			
Label	Bit Position	Type	Description
pinmux_recov_b_sel	5:0	RW	This field selects the recov_b output. See "Clockrec Source Select" page for more details.
reserved	7:6	RO	Reserved. Always read as "00".
pinmux_recov_a_sel	13:8	RW	This field selects the recov_a output. See "Clockrec Source Select" page for more details.
reserved	15:14	RO	Reserved. Always read as "00".

Table 222 - Pin Mux 0 Register

Address: 862h Label: pinmux_reg1 Reset Value: 0202h			
Label	Bit Position	Type	Description
pinmux_recov_d_sel	5:0	RW	This field selects the recov_d output. See Table 28 - "Source Selection" on page 89 for more details.
reserved	7:6	RO	Reserved. Always read as "00"
pinmux_recov_c_sel	13:8	RW	This field selects the recov_c output. See Table 28 - "Source Selection" on page 89 for more details.
reserved	15:14	RO	Reserved. Always read as "00"

Table 223 - Pin Mux 1 Register

Address: 864h Label: pinmux_reg2 Reset Value: 0202h			
Label	Bit Position	Type	Description
pinmux_recov_f_sel	5:0	RW	This field selects the recov_f output. See Table 28 - "Source Selection" on page 89 for more details.
reserved	7:6	RO	Reserved. Always read as "00"
pinmux_recov_e_sel	13:8	RW	This field selects the recov_e output. See Table 28 - "Source Selection" on page 89 for more details.
reserved	15:14	RO	Reserved. Always read as "00"

Table 224 - Pin Mux 2 Register

Address: 866h Label: pinmux_reg3 Reset Value: 0202h			
Label	Bit Position	Type	Description
pinmux_recov_h_sel	5:0	RW	This field selects the recov_h output. See Table 28 - "Source Selection" on page 89 for more details.
reserved	7:6	RO	Reserved. Always read as "00"
pinmux_recov_g_sel	13:8	RW	This field selects the recov_g output. See Table 28 - "Source Selection" on page 89 for more details.
reserved	15:14	RO	Reserved. Always read as "00"

Table 225 - Pin Mux 3 Register

Address: 868h Label: pinmux_reg4 Reset Value: 0202h			
Label	Bit Position	Type	Description
pinmux_ct_netref2_sel	5:0	RW	This field selects the ct_netref2 output. See Table 28 - "Source Selection" on page 89 for more details.
reserved	7:6	RO	Reserved. Always read as "00"
pinmux_ct_netref1_sel	13:8	RW	This field selects the ct_netref1 output. See Table 28 - "Source Selection" on page 89 for more details.
reserved	15:14	RO	Reserved. Always read as "00"

Table 226 - Pin Mux 4 Register

Address: 86Ah Label: pinmux_reg5 Reset Value: 0303h			
Label	Bit Position	Type	Description
pinmux_local_netref_16m_sel	5:0	RW	This field selects the local_16m reference feed into the H.100 master circuit. See Table 28 - "Source Selection" on page 89 for more details.
reserved	7:6	RO	Reserved. Always read as "00"
reserved	13:8	RO	Reserved. Always read as "0000_00"
reserved	15:14	RO	Reserved. Always read as "00"

Table 227 - Pin Mux 5 Register

Address: 880h Label: divicl0_reg0 Reset Value: 0300h			
Label	Bit Position	Type	Description
divicl0_clk_divisor_load_now	0	PUL	When this bit is written to '1', the integer clock divisor 0's division value will be loaded into the divisor.
divicl0_clk_divisor_reset	1	RW	When this bit is '0', the integer clock divisor 0 is put in reset. Must be '1' for normal operation.
divicl0_even_duty_cycle_select	2	RW	When '1', the duty cycle modifier will be enabled and will generate a 50% duty cycle output.
divicl0_input_invert_select	3	RW	When '1', the input of the integer clock divisor will be inverted before being divided.
divicl0_output_invert_select	4	RW	When '1', the output of the integer clock divisor will be inverted before being sent out.
reserved	12:7	RW	Reserved. Must always be "0000_00"
divicl0_input_source_select	13:8	RW	This field selects the input of the integer clock divisor. See Table 28 - "Source Selection" on page 89 for more details.
reserved	15:14	RW	Reserved. Must always be "00"

Table 228 - Integer Clock Divisor0 0 Register

Address: 882h Label: diviclck0_reg1 Reset Value: 0000h			
Label	Bit Position	Type	Description
diviclck0_ext_loss_pulse	0	ROLO	This bit is set when an external signal indicates that the input of the integer clock divisor is invalid (such as a PHY alarm).
diviclck0_ext_loss_flag	1	RO	Same as diviclck0_ext_loss_pulse, but when the error condition ceases, this bit will clear itself.
diviclck0_freq_too_high_pulse	2	ROLO	This bit is set when the integer clock divisor input's frequency is off as compared to the expected frequency (received frequency is too high).
diviclck0_freq_too_high_flag	3	RO	Same as diviclck0_freq_too_high_pulse, but when the error condition ceases, this bit will clear itself.
diviclck0_freq_too_low_pulse	4	ROLO	This bit is set when the integer clock divisor input's frequency is off as compared to the expected frequency (received frequency is too low).
diviclck0_freq_too_low_flag	5	RO	Same as diviclck0_freq_too_low_pulse, but when the error condition ceases, this bit will clear itself.
reserved	15:6	RO	Reserved. Always read as "0000_0000_00"

Table 229 - Integer Clock Divisor0 1 Register

Address: 884h Label: diviclck0_reg2 Reset Value: 0000h			
Label	Bit Position	Type	Description
diviclck0_ext_loss_pulse_ie	0	IE	When '1' and the corresponding status bit is '1', and interrupt will be generated.
reserved	1	RO	Reserved. Always read as "00"
diviclck0_freq_too_high_pulse_ie	2	IE	When '1' and the corresponding status bit is '1', and interrupt will be generated.
reserved	3	RO	Reserved. Always read as "00"
diviclck0_freq_too_low_pulse_ie	4	IE	When '1' and the corresponding status bit is '1', and interrupt will be generated.
reserved	5	RO	Reserved. Always read as "00"
reserved	15:6	RO	Reserved. Always read as "0000_0000_00"

Table 230 - Integer Clock Divisor0 2 Register

Address: 886h Label: divicl0_reg3 Reset Value: 0000h			
Label	Bit Position	Type	Description
divicl0_ext_loss_pulse_genloss	0	RW	When set, the corresponding status will cause a loss to be signaled for this divicl.
divicl0_ext_loss_flag_genloss	1	RW	When set, the corresponding status will cause a loss to be signaled for this divicl.
divicl0_freq_too_high_pulse_genloss	2	RW	When set, the corresponding status will cause a loss to be signaled for this divicl.
divicl0_freq_too_high_flag_genloss	3	RW	When set, the corresponding status will cause a loss to be signaled for this divicl.
divicl0_freq_too_low_pulse_genloss	4	RW	When set, the corresponding status will cause a loss to be signaled for this divicl.
divicl0_freq_too_low_flag_genloss	5	RW	When set, the corresponding status will cause a loss to be signaled for this divicl.
reserved	15:6	RW	Reserved. Must always be "0000_0000_00"

Table 231 - Integer Clock Divisor0 3 Register

Address: 888h Label: divicl0_reg4 Reset Value: 0063h			
Label	Bit Position	Type	Description
divicl0_ext_loss_source_select	5:0	RW	Select's which external pin will signal that the input of the integer clock divisor is good or not. See Table 28 - "Source Selection" on page 89 for more details.
divicl0_ext_loss_source_polarity	6	RW	Input of the integer clock divisor is considered bad when the select ext_loss signal is active (i.e. equal to this bit). 0 = source loss active low; 1 = source loss active high.
divicl0_output_loss_polarity	7	RW	When a loss is detected, the output signal indicating this loss is activated (i.e. the value is this register is sent out). '0' = output loss active low; '1' = output loss active high.
reserved	15:8	RW	Reserved. Must always be "0000_0000"

Table 232 - Integer Clock Divisor0 4 Register

Address: 88Ah Label: divicl0_reg5 Reset Value: 0000h			
Label	Bit Position	Type	Description
divicl0_clk_div	15:0	RW	This is the denominator used to divide the input clock. It ranges from 1 to 65535.

Table 233 - Integer Clock Divisor0 5 Register

Address: 890h Label: divicl0_reg8 Reset Value: 0000h			
Label	Bit Position	Type	Description
divicl0_freqchck_div	15:0	RW	This value will be used to divide the input clock before check it against the frequency of mclk. The higher the division value, the longer to detect a frequency too high or frequency too low, but the check is more precise. 0000h disables frequency checking.

Table 234 - Integer Clock Divisor0 8 Register

Address: 892h Label: divicl0_reg9 Reset Value: 0000h			
Label	Bit Position	Type	Description
divicl0_freqchck_max_mclk_cycles	15:0	RW	This register defines the maximum number of mclk cycles between two rising edges of the input clock divided by divicl0_freqchck_div. If a second rising edge has not been detected in divicl0_freqchck_max_mclk_cycles, the divicl0_freq_too_low will be detected.

Table 235 - Integer Clock Divisor0 9 Register

Address: 894h Label: divicl0_reg10 Reset Value: 0000h			
Label	Bit Position	Type	Description
divicl0_freqchck_min_mclk_cycles	15:0	RW	This register defines the minimum number of mclk cycles between two rising edges of the input clock divided by divicl0_freqchck_div. If a second rising edge has been detected in less than divicl0_freqchck_min_mclk_cycles, the divicl0_freq_too_high will be detected.

Table 236 - Integer Clock Divisor0 10 Register

Address: 8A0h Label: divicl1_reg0 Reset Value: 0300h			
Label	Bit Position	Type	Description
divicl1_clk_divisor_load_now	0	PUL	See registers 880h to 89Eh
divicl1_clk_divisor_reset	1	RW	
divicl1_even_duty_cycle_select	2	RW	
divicl1_input_invert_select	3	RW	
divicl1_output_invert_select	4	RW	
divicl1_input_source_select	13:8	RW	
reserved	15:14	RW	Reserved. Must always be "00"

Table 237 - Integer Clock Divisor1 0 Register

Address: 8A2h Label: divicl1_reg1 Reset Value: 0000h			
Label	Bit Position	Type	Description
divicl1_ext_loss_pulse	0	ROLO	See register 882h.
divicl1_ext_loss_flag	1	RO	
divicl1_freq_too_high_pulse	2	ROLO	
divicl1_freq_too_high_flag	3	RO	

Table 238 - Integer Clock Divisor1 1 Register

Address: 8A2h Label: diviclck1_reg1 Reset Value: 0000h			
Label	Bit Position	Type	Description
diviclck1_freq_too_low_pulse	4	ROLO	
diviclck1_freq_too_low_flag	5	RO	
reserved	15:6	RO	Reserved. Always read as "0000_0000_00"

Table 238 - Integer Clock Divisor1 1 Register

Address: 8A4h Label: diviclck1_reg2 Reset Value: 0000h			
Label	Bit Position	Type	Description
diviclck1_ext_loss_pulse_ie	0	IE	See register 884h.
reserved	1	RO	
diviclck1_freq_too_high_pulse_ie	2	IE	
reserved	3	RO	
diviclck1_freq_too_low_pulse_ie	4	IE	
reserved	5	RO	
reserved	15:6	RO	Reserved. Always read as "0000_0000_00"

Table 239 - Integer Clock Divisor1 2 Register

Address: 8A6h Label: diviclck1_reg3 Reset Value: 0000h			
Label	Bit Position	Type	Description
diviclck1_ext_loss_pulse_genloss	0	RW	See register 886h.
diviclck1_ext_loss_flag_genloss	1	RW	
diviclck1_freq_too_high_pulse_genloss	2	RW	
diviclck1_freq_too_high_flag_genloss	3	RW	
diviclck1_freq_too_low_pulse_genloss	4	RW	

Table 240 - Integer Clock Divisor1 3 Register

Address: 8A6h Label: diviclck1_reg3 Reset Value: 0000h			
Label	Bit Position	Type	Description
diviclck1_freq_too_low_flag_genloss	5	RW	
reserved	15:6	RW	Reserved. Must always be "0000_0000_00"

Table 240 - Integer Clock Divisor1 3 Register (continued)

Address: 8A8h Label: diviclck1_reg4 Reset Value: 0063h			
Label	Bit Position	Type	Description
diviclck1_ext_loss_source_select	5:0	RW	See register 888h.
diviclck1_ext_loss_source_polarity	6	RW	
diviclck1_output_loss_polarity	7	RW	
reserved	15:8	RW	Reserved. Must always be "0000_0000"

Table 241 - Integer Clock Divisor1 4 Register

Address: 8AAh Label: diviclck1_reg5 Reset Value: 0000h			
Label	Bit Position	Type	Description
diviclck1_clk_div	15:0	RW	See register 88Ah.

Table 242 - Integer Clock Divisor1 5 Register

Address: 8B0h Label: diviclck1_reg8 Reset Value: 0000h			
Label	Bit Position	Type	Description
diviclck1_freqchck_div	15:0	RW	See register 890h.

Table 243 - Integer Clock Divisor1 8 Register

Address: 8B2h Label: divicl1_reg9 Reset Value: 0000h			
Label	Bit Position	Type	Description
divicl1_freqchck_max_mclk_cycles	15:0	RW	See register 892h.

Table 244 - Integer Clock Divisor1 9 Register

Address: 8B4h Label: divicl1_reg10 Reset Value: 0000h			
Label	Bit Position	Type	Description
divicl1_freqchck_min_mclk_cycles	15:0	RW	See register 894h.

Table 245 - Integer Clock Divisor1 10 Register

Address: 8C0h Label: divicl2_reg0 Reset Value: 0300h			
Label	Bit Position	Type	Description
divicl2_clk_divisor_load_now	0	PUL	See registers 880h to 89Eh
divicl2_clk_divisor_reset	1	RW	
divicl2_even_duty_cycle_select	2	RW	
divicl2_input_invert_select	3	RW	
divicl2_output_invert_select	4	RW	
divicl2_input_source_select	13:8	RW	
reserved	15:14	RW	Reserved. Must always be "00"

Table 246 - Integer Clock Divisor2 0 Register

Address: 8C2h Label: diviclck2_reg1 Reset Value: 0000h			
Label	Bit Position	Type	Description
diviclck2_ext_loss_pulse	0	ROLO	See register 8A2h.
diviclck2_ext_loss_flag	1	RO	
diviclck2_freq_too_high_pulse	2	ROLO	
diviclck2_freq_too_high_flag	3	RO	
diviclck2_freq_too_low_pulse	4	ROLO	
diviclck2_freq_too_low_flag	5	RO	
reserved	15:6	RO	Reserved. Always read as "0000_0000_00"

Table 247 - Integer Clock Divisor2 1 Register

Address: 8C4h Label: diviclck2_reg2 Reset Value: 0000h			
Label	Bit Position	Type	Description
diviclck2_ext_loss_pulse_ie	0	IE	See register 8A4h.
reserved	1	RO	
diviclck2_freq_too_high_pulse_ie	2	IE	
reserved	3	RO	
diviclck2_freq_too_low_pulse_ie	4	IE	
reserved	5	RO	
reserved	15:6	RO	Reserved. Always read as "0000_0000_00"

Table 248 - Integer Clock Divisor2 2 Register

Address: 8C6h Label: divicl2_reg3 Reset Value: 0000h			
Label	Bit Position	Type	Description
divicl2_ext_loss_pulse_genloss	0	RW	See register 8A6h.
divicl2_ext_loss_flag_genloss	1	RW	
divicl2_freq_too_high_pulse_genloss	2	RW	
divicl2_freq_too_high_flag_genloss	3	RW	
divicl2_freq_too_low_pulse_genloss	4	RW	
divicl2_freq_too_low_flag_genloss	5	RW	
reserved	15:6	RW	Reserved. Must always be "0000_0000_00"

Table 249 - Integer Clock Divisor2 3 Register

Address: 8C8h Label: divicl2_reg4 Reset Value: 0063h			
Label	Bit Position	Type	Description
divicl2_ext_loss_source_select	5:0	RW	See register 8A8h.
divicl2_ext_loss_source_polarity	6	RW	
divicl2_output_loss_polarity	7	RW	
reserved	15:8	RW	Reserved. Must always be "0000_0000"

Table 250 - Integer Clock Divisor2 4 Register

Address: 8CAh Label: divicl2_reg5 Reset Value: 0001h			
Label	Bit Position	Type	Description
divicl2_clk_div	15:0	RW	See register 8AAh.

Table 251 - Integer Clock Divisor2 5 Register

Address: 8D0h Label: divicl2_reg8 Reset Value: 0000h			
Label	Bit Position	Type	Description
divicl2_freqchck_div	15:0	RW	See register 8B0h.

Table 252 - Integer Clock Divisor2 8 Register

Address: 8D2h Label: divicl2_reg9 Reset Value: 0000h			
Label	Bit Position	Type	Description
divicl2_freqchck_max_mclk_cycles	15:0	RW	See register 8B2h.

Table 253 - Integer Clock Divisor2 9 Register

Address: 8D4h Label: divicl2_reg10 Reset Value: 0000h			
Label	Bit Position	Type	Description
divicl2_freqchck_min_mclk_cycles	15:0	RW	See register 8B4h.

Table 254 - Integer Clock Divisor2 10 Register

Address: 8E0h Label: tx_srts_debug Reset Value: 0000h			
Label	Bit Position	Type	Description
tx_srts_eight_cell_pulse_rol	0	ROL	Only used for tests.
tx_srts_fnxi_cnt	11:8	RO	Only used for tests.
reserved	15:12	RO	Reserved. Always read as "0000"

Table 255 - TX SRTS Debug Register

Address: 8E4h Label: adapsrts0_rx_srts_debug Reset Value: 0000h			
Label	Bit Position	Type	Description
adapsrts0_eight_cell_pulse_rol	0	ROL	Only used for tests.
adapsrts0_rx_srts_fnxi_cnt	11:8	RO	Only used for tests.
reserved	15:12	RO	Reserved. Always read as "0000"

Table 256 - RX SRTS Debug 0 Register

Address: 8E8h Label: adapsrts1_rx_srts_debug Reset Value: 0000h			
Label	Bit Position	Type	Description
adapsrts1_eight_cell_pulse_rol	0	ROL	Only used for tests.
adapsrts1_rx_srts_fnxi_cnt	11:8	RO	Only used for tests.
reserved	15:12	RO	Reserved. Always read as "0000"

Table 257 - RX SRTS Debug 1 Register

Address: 8ECh Label: adapsrts_aal1_err_debug Reset Value: 0000h			
Label	Bit Position	Type	Description
adapsrts0_valid_cell	0	ROL	Only used for tests.
adapsrts0_cell_lost	1	ROL	Only used for tests.
adapsrts1_valid_cell	2	ROL	Only used for tests.
adapsrts1_cell_lost	3	ROL	Only used for tests.
reserved	15:4	ROL	Reserved. Always read as "0000_0000_0000"

Table 258 - AAL1 Error Debug Register

5.5.9 Miscellaneous Registers

Address: 900h Label: control Reset Value: 0000h			
Label	Bit Position	Type	Description
test_status	15	TS	When '1', all the status bits in the register will be set.

Table 259 - Miscellaneous Control Register

Address: 902h Label: err_reg0 Reset Value: 0000h			
Label	Bit Position	Type	Description
adap_srts_remote0_mem_overflow	0	ROL	Indicates that the chip did not have time to write an adaptive point structure before the next one was generated.
adap_srts_remote1_mem_overflow	1	ROL	Indicates that the chip did not have time to write an adaptive point structure before the next one was generated.
srts_local0_mem_overflow	2	ROL	Indicates that the SRTS value buffer overflowed.
srts_local1_mem_overflow	3	ROL	Indicates that the SRTS value buffer overflowed.
cas_mem_overflow	4	ROL	Indicates that the CAS change memory overflowed.
silent_tone_error	5	ROL	New silent tones were requested before the current ones could be fetched.
reserved	15:6	ROL	Reserved. Always read as "0000_0000_00"

Table 260 - Miscellaneous Error Register

Address: 908h Label: silent_tone_reg2 Reset Value: 0000h			
Label	Bit Position	Type	Description
silent_size	15:0	RW	Size of the silent tone buffers, in bytes minus 1. 0 means 1 byte; FFFFh means 10000h bytes.

Table 261 - Silent Tone 2 Register

Address: 90Ah Label: silent_tone_reg3 Reset Value: 0000h			
Label	Bit Position	Type	Description
silent_base_add_15_0	15:0	RW	The base address of the silent tone buffers (in words).

Table 262 - Silent Tone 3 Register

Address: 90Ch Label: silent_tone_reg3 Reset Value: 0000h			
Label	Bit Position	Type	Description
silent_base_add_18_16	2:0	RW	The base address of the silent tone buffers (in words).
reserved	15:3	RW	Reserved. Must always be "0000_0000_0000_0"

Table 263 - Silent Tone 4 Register

Address: 90Eh Label: as0_srts_reg0 Reset Value: 0000h			
Label	Bit Position	Type	Description
adap_srts0_size	15:0	RW	Size of the adaptive point/SRTS value buffer minus one. 0 means 1; FFFFh means 10000h.

Table 264 - Adaptive Point/SRTS Value 0 Register

Address: 910h Label: as0_srts_reg1 Reset Value: 0000h			
Label	Bit Position	Type	Description
adap_srts0_base_add_15_0	15:0	RW	The base address of the adaptive point/SRTS value buffer (in points or SRTS values). Note that since adaptive points are 8 words, bits 18:16 of the base address are ignored.

Table 265 - Adaptive Point/SRTS Base Address Low 0 Register

Address: 912h Label: as0_srts_reg2 Reset Value: 0000h			
Label	Bit Position	Type	Description
adap_srts0_base_add_18_16	2:0	RW	The base address of the adaptive point/SRTS value buffer (in points or SRTS values). Note that since adaptive points are 8 words, bits 18:16 of the base address are ignored.
reserved	15:3	RW	Reserved. Must always be "0000_0000_0000_0"

Table 266 - Adaptive Point/SRTS Base Address High 0 Register

Address: 914h Label: as0_srts_reg3 Reset Value: 0000h			
Label	Bit Position	Type	Description
adap_srts_remote0_write_pnt	15:0	RO	The chip's write pointer to the adaptive point/SRTS value buffer.

Table 267 - Adaptive Point/SRTS Write Pointer 0 Register

Address: 916h Label: as0_srts_reg4 Reset Value: 0000h			
Label	Bit Position	Type	Description
adap_srts_remote0_read_pnt	15:0	RW	The CPU's read pointer to the adaptive point/SRTS value buffer.

Table 268 - Adaptive Point/SRTS Read Pointer 0 Register

Address: 918h Label: as0_srts_reg5 Reset Value: 0000h			
Label	Bit Position	Type	Description
srts_local0_write_pnt	15:0	RO	The chip's write pointer to the local SRTS value buffer.

Table 269 - Local SRTS Write Pointer 0 Register

Address: 91Ah Label: as0_srts_reg6 Reset Value: 0000h			
Label	Bit Position	Type	Description
srts_local0_read_pnt	15:0	RW	The CPU's read pointer to the local SRTS value buffer.

Table 270 - Local SRTS Read Pointer 0 Register

Address: 91Ch Label: as1_srts_reg0 Reset Value: 0000h			
Label	Bit Position	Type	Description
adap_srts1_size	15:0	RW	Size of the adaptive point/SRTS value buffer minus one. 0 means 1; FFFFh means 10000h.

Table 271 - Adaptive Point/SRTS Value 1 Register

Address: 91Eh Label: as1_srts_reg1 Reset Value: 0000h			
Label	Bit Position	Type	Description
adap_srts1_base_add_15_0	15:0	RW	The base address of the adaptive point/SRTS value buffer (in points or SRTS values). Note that since adaptive points are 8 words, bits 18:16 of the base address are ignored.

Table 272 - Adaptive Point/SRTS Base Address Low 1 Register

Address: 920h Label: as1_srts_reg2 Reset Value: 0000h			
Label	Bit Position	Type	Description
adap_srts1_base_add_18_16	2:0	RW	The base address of the adaptive point/SRTS value buffer (in points or SRTS values). Note that since adaptive points are 8 words, bits 18:16 of the base address are ignored.
reserved	15:3	RW	Reserved. Must always be "0000_0000_0000_0"

Table 273 - Adaptive Point/SRTS Base Address High 1 Register

Address: 922h Label: as1_srts_reg3 Reset Value: 0000h			
Label	Bit Position	Type	Description
adap_srts_remote1_write_pnt	15:0	RO	The chip's write pointer to the adaptive point/SRTS value buffer.

Table 274 - Adaptive Point/SRTS Write Pointer 1 Register

Address: 924h Label: as1_srts_reg4 Reset Value: 0000h			
Label	Bit Position	Type	Description
adap_srts_remote1_read_pnt	15:0	RW	The CPU's read pointer to the adaptive point/SRTS value buffer.

Table 275 - Adaptive Point/SRTS Read Pointer 1 Register

Address: 926h Label: as1_srts_reg5 Reset Value: 0000h			
Label	Bit Position	Type	Description
srts_local1_write_pnt	15:0	RO	The chip's write pointer to the local SRTS value buffer.

Table 276 - Local SRTS Write Pointer 1 Register

Address: 928h Label: as1_srts_reg6 Reset Value: 0000h			
Label	Bit Position	Type	Description
srts_local1_read_pnt	15:0	RW	The CPU's read pointer to the local SRTS value buffer.

Table 277 - Local SRTS Read Pointer 1 Register

Address: 92Ah Label: cas_reg0 Reset Value: 0000h			
Label	Bit Position	Type	Description
cas_size	15:0	RW	Size of the CAS change buffer minus 1. 0 means 1; FFFFh means 10000h.

Table 278 - CAS Change Buffer Size Register

Address: 92Ch Label: cas_reg1 Reset Value: 0000h			
Label	Bit Position	Type	Description
cas_base_add_15_0	15:0	RW	Base address of the CAS change buffer.

Table 279 - CAS Change Buffer Base Address Low Register

Address: 92Eh Label: cas_reg2 Reset Value: 0000h			
Label	Bit Position	Type	Description
cas_base_add_18_16	2:0	RW	Base address of the CAS change buffer.
reserved	15:3	RW	Reserved. Must always be "0000_0000_0000_0"

Table 280 - CAS Change Buffer Base Address High Register

Address: 930h Label: cas_reg3 Reset Value: 0000h			
Label	Bit Position	Type	Description
cas_write_pnt	15:0	RO	The chip's write pointer to the CAS change buffer.

Table 281 - CAS Write Pointer Register

Address: 932h Label: cas_reg4 Reset Value: 0000h			
Label	Bit Position	Type	Description
cas_read_pnt	15:0	RW	The CPU's read pointer to the CAS change buffer.

Table 282 - CAS Read Pointer Register

Address: 944h Label: cas_timeout_hig Reset Value: 0000h			
Label	Bit Position	Type	Description
cas_timeout_period[19:16]	3:0	RW	Time, in us, that a CAS change report can wait in the FIFO before an alarm is generated.
reserved	15:4	RW	Reserved. Must always be "0000_0000_0000"

Table 283 - CAS Timeout High Register

Address: 946h Label: cas_timeout_low Reset Value: 0000h			
Label	Bit Position	Type	Description
cas_timeout_period[15:0]	15:0	RW	Time, in us, that a CAS change report can wait in the FIFO before an alarm is generated.

Table 284 - CAS Timeout Low Register

Address: 948h Label: treated pulses Reset Value: 0000h			
Label	Bit Position	Type	Description
cas_treated_pulse	0	PUL	Written to '1' to indicate that CAS change FIFO has been treated. Another alarm will not be generated until the above timeout has elapsed.
reserved	15:1	PUL	Reserved. Always read as "0000_0000_0000_000"

Table 285 - Treated Pulses Register

5.5.10 H.100 Registers

Address: A00h Label: control0 Reset Value: 0000h			
Label	Bit Position	Type	Description
h100_pll_ref_fallback	0	RW	'0' = always use selected external clk (selected by h100_pll_ext_source) to source pll's ref input. '1' = if selected clock fails, fallback on local 16.384mHz clock.
h100_pll_ext_source	1	RW	'0' = source ct_c8_a_in. '1' = source ct_c8_b_in
h100_pll_local_source	2	RW	'0' = source pll's ref input with local 16.384mHz clock, '1' = source with selected external clk (selected via h100_pll_ext_source).
h100_pll_override	3	RW	'0' = use embedded PLL to generate outgoing clocks. '1' = bypass PLL and use local 16.384 mHz clock instead.
h100_clk_loopback	4	RW	'1' = loops the ct_c8 A and B clocks and frames back into the chip. Used for tests
h100_sclk_speed	6:5	RW	"00" = 2.048 mHz. "01" = 4.096 mHz. "10" = 8.192 mHz.
h100_c8_frame_a_oe	7	RW	'0' = tri-states ct_c8_a and ct_frame_a
h100_c8_frame_b_oe	8	RW	'0' = tri-states ct_c8_b and ct_frame_b
h100_comp_oe	9	RW	'0' = tri-states all the compatibility signals
h100_pll_fb_input	11:10	RW	Selects pll's fb input: "00" = sample A, "10" = sample B, "01" = sample PLL output (div 4), "11" = reserved.
h100_frame_sync_source	12	RW	'0' = sync frame on ct_frame_a_in, '1' = sync frame on ct_frame_b_in
h100_tdmint_clk_sel	13	RW	specifies which clk to send to tdmint: '0' = use ct_c8_a. '1' = use ct_c8_b. h100_tdmint_clk_fallback can send other clk instead.
h100_tdmint_clk_fallback	14	RW	clk to tdmint if selected clk is bad: '0' = always sync on selected clk (h100_tdmint_clk_sel). '1' = if selected clk fails, switch over to backup clk.
test_status	15	TS	When '1', all the status bits in the register will be set.

Table 286 - H.100 Control 0 Register

Address: A02h Label: control1 Reset Value: 0000h			
Label	Bit Position	Type	Description
h100_force_frame_sync_local	0	RW	Only applies if h100_pll_override is '0': '0' = sync frame on selected external frame (h100_frame_sync_source), '1' = sync frame on local 16.384 MHz clk.
reserved	15:1	RW	Reserved. Must always be "0000_0000_0000_000"

Table 287 - H.100 Control 1 Register

Address: A04h Label: control2 Reset Value: 0000h			
Label	Bit Position	Type	Description
h100_min_mclk_ct_c8	3:0	RW	Minimum number of mclk cycles between ct_c8 rising edges, typically set using this equation: $((122 - 35) / \text{mclk_period_ns}) - 2$.
h100_max_mclk_ct_c8	8:4	RW	Maximum number of mclk cycles between ct_c8 rising edges, typically set using this equation: $((122 + 35) / \text{mclk_period_ns}) + 2$.
reserved	15:9	RW	Reserved. Must always be "0000_000"

Table 288 - H.100 Control 2 Register

Address: A08h Label: flags Reset Value: 0000h			
Label	Bit Position	Type	Description
h100_clk_a_bad_latched	0	RO	Indicates that the ct_c8_a period is not within +/- 35 ns of what it was supposed to be. This is a RO signal, so it means that the error is currently occurring.
h100_clk_b_bad_latched	1	RO	Indicates that the ct_c8_b period is not within +/- 35 ns of what it was supposed to be. This is a RO signal, so it means that the error is currently occurring.

Table 289 - H.100 Flags Register

Address: A08h Label: flags Reset Value: 0000h			
Label	Bit Position	Type	Description
h100_frame_a_bad_latched	2	RO	Indicates that the ct_frame_a is not occurring every 1024 ct_c8_a cycles. This is a RO signal, so it means that the error is currently occurring.
h100_frame_b_bad_latched	3	RO	Indicates that the ct_frame_b is not occurring every 1024 ct_c8_a cycles. This is a RO signal, so it means that the error is currently occurring.
reserved	15:4	RO	Reserved. Always read as "0000_0000_0000"

Table 289 - H.100 Flags Register (continued)

Address: A0Ah Label: status Reset Value: 0000h			
Label	Bit Position	Type	Description
h100_clk_a_bad_rol	0	ROLO	Indicates that the ct_c8_a period is not within +/- 35 ns of what is was supposed to be. This is a ROL signal, so it means that the error has occurred since the last time this bit was cleared.
h100_clk_b_bad_rol	1	ROLO	Indicates that the ct_c8_b period is not within +/- 35 ns of what is was supposed to be. This is a ROL signal, so it means that the error has occurred since the last time this bit was cleared.
h100_frame_a_bad_rol	2	ROLO	Indicates that the ct_frame_a is not occurring every 1024 ct_c8_a cycles. This is a ROL signal, so it means that the error has occurred since the last time this bit was cleared.
h100_frame_b_bad_rol	3	ROLO	Indicates that the ct_frame_b is not occurring every 1024 ct_c8_a cycles. This is a ROL signal, so it means that the error has occurred since the last time this bit was cleared.
reserved	15:4	ROLO	Reserved. Always read as "0000_0000_0000"

Table 290 - H.100 Status Register

Address: A0Ch Label: status_ie Reset Value: 0000h			
Label	Bit Position	Type	Description
h100_clk_a_bad_rol	0	IE	When '1' and the corresponding status bit is '1', an interrupt will be generated.
h100_clk_b_bad_rol	1	IE	When '1' and the corresponding status bit is '1', an interrupt will be generated.
h100_frame_a_bad_rol	2	IE	When '1' and the corresponding status bit is '1', an interrupt will be generated.
h100_frame_b_bad_rol	3	IE	When '1' and the corresponding status bit is '1', an interrupt will be generated.
reserved	15:4	IE	Reserved. Always read as "0000_0000_0000"

Table 291 - H.100 Interrupt Enable Register

6.0 Statistics

6.1 TDM statistics

Underrun counter: 16-bit counter that counts the number of underruns detected by TDM interface.

6.2 TX SAR statistics

Percentage of bandwidth utilisation: a register (0510h) which indicates how many mclk cycles were required to treat the last frame.

Transmitted Cell Counter: 32-bit counter that counts the number of cells transmitted on a particular VC. Each VC has its own counter in its structure.

6.3 RX SAR statistics

Error reporting structures allow software-based counters for the following errors:

- P-byte absent error
- P-byte framing error
- P-byte range error
- P-byte parity error
- Overrun error
- Underrun error
- AAL1 CRC error
- AAL1 parity error
- Single cell loss
- Multiple cell loss
- Cell misinsertion

Received Cell Counter: 32-bit counter that counts the number of cells received on a particular VC. Each VC has its own counter in its structure.

6.4 UTOPIA statistics

Transmitted Cell Counters: 32-bit counters that counts the number of cells transmitted on a particular UTOPIA port. Three counters are available for each ports.

Received Cell Counters: 32-bit counters that counts the number of cells received on a particular UTOPIA port. Each port has a dedicated counter.

Cell loss counter: 16-bit counters that counts the number of cells lost in the UTOPIA module.

7.0 Programming the fast_clk PLL

The frequency received on mclk_src pin is used by the MT90503's PLL to generate a much higher frequency (fast_clk). It is then divided down to the output mem_clk frequency.

The X, Y and Z divider can be programmed to be any value as defined in Table 292 and Table 293 on page 206. The MT90503 can support mclk_src with a frequency ranging from 30 MHz to 80 MHz. Only frequencies between 50 MHz and 53.3 MHz are not supported by the PLL. The X and Y divisor indicate what values can be programmed in the pll_conf registers 128h. Table 293, "Z Divisor Table," on page 206 indicates the range of output mem_clk that can be achieved. Note that the output mem_clk cannot be programmed to be above 80 MHz, or below 40 MHz.

The fast_clk PLL drives the output mem_clk pins. These pins provide both TTL and PECL interfaces for the output mem_clk. For both types, the output pins for the mem_clk is always driven. However, when the output pins are not being used, the register bits that control the toggling of these two pins should be disabled to reduce power consumption.

The user must configure the MT90503 to select the desired input mem_clk type, i.e., either PECL or TTL. The input mem_clk serves as the main clock (mclk) for the MT90503 and must be present for the MT90503 to function. It is absolutely necessary for the input mem_clk to be present and one of the inputs to be selected. The output mem_clk, however, are convenience for the user and do not have to be connected. These outputs eliminate the need for a second, high-speed oscillator to drive the input mem_clk.

The clock that is connected to the mem_clk inputs on the MT90503, whether it is the TTL or PECL, must be in phase with the clock connected to SSRAM used with the chip. The maximum skew allowed is ± 0.5 ns.

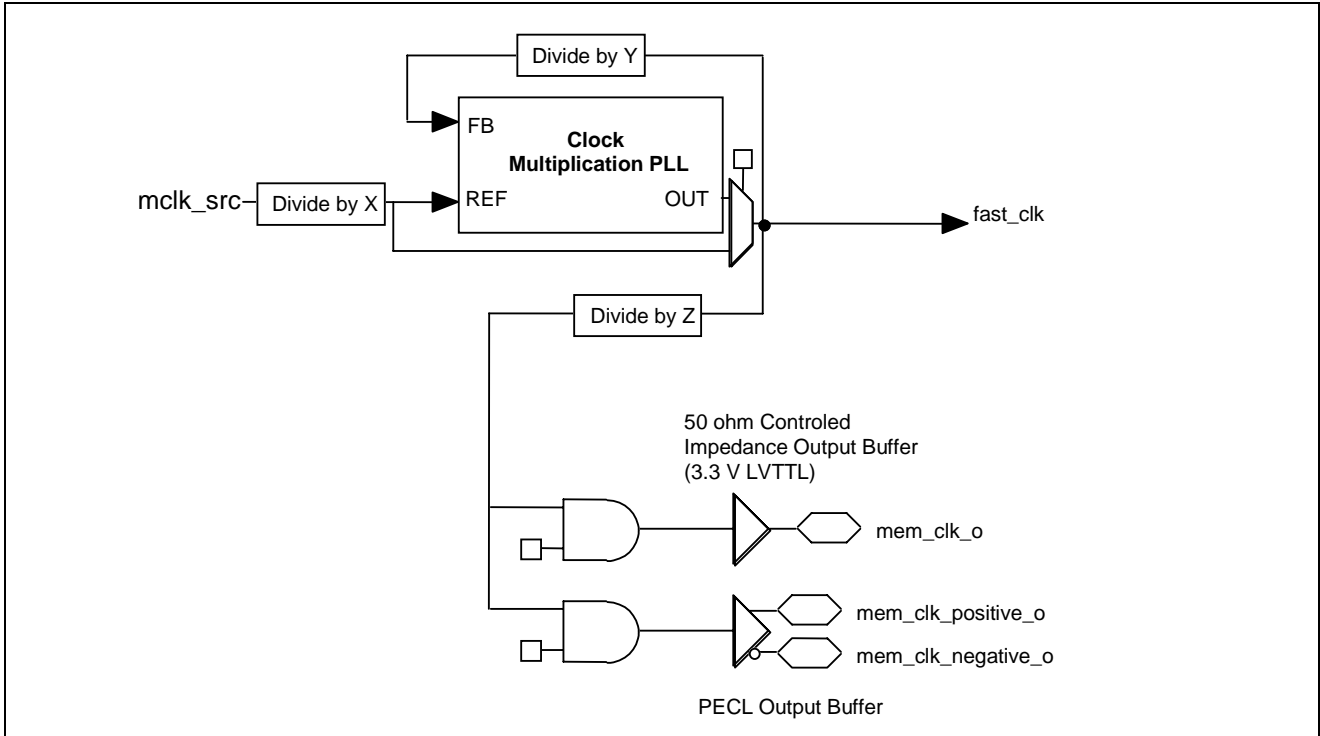

Figure 50 - mem_clk Output and fast_clk Generation Circuits

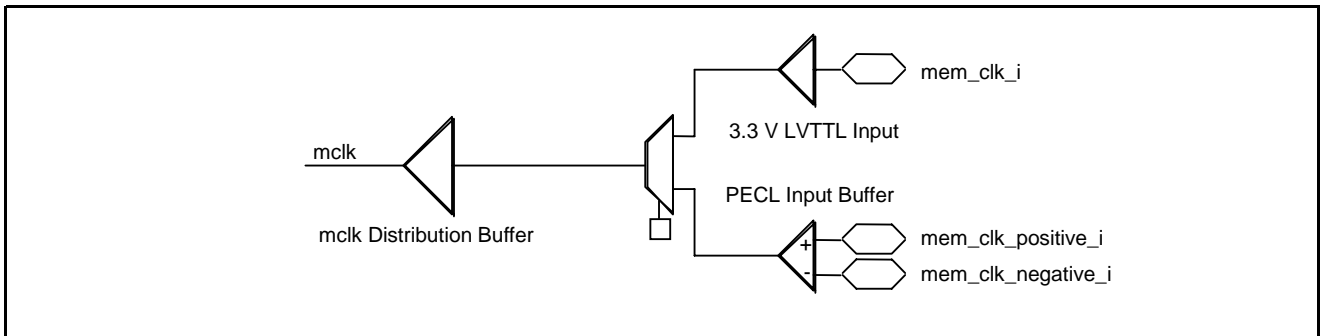

Figure 51 - mem_clk Input and mclk Generation Circuit

Div X	Div Y	mclk_src (MHz)	fast_clk (MHz)
-	-	0 to 30	-
1	6	30 to 33.33	180 to 200
1	5	33.33 to 40	166.66 to 200
1	4	40 to 50	160 to 200
-	-	50 to 53.33	-
1	3	53.33 to 66.66	160 to 200
2	5	66.66 to 80	166.66 to 200
1	2	80	160 to 200

Table 292 - Register 0128h Frequency Values

Div Z	output mem_clk
2	80
3	53.3 to 66.6
4	40 to 50

Table 293 - Z Divisor Table

8.0 Electrical Specifications

8.1 DC Characteristics

Absolute Maximum Ratings

	Parameter	Symbol	Min.	Max.	Units
1	Supply Voltage – 3.3 Volt Rail	V_{DD}	-0.3	3.9	V
2	Voltage on 3.3V Input pins	V_I	-1.0	3.6	V
3	Continuous current at digital inputs	I_I		4.0	mA
4	Continuous current at digital outputs	I_O		5.3	mA
5	Storage Temperature	T_s	-40.0	+85.0	°C

* Exceeding these figures may cause permanent damage. Functional operation under these conditions is not guaranteed. Voltage measurements are with respect to ground (V_{SS}) unless otherwise stated. Long-term exposure to absolute maximum ratings may affect device reliability, and permanent damage may occur if operate exceeding the rating. The device should be operated under recommended operating condition.

Recommended Operating Conditions

	Characteristics	Symbol	Min.	Typ.	Max.	Units	Test Conditions
1	Operating Temperature	T_{OP}	-40.0	25.0	+85.0	°C	2048 Channels with heat sink Note 1.
2	Operating Temperature	T_{OP}	-40.0	25.0	+70.0	°C	2048 Channels with no heat sink
3	Operating Temperature	T_{OP}	-40.0	25.0	+85.0	°C	1024 Channels with no heat sink
4	Supply Voltage, 3.3 Volt Rail	V_{DD}	3.0	3.3	3.6	V	
5	Input Voltage - 3.3 V inputs	V_I	$V_{SS}-0.5$	3.3	$V_{DD}+0.3$	V	

Note 1: Suitable heat sinks: Part Number 66435, Avvid Thermalloy and Part Number HS2141, Intricast, or other similar heat sinks. Typical figures are at 25°C and are for design aid only; not guaranteed and not subject to production testing. Voltage measurements are with respect to ground (V_{SS}) unless otherwise stated.

DC Characteristics

	Characteristics	Symbol	Min.	Typ.	Max.	Units	Test Conditions
1	Supply Current - 3.3 V supply	I_{DD}		720.0		mA	50.0 MHz, Nominal output loads, 1024 Channels, 16 streams active.
2	Supply Current - 3.3 V supply	I_{DDN}		970.0		mA	80.0 MHz, Nominal output loads, 2048 Channels
3	Device Power Dissipation	P_{DD1}		2.38		W	50.0 MHz, Nominal output loads, 1024 Channels, 16 streams active.
4	Device Power Dissipation	P_{DD2}		3.2		W	80.0 MHz, Nominal output loads, 2048 Channels
5	Input High Voltage	V_{IH}	2.0		VDD+0.3	V	
6	Input Low Voltage	V_{IL}	Vss-0.5		0.8	V	
7	Switching Threshold	V_{TC}		1.4	2.0	V	
8	Schmitt Trigger Positive Threshold	V_{t+}		1.7	2.0	V	
9	Schmitt Trigger Neg. Threshold	V_{t-}		0.8	1.0	V	
10	Input Leakage Current	I_I	-10.0		10.0	μ A	$V_{IN} = V_{DDx}$ or V_{SS}
11	Input Pin Capacitance	C_I		2.5		pF	
12	Output Pin Capacitance	C_O		2.0		pF	
13	Output High Impedance Leakage	I_{OZ}	-10.0	+/- 1.0	10.0	μ A	$V_O = V_{SS}$ or V_{DD}
14	Output HIGH Voltage	V_{OH}	2.4		VDD	V	$I_{OH} =$ rated current
15	Output LOW Voltage	V_{OL}		0.2	0.4	V	$I_{OL} =$ rated current
16	3.3V output HIGH current (4 mA buffer)	I_{OH}			4.0	mA	$V_{OH} = 2.4$ V
17	3.3V output LOW current (4 mA buffer)	I_{OL}			4.0	mA	$V_{OL} = 0.4$ V
18	3.3V output HIGH current (8 mA buffer)	I_{OH}			8.0	mA	$V_{OH} = 2.4$ V
19	3.3V output LOW current (8 mA buffer)	I_{OL}			8.0	mA	$V_{OL} = 0.4$ V
20	3.3V output HIGH current (12 mA buffer)	I_{OH}			12.0	mA	$V_{OH} = 2.4$ V

DC Characteristics (continued)

21	3.3V output LOW current (12 mA buffer)	I_{OL}			12.0	mA	$V_{OL} = 0.4 \text{ V}$
22	Junction-to-Ambient Thermal Resistance	θ_{J-A}		14.225		°C/W	0 cfm air flow (natural convection airflow only)

b. $T_{OP} = 0^{\circ}\text{C}$ to 70°C ; $V_{DD} = 3.3\text{V} \pm 5\%$
Voltage measurements are with respect to ground (V_{SS}) unless otherwise stated.

8.1.1 Precautions During Power Sequencing

Latch-up is not a concern during power sequencing. The only requirement for sequencing 3.3 V and 5 V supplies during power up is that the MT90503 be either held in reset until the rails are stable or have its `global_tri_state` pin held low (tristate). However, to minimise over-voltage stress during system start-up, the 3.3 V supply applied to the MT90503 should be brought to a level of at least $V_{DD} = 3.0 \text{ V}$ before a signal line is driven to a level greater than or equal to 3.3 V. This practice can be implemented either by ensuring that the 3.3 V power turns on simultaneously with or before the system 5 V supply turns on, or by ensuring that all 5 V signals are held to a logic LOW state during the time that $V_{DD} < 3.0 \text{ V}$. This condition is also met also if the MT90503 is held in reset until V_{DD} reaches 3.0 V.

Regardless of the method chosen to limit over-voltage stress during power up, exposure must be limited to no more than + 6.5 V input voltage (V_{IN}). The `global_tri_state` pin of the MT90503 can be asserted low on power-up to prevent bus contention.

8.1.2 Precautions During Power Failure

Latch-up is not a concern in power failure mode. Although extended exposure of the MT90503 to 5 V signals during 3.3 V supply power failure is not recommended, there are no restrictions as long as V_{IN} does not exceed the absolute maximum rating of 6.5 V. To minimise over-voltage stress during a 3.3 V power supply failure, the designer should either link the power supplies to prevent this condition or ensure that all 5 V signals connected to the MT90503 are held in a logic LOW state until the 5 V supply is deactivated.

8.1.3 Pull-ups

Pull-ups from the 5 V rail to 3.3 V (5 V tolerant) outputs of the MT90503 can cause reverse leakage currents into those 3.3V outputs when they are active HIGH. (No significant reverse current is present during the high impedance state.) If the application can put the MT90503 in a state where MCLK is stopped, and a large number of 3.3 V output buffers are held in a static HIGH state, current can flow from the 5 V rail to the 3.3 V rail. If this MCLK-stopped state can not be avoided, the user should determine if the total MT90503 reverse current will have a negative impact on the system 3.3 V power supply. Alternatively, the `global_tri_state` pin of the MT90503 can be asserted low to put all outputs in the high impedance state.

8.2 H.110 Diode Clamp Rail

As the MT90503 has a diode clamp to the 5 V rail, the diode clamp must be no more than 0.7 V below V_{DD} when the pin is not tristated. This can be accomplished by asserting the `global_tri_state` pin low or by keeping the MT90503 in reset until all rails are stable.

8.3 AC Characteristics

All pins are tested with 50 pf worst case loading and 15 pf best case loading unless otherwise specified.

Clock Name	Minimum Frequency	Maximum Frequency	Required For Device Operation	Minimum Duty Cycle	Maximum Duty Cycle
mem_clk_i	40 MHz	80 MHz	Yes	40%	60%
mclk_src	30 MHz	80 MHz	Yes	40%	60%
rx_a_clk	1 MHz	50 MHz	No	40%	60%
rx_b_clk	1 MHz	50 MHz	No	40%	60%
rx_c_clk	1 MHz	50 MHz	No	40%	60%
tx_a_clk	1 MHz	50 MHz	No	40%	60%
tx_b_clk	1 MHz	50 MHz	No	40%	60%
tx_c_clk	1 MHz	50 MHz	No	40%	60%
pll_clk	8.192 MHz	65.536 MHz	No	40%	60%
ct_c8_a/b	8.192 MHz	8.192 MHz	No	40%	60%
recov_a	0 MHz	80 MHz	No	40%	60%
recov_b	0 MHz	80 MHz	No	40%	60%
recov_c	0 MHz	80 MHz	No	40%	60%
recov_d	0 MHz	80 MHz	No	40%	60%
recov_e	0 MHz	80 MHz	No	40%	60%
recov_f	0 MHz	80 MHz	No	40%	60%
recov_g	0 MHz	80 MHz	No	40%	60%
recov_h	0 MHz	80 MHz	No	40%	60%

Table 294 - Clock Networks

Characteristic	Sym	Min	Typ	Max	Units	Test Conditions
mem_clk_i Frequency	t_{MF}	40.0	80.0	80.0	MHz	30ppm clock recommended for TDM PLLs
mem_clk_i Pulse Width (HIGH / LOW)	$t_{MH/L}$	5.0	6.25	7.5	ns	For 80MHz operation.

Table 295 - MCLK - Master Clock Input Parameters

9.0 Interface Timing

9.1 CPU Interface Timing

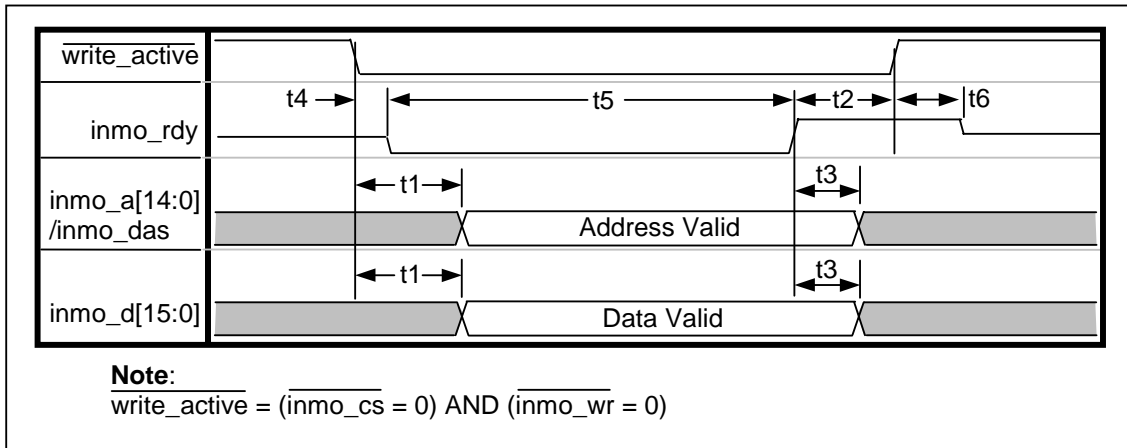

Figure 52 - Non-multiplexed CPU Write Access - Intel Mode

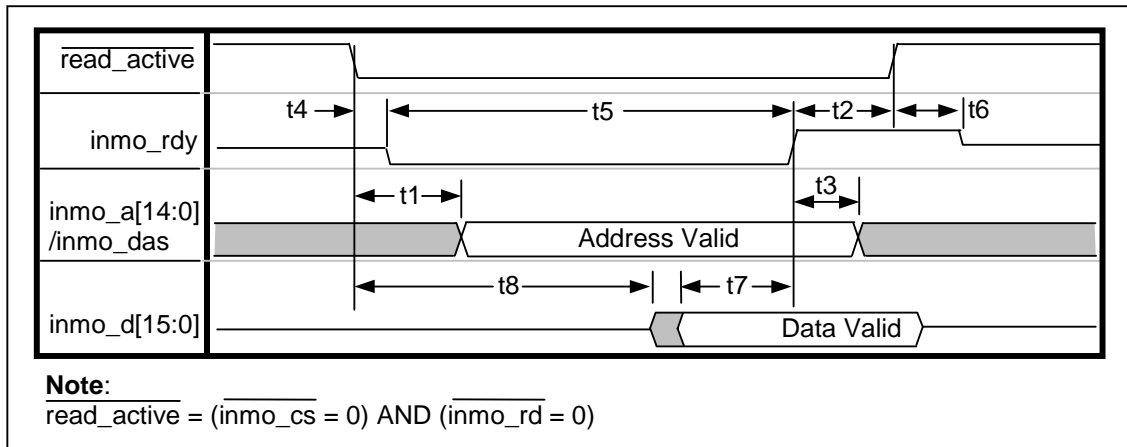
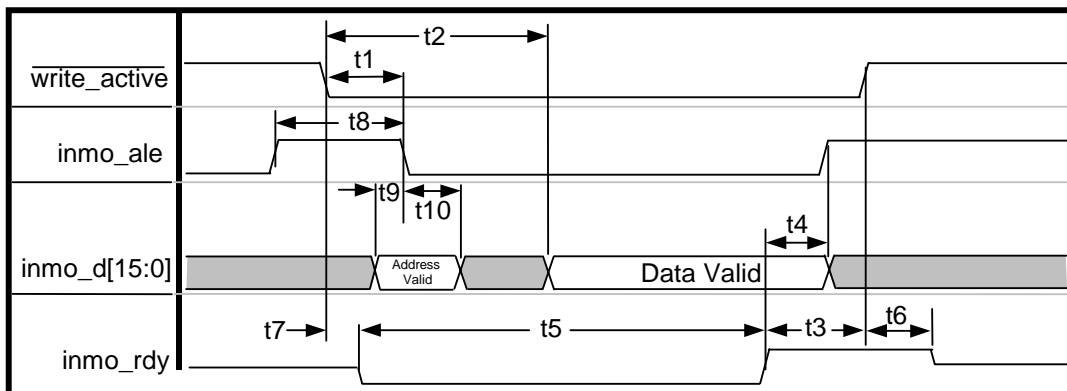

Figure 53 - Non-multiplexed CPU Read Access - Intel Mode

Symbol	Description Write Access	Min.	Typ.	Max.	Unit
t1	write_access_active falling to inmo_d/inmo_a_das/inmo_a valid			2*mclk_src - 4	ns
t2	inmo_rdy_ndtack rising to write_access_active rising	0			ns
t3	inmo_rdy_ndtack rising to inmo_d/inmo_a_das/inmo_a invalid	0			ns
t4	write_access_active falling to inmo_rdy_ndtack falling	0		12	ns
t5	Write Access Time			740	ns
t6	write_access_active rising to inmo_rdy_ndtack tri-state	0		10	ns
Symbol	Description Read Access	Min.	Typ.	Max.	Unit
t1	read_access_active falling to inmo_a_das/inmo_a valid			2*mclk_src - 4	ns
t2	inmo_rdy_ndtack rising to read_access_active rising	0			ns
t3	inmo_rdy_ndtack rising to inmo_a_das/inmo_a invalid	0			ns
t4	read_access_active falling to inmo_rdy_ndtack falling	0		12	ns
t5	Read Access Time			See Table 300	ns
t6	read_access_active rising to inmo_rdy_ndtack tri-state	0		10	ns
t7	inmo_d valid to inmo_rdy_ndtack rising	mclk_src - 4			ns
t8	read_access_active falling to inmo_d driving	3*mclk_src - 4			ns

Table 296 - Non-multiplexed CPU Interface Intel Mode



Note:
 $\overline{\text{write_active}} = (\overline{\text{inmo_cs}} = 0) \text{ AND } (\overline{\text{inmo_wr}} = 0)$

Figure 54 - Multiplexed CPU Write Access - Intel Mode

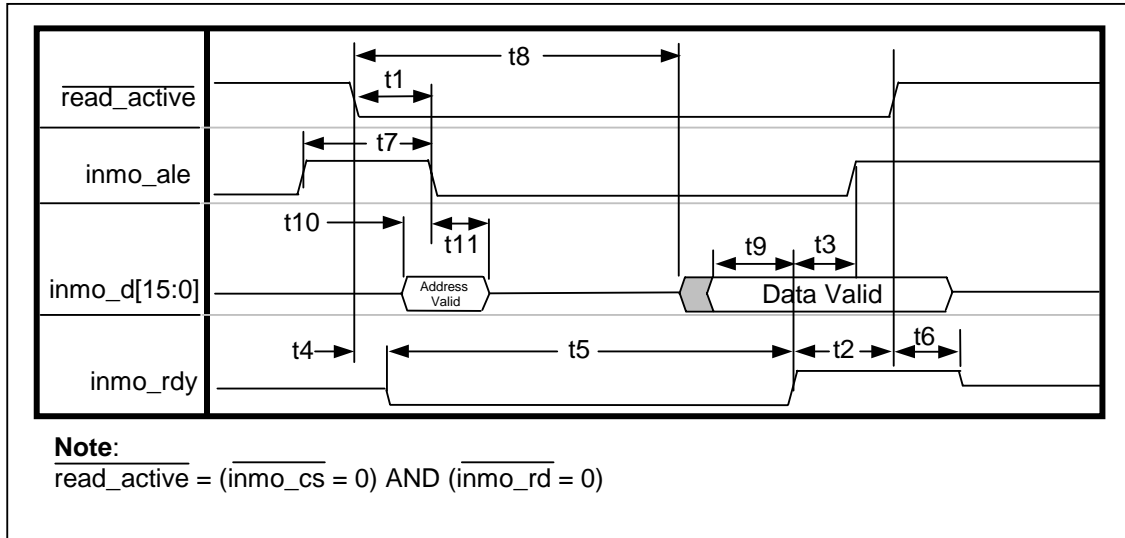

Figure 55 - Multiplexed CPU Read Access - Intel Mode

Symbol	Description Write Access	Min.	Typ.	Max.	Unit
t1	write_access_active falling to inmo_ale falling			2*mclk_src - 4	ns
t2	write_access_active falling to inmo_d valid (writes)			2*mclk_src - 4	ns
t3	inmo_rdy_ndtack rising to write_access_active rising	0			ns
t4	inmo_rdy_ndtack rising to inmo_ale rising & inmo_d invalid	0			ns
t5	Write Access Time			740	ns
t6	write_access_active rising to inmo_rdy_ndtack tri-state	0		10	ns
t7	write_access_active falling to inmo_rdy_ndtack falling	0		12	ns
t8	inmo_ale high pulse width	5			ns
t9	inmo_d valid to inmo_ale falling	5			ns
t10	inmo_ale falling to inmo_d invalid	0			ns
Symbol	Description Read Access	Min.	Typ.	Max.	Unit
t1	read_access_active falling to inmo_ale falling			2*mclk_src - 4	ns
t2	inmo_rdy_ndtack rising to read_access_active rising	0			ns
t3	inmo_rdy_ndtack rising to inmo_ale rising	0			ns
t4	read_access_active falling to inmo_rdy_ndtack falling	0		12	ns
t5	Read Access Time			See Table 300	ns

Table 297 - Multiplexed CPU Interface Intel Mode

t6	read_access_active rising to inmo_rdy_ndtack tri-state	0		10	ns
t7	inmo_ale high pulse width	5			ns
t8	read_access_active falling to inmo_d driving	$3 \cdot \text{mclk_src} - 4$			ns
t9	inmo_d valid to inmo_rdy_ndtack falling	$\text{mclk_src} - 4$			ns
t10	inmo_d valid to inmo_ale falling	5			ns
t11	inmo_ale falling to inmo_d invalid	0			ns

Table 297 - Multiplexed CPU Interface Intel Mode (continued)

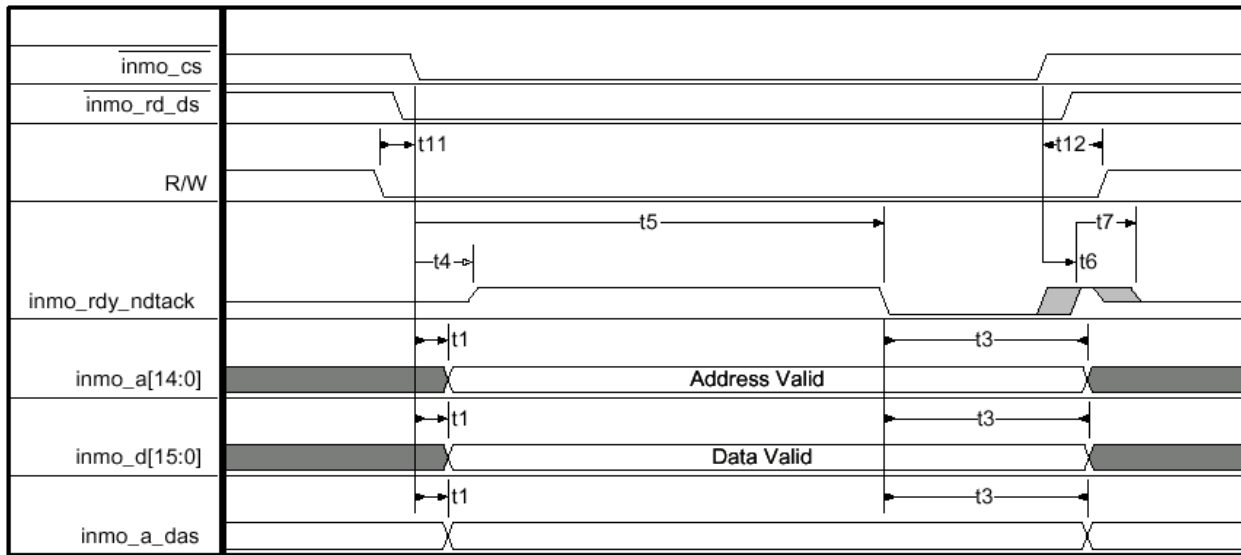

Figure 56 - Non-Multiplexed CPU Interface Write Access - Motorola Mode

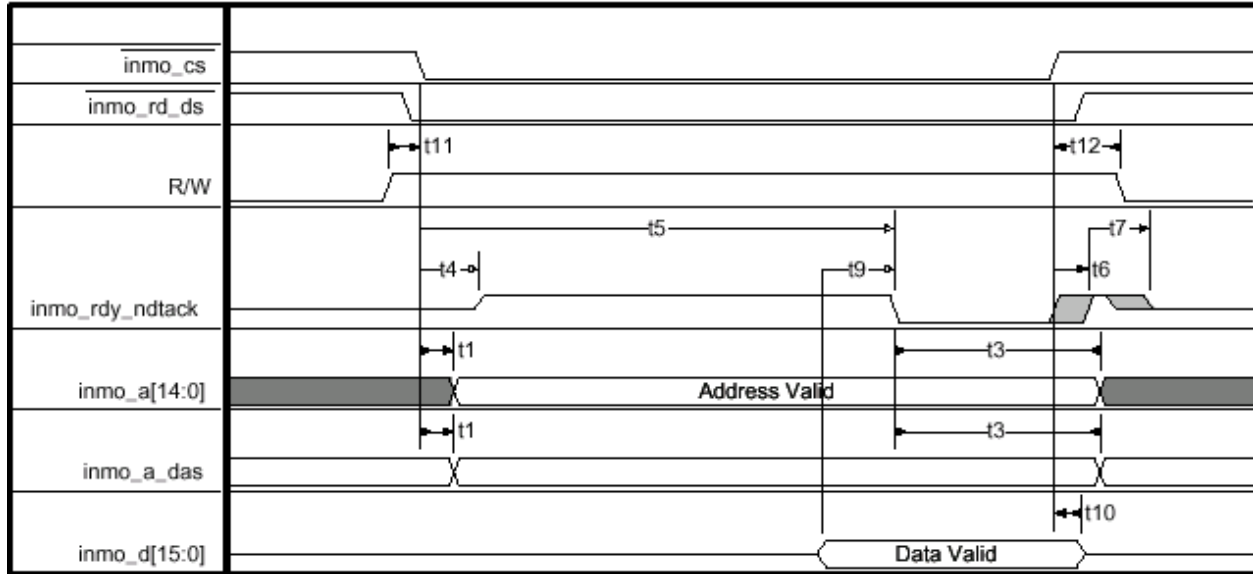

Figure 57 - Non-multiplexed CPU Interface Read Access - Motorola Mode

Symbol	Description Write Access	Min.	Typ.	Max.	Unit
t1	Address & Data Setup -- $\overline{\text{inmo_cs}}$ and $\overline{\text{inmo_rd_ds}}$ asserted to $\text{inmo_a}[14:0]$ and $\text{inmo_d}[15:0]$ and inmo_a_das valid			$2 * \text{mclk_src} - 4$	ns
t3	Address & Data Hold -- inmo_rdy_ndtack low to $\text{inmo_a}[14:0]$ and $\text{inmo_d}[15:0]$ and inmo_a_das invalid	0			ns
t4	Inmo_rdy_ndtack high -- $\overline{\text{inmo_cs}}$ and $\overline{\text{inmo_rd_ds}}$ asserted to inmo_rdy_ndtack driving one	0		12	ns
t5	Inmo_rdy_ndtack delay -- $\overline{\text{inmo_cs}}$ and $\overline{\text{inmo_rd_ds}}$ asserted to inmo_rdy_ndtack driving zero			740	ns
t6	Inmo_rdy_ndtack hold -- $\overline{\text{inmo_cs}}$ and $\overline{\text{inmo_rd_ds}}$ de-asserted to inmo_rdy_ndtack drivingb one	0		10	ns
t7	Inmo_rdy_ndtack high impedance -- inmo_rdy_ndtack driving one to inmo_rdy_ndtack high impedance	2		8	ns
t11	R/W setup -- R/W asserted to $\overline{\text{inmo_cs}}$ asserted	0			ns
t12	R/W hold -- $\overline{\text{inmo_cs}}$ deasserted to R/W deasserted	0			ns
<p>Note: t1, t4, and t5 are dependent upon the last of $\overline{\text{inmo_cs}}$ and $\overline{\text{inmo_rd_ds}}$ to be asserted. t6 is dependent on the first of $\overline{\text{inmo_cs}}$ and $\overline{\text{inmo_rd_ds}}$ to be de-asserted.</p>					
Symbol	Description Read Access	Min.	Typ.	Max.	Unit
t1	Address Setup -- $\overline{\text{inmo_cs}}$ and $\overline{\text{inmo_rd_ds}}$ asserted to $\text{inmo_a}[14:0]$ and inmo_a_das valid			$2 * \text{mclk_src} - 4$	ns

Table 298 - Non-multiplexed CPU Interface Motorola Mode

Symbol	Description Write Access	Min.	Typ.	Max.	Unit
t3	Address Hold -- $\overline{\text{inmo_rdy_ndtack}}$ low to $\overline{\text{inmo_a}}[14:0]$ and $\overline{\text{inmo_a_das}}$ invalid	0			ns
t4	$\overline{\text{Inmo_rdy_ndtack}}$ high -- $\overline{\text{inmo_cs}}$ and $\overline{\text{inmo_rd_ds}}$ asserted to $\overline{\text{inmo_rdy_ndtack}}$ driving one	0		12	ns
t5	$\overline{\text{Inmo_rdy_ndtack}}$ delay -- $\overline{\text{inmo_cs}}$ and $\overline{\text{inmo_rd_ds}}$ asserted to $\overline{\text{inmo_rdy_ndtack}}$ asserted			See Table 300	ns
t6	$\overline{\text{Inmo_rdy_ndtack}}$ hold -- $\overline{\text{inmo_cs}}$ or $\overline{\text{inmo_rd_ds}}$ de-asserted to $\overline{\text{inmo_rdy_ndtack}}$ driving one	0		10	ns
t7	$\overline{\text{Inmo_rdy_ndtack}}$ high impedance -- $\overline{\text{inmo_rdy_ndtack}}$ driving one to $\overline{\text{inmo_rdy_ndtack}}$ high-impedance	2		8	ns
t9	Data to $\overline{\text{inmo_rdy_ndtack}}$ delay -- $\overline{\text{inmo_d}}[15:0]$ valid to $\overline{\text{inmo_rdy_ndtack}}$ asserted	$\text{mclk_src} - 4$			ns
t10	Data output hold -- $\overline{\text{inmo_cs}}$ or $\overline{\text{inmo_rd_ds}}$ de-asserted to $\overline{\text{inmo_d}}[15:0]$ invalid	0		10	ns
t11	R/W setup -- R/W asserted to $\overline{\text{inmo_cs}}$ asserted	0			ns
t12	R/W hold -- $\overline{\text{inmo_cs}}$ deasserted to R/W deasserted	0			ns

Note: t1, t4, and t5 are dependent upon the last of $\overline{\text{inmo_cs}}$ and $\overline{\text{inmo_rd_ds}}$ to be asserted. t6, and t10 are dependent on the first of $\overline{\text{inmo_cs}}$ and $\overline{\text{inmo_rd_ds}}$ to be de-asserted.

Table 298 - Non-multiplexed CPU Interface Motorola Mode (continued)

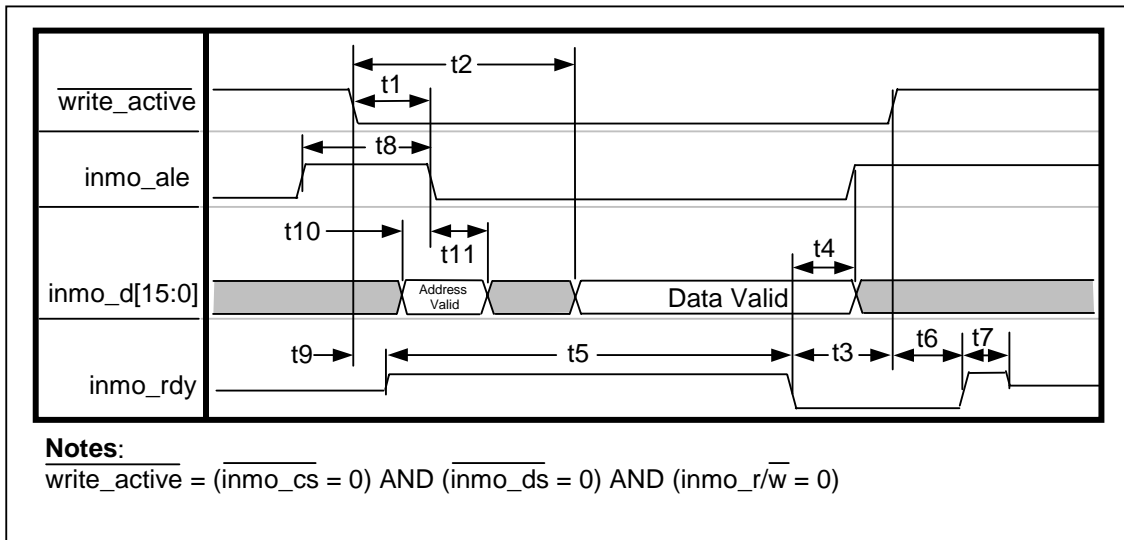

Figure 58 - Multiplexed CPU Interface Write Access - Motorola Mode

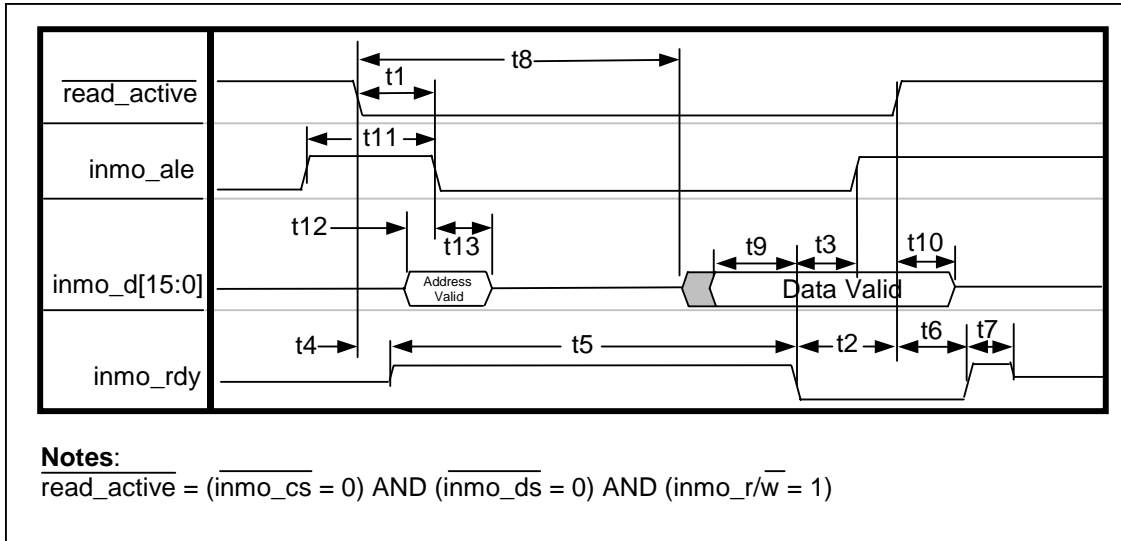

Figure 59 - Multiplexed CPU Interface Read Access - Motorola Mode

Symbol	Description Write Access	Min.	Typ.	Max.	Unit
t1	write_access_active falling to inmo_ale falling			2*mclk_src - 4	ns
t2	write_access_active falling to inmo_d valid (writes)			2*mclk_src - 4	ns
t3	inmo_rdy_ndtack falling to write_access_active rising	0			ns
t4	inmo_rdy_ndtack falling to inmo_ale rising & inmo_d invalid	0			ns
t5	Write Access Time			740	ns
t6	write_access_active rising to inmo_rdy_ndtack rising	0		10	ns
t7	inmo_rdy_ndtack rising to inmo_rdy_ndtack tri-state	2		8	ns
t8	inmo_ale high pulse width	5			ns
t9	write_access_active falling to inmo_rdy_ndtack driven high	0		12	ns
t10	inmo_d valid to inmo_ale falling	5			ns
t11	inmo_ale falling to inmo_d invalid	0			ns
Symbol	Description Read Access	Min	Typ	Max	Unit
t1	read_access_active falling to inmo_ale falling			2*mclk_src - 4	ns
t2	inmo_rdy_ndtack falling to read_access_active rising	0			ns
t3	inmo_rdy_ndtack falling to inmo_ale rising	0			ns
t4	read_access_active falling to inmo_rdy_ndtack driving high	0		12	ns

Table 299 - Multiplexed CPU Interface Motorola Mode

Symbol	Description Write Access	Min.	Typ.	Max.	Unit
t5	Read Access Time			See Table 300	ns
t6	read_access_active rising to inmo_rdy_ndtack rising	0		10	ns
t7	inmo_rdy_ndtack rising to inmo_rdy_ndtack tri-state	2		8	ns
t8	read_access_active falling to inmo_d driving	3*mclk_src - 4			ns
t9	inmo_d valid to inmo_rdy_ndtack falling	mclk_src - 4			ns
t10	read_access_active rising to inmo_d tri-state	0		10	ns
t11	inmo_ale high pulse width	5			ns
t12	inmo_d valid to inmo_ale falling	5			ns
t13	inmo_ale falling to inmo_d invalid	0			ns

Table 299 - Multiplexed CPU Interface Motorola Mode (continued)

Symbol	Description	Burst Length	Max.	Unit
t5	register and internal memory access	1 word	740	ns
t5	SSRAM	1 word	1.07	μs
t5	SSRAM	8 words	1.44	μs
t5	SSRAM	128 words	8.78	μs

Table 300 - t5 Read Access Time

9.2 UTOPIA Interface Timing

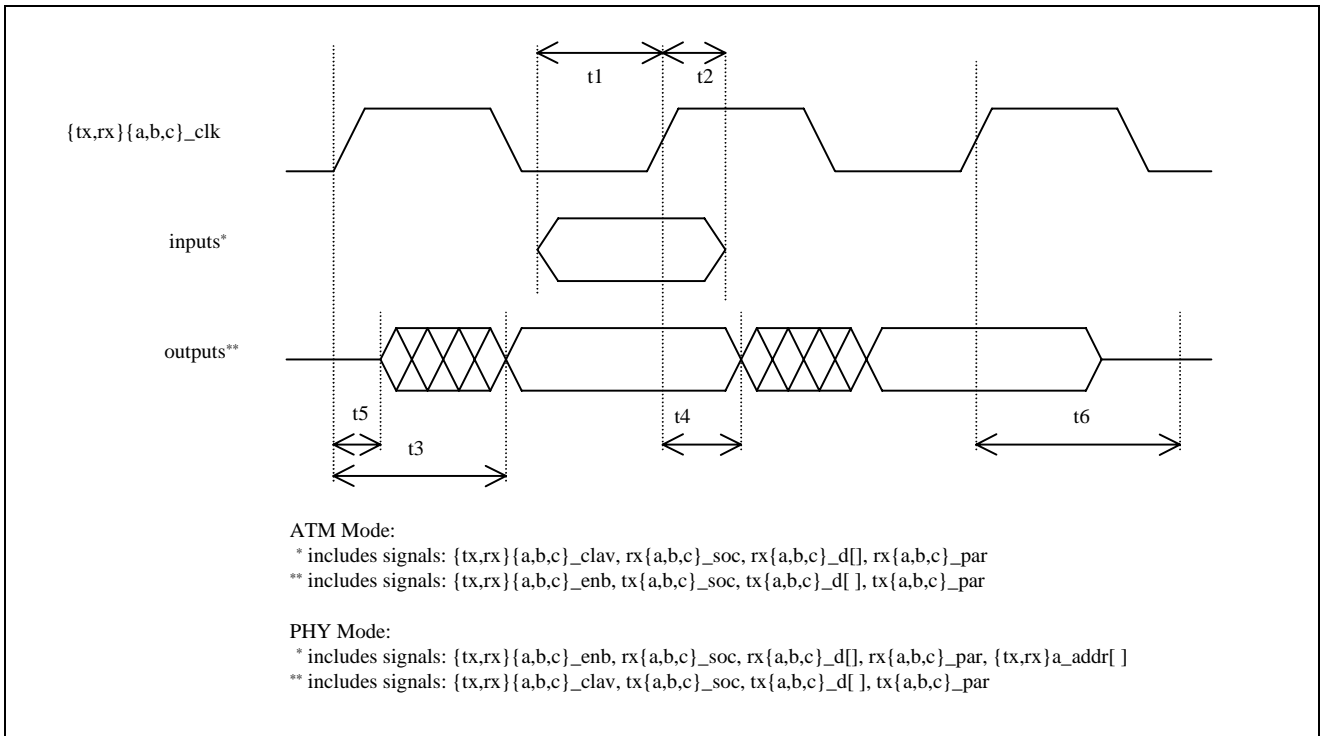

Figure 60 - UTOPIA Timing

	Characteristics	Symbol	Min.	Max.	Units
1	Input setup time	t1	4		ns
2	Input hold time	t2	1		ns
3	Clock to data valid	t3		12	ns
4	Clock to data change	t4	2		ns
5	Clock rising to signal driven	t5	1		ns
6	Clock rising to signal tri-state	t6	1	20	ns

Table 301 - UTOPIA Bus Timing

9.3 External Memory Timing

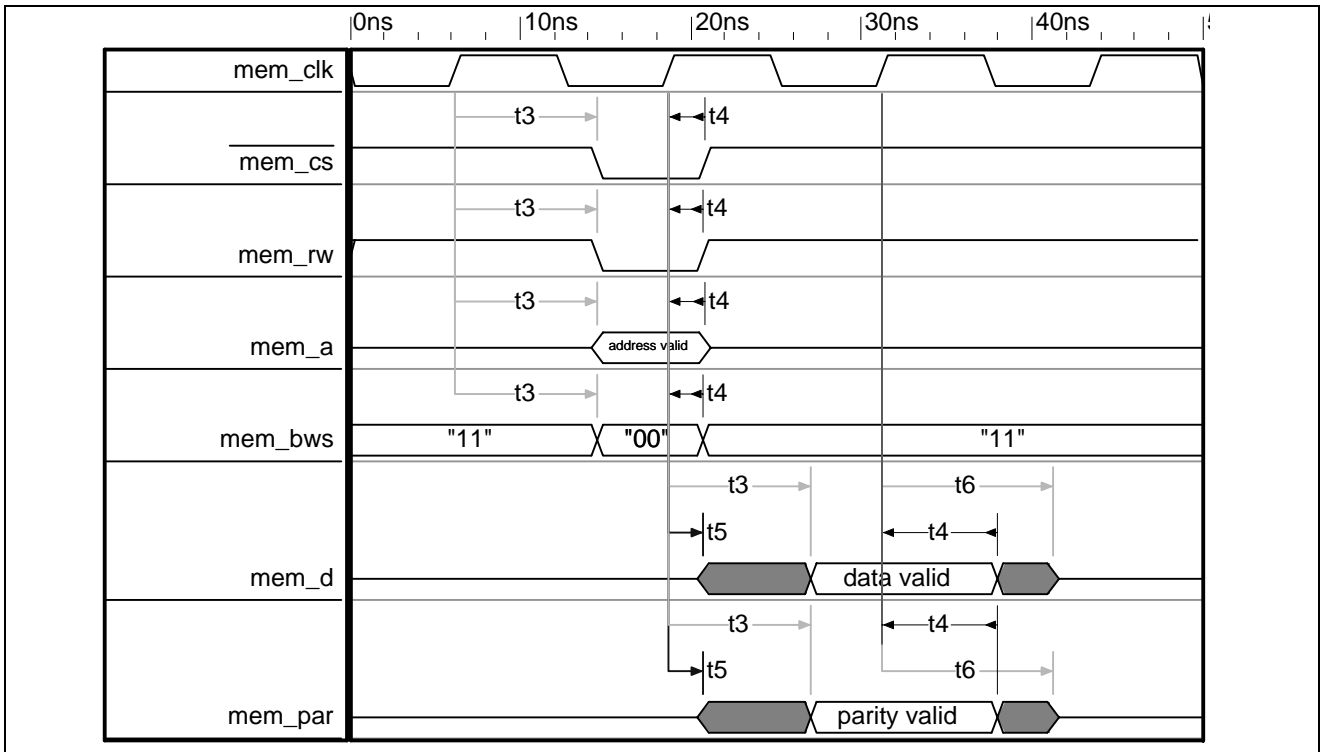

Figure 61 - Flowthrough ZBT External Memory Timing - Write Access

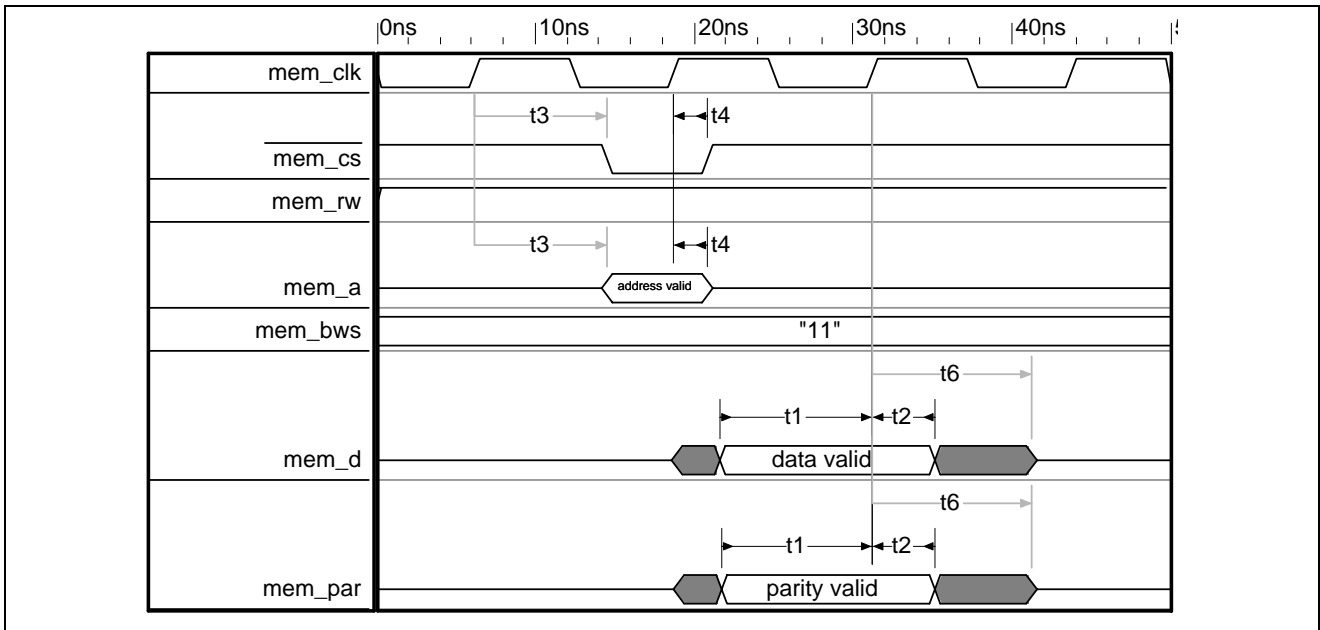

Figure 62 - Flowthrough ZBT External Memory Timing - Read Access

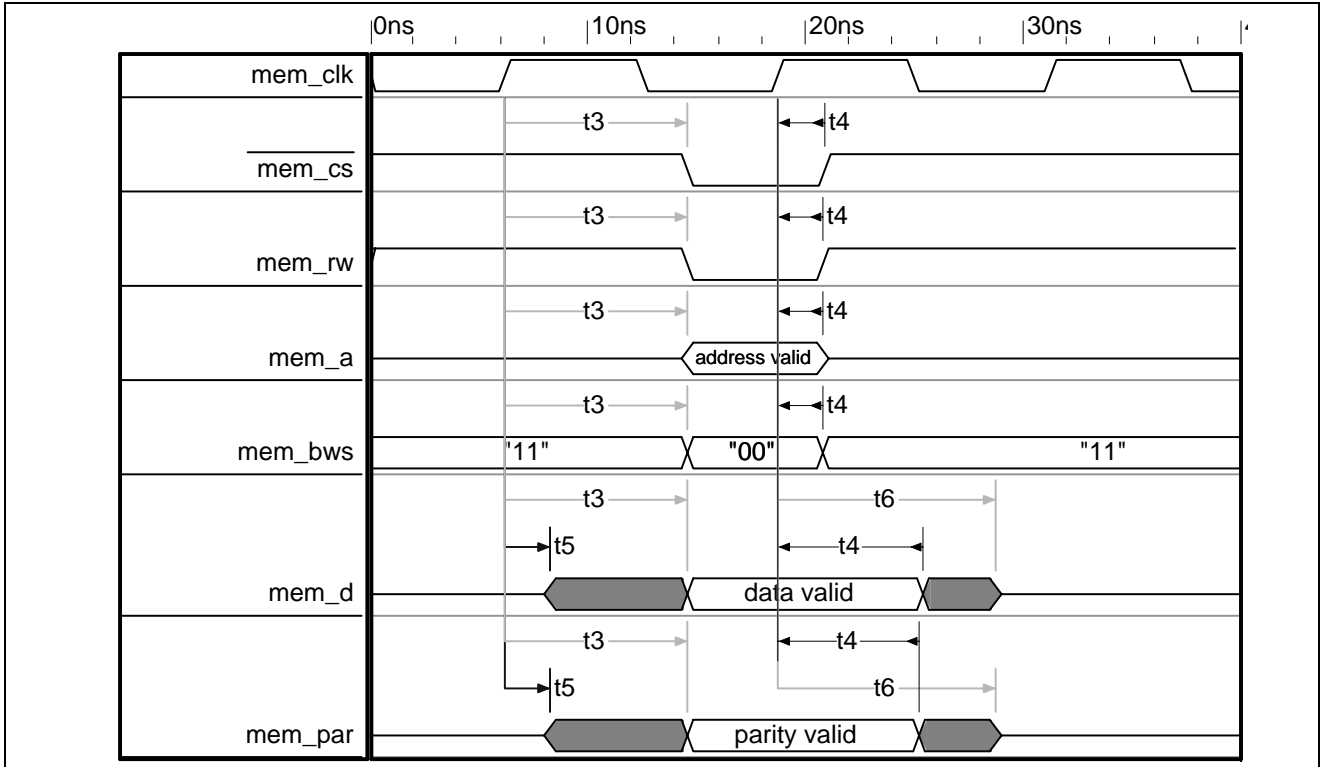

Figure 63 - Flowthrough SSRAM External Memory Timing - Write Access

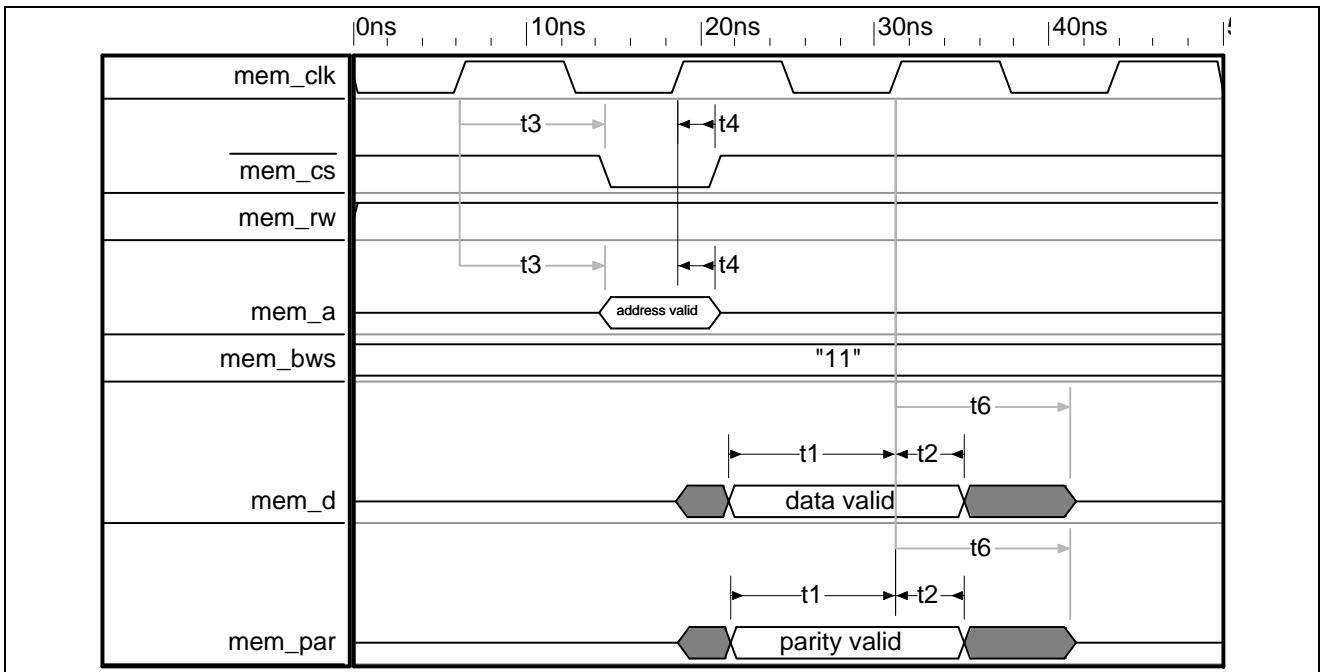

Figure 64 - Flowthrough SSRAM External Memory Timing - Read Access

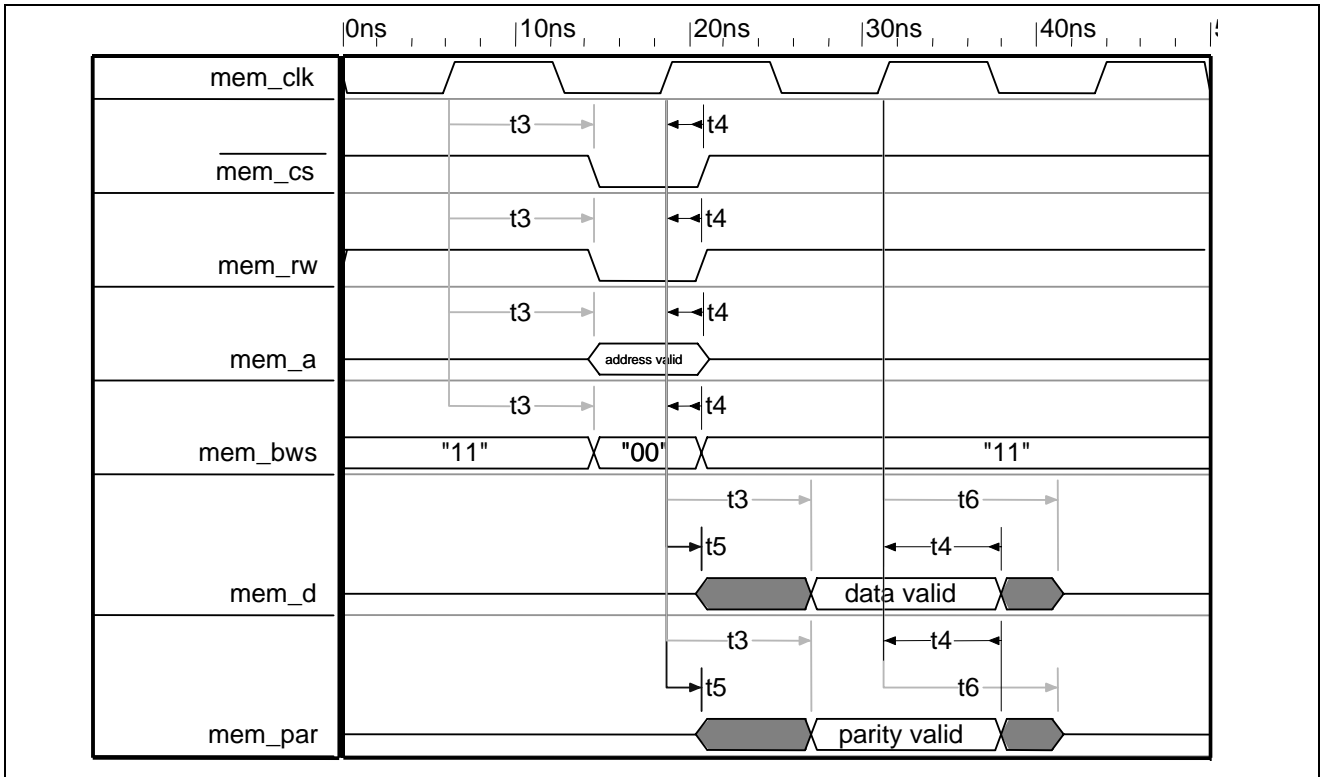

Figure 65 - Late-write External Memory Timing - Write Access

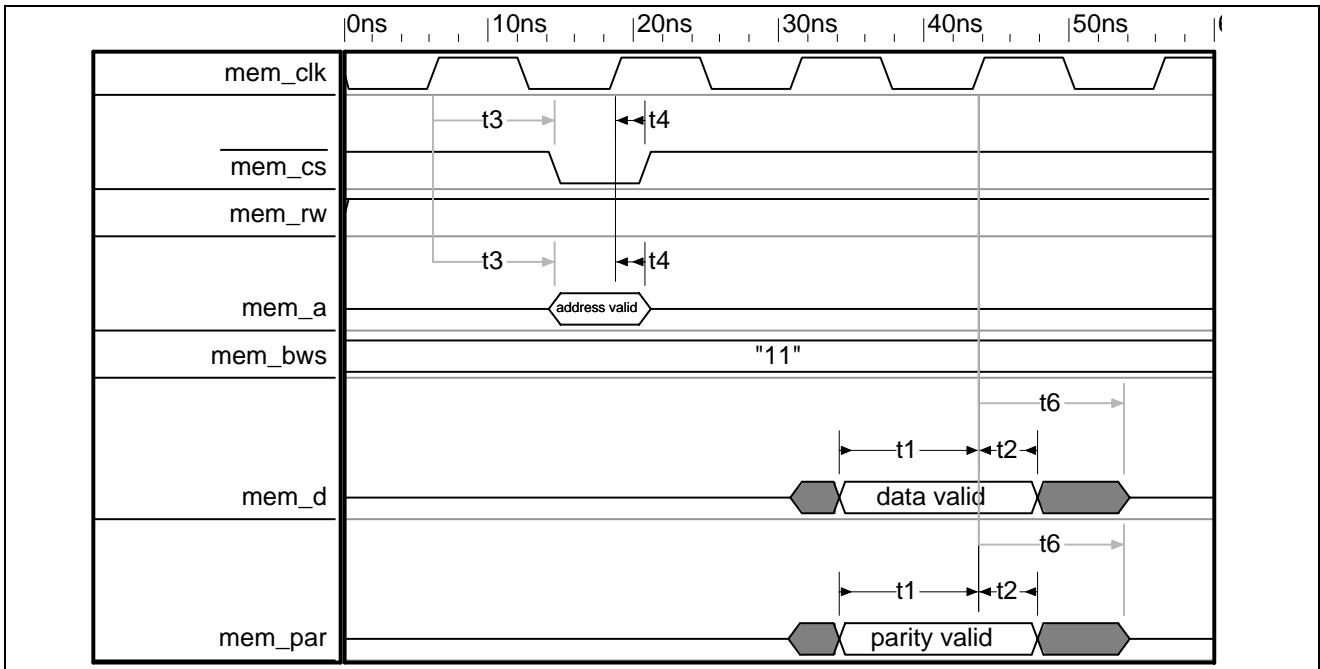

Figure 66 - Late-write External Memory Timing - Read Access

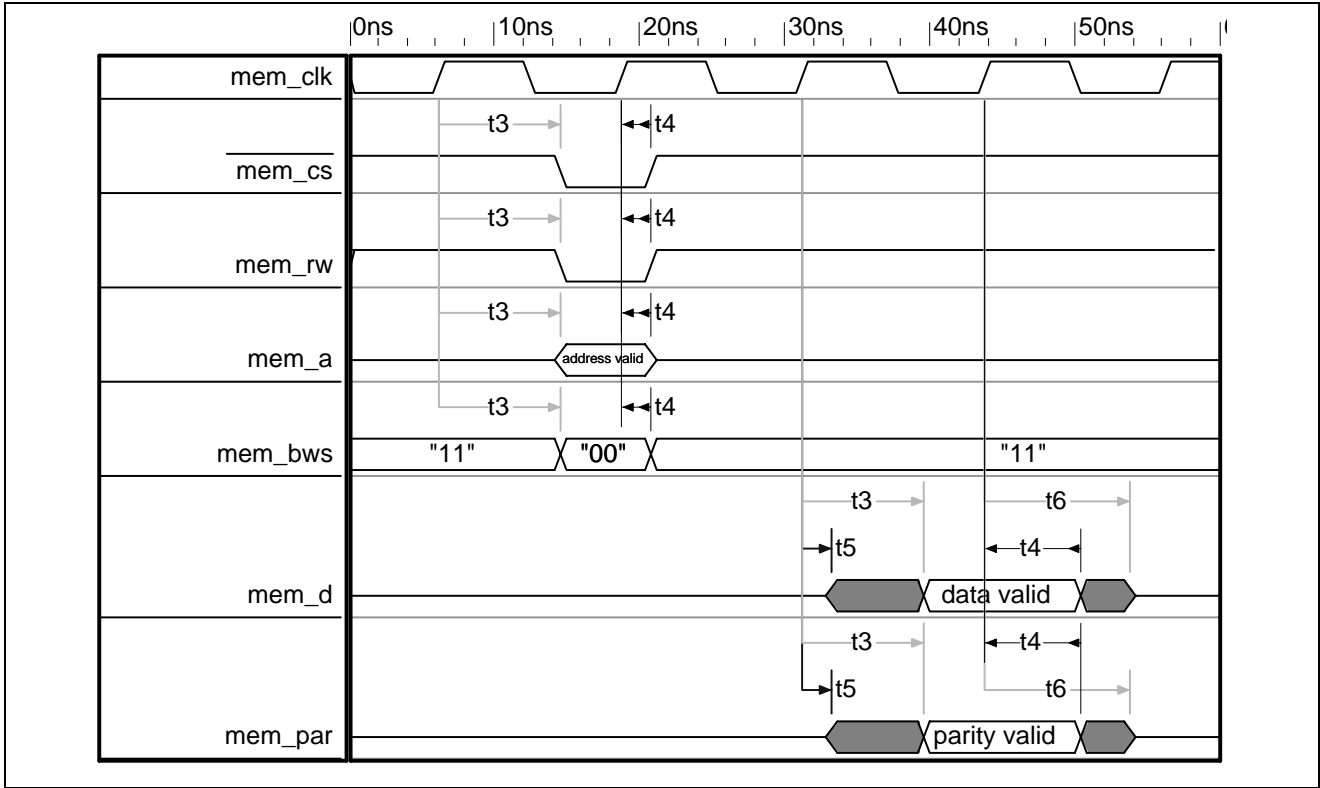

Figure 67 - Pipelined ZBT External Memory Timing - Write Access

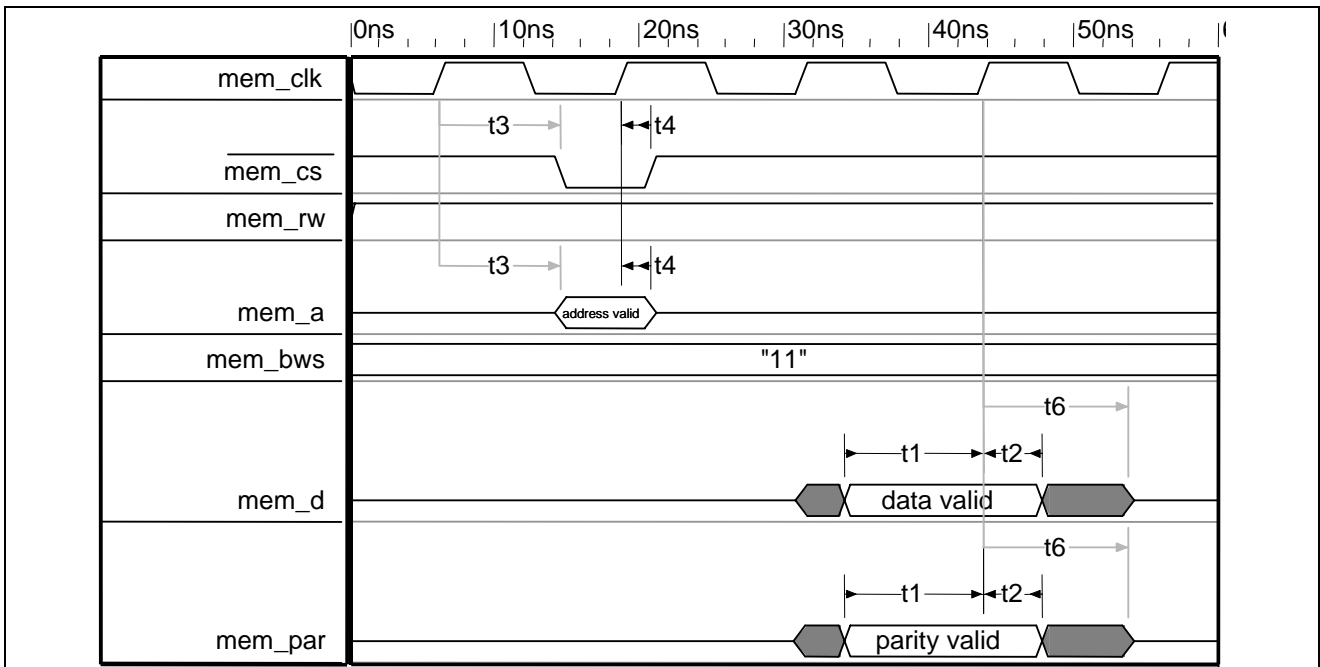

Figure 68 - Pipelined ZBT External Memory Timing - Read Access

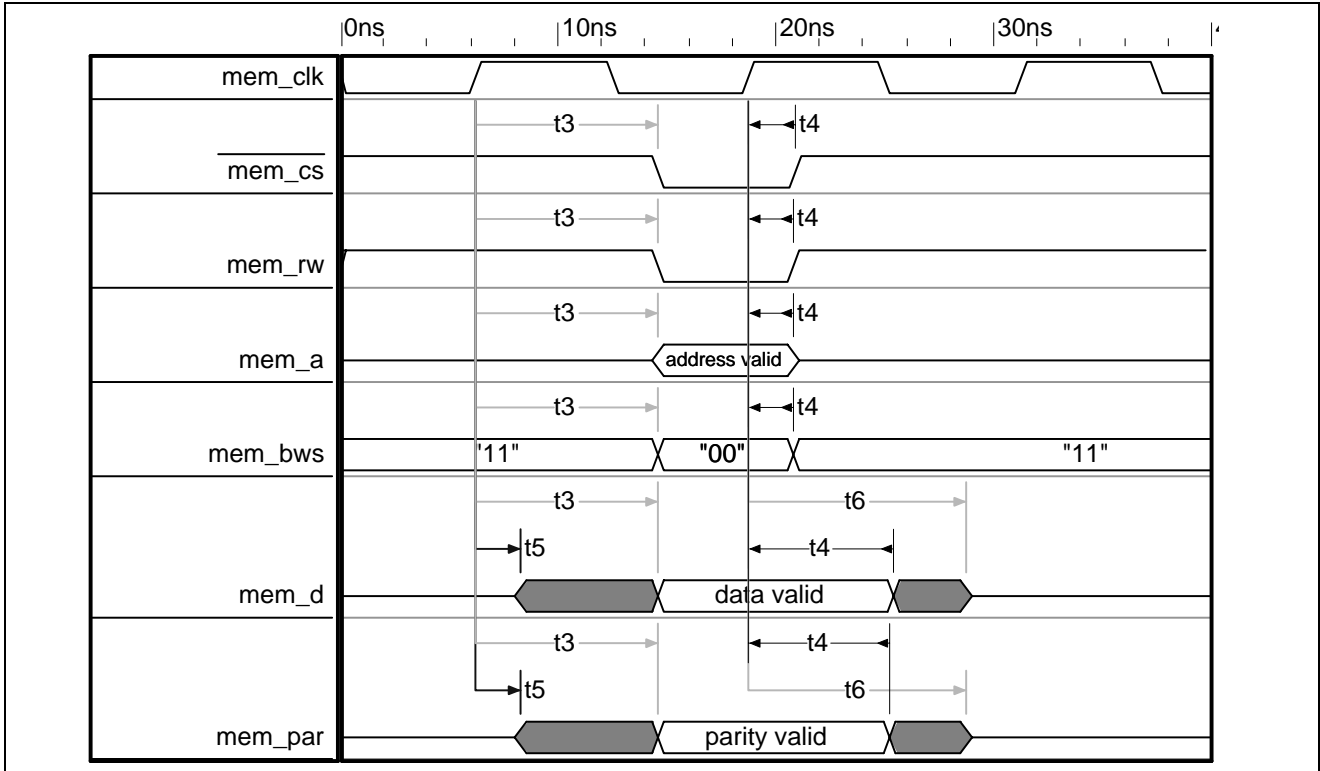

Figure 69 - Pipelined External Memory Timing - Write Access

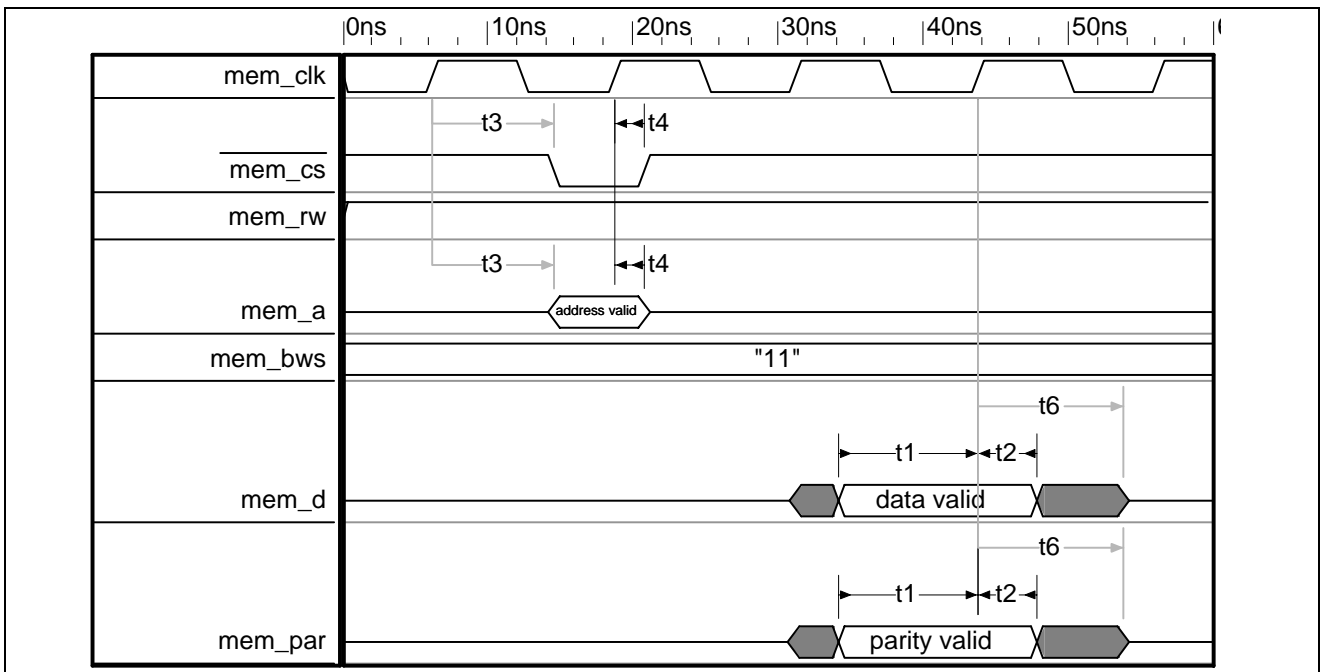

Figure 70 - Pipelined External Memory Timing - Read Access

	Characteristics	Symbol	Min.	Typ.	Max.	Units	Test Conditions
1	Input setup time	t1	2			ns	
2	Input hold time	t2	0			ns	
3	Clock to data valid	t3			8.30	ns	Primetime tested (load = 50 pf)
4	Clock to data change	t4	2			ns	Primetime tested (load = 50 pf)
3s	Clock to data valid	t3			7	ns	Spice tested with 2 memory chips
4s	Clock to data change	t4	2			ns	Spice tested with 2 memory chips
5	Clock rising to signal driven	t5	2			ns	
6	Clock rising to signal tri-state	t6			10	ns	

Table 302 - Memory Interface Timing

9.4 H.100/H.110 Interface Timing

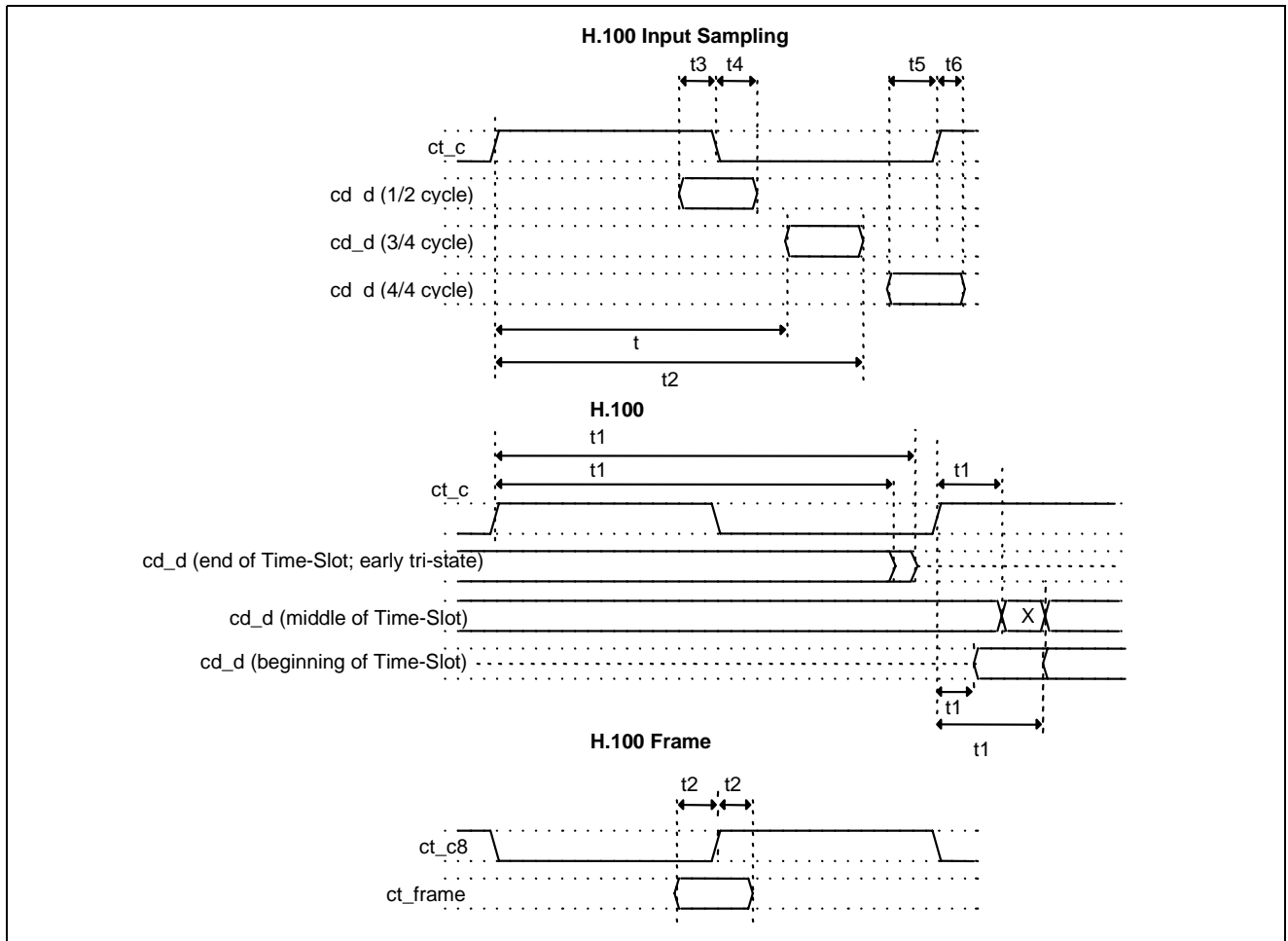

Figure 71 - H.100 Input, Output, and Frame Sampling

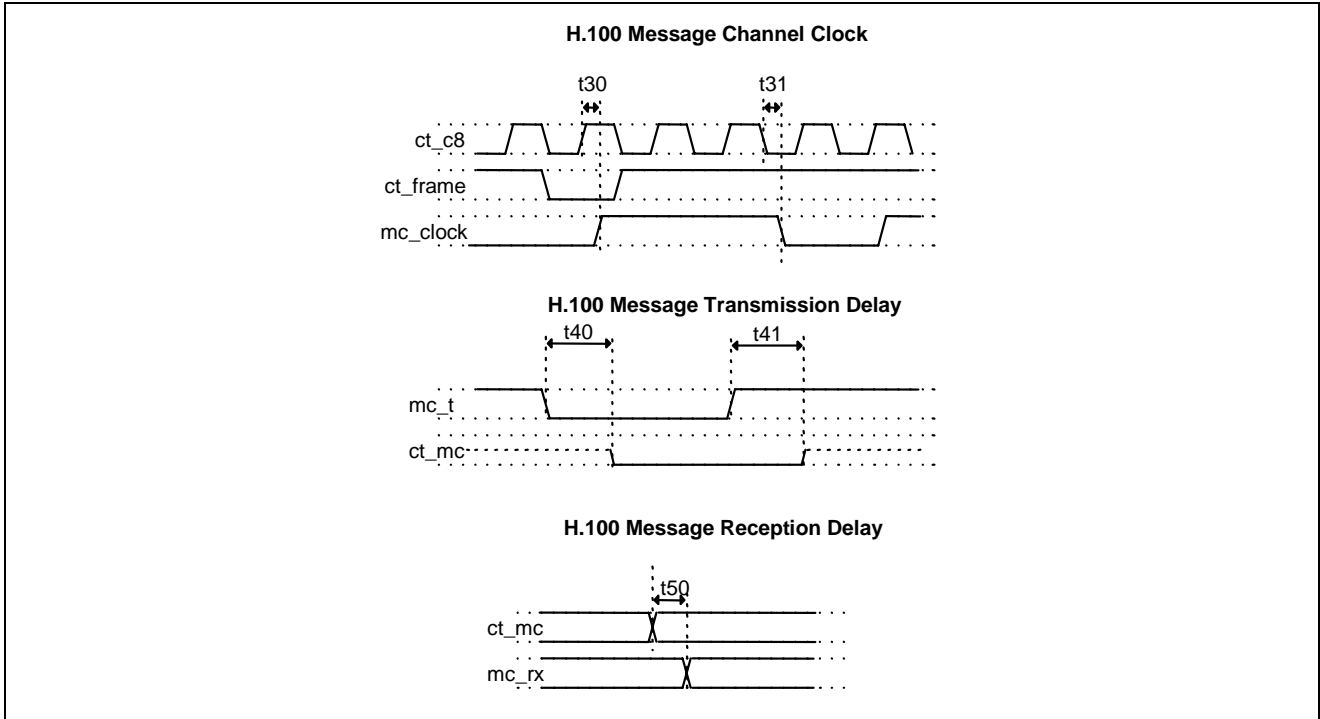

Figure 72 - H.100 Message Channel Clock, Transmission Delay, and Reception Delay

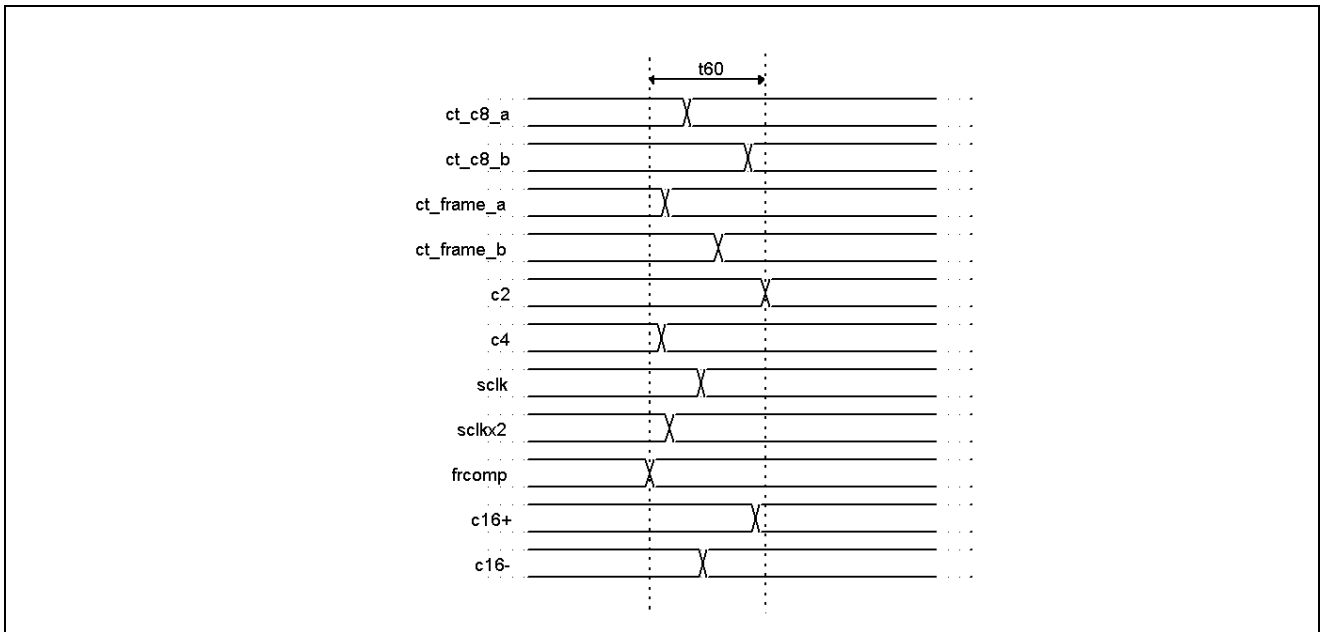

Figure 73 - H.100 Clock Skew (when chip is Master)

Symbol	Description	Min.	Typical	Max.	Unit	Notes
t1	ct_c8 rise to ct_d valid			69	ns	
t2	ct_c8 rise to ct_d invalid	102			ns	
t3	ct_d valid to ct_c8 fall	3			ns	
t4	ct_c8 fall to ct_d invalid	1			ns	
t5	ct_d valid to ct_c8 rise	5			ns	
t6	ct_c8 rise to ct_d invalid	0			ns	
t10	ct_c8 rise to ct_d tri-state			122	ns	200 pf
t11	ct_c8 rise to ct_d invalid	102			ns	200 pf
t12	ct_c8 rise to ct_d invalid	2			ns	200 pf
t13	ct_c8 rise to ct_d driven	2			ns	200 pf
t14	ct_c8 rise to ct_d valid			22	ns	200 pf
t20	ct_frame valid to ct_c8 rise	5			ns	
t21	ct_c8 rise to ct_frame invalid	5			ns	
t30	ct_c8 rise to mc_clock rise			15	ns	
t31	ct_c8 fall to mc_clock fall			15	ns	
t40	mc_tx fall to ct_mc low	3		15	ns	200 pf
t41	mc_tx rise to ct_mc tri-state	3		15	ns	200 pf
t50	ct_mc fall to mc_rx fall	3		15	ns	
t60	ct_c8_a, ct_c8_b, ct_frame_a, ct_frame_b, c2, c4, sclk, sclkx2, frcomp, c16+, c16- maximum skew when generated by the chip			5	ns	200 pf

Table 303 - H.100/H.110 Interface Timing

9.5 H.100/H.110 Clocking Signals

The MT90503's H.100/H.110 interface generates all of the following signals with the specified timing.

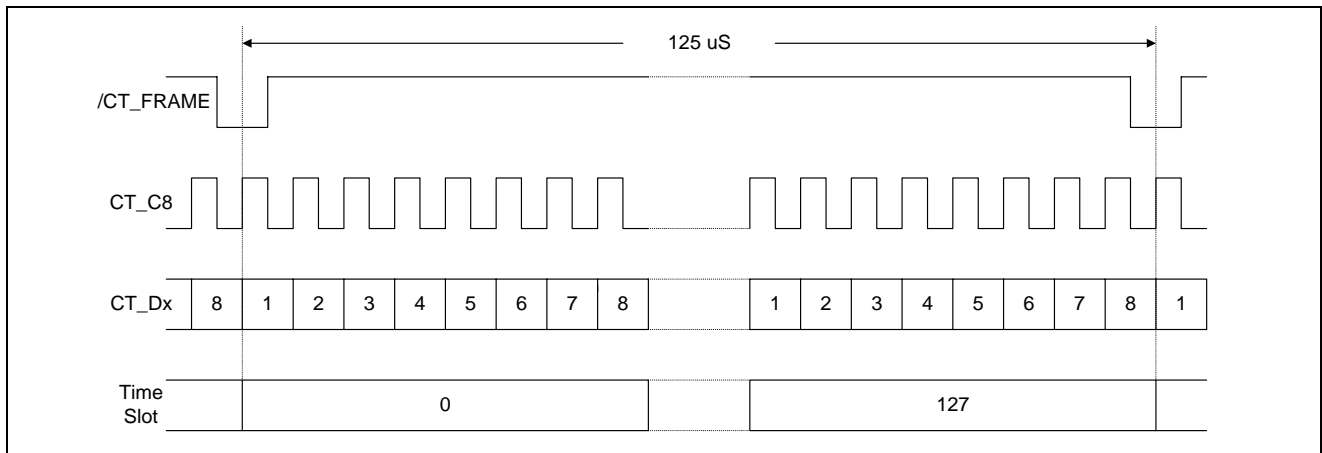

Figure 74 - H.100/H.110 Clocking Signals

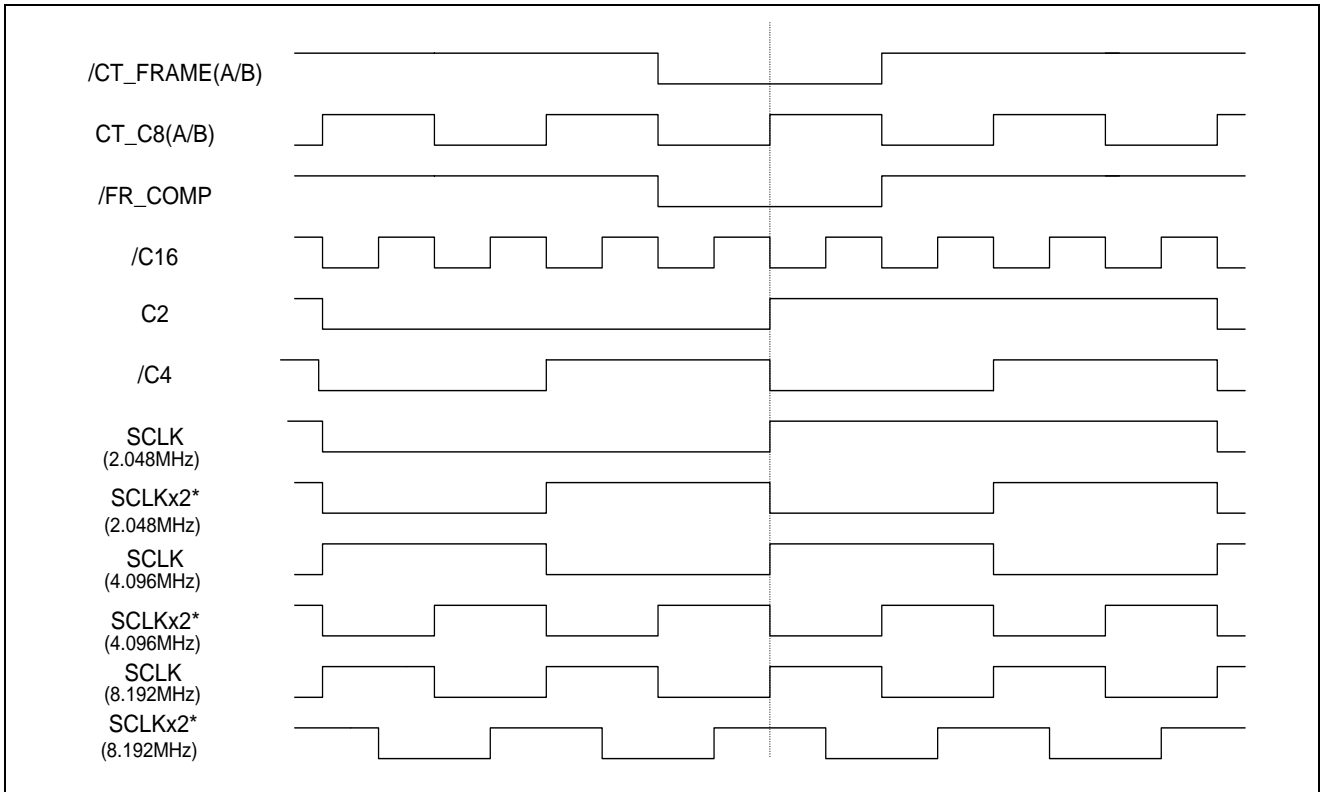

Figure 75 - TDM Bus Timing - Compatibility Clock Generation

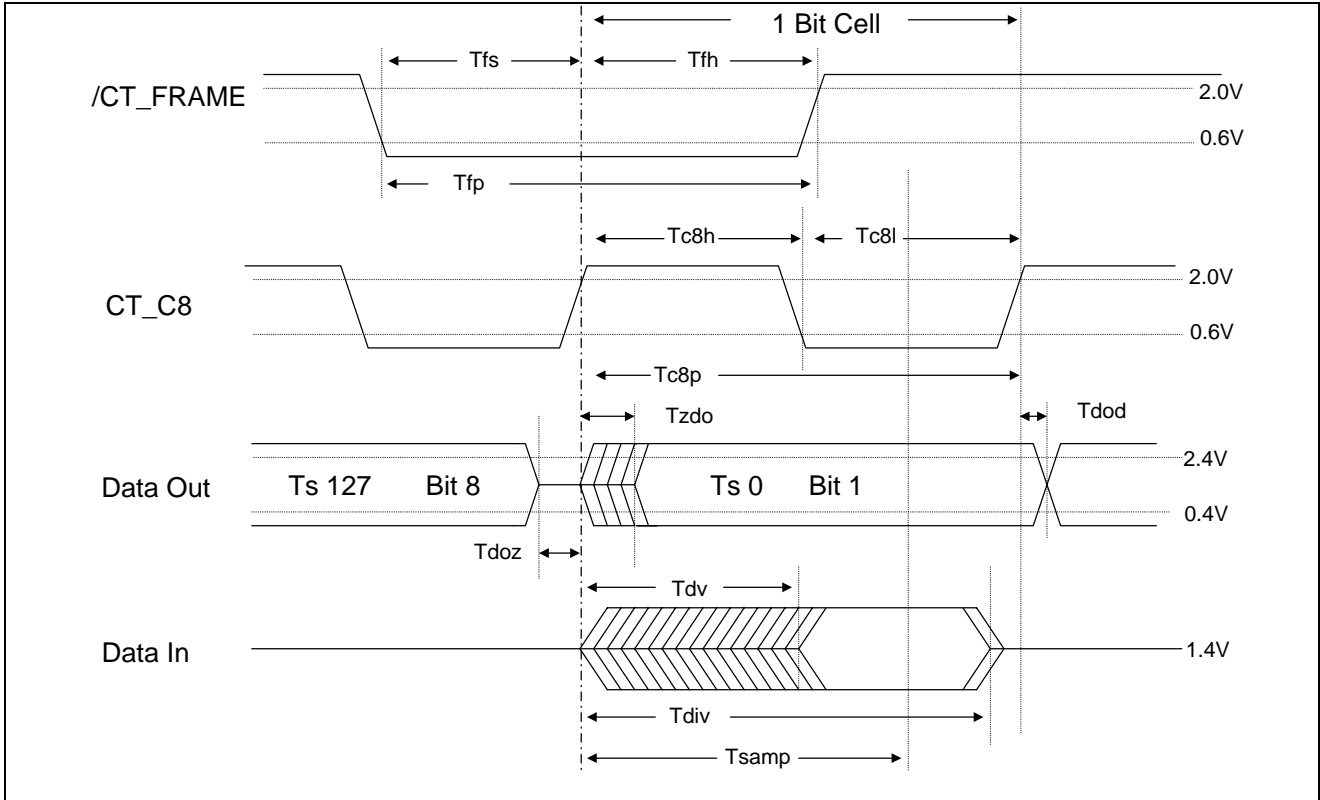

Figure 76 - TDM Data Bus Timings

Symbol	Parameter	Min.	Typ.	Max.	Units
	Clock edge rate (All Clocks)	0.25		2	V/ns
Tc8p	Clock CT_C8 Period	122.066-F		122.074+F	ns
Tc8h	Clock CT_C8 High Time	49-F		73+F	ns
Tc8l	Clock CT_C8 Low Time	49-F		73+F	ns
Tsamp	Data Sample Point		90		ns
Tdoz	Data Output to HiZ Time	-20		0	ns
Tzdo	Data HiZ to Output Time	0		22	ns
Tdod	Data Output Delay Time	0		22	ns
Tdv	Data Valid Time	0		69	ns
Tdiv	Data Invalid Time	102		112	ns
Tfp	/CT_FRAME Width	90	122	180	ns
Tfs	/CT_FRAME Setup Time	45		90	ns
Tfh	/CT_FRAME Hold Time	45		90	ns
F	Phase Correction	0		10	ns

Table 304 - H.100/H.110 Clocking Signals

10.0 Glossary of Terms

AAL0: ATM Adaptation Layer 0. AAL0 is a straight packaging of 48 bytes of data within an ATM cell. AAL0 can be used to treat either data cells (managed by CPU) or CBR cells (managed by TX/RX SAR).

AAL1: ATM Adaptation Layer 1. AAL1 is used to transport constant bit rate (CBR) data on ATM. The main features of AAL1 are a cell sequence number that allows the detection of lost cells and a p-byte that allows reconverging of multi-channel VCs.

AAL5: ATM Adaptation Layer 5. The main feature of AAL5 is a 32-bit CRC at the end of the cell that allows the detection and correction of errors in the data payload. In this design, AAL5 cells are used uniquely to treat CBR information.

ATM: Asynchronous Transfer Mode. ATM is a networking standard based on 53-byte cells and is capable of carrying voice, data and video information simultaneously.

CAS: Channel Associated Signalling. Signalling bits used to indicate the state of the channel.

CBR: Constant Bit Rate. Cells in CBR format are sent out at a regular rate. CBR is applicable to voice channels.

CDV: Cell Delay Variation. When cells arrive on a UTOPIA port, they arrive with a certain delay with respect to when they were sent. CDV is a measure of how much that delay varies on a VC.

CLP: Cell Loss Priority. A 1-bit field in the ATM cell header that corresponds to the loss priority of a cell; cells with CLP = 1 can be discarded in a congestion situation.

CNT: Counter. Events in the MT90503 will cause the counter to increment.

CRC: Cyclic Redundancy Check. The CRC is a method of error detection and correction that is applied to a certain field of data. CRC is an efficient method of error detection because the odds of erroneously detecting a correct payload are low.

DS1: Digital-Signal Level 1. DS1 is an electrical interface for digital transmissions that contains 24 64-Kbps channels. The physical interface defined to carry DS1 channels is T1.

E1: E1 is the European equivalent of T1. They are similar with the main difference being E1 runs at 2.048 MHz instead of 1.544 Mbps, carrying 30 64kbps channels.

ESF: Extended Super-Frame. ESF is a T1 format that defines multiframes as consisting of 24 frames, each one of which contains 1 byte per channel.

FASTCAS: FASTCAS is not an acronym. It is capitalised in this document because it is a reserved word. FASTCAS means that multiframe integrity is not respected between the TDM and ATM buses. The TDM data is processed as soon as it is received, while CAS is sent when it is available.

FIFO: First In, First Out. A FIFO memory is one in which the first byte to have been written into the memory is the first one to be read from the read port.

GFC: Generic Flow Control. The GFC field is kept in the 4 highest bits of an ATM cell's header and is used for local functions (not carried end-to-end). The default value is "0000", meaning that GFC protocol is not enforced.

GPI: General Purpose Input

GPI/O: General Purpose Input or Output

H.100/H.110: A TDM bus standard developed by ECTF to provide backward compatibility to existing TDM buses with more bandwidth and potential for development.

HEC: Header Error Check. Using the fifth octet in the ATM cell header, ATM equipment may check for an error and correct the contents of the header. A CRC algorithm allows for single-error correction and multiple-error detection.

IE: Interrupt Enable. This is a register bit that enables a status event to generate an interrupt. This bit is always active-high.

ISR: Interrupt Service Routine

JTAG: Joint Test Action Group.

LUT: Look-Up Table. In the UTOPIA module of the MT90503, the LUT is used to associate the data from received cells with the proper TDM output channels. The LUT is contained in the external memory.

MFS: Multi-Frame Support. The MT90503 is capable of supporting the multi-frame standards of E1 and T1.

MVIP: Multi-Vendor Integration Protocol. MVIP is a standard for transmitting data on a TDM bus.

NNI: Network-Node Interface. NNI ATM cells do not have a GFC nibble, instead having an extra nibble of VPI.

OAM: Operations Administration and Maintenance. MSB within the PTI field of the ATM cell header which indicates if the ATM cell carries management information such as fault indications.

OC-3: Optical Carrier level-3. A Sonet channel that carries a bandwidth of 155.55 Mbps.

OC-12: Optical Carrier level-12. A Sonet channel that carries a bandwidth of 622.08 Mbps.

PC: Process Control bit. This is a register bit type that is written to '1' to initiate a hardware process. When the process completes, the hardware clears the bit.

PCM: Pulse Code Modulation. PCM is the basic method of encoding an analog voice signal into digital form.

PHY: PHYSical layer. The bottom layer of the ATM Reference Model, it provides ATM cell transmission over the physical interfaces that interconnect the various ATM devices.

PLL: Phase Lock Loop. A phase lock loop is a component that generates an output clock by synchronising itself to an input clock. PLLs are often used to multiply the frequency of clocks.

PTI: Payload Type Identifier. The PTI field is a 3-bit header field that encodes various cell management information. Bit 2 (MSB) indicates OAM information or user data, bit 1 is Explicit Forward Congestion Control Indication (whether the cell may have been delayed by network congestion -- never examined by the MT90503) and bit 0 (LSB) indicates that a CBR-AAL5 cell is the final cell in a frame.

PUL: PULse bit. This is a register bit that is written to '1' to indicate an event to the hardware. This bit is always read at '0'.

RAM: Random Access Memory. RAM is the main memory in the computer. It is called "random" because any random address can be accessed in an equal amount of time.

RO: Read Only. This serves to define registers that cannot be written to by the CPU.

ROL: Read Only Latch. This defines status bits. Status bits cannot be written to '1' by the CPU; however, once the status bit is set, the CPU can clear it by writing a '0' over it.

RW: Read Write. This type of register bit will be readable and writeable by the CPU.

SAR: Segmentation And Reassembly. Method of partitioning, at the source, frames into ATM cells and reassembling, at the destination, these cells back into information frames; lower sublayer of the AAL which inserts data from the information frames into cells and then adds the required header, trailer, and/or padding bytes to create 48-byte payloads to be transmitted to the ATM layer.

SCSA: Signal Computing System Architecture

SRTS: Synchronous Residual Time Stamp. SRTS is a clock recovery technique, which transmits timing information over the network to allow the source clock to be reconstructed at the other end. SRTS is sent in a 4-bit value transmitted over 8 AAL1 cells.

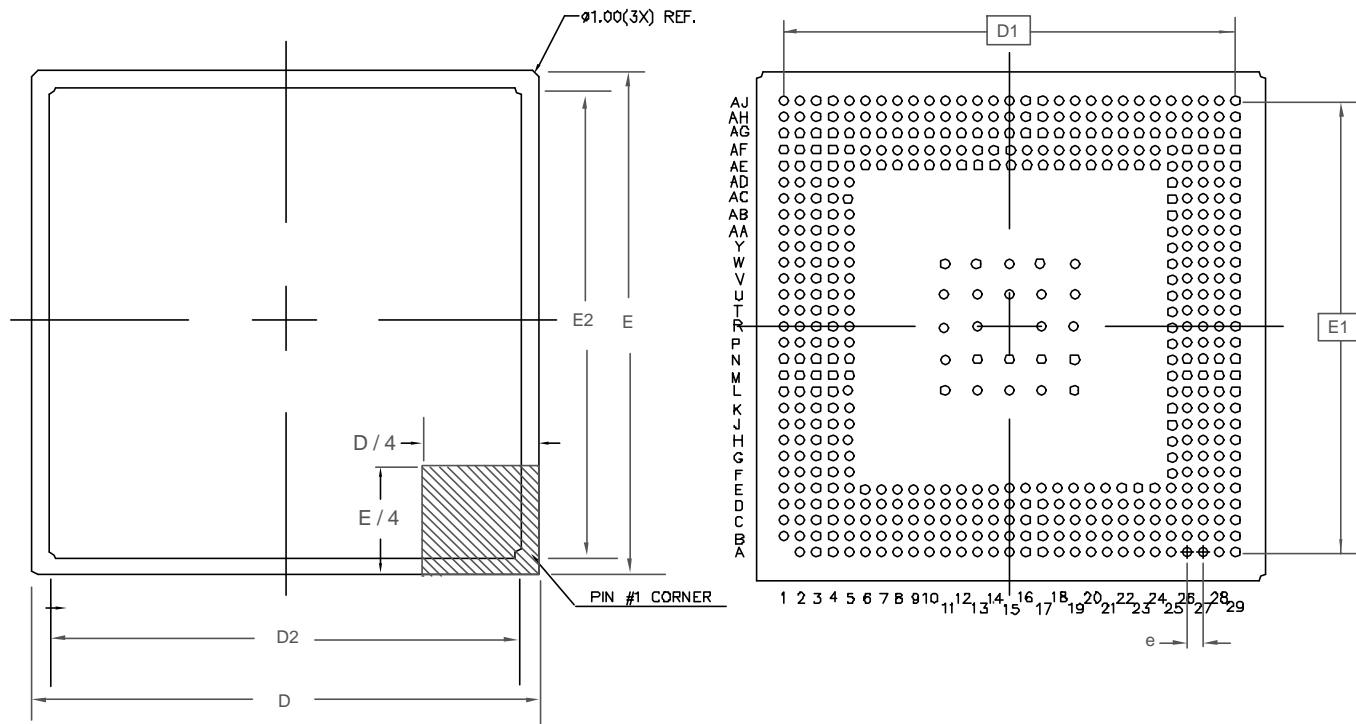

DIMENSION	MIN	MAX
A	2.11	2.56
A1	0.50	0.70
A2	1.10	1.25
D	39.80	40.20
D1	35.56 REF	
D2	37.50	39.50
E	39.80	40.20
E1	35.56 REF	
E2	37.50	39.50
b	0.60	0.90
e	1.27	
N	503	
Conforms to JEDEC MS - 034		

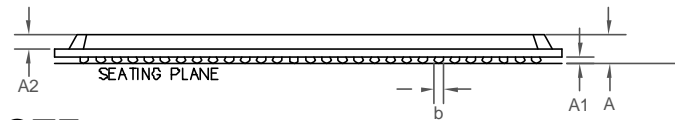

NOTE:

1. CONTROLLING DIMENSIONS ARE IN MM
2. DIMENSION "b" IS MEASURED AT THE MAXIMUM SOLDER BALL DIAMETER
3. SEATING PLANE IS DEFINED BY THE SPHERICAL CROWNS OF THE SOLDER BALLS.
4. N IS THE NUMBER OF SOLDER BALLS
5. NOT TO SCALE.
6. SUBSTRATE THICKNESS IS 0.56 MM REF

© Zarlink Semiconductor 2002 All rights reserved.

ISSUE	1			
ACN	214212			
DATE	04APR03			
APPRD.				



Previous package codes:

BP / G

Package Code GK

Package Outline for 503 Ball BGA (40x40x2.33mm)

GPD00839



**For more information about all Zarlink products
visit our Web Site at
www.zarlink.com**

Information relating to products and services furnished herein by Zarlink Semiconductor Inc. or its subsidiaries (collectively "Zarlink") is believed to be reliable. However, Zarlink assumes no liability for errors that may appear in this publication, or for liability otherwise arising from the application or use of any such information, product or service or for any infringement of patents or other intellectual property rights owned by third parties which may result from such application or use. Neither the supply of such information or purchase of product or service conveys any license, either express or implied, under patents or other intellectual property rights owned by Zarlink or licensed from third parties by Zarlink, whatsoever. Purchasers of products are also hereby notified that the use of product in certain ways or in combination with Zarlink, or non-Zarlink furnished goods or services may infringe patents or other intellectual property rights owned by Zarlink.

This publication is issued to provide information only and (unless agreed by Zarlink in writing) may not be used, applied or reproduced for any purpose nor form part of any order or contract nor to be regarded as a representation relating to the products or services concerned. The products, their specifications, services and other information appearing in this publication are subject to change by Zarlink without notice. No warranty or guarantee express or implied is made regarding the capability, performance or suitability of any product or service. Information concerning possible methods of use is provided as a guide only and does not constitute any guarantee that such methods of use will be satisfactory in a specific piece of equipment. It is the user's responsibility to fully determine the performance and suitability of any equipment using such information and to ensure that any publication or data used is up to date and has not been superseded. Manufacturing does not necessarily include testing of all functions or parameters. These products are not suitable for use in any medical products whose failure to perform may result in significant injury or death to the user. All products and materials are sold and services provided subject to Zarlink's conditions of sale which are available on request.

Purchase of Zarlink's I²C components conveys a licence under the Philips I²C Patent rights to use these components in and I²C System, provided that the system conforms to the I²C Standard Specification as defined by Philips.

Zarlink, ZL and the Zarlink Semiconductor logo are trademarks of Zarlink Semiconductor Inc.

Copyright Zarlink Semiconductor Inc. All Rights Reserved.

TECHNICAL DOCUMENTATION - NOT FOR RESALE
