



MTC20154

INTEGRATED ADSL CMOS ANALOG FRONT-END CIRCUIT

Features

- Fully integrated AFE for ADSL
- Overall 12 bit resolution, 1.1MHz signal bandwidth
- 8.8 MS/s ADC
- 8.8 MS/s DAC
- THD: -60 dB @ full scale
- 1V full scale input
- Differential analog I/O
- Accurate continuous-time channel filtering
- 3rd & 4th order tunable continuous time LP Filters
- 64 pin TQFP package
- 350mW power consumption

Applications

- ADSL Front-end for all full rate and Lite standards

DESCRIPTION

The MTC20154 is the fifth generation Analog Front End (AFE) designed for DMT based ADSL (Asynchronous Digital Subscriber Line) modems compliant with ANSI T1.413 category 2 standard. It includes one 12 bit DAC and one 13 bit ADC. It is

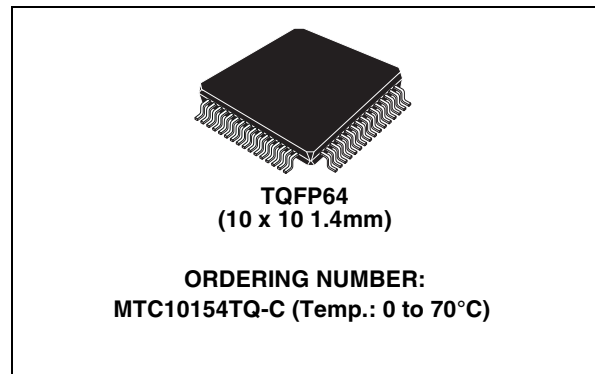

intended to be used with the MTC20156/ MTC20147 DMT/ATM processors as part of the MTK20150/MTK20141 chipsets, but may also be used to support other xDSL signal processors.

The MTC20154 provides programmable low pass filters for each of the two channels and automatic gain control. A configuration pin allows the filters to be switched from ATU-R mode to ATU-C mode. The pipeline ADC architecture provides 13 bit dynamic range and a signal bandwidth of 1.1 MHz. The device consumes only 0.35 Watt in full operation and has a power down mode for standby. It is housed in a compact 64 pin thin plastic quad flat package.

Figure 1. Block Diagram

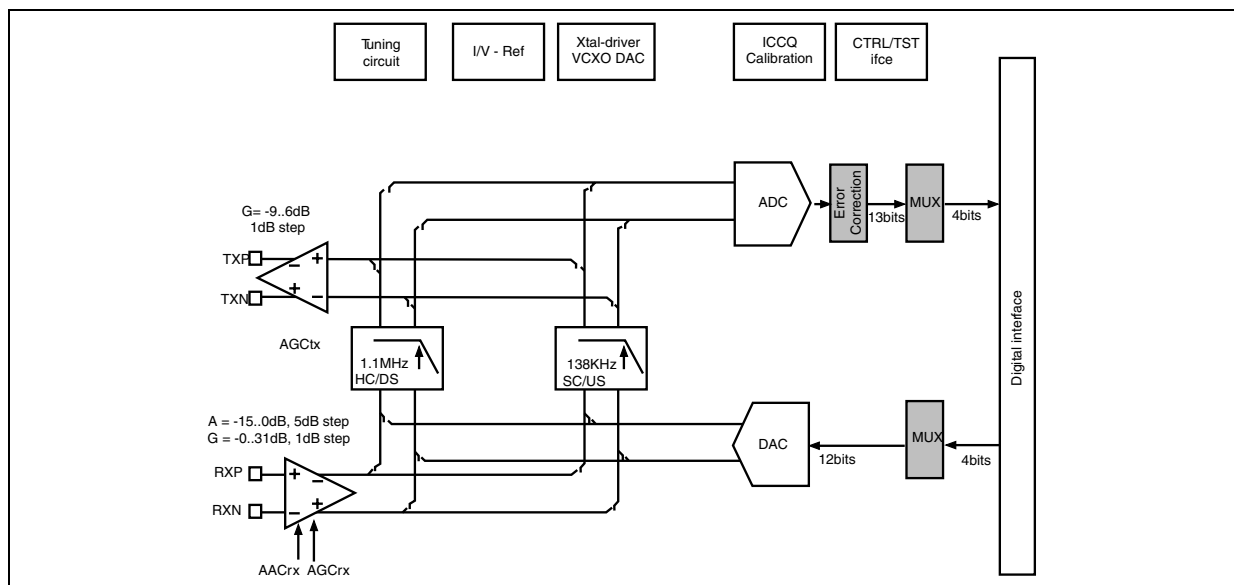

MTC20154

Functional Description

The MTC20154 chip can be used on the ATU-C side (LT), and on the ATU-R (NT) side (defined by LTNT pin). The selection consists mainly of a filter interchange between the RX and TX path. The filters (with a programmable cutoff frequency) use automatic continuous time tuning to avoid time varying phase characteristics which can be of dramatic consequence for DMT modems. It requires few external components, uses a 3.3 V supply and is packaged in a 64 pins TQFP in order to reduce PCB area.

The Receiver (RX)

The DMT signal coming from the line to the MTC20154 is first filtered by the two following external filters:

- POTS HP filter: Attenuation of speech and POTS signalling.
- Channel filter: Attenuation of echo signal to improve RX dynamic.

The signal is amplified by a low noise gain stage (-15..+31 dB) then low-pass filtered to avoid anti-aliasing and to ease further digital processing by removing unwanted high frequency out-of-band noise.

A 12 bits A/D converter samples the data at 8.832 MS/s, transforms the signal into a digital representation and sends it to the DMT signal processor via the digital interface.

The Transmitter (TX/TXE)

The 12 bits data at 8.832 Ms coming from the DMT signal processor through the digital interface are transformed by a D/A converter into an analog signal. This signal is then filtered to decrease DMT sidelobes levels and meet the ANSI transmitter spectral response but also to reduce the out-of-band noise (which can be echoed to the RX path) to an acceptable level. The pre-driver buffers the signal for the external line driver and in case of short loops provide attenuation provision (-9..+6 dB).

The VCXO

The VCXO is divided in a XTAL driver and an auxilliary 8 bits DAC for timing recovery.

The XTAL driver is able to operate at 35.328 MHz or 17.664 MHz. An internal PLL will be used to double the frequency in the 17.664 MHz case. It also provides an amplitude regulation mechanism to avoid temperature/-supply/technology dependent frequency pulling.

The DAC which is driven by the CTRLIN pin provides a current output with 8 bits resolution and can be used to tune the XTAL frequency with the help of external components. A time constant between DAC input and VCXO output can be introduced (via the CTRLIN interface) and programmed with the help of an external capacitor (on VCOCAP pin).

The Digital Interface

The digital part of the MTC20154 can be divided into two parts: The data interface converts the multiplexed data from/to the DMT signal processor into a valid representation for the TX DAC and RX ADC. The control interface allows the board processor to configure the MTC20154 paths (RX/TX gains, filter band, ...) or settings.

Package

The MTC20154 is housed in a 64-pin TQFP package.

Pin Assignment

Table 1. Pinning Description MTC20154 AFE

Pin	Name	Description	Connection	Type	Dir.	Main characteristics
Digital interface						
64	DVSS	Negative supply for input I/Os + core	Dig supply	Direct	Bi	$Z = 0 \cong \Omega$
1	TX3	Transmit data bus bit 3 (MSB)	MTC20156/146/147	Schmitt	In	high Z
2	TX2	Transmit data bus bit 2	MTC20156/146/147	Schmitt	In	high Z
3	TX1	Transmit data bus bit 1	MTC20156/146/147	Schmitt	In	high Z
4	TX0	Transmit data bus bit 0 (LSB)	MTC20156/146/147	Schmitt	In	high Z
5	CTRLIN	Serial control interface input	MTC20156/146/147	Schmitt	In	high Z
6	DVDD	Positive supply for input I/Os + core	Dig supply	Direct	Bi	$Z = 0 \cong \Omega$
7	DVDD	Positive supply for output I/Os	Dig supply	Direct	Bi	$Z = 0 \cong \Omega$
8	CLKM	Master clock output	System	Tristate	Out	$I_{max} = 4 \text{ mA}$ $C_{max} = 100 \text{ pF}$
9	CLKWD	Word clock output	System	Tristate	Out	$I_{max} = 4 \text{ mA}$ $C_{max} = 100 \text{ pF}$
10	RX3	Receive data bus bit 3 (MSB)	MTC20156/146/147	Tristate	Out	$I_{max} = 4 \text{ mA}$ $C_{max} = 100 \text{ pF}$
11	RX2	Receive data bus bit 2	MTC20156/146/147	Tristate	Out	$I_{max} = 4 \text{ mA}$ $C_{max} = 100 \text{ pF}$
12	RX1	Receive data bus bit 1	MTC20156/146/147	Tristate	Out	$I_{max} = 4 \text{ mA}$ $C_{max} = 100 \text{ pF}$
13	RX0	Receive data bus bit 0 (LSB)	MTC20156/146/147	Tristate	Out	$I_{max} = 4 \text{ mA}$ $C_{max} = 100 \text{ pF}$
14	PD	General power down	System	Tristate	Out	$I_{max} = 4 \text{ mA}$ $C_{max} = 100 \text{ pF}$
15	DVSS	Negative supply for output I/Os	Dig supply	Direct	Bi	$Z = 0 \cong \Omega$
16	RESET	General reset (active low)	System	Schmitt	In	High Z
Analog interface						
17	AVSSADC	ADC analog negative supply	Ana supply	Direct	Bi	$Z = 0 \cong \Omega$
18	DRVSD	External TX driver shutdown	TX driver	Tristate	Out	$I_{max} = 4 \text{ mA}$ $C_{max} = 100 \text{ pF}$
19	DRV1	External TX driver bias control MSB	TX driver	Tristate	Out	$I_{max} = 4 \text{ mA}$ $C_{max} = 100 \text{ pF}$
20	DRV0	External TX driver bias control LSB	TX driver	Tristate	Out	$I_{max} = 4 \text{ mA}$ $C_{max} = 100 \text{ pF}$
22	VREF	ADC virtual ground decoupling	C network	Analog	Bi	NoDC current



MTC20154**Table 1. Pinning Description MTC20154 AFE (continued)**

Pin	Name	Description	Connection	Type	Dir.	Main characteristics
23	VRAN	ADC negative reference decoupling	C network	Analog	Bi	NoDC current
24	VRAP	ADC positive reference decoupling	C network	Analog	Bi	NoDC current
25	AVDDADC	ADC analog positive supply	Ana supply	Direct	Bi	$Z = 0 \cong \Omega$
29	AVDD TXDRV	Internal TX pre--driver positive supply	Ana supply	Direct	Bi	$Z = 0 \cong \Omega$
30	TXN	Analog TX signal negative output (diff)	TX output	Analog	Out	V com = VDD/2
31	TXP	Analog TX signal positive output (diff)	TX output	Analog	Out	V com = VDD/2
32	AVSS TXDRV	Internal pre--driver negative supply	Ana supply	Direct	Bi	$Z = 0 \cong \Omega$
33	GP3	Analog general purpose control pin	Board	Tristate	Out	I _{max} = 4 mA C _{max} = 100 pF
34	GP2	Analog general purpose control pin	Board	Tristate	Out	I _{max} = 4 mA C _{max} = 100 pF
35	GP1	Analog general purpose control pin	Board	Tristate	Out	I _{max} = 4 mA C _{max} = 100 pF
36	GP0	Analog general purpose control pin	Board	Tristate	Out	I _{max} = 4 mA C _{max} = 100 pF
39	AVDDFILT	Filter analog positive supply	Ana supply	Direct	Bi	$Z = 0 \cong \Omega$
40	AGND	Analog virtual ground	C network	Analog	Bi	NoDC current
43	AVSSFILT	Filter analog negative supply	Ana supply	Direct	Bi	$Z = 0 \cong \Omega$
44	AVSSLNA	LNA analog negative supply	Ana supply	Direct	Bi	$Z = 0 \cong \Omega$
48	AVDDLNA	LNA analog positive supply	Ana supply	Direct	Bi	$Z = 0 \cong \Omega$
50	RXN	Analog RX signal negative input (diff)	RX input	Analog	In	V com forced at VDD/2
51	RXP	Analog RX signal positive input (diff)	RX input	Analog	In	V com forced at VDD/2
52	XTAL bypass	Crystal oscillator bypass selection pin	Strap	Schmitt	In	High Z
53	PLL	PLL enable/disable selection pin	Strap	Schmitt	In	High Z
54	DACVREF	DAC voltage reference decoupling	C network	Analog	Bi	NoDC current
55	AVDDDAC	DAC analog positive supply	Ana supply	Direct	Bi	$Z = 0 \cong \Omega$
56	AVDD XTAL	Crystal driver analog positive supply	Ana supply	Direct	Bi	$Z = 0 \cong \Omega$
57	XTALO	Crystal driver connection 1	Crystal	Analog	Bi	X cap sensitive
58	XTALI	Crystal driver connection 2	Crystal	Analog	Bi	X cap sensitive

Table 1. Pinning Description MTC20154 AFE (continued)

Pin	Name	Description	Connection	Type	Dir.	Main characteristics
59	AVSS XTAL	Crystal driver analog negative supply	Ana supply	Direct	Bi	$Z = 0 \cong \Omega$
60	AVSSDAC	DAC analog negative supply	Ana supply	Direct	Bi	$Z = 0 \cong \Omega$
61	IVCO	VCO steering current reference	VCO	Analog	Bi	DC current
62	VCOcap	VCO external capacity connection	Capacity	Analog	Bi	No Dc current
63	VCXOI	VCO steering current output	VCO	Analog	Bi	DC current
Mode selection interface						
26	LTNT	Mode selection: LT or NT (static)	Strap	Schmitt	In	high Z
27	TEST	Test mode selection (static)	Strap	Schmitt	In	high Z
Analog test access interface						
41	T2N	Neg. diff input/output test access	Test	Analog	Bi	$V_{com} = VDD/2$
42	T2P	Pos. diff. input/output test access	Test	Analog	Bi	$V_{com} = VDD/2$
46	T1P	Pos. diff output test access	Test	Analog	Out	$V_{com} = VDD/2$
47	T1N	Neg. diff output test access	Test	Analog	Out	$V_{com} = VDD/2$

Figure 2. MTC20154 Grounding and Decoupling Networks

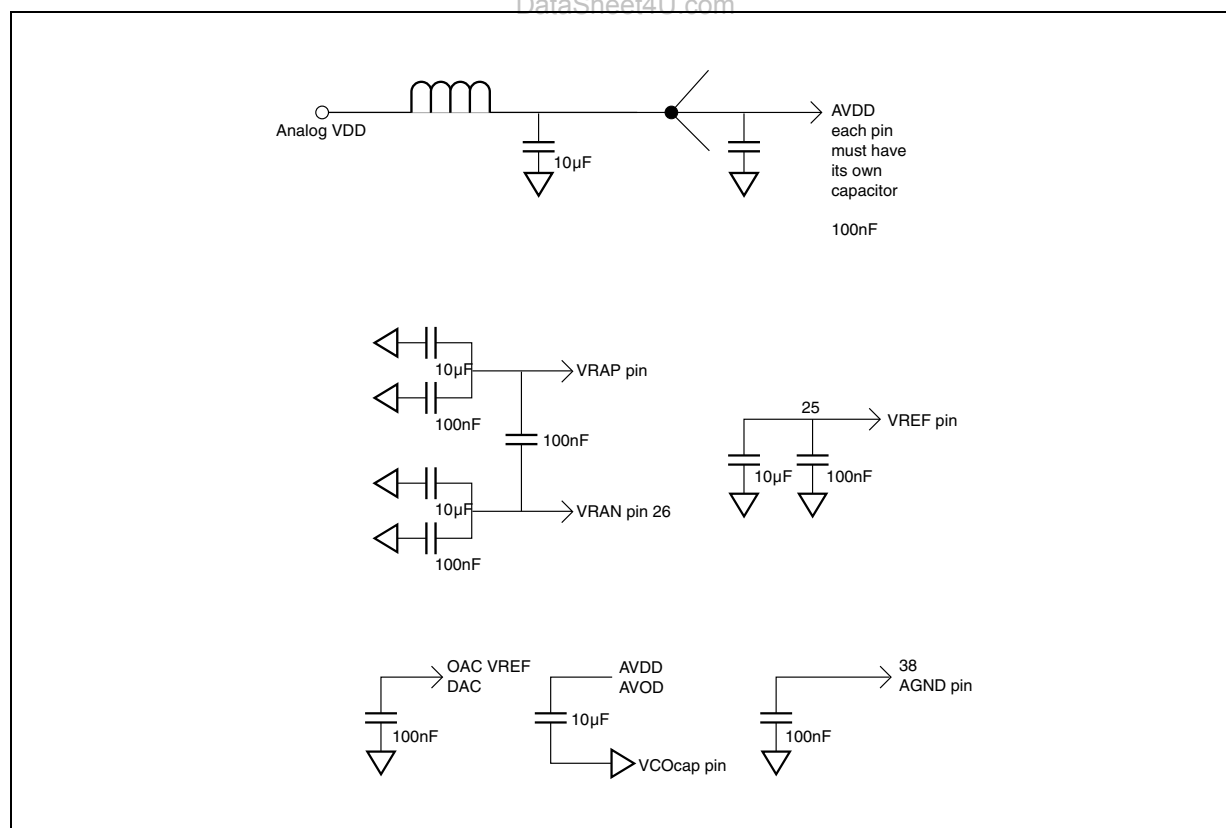

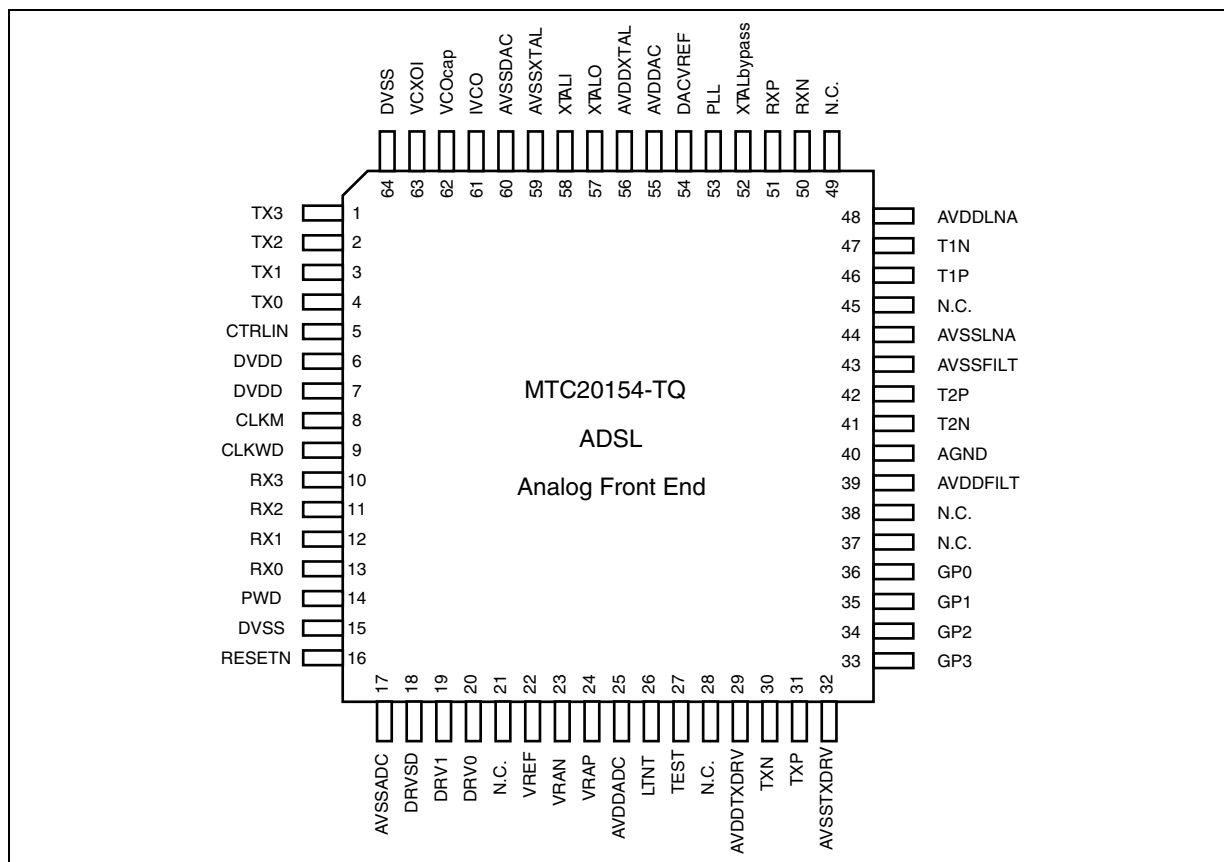
MTC20154**Figure 3. Pin connection (Top view)****ELECTRICAL RATINGS AND CHARACTERISTICS****Absolute Maximum Ratings**

Operation of the device beyond these limits may cause permanent damage. It is not implied that more than one of these conditions can be applied simultaneously.

Table 2. Electrical Characteristics

Symbol	Parameter	Min.	Typ.	Max.	Unit
V_{DD}	Any V_{DD} supply voltage, related to substrate	-0,5		5	Vhh
V_{in}	Voltage at any input pin	-0,5		$V_{DD} + 0.5$	V
T_{stg}	Storage Temperature	-40		125	°C
T_L	Lead Temperature (10 second soldering)			300	°C
P_d	Power Dissipation	350	350	500	mW
T_j	Junction Temperature	-40		110	°C

Operating Conditions

Unless specified, the characteristic limits of 'Static characteristics' in this document apply for the following operating conditions:

Table 3. Operating conditions

Symbol	Parameter	Min.	Max.	Unit
AVDD	AVDD supply voltages, related to substrate	3.0	3.6	V
DVDD	DVDD supply voltages, related to substrate	2.7	3.6	V
V _{in} , V _{out}	Voltage at any input and output pin	0	VDD	V
T _{amb}	Ambient Temperature - I version	-40	85	°C
T _{amb}	Ambient Temperature - C version	0	70	°C

Static Characteristics

Digital Inputs

Schmitt-trigger inputs: TXi, CTRLIN, PDOWN, LTNT, RESETN, TEST

Table 4. Digital Inputs

Symbol	Parameter	Min.	Max.	Unit
VIL	Low level input voltage		0.2*DVDD	V
VIH	High level input voltage	0.8*DVDD		V
VH	Hysteresis	1.0	1.3	V
Cinp	Input capacitance		3	pF

Digital Outputs

Hard driven outputs: RXi, CLKWD, GPI, DRVI, DRVSD

Table 5. Digital Outputs

Symbol	Parameter	Test Condition	Min.	Max.	Unit
VOL	Low level output voltage	I _{out} = -4 mA		.15*DVDD	V
VOH	High level output voltage	I _{out} = 4mA	.85*DVDD		V
Cload	Load capacitance			30	pF

Clock Driver output: CLKM

Table 6. Clock Driver output

Symbol	Parameter	Test Condition	Min.	Max.	Unit
VOL	Low level output voltage	I _{out} = -4 mA		.15*DVDD	V
VOH	High level output voltage	I _{out} = 4mA	.85*DVDD		V
Cload	Load capacitance			30	pF
Dcycle	Duty cycle		45	55	%



MTC20154**Analog TX/RX Signals**

The reference impedance for all power calculations is 100Ω.

DMT Signal

A DMT signal is basically the sum of N independently QAM modulated signals, each carried over a distinct carrier. The frequency separation of each carrier is 4.3125 KHz with a total number of 256 carriers (ANSI). For large N, the signal can be modelled by a gaussian process with a certain amplitude probability density function. Since the maximum amplitude is expected to arise very rarely, the signal is clipped to trade-off the resulting SNR loss against AD/DA dynamic range.

A clipping factor (V_{peak}/V_{rms} = "crest factor") of 5 is used resulting in a maximum SNR of 75 dB. ADSL DMT signals are nominally sent at -40 dBm/Hz +/- 3 dB (-3.65 dBm/carrier) with a maximal power of 100 mW for downlink transmitter and 4.5 mW for uplink transmitter.

The minimum SNR+D needed for DMT carrier demodulation is about $(3*N+20)$ dB with a minimum of 38 dB where N is the constellation size of a carrier (in bits).

Table 7. Signal Levels (on the line)

Description	LT side		NT side	
	RX	TX	RX	TX
Max level	839 mVpdif	15.8 Vpdif	3.95 Vpdif	3.4 Vpdif
Max RMS level	168 Vrms	3.16 Vrms	791 mVrms	671 mVrms
Min level	54 mVpdif	3.95 Vpdif	42 mVpdif	839 mVpdif
Min RMS level	11 mVrms	791 mVrms	8 mVrms	168 mVrms

Table 8. Total Signal Level (on the line) DataSheet4U.com

Description	LT side	NT side
	RX	RX
Max level for receiver	4 Vpdif (Long line)	4.2 Vpdif (Short line)

ATU-C Side Block Diagram

The transformer at the ATU-C side has a 1:2 ratio. The termination resistors are 12.5Ω in case of 100Ω lines. The hybrid bridge resistors should be $< 2.5\text{ k}\Omega$ for low-noise.

An HP filter must be used on the TX path to reduce DMT sidelobes and out-of-band noise influence on the receiver.

On the RX path, a LP filter must be used in order to reduce the echo signal level and to avoid saturation of the input stage of the receiver.

The POTS filter is used in both directions to reduce crosstalk between ADSL signals and POTS speech and signalling.

Figure 4. ATU-C AFE Schematics (For detailed schematics see MTB-20150-EBC reference design.)

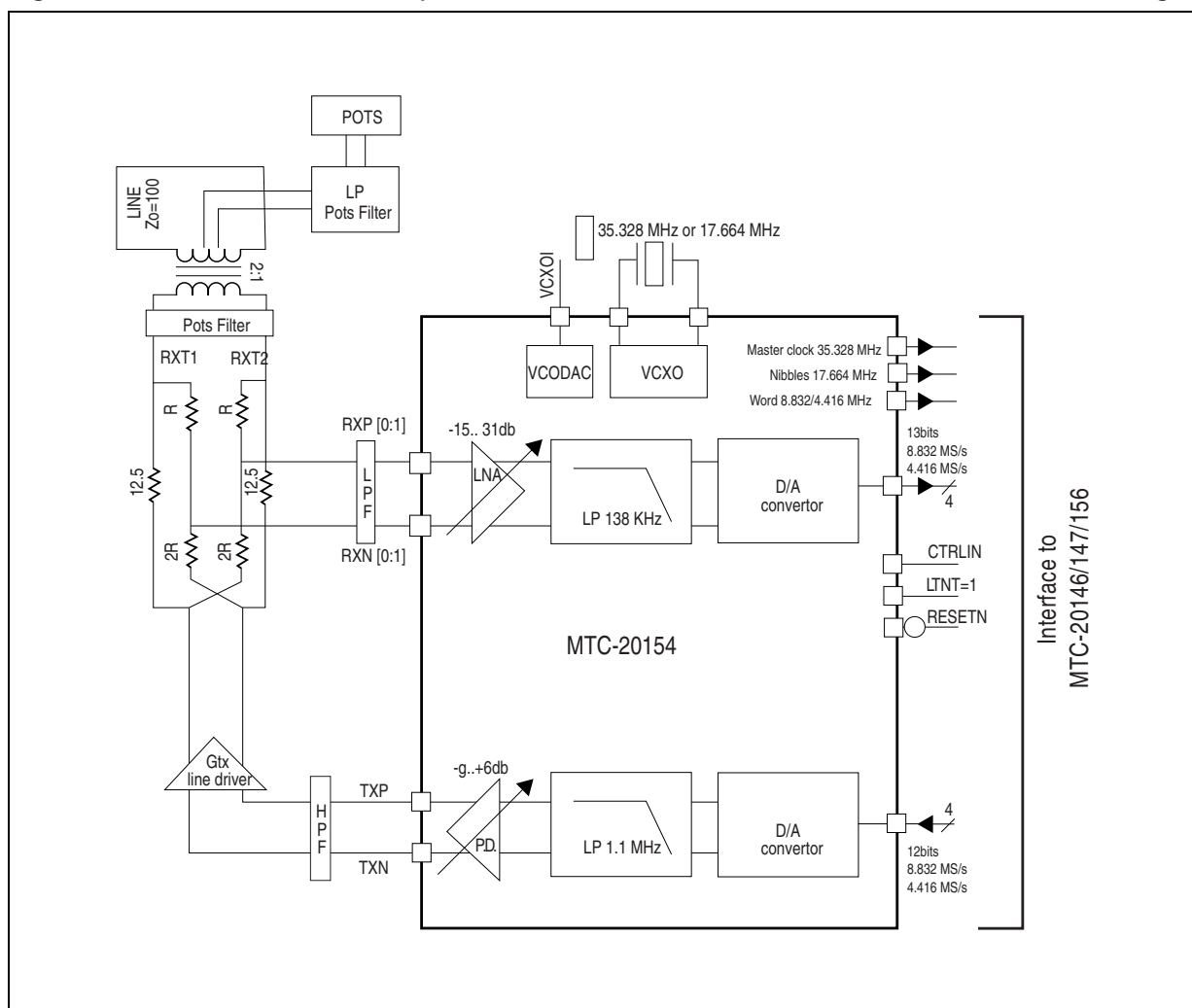

MTC20154

ATU-R Side Block Diagram

The ATU-R side block diagram is equal to the ATU-C side block diagram with the following differences:

- The transformer ratio is 1:1
- Termination resistors are 50Ω for 100Ω lines.

An LP filter may be used on the TX path to reduce DMT sidelobes and out-of-band noise influence on the receiver.

On the RX path, a HP filter must be used in order to reduce the echo signal level and to avoid saturation of the input stage of the receiver.

The POTS filter is used in both directions to reduce crosstalk between ADSL signals and POTS speech and signalling.

Figure 5. ATU-R AFE Schematics (For detailed schematics see MTB-20141-EBR reference design.)

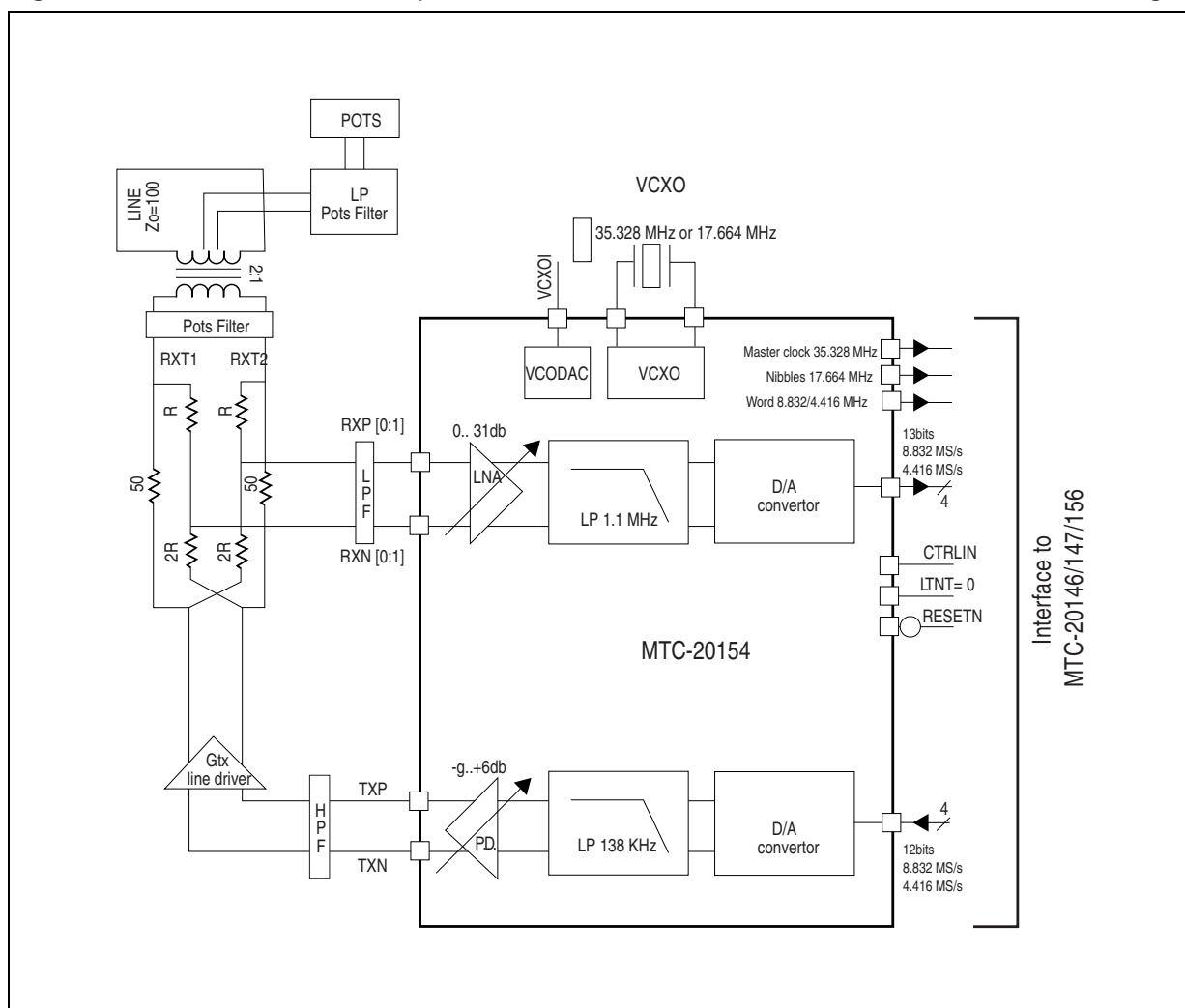

MTC20154 RX PATH

Speech Filter

An external bidirectional LP filter for up and downstream POTS service splits out the speech signal to the analog telephone circuit on both the NT and LT sides of the line. The ADSL analog front end integrated circuit does not contain any circuitry for the POTS service but guarantees that the POTS bandwidth is not disturbed by spurious signals from the ADSL spectrum.

Channel Filters

The purpose of these external analog circuits is to provide partial echo cancellation by analog filtering of the receive signal for both ATU-R (reception of downstream channel) and ATU-C (reception of upstream channel). This is feasible because the upstream and the downstream data can be modulated on separate carriers (FDM).

Signal Attenuator (ATT) and Low Noise Amplifier

The attenuator needs to be DC decoupled from the external circuitry. In fact, it is also used to internally fix the LNA input common mode voltage at the nominal value: $AVDD/2$. This is done by the use of an internal biasing circuit. It is therefore mandatory to decouple the MTC20154 input from any external DC biasing system. The Low Noise Amplifier (LNA) placed after the ATT will be used in combination with the attenuation block. The goal is to obtain a range of RX path input level varying from -15 dB to 31 dB, while maintaining the noise contribution negligible.

Figure 6. Signal Attenuator (ATT) and Low Noise Amplifier

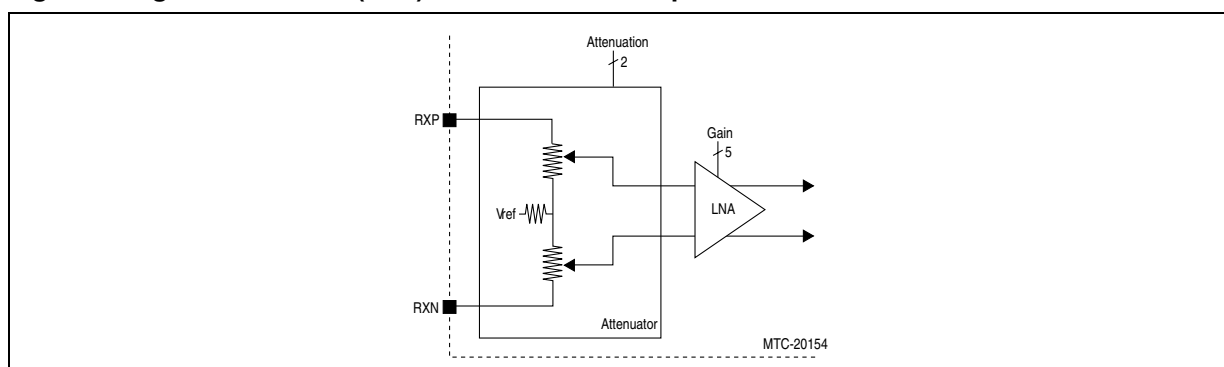

The input attenuator will have the following characteristics

Table 9. Attenuator Characteristics

Data	Min	Typical	Max	Unity
Input type	AC only, DC decoupled	–		
Common mode voltage (forced)	–	$VDD/2$	–	V
Maximum input differential voltage	–	VDD	$VDD+1Vd$	V_{pdiff}
Input impedance	10	14.47	19	KOhms
Attenuation step	–	5	–	dB
Attenuation range	0	–	-15	dB
Maximum attenuation error	–	.05	–	dB
Digital interface	–	2	–	bits
Digital code	'11' → 0 dB attenuation			
	'00' → -15 dB attenuation			

MTC20154**Table 10. LNA characteristics**

Data	Min	Typical	Max	Unity
Input common mode voltage	–	AVDD/2	–	V
Input differential voltage	–	1	–	Vpdiff
Maximum peak input differential voltage	–	1	–	Vpdiff
Output common mode voltage	–	AVDD/2	–	V
Maximum peak output differential voltage	–	1	–	Vpdiff
Amplification step	0.7	1	1.3	dB
Amplification range	0	–	+31	dB
Input referred noise at max gain, min atten. (over a 36 kHz to 1.1 MHz band)	5.5	6.5	8	nV/√Hz
Power consumption	–	32	–	mW
Digital interface	–	5	–	bits
Digital code	'00000' -> 0 dB amplification	'11111' -> +31 dB amplification		

RX Filters

The combination of the external filter (an LC ladder filter typically) with the integrated lowpass filter provides:

- echo reduction to improve dynamic range
- DMT sidelobe and out of band (anti-aliasing) attenuation.
- Anti alias filter (60 dB rejection @ image freq.)

ATU-R-RX filters

The integrated filter characteristics are shown in table 6.

ATU-C-RX Filter

This filter is the same as the one used for ATU-R_TX.

Linearity of RX

Linearity of the RX analog path is defined by the IM3 product of two sinusoidal signals with frequencies f1 and f2 and each with 0.5 Vpd amplitude (total 1 Vpd) at the output of the RX-AGC amplifier (i.e: before the ADC) for the case of minimal AGC setting.

Table 11. Integrated filter characteristics ATU-R-RX

Description	Value/Units
Type	4th order butterworth
Cut-off frequency	1.104 MHz (f0)
Max. in-band ripple	0-2 dB

Table 12. Linearity of ATU-R-RX

f1 (0.5 Vpd) f2 (0.5 Vpd)	300 kHz 200 kHz	500 kHz 400 kHz	700 kHz 600 kHz
S/IM3 (AGC = 0 dB)	59.5 dB @ 100 kHz 53.5 dB @ 400 kHz 43.5 dB @ 700 kHz 42.5 dB @ 800 kHz	59.5 dB @ 300 kHz 48.0 dB @ 600 kHz	48.0 dB @ 500 kHz 42.5 dB @ 800 kHz

Table 13. Linearity of ATU-C-RX

f1 (0,5 Vpd)	80 kHz
f2 (0,5 Vpd)	70 kHz
S/IM3	56.5 dB @60 kHz
(AGC = 20 dB)	56.5 dB @90 kHz

A/D Converter

A pipeline architecture is used for the A/D converter.

Table 14. A/D Converter specifications

Number of bits:	13 bits
Minimum resolution of the A/D converter	11 bits
Linearity error of the A/D converter (range: -6 dB FS)	< 4 LSB (out of 13 bits)
Full scale input range:	1.1 Vpdif (+- 5 % @ 3.3 V)
Sampling rate:	8.832 MHz
Maximum attenuation at 1.1 MHz:	< 0.5 dB without in-band ripple
Latency:	5 sampling clock periods

Power Supply Rejection

The noise on the power supplies for the RX-path must be lower than the following: < 50 mVrms in-band white noise for any AVDD.

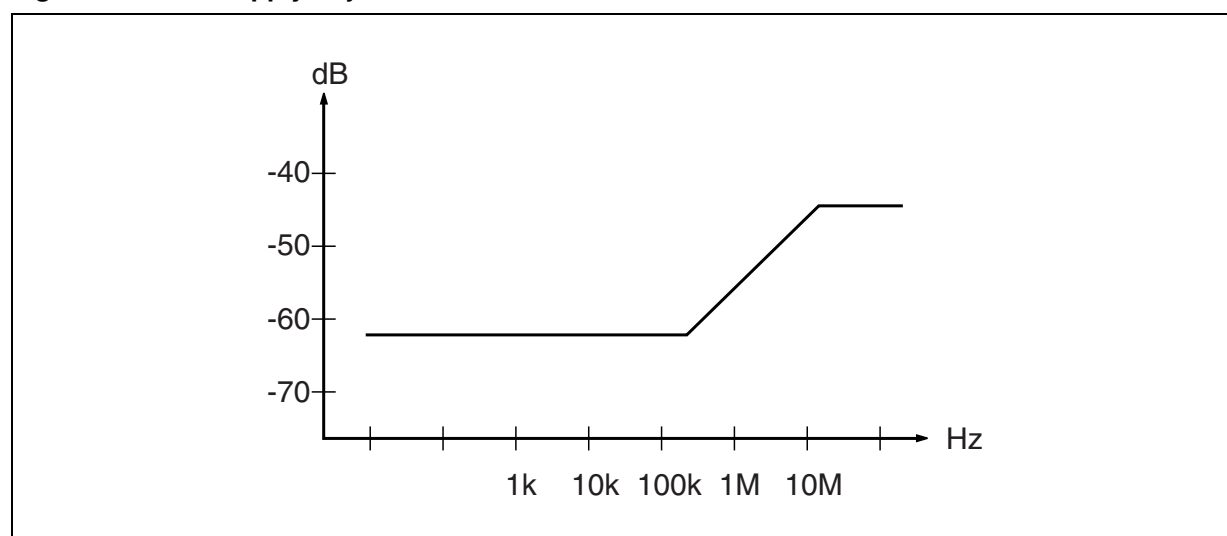
Figure 7. Power Supply Rejection

MTC20154**TX Pre-driver Capability**

The pre-driver drives an external line power amplifier which transmits the required power to the line.

Table 15. Pre-driver characteristics

TX drive level to the external line driver for max AGC setting		2 Vpdif
External line driver input impedance:	resistive	> 200 Ω
	capacitive	< 30 pF
Pre-driver characteristics:		
gain range:	-9 dB...6 dB with step = 1 dB	
common mode voltage:	AVDB/2	
output common mode voltage:	30 nV/Hz	

TX Filter

The TX filters act not only to suppress the DMT sidebands but also as smoothing filters on the D/A converter's output to suppress the image spectrum. For this reason they are realised in a time continuous approach.

ATU-R-TX Filter

The purpose of this filter is to remove out-of-band noise of the ATU-R-TX path echoed to the ATU-R-RX path. In order to meet the transmitter spectral response, additional filtering is (digitally) performed. The integrated filter has nominal characteristics shown in table 11:

Table 16. ATU-R-TX filter characteristics

Description	Value/Units
Input referred noise	94 nV/√Hz
Max. input level	1 Vpd
Max. output level	1 Vpd
Type	4th order chebychef
Cut-off frequency	138 KHz (f0)
Max. in-band ripple	0.5 dB

ATU-C-TX Filter

Same filter as ATU-R-RX. Its purpose is now is to remove image frequency of the transmitted signal according the ANSI definition.

Table 17. D/A Converter

Description	Value/Units
Number of bits:	12 bits
Minimum resolution of the D/A converter	11 bits
Linearity error of the D/A converter	< 1 LSB (out of 12 bits)
Full scale output range:	1 Vpdif +- 5%
Sampling Rate:	8.832 MHz (or 4.416 in alternative mode)
Latency:	1 sampling clock period

Linearity of ATU-C-TX

Linearity of the TX is defined by the IM3 product of two sinusoidal signals with frequencies f_1 and f_2 and each with 0.25 V_{pd} amplitude (-6 dB FS) at the output of the pre-driver for the case of a total AGC = 0 dB.

Table 18. Linearity of ATU-C-TX

f1 (0.25 V _{pd}) f2 (0.25 V _{pd})	300 kHz 200 kHz	500 kHz 400 kHz	700 kHz 600 kHz
S/IM3 (AGC = 0 dB)	59.5 dB @ 100 kHz 53.5 dB @ 400 kHz 43.5 dB @ 700 kHz 42.5 dB @ 800 kHz	59.5 dB @ 300 kHz 45.0 dB @ 600 kHz	48.0 dB @ 500 kHz 42.5 dB @ 800 kHz

Table 19. Linearity of ATU-R-TX

f1 (0.25 V _{pd})	80 k
f2 (0.25 V _{pd})	70 k
S/IM3 (AGC = 0 dB)	59.5 dB (60 k/90 k)

Power Supply Rejection

The noise on the power supplies for the TX-path must be lower than the following: < 50 mVrms in band white noise for AVDD.

< 15 mVrms in band white noise for Pre-driver AVDD.

Voltage Controlled Crystal Oscillator

A voltage controlled crystal oscillator driver is integrated in the MTC20154. Two nominal frequencies can be used: 35.328 MHz or 17.664 MHz. The quartz crystal is connected between the pins XTALI and XTALO.

The principle of the VCXO control is depicted on the figure beside.

Figure 8. Principle of the VCXO control (ATU-R)

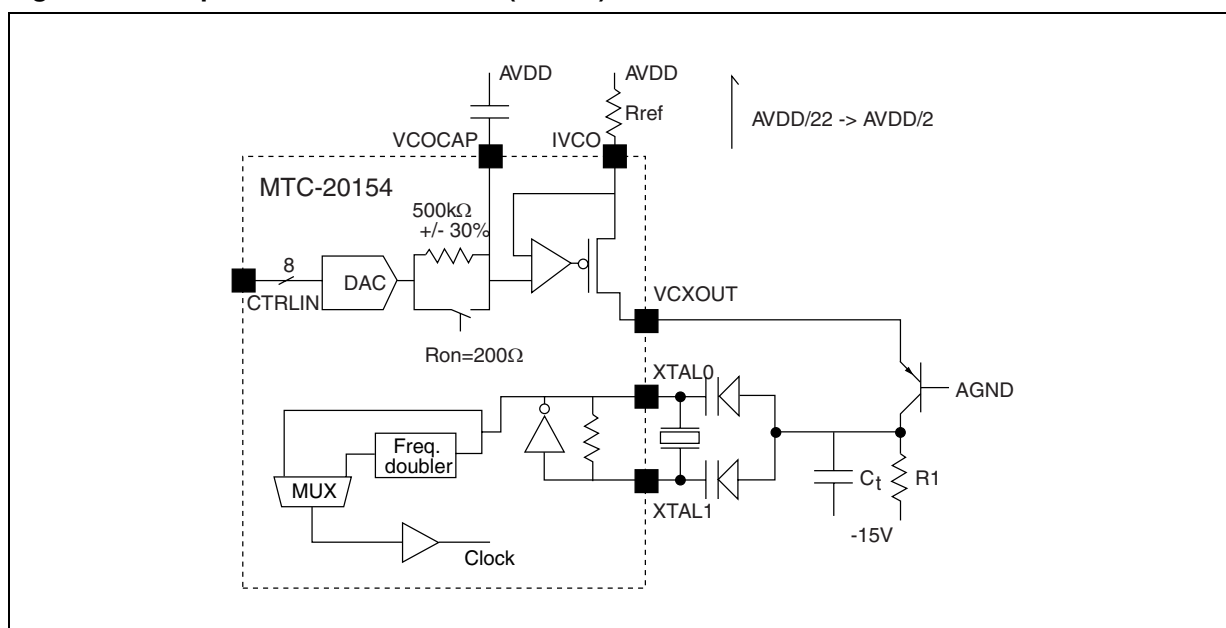

MTC20154

The crystal's exact oscillation frequency can be tuned around the nominal frequency. This is needed in order to allow the system to minimize the clock phase shift between the LT and the NT modems. The information coming from the digital processor via the CTRLIN path is used to drive a 8 bits DAC (resistor ladder architecture) which generates a control current. This current is externally converted and filtered to generate the required control voltage for the varicap. The VCXO characteristics are given in the following table.

Table 20. VCXO characteristics

Data	Min	Typical	Max	Unity
Needed crystal accuracy	50	–	–	ppm
Needed crystal frequency tuning range	100	–	–	ppm
DAC resolution	-	8	-	bit
DAC output voltage range	–	AVDD/2	–	V
DAC differential non linearity error	–	–	1.5	LSB
DAC integrated non linearity error	–	–	4	LSB
VCXO nominal output current (Rref = 16.5 K AVDD = 3.3 V)	95	100	105	mA
Power consumption	–	.225	–	mW

PLL Based Frequency Doubler

Dual crystal frequency can now be used needed when a 17.644 MHz crystal with the MTC20154 on-board crystal is used. A frequency doubler, build driver. However, a master clock up around a Phase Locked Loop (PLL), frequency of 35.328 MHz is still will then be used.

et4U.com

DataSheet4U.com

DataShe

Digital Interface

Control Interface

The digital code setting for the MTC20154 configuration is sent over a serial line (CTRLIN) using the word clock (CLKWD). The data burst is composed of 16 bits from which the first bit is used as start bit ('0'), the three LSBs being used to identify the data contained in the 12 remaining bits. Test related data are latched but they are overruled by the normal settings if the TEST pin is low.

Control Interface Timing

The control interface bits are considered valid on each positive edge of the master clock (CLKM). They will be sampled at this moment. The stop bit will trigger the internal data validation. The timing requirements are depicted in the following figure and table:

Figure 9. Control Interface Timing diagram

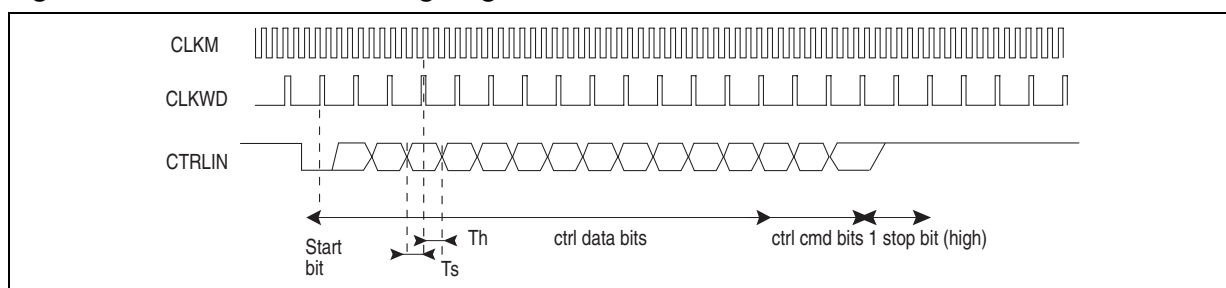

Table 21. Receive / Transmit Protocol

Symbol	Parameters	min	typ	max	Remarks
Ts	Setup Time	7 ns	–	–	
Th	Hold time	0.2 ns	–	–	
TDv	Data Valid	0.5 ns	–	4 ns	

Data set up and hold time are specified versus rising edge of CLKM

Receive / Transmit Interface

The digital interface is based on a 4 * 8.832 MHz (35.328 MHz) clock. The 8.832MHz 12 bits A/D output signal or the D/A input signal are SIPO multiplexed over 4 parallel 35.328 MHz data lines in the following table.

If OSR = 2 bit is selected, CLKNIB is used as nibble clock (17.664 MHz, disabled in normal mode), and all the RXi, TXi, CLKWD periods are twice as long as in normal mode.

Table 22. Receive / Transmit Protocol

	N0	N1	N2	N3
RXD0 / TXD0 will contain	b0	b4	b8	b12
RXD1 / TXD1 will contain	b1	b5	b9	b13
RXD2 / TXD2 will contain	b2	b6	b10	b14
RXD3 / TXD3 will contain	b3	b7	b11	b15

et4U.com

TX / TXE Signal Dynamic Range

DataSheet4U.com

DataShe

The dynamic range of the signal for both DACs is 12 bits extracted from the available signed 16 bit representation coming from the digital processor. The maximal positive number is $2^{14}-1$, the most negative number is -2^{14} , the 3 LSBs are ignored. Any signal exceeding these limits is clamped to the maximal value.

Figure 10. TX/TXE Bit Map

sign	sign	b10	b9	b8	b7	b6	b5	b4	b3	b2	b1	b0	n.u.	n.u.	n.u.
------	------	-----	----	----	----	----	----	----	----	----	----	----	------	------	------

RX Signal Dynamic Range

The dynamic range of the signal from the ADC is limited to 13 bits. Those bits are converted to a signed representation with a maximal positive number of $2^{14}-1$ and a most negative number of 2^{14} . The 2 LSBs are filled with '0'.

Figure 11. RX Bit Map

sign	b12	b11	b10	b9	b8	b7	b6	b5	b4	b3	b2	b1	b0	0	0
------	-----	-----	-----	----	----	----	----	----	----	----	----	----	----	---	---

MTC20154

Receive / Transmit Interface Timing

This interface is a triple (RX, TX, TXE) nibble-serial interface running at 8.8 MHz sampling (normal mode). The data are represented in 16 bits format, and transferred in groups of 4 bits (nibbles). The LSBs are transferred first. The MTC20154 generates a nibble clock (= master clock in normal mode, CLKNIB in OSR = 2 mode) and word signals shared by the three interfaces.

Data is transmitted on the rising edge of the master clock (CLKM/CLKNIB) and sampled on the low going edge of CLKM/CLKNIB. This holds for the data stream from MTC20154 and from the digital processor.

Data, CLWD setup and hold times are 5 ns with reference to the falling edge of CLKM/CLKNIB.

RXD is sampled with CLKM rising edge.

Figure 12. TX/TXE/RX Digital Interface Timing

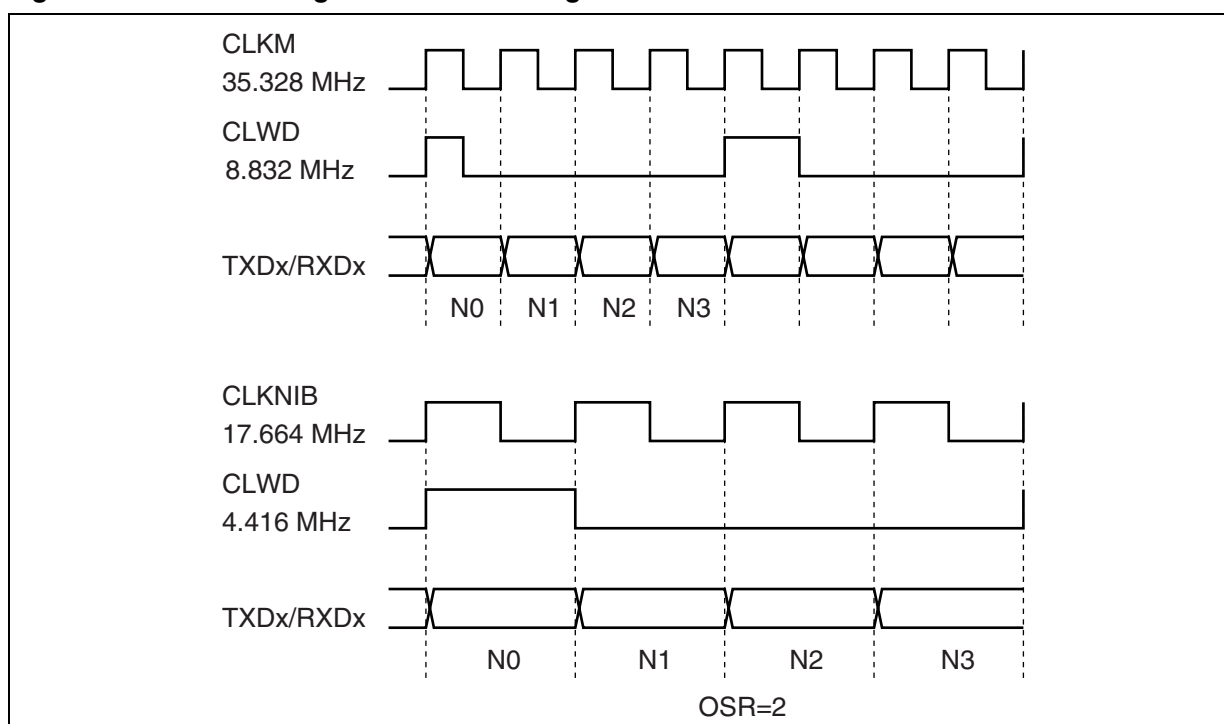

Power Down

The MTC20154 is placed in power-down mode when the PD pin is high. The system specifications are requiring different behavior of the MTC20154 under power down mode according to the fact that the MTC20154 is used at the LT or the NT side. The chip status is depicted in the following table:

Table 23. Power Down

Power down LT side	Power down NT side
CLKM pin is replicating the XTALO input clock (no crystal used at LT side). System clock available CLKWD is generated. Digital blocks active Analog TX path is in powerdown External driver is forced to power UP	Crystal driver + VCODAC are active CLKWD is generated. Digital blocks active, except for RX-I/O's – they are at low level Analog RX & TX are in powerdown External driver is forced to power DOWN

Reset Function

The MTC20154 is placed in reset mode when the RESETN pin is pulled to ground (active low signal). The system specifications are requiring different behavior of the MTC20154 under reset mode according to the fact that the MTC20154 is used at the LT or the NT side. The chip status is depicted in the following table:

Table 24. Reset Function (N.B. The reset signal is dominant over the powerdown signal.)

Reset LT side CLKM pin is replicating the XTALO input clock (no crystal used at LT side). System clock available CLKWD is not generated. The pin stays at high level. Digital blocks are in reset: no activity Analog blocks are in powerdown External driver is forced to powerdown	Reset NT side Crystal driver in power down: no CLKM signal available. No system clock avail-able. CLKWD is not generated. The pin stays at high level Digital blocks are in reset: no activity Analog blocks are in powerdown External driver is forced to powerdown
--	--

MTC20154

DIM.	mm			inch		
	MIN.	TYP.	MAX.	MIN.	TYP.	MAX.
A			1.60			0.063
A1	0.05		0.15	0.002		0.006
A2	1.35	1.40	1.45	0.053	0.055	0.057
B	0.17	0.22	0.27	0.0066	0.0086	0.0086
C	0.09			0.0035		
D	11.80	12.00	12.20	0.464	0.472	0.480
D1	9.80	10.00	10.20	0.386	0.394	0.401
D3		7.50			0.295	
e		0.50			0.0197	
E	11.80	12.00	12.20	0.464	0.472	0.480
E1	9.80	10.00	10.20	0.386	0.394	0.401
E3		7.50			0.295	
L	0.45	0.60	0.75	0.0177	0.0236	0.0295
L1		1.00			0.0393	
K	0° (min.), 3.5° (min.), 7° (max.)					
ccc			0.080			0.0031

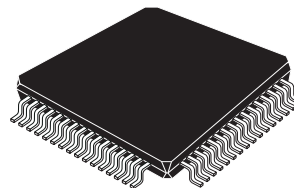
OUTLINE AND MECHANICAL DATA**TQFP64 (10 x 10 x 1.4mm)**

et4U.com

DataShee

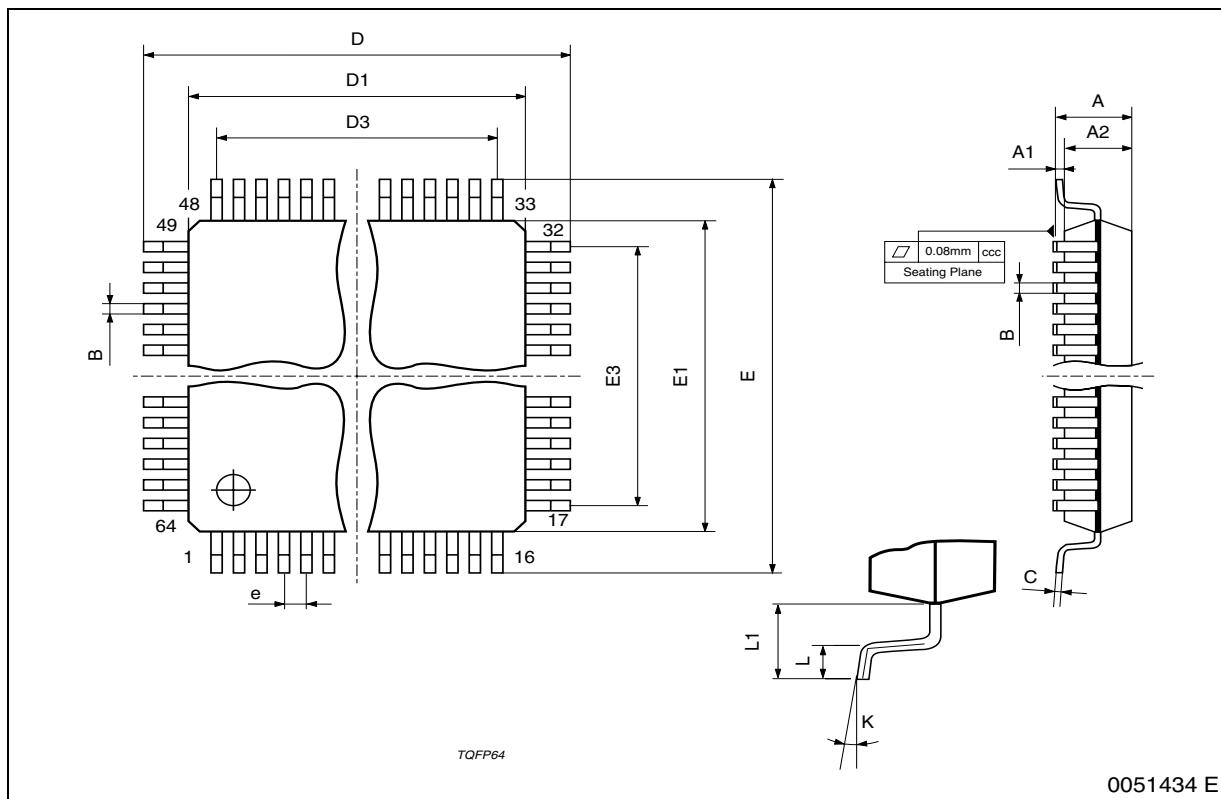

et4U.com

DataSheet4U.com

Information furnished is believed to be accurate and reliable. However, STMicroelectronics assumes no responsibility for the consequences of use of such information nor for any infringement of patents or other rights of third parties which may result from its use. No license is granted by implication or otherwise under any patent or patent rights of STMicroelectronics. Specifications mentioned in this publication are subject to change without notice. This publication supersedes and replaces all information previously supplied. STMicroelectronics products are not authorized for use as critical components in life support devices or systems without express written approval of STMicroelectronics.

The ST logo is a registered trademark of STMicroelectronics.
All other names are the property of their respective owners

© 2004 STMicroelectronics - All rights reserved

STMicroelectronics GROUP OF COMPANIES

Australia - Belgium - Brazil - Canada - China - Czech Republic - Finland - France - Germany - Hong Kong - India - Israel - Italy - Japan -
Malaysia - Malta - Morocco - Singapore - Spain - Sweden - Switzerland - United Kingdom - United States

www.st.com

