

MTCVO31 Series Temperature Compensated Voltage Controlled Crystal Oscillators (TCVCXO)



Features:

- 14 Pin DIP Compatible
- Tight Stability Over Wide Temperature
- Voltage Control

Applications

- PCS, Cellular Equipment
- Communications Equipment
- Portable Equipment

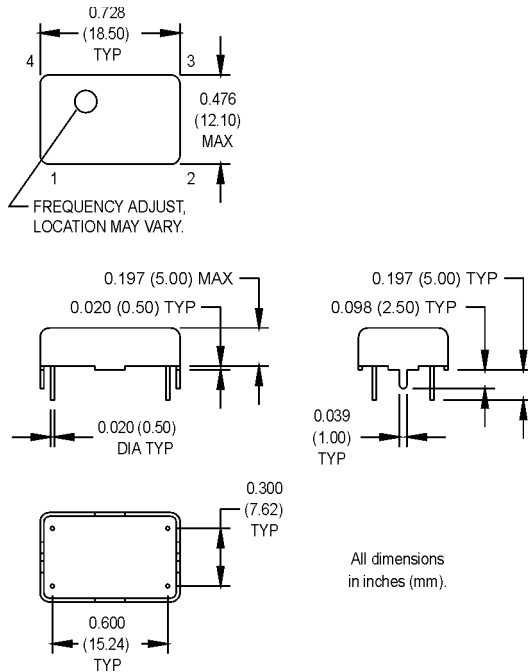

Electrical Specifications

PARAMETERS	VALUE
Frequency Range	9.600 to 32.000 MHz
Stability	±2.5 ppm
Stability with ±5% Vcc Change	±0.3 ppm
Aging	±1 ppm/yr. Max.
Operating Temperature	-30°C to +75°C
Storage Temperature	-40°C to +85°C
Output (Clipped Sinewave)	1.0 V p-p Min.
Output Load	10K Ω 10 pF
Frequency Adjustment (Int. Trimmer)	±3 ppm Min.
Control Range	±8 ppm to ±15 ppm
Control Voltage	2.5 V ±2.0 V
Supply Voltage	+5.0 V ±5%
Supply Current	2 mA Max.

See page 112 for suggested soldering conditions.

Pin Connections

PIN	FUNCTION
1	Control Voltage
2	Circuit/Case Ground
3	Output
4	+Vcc