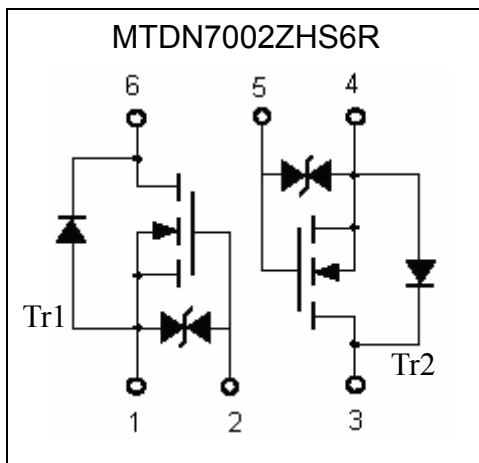
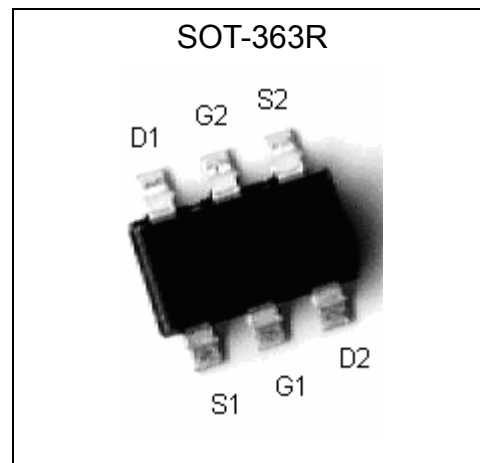

N-CHANNEL MOSFET (dual transistors)

MTDN7002ZHS6R

Features

- Low on-resistance
- High ESD capability
- High speed switching
- Low-voltage drive(4V)
- Easily designed drive circuits
- Easy to use in parallel
- Pb-free package

Equivalent Circuit

Outline

The following characteristics apply to both Tr1 and Tr2

Absolute Maximum Ratings (Ta=25°C)

Parameter	Symbol	Limits	Unit
Drain-Source Voltage	V _{DSS}	60	V
Gate-Source Voltage	V _{GSS}	±20	V
Drain Current	Continuous	I _D	115 mA
	Pulsed	I _{DP}	700 (Note 1) mA
Drain Reverse Current	Continuous	I _{DR}	115 mA
	Pulsed	I _{DRP}	700 (Note 1) mA
Power Dissipation	P _d	300(total) (Note 2)	mW
ESD susceptibility		1250 (Note 3)	V
Junction Temperature	T _j	150	°C
Storage Temperature	T _{stg}	-55~+150	°C

Note : 1. Pulse test, pulse width ≤ 300μs, duty ≤ 2%
 2. 200mW per element must not be exceeded.
 3. Human body model, 1.5kΩ in series with 100pF

**Electrical Characteristics (Ta=25°C)**

Symbol	Min.	Typ.	Max.	Unit	Test Conditions
BV_{DSS}^*	60	-	-	V	$V_{GS}=0, I_D=10\mu A$
$V_{GS(th)}$	1	-	2.5	V	$V_{DS}=V_{GS}, I_D=250\mu A$
I_{GSS}	-	-	± 10	μA	$V_{GS}=\pm 20V, V_{DS}=0$
I_{DSS}	-	-	1	μA	$V_{DS}=60V, V_{GS}=0$
$R_{DS(ON)}^*$	-	3.6	5.5	Ω	$I_D=100mA, V_{GS}=5V$
	-	3	5		$I_D=100mA, V_{GS}=10V$
G_{FS}	100	-	-	mS	$V_{DS}=10V, I_D=100mA$
C_{iss}	-	7.32	-	pF	$V_{DS}=10V, V_{GS}=0, f=1MHz$
C_{oss}	-	3.42	-		
C_{rss}	-	7.63	-		

*Pulse Test : Pulse Width $\leq 300\mu s$, Duty Cycle $\leq 2\%$ **Ordering Information**

Device	Package	Shipping	Marking
MTDN7002ZHS6R	SOT-363 (Pb-free)	3000 pcs / Tape & Reel	72

Characteristic Curves

Typical Output Characteristics

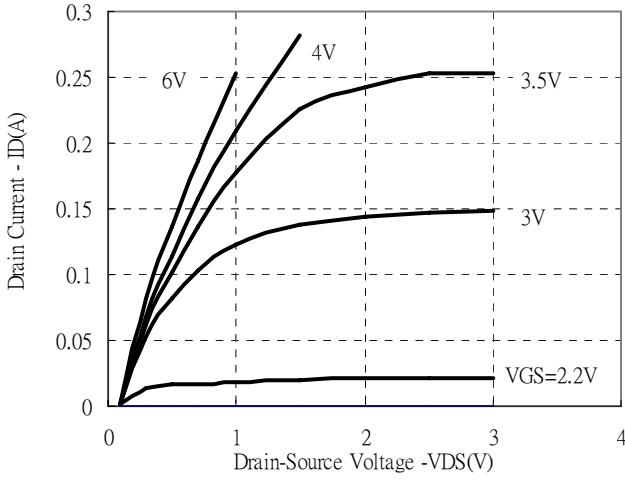

Typical Transfer Characteristics

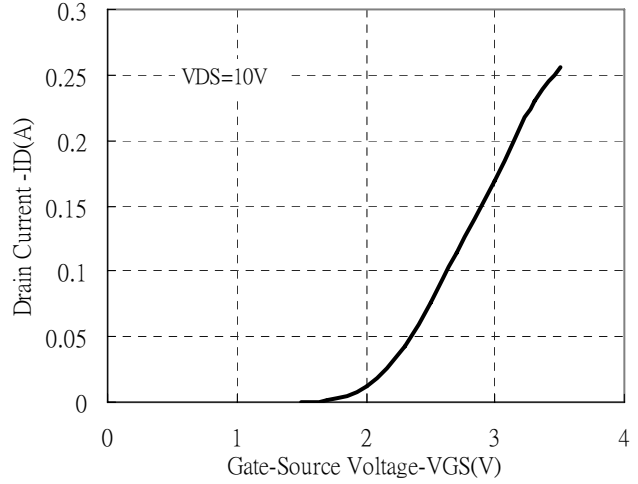

Static Drain-Source On-State resistance vs Drain Current

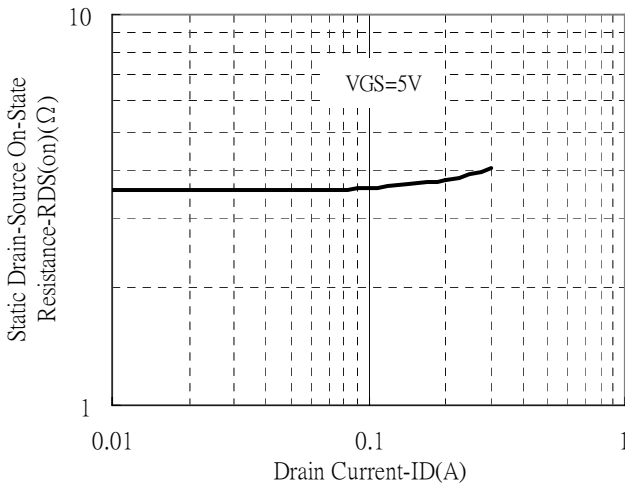

Static Drain-Source On-State resistance vs Drain Current

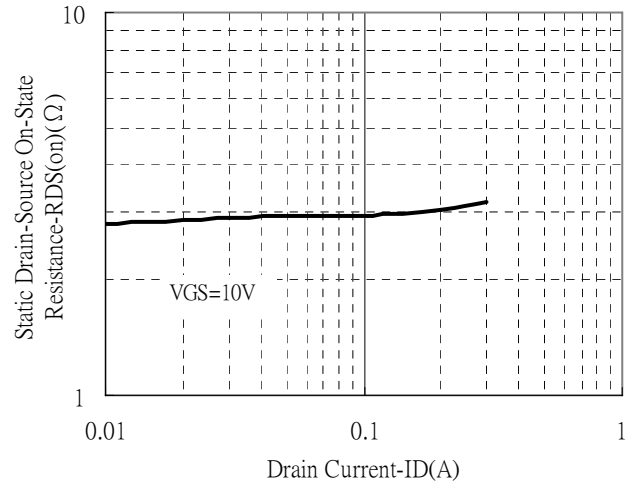

Static Drain-Source On-State Resistance vs Gate-Source Voltage

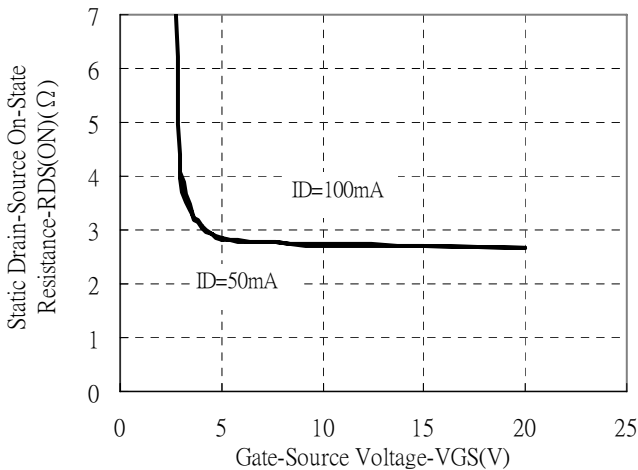

Reverse Drain Current vs Source-Drain Voltage

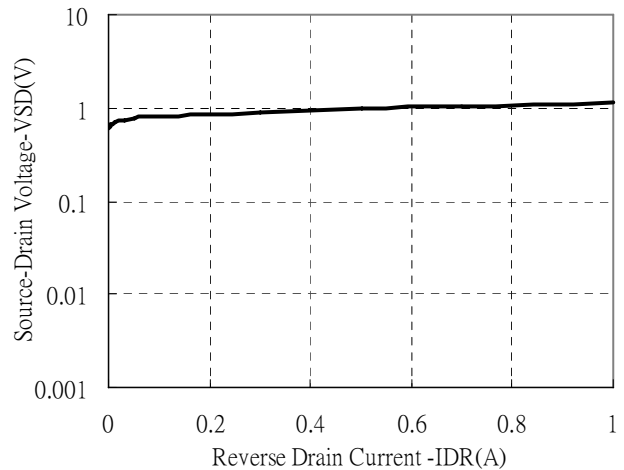



Capacitance vs Drain-to-Source Voltage

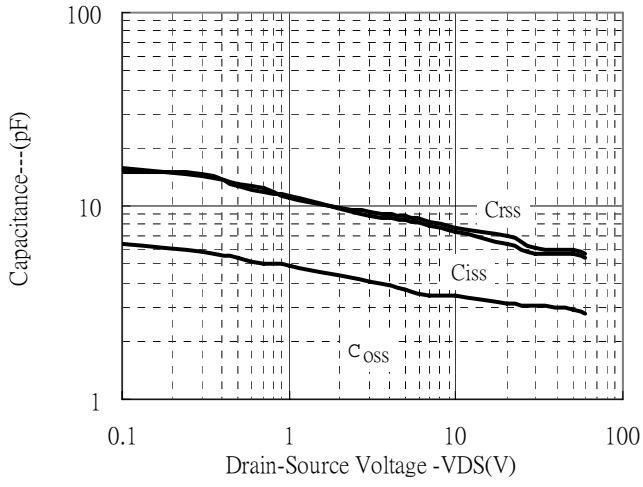

Power Derating Curves

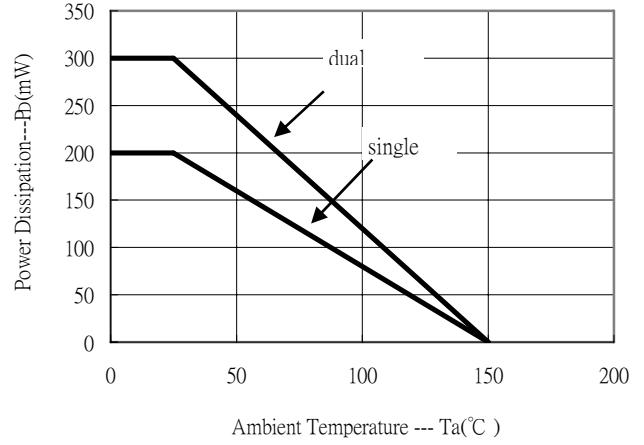

Reel Dimension

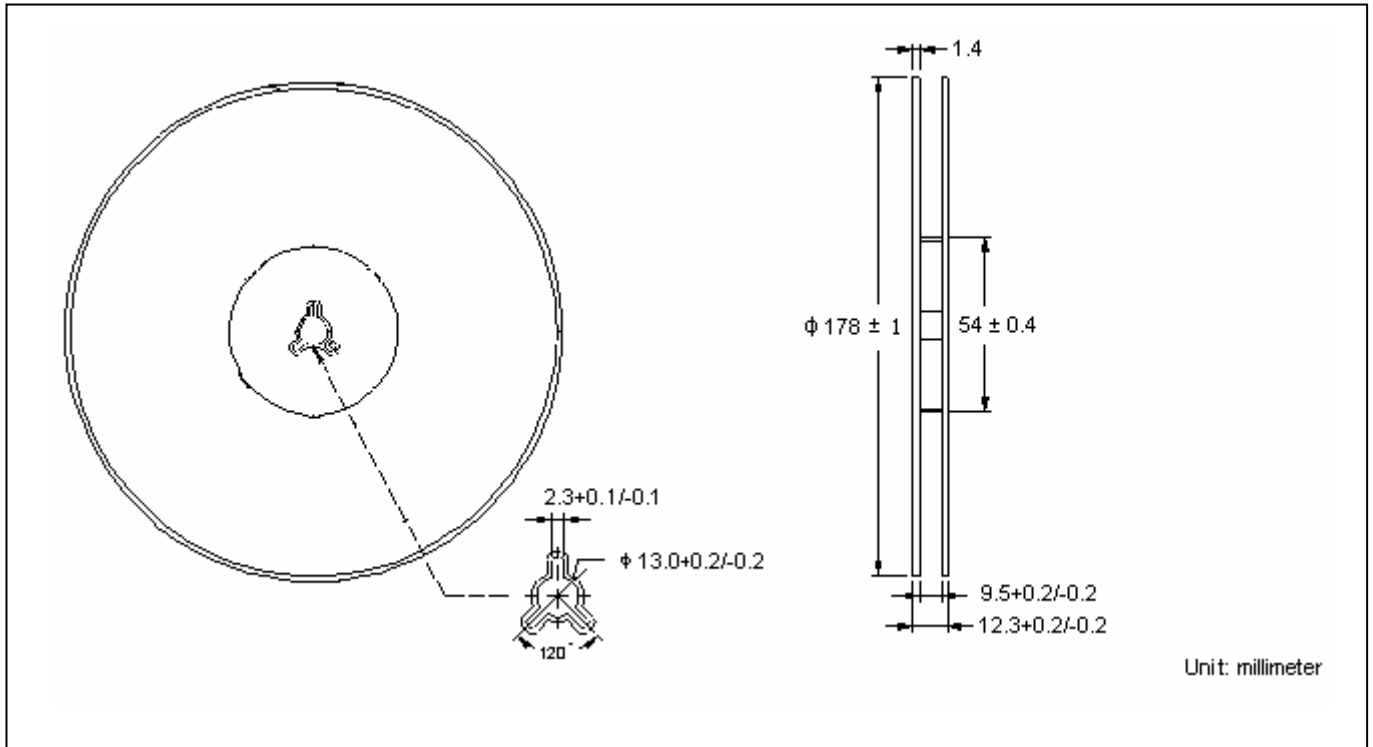

Carrier Tape Dimension

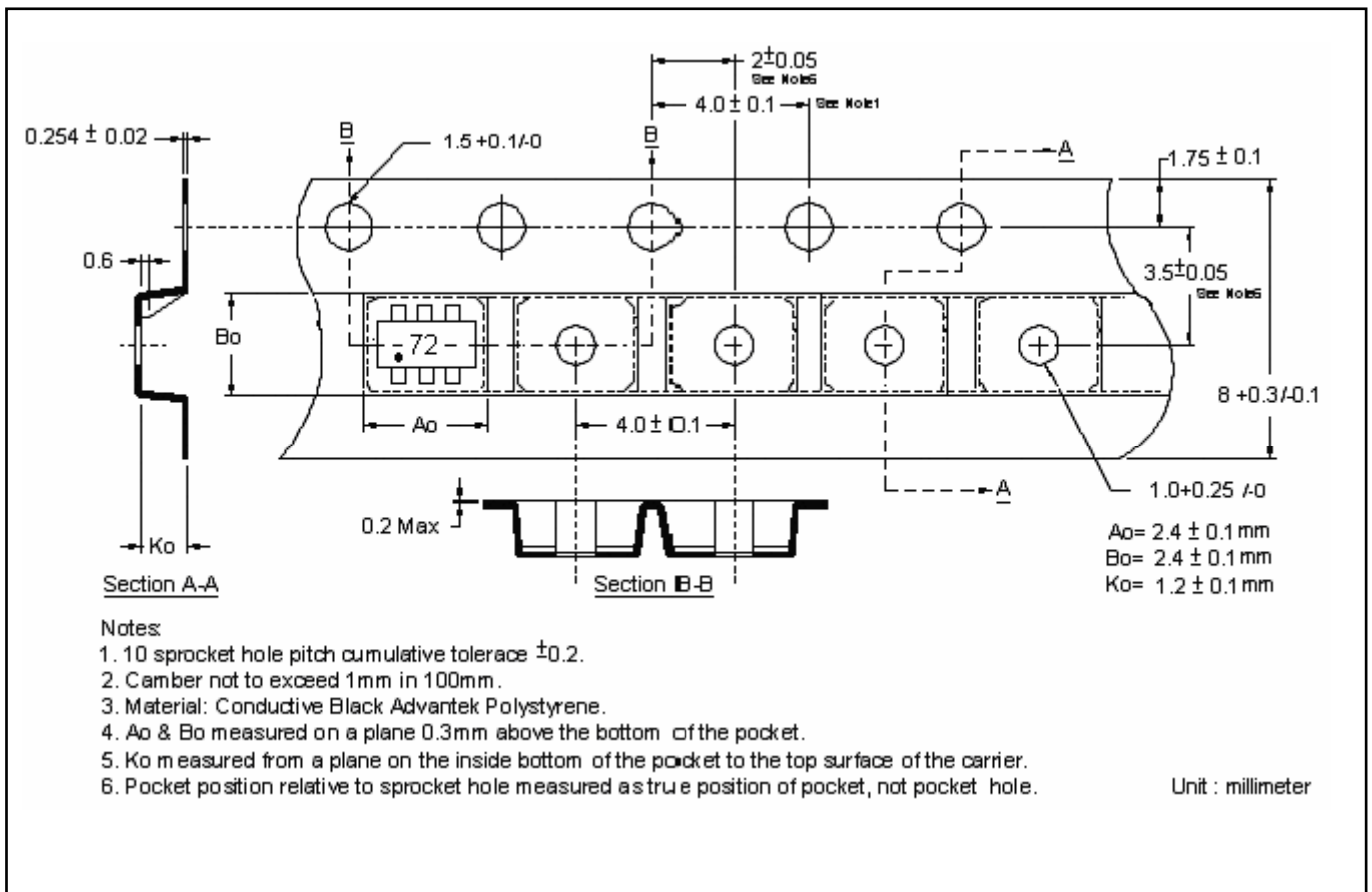

SOT-363R Dimension

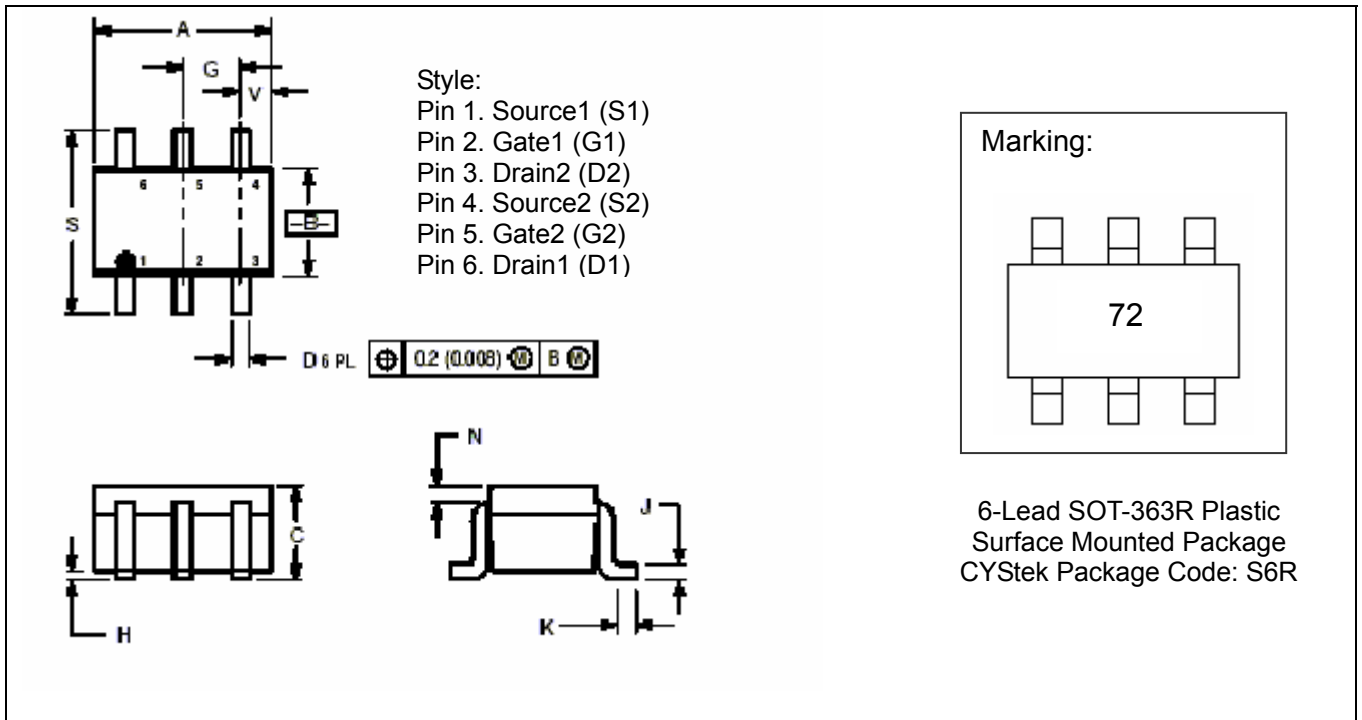

*:Typical

DIM	Inches		Millimeters		DIM	Inches		Millimeters	
	Min.	Max.	Min.	Max.		Min.	Max.	Min.	Max.
A	0.071	0.087	1.8	2.2	J	0.004	0.010	0.1	0.25
B	0.045	0.053	1.15	1.35	K	0.004	0.012	0.1	0.30
C	0.031	0.043	0.8	1.1	N	0.008 REF		0.20 REF	
D	0.004	0.012	0.1	0.3	S	0.079	0.087	2.00	2.40
G	0.026BSC		0.65BSC		Y	0.012	0.016	0.30	0.40
H	-	0.004	-	0.1					

- Notes : 1.Controlling dimension : millimeters.
 2.Maximum lead thickness includes lead finish thickness, and minimum lead thickness is the minimum thickness of base material.
 3.If there is any question with packing specification or packing method, please contact your local CYStek sales office.

Material :

- Lead : 42 Alloy ; solder plating
- Mold Compound : Epoxy resin family, flammability solid burning class:UL94V-0

Recommended wave soldering condition

Product	Peak Temperature	Soldering Time
Pb-free devices	260 +0/-5 °C	5 +1/-1 seconds

Recommended temperature profile for IR reflow

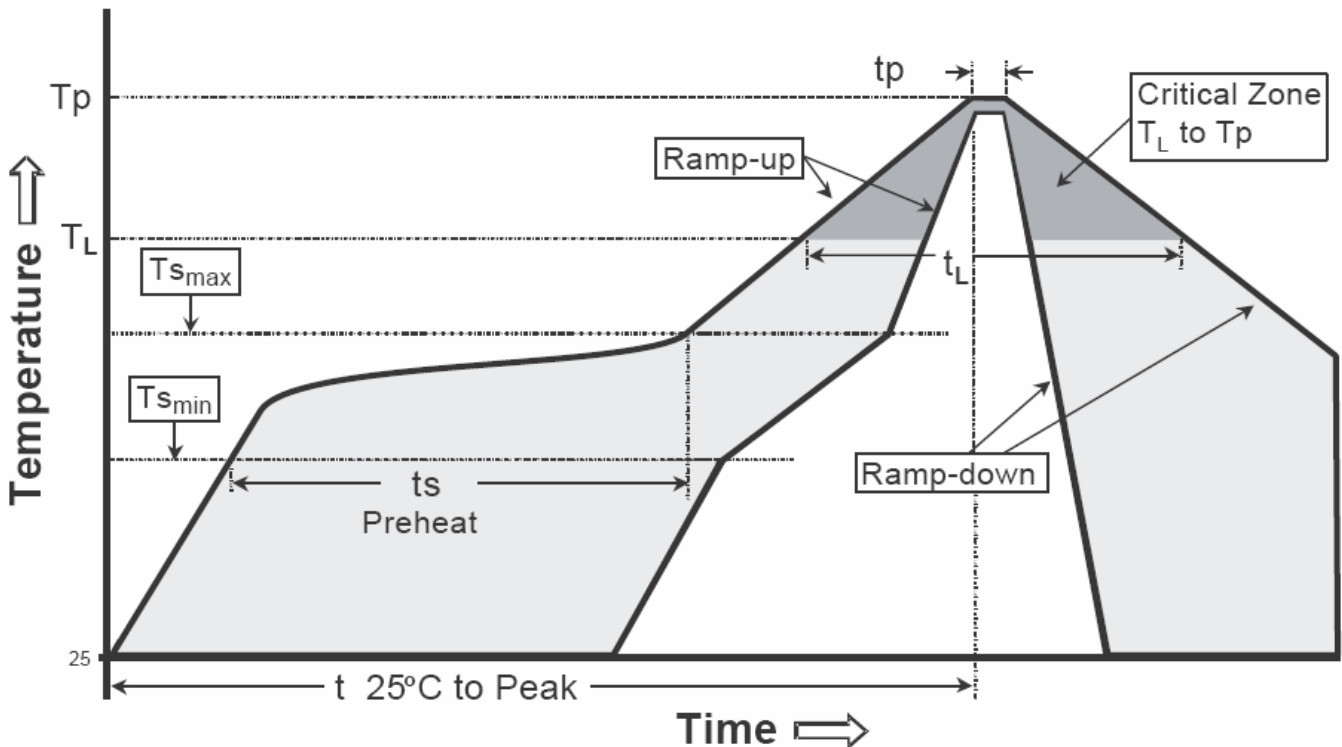

Profile feature	Sn-Pb eutectic Assembly	Pb-free Assembly
Average ramp-up rate (T _{smax} to T _p)	3°C/second max.	3°C/second max.
Preheat		
-Temperature Min(T _{s min})	100°C	150°C
-Temperature Max(T _{s max})	150°C	200°C
-Time(t _{s min} to t _{s max})	60-120 seconds	60-180 seconds
Time maintained above:		
-Temperature (T _L)	183°C	217°C
- Time (t _L)	60-150 seconds	60-150 seconds
Peak Temperature(T _p)	240 +0/-5 °C	260 +0/-5 °C
Time within 5°C of actual peak temperature(tp)	10-30 seconds	20-40 seconds
Ramp down rate	6°C/second max.	6°C/second max.
Time 25 °C to peak temperature	6 minutes max.	8 minutes max.

Note : All temperatures refer to topside of the package, measured on the package body surface.

Important Notice:

- All rights are reserved. Reproduction in whole or in part is prohibited without the prior written approval of CYStek.
- CYStek reserves the right to make changes to its products without notice.
- CYStek **semiconductor products are not warranted to be suitable for use in Life-Support Applications, or systems.**
- CYStek assumes no liability for any consequence of customer product design, infringement of patents, or application assistance.