

GENERAL SPECIFICATION

Item	Content
Number of Character	128x64
Module Size	75.0(W)x52.7(H)x6.8/9.0(D)mm Max
Viewing Area	60.0(W)x32.5(H)mm
Dot Size/Dot Pitch	0.40(W)x0.40(H)mm/0.43(W)x0.43(H)mm
Backlight	Without/EL/LED
Options	Gray STN/Yellow STN/Normal/Extended Temperature/Bottom/Top Viewing
Built-in Controller	KS0108 or compatible

INTERFACE PIN ASSIGNMENT

Pin No.	Pin Out	Function Description
1	V _{DD}	Logic supply voltage
2	V _{SS}	GND
3	V _{ADJ}	Supply voltage for LCD panel, TUNING FROM V _{DD} -V _{EE}
4-11	DB0-DB7	Data Bus: 3-state I/O common terminal.
12	CS1	Chip select for the left half of the display. Active high
13	CS2	Chip select for the right half of the display. Active high
14	RES	Setting the RES signal to Low level can initialize the following registers. 1. ON/OFF register 0 set (Display off) 2. Display start line register 0 set (display starts from line 0). After releasing reset, this condition can be changed only by software.
15	R/W	Read/Write R/W=high: Data of DB0-DB7 can be read by CPU. R/W=low: Data of DB0-DB7 can be written into LCD driver IC at the falling edge of E when CS1 and CS2 is high
16	D/I	Data/Instruction D/I=high: Indicates that data of DB0-DB7 is display data. D/I=low: Indicates that data of DB0-DB7 is instruction.
17	E	Enable: When write (R/W=low): Data of DB0-DB7 is latched at the fall of E. When read(R/W=high): Data is read while E is at high level.
18	V _{EE}	Supply voltage for LCD panel. Please refer page 11 for DC to DC connection
19	BKL _A	Power supply for backlight. (4.2V/100-150mA DC for LED backlight, 110V/400Hz AC for EL)
20	BKL _K	

ELECTRICAL CHARACTERISTICS

Item	Symbol	Condition	Min.	Typ	Max.	Unit	note		
Power Supply for Logic	V _{DD} -V _{SS}	-	4.5	5.0	5.5	Volt	-		
Input Voltage	V _{IL} V _{IH}	L level H level	V _{SS} 0.8V _{DD}	0.2V _{DD} V _{DD}	-				
LCM Recommend LCD Module Driving Voltage	V _{DD} -V _{ADJ}	Ta=-20°C Ta=25°C Ta=70°C	10.1 9.7 9.6	10.7 10.3 10.2	11.3 10.9 10.8	Volt	-		
Power Supply Current for LCM	I _{DD} (LED B/L OFF) I _{LED} (LED B/L ON)	V _{DD} =5.0V Ta=25°C	- -	1.5 100	1.8 150			mA	-
Power Supply for LED Backlight	I _{EE} V _{LED}	V _{DD} -V _{ADJ} =10.3V V _{LEDA} -V _{LEDK} =4.2V	- -	0.6 4.2	1.0 -				

BLOCK DIAGRAM

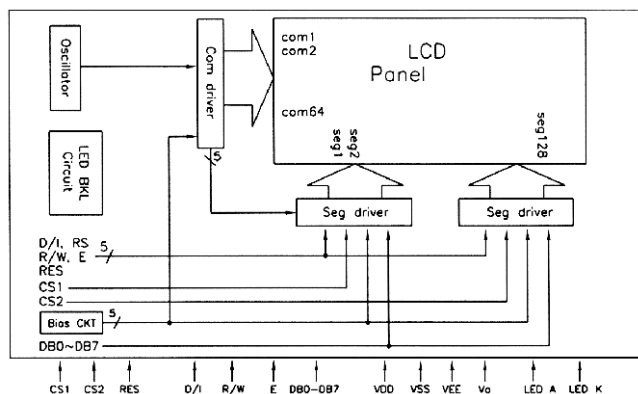

POWER SUPPLY

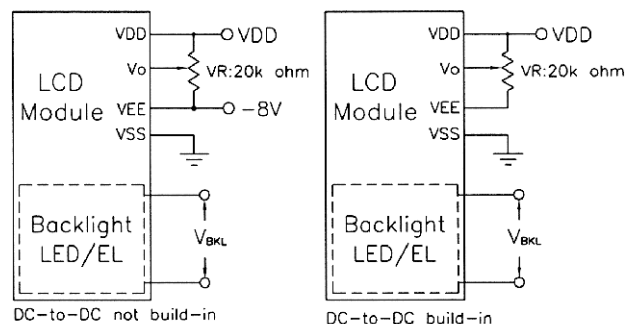

MECHANICAL

