

# MUR2020CT/FCT/DC

## ULTRAFAST RECOVERY RECTIFIERS

**VOLTAGE** 200 Volt **CURRENT** 20 Ampere

### FEATURES

- Plastic package has Underwriters Laboratory Flammability Classification 94V-O. Flame Retardant Epoxy Molding Compound.
- Low power loss, high efficiency.
- High current capability
- For use in low voltage, high frequency inverters free wheeling, and polarity protection applications.
- Lead free in compliance with EU RoHS 2011/65/EU directive

### MECHANICAL DATA

Device Weight : 0.07 ounces (1.96grams) - TO -220AB  
 0.06 ounces (1.74grams) - ITO 220AB  
 0.04 ounces (1.16 grams) - TO -263

- Terminals: solder plated, solderable per MIL-STD-750, Method 2026
- Polarity: As marked.

Mounting Torque : Recommended 4~5 kg-cm.

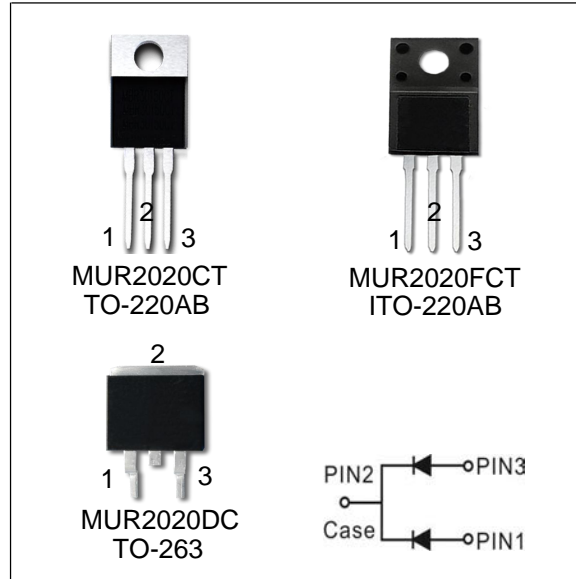

MARK: BMXXX

### MAXIMUM RATINGS( $T_A=25^{\circ}\text{C}$ unless otherwise noted)

PARAMETER	SYMBOL	VALUE	UNIT
Maximum repetitive peak reverse voltage	$V_{RRM}$	200	V
Maximum average forward rectified current	$I_{F(AV)}$	10 20	A
Peak forward surge current 8.3ms single half sine-wave superimposed on rated load	$I_{FSM}$	125	A
Typical junction capacitance ( $V_R=4V$ , $f=1\text{MHz}$ )	$C_J$	170	pF
Typical thermal resistance per diode (Note 1)	$R_{\theta JC}$	2.0	$^{\circ}\text{C/W}$
Maximum Reverse Recovery Time (Note 2)	$T_{rr}$	35	ns
Operating junction temperature range	$T_J$	-40 to + 150	$^{\circ}\text{C}$
Storage temperature range	$T_{STG}$	-40 to + 150	$^{\circ}\text{C}$

Note : 1. Mounted on infinite heatsink.

### ELECTRICAL CHARACTERISTICS( $T_A=25^{\circ}\text{C}$ unless otherwise noted)

PARAMETER	SYMBOL	TEST CONDITIONS	MIN.	TYP.	MAX.	UNIT
Breakdown voltage per diode	$V_{BR}$	$I_R=0.1\text{mA}$	200	-	-	V
Instantaneous forward voltage per diode	$V_F$	$I_F=10\text{A}$ $T_J=25^{\circ}\text{C}$	-	-	0.975	V
Reverse current per diode	$I_R$	$V_R=200\text{V}$ $T_J=25^{\circ}\text{C}$	-	-	1	$\mu\text{A}$

# MUR2020CT/FCT/DC

## RATING AND CHARACTERISTIC CURVES

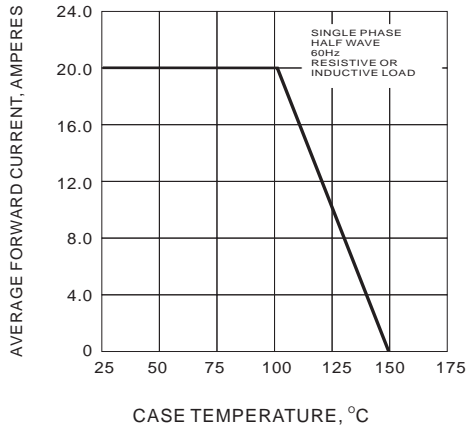

Fig. 1 FORWARD CURRENT DERATING CURVE

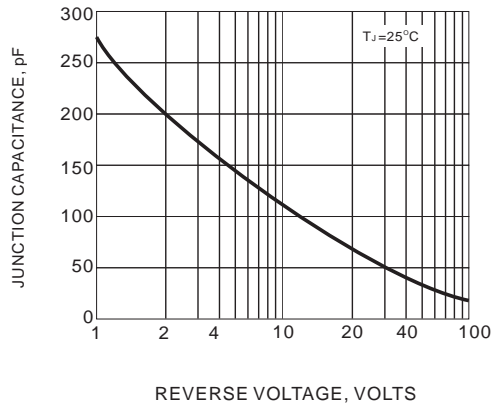

Fig. 2 TYPICAL JUNCTION CAPACITANCES

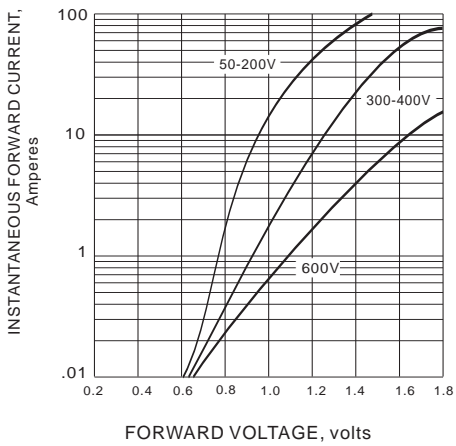

Fig. 3 FORWARD CHARACTERISTICS

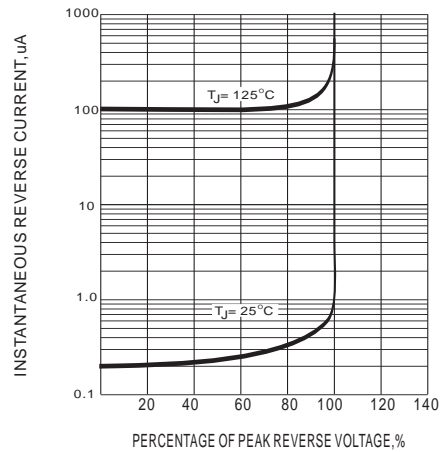

Fig. 4 TYPICAL REVERSE CHARACTERISTICS

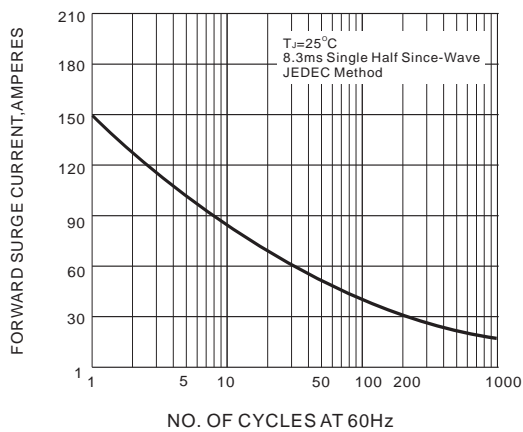
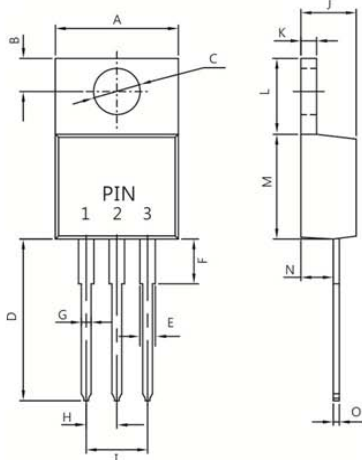

Fig. 5 PEAK FORWARD SURGE CURRENT

# MUR2020CT/FCT/DC

**TO-220AB**

Dim.	Min.	Max.
A	----	10.50
B	2.50	3.50
C	3.50	4.10
D	13.10	13.90
E	1.15	1.49
F	----	6.35
G	0.65	0.95
H	2.29	2.79
I	4.80	5.30
J	4.40	4.80
K	1.14	1.40
L	5.84	6.86
M	8.50	9.60
N	2.03	2.92
O	0.30	0.64

All Dimensions in millimeter

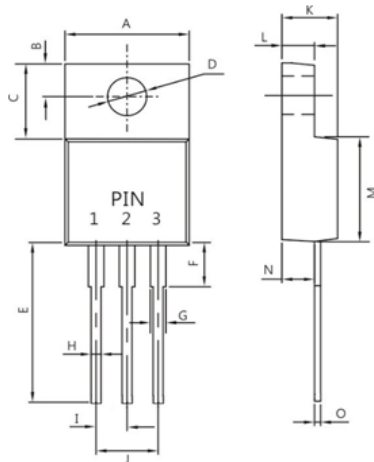
**ITO-220AB**

Dim.	Min.	Max.
A	----	10.50
B	2.60	3.00
C	6.70	7.10
D	2.90	3.50
E	13.10	13.90
F	----	4.00
G	1.11	1.45
H	0.40	0.80
I	2.40	2.80
J	5.00	5.40
K	4.30	4.70
L	2.90	3.30
M	8.20	9.00
N	2.50	2.90
O	0.40	0.80

All Dimensions in millimeter

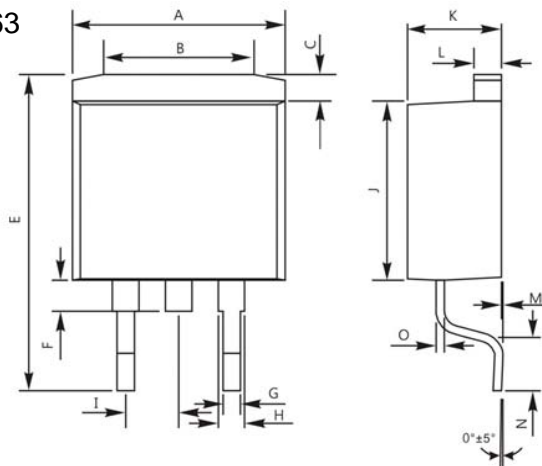
**TO-263**

Dim.	Min.	Max.
A	9.65	10.69
B	7.30	Ref.
C	1.30	Ref.
E	14.70	15.90
F	1.5	Ref.
G	0.76	1.00
H	1.14	1.70
I	2.54	Ref.
J	8.55	9.50
K	4.40	4.85
L	1.25	1.50
M	----	0.25
N	2.30	2.80
O	0.36	0.60

All Dimensions in millimeter