

文件名称	BLU Purchase Specification 模组规格书	页次	1 / 13
产品名称	18 . 5寸 - 2 T 模组规格书	版次	1.1

规格书

Specification Sheet

客户 :
(Customer Name) _____

品名:
(Material Name) _____

料号:
(Material Number) _____

料号:
(Customer Material Number) _____

客户承认			
Customer			
<i>Approved by</i> 承认	<i>Checked by</i> 审核	<i>Approved by</i> 承认	
		<i>Checked by</i> 审核	
		<i>Designed by</i> 编写	

--	--

TITLE : MV185WHB-N10
Preliminary Product Specification
Rev. P0

SPEC. NUMBER S	PRODUCT GROUP TFT-LCD	Rev.P0	ISSUE DATE 2015.05.29	P 1
-------------------	--------------------------	--------	--------------------------	--------

	PRODUCT GROUP	REV	ISSUE DATE
	TFT- LCD PRODUCT	Rev.P0	May.29,15'

1.0 GENERAL DESCRIPTION

1.1 Introduction

MV185WHB-N10 is a color active matrix TFT LCD module using amorphous silicon TFT's (Thin Film Transistors) as an active switching devices. This module has a 18.5 inch diagonally measured active area with WXGA resolutions (1366 horizontal by 768 vertical pixel array). Each pixel is divided into RED, GREEN, BLUE dots which are arranged in vertical stripe and this module can display 16.7M colors. The TFT-LCD panel used for this module is adapted for a low reflection and higher color type.

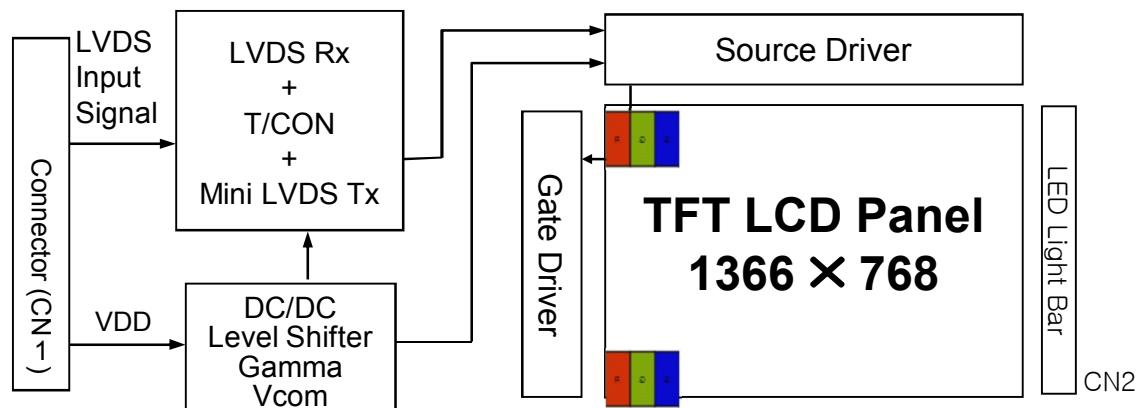

1.2 Features

- LVDS Interface with 1 pixel / clock
- High-speed response
- 6-bit (Hi-FRC) color depth, display 16. 7M colors
- High luminance and contrast ratio, low reflection and normal viewing angle
- DE (Data Enable) only
- RoHS
- Gamma Correction
- Forward Type

SPEC. NUMBER	SPEC. TITLE	P
S	MV185WHB-N10 Preliminary Product Specification Rev. P0	4

	PRODUCT GROUP	REV	ISSUE DATE
	TFT- LCD PRODUCT	Rev.P0	May.29,15'

1.3 Application

- Desktop Type of PC & Workstation Use
- Slim-Size Display for Stand-alone Monitor
- Display Terminals for Control System
- Monitors for Process Controller

1.4 General Specification

The followings are general specifications at the open cell MV185WHB-N10.

<Table 1. General Specifications>

Parameter	Specification	Unit	Remarks
Active area	409.8(H) × 230.4(V)	mm	
Number of pixels	1366(H) × 768(V)	pixels	
Pixel pitch	0.3(H) × 0.3(V)	mm	
Pixel arrangement	RGB Vertical stripe		
Display colors	16.7M	colors	
Display mode	Normally Black		
Weight	TBD(typ.)	g	
Surface Treatment	Haze 25%, 3H		

SPEC. NUMBER S	SPEC. TITLE MV185WHB-N10 Preliminary Product Specification Rev. P0	P 5
-------------------	---	--------

	PRODUCT GROUP	REV	ISSUE DATE
	TFT- LCD PRODUCT	Rev.P0	May.29,15'

2.0 ABSOLUTE MAXIMUM RATINGS

The followings are maximum values which, if exceed, may cause faulty operation or damage to the unit. The operational and non-operational maximum voltage and current values are listed in Table 2.

< Table 2. Absolute Maximum Ratings >

[VSS=GND=0V]

Parameter	Symbol	Min.	Max.	Unit	Remarks
Power Supply Voltage	V_{DD}	-0.3	7	V	Ta = 25 °C
Logic Supply Voltage	V_{IN}	VSS-0.3	$V_{DD}+0.3$	V	
Operating Temperature	T_{OP}	0	+50	°C	1)
Storage Temperature	T_{ST}	-20	+60	°C	1)

Note : 1) Temperature and relative humidity range are shown in the figure below.
Wet bulb temperature should be 39 °C max. and no condensation of water.

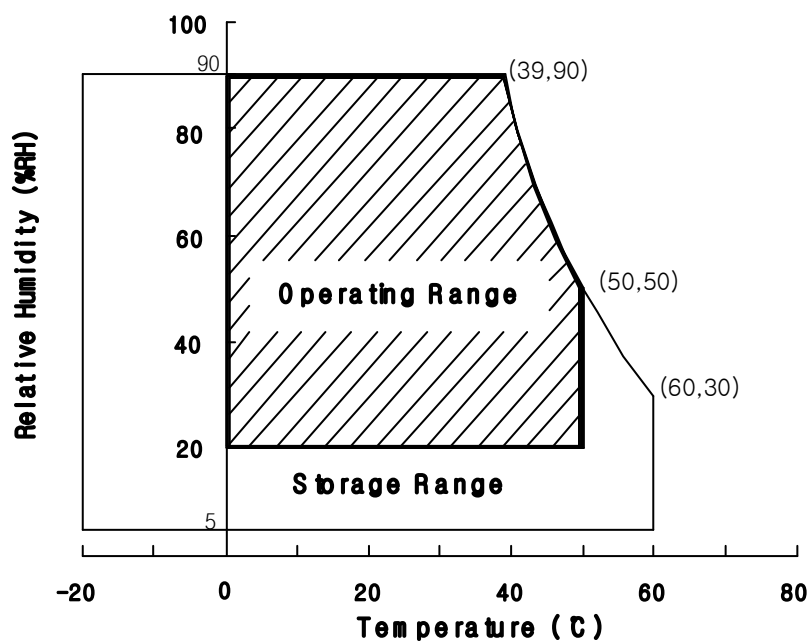

SPEC. NUMBER S	SPEC. TITLE MV185WHB-N10 Preliminary Product Specification Rev. P0	P 6
-------------------	---	--------

	PRODUCT GROUP	REV	ISSUE DATE
	TFT- LCD PRODUCT	Rev.P0	May.29,15'

3.0 ELECTRICAL SPECIFICATIONS

3.1 Electrical Specifications

< Table 3. Electrical specifications >

[Ta =25 ±2 °C]

Parameter		Min.	Typ.	Max.	Unit	Remarks
Power Supply Voltage	V _{DD}	4.5	5.0	5.5	V	Note1
Power Supply Current	I _{DD}	-	900	1100	mA	
In-Rush Current	I _{RUSH}	-	2	3	A	Note 2
Permissible Input Ripple Voltage	V _{RF}	-	-	300	mV	V _{DD} = 5.0V
High Level Differential Input Threshold Voltage	V _{IH}	-	-	+100	mV	
Low Level Differential Input Threshold Voltage	V _{IL}	-100	-	-	mV	
Differential input voltage	V _{ID}	200	-	600	mV	
Differential input common mode voltage	V _{cm}	1.0	1.2	1.5		V _{IH} =100mV, V _{IL} =-100mV
Power Consumption	P _D	-	4.5	5.5	W	@60Hz

- Notes :
1. The supply voltage is measured and specified at the interface connector of LCM.
The current draw and power consumption specified is for VDD=5.0V, Frame rate=60Hz and Clock frequency = 75.4MHz. Test Pattern of power supply current
 - a) Typ : Color Bar pattern
 - b) Max : Gray Level 255
 2. Duration of rush current is about 2 ms and rising time of VDD is 520 μs ± 20 %

SPEC. NUMBER S	SPEC. TITLE MV185WHB-N10 Preliminary Product Specification Rev. P0	P 7
-------------------	---	--------

	PRODUCT GROUP	REV	ISSUE DATE
	TFT- LCD PRODUCT	Rev.P0	May.29,15'

4.0 OPTICAL SPECIFICATION

4.1 Overview

The test of Optical specifications shall be measured in a dark room (ambient luminance = 1 lux and temperature = 25±2°C) with the equipment of Luminance meter system (Goniometer system and TOPCONE PR730) and test unit shall be located at an approximate distance 50cm from the LCD surface at a viewing angle of θ and Φ equal to 0°. We refer to $\theta_{\theta=0}$ (= θ_3) as the 3 o'clock direction (the "right"), $\theta_{\theta=90}$ (= θ_{12}) as the 12 o'clock direction ("upward"), $\theta_{\theta=180}$ (= θ_9) as the 9 o'clock direction ("left") and $\theta_{\theta=270}$ (= θ_6) as the 6 o'clock direction ("bottom"). While scanning θ and/or Φ , the center of the measuring spot on the Display surface shall stay fixed. The measurement shall be executed after 30 minutes warm-up period. VDD shall be 5.0V +/-10% at 25°C. Optimum viewing angle direction is 6 o'clock.

4.2 Optical Specifications

[VDD = 5.0V, Frame rate = 60Hz, Clock = 75.4MHz, I_{BL} = 340mA, Ta = 25 ± 2 °C]

Parameter		Symbol	Condition	Min.	Typ.	Max.	Unit	Remark
Viewing Angle range	Horizontal	θ_3	CR > 10	85	89	-	Deg.	Note 2
		θ_9		85	89	-	Deg.	
	Vertical	θ_{12}		85	89	-	Deg.	
		θ_6		85	89	-	Deg.	
Luminance Contrast ratio		CR	$\theta = 0^\circ$ (Center) Normal Viewing Angle	700	1000	-		Note 3
Cell Transmittance		Tr		-	5.1	-	%	Note 4
White luminance uniformity		ΔY		75	80	-	%	Note 5
Reproduction of color	White	W_x		0.283	0.313	0.343	-	Note 6
		W_y		0.299	0.329	0.359		
	Red	R_x			TBD			
		R_y			TBD			
	Green	G_x			TBD			
		G_y		TBD				
	Blue	B_x		TBD				
		B_y		TBD				
Response Time	GTG	T_r	-	TBD		ms	Note 7	
Cross Talk		CT		-	-	2.0	%	Note 8

SPEC. NUMBER S	SPEC. TITLE MV185WHB-N10 Preliminary Product Specification Rev. P0	P 8
-------------------	---	--------

	PRODUCT GROUP	REV	ISSUE DATE
	TFT- LCD PRODUCT	Rev.P0	May.29,15'

Note :

1. The value in upper table are based on BLU provided by BOEDT.
2. Viewing angle is the angle at which the contrast ratio is greater than 10. The viewing are determined for the horizontal or 3, 9 o'clock direction and the vertical or 6, 12 o'clock direction with respect to the optical axis which is normal to the LCD surface.
3. Contrast measurements shall be made at viewing angle of $= 0^\circ$ and at the center of the LCD surface. Luminance shall be measured with all pixels in the view field set first to white, then to the dark (black) state. (See FIGURE 1 shown in Appendix) Luminance Contrast Ratio (CR) is defined mathematically.

$$CR = \frac{\text{Luminance when displaying a white raster}}{\text{Luminance when displaying a black raster}}$$

4. Luminance of LCD module shall be made without signal input. Cell transmittance is defined mathematically, BLU provided by BOEDT.

$$\text{Transmittance} = \frac{\text{Luminance of LCD Module}}{\text{Luminance of BLU}}$$

5. The White luminance uniformity on LCD surface is then expressed as :
 $\Delta Y = (\text{Minimum Luminance of 9points} / \text{Maximum Luminance of 9points}) * 100$
 (See FIGURE 2 shown in Appendix).
6. The color chromaticity coordinates specified in Table 4. shall be calculated from the spectral data measured with all pixels first in red, green, blue and white. Measurements shall be made at the center of the panel with BLU.
7. Response time T_g is the average time required for display transition by switching the input signal as below table and is based on Frame rate $f_V = 60\text{Hz}$ to optimize. Each time in below table is defined as appendix Figure 3 and shall be measured by switching the input signal for "any level of gray(bright)" and "any level of gray(dark)"
8. Cross-Talk of one area of the LCD surface by another shall be measured by comparing the luminance (Y_A) of a 25mm diameter area, with all display pixels set to a gray level, to the luminance (Y_B) of that same area when any adjacent area is driven dark. (See FIGURE 4 shown in Appendix).

SPEC. NUMBER	SPEC. TITLE	P
S	MV185WHB-N10 Preliminary Product Specification Rev. P0	9

	PRODUCT GROUP	REV	ISSUE DATE
	TFT- LCD PRODUCT	Rev.P0	May.29,15'

5.0 INTERFACE CONNECTION.

5.1 Electrical Interface Connection

- CN11 Open Cell Side Connector : UJU IS100-300-C23 or Equivalent
User Side Connector : JAE FI-X30H or Equivalent

Pin No	Symbol	Function	Remark
1	NC	No connection	
2	CE	No connection	internal use
3	CTL	No connection	internal use
4	GND	GND Ground	
5	RX0-	Negative LVDS differential data input. Channel 0	
6	RX0+	Positive LVDS differential data input. Channel 0	
7	GND	Ground	Optical: Bist function
8	RX1-	Negative LVDS differential data input. Channel 1	
9	RX1+	Positive LVDS differential data input. Channel 1	
10	GND	Ground	
11	RX2-	Negative LVDS differential data input. Channel 2	
12	RX2+	Positive LVDS differential data input. Channel 2	
13	GND	Ground	
14	RXCLK-	Negative LVDS differential clock input.	
15	RXCLK+	Positive LVDS differential clock input.	
16	GND	Ground	
17	RX3-	Negative LVDS differential data input. Channel 3	
18	RX3+	Positive LVDS differential data input. Channel 3	
19	GND	Ground	
20	NC	Not connection, this pin should be open.	
21	NC	Not connection, this pin should be open.	
22	NC	Not connection, this pin should be open.	
23	GND	Ground	
24	GND	Ground	
25	GND	Ground	
26	VCC	5V Power supply	
27	VCC		
28	VCC		
29	VCC		
30	VCC		

SPEC. NUMBER S	SPEC. TITLE MV185WHB-N10 Preliminary Product Specification Rev. P0	P 10
-------------------	---	---------

	PRODUCT GROUP	REV	ISSUE DATE
	TFT- LCD PRODUCT	Rev.P0	May.29,15'

5.2 LVDS Interface (Tx; THC63LVDF83A or Equivalent)

5.2.1 LVDS Interface

	Input Signal	Transmitter		Interface		MV185WHB-N10 (CN11)	Remark
		Pin No.	Pin No.	System (Tx)	TFT-LCD (Rx)	Pin No.	
L V D S	OR0	51	48 47	OUT0- OUT0+	RXO0- RXO0+	1 2	
	OR1	52					
	OR2	54					
	OR3	55					
	OR4	56					
	OR5	3					
	OG0	4	46 45	OUT1- OUT1+	RXO1- RXO1+	3 4	
	OG1	6					
	OG2	7					
	OG3	11					
	OG4	12					
	OG5	14					
	OB0	15	42 41	OUT2- OUT2+	RXO2- RXO2+	5 6	
	OB1	19					
	OB2	20					
	OB3	22					
	OB4	23					
	OB5	24					
	Hsync	27	40 39	CLK OUT- CLK OUT+	RXO CLK- RXO CLK+	8 9	
	Vsync	28					
	DE	30	38 37	OUT3- OUT3+	RXO3- RXO3+	10 11	
	MCLK	31					
	OR6	50					
	OR7	2					
	OG6	8					
	OG7	10					
	OB6	16					
	OB7	18					
RSVD	25						

SPEC. NUMBER S	SPEC. TITLE MV185WHB-N10 Preliminary Product Specification Rev. P0	P 11
-------------------	---	---------

	PRODUCT GROUP	REV	ISSUE DATE
	TFT- LCD PRODUCT	Rev.P0	May.29,15'

5.3 Data Input Format

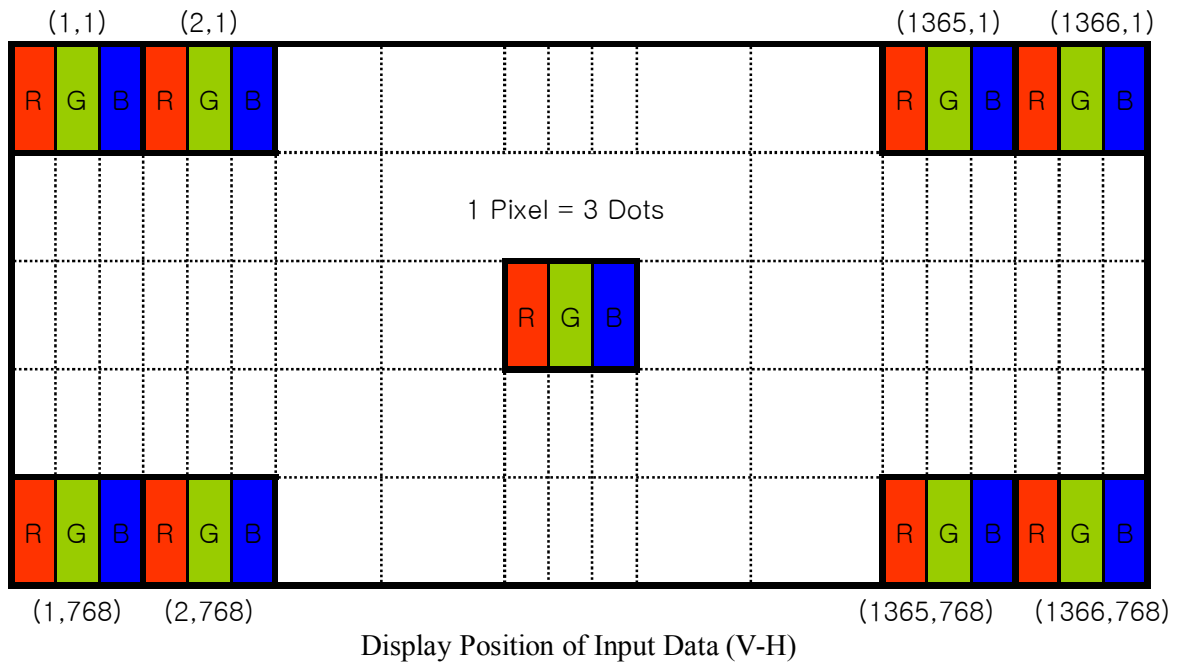

SPEC. NUMBER S	SPEC. TITLE MV185WHB-N10 Preliminary Product Specification Rev. P0	P 12
-------------------	---	---------

	PRODUCT GROUP	REV	ISSUE DATE
	TFT- LCD PRODUCT	Rev.P0	May.29,15'

6.0 SIGNAL TIMING SPECIFICATION

6.1 The MV185WHB-N10 is operated by the DE only.

Item		Symbols	Min	Typ	Max	Unit
Clock	Frequency	1/Tc	50	75.4	95	MHz
	High Time	Tch	-	4/7Tc	-	
	Low Time	Tcl	-	4/7Tc	-	
Frame Period		Tv	778	806	888	lines
			50	60	75	Hz
			20	16.7	13.3	ms
Vertical Display Period		Tvd	-	768	-	lines
One line Scanning Period		Th	1446	1560	1936	clocks
Horizontal Display Period		Thd	-	1366	-	clocks

SPEC. NUMBER S	SPEC. TITLE MV185WHB-N10 Preliminary Product Specification Rev. P0	P 13
-------------------	---	---------

	PRODUCT GROUP	REV	ISSUE DATE
	TFT- LCD PRODUCT	Rev.P0	May.29,15'

6.2 LVDS Rx Interface Timing Parameter

The specification of the LVDS Rx interface timing parameter is shown in Table 4.

<Table 4. LVDS Rx Interface Timing Specification>

Item	Symbol	Min	Typ	Max	Unit	Remark
CLKIN Period	tRCIP	10.60	13.25	20.00	nsec	
Input Data 0	tRIP1	-0.4	0.0	+0.4	nsec	
Input Data 1	tRIP0	tRCIP/7-0.4	tRCIP/7	tRCIP/7+0.4	nsec	
Input Data 2	tRIP6	2 × tRCIP/7-0.4	2 × tRCIP/7	2 × tRCIP/7+0.4	nsec	
Input Data 3	tRIP5	3 × tRCIP/7-0.4	3 × tRCIP/7	3 × tRCIP/7+0.4	nsec	
Input Data 4	tRIP4	4 × tRCIP/7-0.4	4 × tRCIP/7	4 × tRCIP/7+0.4	nsec	
Input Data 5	tRIP3	5 × tRCIP/7-0.4	5 × tRCIP/7	5 × tRCIP/7+0.4	nsec	
Input Data 6	tRIP2	6 × tRCIP/7-0.4	6 × tRCIP/7	6 × tRCIP/7+0.4	nsec	

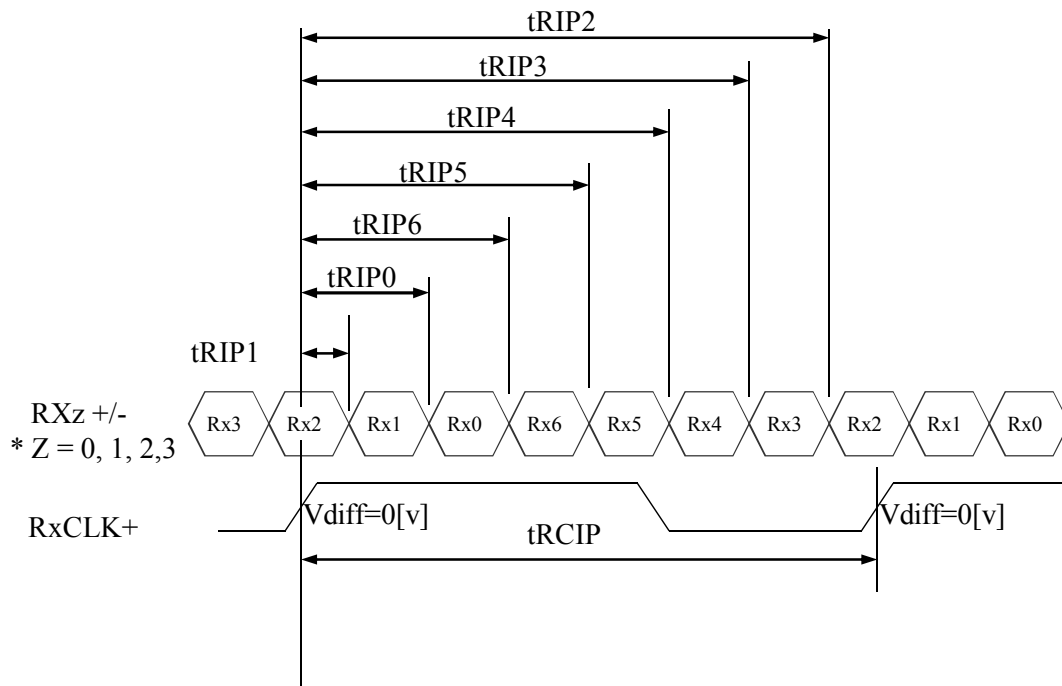

* $V_{diff} = (RXz+) - (RXz-), \dots, (RXCLK+) - (RXCLK-)$

SPEC. NUMBER S	SPEC. TITLE MV185WHB-N10 Preliminary Product Specification Rev. P0	P 14
-------------------	---	---------

	PRODUCT GROUP	REV	ISSUE DATE
	TFT- LCD PRODUCT	Rev.P0	May.29,15'

7.0 SIGNAL TIMING WAVEFORMS OF INTERFACE SIGNAL

7.1 Sync Timing Waveforms

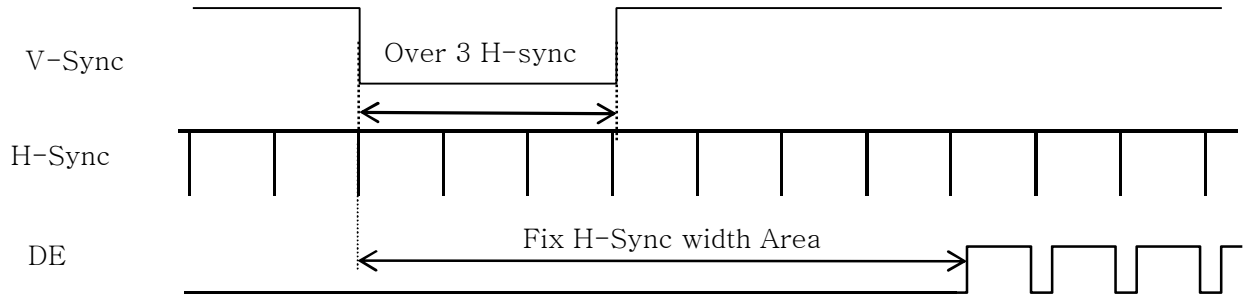

- 1) Need over 3 H-sync during V-Sync Low
- 2) Fix H-Sync width from V-Sync falling edge to first rising edge

7.2 Vertical Timing Waveforms

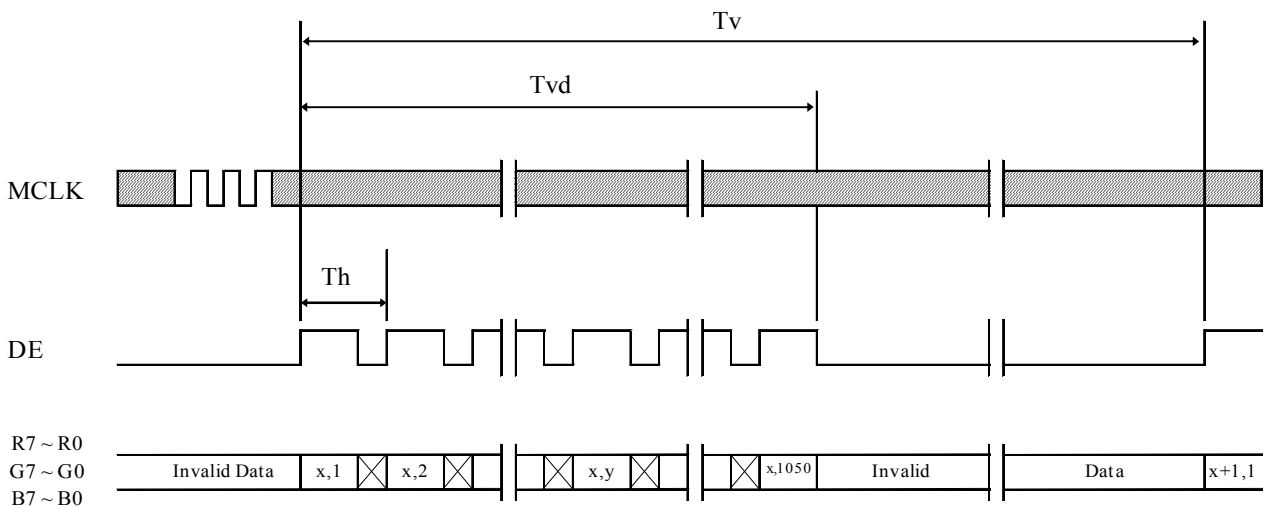

SPEC. NUMBER	SPEC. TITLE	P
S	MV185WHB-N10 Preliminary Product Specification Rev. P0	15

	PRODUCT GROUP	REV	ISSUE DATE
	TFT- LCD PRODUCT	Rev.P0	May.29,15'

7.3 Horizontal Timing Waveforms

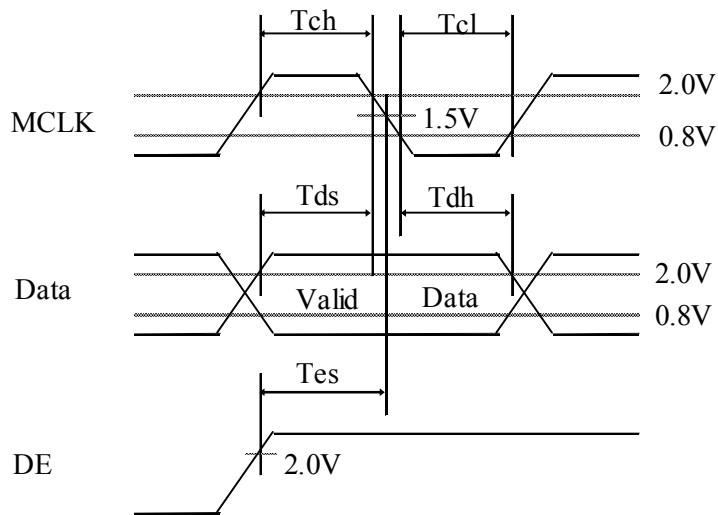
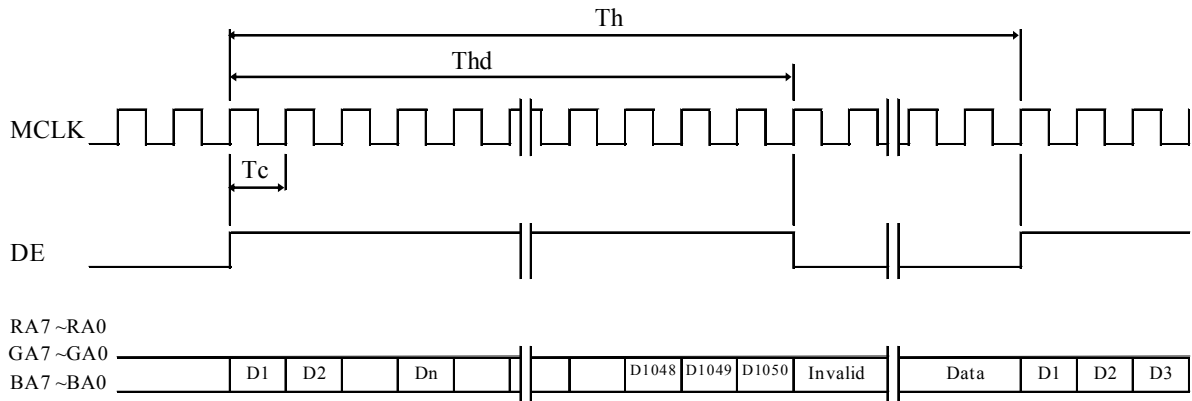

SPEC. NUMBER S	SPEC. TITLE MV185WHB-N10 Preliminary Product Specification Rev. P0	P 16
-------------------	---	---------

	PRODUCT GROUP	REV	ISSUE DATE
	TFT- LCD PRODUCT	Rev.P0	May.29,15'

8.0 INPUT SIGNALS, BASIC DISPLAY COLORS & GRAY SCALE OF COLORS

Color & Gray Scale		RED DATA								GREEN DATA								BLUE DATA							
		R7	R6	R5	R4	R3	R2	R1	R0	G7	G6	G5	G4	G3	G2	G1	G0	B7	B6	B5	B4	B3	B2	B1	B0
Basic Colors	Black	0	0	0	0	0	0	0	0	0	0	0	0	0	0	0	0	0	0	0	0	0	0	0	0
	Blue	0	0	0	0	0	0	0	0	0	0	0	0	0	0	0	0	1	1	1	1	1	1	1	1
	Green	0	0	0	0	0	0	0	0	1	1	1	1	1	1	1	1	0	0	0	0	0	0	0	0
	Cyan	0	0	0	0	0	0	0	0	1	1	1	1	1	1	1	1	1	1	1	1	1	1	1	1
	Red	1	1	1	1	1	1	1	1	0	0	0	0	0	0	0	0	0	0	0	0	0	0	0	0
	Magenta	1	1	1	1	1	1	1	1	0	0	0	0	0	0	0	0	1	1	1	1	1	1	1	1
	Yellow	1	1	1	1	1	1	1	1	1	1	1	1	1	1	1	1	0	0	0	0	0	0	0	0
	White	1	1	1	1	1	1	1	1	1	1	1	1	1	1	1	1	1	1	1	1	1	1	1	1
Gray Scale of RED	Black	0	0	0	0	0	0	0	0	0	0	0	0	0	0	0	0	0	0	0	0	0	0	0	0
	△	0	0	0	0	0	0	0	1	0	0	0	0	0	0	0	0	0	0	0	0	0	0	0	0
	Darker	0	0	0	0	0	0	1	0	0	0	0	0	0	0	0	0	0	0	0	0	0	0	0	0
	△	↑								↑								↑							
	▽	↓								↓								↓							
	Brighter	1	1	1	1	1	1	0	1	0	0	0	0	0	0	0	0	0	0	0	0	0	0	0	0
	▽	1	1	1	1	1	1	1	0	0	0	0	0	0	0	0	0	0	0	0	0	0	0	0	0
	Red	1	1	1	1	1	1	1	1	0	0	0	0	0	0	0	0	0	0	0	0	0	0	0	0
Gray Scale of GREEN	Black	0	0	0	0	0	0	0	0	0	0	0	0	0	0	0	0	0	0	0	0	0	0	0	0
	△	0	0	0	0	0	0	0	0	0	0	0	0	0	0	0	1	0	0	0	0	0	0	0	0
	Darker	0	0	0	0	0	0	0	0	0	0	0	0	0	0	1	0	0	0	0	0	0	0	0	0
	△	↑								↑								↑							
	▽	↓								↓								↓							
	Brighter	0	0	0	0	0	0	0	0	1	1	1	1	1	1	0	1	0	0	0	0	0	0	0	0
	▽	0	0	0	0	0	0	0	0	1	1	1	1	1	1	1	0	0	0	0	0	0	0	0	0
	Green	0	0	0	0	0	0	0	0	1	1	1	1	1	1	1	1	0	0	0	0	0	0	0	0
Gray Scale of BLUE	Black	0	0	0	0	0	0	0	0	0	0	0	0	0	0	0	0	0	0	0	0	0	0	0	0
	△	0	0	0	0	0	0	0	0	0	0	0	0	0	0	0	0	0	0	0	0	0	0	0	1
	Darker	0	0	0	0	0	0	0	0	0	0	0	0	0	0	0	0	0	0	0	0	0	0	1	0
	△	↑								↑								↑							
	▽	↓								↓								↓							
	Brighter	0	0	0	0	0	0	0	0	0	0	0	0	0	0	0	0	1	1	1	1	1	1	0	1
	▽	0	0	0	0	0	0	0	0	0	0	0	0	0	0	0	0	1	1	1	1	1	1	1	0
	Blue	0	0	0	0	0	0	0	0	0	0	0	0	0	0	0	0	1	1	1	1	1	1	1	1
Gray Scale of WHITE	Black	0	0	0	0	0	0	0	0	0	0	0	0	0	0	0	0	0	0	0	0	0	0	0	0
	△	0	0	0	0	0	0	0	1	0	0	0	0	0	0	0	1	0	0	0	0	0	0	0	1
	Darker	0	0	0	0	0	0	1	0	0	0	0	0	0	0	1	0	0	0	0	0	0	0	1	0
	△	↑								↑								↑							
	▽	↓								↓								↓							
	Brighter	1	1	1	1	1	1	0	1	1	1	1	1	1	1	0	1	1	1	1	1	1	1	0	1
	▽	1	1	1	1	1	1	1	0	1	1	1	1	1	1	1	0	1	1	1	1	1	1	1	0
	White	1	1	1	1	1	1	1	1	1	1	1	1	1	1	1	1	1	1	1	1	1	1	1	1

SPEC. NUMBER	SPEC. TITLE	P
S	MV185WHB-N10 Preliminary Product Specification Rev. P0	17
B2010-8002-A (3/3)		A4(2)

	PRODUCT GROUP	REV	ISSUE DATE
	TFT- LCD PRODUCT	Rev.P0	May.29,15'

9.0 POWER SEQUENCE

To prevent a latch-up or DC operation of the LCD module, the power on/off sequence shall be as shown in below

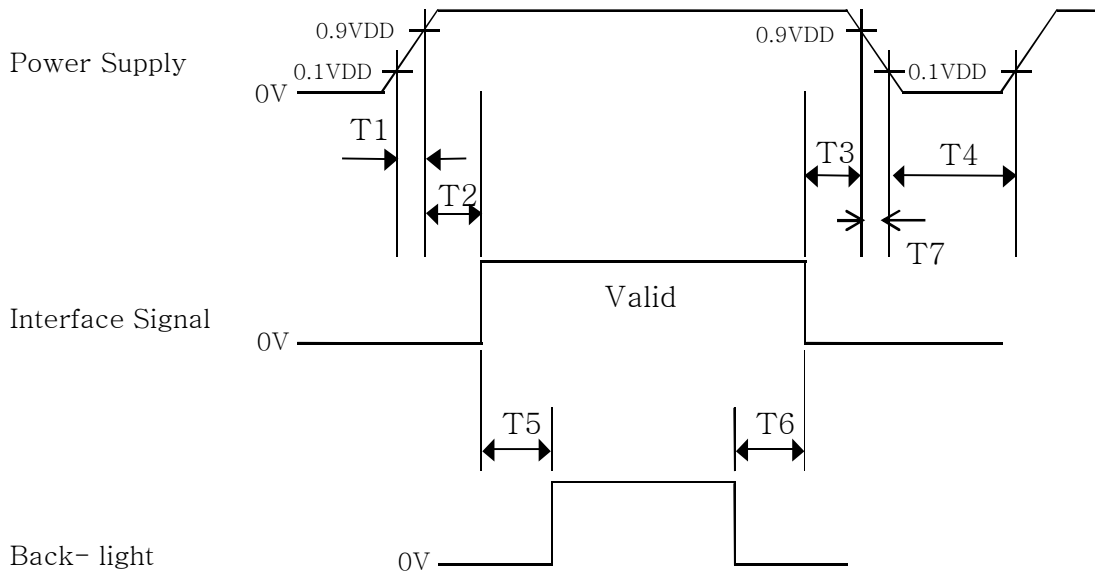

- $0.5 \text{ ms} \leq T1 \leq 10 \text{ ms}$
- $0 \leq T2 \leq 50 \text{ ms}$
- $0 \leq T3 \leq 50 \text{ ms}$
- $1 \text{ sec} \leq T4$
- $200 \text{ ms} \leq T5$
- $200 \text{ ms} \leq T6$

Notes:

1. When the power supply VDD is 0V, keep the level of input signals on the low or keep high impedance.
2. Do not keep the interface signal high impedance when power is on.
3. Back Light must be turn on after power for logic and interface signal are valid.
4. T7 decreases smoothly, there is none re-bouncing voltage.

SPEC. NUMBER S	SPEC. TITLE MV185WHB-N10 Preliminary Product Specification Rev. P0	P 18
-------------------	---	---------

	PRODUCT GROUP	REV	ISSUE DATE
	TFT- LCD PRODUCT	Rev.P0	May.29,15'

10.0 MECHANICAL CHARACTERISTICS

10.1 Dimensional Requirements

FIGURE 6 (located in Appendix) shows mechanical outlines for the open cell MV185WHB-N10. Other parameters are shown in Table 5.

<Table 5. Dimensional Parameters>

Parameter	Specification	Unit
Weight	TBD(typ.)	gram
Active area	409.8(H) × 230.4(V)	mm
Pixel pitch	0.3(H) × 0.3(V)	mm
Number of pixels	1366(H) × 768(V) (1 pixel = R + G + B dots)	pixels

10.2 Anti-Glare and Polarizer Hardness.

The surface of the LCD has an anti-glare coating to minimize reflection and a coating to reduce scratching.

SPEC. NUMBER S	SPEC. TITLE MV185WHB-N10 Preliminary Product Specification Rev. P0	P 19
-------------------	---	---------

	PRODUCT GROUP	REV	ISSUE DATE
	TFT- LCD PRODUCT	Rev.P0	May.29,15'

11.0 RELIABILITY TEST

The Reliability test items and its conditions are shown in below.
 <Table 6. Reliability Test Parameters >

No	Test Items	Conditions	
1	High temperature storage test	Ta = 60 °C, 240 hrs	Note 1
2	Low temperature storage test	Ta = -20 °C, 240 hrs	
3	High temperature & high humidity (operation test)	Ta = 50 °C, 80%RH, 240hrs	
4	High temperature operation test	Ta = 50 °C, 240hrs	
5	Low temperature operation test	Ta = -5 °C, 240hrs	
6	Thermal shock	Ta = -20 °C ↔ 60 °C (0.5 hr), 100 cycle	
7	Electro-static discharge test (non-operating)	Air: 150 pF, 330Ω, 15 KV Contact: 150 pF, 330Ω, 8 KV	
8	Packing Vibration Test	1.47Grms, 1~200Hz, Random X(30min), Y(30min), +Z (1hr)	Note 2
9	Drop Test	1Angle,3Edge,6Face Height: JIS-Z-0200 Level 1	

Notes:

1. The tests are done with LCD modules. (Use BOEDT&BJCT BLU)
2. The test is done with a package (20pcs open cell / 1 Box) shown in section 14.

SPEC. NUMBER S	SPEC. TITLE MV185WHB-N10 Preliminary Product Specification Rev. P0	P 20
-------------------	---	---------

	PRODUCT GROUP	REV	ISSUE DATE
	TFT- LCD PRODUCT	Rev.P0	May.29,15'

12.0 HANDLING & CAUTIONS

- (1) Cautions when taking out the open cell
 - Pick the pouch only, when taking out open cell from a shipping package.
- (2) Cautions for handling the open cell
 - As the electrostatic discharges may break the LCD open cell, handle the LCD open cell with care. Peel a protection sheet off from the LCD panel surface as slowly as possible.
 - As the LCD panel is made from fragile glass material, impulse and pressure to the LCD module should be avoided.
 - As the surface of the polarizer is very soft and easily scratched, use a soft dry cloth without chemicals for cleaning.
 - Do not pull the interface connector in or out while the LCD open cell is operating.
 - Handle connectors and cables with care.
- (3) Cautions for the operation
 - When the open cell is operating, do not lose CLK, ENAB signals. If any one of these signals is lost, the LCD panel would be damaged.
 - Obey the supply voltage sequence. If wrong sequence is applied, the open cell would be damaged.
- (4) Cautions for the atmosphere
 - Dew drop atmosphere should be avoided.
 - Do not store and/or operate the LCD open cell in a high temperature and/or humidity atmosphere. Storage in an electro-conductive polymer packing pouch and under relatively low temperature atmosphere is recommended.
- (5) Cautions for the open cell characteristics
 - Do not apply fixed pattern data signal to the LCD open cell at product aging.
 - Applying fixed pattern for a long time may cause image sticking.
- (6) Other cautions
 - Do not re-adjust variable resistor or switch etc.
 - When returning the open cell for repair or etc., Please pack the open cell not to be broken. We recommend to use the original shipping packages.

SPEC. NUMBER	SPEC. TITLE	P
S	MV185WHB-N10 Preliminary Product Specification Rev. P0	21

	PRODUCT GROUP	REV	ISSUE DATE
	TFT- LCD PRODUCT	Rev.P0	May.29,15'

15.0 APPENDIX

Figure 1. Measurement Set Up

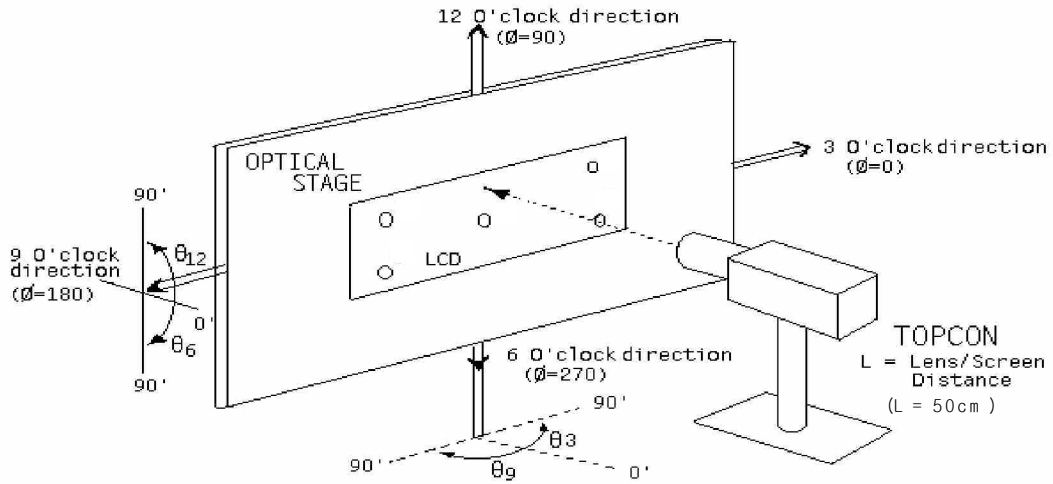
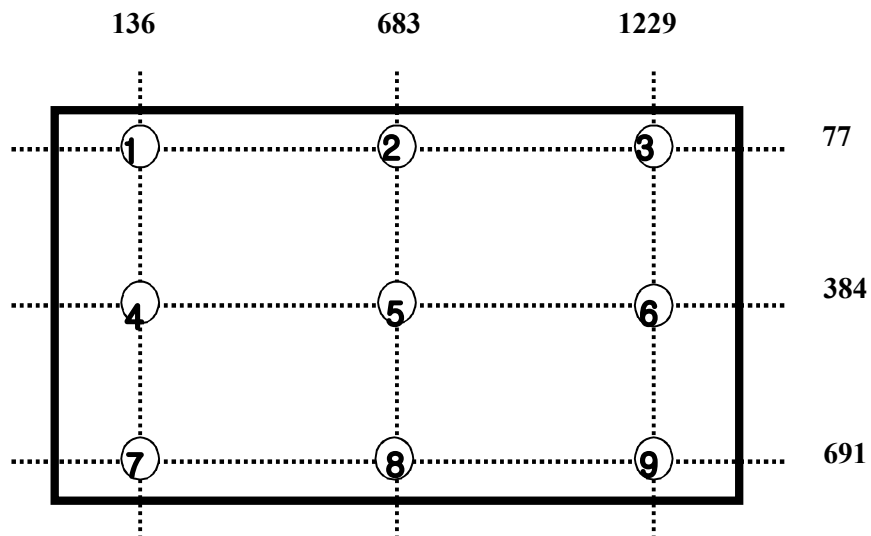

Figure 2. White Luminance and Uniformity Measurement Locations (9 points)



SPEC. NUMBER S	SPEC. TITLE MV185WHB-N10 Preliminary Product Specification Rev. P0	P 25
-------------------	---	---------

	PRODUCT GROUP	REV	ISSUE DATE
	TFT- LCD PRODUCT	Rev.P0	May.29,15'

Figure 3. Response Time Testing

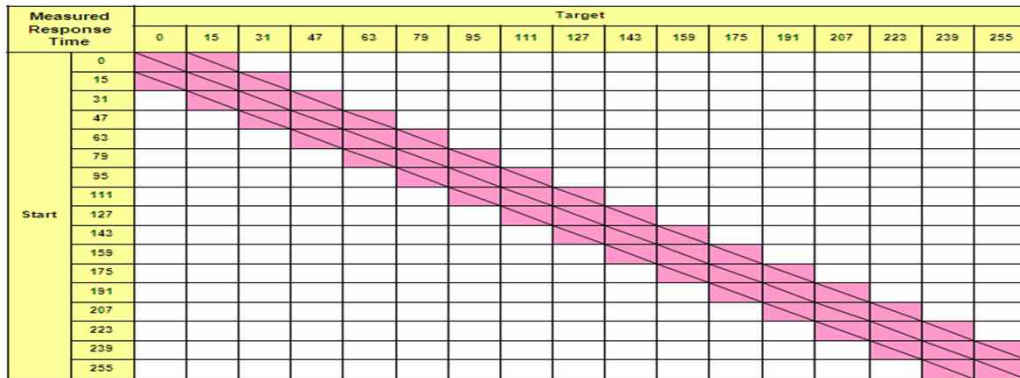
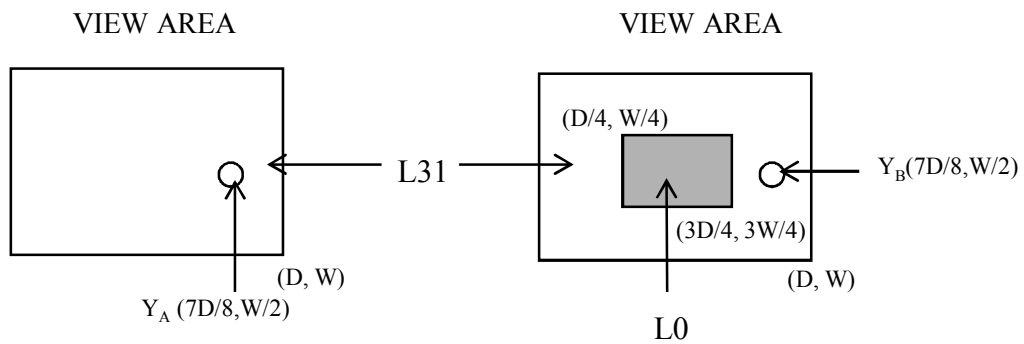

Figure 4. Cross Modulation Test Description



$$\text{Cross-Talk (\%)} = \left| \frac{Y_B - Y_A}{Y_A} \right| \times 100$$

Where: Y_A = Initial luminance of measured area (cd/m²)
 Y_B = Subsequent luminance of measured area (cd/m²)
The location measured will be exactly the same in both patterns

SPEC. NUMBER S	SPEC. TITLE MV185WHB-N10 Preliminary Product Specification Rev. P0	P 26
-------------------	---	---------

	PRODUCT GROUP	REV	ISSUE DATE
	PRODUCT SPEC	O	
SPEC. NUMBER	SPEC. TITLE		PAGE 5 OF 28

4. . BACKLIGHT UNIT

Parameter	Symbol	Value			Unit	Note
		Min.	Typ.	Max.		
LED Light Bar Input Voltage Per Input Pin	VPIN	36	37	39.6	V	(1), Duty=100%, IPIN=(60mA)
灯条总电流 I	IPIN	---	240	240	mA	(1), (2) Duty=100%
LED Life Time	LLED	30000			Hrs	(3)
Power Consumption	PBL	8.64	- - -	- - -	W	(1) Duty=100%, IPIN=(60mA)

Note (1) LED light bar input voltage and current are measured by utilizing a true RMS multimeter as shown below:

Note (2) $PBL = IPIN \times VPIN$

Note (3) The lifetime of LED is defined as the time when LED packages continue to operate under the conditions at $T_a = 25 \pm 2 \text{ }^\circ\text{C}$ and $I = (25)\text{mA}$ (per chip) until the brightness becomes $\leq 50\%$ of its original value.

灯条串并定义及接口型号定义：4014 (60MA) 灯珠 12串4并

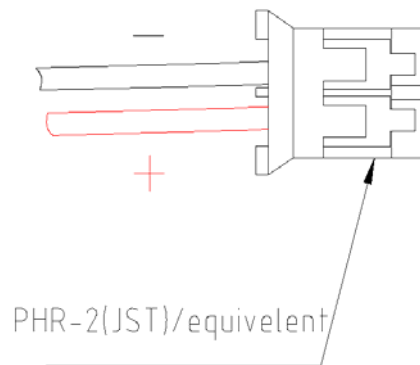

	PRODUCT GROUP	REV	ISSUE DATE
	PRODUCT SPEC	O	
SPEC. NUMBER	SPEC. TITLE		PAGE 26 OF 28

环境温度(Ta)=25°C±2 湿度 HR=65%±10

	項目 Item	單位 unit	規 格 Sption			備注 Remark	
			MIN	TYP	MAX		
1	模組亮度 BLU Brightness	Center point	cd/m ²	180	200	---	Center point (NOTE 1)
	均勻性 Uniformity	9 点		72	75	---	(NOTE2)
2	模組色度 LCM CIE	x	---	-0.030	0.313	+0.030	Center point
		y	---	-0.030	0.329	+0.030	Center point

中心点为最亮点 The center brightness data ia the maximum
 下图示中 9 点之最小数值点比中心点，均匀性定义：Minimum(1-9)/Maximum(5)
 mum value of 9 point divided by the center ,

由 Autodesk 教育版产品制作

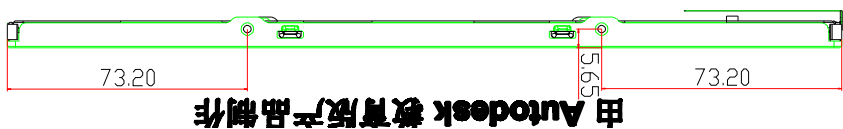
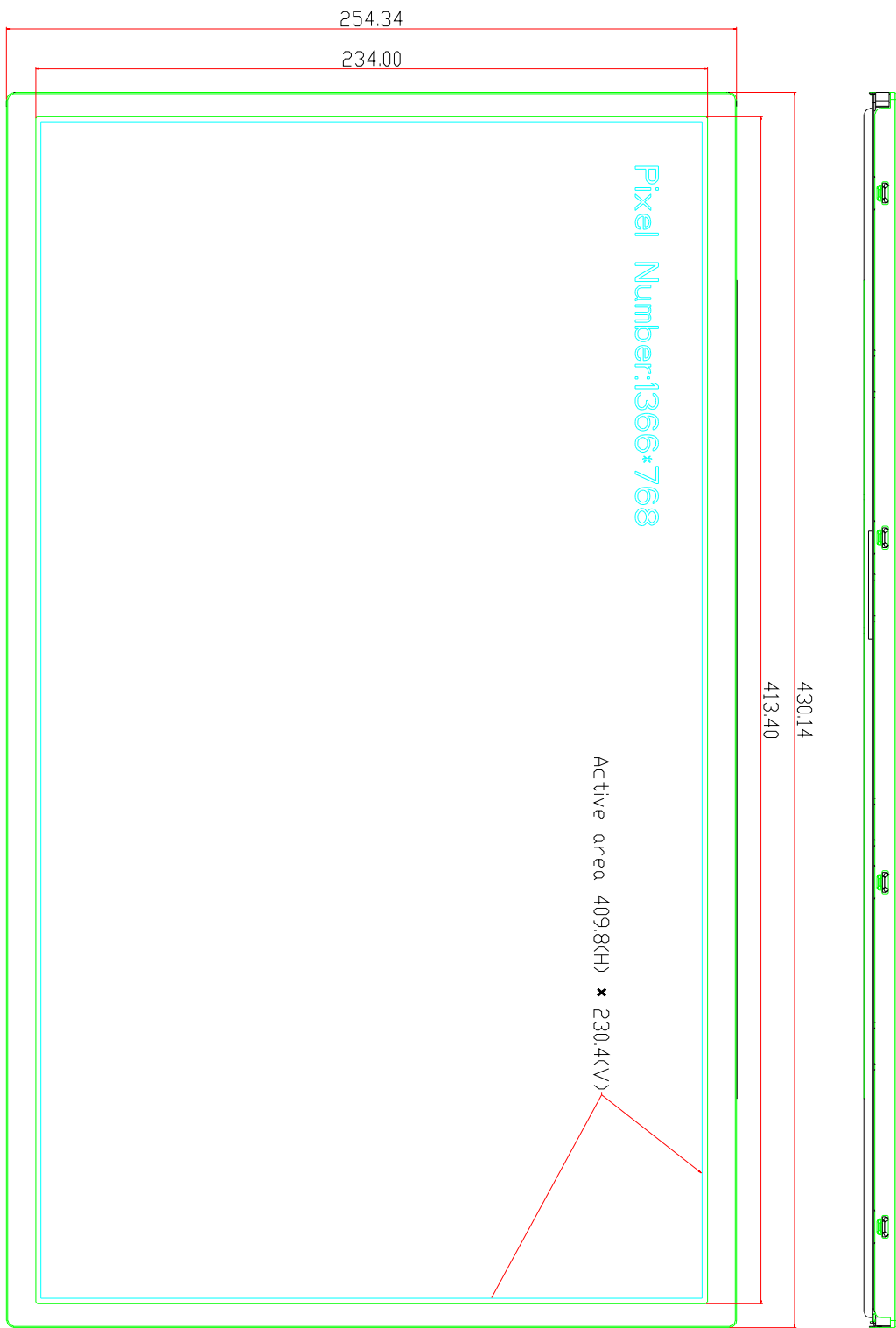
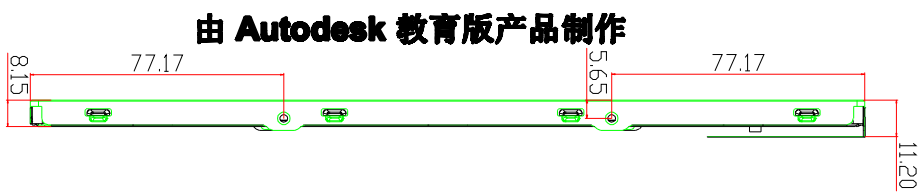

由 Autodesk 教育版产品制作

11.20

