

# MV2002SG

## IC for LED Lighting

### Feature

- Critical conduction mode
- Dual channel
- Gate output stop function
- Remote control
- Internal regulator : 3.3V
- Linear / PWM Dimming
- Alarm signal output
- Deep dimming (1% or less)
- Vcc over voltage protection (latch)
- LED short-circuit protection (auto reset)
- Thermal shutdown (auto reset)
- Vreg over current protection (auto reset)
- Pb free
- RoHS:Yes

### Outline

House Name: SOP16



1 絶対最大定格(Ta=25°C)

1 Absolute Maximum Ratings (at Ta=25°C)

1-1 熱規格

1-1 Thermal Ratings

項目 Item	記号 Symbol	規格値 Ratings	単位 Unit
保存温度 Storage temperature	Tstg	-55~150	°C
接合部温度 Junction temperature	Tj	-40~150	°C
許容損失 Total power dissipation	Pt	0.8	W
熱抵抗 Thermal resistance	$\theta_{ja}$	147	°C/W

ガラエポ基板:114.3mm×76.2mm, 厚さ:1.6mm, 内面銅箔サイズ 74.2mm×74.2mm, 厚さ:35 $\mu$ m  
Glass-Epoxy Board : 114.3mm×76.2mm , Thickness: 1.6mm, inside copper foil 74.2mm×74.2mm , Thickness: 35 $\mu$ m

1-2 電気的規格

1-2 Electrical Ratings

項目 Item	記号 Symbol	規格値 Ratings	単位 Unit
Vcc端子最大印加電圧 Vcc maximum applied voltage	Vcc	22	V
Vcc端子逆バイアス電圧 Vcc reverse bias voltage	-----	-0.5	V
REF, RC端子最大印加電圧 REF, RC maximum applied voltage	Vref, Vrc	5.5	V
Svout, Svin端子最大印加電圧 Svout, Svin maximum applied voltage	Vsvout, Vsvin	5.0	V
CS端子最大印加電圧 CS maximum applied voltage	Vcs	4.5	V
Svin, CS, REF, RC端子逆バイアス電圧 Svin, CS, REF reverse bias voltage	-----	-0.5	V
Svout 端子最大電流 Svout maximum current	Isvout	-2	mA

注意 : 本仕様書に記載されていない項目、使用条件、論理の組み合わせでの使用は保証していません。  
記載されている以外の条件で使用する場合は必ず事前に当社担当営業部門までご相談下さい。  
記載内容は改良などのためにお断り無しに変更することがあります。

Notes : Using with parameters, condition of use and logic controls that are not specified in the specifications are not assured.  
When used with the conditions that are not specified, please consult us in advance.  
The contents described herein are subject to change without notice.

2 推奨動作条件

2 Recommended Operation Conditions

項目 Item	記号 Symbol	推奨値 Recommended value			単位 Unit
		min	typ	max	
動作温度 Operating temperature	Top	-30	---	125	°C
Vcc端子印加電圧 Vcc applied voltage	Vcc	10	---	16	V

注意 : 上記の規格範囲内においても、製品寿命に関しましてはお客様の使用環境により異なりますので、長寿命を期待される製品  
にご使用される場合には、Tj=100°C以下でご使用頂く事を推奨致します。

Notes : The product life depends on the condition of use even within the above operating conditions.  
Using at Tj = 100°C or less is recommended for the equipment where a long life is expected.

5SK-145032-1

### 3 電氣的・熱的特性 (Ta=25°C)

#### 3 Electrical/Thermal Characteristics (at Ta=25°C)

項目 Item	記号 Symbol	条件 Condition	規格値 Ratings			単位 Unit
			min	typ	max	

#### Vcc端子 (Vcc Terminal)

動作開始電圧 Start up supply voltage	Vcc_start		7.5	8.15	8.8	V
ヒステリシス電圧 Hysteresis voltage	Vcc_hys		0.9	1.05	1.2	V
Vcc電流(動作時1) Vcc current (active mode1)	Icc_act1	Vcc=10V, Gate=OPEN, 50kHz	3.3	3.8	4.3	mA
Vcc電流(動作時2) Vcc current (active mode2)	Icc_act2	Vcc=10V, Gate=1000pF, 50kHz	4.3	4.8	5.3	mA
Vcc電流(起動前) Vcc current (stand-by)	Icc_stby	Vcc=Vcc_start-0.5V, REF=3V	2.8	3.2	3.6	mA
Vcc過電圧保護電圧 Vcc over voltage threshold	VccOVP		19.7	20.7	21.7	V

#### Gate端子 (Gate Terminal)

Gate High電圧 *1 Gate voltage (high level)	VG_H		Vcc-0.2	---	---	V
Gate Low電圧 Gate voltage (low level)	VG_L		---	---	0.2	V
ソース電流 Sourcing current	IG_source	Vcc=10V, Gate=0V	-58	-46	-34	mA
シンク電流 Sinking current	IG_sink	Vcc=10V, Gate=10V	400	475	550	mA

#### Svin, Svout端子 (Svin,Svout Terminal)

Svin端子内部プルダウン抵抗 Internal pull-down resistance at Svin	R_Svin		23.5	26.0	28.5	kΩ
Svout端子内部プルダウン抵抗 Internal pull-down resistance at Svout	R_Svout		22.5	25.0	27.5	kΩ
内部プルダウン抵抗相対精度 Relative accuracy of internal pull-down resistance	R_Svratio	R_Svin / R_Svout	1.02	1.04	1.06	-
応答遅れ時間 *1 Delay time from Sv-detection to GATE-on	Td_on	Gate=OPEN	---	100	---	ns

#### CS端子 (CS Terminal)

電流検出しきい値(REF=3.3V) Current sense threshold voltage	Vth_CS	Vcc=10V, REF=3.3V	0.550	0.585	0.620	V
電流検出しきい値(REF=2.7V) Current sense threshold voltage	Vth_CS_2.7	Vcc=10V, REF=2.7V	0.516	0.538	0.560	V
電流検出しきい値(REF=2.5V) Current sense threshold voltage	Vth_CS_2.5	Vcc=10V, REF=2.5V	0.471	0.498	0.525	V
電流検出しきい値(REF=1.0V) Current sense threshold voltage	Vth_CS_1.0	Vcc=10V, REF=1.0V	0.163	0.198	0.233	V
応答遅れ時間 *1 Delay time from CS-detection to GATE-off	Td_off	Gate=OPEN	---	90	---	ns
リーディングエッジブランク時間*1 Leading Edge Blanking time	T_LEB		---	210	---	ns

\*1 設計保証

\*1 This parameter is not tested during production, by design it is guaranteed.

項目 Item	記号 Symbol	条件 Condition	規格値 Ratings			単位 Unit
			min	typ	max	

**REF端子 (REF Terminal)**

発振開始REF端子しきい値電圧 GATE-on REF threshold voltage	Vth_REF_st		0.170	0.205	0.240	V
ヒステリシス電圧 Hysteresis voltage	Vth_REF_hys		0.010	0.030	0.050	V
最大オフ時間 Maximum off time	Toff_max	REF=Vth_REF_st+10mV	100	135	170	μs
最小オフ時間 Minimum off time	Toff_min	REF=3V	1.5	1.9	2.3	μs
最大オン時間 Maximum on time	Ton_max		11.0	15.0	19.0	μs
最小オン時間 *1 Minimum on time	Ton_min		---	300	500	ns
リスタート時間 Restart time	Trestart		130	185	240	μs

**Vreg端子 (Vreg terminal)**

Vreg端子電圧 Vreg terminal voltage	Vreg	Vcc=10V, Ireg=0mA	3.17	3.30	3.43	V
Vreg端子ロードレギュレーション Vreg terminal load regulation	Vreg_load	Vcc=10V, Ireg=15mA	---	-0.015	-0.033	V
Vreg端子出力電流 Vreg terminal output current	Ireg	Vcc=10V	---	---	-35	mA
動作開始電圧 Start up voltage	Vreg_start		2.60	2.85	3.10	V
ヒステリシス電圧 Hysteresis voltage	Vreg_hys		0.30	0.40	0.50	V

**RC端子 (RC Terminal)**

発振開始RC端子しきい値電圧 GATE-on RC threshold voltage	Vth_RC_st		1.50	1.90	2.30	V
ヒステリシス電圧 Hysteresis voltage	Vth_RC_hys		0.10	0.35	0.60	V

**Alarm端子 (Alarm Terminal)**

アブノーマル検出時 端子電圧 Alarm terminal voltage at abnormal	Valarm_H	Vcc=10V, Vcs=4V	3.17	3.30	3.43	V
通常時 端子電圧 Alarm terminal voltage at normal	Valarm_L	Vcc=10V	---	---	0.20	V

**PWM調光入力信号 (PWM Dimming input signal)**

PWM信号最大周波数 PWM signal maximum frequency	f_PWM		---	---	1	kHz
PWM信号最小ON_DUTY PWM signal minimum On-Duty	Duty_PWM		1	---	---	%

\*1 設計保証

\*1 This parameter is not tested during production, by design it is guaranteed.

4 ブロック図  
4 Block Diagram

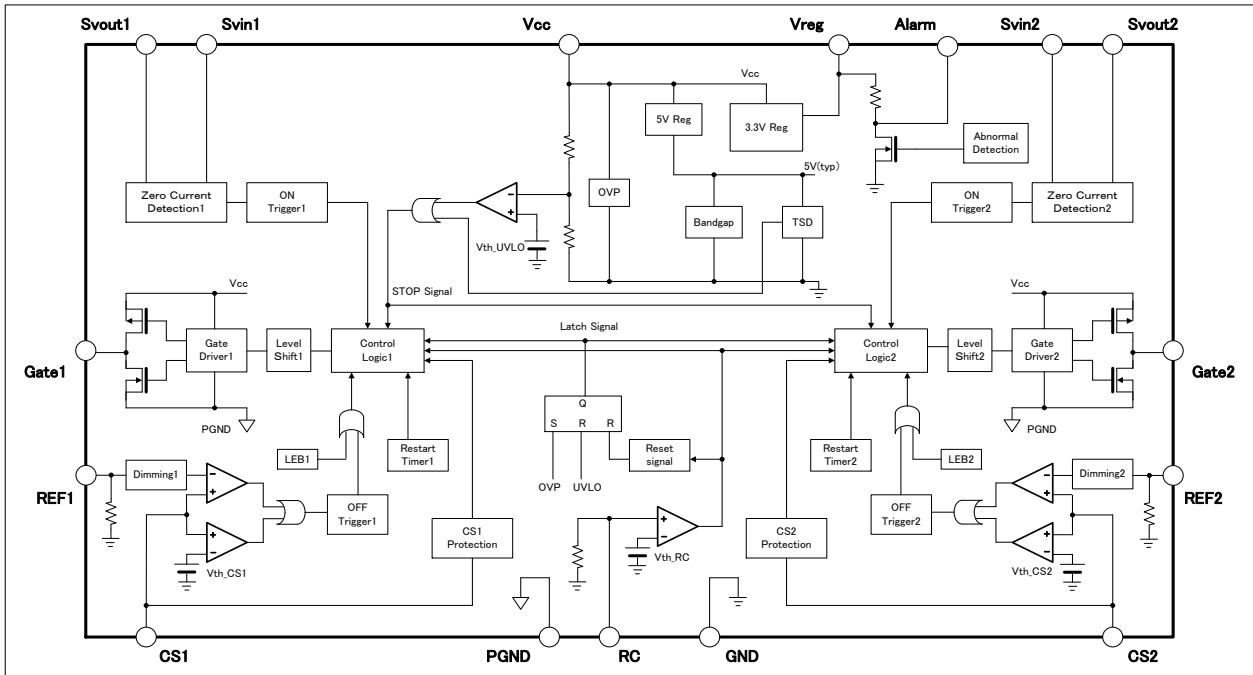

端子番号	記号	端子名
1	RC	リモートコントロール端子 remote control terminal
2	REF1	CH1 調光端子 CH1 dimming terminal
3	Svout1	CH1 ゼロ電流検出端子 CH1 zero current detection terminal
4	Svin1	CH1 ゼロ電流基準端子 CH1 zero current reference terminal
5	CS1	CH1 電流検出端子 CH1 current sense terminal
6	Gate1	CH1 主スイッチ用MOSFET駆動端子 CH1 the output terminal for a MOSFET drive
7	GND	グラウンド端子 GND terminal
8	PGND	パワーグラウンド端子 PGND terminal
9	Vcc	IC電源端子 power supply terminal
10	Gate2	CH2 主スイッチ用MOSFET駆動端子 CH2 the output terminal for a MOSFET drive
11	CS2	CH2 電流検出端子 CH2 current sense terminal
12	Svin2	CH2 ゼロ電流基準端子 CH2 zero current reference terminal
13	Svout2	CH2 ゼロ電流検出端子 CH2 zero current detection terminal
14	REF2	CH2 調光端子 CH2 dimming terminal
15	Alarm	アラーム送出端子 alarm signal out terminal
16	Vreg	3.3V 外部電源端子 3.3V regulator terminal

5 端子配列  
5 Pin Assignment

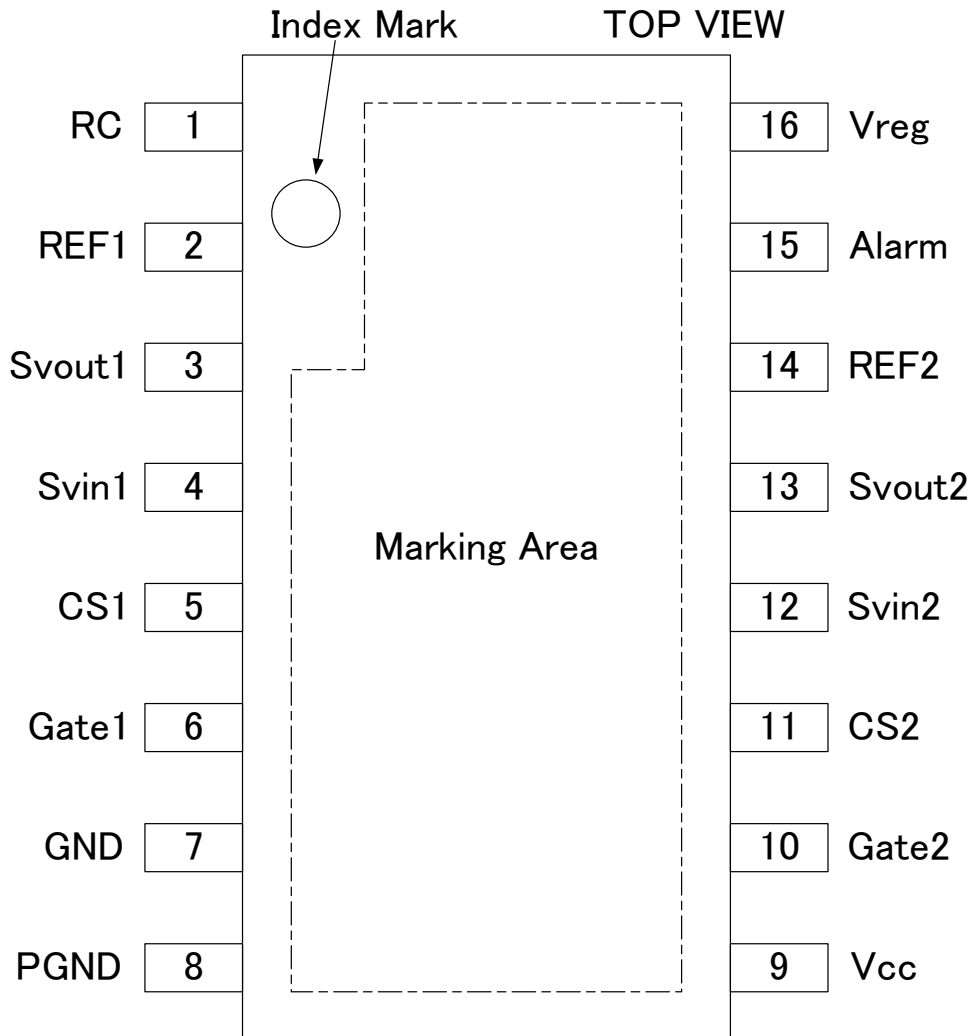

■ REF電圧-出力電流特性 (Ta=25°C)  
REF voltage-Output current characteristic (at Ta=25°C)  
Vin=250Vdc  
Vo=140V

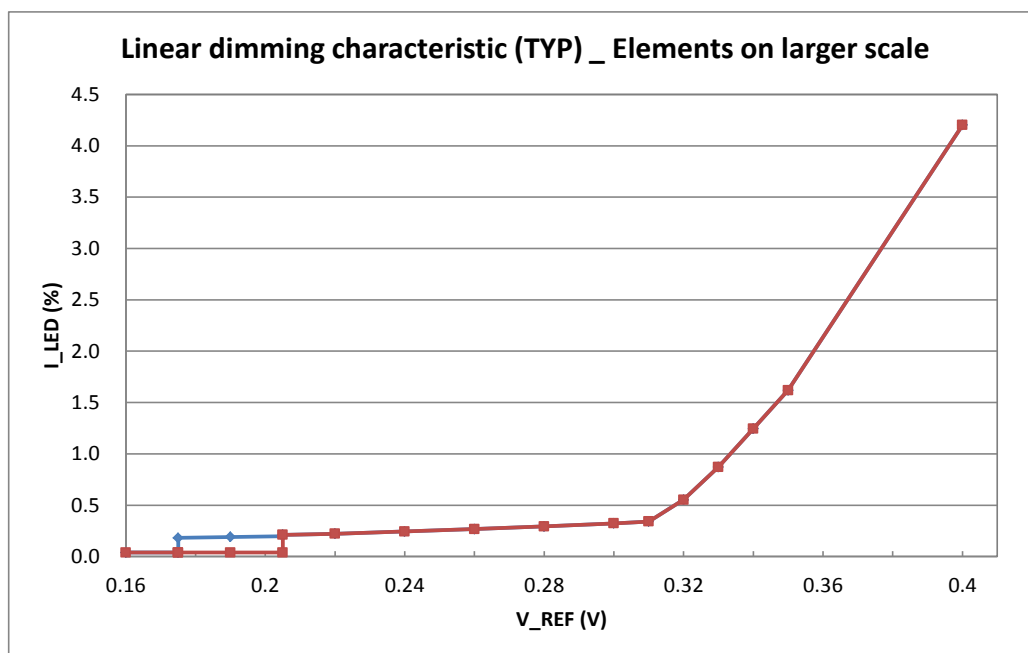
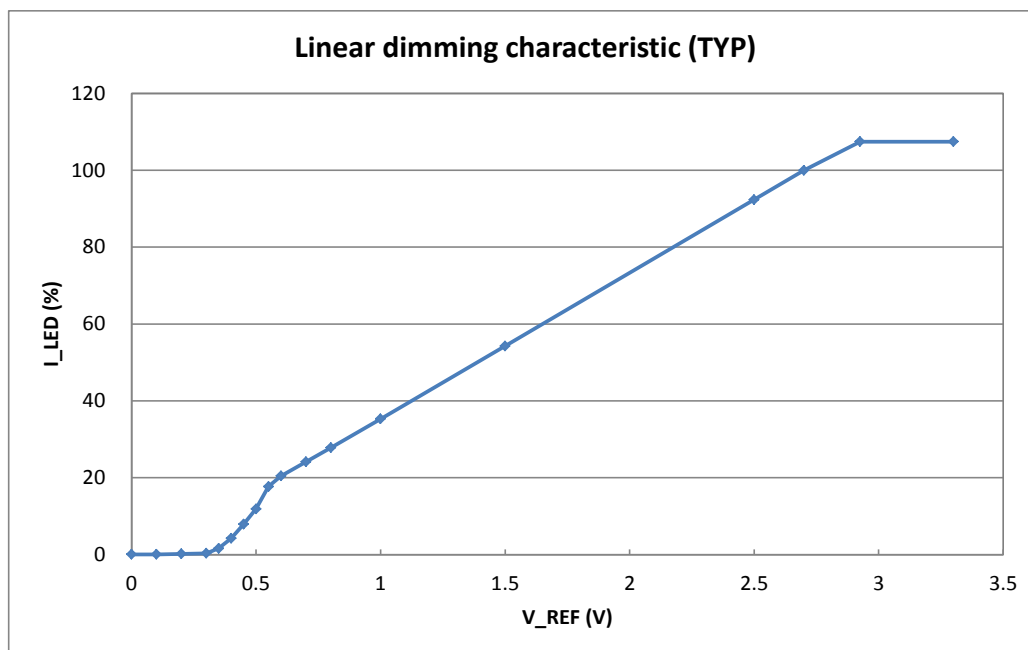

# Package Outline-Dimensions

unit : mm  
scale: 3/1

L5

JEDEC Code	-
JEITA Code	-
House Name	SOP16

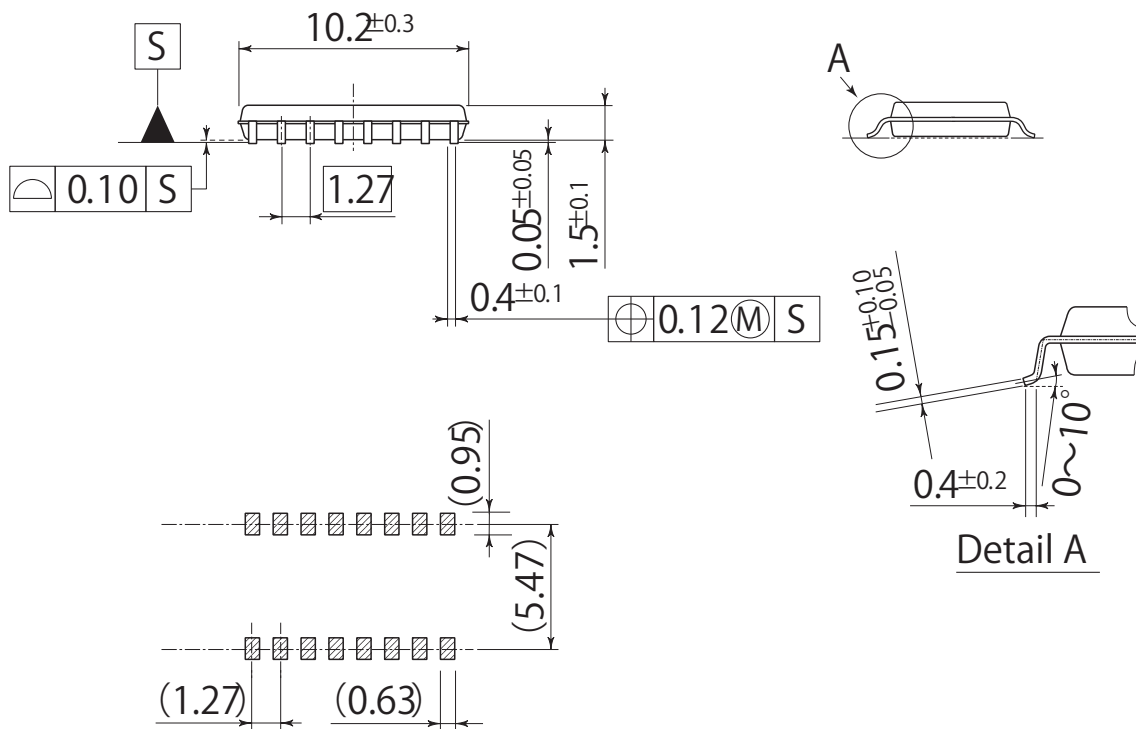
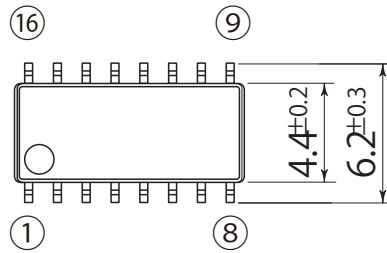

## Referential Soldering Pad

- 量産時には、適正化を図って下さい
- Optimize soldering pad to the board design and soldering condition.

- 本資料の記載内容は、改良のため予告なく変更することがあります
- ご使用にあたりましては、別途仕様書を必ずご請求下さい
- The content specified herein is subject to change for improvement without notice.
- If you wish to use any such products, please be sure to refer to the specifications.

U182(2019.02)



## Notes

1. If you wish to use any such product, please be sure to refer to the specifications issued by Shindengen.
2. All products described or contained herein are designed with a quality level intended for use in standard applications requiring an ordinary level of reliability. If these products are to be used in equipment or devices for special or specific applications requiring an extremely high grade of quality or reliability in which failures or malfunctions of products may directly affect human life or health, a local Shindengen office must be contacted in advance to confirm that the intended use of the product is appropriate. Shindengen products are grouped into the following three applications according to the quality grade.
  - 【Standard applications】  
Computers, office automation and other office equipment, communication terminals, test and measurement equipment, audio/visual equipment, amusement equipment, consumer electronics, machine tools, personal electronic equipment, industrial equipment, etc.
  - 【Special applications】  
Transportation equipment (vehicles, ships, etc.), trunk-line communication equipment, traffic signal control systems, anti-disaster/crime systems, safety equipment, medical equipment, etc.
  - 【Specific applications】  
Nuclear reactor control systems, aircraft, aerospace equipment, submarine repeaters, life support equipment and systems, etc.
3. Although Shindengen continuously endeavors to enhance the quality and reliability of its products, customers are advised to consider and take safety measures in their design, such as redundancy, fire containment and anti-failure, so that personal injury, fires, or societal damages can be prevented.
4. Please note that all information described or contained herein is subject to change without notice due to product upgrades and other reasons. When buying Shindengen products, please contact the Company's offices or distributors to obtain the latest information.
5. Shindengen shall not bear any responsibility with regards to damages or infringement of any third-party patent rights and other intellectual property rights incurred due to the use of information on this website.
6. The information and materials on this website neither warrant the use of Shindengen's or any third party's patent rights and other intellectual property rights, nor grant license to such rights.
7. In the event that any product described or contained herein falls under the category of strategic products controlled under the Foreign Exchange and Foreign Trade Control Law of Japan, exporting of such products shall require an export license from the Japanese government in accordance with the above law.
8. No reprinting or reproduction of the materials on this website, either in whole or in part, is permitted without proper authorization from Shindengen.