

Yellow GaP LED Lamps

Optoelectronic Products

MV5352 MV5353 MV5354

General Description

The MV5352, MV5353 and MV5354 are yellow light-emitting diodes encapsulated in yellow epoxy. Viewing angle can be selected from point source to wide angle. Visual light emission is in the 525 nm to 625 nm range.

High Luminous Intensity For Ambient Light Levels

Solid State — No Replacement Required

High On/Off Contrast

Flexible Pins On All Lamps

For Good Heat Sinking

For Right-Angle Bending

Fits Standard Sockets or Drilled Holes

Single Molded Body Eliminates Thermal

Cycling Problems

Low Power For IC Compatibility

MV5352 For Point Source Lamps

MV5353 For Wide Angle Lamps

MV5354 For Intermediate Dispersion Lamps

Absolute Maximum Ratings

Maximum Temperature and Humidity

Storage Temperature -55°C to +100°C

Operating Temperature -55°C to +100°C

Pin Temperature (Soldering, 5 s) 260°C

Relative Humidity at 85°C 85%

Maximum Power Dissipation

Total Dissipation at $T_A = 25^\circ\text{C}$ 105 mW

Derate Linearly from 25°C 1.14 mW/°C

Maximum Voltage and Currents

V_R Reverse Voltage 5.0 V

I_F Forward dc Current at
 $T_A = 25^\circ\text{C}$ 35 mA

I_{pk} Peak Forward Current
(1.0 μs pulse width,
0.1% duty cycle) 1.0 A

Package Outline

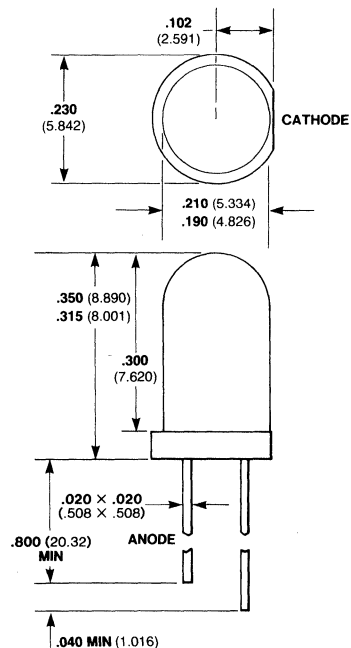

Notes

All dimensions in inches **bold** and millimeters (parentheses)
Tolerance unless specified = $\pm .015$ (0.381)

Typical Electrical Characteristics

MV5352 MV5353 MV5354

Electrical and Radiant Characteristics $T_A = 25^\circ\text{C}$

Symbol	Characteristic	Min	Typ	Max	Units	Test Conditions
V_F	Forward Voltage		2.1	3.0	V	$I_F = 20\text{ mA}$
BV_R	Reverse Breakdown Voltage	5.0	25		V	$I_R = 100\ \mu\text{A}$
I_O	Axial Luminous Intensity				mcd	$I_F = 20\text{ mA}$
	MV5352	10	45			
	MV5353	2.5	6.0			
	MV5354	3.0	10			
θ	Viewing Angle Total				degrees	$I_F = 20\text{ mA}$
	MV5352		28			
	MV5353		65			
	MV5354		24			
λ_{pk}	Peak Wavelength		585		nm	$I_F = 20\text{ mA}$

Emission Spectrum

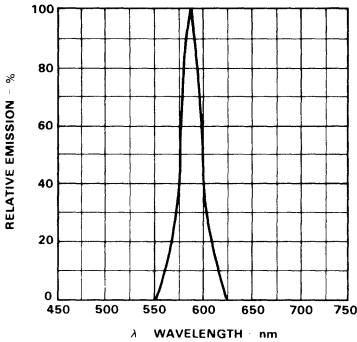

Forward Current vs Forward Voltage

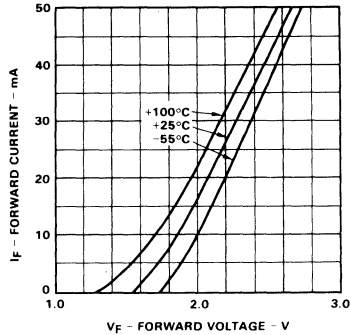

Intensity vs Forward Current

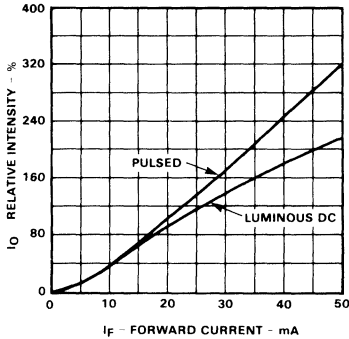

Intensity vs Viewing Angle

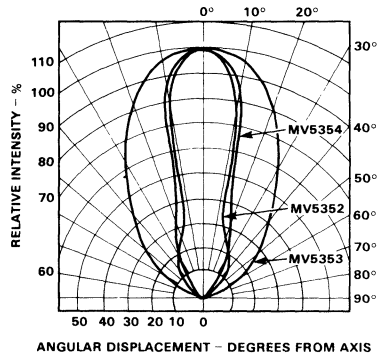

Typical Electrical Characteristic Curves

MV5352
MV5353
MV5354

Peak Wavelength vs Temperature

