

## MWCT2xx2A

Supports MWCT20D2AVLH, MWCT2012AVLH and MWCT20D2VLH

## MWCT2XX2A

The series of MWCT2xx2A is an automotive wireless power transmitter controller that integrates all required functions for Wireless Power Consortium (WPC) "Qi" compliant wireless power transmitter design. It is a safe and secure device which utilizes the DSASS security module to support on-chip Qi authentication.

To maximize the design flexibility and product differentiation, this family supports WPC's Baseline Power Profile (BPP), Extended Power Profile (EPP) and Magnetic Power Profile (MPP) in automotive/industrial/consumer power transmitter designs, using the fixed operation frequency control methods such as rail voltage control, phase shift control or duty cycle control etc. In addition, the easy-to-use NXP's FreeMASTER GUI tool has configuration, calibration and debugging functions to provide the user-friendly design experience and reduce time-to-market.

This family supports up to 2 digital demodulation modules to reduce the external components, up to 2 FSK modulation modules to support two-way communication, protection module to perform the over-voltage/current/temperature protection, FOD module to provide the protection of overheating by misplaced metallic foreign objects on each charging pad, and general I2C/SCI/SPI interfaces for external communications. It is also able to process any abnormal condition and operational status, and provides comprehensive indicator outputs for robust system design.

### Features

- Compliant with the latest version WPC Qi specification's power transmitter design
- On-chip security module supports authentication required in WPC Qi specification
- Support BPP, EPP and MPP as well as customer proprietary protocol to enable fast charging and authentication
- Support wide transmitter DC input voltage range (from 5 V to 48 V)
- Integrated digital demodulation
- Support two-way communication, transmitter to receiver by FSK and receiver to transmitter by ASK
- Support Q factor detection and calibrated power loss based Foreign Object Detection (FOD) framework
- Low standby power

- I2C/SCI/SPI interfaces
- LED for system status indication
- Over-voltage/current/temperature protection
- Software based solution to provide the design flexibility as well as product upgrade without hardware changes
- AEC-Q100 qualified and PPAP capable

### Applications

- Wireless Power Transmitters:
  - Automotive and Industrial and Consumer
  - Single coil or multi-coil
  - Single Transmitter or Multi Transmitters controlled by the same device
  - WPC's BPP, EPP and MPP compliant
  - Customer proprietary protocols and all Qi topologies supported

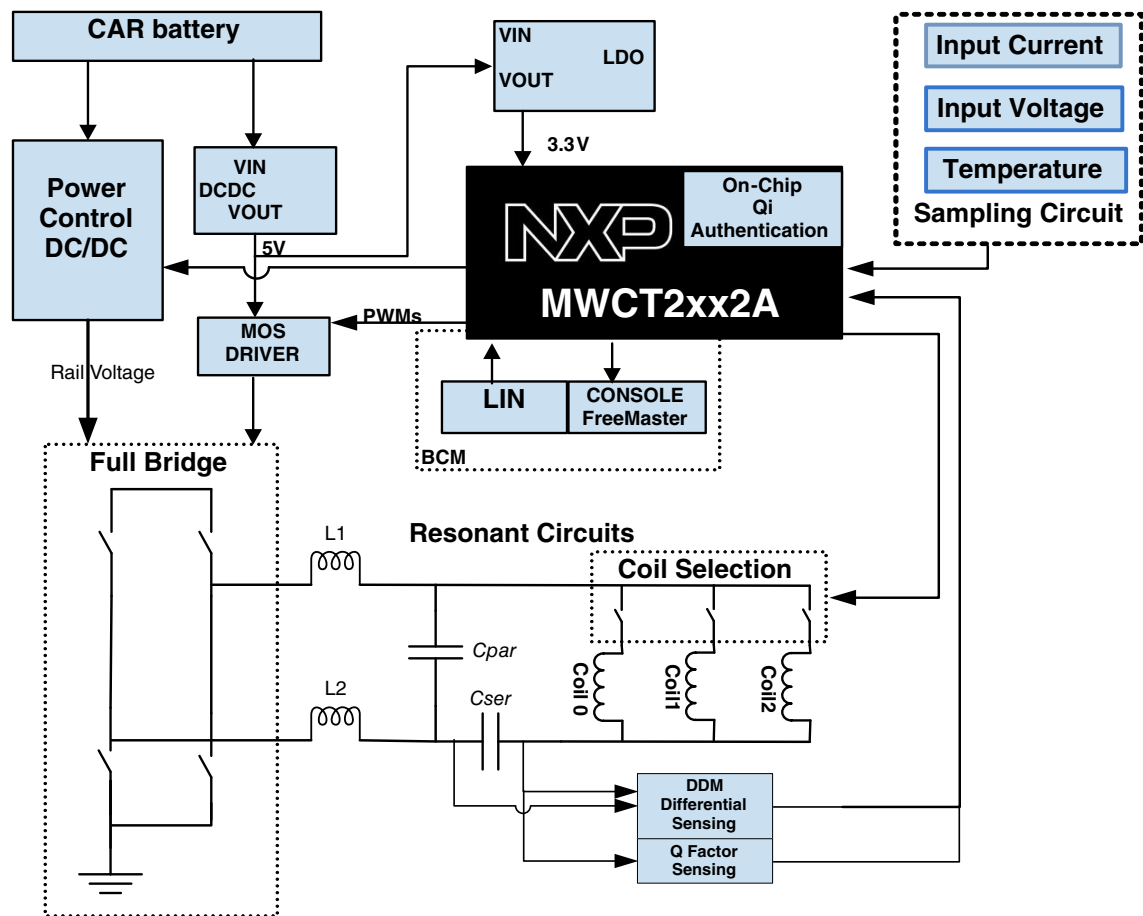

Figure 1. MP-A13 wireless charging single-transmitter system functional diagram (example)

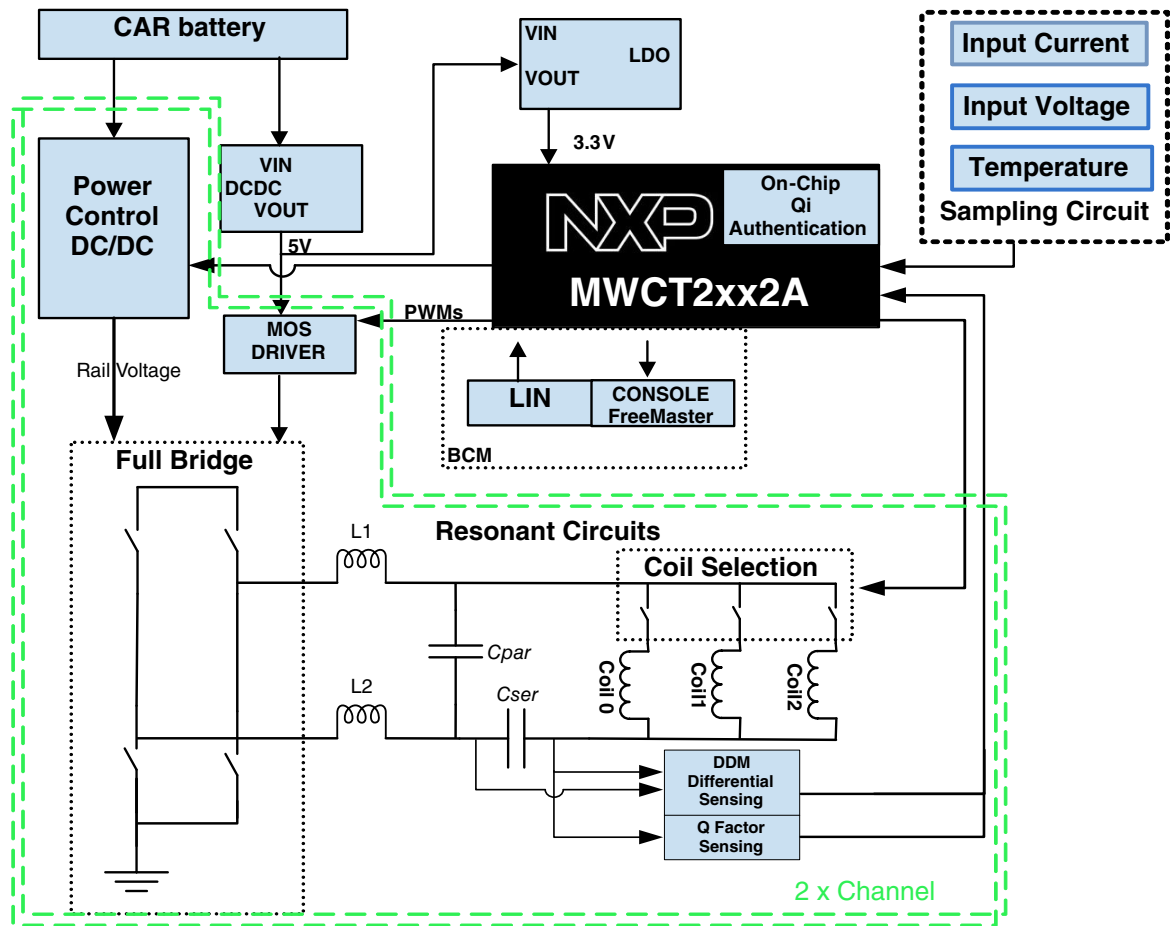
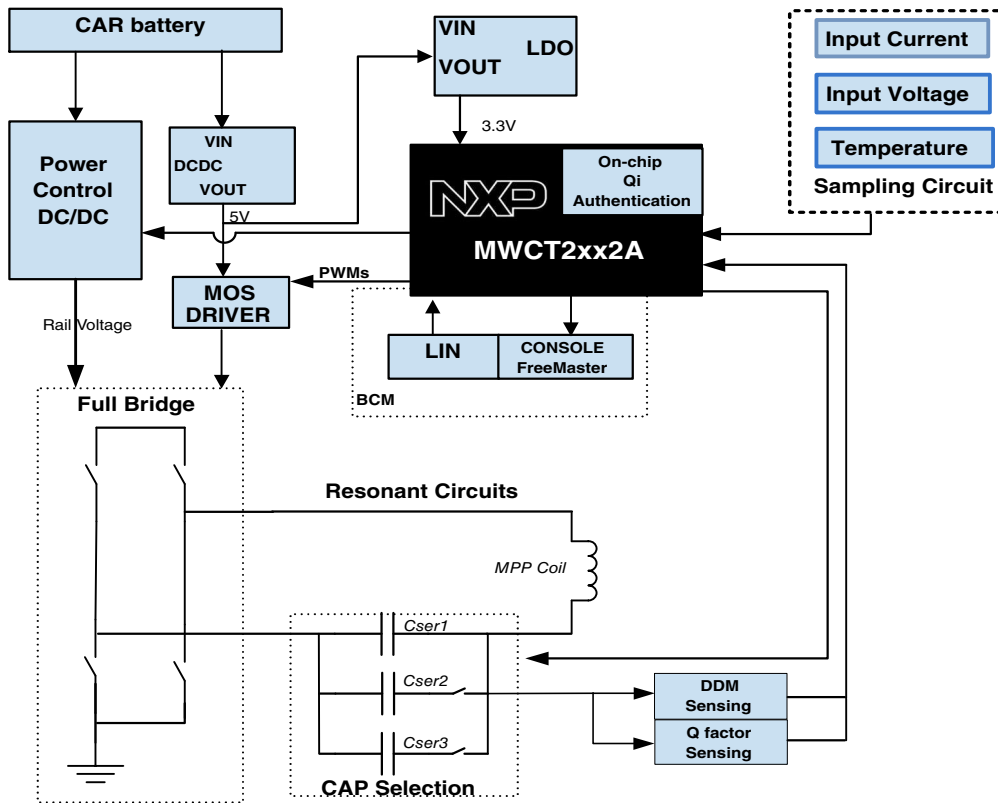

Figure 2. MP-A13 wireless charging dual-transmitter system functional diagram (example)



**Figure 3. MPP wireless charging single-transmitter system functional diagram (example)**

# Table of Contents

1	Overview.....	6	6.1	Thermal handling ratings.....	37
1.1	Product Family.....	6	6.2	Moisture handling ratings.....	37
1.2	56800EX 32-bit Digital Signal Controller (DSC) core.....	7	6.3	ESD and latch-up ratings.....	37
1.3	Operation Parameters.....	8	6.4	Voltage and current operating ratings.....	38
1.4	Interrupt Controller.....	8	7	General.....	38
1.5	Peripheral highlights.....	8	7.1	General characteristics.....	38
1.6	System Block Diagram.....	16	7.2	AC electrical characteristics.....	39
2	Signal and pin descriptions.....	18	7.3	Nonswitching electrical specifications.....	40
3	Signal groups.....	29	7.4	Switching specifications.....	45
4	Pinout.....	29	7.5	Thermal specifications.....	46
4.1	Signal Multiplexing and Pin Assignments.....	29	8	Peripheral operating requirements and behaviors.....	47
4.2	Pinout diagrams.....	31	8.1	Core modules.....	47
5	Terminology and guidelines.....	32	8.2	System modules.....	49
5.1	Definition: Operating requirement.....	32	8.3	Clock modules.....	49
5.2	Definition: Operating behavior.....	33	8.4	Memories and memory interfaces.....	52
5.3	Definition: Attribute.....	33	8.5	Analog.....	54
5.4	Definition: Rating.....	34	8.6	PWMs and timers.....	61
5.5	Result of exceeding a rating.....	34	8.7	Communication interfaces.....	62
5.6	Relationship between ratings and operating requirements.....	35	9	Design Considerations.....	67
5.7	Guidelines for ratings and operating requirements.....	35	9.1	Thermal design considerations.....	67
5.8	Definition: Typical value.....	35	9.2	Electrical design considerations.....	69
5.9	Typical value conditions.....	36	9.3	Power-on Reset design considerations.....	70
6	Ratings.....	37	10	Obtaining package dimensions.....	71
			A.1	Revision history.....	72

# 1 Overview

## 1.1 Product Family

Table 1. MWCT2xx2A Family

Feature	Part number for the series		
	20D2A	20D2	2012A
Core frequency (MHz)	100 / 50		
Flash memory (KB)	128		
RAM (KB)	20		
Boot ROM	Supports Crypto Algorithms and I2C/SCI boot		Supports I2C/SCI boot
On-Chip Authentication Support	Yes		No
Inter Module Xbar	Yes		
Event Generator	4		
Windowed Watchdog	1		
External Watchdog Monitor	1		
eDMA	4CH		
Internal OSC	8 MHz / 200 KHz		
External Crystal Oscillator	Yes (4 MHz ~ 16 MHz)		
Comparator + 8bit DAC	4		
Operational Amplifier	2		
12-bit Cyclic ADC channels	2 x 8-ch		
NanoEdge PWM: high-resolution	8-ch		
Standard PWM with Input capture	4-ch		
QTimers	4 x 16bit		
Periodic Interval Timers	2 x 32bit		
12bit DAC	1		
LPI2C (supports Full PMBus)	2		
QSCI	2		
QSPI	1		
GPIO	54		
Operating Temperature	-40°C to 105°C (V grade temperature)		
Package	64 LQFP		
AEC-Q100	Yes	No	Yes

## 1.2 56800EX 32-bit Digital Signal Controller (DSC) core

- Efficient 32-bit 56800EX Digital Signal Processor (DSP) engine with modified dual Harvard architecture:
  - Three internal address buses
  - Four internal data buses: two 32-bit primary buses, one 16-bit secondary data bus, and one 16-bit instruction bus
  - 32-bit data accesses
  - Supports concurrent instruction fetches in the same cycle, and dual data accesses in the same cycle
  - 20 addressing modes
- 162 basic instructions
- Instruction set supports both fractional arithmetic and integer arithmetic
- 32-bit internal primary data buses support 8-bit, 16-bit, and 32-bit data movement, plus addition, subtraction, and logical operations
- Single-cycle  $16 \times 16$ -bit  $\rightarrow$  32-bit and  $32 \times 32$ -bit  $\rightarrow$  64-bit multiplier-accumulator (MAC) with dual parallel moves
- 32-bit arithmetic and logic multi-bit shifter
- Four 36-bit accumulators, including extension bits
- Parallel instruction set with unique DSP addressing modes
- Hardware DO and REP loops
- Bit reverse address mode, which effectively supports DSP and Fast Fourier Transform algorithms
- Full shadowing of the register stack for zero-overhead context saves and restores: nine shadow registers correspond to nine address registers (R0, R1, R2, R3, R4, R5, N, N3, M01)
- Instruction set supports both DSP and controller functions
- Controller-style addressing modes and instructions enable compact code
- Enhanced bit manipulation instruction set
- Efficient C compiler and local variable support
- Software subroutine and interrupt stack, with the stack's depth limited only by memory
- Priority level setting for interrupt levels
- JTAG/Enhanced On-Chip Emulation (OnCE) for unobtrusive, real-time debugging that is independent of processor speed

## 1.3 Operation Parameters

- 50 MHz core frequency in normal mode, 100 MHz core frequency in fast mode.
- Operation ambient temperature:  
-40 °C to 105°C
- Single 3.3 V power supply
- Supply range:  $V_{DD} - V_{SS} = 2.7 \text{ V to } 3.6 \text{ V}$ ,  $V_{DDA} - V_{SSA} = 2.7 \text{ V to } 3.6 \text{ V}$

## 1.4 Interrupt Controller

- Five interrupt priority levels
  - Three user-programmable priority levels for each interrupt source: level 0, level 1, level 2
  - Unmaskable level 3 interrupts include illegal instruction, hardware stack overflow, misaligned data access, SWI3 instruction
  - Interrupt level 3 is highest priority and non-maskable. Its sources include:
    - Illegal instructions
    - Hardware stack overflow
    - SWI instruction
    - EOnCE interrupts
    - Misaligned data accesses
  - Lowest-priority software interrupt: level LP
- Support for nested interrupts, so that a higher priority level interrupt request can interrupt lower priority interrupt subroutine
- Masking of interrupt priority level is managed by the 56800EX core
- Two programmable fast interrupts that can be assigned to any interrupt source
- Notification to System Integration Module (SIM) to restart clock when in wait and stop states
- Ability to relocate interrupt vector table

## 1.5 Peripheral highlights

### 1.5.1 Enhanced Flex Pulse Width Modulator (eFlexPWM)

- 16 bits of resolution for center, edge-aligned, and asymmetrical PWMs
- PWMA with NanoEdge high resolution



- Fractional delay for enhanced resolution of the PWM period and edge placement
- Arbitrary PWM edge placement
- 312 ps PWM frequency and duty-cycle and deadtime resolution when NanoEdge functionality is enabled.
- PWM outputs can be configured as complementary output pairs or independent outputs
- Dedicated time-base counter with period and frequency control per submodule
- Independent top and bottom deadtime insertion for each complementary pair
- Independent control of both edges of each PWM output
- Enhanced input capture and output compare functionality on each input:
  - Channels not used for PWM generation can be used for buffered output compare functions.
  - Channels not used for PWM generation can be used for input capture functions.
  - Enhanced dual edge capture functionality
- Synchronization of submodule to external hardware (or other PWM) is supported.
- Double-buffered PWM registers
  - Integral reload rates from 1 to 16
  - Half-cycle reload capability
- Multiple output trigger events can be generated per PWM cycle via hardware.
- Support for double-switching PWM outputs
- Up to eight fault inputs can be assigned to control multiple PWM outputs
  - Programmable filters for fault inputs
- Independently programmable PWM output polarity
- Individual software control of each PWM output
- All outputs can be programmed to change simultaneously via a FORCE\_OUT event.
- PWMX pin can optionally output a third PWM signal from each submodule
- Option to supply the source for each complementary PWM signal pair from any of the following:
  - Crossbar module outputs
  - External ADC input, taking into account values set in ADC high and low limit registers
- Direct phase shift controls among each submodule
- Trigger signal can share the same load frequency as reload signal in each submodule

### 1.5.2 12-bit Analog-to-Digital Converter (Cyclic type)

- Two independent 12-bit analog-to-digital converters (ADCs):
  - 2 x 8-channel external inputs
  - Built-in x1, x2, x4 programmable gain pre-amplifier
  - Maximum ADC clock frequency up to 12.5 MHz, having period as low as 80 ns
  - Single conversion time of 10 ADC clock cycles
  - Additional conversion time of 8 ADC clock cycles
- Support of analog inputs for single-ended and differential (including unipolar differential) conversions
- Sequential and parallel scan modes. Parallel mode includes simultaneous and independent scan modes.
- Samples of each ADC have offset, limit and zero-crossing calculation supported
- ADC conversions can be synchronized by *any* module connected to the internal crossbar module, such as PWM, timer, GPIO, and comparator modules.
- Support for hardware-triggering and software-triggering conversions
- Support for a multi-triggering mode with a programmable number of conversions on each trigger
- Each ADC has ability to scan and store up to 8 conversion results.
- Current injection protection

### 1.5.3 Operational Amplifier (OPAMP)

- Capability of being configured as various types of amplifier:
  - standalone operational amplifier
  - unity gain follower (voltage follower)
  - x2, x4, x8, x16 programmable gain amplifier (PGA)
  - differential amplifier
  - low-pass filter
- 4-to-1 input multiplexer on inverting and non-inverting input
- 4 set configurations including multiplexer inputs can be managed by internal modules and synchronized with ADCs, PWMs and timers
- Operation modes: high speed mode and low power mode

### 1.5.4 12-bit Digital-to-Analog Converter

- 12-bit resolution

- Powerdown mode
- Automatic mode allows the DAC to automatically generate pre-programmed output waveforms, including square, triangle, and sawtooth waveforms (for applications like slope compensation)
- Programmable period, update rate, and range
- Output can be routed to an internal comparator, or optionally to an off-chip destination

### 1.5.5 Comparator

- Full rail-to-rail comparison range
- Support for high and low speed modes
- Selectable input source includes external pins and internal DACs
- Programmable output polarity
- 8-bit programmable DAC as a voltage reference per comparator
- Three programmable hysteresis levels
- Selectable interrupt on rising-edge, falling-edge, or toggle of a comparator output

### 1.5.6 Periodic Interrupt Timer (PIT)

- 32-bit counter with programmable count modulo
- PIT0 is master and PIT1 is slave (if synchronizing both PITs)
- The output signals of both PIT0 and PIT1 are internally connected to a peripheral crossbar module
- Can run when the CPU is in Wait/Stop modes. Can also wake up the CPU from Wait/Stop modes.
- In addition to its existing bus clock (up to 50 MHz), alternate clock sources for the counter clock are also available:
  - Crystal oscillator output
  - 8 MHz / 2 MHz internal RC output
  - On-chip low-power 200 kHz oscillator

### 1.5.7 Inter-Module Crossbar and Event Generator (EVTG) logic

- Provides generalized connections between and among on-chip peripherals: ADCs, 12-bit DAC, comparators, quad-timers, eFlexPWMs, EWM, and select I/O pins
- User-defined input/output pins for all modules connected to the crossbar
- DMA request and interrupt generation from the crossbar

## Peripheral highlights

- Write-once protection for all registers
- The EVTG module mainly includes two parts: Two AND/OR/INVERT (known simply as the AOI) modules and one configurable Flip-Flop. It supports the generation of a configurable number of EVENT signals. The inputs are from crossbar (XBAR) outputs, and the outputs feed to XBAR inputs.

### 1.5.8 Quad Timer

- Four 16-bit up/down counters, with a programmable prescaler for each counter
- Operation modes: edge count, gated count, signed count, capture, compare, PWM, signal shot, single pulse, pulse string, cascaded, quadrature decode
- Programmable input filter
- Counting start can be synchronized across counters

### 1.5.9 Queued Serial Communications Interface (QSCI) modules with LIN Slave Functionality

- Operating clock can be up to two times the CPU operating frequency
- Four-word-deep FIFOs available on both transmit and receive buffers
- Standard mark/space non-return-to-zero (NRZ) format
- 16-bit integer and 3-bit fractional baud rate selection
- Full-duplex or single-wire operation
- Programmable 8-bit or 9-bit data format
- Error detection capability
- Two receiver wakeup methods:
  - Idle line
  - Address mark
- 1/16 bit-time noise detection
- Support for Local Interconnect Network (LIN) slave operation

### 1.5.10 Queued Serial Peripheral Interface (QSPI) modules

- Maximum 25 Mbit/s baud rate
- Selectable baud rate clock sources for low baud rate communication
- Baud rate as low as the maximum Baud rate / 4096
- Full-duplex operation
- Master and slave modes
- Double-buffered operation with separate transmit and receive registers
- Four-word-deep FIFOs available on transmit and receive buffers

- Programmable length transmissions (2 bits to 16 bits)
- Programmable transmit and receive shift order (MSB or LSB as first bit transmitted)

### 1.5.11 Low Power Inter-Integrated Circuit (LPI2C)

The LPI2C supports:

- Standard, Fast, Fast+ and Ultra Fast modes are supported
- High speed mode (HS) in slave mode
- High speed mode (HS) in master mode, if SCL pin implements current source pull-up (device-specific)
- Multi-master support, including synchronization and arbitration. Multi-master means any number of master nodes can be present. Additionally, master and slave roles may be changed between messages (after a STOP is sent).
- Clock stretching: Sometimes multiple I2C nodes may be driving the lines at the same time. If any I2C node is driving a line low, then that line will be low. I2C nodes that are starting to transmit a logical one (by letting the line float high) can detect that the line is low, and thereby know that another I2C node is active at the same time.
  - When node detection is used on the SCL line, it is called *clock stretching*, and clock stretching is used as a I2C flow control mechanism for multiple slaves.
  - When node detection is used on the SDA line, it is called *arbitration*, and arbitration ensures that there is only one I2C node transmitter at a time.
- General call, 7-bit and 10-bit addressing
- Software reset, START byte and Device ID (also require software support)

The LPI2C master supports:

- Command/transmit FIFO of 4 words.
- Receive FIFO of 4 words.
- Command FIFO will wait for idle I2C bus before initiating transfer
- Command FIFO can initiate (repeated) START and STOP conditions and one or more master-receiver transfers
- STOP condition can be generated from command FIFO, or generated automatically when the transmit FIFO is empty
- Host request input to control the start time of an I2C bus transfer
- Flexible receive data match can generate interrupt on data match and/or discard unwanted data

## Peripheral highlights

- Flag and optional interrupt to signal Repeated START condition, STOP condition, loss of arbitration, unexpected NACK, and command word errors
- Supports configurable bus idle timeout and pin-stuck-low timeout

The LPI2C slave supports:

- Separate I2C slave registers to minimize software overhead because of master/slave switching
- Support for 7-bit or 10-bit addressing, address range, SMBus alert and general call address
- Transmit data register that supports interrupt or DMA requests
- Receive data register that supports interrupt or DMA requests
- Software-controllable ACK or NACK, with optional clock stretching on ACK/NACK bit
- Configurable clock stretching, to avoid transmit FIFO underrun and receive FIFO overrun errors
- Flag and optional interrupt at end of packet, STOP condition, or bit error detection

### 1.5.12 Windowed Computer Operating Properly (COP) watchdog

- Programmable windowed timeout period
- Support for operation in all power modes: run mode, wait mode, stop mode
- Causes loss of reference reset 128 cycles after loss of reference clock to the PLL is detected
- Selectable reference clock source in support of EN60730 and IEC61508
- Selectable clock sources:
  - External crystal oscillator
  - On-chip low-power 200 kHz oscillator
  - System bus clock (IPBus clock) up to 50 MHz
  - 8 MHz / 2 MHz IRC
- Support for interrupt generation

### 1.5.13 External Watchdog Monitor (EWM)

- Monitors external circuit as well as the software flow
- Programmable timeout period
- Interrupt capability prior to timeout
- Independent output (EWM\_OUT\_b) that places external circuit (but not CPU and peripheral) in a safe mode when EWM timeout occurs
- Selectable reference clock source in support of EN60730 and IEC61508

- Wait mode and Stop mode operation is not supported.
- Selectable clock sources:
  - External crystal oscillator
  - On-chip low-power 200 kHz oscillator
  - System bus clock (IPBus clock) up to 50 MHz
  - 8 MHz / 2 MHz IRC

#### 1.5.14 Power supervisor

- Power-on reset (POR) is released after  $V_{DD} > 2.7$  V during supply is ramped up; CPU, peripherals, and JTAG/EOnCE controllers exit RESET state
- Brownout reset ( $V_{DD} < 2.0$  V)
- Critical warn low-voltage interrupt (LVI 2.2 V)
- Peripheral low-voltage warning interrupt (LVI 2.7 V)

#### 1.5.15 Phase-locked loop

- Output frequency range is optimized from 200 MHz to 550 MHz
- Input reference clock frequency: 8 MHz to 16 MHz
- Detection of loss of lock and loss of reference clock
- Ability to power down

#### 1.5.16 Clock sources

##### 1.5.16.1 On-chip oscillators

- Tunable 8 MHz RC oscillator with 2 MHz at standby mode
- 200 kHz low frequency clock as secondary clock source for COP, EWM, PIT

##### 1.5.16.2 Crystal oscillator

- Support for both high ESR crystal oscillator (ESR greater than 100  $\Omega$ ) and ceramic resonator
- Operating frequency: 4–16 MHz

#### 1.5.17 Cyclic Redundancy Check (CRC) generator

- Hardware 16/32-bit CRC generator
- High-speed hardware CRC calculation

## Clock sources

- Programmable initial seed value
- Programmable 16/32-bit polynomial
- Error detection for all single, double, odd, and most multi-bit errors
- Option to transpose input data or output data (CRC result) bitwise or bitwise,<sup>1</sup> which is required for certain CRC standards
- Option for inversion of final CRC result

### 1.5.18 General Purpose I/O (GPIO)

- Individual control of peripheral mode or GPIO mode for each pin
- Programmable push-pull or open drain output
- Configurable pullup or pulldown on all input pins
- All pins (except JTAG, RESET\_B ) default to be GPIO inputs
- Controllable output slew rate

## 1.6 System Block Diagram

### NOTE

The following figure shows the maximum memory configurations supported.

1. A bitwise transposition is not possible when accessing the CRC data register via 8-bit accesses. In this case, user software must perform the bitwise transposition.



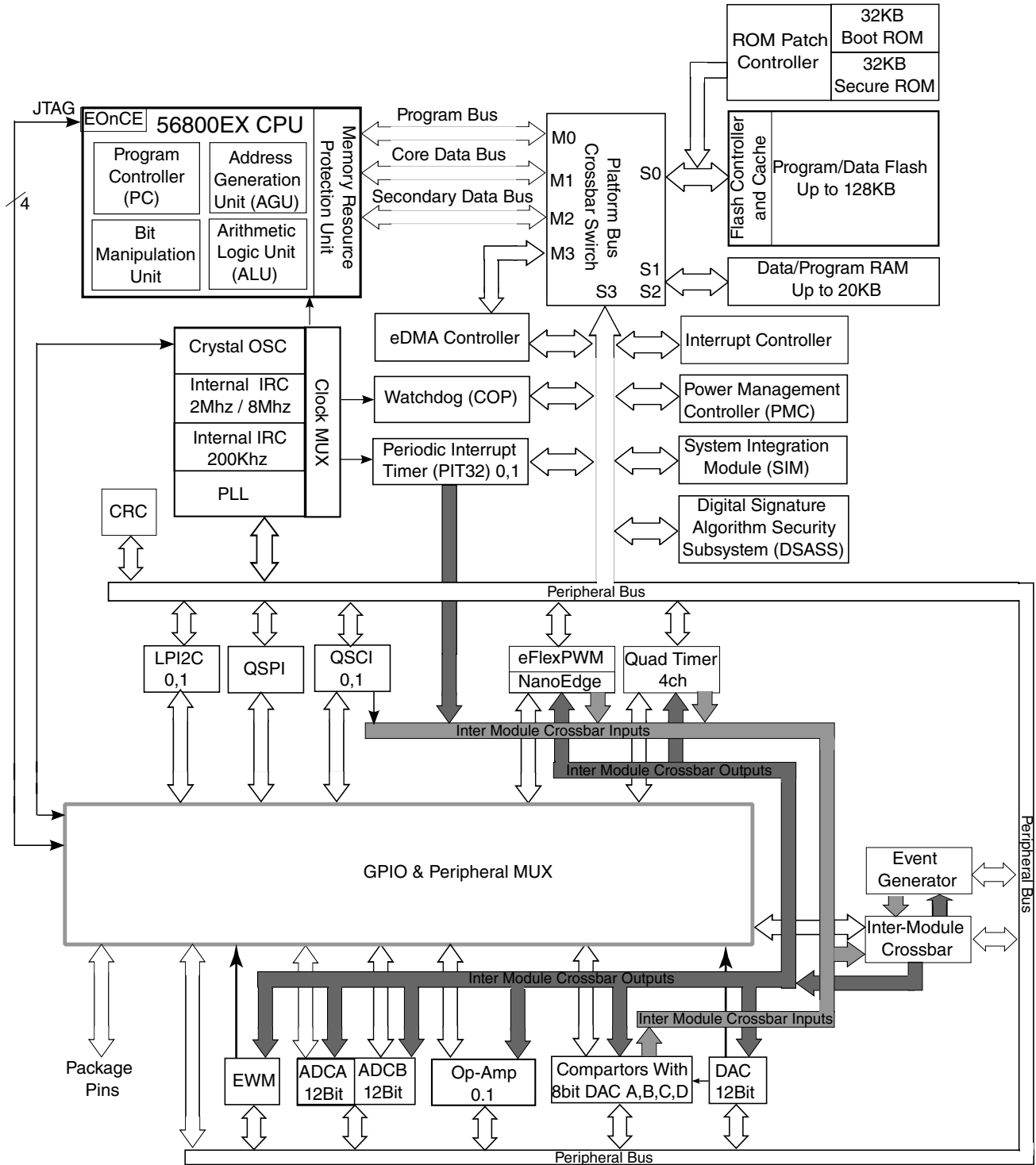

Figure 4. System block diagram

## 2 Signal and pin descriptions

After reset, each pin is configured for its primary function (listed first). Any alternative functionality, shown in parentheses, must be programmed through the GPIO module peripheral enable registers (GPIOx\_PER) and the SIM module GPIO peripheral select (GPSx) registers. All GPIO ports can be individually programmed as an input or output (using bit manipulation).

For this device, which is 64-pin LQFP package, the following table lists detailed description of signals.

**Table 2. Signal descriptions**

Signal Name	64 LQFP	State During Reset	Type	Signal Description
V <sub>DD</sub>	29	Supply	Supply	I/O Power — Supplies 3.3 V power to the chip I/O interface.
	44			
	60			
V <sub>SS</sub>	30	Supply	Supply	I/O Ground — Provide ground for the device I/O interface.
	43			
	61			
V <sub>DDA</sub>	22	Supply	Supply	Analog Power — Supplies 3.3 V power to the analog modules. It must be connected to a clean analog power supply.
V <sub>SSA</sub>	23	Supply	Supply	Analog Ground — Supplies an analog ground to the analog modules. It must be connected to a clean power supply.
V <sub>CAP</sub>	26	On-chip regulator output	On-chip regulator output	Connect a 2.2 $\mu$ F or greater bypass capacitor between this pin and V <sub>SS</sub> to stabilize the core voltage regulator output required for proper device operation. <b>NOTE:</b> The total bypass capacitor value between all V <sub>CAP</sub> pins and V <sub>SS</sub> recommends between 4.0 $\mu$ F ~ 5.0 $\mu$ F.
	57			
TDI	64	Input, internal pullup enabled	Input	Test Data Input — Provides a serial input data stream to the JTAG/EOnCE port. It is sampled on the rising edge of TCK and has an internal pullup resistor. After reset, the default state is TDI.
(GPIOD0)			Input/Output	GPIO Port D0.
TDO	62	Output	Output	Test Data Output — This tri-state-able pin provides a serial output data stream from the JTAG/EOnCE port. It is driven in the shift-IR and shift-DR controller states, and it changes on the falling edge of TCK. After reset, the default state is TDO.
(GPIOD1)			Input/Output	GPIO Port D1.

*Table continues on the next page...*

Table 2. Signal descriptions (continued)

Signal Name	64 LQFP	State During Reset	Type	Signal Description
<b>TCK</b>	1	Input, internal pulldown enabled	Input	Test Clock Input — This input pin provides a gated clock to synchronize the test logic and shift serial data to the JTAG/EOnCE port. The pin is connected internally to a pulldown resistor. A Schmitt-trigger input is used for noise immunity. After reset, the default state is TCK.
(GPIOD2)			Input/ Output	GPIO Port D2.
<b>TMS</b>	63	Input, internal pullup enabled	Input	Test Mode Select Input — Used to sequence the JTAG TAP controller state machine. It is sampled on the rising edge of TCK and has an internal pullup resistor. After reset, the default state is TMS.  <b>NOTE:</b> Always tie the TMS pin to V <sub>DD</sub> through a 2.2 kΩ resistor if need to keep on-board debug capability. Otherwise, directly tie to V <sub>DD</sub> . Except being configured as GPIO.
(GPIOD3)			Input/ Output	GPIO Port D3.
<b>RESET</b>	2	Input, internal pullup enabled	Input	Reset — A direct hardware reset on the processor. When RESET is asserted low, the device is initialized and placed in the reset state. A Schmitt-trigger input is used for noise immunity. The internal reset signal is deasserted synchronously with the internal clocks after a fixed number of internal clocks. After reset, the default state is RESET. Recommended a capacitor of 0.1 μF for filtering noise and up to 22 μF for time delay if required.
(GPIOD4)			Input/ Open- drain Output	GPIO Port D4 — Can be individually programmed as an input or open-drain output pin. RESET functionality is disabled in this mode and the device can be reset only through Power-On Reset (POR), COP reset, or software reset.
<b>GPIOA0</b>	13	Input	Input/ Output	GPIO Port A0 — After reset, the default state is GPIOA0.
(ANA0 & CMPA_IN3 & OPAMPA_IN3)			Input	ANA0 — ADCA input channel 0. CMPA_IN3 — Analog comparator A input 3 OPAMPA_IN3 — Operational amplifier A input 3  When used as an analog input, the signal goes to ANA0 and CMPA_IN3 and OPAMPA_IN3. <sup>1</sup>
(CMPC_O)			Output	Analog comparator C output.
<b>GPIOA1</b>	14	Input	Input/ Output	GPIO Port A1 — After reset, the default state is GPIOA1.
(ANA1 & CMPA_IN0 &			Input	ANA1 — ADCA input channel 1. CMPA_IN0 — Analog comparator A input 0. OPAMPA_IN0 — Operational amplifier A input 0.

Table continues on the next page...

Table 2. Signal descriptions (continued)

Signal Name	64 LQFP	State During Reset	Type	Signal Description
OPAMPA_IN0)				When used as an analog input, the signal goes to ANA1 and CMPA_IN0 and OPAMPA_IN0. <sup>1</sup>
<b>GPIOA2</b>	15	Input	Input/ Output	GPIO Port A2 — After reset, the default state is GPIOA2.
(ANA2 & VREFHA & CMPA_IN1 & OPAMPA_IN1)			Input	ANA2 — ADCA input channel 2. VREFHA — ADCA analog reference high. CMPA_IN1 — Analog comparator A input 1. OPAMPA_IN1 — Operational amplifier A input 1. When used as an analog input, the signal goes to ANA2 (or VREFHA) and CMPA_IN1 and OPAMPA_IN1. <sup>1</sup> <b>NOTE:</b> ADC input can be configured as either ANA2 or VREFHA in the ADC Calibration Register.
<b>GPIOA3</b>	16	Input	Input/ Output	GPIO Port A3 — After reset, the default state is GPIOA3.
(ANA3 & VREFLA & CMPA_IN2 & OPAMPA_IN2)			Input	ANA3 — ADCA input channel 3. VREFLA — ADCA analog reference low. CMPA_IN2 — Analog comparator A input 2. OPAMPA_IN2 — Operational amplifier A input 2. When used as an analog input, the signal goes to ANA3 (or VREFLA) and CMPA_IN2 and OPAMPA_IN2. <sup>1</sup> <b>NOTE:</b> ADC input can be configured as either ANA3 or VREFLA in the ADC Calibration Register.
<b>GPIOA4</b>	12	Input	Input/ Output	GPIO Port A4 — After reset, the default state is GPIOA4.
(ANA4 & CMPD_IN0)			Input	ANA4 — ADCA input channel 4. CMPD_IN0 — Analog comparator D input 0. When used as an analog input, the signal goes to ANA4 and CMPD_IN0. <sup>1</sup>
<b>GPIOA5</b>	11	Input	Input/ Output	GPIO Port A5 — After reset, the default state is GPIOA5.
(ANA5 & CMPD_IN1)			Input	ANA5 — ADCA input channel 5. CMPD_IN1 — Analog comparator D input 1. When used as an analog input, the signal goes to ANA5 and CMPD_IN1. <sup>1</sup>
<b>GPIOA6</b>	10	Input	Input/ Output	GPIO Port A6 — After reset, the default state is GPIOA6.
(ANA6 & CMPD_IN2)			Input	ANA6 — ADCA input channel 6. CMPD_IN2 — Analog comparator D input 2. When used as an analog input, the signal goes to ANA6 and CMPD_IN2. <sup>1</sup>

Table continues on the next page...

Table 2. Signal descriptions (continued)

Signal Name	64 LQFP	State During Reset	Type	Signal Description
<b>GPIOA7</b>	9	Input	Input/Output	GPIO Port A7 — After reset, the default state is GPIOA7.
(ANA7 & CMPD_IN3)			Input	ANA7 — ADCA input channel 7. CMPD_IN3 — Analog comparator D input 3. When used as an analog input, the signal goes to ANA7 and CMPD_IN3. <sup>1</sup>
<b>GPIOB0</b>	24	Input	Input/Output	GPIO Port B0 — After reset, the default state is GPIOB0.
(ANB0 & CMPB_IN3 & OPAMPB_IN3)			Input	ANB0 — ADCB input channel 0. CMPB_IN3 — Analog comparator B input 3. OPAMPB_IN3 — Operational amplifier B input 3. When used as an analog input, the signal goes to ANB0 and CMPB_IN3 and OPAMPB_IN3. <sup>1</sup>
<b>GPIOB1</b>	25	Input	Input/Output	GPIO Port B1 — After reset, the default state is GPIOB1.
(ANB1 & CMPB_IN0 & OPAMPB_IN0)			Input	ANB1 — ADCB input channel 1. CMPB_IN0 — Analog comparator B input 0. OPAMPB_IN0 — Operational amplifier B input 0. When used as an analog input, the signal goes to ANB1 and CMPB_IN0 and OPAMPB_IN0. <sup>1</sup>
<b>GPIOB2</b>	27	Input	Input/Output	GPIO Port B2 — After reset, the default state is GPIOB2.
(ANB2 & VREFHB & CMPC_IN3)			Input	ANB2 — ADCB input channel 2. VREFHB — ADCB analog reference high. CMPC_IN3 — Analog comparator C input 3. When used as an analog input, the signal goes to ANB2 (or VREFHB) and CMPC_IN3. <sup>1</sup> <b>NOTE:</b> ADC input can be configured as either ANB2 or VREFHB in the ADC Calibration Register.
<b>GPIOB3</b>	28	Input	Input/Output	GPIO Port B3 — After reset, the default state is GPIOB3.
(ANB3 & VREFLB & CMPC_IN0)			Input	ANB3 — ADCB input channel 3. VREFLB — ADCB analog reference low. CMPC_IN0 — Analog comparator C input 0. When used as an analog input, the signal goes to ANB3 (or VREFHB) and CMPC_IN0. <sup>1</sup> <b>NOTE:</b> ADC input can be configured as either ANB3 or VREFLB in the ADC Calibration Register.

Table continues on the next page...

**Table 2. Signal descriptions (continued)**

Signal Name	64 LQFP	State During Reset	Type	Signal Description
<b>GPIOB4</b>	21	Input	Input/Output	GPIO Port B4 — After reset, the default state is GPIOB4.
(ANB4 & CMPC_IN1)			Input	ANB4 — ADCB input channel 4. CMPC_IN1 — Analog comparator C input 1. When used as an analog input, the signal goes to ANB4 and CMPC_IN1. <sup>1</sup>
<b>GPIOB5</b>	20	Input	Input/Output	GPIO Port B5 — After reset, the default state is GPIOB5.
(ANB5 & CMPC_IN2)			Input	ANB5 — ADCB input channel 5. CMPC_IN2 — Analog comparator C input 2. When used as an analog input, the signal goes to ANB5 and CMPC_IN2. <sup>1</sup>
<b>GPIOB6</b>	19	Input	Input/Output	GPIO Port B6 — After reset, the default state is GPIOB6.
(ANB6 & CMPB_IN1 & OPAMPB_IN1)			Input	ANB6 — ADCB input channel 6. CMPB_IN1 — Analog comparator B input 1. OPAMPB_IN1 — Operational amplifier B input 1. When used as an analog input, the signal goes to ANB6 and CMPB_IN1 and OPAMPB_IN1. <sup>1</sup>
<b>GPIOB7</b>	17	Input	Input/Output	GPIO Port B7 — After reset, the default state is GPIOB7.
(ANB7 & CMPB_IN2 & OPAMPB_IN2)			Input	ANB7 — ADCB input channel 7. CMPB_IN2 — Analog comparator B input 2. OPAMPB_IN2 — Operational amplifier B input 2. When used as an analog input, the signal goes to ANB7 and CMPB_IN2 and OPAMPB_IN2. <sup>1</sup>
<b>GPIOC0</b>	3	Input	Input/Output	GPIO Port C0 — After reset, the default state is GPIOC0.
(EXTAL)			Input	External crystal oscillator input (EXTAL) connects the internal crystal oscillator input to an external crystal or ceramic resonator.
(CLKIN0)			Input	External clock input 0 to OCCS.  <b>NOTE:</b> If this pin is selected as the device's external clock input, then both SIM_GPSCl[C0] bit in SIM and OSCtl1[EXT_SEL] bit in OCCS must be set. The crystal oscillator should be powered down.
<b>GPIOC1</b>	4	Input	Input/Output	GPIO Port C1 — After reset, the default state is GPIOC1.

Table continues on the next page...

Table 2. Signal descriptions (continued)

Signal Name	64 LQFP	State During Reset	Type	Signal Description
(XTAL)			Output	External crystal oscillator output (XTAL) connects the internal crystal oscillator output to an external crystal or ceramic resonator.
<b>GPIOC2</b>	5	Input	Input/ Output	GPIO Port C2 — After reset, the default state is GPIOC2.
(TXD0)			Output	SCI0 transmit data output or transmit/receive in single wire operation.
(XB_OUT11)			Output	Crossbar module output 11.
(XB_IN2)			Input	Crossbar module input 2.
(CLKO0)			Output	Buffered clock output 0.  <b>NOTE:</b> The clock source is selected by SIM_CLKOUT[CLKOSEL0] bits in SIM.
<b>GPIOC3</b>	7	Input	Input/ Output	GPIO Port C3 — After reset, the default state is GPIOC3.
(TA0)			Input/ Output	Quad timer channel 0 input/output.
(CMPA_O)			Output	Analog comparator A output.
(RXD0)			Input	SCI0 receive data input.
(CLKIN1)			Input	External clock input 1 to OCCS.  <b>NOTE:</b> If this pin is selected as device's external clock input, then both SIM_GPSCL[C3] bits in SIM and OSCTL1[EXT_SEL] bit in OCCS must be set.
<b>GPIOC4</b>	8	Input	Input/ Output	GPIO Port C4 — After reset, the default state is GPIOC4.
(TA1)			Input/ Output	Quad timer channel 1 input/output.
(CMPB_O)			Output	Analog comparator B output.
(XB_IN8)			Input	Crossbar module input 8.
(OPAMPA_OUT)			Output	Operational amplifier A output.
<b>GPIOC5</b>	18	Input	Input/ Output	GPIO Port C5 — After reset, the default state is GPIOC5.
(DACA_O)			Output	12-bit digital-to-analog output.
(XB_IN7)			Input	Crossbar module input 7.
<b>GPIOC6</b>	31	Input	Input/ Output	GPIO Port C6 — After reset, the default state is GPIOC6.
(TA2)			Input/ Output	Quad timer channel 2 input/output.
(XB_IN3)			Input	Crossbar module input 3.
(CMP_REF)			Input	Input 5 of analog comparator A and B and C and D.

Table continues on the next page...

Table 2. Signal descriptions (continued)

Signal Name	64 LQFP	State During Reset	Type	Signal Description
(SS0_B)			Input/Output	SPI0 slave select.
<b>GPIOC7</b>	32	Input	Input/Output	GPIO Port C7 — After reset, the default state is GPIOC7.
(SS0_B)			Input/Output	SPI0 slave select.
(TXD0)			Output	SCI0 transmit data output or transmit/receive in single wire operation.
(XB_IN8)			Input	Crossbar module input 8.
(XB_OUT6)			Output	Crossbar module output 6.
<b>GPIOC8</b>			33	Input
(MISO0)	Input/Output	SPI0 master in/slave out.		
(RXD0)	Input	SCI0 receive data input.		
(XB_IN9)	Input	Crossbar module input 9.		
<b>GPIOC9</b>	34	Input		
(SCLK0)			Input/Output	SPI0 serial clock.
(XB_IN4)			Input	Crossbar module input 4.
(TXD0)			Output	SCI0 transmit data output or transmit/receive in single wire operation.
(XB_OUT8)			Output	Crossbar module output 8.
<b>GPIOC10</b>			35	Input
(MOSI0)	Input/Output	SPI0 master out/slave.		
(XB_IN5)	Input	Crossbar module input 5.		
(MISO0)	Input/Output	SPI0 master in/slave out.		
(XB_OUT9)	Output	Crossbar module output 9.		
<b>GPIOC11</b>	37	Input		
(LP_SCLS0)			Output	I <sup>2</sup> C0 secondary serial clock line. <b>NOTE:</b> In 4-wire mode, this is the I <sup>2</sup> C slave SCL output for voltage level shift.
(LP_SCL1)			Input/Open-drain Output	I <sup>2</sup> C1 serial clock line. <b>NOTE:</b> In 4-wire mode, this is the I <sup>2</sup> C slave SCL input.

Table continues on the next page...



Table 2. Signal descriptions (continued)

Signal Name	64 LQFP	State During Reset	Type	Signal Description
(TXD1)			Output	SCI1 transmit data output or transmit/receive in single wire operation.
(PWMA_0X)			Output	PWM submodule 0, output X or input capture X.
<b>GPIOC12</b>	38	Input	Input/Output	GPIO Port C12 — After reset, the default state is GPIOC12.
(LP_SDAS0)			Output	I <sup>2</sup> C0 secondary serial data line. <b>NOTE:</b> In 4-wire mode, this is the I <sup>2</sup> C slave SDA output for voltage level shift.
(LP_SDA1)			Input/ Open-drain Output	I <sup>2</sup> C1 serial data line <b>NOTE:</b> In 4-wire mode, this is the I <sup>2</sup> C slave SDA input.
(RXD1)			Input	SCI1 receive data input
(PWMA_1X)			Output	PWM submodule 1, output X or input capture X.
<b>GPIOC13</b>			49	Input
(TA3)	Input/Output	Quad timer channel 3 input/output.		
(XB_IN6)	Input	Crossbar module input 6.		
(EWM_OUT_B)	Output	External Watchdog Module output.		
<b>GPIOC14</b>	55	Input	Input/Output	GPIO Port C14 — After reset, the default state is GPIOC14.
(LP_SDA0)			Input/ Open-drain Output	I <sup>2</sup> C0 serial data line <b>NOTE:</b> In 4-wire mode, this is the I <sup>2</sup> C slave SDA input.
(XB_OUT4)			Output	Crossbar module output 4.
(PWMA_FAULT4)			Input	PWM Fault input 4 for disabling selected PWM outputs.
<b>GPIOC15</b>	56	Input	Input/Output	GPIO Port C15: After reset, the default state is GPIOC15.
(LP_SCL0)			Input/ Open-drain Output	I <sup>2</sup> C0 serial clock line <b>NOTE:</b> In 4-wire mode, this is the I <sup>2</sup> C slave SCL input.
(XB_OUT5)			Output	Crossbar module output 5.
(PWMA_FAULT5)			Input	PWM Fault input 5 for disabling selected PWM outputs.
<b>GPIOE0</b>	45	Input	Input/Output	GPIO Port E0 — After reset, the default state is GPIOE0.
(PWMA_0B)			Input/Output	PWM submodule 0, high resolution output B or input capture B.
XB_OUT4			Output	Crossbar module output 4.

Table continues on the next page...

**Table 2. Signal descriptions (continued)**

Signal Name	64 LQFP	State During Reset	Type	Signal Description
<b>GPIOE1</b>	46	Input	Input/Output	GPIO Port E1 — After reset, the default state is GPIOE1.
(PWMA_0A)			Input/Output	PWM submodule 0, high resolution output A or input capture A.
(XB_OUT5)			Output	Crossbar module output 5.
<b>GPIOE2</b>	47	Input	Input/Output	GPIO Port E2 — After reset, the default state is GPIOE2.
(PWMA_1B)			Input/Output	PWM submodule 1, high resolution output B or input capture B.
XB_OUT6			Output	Crossbar module output 6.
<b>GPIOE3</b>	48	Input	Input/Output	GPIO Port E3 — After reset, the default state is GPIOE3.
(PWMA_1A)			Input/Output	PWM submodule 1, high resolution output A or input capture A.
(XB_OUT7)			Output	Crossbar module output 7.
<b>GPIOE4</b>	51	Input	Input/Output	GPIO Port E4 — After reset, the default state is GPIOE4.
(PWMA_2B)			Input/Output	PWM submodule 2, high resolution output B or input capture B.
(XB_IN2)			Input	Crossbar module input 2
(LP_SCL1)			Input/ Open-drain Output	I <sup>2</sup> C1 serial clock line <b>NOTE:</b> In 4-wire mode, this is the I <sup>2</sup> C slave SCL input.
(XB_OUT8)			Output	Crossbar module output 8.
<b>GPIOE5</b>	52	Input	Input/Output	GPIO Port E5 — After reset, the default state is GPIOE5.
(PWMA_2A)			Input/Output	PWM submodule 2, high resolution output A or input capture A
(XB_IN3)			Input	Crossbar module input 3.
(LP_SDA1)			Input/ Open-drain Output	I <sup>2</sup> C1 serial data line <b>NOTE:</b> In 4-wire mode, this is the I <sup>2</sup> C slave SDA input.
(XB_OUT9)			Output	Crossbar module output 9.
<b>GPIOE6</b>	53	Input	Input/Output	GPIO Port E6 — After reset, the default state is GPIOE6.
(PWMA_3B)			Input/Output	PWM submodule 3, high resolution output B or input capture B.
(XB_IN4)			Input	Crossbar module input 4
(XB_OUT10)			Output	Crossbar module output 10.

Table continues on the next page...

Table 2. Signal descriptions (continued)

Signal Name	64 LQFP	State During Reset	Type	Signal Description
<b>GPIOE7</b>	54	Input	Input/Output	GPIO Port E7 — After reset, the default state is GPIOE7.
(PWMA_3A)			Input/Output	PWM ,submodule 3, high resolution output A or input capture A.
(XB_IN5)			Input	Crossbar module input 5.
(XB_OUT11)			Output	Crossbar module output 11.
<b>GPIOF0</b>	36	Input	Input/Output	GPIO Port F0 — After reset, the default state is GPIOF0.
(XB_IN6)			Input	Crossbar module input 6
(OPAMPB_OUT)			Output	Operational amplifier B output.
<b>GPIOF1</b>	50	Input	Input/Output	GPIO Port F1 — After reset, the default state is GPIOF1.
(CLKO1)			Output	Buffered clock output 1.  <b>NOTE:</b> The clock source is selected by SIM_CLKOUT[CLKOSEL1] bits in SIM.
(XB_IN7)			Input	Crossbar module input 7.
(CMPD_O)			Output	Analog comparator D output.
<b>GPIOF2</b>	39	Input	Input/Output	GPIO Port F2 — After reset, the default state is GPIOF2.
(LP_SCL1)			Input/ Open-drain Output	I <sup>2</sup> C1 serial clock line <b>NOTE:</b> In 4-wire mode, this is the I <sup>2</sup> C slave SCL input.
(XB_OUT6)			Output	Crossbar module output 6
(LP_SDA0)			Input/ Open-drain Output	I <sup>2</sup> C0 serial data line. <b>NOTE:</b> In 4-wire mode, this is the I <sup>2</sup> C slave SDA input.
<b>GPIOF3</b>	40	Input	Input/Output	GPIO Port F3 — After reset, the default state is GPIOF3.
(LP_SDA1)			Input/ Open-drain Output	I <sup>2</sup> C1 serial data line. <b>NOTE:</b> In 4-wire mode, this is the I <sup>2</sup> C slave SDA input.
(XB_OUT7)			Output	Crossbar module output 7
(LP_SCL0)			Input/ Output	I <sup>2</sup> C0 serial clock line <b>NOTE:</b> In 4-wire mode, this is the I <sup>2</sup> C slave SCL input.
<b>GPIOF4</b>	41	Input	Input/Output	GPIO Port F4 — After reset, the default state is GPIOF4.
(TXD1)			Output	SCI1 transmit data output or transmit/receive in single wire operation

Table continues on the next page...

Table 2. Signal descriptions (continued)

Signal Name	64 LQFP	State During Reset	Type	Signal Description
(XB_OUT8)			Output	Crossbar module output 8
(PWMA_0X)			Input/ Output	PWM submodule 0, output X or input capture X.
(PWMA_FAULT6)			Input	PWM Fault input 6 for disabling selected PWM outputs.
<b>GPIOF5</b>	42	Input	Input/ Output	GPIO Port F5 — After reset, the default state is GPIOF5.
(RXD1)			Input	SCI1 receive data input.
(XB_OUT9)			Output	Crossbar module output 9.
(PWMA_1X)			Input/ Output	PWM submodule 1, output X or input capture X.
(PWMA_FAULT7)			Input	PWM Fault input 7 for disabling selected PWM outputs.
<b>GPIOF6</b>	58	Input	Input/ Output	GPIO Port F6 — After reset, the default state is GPIOF6.
(PWMA_3X)			Input/ Output	PWM submodule 3, output X or input capture X.
LP_SCLS1			Output	I <sup>2</sup> C1 secondary serial clock line. <b>NOTE:</b> In 4-wire mode, this is the I <sup>2</sup> C slave SCL output for voltage level shift.
(XB_IN2)			Input	Crossbar module input 2.
<b>GPIOF7</b>	59	Input	Input/ Output	GPIO Port F7 — After reset, the default state is GPIOF7.
(CMPC_O)			Output	Analog comparator C output.
LP_SDAS1			Output	I <sup>2</sup> C1 secondary serial data line. <b>NOTE:</b> In 4-wire mode, this is the I <sup>2</sup> C slave SDA output for voltage level shift.
(XB_IN3)			Input	Crossbar module input 3.
<b>GPIOF8</b>	6	Input	Input/ Output	GPIO Port F8 — After reset, the default state is GPIOF8.
(RXD0)			Input	SCI0 receive data input.
(XB_OUT10)			Output	Crossbar module output 10.
(CMPD_O)			Output	Analog comparator D output.
(PWMA_2X)			Output	PWM submodule 2, output X or input capture X.

1. The glitch on this pin during ADC sampling may interfere with other analog inputs shared on this pin.

### 3 Signal groups

The input and output signals of this device are organized into functional groups, as detailed in the following table.

**Table 3. Functional Group Pin Allocations**

Functional Group	Number of Pins
	64LQFP
Power Inputs ( $V_{DD}$ , $V_{DDA}$ ), Power output( $V_{CAP}$ )	6
Ground ( $V_{SS}$ , $V_{SSA}$ )	4
Reset	1
eFlexPWM outputs high resolution PWM	8
eFlexPWM outputs without high resolution PWM	6
Queued Serial Peripheral Interface (QSPI0) ports	5
Queued Serial Communications Interface (QSCI0 and QSCI1 ) ports	10
Inter-Integrated Circuit Interface (LPI <sup>2</sup> C0 and LPI <sup>2</sup> C1 ) ports	10
12-bit Analog-to-Digital Converter (ADC) inputs	16
Analog Comparator inputs/outputs	17/6
Analog Operational Amplifier inputs/outputs	8/2
12-bit Digital-to-Analog output	1
Quad Timer Module (TMR) ports	4
Inter-Module Crossbar inputs/outputs	17/19
Clock inputs/outputs	2/2
JTAG / Enhanced On-Chip Emulation (EOnCE)	4

## 4 Pinout

### 4.1 Signal Multiplexing and Pin Assignments

The following table shows the signals available on each pin and the locations of these pins on the devices supported by this document. The Port Control Module is responsible for selecting which ALT functionality is available on each pin.

64 LQFP	Pin Name	Default	ALT0	ALT1	ALT2	ALT3
1	TCK	TCK	GPIOD2			

## Pinout

64 LQFP	Pin Name	Default	ALT0	ALT1	ALT2	ALT3
2	RESET_B	RESET_B	GPIOD4			
3	GPIOC0	GPIOC0	EXTAL	CLKIN0		
4	GPIOC1	GPIOC1	XTAL			
5	GPIOC2	GPIOC2	TXD0	XB_OUT11	XB_IN2	CLK00
6	GPIOF8	GPIOF8	RXD0	XB_OUT10	CMPD_O	PWMA_2X
7	GPIOC3	GPIOC3	TA0	CMPA_O	RXD0	CLKIN1
8	GPIOC4	GPIOC4	TA1	CMPB_O	XB_IN8	OPAMPA_OUT
9	GPIOA7	GPIOA7	ANA7+CMPD_IN3			
10	GPIOA6	GPIOA6	ANA6+CMPD_IN2			
11	GPIOA5	GPIOA5	ANA5+CMPD_IN1			
12	GPIOA4	GPIOA4	ANA4+CMPD_IN0			
13	GPIOA0	GPIOA0	ANA0+CMPA_IN3+OPAMPA_IN3	CMPC_O		
14	GPIOA1	GPIOA1	ANA1+CMPA_IN0+OPAMPA_IN0			
15	GPIOA2	GPIOA2	ANA2+VREFHA+CMPA_IN1+OPAMPA_IN1			
16	GPIOA3	GPIOA3	ANA3+VREFLA+CMPA_IN2+OPAMPA_IN2			
17	GPIOB7	GPIOB7	ANB7+CMPB_IN2+OPAMPB_IN2			
18	GPIOC5	GPIOC5	DACA_O	XB_IN7		
19	GPIOB6	GPIOB6	ANB6+CMPB_IN1+OPAMPB_IN1			
20	GPIOB5	GPIOB5	ANB5+CMPC_IN2			
21	GPIOB4	GPIOB4	ANB4+CMPC_IN1			
22	VDDA	VDDA				
23	VSSA	VSSA				
24	GPIOB0	GPIOB0	ANB0+CMPB_IN3+OPAMPB_IN3			
25	GPIOB1	GPIOB1	ANB1+CMPB_IN0+OPAMPB_IN0			
26	VCAP	VCAP				
27	GPIOB2	GPIOB2	ANB2+VREFHB+CMPC_IN3			
28	GPIOB3	GPIOB3	ANB3+VREFLB+CMPC_IN0			
29	VDD	VDD				
30	VSS	VSS				
31	GPIOC6	GPIOC6	TA2	XB_IN3	CMP_REF	SS0_B
32	GPIOC7	GPIOC7	SS0_B	TXD0	XB_IN8	XB_OUT6
33	GPIOC8	GPIOC8	MISO0	RXD0	XB_IN9	
34	GPIOC9	GPIOC9	SCLK0	XB_IN4	TXD0	XB_OUT8

64 LQFP	Pin Name	Default	ALT0	ALT1	ALT2	ALT3
35	GPIOC10	GPIOC10	MOSIO	XB_IN5	MISO0	XB_OUT9
36	GPIOF0	GPIOF0	XB_IN6			OPAMPB_OUT
37	GPIOC11	GPIOC11	LP_SCLS0	LP_SCL1	TXD1	PWMA_0X
38	GPIOC12	GPIOC12	LP_SDAS0	LP_SDA1	RXD1	PWMA_1X
39	GPIOF2	GPIOF2	LP_SCL1	XB_OUT6	LP_SDA0	
40	GPIOF3	GPIOF3	LP_SDA1	XB_OUT7	LP_SCL0	
41	GPIOF4	GPIOF4	TXD1	XB_OUT8	PWMA_0X	PWMA_FAULT6
42	GPIOF5	GPIOF5	RXD1	XB_OUT9	PWMA_1X	PWMA_FAULT7
43	VSS	VSS				
44	VDD	VDD				
45	GPIOE0	GPIOE0	PWMA_0B			XB_OUT4
46	GPIOE1	GPIOE1	PWMA_0A			XB_OUT5
47	GPIOE2	GPIOE2	PWMA_1B			XB_OUT6
48	GPIOE3	GPIOE3	PWMA_1A			XB_OUT7
49	GPIOC13	GPIOC13	TA3	XB_IN6	EWM_OUT_B	
50	GPIOF1	GPIOF1	CLKO1	XB_IN7	CMPD_O	
51	GPIOE4	GPIOE4	PWMA_2B	XB_IN2	LP_SCL1	XB_OUT8
52	GPIOE5	GPIOE5	PWMA_2A	XB_IN3	LP_SDA1	XB_OUT9
53	GPIOE6	GPIOE6	PWMA_3B	XB_IN4		XB_OUT10
54	GPIOE7	GPIOE7	PWMA_3A	XB_IN5		XB_OUT11
55	GPIOC14	GPIOC14	LP_SDA0	XB_OUT4	PWMA_FAULT4	
56	GPIOC15	GPIOC15	LP_SCL0	XB_OUT5	PWMA_FAULT5	
57	VCAP	VCAP				
58	GPIOF6	GPIOF6		PWMA_3X	LP_SCLS1	XB_IN2
59	GPIOF7	GPIOF7		CMPC_O	LP_SDAS1	XB_IN3
60	VDD	VDD				
61	VSS	VSS				
62	TDO	TDO	GPIOD1			
63	TMS	TMS	GPIOD3			
64	TDI	TDI	GPIOD0			

## 4.2 Pinout diagrams

The following diagrams show pinouts for the packages. For each pin, the diagrams show the default function. However, many signals may be multiplexed onto a single pin.

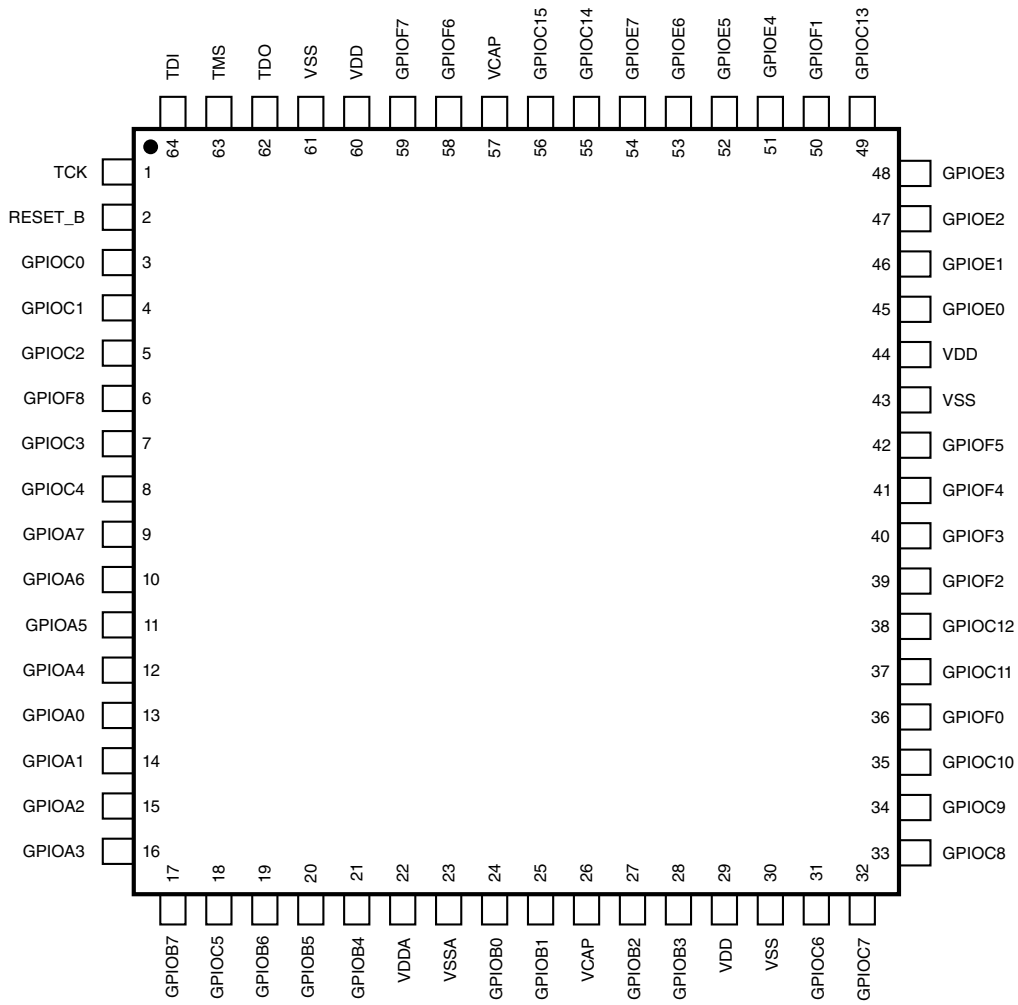

Figure 5. 64-pin LQFP

## 5 Terminology and guidelines



## 5.1 Definition: Operating requirement

An *operating requirement* is a specified value or range of values for a technical characteristic that you must guarantee during operation to avoid incorrect operation and possibly decreasing the useful life of the chip.

### 5.1.1 Example

This is an example of an operating requirement:

Symbol	Description	Min.	Max.	Unit
V <sub>DD</sub>	1.0 V core supply voltage	0.9	1.1	V

## 5.2 Definition: Operating behavior

Unless otherwise specified, an *operating behavior* is a specified value or range of values for a technical characteristic that are guaranteed during operation if you meet the operating requirements and any other specified conditions.

### 5.2.1 Example

This is an example of an operating behavior:

Symbol	Description	Min.	Max.	Unit
I <sub>WP</sub>	Digital I/O weak pullup/pulldown current	10	130	μA

## 5.3 Definition: Attribute

An *attribute* is a specified value or range of values for a technical characteristic that are guaranteed, regardless of whether you meet the operating requirements.

### 5.3.1 Example

This is an example of an attribute:

Symbol	Description	Min.	Max.	Unit
CIN_D	Input capacitance: digital pins	—	7	pF

### 5.4 Definition: Rating

A *rating* is a minimum or maximum value of a technical characteristic that, if exceeded, may cause permanent chip failure:

- *Operating ratings* apply during operation of the chip.
- *Handling ratings* apply when the chip is not powered.

#### 5.4.1 Example

This is an example of an operating rating:

Symbol	Description	Min.	Max.	Unit
V <sub>DD</sub>	1.0 V core supply voltage	-0.3	1.2	V

### 5.5 Result of exceeding a rating

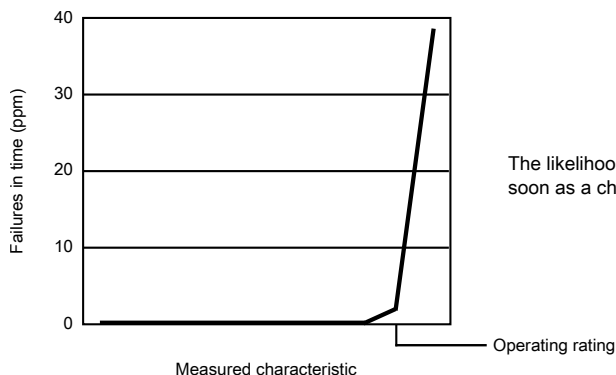

The likelihood of permanent chip failure increases rapidly as soon as a characteristic begins to exceed one of its operating ratings.

## 5.6 Relationship between ratings and operating requirements

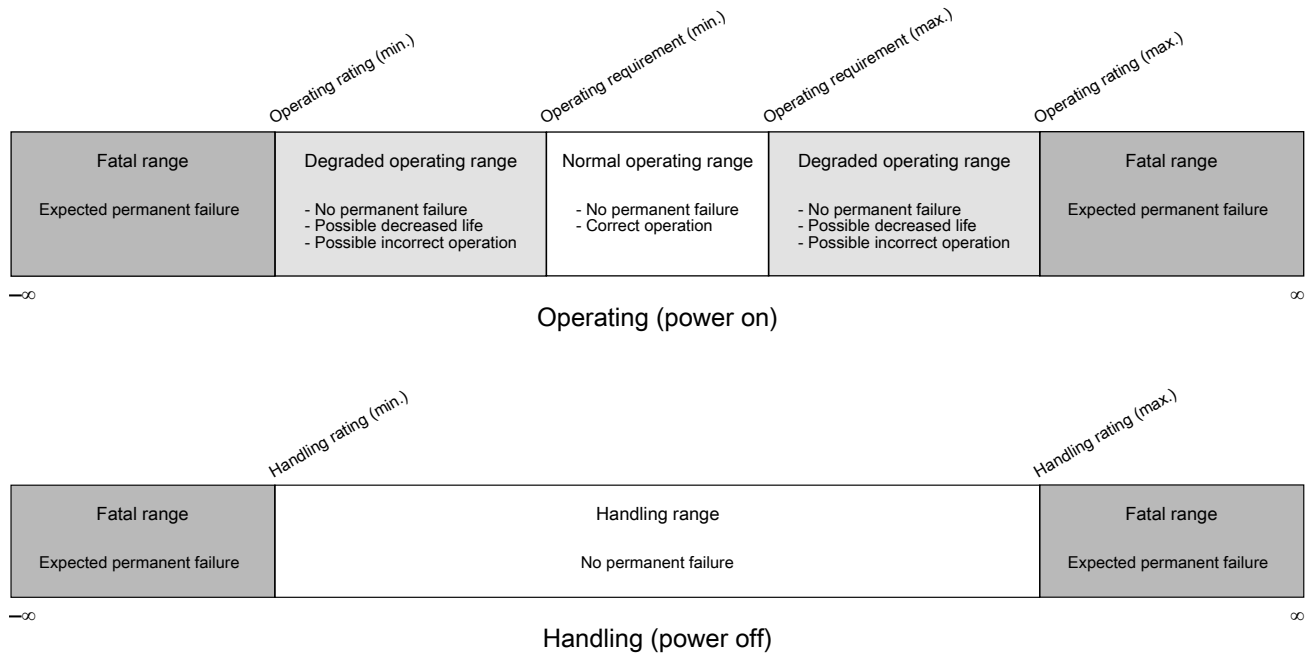

## 5.7 Guidelines for ratings and operating requirements

Follow these guidelines for ratings and operating requirements:

- Never exceed any of the chip's ratings.
- During normal operation, don't exceed any of the chip's operating requirements.
- If you must exceed an operating requirement at times other than during normal operation (for example, during power sequencing), limit the duration as much as possible.

## 5.8 Definition: Typical value

A *typical value* is a specified value for a technical characteristic that:

- Lies within the range of values specified by the operating behavior
- Given the typical manufacturing process, is representative of that characteristic during operation when you meet the typical-value conditions or other specified conditions

Typical values are provided as design guidelines and are neither tested nor guaranteed.

### 5.8.1 Example 1

This is an example of an operating behavior that includes a typical value:

Symbol	Description	Min.	Typ.	Max.	Unit
$I_{WP}$	Digital I/O weak pullup/pulldown current	10	70	130	$\mu A$

### 5.8.2 Example 2

This is an example of a chart that shows typical values for various voltage and temperature conditions:

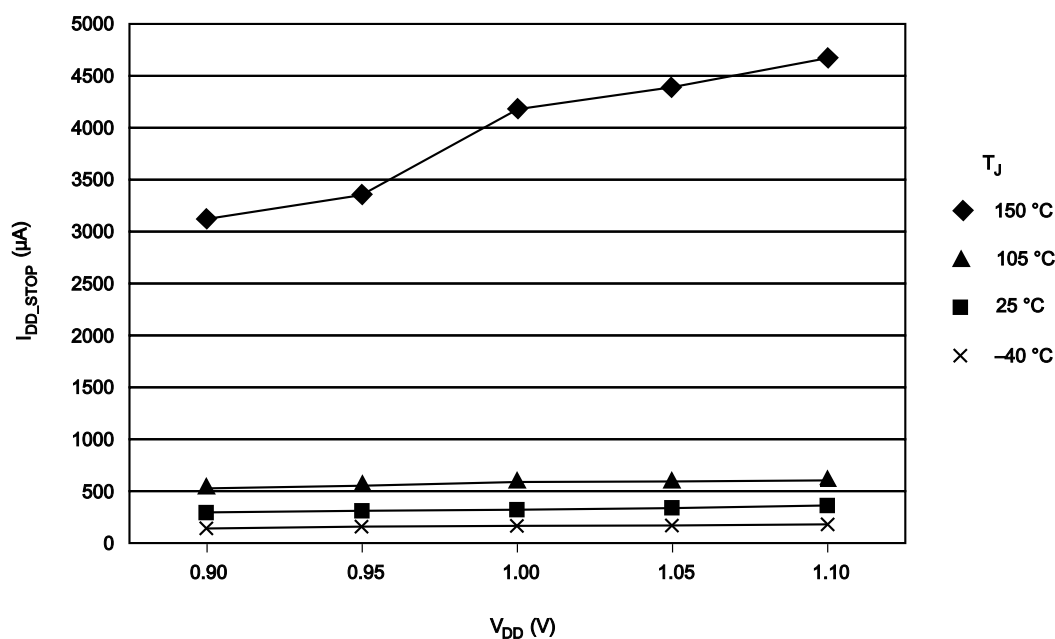

## 5.9 Typical value conditions

Typical values assume you meet the following conditions (or other conditions as specified):

Symbol	Description	Value	Unit
T <sub>A</sub>	Ambient temperature	25	°C
V <sub>DD</sub>	3.3 V supply voltage	3.3	V

## 6 Ratings

### 6.1 Thermal handling ratings

Symbol	Description	Min.	Max.	Unit	Notes
T <sub>STG</sub>	Storage temperature	-55	150	°C	1
T <sub>SDR</sub>	Solder temperature, lead-free	—	260	°C	2

1. Determined according to JEDEC Standard JESD22-A103, *High Temperature Storage Life*.
2. Determined according to IPC/JEDEC Standard J-STD-020, *Moisture/Reflow Sensitivity Classification for Nonhermetic Solid State Surface Mount Devices*.

### 6.2 Moisture handling ratings

Symbol	Description	Min.	Max.	Unit	Notes
MSL	Moisture sensitivity level	—	3	—	1

1. Determined according to IPC/JEDEC Standard J-STD-020, *Moisture/Reflow Sensitivity Classification for Nonhermetic Solid State Surface Mount Devices*.

### 6.3 ESD and latch-up ratings

Although damage from electrostatic discharge (ESD) is much less common on these devices than on early CMOS circuits, use normal handling precautions to avoid exposure to static discharge. Qualification tests are performed to ensure that these devices can withstand exposure to reasonable levels of static without suffering any permanent damage.

A device is defined as a failure if after exposure to ESD pulses, the device no longer meets the device specification. Complete DC parametric and functional testing is performed as per the applicable device specification at room temperature followed by hot temperature, unless specified otherwise in the device specification.

**Table 4. ESD and latch-up ratings**

Characteristic Description <sup>1</sup>	Rating	Notes
Electrostatic discharge voltage, human body model	±2000 V	2
Electrostatic discharge voltage, charged device model	±500 V	3
Latch-up immunity level (Class II at 125 °C junction temperature)	Immunity Level A	4

1. Parameter is achieved by design characterization on a small sample size from typical devices under typical conditions unless otherwise noted.
2. Determined according to ANSI/ESDA/JEDEC Standard JS-001-2017, *For Electrostatic Discharge Sensitivity Testing, Human Body Model (HBM) - Component Level*.
3. Determined according to ANSI/ESDA/JEDEC Standard JS-002-2018, *For Electrostatic Discharge Sensitivity Testing, Charged Device Model (CDM) - Device Level*.
4. Determined according to JEDEC Standard JESD78F, *IC Latch-Up Test*.

## 6.4 Voltage and current operating ratings

**Table 5. Voltage and current operating ratings**

Symbol	Description	Min.	Max.	Unit
$V_{DD}$	Digital supply voltage	-0.3	3.8	V
$I_{DD}$	Digital supply current	—	120	mA
$V_{IO}$	IO pin input voltage	-0.3	$V_{DD} + 0.3$	V
$I_D$	Instantaneous maximum current single pin limit (applies to all port pins)	-25	25	mA
$V_{DDA}$	Analog supply voltage	$V_{DD} - 0.3$	$V_{DD} + 0.3$	V

## 7 General

### 7.1 General characteristics

Absolute maximum ratings in the table of "Voltage and current operating ratings" section are stress ratings only, and functional operation at the maximum is not guaranteed. Stress beyond these ratings may affect device reliability or cause permanent damage to the device.

Unless otherwise stated, all specifications within this chapter apply to the temperature range specified in the table of "Voltage and current operating ratings" section over the following supply ranges:  $V_{SS} = V_{SSA} = 0$  V,  $V_{DD} = V_{DDA} = 3.0$  V to 3.6 V,  $CL \leq 50$  pF,  $f_{OP} = 50$  MHz.

## CAUTION

This device contains protective circuitry to guard against damage due to high static voltage or electrical fields. However, normal precautions are advised to avoid application of any voltages higher than maximum-rated voltages to this high-impedance circuit. Reliability of operation is enhanced if unused inputs are tied to an appropriate voltage level.

## 7.2 AC electrical characteristics

Tests are conducted using the input levels specified in the section "Voltage and current operating behaviors". Unless otherwise specified, propagation delays are measured from the 50% to the 50% point, and rise and fall times are measured between the 20% and 80% points, as shown in [Figure 6](#).

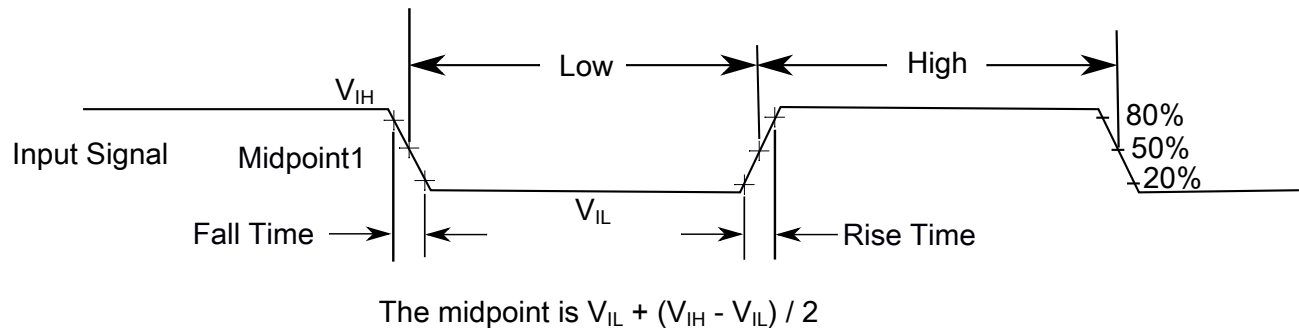

**Figure 6. Input signal measurement references**

All digital I/O switching characteristics, unless otherwise specified, assume that the output pins have the following characteristics.

- $C_L=30$  pF loads
- Slew rate disabled
- Normal drive strength

[Figure 7](#) shows the definitions of the following signal states:

- Active state, when a bus or signal is driven, and enters a low impedance state
- Tri-stated, when a bus or signal is placed in a high impedance state
- Data Valid state, when a signal level has reached  $V_{OL}$  or  $V_{OH}$
- Data Invalid state, when a signal level is in transition between  $V_{OL}$  and  $V_{OH}$

## General

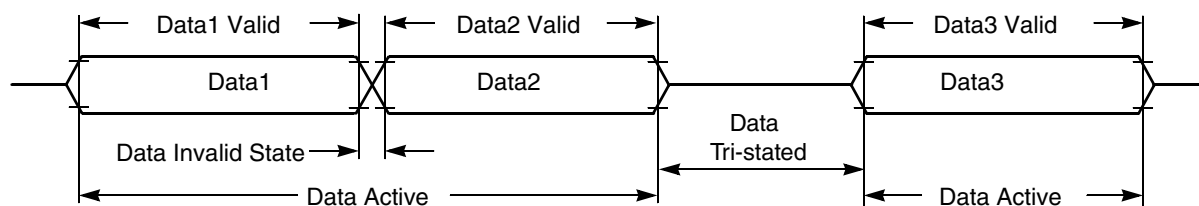

**Figure 7. Signal states**

## 7.3 Nonswitching electrical specifications

### 7.3.1 Voltage and current operating requirements

This section includes information about recommended operating conditions.

**Table 6. Voltage and current operating requirements**

Symbol	Description	Min.	Typ.	Max.	Unit	Notes
$V_{DD}$	Supply voltage	2.7	3.3	3.6	V	—
$V_{DDA}$	Analog supply voltage	2.7	3.3	3.6	V	—
$V_{DD} - V_{DDA}$	$V_{DD}$ -to- $V_{DDA}$ differential voltage	-0.1		0.1	V	—
$V_{SS} - V_{SSA}$	$V_{SS}$ -to- $V_{SSA}$ differential voltage	-0.1		0.1	V	—
$V_{IH}$	Input high voltage • $2.7\text{ V} \leq V_{DD} \leq 3.6\text{ V}$	$0.7 \times V_{DD}$		—	V	—
$V_{IL}$	Input low voltage • $2.7\text{ V} \leq V_{DD} \leq 3.6\text{ V}$	—		$0.35 \times V_{DD}$	V	—
$V_{HYS}$	Input hysteresis	$0.06 \times V_{DD}$		—	V	—
$V_{IHOSC}$	Oscillator Input Voltage High XTAL driven by an external clock source	2.0		$V_{DD} + 0.3$	V	—
$V_{ILOSC}$	Oscillator Input Voltage Low	-0.3		0.8	V	—
$I_{ICIO}$	IO pin negative DC injection current—single pin • $V_{IN} < V_{SS} - 0.3\text{V}$	-3		—	mA	1
$I_{ICcont}$	Contiguous pin DC injection current —regional limit, includes sum of negative injection currents of 16 contiguous pins • Negative current injection	-25		—	mA	—

- All I/O pins are internally clamped to  $V_{SS}$  through a ESD protection diode. There is no diode connection to  $V_{DD}$ . If  $V_{IN}$  greater than  $V_{IO\_MIN}$  ( $= V_{SS} - 0.3\text{ V}$ ) is observed, then there is no need to provide current limiting resistors at the pads. If this limit cannot be observed then a current limiting resistor is required. The negative DC injection current limiting resistor is calculated as  $R = (V_{IO\_MIN} - V_{IN}) / |I_{ICIO}|$ .



## 7.3.2 LVD and POR operating requirements

**Table 7. PMC Low-Voltage Detection (LVD) and Power-On Reset (POR) Parameters**

Characteristic	Symbol	Min	Typ	Max	Unit
POR Assert Voltage <sup>1</sup>	POR		2.0		V
POR Release Voltage <sup>2</sup>	POR		2.7		V
Low-Voltage Warning Interrupt	LVI_2p7		2.73		V
Low-Voltage Alarm Interrupt	LVI_2p2		2.23		V

1. During 3.3-volt  $V_{DD}$  power supply ramp down
2. During 3.3-volt  $V_{DD}$  power supply ramp up (gated by LVI\_2p7)

## 7.3.3 Voltage and current operating behaviors

**Table 8. Voltage and current operating behaviors**

Symbol	Description	Min.	Max.	Unit	Notes
$V_{OH}$	Output high voltage — Normal drive pad (except RESET) • $2.7\text{ V} \leq V_{DD} \leq 3.6\text{ V}$ , $I_{OH} = -5\text{ mA}$	$V_{DD} - 0.5$	—	V	1
$V_{OH}$	Output high voltage — High drive pad (except RESET) • $2.7\text{ V} \leq V_{DD} \leq 3.6\text{ V}$ , $I_{OH} = -20\text{ mA}$	$V_{DD} - 0.5$	—	V	2, 1
$I_{OHT}$	Output high current total for all ports	—	100	mA	—
$V_{OL}$	Output low voltage — Normal drive pad (except RESET) • $2.7\text{ V} \leq V_{DD} \leq 3.6\text{ V}$ , $I_{OL} = 5\text{ mA}$	—	0.5	V	1
$V_{OL}$	Output low voltage — High drive pad (except RESET) • $2.7\text{ V} \leq V_{DD} \leq 3.6\text{ V}$ , $I_{OL} = 20\text{ mA}$	—	0.5	V	2, 1
$I_{OLT}$	Output low current total for all ports	—	100	mA	—
$I_{IN}$	Input leakage current (per pin) for full temperature range	—	1	$\mu\text{A}$	3
$I_{IN}$	Input leakage current (per pin) at 25 °C	—	0.025	$\mu\text{A}$	3
$I_{IN}$	Input leakage current (total all pins) for full temperature range	—	41	$\mu\text{A}$	3
$I_{OZ}$	Hi-Z (off-state) leakage current (per pin)	—	1	$\mu\text{A}$	—
$R_{PU}$	Internal pullup resistors	20	50	$\text{k}\Omega$	4
$R_{PD}$	Internal pulldown resistors	20	50	$\text{k}\Omega$	5

## General

1. The reset pin only contains an active pull down device when configured as the RESET signal or as a GPIO. When configured as a GPIO output, it acts as a pseudo open drain output.
2. GPIOC2, GPIOC7~12, GPIOF2~3 and GPIOC14~15 support high drive strength mode.
3. Measured at  $V_{DD} = 3.6\text{ V}$
4. Measured at  $V_{DD}$  supply voltage =  $V_{DD}$  min and  $V_{input} = V_{SS}$
5. Measured at  $V_{DD}$  supply voltage =  $V_{DD}$  min and  $V_{input} = V_{DD}$

## 7.3.4 Power mode transition operating behaviors

Parameters listed are guaranteed by design.

### NOTE

All address and data buses described here are internal.

**Table 9. Reset, stop, wait, and interrupt timing**

Characteristic	Symbol	Typical Min	Typical Max	Unit	See Figure
Minimum $\overline{\text{RESET}}$ Assertion Duration	$t_{RA}$	16 <sup>1</sup>	—	ns	—
$\overline{\text{RESET}}$ deassertion to First Address Fetch	$t_{RDA}$	$865 \times T_{OSC} + 8 \times T$	—	ns	—
Delay from Interrupt Assertion to Fetch of first instruction (exiting Stop)	$t_{IF}$	361.3	570.9	ns	—

1. If the  $\overline{\text{RESET}}$  pin filter is enabled by setting the RST\_FLT bit in the SIM\_CTRL register to 1, the minimum pulse assertion must be greater than 21 ns. Recommended a capacitor of up to 0.1  $\mu\text{F}$  on  $\overline{\text{RESET}}$ .

### NOTE

In [Table 9](#),  $T$  = system clock cycle and  $T_{OSC}$  = oscillator clock cycle. For an operating frequency of 50MHz,  $T=20\text{ ns}$ . At 4 MHz (used coming out of reset and stop modes),  $T=250\text{ ns}$ .

**Table 10. Power mode transition behavior**

Symbol	Description	Typical	Max	Unit	Notes <sup>1</sup>
$T_{POR}$	After a POR event, the amount of delay from when $V_{DD}$ reaches 2.7 V to when the first instruction executes (over the operating temperature range).	250	288	$\mu\text{s}$	
	STOP mode to RUN mode	7.10	8.17	$\mu\text{s}$	<a href="#">2</a>
	LPS mode to LPRUN mode	285	328	$\mu\text{s}$	<a href="#">3</a>
	VLPS mode to VLPRUN mode	878	1010	$\mu\text{s}$	<a href="#">4</a>
	WAIT mode to RUN mode	0.395	0.454	$\mu\text{s}$	<a href="#">5</a>
	LPWAIT mode to LPRUN mode	285	328	$\mu\text{s}$	<a href="#">3</a>
	VLPWAIT mode to VLPRUN mode	868	998	$\mu\text{s}$	<a href="#">4</a>

1. Wakeup times are measured from GPIO toggle for wakeup till GPIO toggle at the wakeup interrupt subroutine from respective stop/wait mode.
2. Clock configuration: CPU clock=4 MHz. System clock source is 8 MHz IRC in normal mode.

3. CPU clock = 200 kHz and 8 MHz IRC on standby. Exit by an interrupt on PORTA GPIO.
4. Using 64 kHz external clock; CPU Clock = 32 kHz. Exit by an interrupt on PORTA GPIO.
5. Clock configuration: CPU and system clocks= 100 MHz. Bus Clock = 50MHz. Exit by interrupt on PORTA GPIO

### 7.3.5 Power consumption operating behaviors

Table 11. Current Consumption (Unit: mA)

Mode	Maximum Frequency	Conditions <sup>1</sup>	Typical at 3.3 V, 25°C		Maximum at 3.6 V, 105°C	
			I <sub>DD</sub> <sup>1</sup>	I <sub>DDA</sub>	I <sub>DD</sub> <sup>1</sup>	I <sub>DDA</sub>
RUN1	100 MHz	<ul style="list-style-type: none"> <li>• 100 MHz Core</li> <li>• 50 MHz Peripheral clock</li> <li>• Regulators are in full regulation</li> <li>• Relaxation Oscillator on</li> <li>• PLL powered on</li> <li>• Continuous MAC instructions with fetches from Program Flash</li> <li>• All peripheral modules enabled. TMRs and SCIs using 1X peripheral clock</li> <li>• NanoEdge within eFlexPWM using 2X peripheral clock</li> <li>• ADC/DAC (only one 12-bit DAC and all 8-bit DACs) powered on and clocked</li> <li>• Comparator powered on</li> </ul>	33.1	8.6	46.0	14.6
RUN2	50 MHz	<ul style="list-style-type: none"> <li>• 50 MHz Core and Peripheral clock</li> <li>• Regulators are in full regulation</li> <li>• Relaxation Oscillator on</li> <li>• PLL powered on</li> <li>• Continuous MAC instructions with fetches from Program Flash</li> <li>• All peripheral modules enabled. TMRs and SCIs using 1X peripheral clock</li> <li>• NanoEdge within eFlexPWM using 2X peripheral clock</li> <li>• ADC/DAC (only one 12-bit DAC and all 8-bit DACs) powered on and clocked</li> <li>• Comparator powered on</li> </ul>	20.3	8.7	43.0	14.9
WAIT	50 MHz	<ul style="list-style-type: none"> <li>• 50 MHz Core and Peripheral clock</li> <li>• Regulators are in full regulation</li> <li>• Relaxation Oscillator on</li> <li>• PLL powered on</li> <li>• Processor Core in WAIT state</li> <li>• All Peripheral modules enabled.</li> <li>• TMRs and SCIs using 1X Clock</li> <li>• NanoEdge within PWMA using 2X clock</li> <li>• ADC/DAC (single 12-bit DAC, all 8-bit DACs), Comparator powered off</li> </ul>	17.3	—	35.0	—
STOP	4 MHz	<ul style="list-style-type: none"> <li>• 4 MHz Device Clock</li> <li>• Regulators are in full regulation</li> <li>• Relaxation Oscillator on</li> <li>• PLL powered off</li> <li>• Processor Core in STOP state</li> </ul>	4.4	—	15.0	—

Table continues on the next page...

Table 11. Current Consumption (Unit: mA) (continued)

Mode	Maximum Frequency	Conditions <sup>1</sup>	Typical at 3.3 V, 25°C		Maximum at 3.6 V, 105°C	
			I <sub>DD</sub> <sup>1</sup>	I <sub>DDA</sub>	I <sub>DD</sub> <sup>1</sup>	I <sub>DDA</sub>
		<ul style="list-style-type: none"> <li>All peripheral module and core clocks are off</li> <li>ADC/DAC/Comparator powered off</li> </ul>				
LPRUN (LsRUN)	2 MHz	<ul style="list-style-type: none"> <li>200 kHz Device Clock from Relaxation Oscillator's (ROSC) low speed clock</li> <li>ROSC in standby mode</li> <li>Regulators are in standby</li> <li>PLL disabled</li> <li>Repeat NOP instructions</li> <li>All peripheral modules enabled, except NanoEdge and cyclic ADCs. One 12-bit DAC and all 8-bit DACs enabled. <sup>2</sup></li> <li>Simple loop with running from platform instruction buffer</li> </ul>	1.1	2.4	11.1	4.0
LPWAIT (LsWAIT)	2 MHz	<ul style="list-style-type: none"> <li>200 kHz Device Clock from Relaxation Oscillator's (ROSC) low speed clock</li> <li>ROSC in standby mode</li> <li>Regulators are in standby</li> <li>PLL disabled</li> <li>All peripheral modules enabled, except NanoEdge and cyclic ADCs. One 12-bit DAC and all 8-bit DACs enabled. <sup>2</sup></li> <li>Processor core in wait mode</li> </ul>	1.0	2.4	11.1	4.0
LPSTOP (LsSTOP)	2 MHz	<ul style="list-style-type: none"> <li>200 kHz Device Clock from Relaxation Oscillator's (ROSC) low speed clock</li> <li>ROSC in standby mode</li> <li>Regulators are in standby</li> <li>PLL disabled</li> <li>Only PITs and COP enabled; other peripheral modules disabled and clocks gated off <sup>2</sup></li> <li>Processor core in stop mode</li> </ul>	1.0	—	9.1	—
VLPRUN	200 kHz	<ul style="list-style-type: none"> <li>32 kHz Device Clock</li> <li>Clocked by a 64 kHz external clock source</li> <li>Oscillator in power down</li> <li>All ROSCs disabled</li> <li>Large regulator is in standby</li> <li>Small regulator is disabled</li> <li>PLL disabled</li> <li>Repeat NOP instructions</li> <li>All peripheral modules, except COP and EWM, disabled and clocks gated off</li> <li>Simple loop running from platform instruction buffer</li> </ul>	0.4	—	7.5	—
VLPWAIT	200 kHz	<ul style="list-style-type: none"> <li>32 kHz Device Clock</li> <li>Clocked by a 64 kHz external clock source</li> <li>Oscillator in power down</li> <li>All ROSCs disabled</li> <li>Large regulator is in standby</li> <li>Small regulator is disabled</li> <li>PLL disabled</li> </ul>	0.4	—	7.5	—

Table continues on the next page...

**Table 11. Current Consumption (Unit: mA) (continued)**

Mode	Maximum Frequency	Conditions <sup>1</sup>	Typical at 3.3 V, 25°C		Maximum at 3.6 V, 105°C	
			I <sub>DD</sub> <sup>1</sup>	I <sub>DDA</sub>	I <sub>DD</sub> <sup>1</sup>	I <sub>DDA</sub>
		<ul style="list-style-type: none"> <li>All peripheral modules, except COP, disabled and clocks gated off</li> <li>Processor core in wait mode</li> </ul>				
VLPSTOP	200 kHz	<ul style="list-style-type: none"> <li>32 kHz Device Clock</li> <li>Clocked by a 64 kHz external clock source</li> <li>Oscillator in power down</li> <li>All ROSCs disabled</li> <li>Large regulator is in standby.</li> <li>Small regulator is disabled.</li> <li>PLL disabled</li> <li>All peripheral modules, except COP, disabled and clocks gated off</li> <li>Processor core in stop mode</li> </ul>	0.4	—	7.5	—

1. No output switching, all ports configured as inputs, all inputs low, no DC loads.
2. In all chip LP modes and flash memory VLP modes, the maximum frequency for flash memory operation is 500 kHz due to the fixed frequency ratio of 1:2 between the CPU clock and the flash clock when running with 2 MHz external clock input and CPU running at 1 MHz.

### 7.3.6 Designing with radiated emissions in mind

To find application notes that provide guidance on designing your system to minimize interference from radiated emissions:

1. Go to [www.nxp.com](http://www.nxp.com).
2. Perform a keyword search for “EMC design.”

### 7.3.7 Capacitance attributes

**Table 12. Capacitance attributes**

Description	Symbol	Min.	Typ.	Max.	Unit
Input capacitance	C <sub>IN</sub>	—	10	—	pF
Output capacitance	C <sub>OUT</sub>	—	10	—	pF

## 7.4 Switching specifications

## 7.4.1 Device clock specifications

**Table 13. Device clock specifications**

Symbol	Description	Min.	Max.	Unit	Notes
Normal run mode					
$f_{\text{SYSCLK}}$	Device (system and core) clock frequency <ul style="list-style-type: none"> <li>• using relaxation oscillator</li> <li>• using external clock source</li> </ul>	0.001 0	100 100	MHz	
$f_{\text{BUS}}$	Bus clock	—	50	MHz	

## 7.4.2 General switching specifications

These general-purpose specifications apply to all signals configured for GPIO signals.

**Table 14. General switching specifications**

Description	Min.	Max.	Unit	Notes
GPIO pin interrupt pulse width (digital glitch filter disabled) — Synchronous path	1.5	—	Bus clock cycles	1
External RESET and NMI pin interrupt pulse width — Asynchronous path	100	—	ns	2
GPIO pin interrupt pulse width — Asynchronous path	16	—	ns	2
Port rise and fall time	—	36	ns	3

1. The synchronous and asynchronous timing must be met.
2. This is the shortest pulse that is guaranteed to be recognized.
3. 75 pF load

## 7.5 Thermal specifications

### 7.5.1 Thermal operating requirements

**Table 15. Thermal operating requirements**

Symbol	Description	Grade	Min	Max	Unit
$T_J$	Die junction temperature	V	−40	125	°C
$T_A$	Ambient temperature	V	−40	105	°C

## 7.5.2 Thermal attributes

This section provides information about operating temperature range, power dissipation, and package thermal resistance. Power dissipation on I/O pins is usually small compared to the power dissipation in on-chip logic and voltage regulator circuits, and it is user-determined rather than being controlled by the MCU design. To account for  $P_{I/O}$  in power calculations, determine the difference between actual pin voltage and  $V_{SS}$  or  $V_{DD}$  and multiply by the pin current for each I/O pin. Except in cases of unusually high pin current (heavy loads), the difference between pin voltage and  $V_{SS}$  or  $V_{DD}$  is very small.

See [Thermal design considerations](#) for more detail on thermal design considerations.

Board type <sup>1</sup>	Symbol	Description	64 LQFP	Unit	Notes
Four-layer (2s2p)	$R_{\theta JA}$	Thermal resistance, junction to ambient (natural convection)	52	°C/W	2
Single-layer (1s)	$R_{\theta JC}$	Thermal resistance, junction to case	20	°C/W	3
—	$\Psi_{JT}$	Thermal characterization parameter, junction to package top outside center (natural convection)	3	°C/W	2

1. Thermal test board meets JEDEC specification for this package (JESD51-7, 2s2p and JESD51-3, 1s).
2. Determined in accordance to JEDEC JESD51-2A natural convection environment. Thermal resistance data in this report is solely for a thermal performance comparison of one package to another in a standardized specified environment. It is not meant to predict the performance of a package in an application-specific environment.
3. Junction-to-Case (Top) thermal resistance is determined using an isothermal cold plate attached to the package top. Case (Top) temperature refers to the mold surface temperature at the center.

## 8 Peripheral operating requirements and behaviors

### 8.1 Core modules

### 8.1.1 JTAG timing

Table 16. JTAG timing

Characteristic	Symbol	Min	Max	Unit	See Figure
TCK frequency of operation	$f_{OP}$	DC	SYS_CLK/ 8	MHz	Figure 8
TCK clock pulse width	$t_{PW}$	50	—	ns	Figure 8
TMS, TDI data set-up time	$t_{DS}$	5	—	ns	Figure 9
TMS, TDI data hold time	$t_{DH}$	5	—	ns	Figure 9
TCK low to TDO data valid	$t_{DV}$	—	30	ns	Figure 9
TCK low to TDO tri-state	$t_{TS}$	—	30	ns	Figure 9

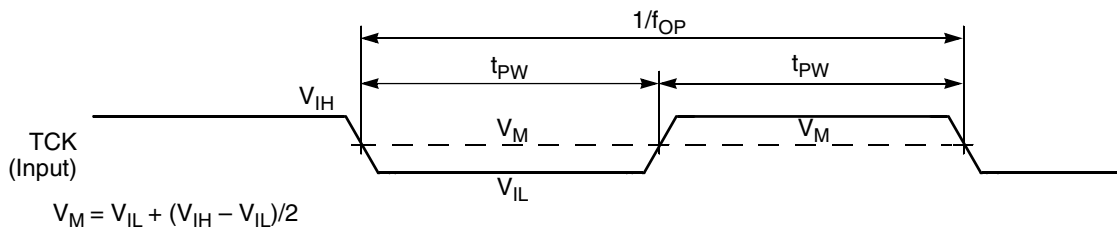

Figure 8. Test clock input timing diagram

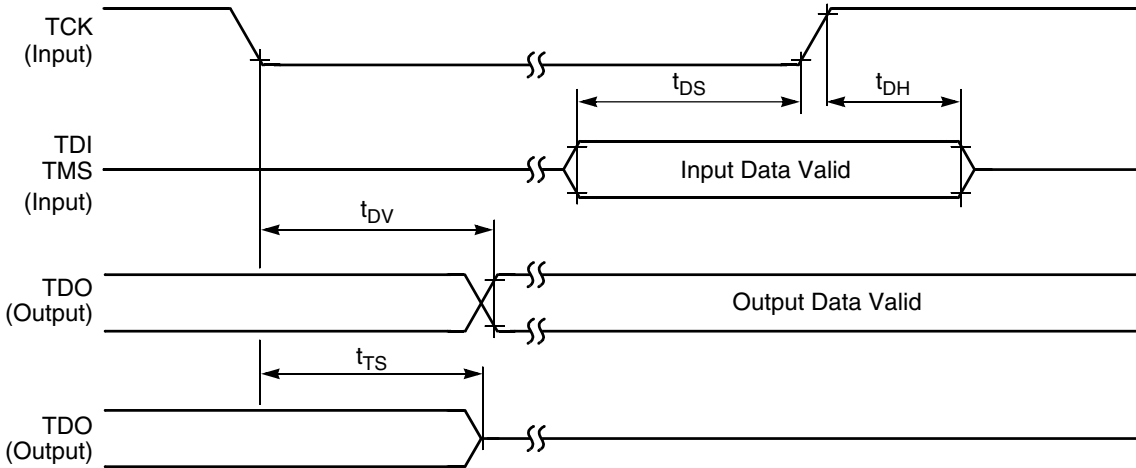

Figure 9. Test access port timing diagram



## 8.2 System modules

### 8.2.1 Voltage regulator specifications

The voltage regulator supplies approximately 1.2 V to the device's core logic. For proper operations, the voltage regulator requires a minimum external 2.2  $\mu\text{F}$  capacitor on each  $V_{\text{CAP}}$  pin with total capacitors on all  $V_{\text{CAP}}$  pins at a minimum of 4.4  $\mu\text{F}$ . Ceramic and tantalum capacitors tend to provide better performance tolerances. The output voltage can be measured directly on the  $V_{\text{CAP}}$  pin. The specifications for this regulator are shown in [Table 17](#).

**Table 17. Regulator 1.2 V parameters**

Characteristic	Symbol	Min	Typ	Max	Unit
Output Voltage <sup>1</sup>	$V_{\text{CAP}}$	—	1.23	—	V
Short Circuit Current <sup>2</sup>	$I_{\text{SS}}$	—	600	—	mA
Short Circuit Tolerance ( $V_{\text{CAP}}$ shorted to ground)	$T_{\text{RSC}}$	—	—	1	minute

1. Value is after trim
2. Guaranteed by design

**Table 18. Bandgap electrical specifications**

Characteristic	Symbol	Min	Typ	Max	Unit
Reference Voltage (after trim)	$V_{\text{REF}}$	—	1.24 <sup>1</sup>	—	V

1. Typical value is trimmed at 25°C. There could be  $\pm 50$  mV variation due to temperature change.

## 8.3 Clock modules

### 8.3.1 External clock operation timing

Parameters listed are guaranteed by design.

**Table 19. External clock operation timing requirements**

Characteristic	Symbol	Min	Typ	Max	Unit
Frequency of operation (external clock driver) <sup>1</sup>	$f_{\text{osc}}$	—	—	50	MHz
Clock pulse width <sup>2</sup>	$t_{\text{PW}}$	8			ns

*Table continues on the next page...*

**Table 19. External clock operation timing requirements (continued)**

Characteristic	Symbol	Min	Typ	Max	Unit
External clock input rise time <sup>3</sup>	$t_{rise}$	—	1.9	2.5	ns
External clock input fall time <sup>4</sup>	$t_{fall}$	—	1.9	2.5	ns
Input high voltage overdrive by an external clock	$V_{ih}$	$0.85 \times V_{DD}$	—	—	V
Input low voltage overdrive by an external clock	$V_{il}$	—	—	$0.3 \times V_{DD}$	V

1. See the "External clock timing" figure for details on using the recommended connection of an external clock driver.
2. The chip may not function if the high or low pulse width is smaller than 6.25 ns.
3. External clock input rise time is measured from 10% to 90%.
4. External clock input fall time is measured from 90% to 10%.

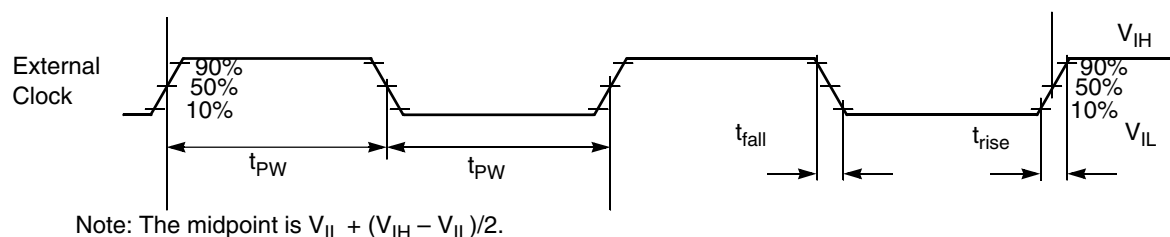

**Figure 10. External clock timing**

### 8.3.2 Phase-Locked Loop timing

**Table 20. Phase-Locked Loop timing**

Characteristic	Symbol	Min	Typ	Max	Unit
PLL input reference frequency <sup>1</sup>	$f_{ref}$	8	8	16	MHz
PLL output frequency <sup>2</sup>	$f_{op}$	200	—	550	MHz
PLL lock time <sup>3</sup>	$t_{pils}$	—	—	100	$\mu s$
Allowed Duty Cycle of input reference	$t_{dc}$	40	50	60	%

1. An externally supplied reference clock should be as free as possible from any phase jitter for the PLL to work correctly. The PLL is designed for 8 MHz ~ 16 MHz input, but optimized for 8 MHz input.
2. The frequency of the core system clock cannot exceed 100 MHz. If the NanoEdge PWM is available, the PLL output must be set to 400 MHz.
3. This is the time required *after the PLL is enabled* to ensure reliable operation.

### 8.3.3 External crystal or resonator requirement

**Table 21. Crystal or resonator requirement**

Characteristic	Symbol	Min	Typ	Max	Unit
Frequency of operation	$f_{XOSC}$	4	8	16	MHz

## 8.3.4 RC Oscillator Timing

Table 22. RC Oscillator Electrical Specifications

Characteristic		Symbol	Min	Typ	Max	Unit
8 MHz Output Frequency <sup>1</sup>						
Run Mode	0°C to 105°C		7.84	8	8.16	MHz
	-40°C to 105°C		7.76	8	8.24	MHz
2M Mode (IRC trimmed @ 8 MHz)	-40°C to 105°C		1.9	2.0	2.1	MHz
8 MHz Frequency Variation over 25°C						
RUN Mode	0°C to 105°C			±1.5	±2	%
	-40°C to 105°C			±1.5	±3	%
	200 kHz Output Frequency <sup>2</sup>					
RUN Mode	-40°C to 105°C		194	200	206	kHz
	200 kHz Output Frequency Variation over 25°C					
RUN Mode	0°C to 85°C			±1.5	±2	%
	-40°C to 105°C			±1.5	±3	%
Stabilization Time	8 MHz output <sup>3</sup>	tstab	1	-	15	µs
	200 kHz output <sup>3</sup>		-	125	375	µs
Output Duty Cycle			45	50	55	%

1. Frequency after factory trim
2. Frequency after factory trim
3. Power down to run mode transition

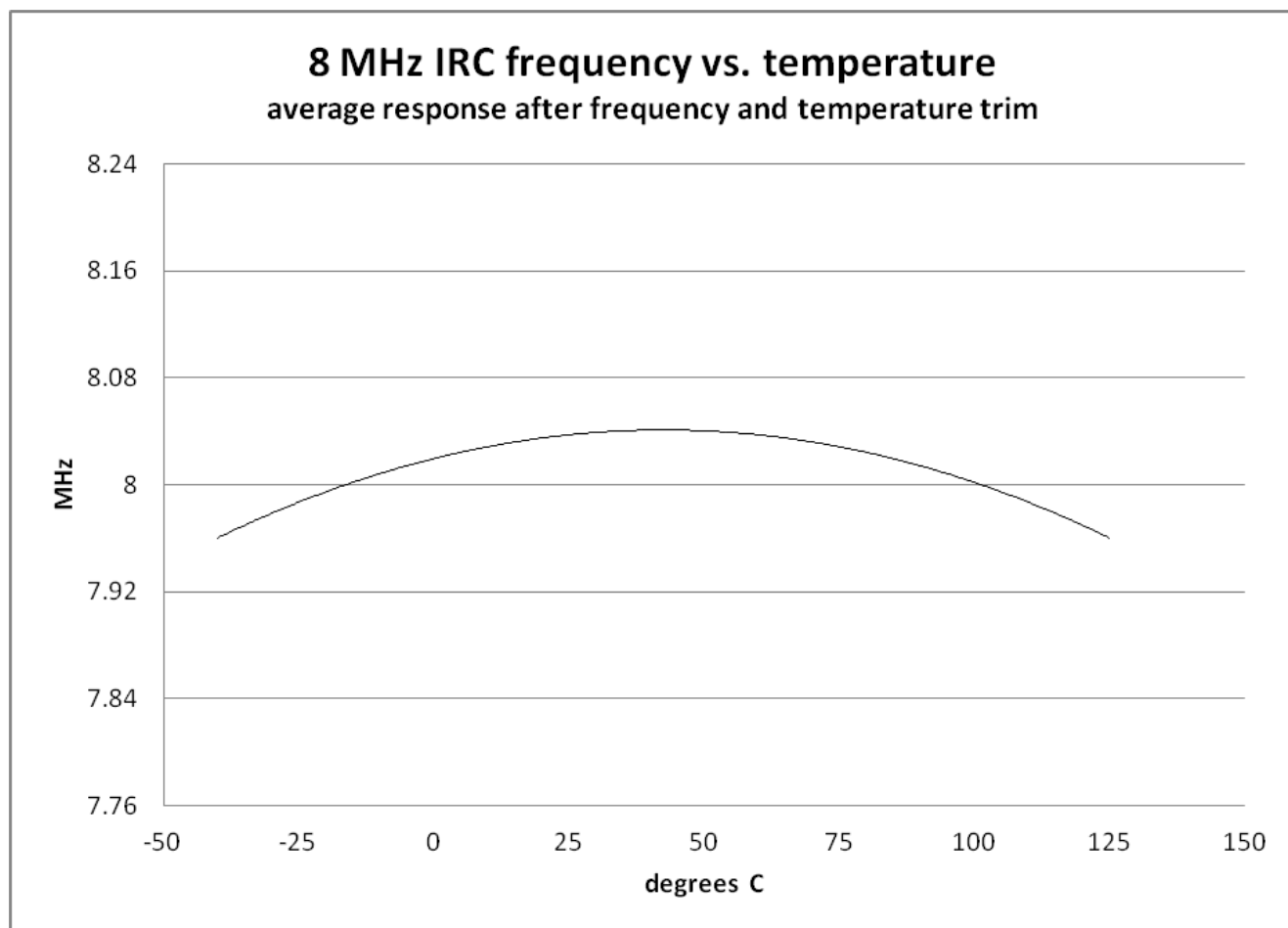

Figure 11. RC Oscillator Temperature Variation (Typical) After Trim (Preliminary)

## 8.4 Memories and memory interfaces

### 8.4.1 Flash electrical specifications

This section describes the electrical characteristics of the flash memory module.

#### 8.4.1.1 Flash timing specifications — program and erase

The following specifications represent the amount of time the internal charge pumps are active and do not include command overhead.

**Table 23. NVM program/erase timing specifications**

Symbol	Description	Min.	Typ.	Max.	Unit	Notes
$t_{hvpgm4}$	Longword Program high-voltage time	—	7.5	18	$\mu$ s	—
$t_{hversscr}$	Sector Erase high-voltage time	—	13	113	ms	1
$t_{hversall}$	Erase All high-voltage time	—	52	452	ms	1

1. Maximum time based on expectations at cycling end-of-life.

### 8.4.1.2 Flash timing specifications — commands

**Table 24. Flash command timing specifications**

Symbol	Description	Min.	Typ.	Max.	Unit	Notes
$t_{rd1sec1k}$	Read 1s Section execution time (flash sector)	—	—	60	$\mu$ s	1
$t_{pgmchk}$	Program Check execution time	—	—	45	$\mu$ s	1
$t_{rdsrc}$	Read Resource execution time	—	—	30	$\mu$ s	1
$t_{pgm4}$	Program Longword execution time	—	65	145	$\mu$ s	—
$t_{ersscr}$	Erase Flash Sector execution time	—	14	114	ms	2
$t_{rd1all}$	Read 1s All Blocks execution time	—	—	1.8	ms	1
$t_{rdonce}$	Read Once execution time	—	—	25	$\mu$ s	1
$t_{pgmonce}$	Program Once execution time	—	65	—	$\mu$ s	—
$t_{ersall}$	Erase All Blocks execution time	—	88	650	ms	2
$t_{vfykey}$	Verify Backdoor Access Key execution time	—	—	30	$\mu$ s	1
$t_{ersallu}$	Erase All Blocks Unsecure execution time	—	88	650	ms	2

1. Assumes 25 MHz flash clock frequency.
2. Maximum times for erase parameters based on expectations at cycling end-of-life.

### 8.4.1.3 Flash high voltage current behaviors

**Table 25. Flash high voltage current behaviors**

Symbol	Description	Min.	Typ.	Max.	Unit
$I_{DD\_PGM}$	Average current adder during high voltage flash programming operation	—	2.5	6.0	mA
$I_{DD\_ERS}$	Average current adder during high voltage flash erase operation	—	1.5	4.0	mA

### 8.4.1.4 Reliability specifications (Industrial)

**Table 26. NVM reliability specifications**

Symbol	Description	Min.	Typ. <sup>1</sup>	Max.	Unit	Notes
Program Flash						

*Table continues on the next page...*

**Table 26. NVM reliability specifications (continued)**

Symbol	Description	Min.	Typ. <sup>1</sup>	Max.	Unit	Notes
$t_{\text{nvmpretp10k}}$	Data retention after up to 10 K cycles	5	50	—	years	—
$t_{\text{nvmpretp1k}}$	Data retention after up to 1 K cycles	20	100	—	years	—
$n_{\text{nvmcycp}}$	Cycling endurance	10 K	50 K	—	cycles	2
$n_{\text{nvmcycp}}$	Cycling endurance	1 K	—	—	cycles	3

1. Typical data retention values are based on measured response accelerated at high temperature and derated to a constant 25 °C use profile. Engineering Bulletin EB618 does not apply to this technology. Typical endurance defined in Engineering Bulletin EB619.
2. Cycling endurance represents number of program/erase cycles at  $-40\text{ °C} \leq T_j \leq 125\text{ °C}$ .
3. Cycling endurance represents number of program/erase cycles at  $-40\text{ °C} \leq T_j \leq 135\text{ °C}$ . If the product application is exposed to  $T_j > 125\text{ °C}$ , the reduced W/E spec applies independent of the number of W/E cycles in the high  $T_j$  band.

### 8.4.1.5 Reliability specifications (Automotive)

**Table 27. NVM reliability specifications**

Symbol	Description	Min.	Typ.	Max.	Unit	Notes
Program Flash						
$t_{\text{nvmpret1k}}$	Data retention after up to 1 K cycles	20	—	—	years	1
$n_{\text{nvmcyc}}$	Cycling endurance	1 K	—	—	cycles	2

1. Data retention period per block begins upon initial user factory programming or after each subsequent erase.
2. Program and Erase are supported across product temperature specification. Cycling endurance is per flash sector.

## 8.5 Analog

### 8.5.1 12-bit Cyclic Analog-to-Digital Converter (ADC) Parameters

**Table 28. 12-bit ADC Electrical Specifications**

Characteristic	Symbol	Min	Typ	Max	Unit
<b>Recommended Operating Conditions</b>					
Supply Voltage <sup>1</sup>	VDDA	3	3.3	3.6	V
VREFH (in external reference mode)	Vrefhx	VDDA-0.6		VDDA	V
ADC Conversion Clock <sup>2</sup>	$f_{\text{ADCCLK}}$	0.1		12.5	MHz
Conversion Range <sup>3</sup>	$R_{\text{AD}}$			$V_{\text{REFH}} - V_{\text{REFL}}$	V
Fully Differential		$-(V_{\text{REFH}} - V_{\text{REFL}})$		$V_{\text{REFH}}$	
Single Ended/Unipolar		$V_{\text{REFL}}$			
Input Voltage Range (per input) <sup>4</sup>	$V_{\text{ADIN}}$	$V_{\text{REFL}}$		$V_{\text{REFH}}$	V

Table continues on the next page...

Table 28. 12-bit ADC Electrical Specifications (continued)

Characteristic	Symbol	Min	Typ	Max	Unit
External Reference		0		$V_{DDA}$	
Internal Reference					
<b>Timing and Power</b>					
Conversion Time <sup>5</sup>	$t_{ADC}$		8		ADC Clock Cycles
ADC Power-Up Time (from adc_pdn)	$t_{ADPU}$		13		ADC Clock Cycles
ADC RUN Current (per ADC block)	$I_{ADRUN}$		2.5		mA
ADC Powerdown Current (adc_pdn enabled)	$I_{ADPWRDWN}$		0.1		$\mu$ A
$V_{REFH}$ Current (in external mode)	$I_{VREFH}$		190	225	$\mu$ A
<b>Accuracy (DC or Absolute)</b>					
Integral non-Linearity <sup>6</sup>	INL		+/- 1.5	+/- 2.2	LSB <sup>7</sup>
Differential non-Linearity <sup>6</sup>	DNL		+/- 0.5	+/- 0.8	LSB <sup>7</sup>
Monotonicity			GUARANTEED		
Offset <sup>8</sup>	$V_{OFFSET}$		+/- 8		mV
Fully Differential			+/- 12		
Single Ended/Unipolar					
Gain Error	$E_{GAIN}$		0.996 to 1.004	0.990 to 1.010	
<b>AC Specifications<sup>9</sup></b>					
Signal to Noise Ratio	SNR		66		dB
Total Harmonic Distortion	THD		75		dB
Spurious Free Dynamic Range	SFDR		77		dB
Signal to Noise plus Distortion	SINAD		66		dB
Effective Number of Bits	ENOB		—		bits
Gain = 1x (Fully Differential/ Unipolar)			10.6		
Gain = 2x (Fully Differential/ Unipolar)			—		
Gain = 4x (Fully Differential/ Unipolar)			10.3		
Gain = 1x (Single Ended)			10.6		
Gain = 2x (Single Ended)			10.4		
Gain = 4x (Single Ended)			10.2		
Variation across channels <sup>10</sup>			0.1		
<b>ADC Inputs</b>					
Input Leakage Current	$I_{IN}$		1		nA
Temperature sensor slope	$T_{SLOPE}$		1.3		mV/ $^{\circ}$ C

Table continues on the next page...

**Table 28. 12-bit ADC Electrical Specifications (continued)**

Characteristic	Symbol	Min	Typ	Max	Unit
Temperature sensor voltage at 25 °C	V <sub>TEMP25</sub>		0.82		V
<b>Disturbance</b>					
Input Injection Current <sup>11</sup>	I <sub>INJ</sub>			+/-3	mA
Channel to Channel Crosstalk <sup>12</sup>	ISOXTLK		-82		dB
Memory Crosstalk <sup>13</sup>	MEMXTLK		-71		dB
Input Capacitance Sampling Capacitor	C <sub>ADI</sub>		4.8		pF

1. The ADC functions up to VDDA = 2.7 V. When VDDA is below 3.0 V, ADC specifications are not guaranteed
2. ADC clock duty cycle is 45% ~ 55%
3. Conversion range is defined for x1 gain setting. For x2 and x4 the range is 1/2 and 1/4, respectively.
4. In unipolar mode, positive input must be ensured to be always greater than negative input.
5. First conversion takes 10 clock cycles.
6. INL/DNL is measured from V<sub>IN</sub> = V<sub>REFL</sub> to V<sub>IN</sub> = V<sub>REFH</sub> using Histogram method at x1 gain setting
7. Least Significant Bit = 0.806 mV at 3.3 V V<sub>DDA</sub>, x1 gain Setting
8. Offset measured at 2048 code
9. Measured converting a 1 kHz input full scale sine wave
10. When code runs from internal RAM
11. The current that can be injected into or sourced from an unselected ADC input without affecting the performance of the ADC
12. Any off-channel with 50 kHz full-scale input to the channel being sampled with DC input (isolation crosstalk)
13. From a previously sampled channel with 50 kHz full-scale input to the channel being sampled with DC input (memory crosstalk).

### 8.5.1.1 Equivalent circuit for ADC inputs

The following figure shows the ADC input circuit during sample and hold. S1 and S2 are always opened/closed at non-overlapping phases, and both S1 and S2 are dependent on the ADC clock frequency. The following equation gives equivalent input impedance when the input is selected.

$$\frac{1}{(\text{ADC ClockRate}) \times C_{\text{ADI}}} + 50 \text{ ohm} + \text{Resistor}$$

#### NOTE

Resistor=1200 ohm@gain1×, or 730 ohm@gain2×, or 500 ohm@gain4×



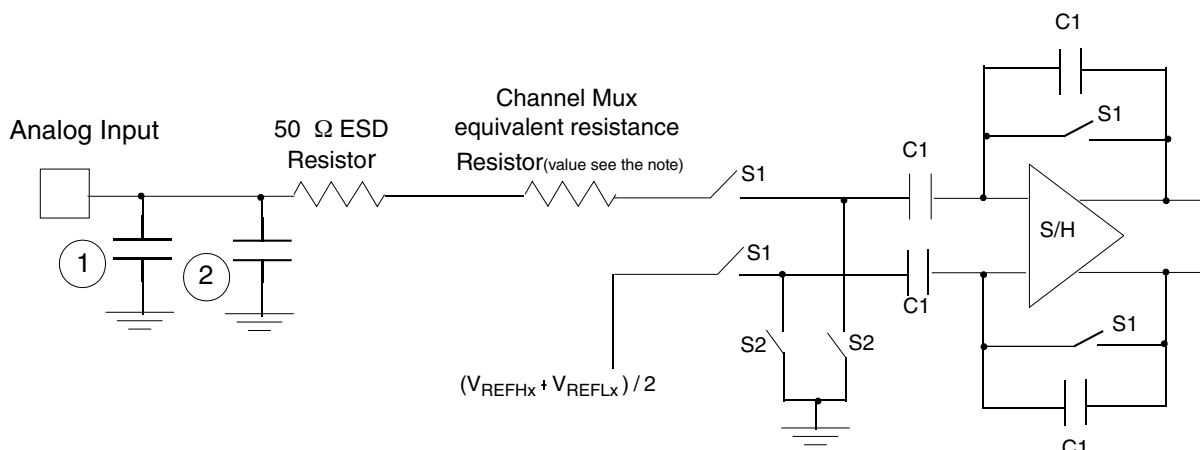

1. Parasitic capacitance due to package, pin-to-pin and pin-to-package base coupling = 1.8pF
2. Parasitic capacitance due to the chip bond pad, ESD protection devices and signal routing = 2.04pF
3. S1 and S2 switch phases are non-overlapping and depend on the ADC clock frequency

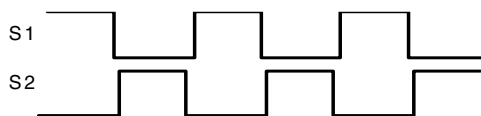

Figure 12. Equivalent circuit for A/D loading

## 8.5.2 12-bit Digital-to-Analog Converter (DAC) parameters

### NOTE

RLD = 3 kΩ and CLD = 400 pF, unless otherwise specified.

Table 29. DAC parameters

Parameter	Conditions/Comments	Symbol	Min	Typ	Max	Unit
<b>DC Specifications</b>						
Resolution			12	12	12	bits
Settling time <sup>1</sup>	At output load RLD = 3 kΩ CLD = 400 pF Range of input digital words: 410 to 3891		—	1 (high-speed mode) 2 (low-speed mode)		μs

Table continues on the next page...

**Table 29. DAC parameters (continued)**

Parameter	Conditions/Comments	Symbol	Min	Typ	Max	Unit
Power-up time	Time from release of PWRDWN signal until DACOUT signal is valid	$t_{DAPU}$	—	—	11	$\mu\text{s}$
<b>Accuracy</b>						
Integral non-linearity	Range of input digital words: 410 to 3891 (\$19A - \$F33)	INL	—	+/- 3	+/- 4	LSB
Differential non-linearity	Range of input digital words: 410 to 3891 (\$19A - \$F33)	DNL	—	+/- 0.5	+/- 1	LSB
Monotonicity	> 6 sigma monotonicity, < 3.4 ppm non-monotonicity		guaranteed			—
Offset error	Range of input digital words: 410 to 3891 (\$19A - \$F33)	$V_{\text{OFFSET}}$	—	+/- 25	+/- 43	mV
Gain error	Range of input digital words: 410 to 3891 (\$19A - \$F33)	$E_{\text{GAIN}}$	—	+/- 0.5	+/- 1.5	%
<b>DAC Output</b>						
Output voltage range	Within 40 mV of either $V_{\text{SSA}}$ or $V_{\text{DDA}}$	$V_{\text{OUT}}$	$V_{\text{SSA}} + 0.04 \text{ V}$	—	$V_{\text{DDA}} - 0.04 \text{ V}$	V
<b>AC Specifications</b>						
Signal-to-noise ratio		SNR	—	80	—	dB
Spurious free dynamic range		SFDR	—	-72	—	dB
Effective number of bits		ENOB	—	10	—	bits
$I_{\text{DD}}$ from $V_{\text{DDA}}$	average $I_{\text{DD}}$ of $V_{\text{DDA}}$ ( $I_{\text{DD}}$ varies with DAC input word)	$I_{\text{DDA}}$	—	3.2	—	mA

1. When DAC output is fed to other internal peripherals, the settling time is much shorter.

### 8.5.3 OPAMP electrical specifications

**Table 30. OPAMP electrical specifications**

Symbol	Description	Min.	Typ.	Max.	Unit
$V_{\text{CC}}$	Power supply	3.0	—	3.6	V
$I_{\text{CC}}$	Supply current <ul style="list-style-type: none"> <li>• high-speed mode</li> <li>• low-power mode</li> </ul>	—	500	—	$\mu\text{A}$
$V_{\text{OS}}$	Input offset voltage <ul style="list-style-type: none"> <li>• high-speed mode</li> <li>• low-power mode</li> </ul>	—	$\pm 1.5$	$\pm 5$	mV
		—	$\pm 2$	$\pm 6.5$	

Table continues on the next page...

**Table 30. OPAMP electrical specifications (continued)**

Symbol	Description	Min.	Typ.	Max.	Unit
V <sub>IN</sub>	Common input voltage	VSSA	—	VDDA - 1.2	V
V <sub>OUT</sub>	Output voltage range	0.15	—	VDDA - 0.15	V
CMRR	Input common mode rejection ratio	60	80	—	dB
PSRR	Power supply rejection ratio	60	80	—	dB
SR	Slew rate <sup>1</sup> <ul style="list-style-type: none"> <li>• high-speed mode</li> <li>• low-power mode</li> </ul>	4	8	—	V/μs
GBW	Unity gain bandwidth <sup>1</sup> <ul style="list-style-type: none"> <li>• high-speed mode</li> <li>• low-power mode</li> </ul>	—	8	—	MHz
			1.5		

1. R<sub>L</sub> = 5 ~ 10 kΩ, C<sub>L</sub> = 30 ~ 50 pf

## 8.5.4 CMP and 8-bit DAC electrical specifications

**Table 31. Comparator and 8-bit DAC electrical specifications**

Symbol	Description	Min.	Typ.	Max.	Unit
V <sub>DD</sub>	Supply voltage	3.0	—	3.6	V
I <sub>DDHS</sub>	Supply current, high-speed mode (EN=1, PMODE=1)	—	300	—	μA
I <sub>DDL</sub>	Supply current, low-speed mode (EN=1, PMODE=0)	—	36	—	μA
V <sub>Ain</sub>	Analog input voltage	V <sub>SS</sub>	—	V <sub>DD</sub>	V
V <sub>AIO</sub>	Analog input offset voltage <sup>1</sup>	—	—	20	mV
V <sub>H</sub>	Analog comparator hysteresis <ul style="list-style-type: none"> <li>• CR0[HYSTCTR] = 00<sup>2</sup></li> <li>• CR0[HYSTCTR] = 01<sup>1</sup></li> <li>• CR0[HYSTCTR] = 10<sup>1</sup></li> <li>• CR0[HYSTCTR] = 11<sup>1</sup></li> </ul>	—	5	13	mV
		—	25	48	mV
		—	55	105	mV
		—	80	148	mV
V <sub>CMPOh</sub>	Output high	V <sub>DD</sub> - 0.5	—	—	V
V <sub>CMPOl</sub>	Output low	—	—	0.5	V
t <sub>DHS</sub>	Propagation delay, high-speed mode (EN=1, PMODE=1) <sup>3</sup>	—	25	70	ns
t <sub>DLS</sub>	Propagation delay, low-speed mode (EN=1, PMODE=0) <sup>3</sup>	—	60	200	ns
	Analog comparator initialization delay <sup>4</sup>	—	40	—	μs
I <sub>DAC8b</sub>	8-bit DAC current adder (enabled)	—	7	—	μA
V <sub>reference</sub>	8-bit DAC reference inputs, Vin1 and Vin2	—	V <sub>DD</sub>	—	V

Table continues on the next page...

**Table 31. Comparator and 8-bit DAC electrical specifications (continued)**

Symbol	Description	Min.	Typ.	Max.	Unit
	There are two reference input options selectable (via VRSEL control bit). The reference options must fall within this range.				
INL	8-bit DAC integral non-linearity	-1	—	1	LSB <sup>5</sup>
DNL	8-bit DAC differential non-linearity	-1	—	1	LSB

1. Measured with input voltage range limited to  $0.7 \leq V_{in} \leq V_{DD} - 0.8$
2. Measured with input voltage range limited to 0 to  $V_{DD}$
3. Input voltage range:  $0.1V_{DD} \leq V_{in} \leq 0.9V_{DD}$ , step =  $\pm 100\text{mV}$ , across all temperature. Does not include PCB and PAD delay.
4. Comparator initialization delay is defined as the time of switching the comparator from the disabled state to the enabled state, with the comparator output settling to a stable level.
5.  $1 \text{ LSB} = V_{\text{reference}}/256$

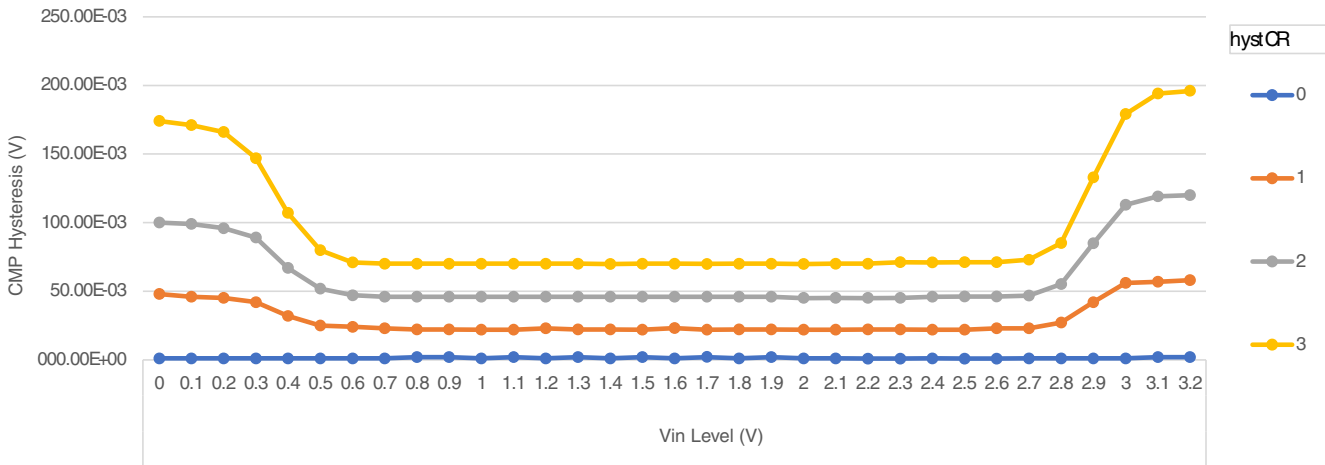

**Figure 13. Typical hysteresis vs. Vin level ( $V_{DD} = 3.3 \text{ V}$ ,  $\text{PMODE} = 0$ )**

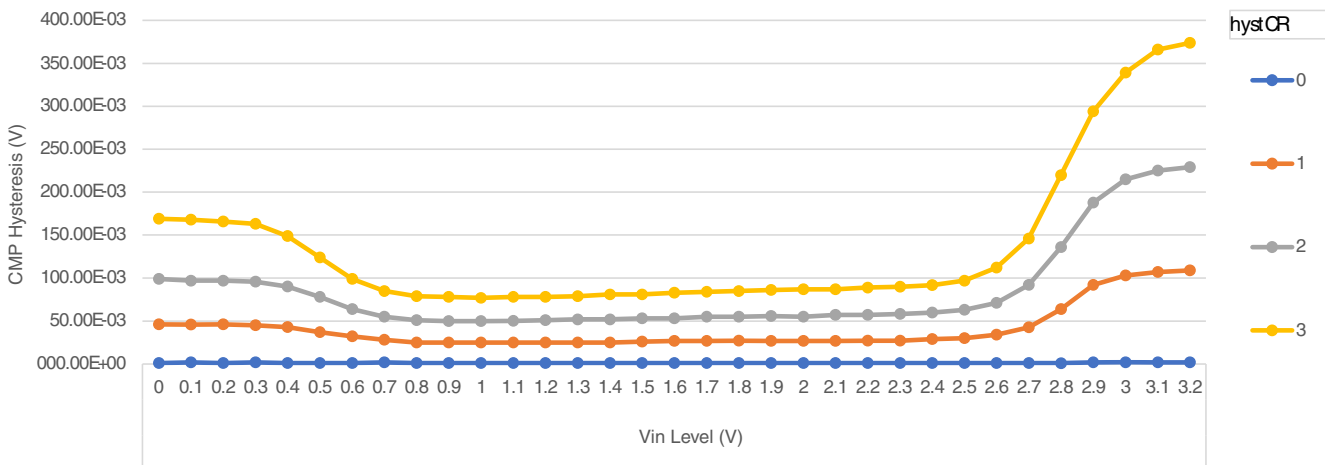

**Figure 14. Typical hysteresis vs. Vin level ( $V_{DD} = 3.3 \text{ V}$ ,  $\text{PMODE} = 1$ )**

## 8.6 PWMs and timers

### 8.6.1 Enhanced NanoEdge PWM characteristics

**Table 32. NanoEdge PWM timing parameters**

Characteristic	Symbol	Min	Typ	Max	Unit
PWM clock frequency			100		MHz
NanoEdge Placement (NEP) Step Size <sup>1,2</sup>	pwmp		312		ps
Delay for fault input activating to PWM output deactivated		1		33	ns
Power-up Time <sup>3</sup>	$t_{pu}$		25		$\mu$ s
Resolution of Deadtime			312		ps

1. Reference IPbus clock of 100 MHz in NanoEdge Placement mode.
2. Temperature and voltage variations do not affect NanoEdge Placement step size.
3. Powerdown to NanoEdge mode transition.

### 8.6.2 Quad Timer timing

Parameters listed are guaranteed by design.

**Table 33. Timer timing**

Characteristic	Symbol	Min <sup>1</sup>	Max	Unit	See Figure
Timer input period	$P_{IN}$	$2T + 6$	—	ns	<a href="#">Figure 15</a>
Timer input high/low period	$P_{INHL}$	$1T + 3$	—	ns	<a href="#">Figure 15</a>
Timer output period	$P_{OUT}$	20	—	ns	<a href="#">Figure 15</a>
Timer output high/low period	$P_{OUTH}$	10	—	ns	<a href="#">Figure 15</a>

1.  $T$  = clock cycle. For 100 MHz operation,  $T$  = 10 ns.

## PWMs and timers

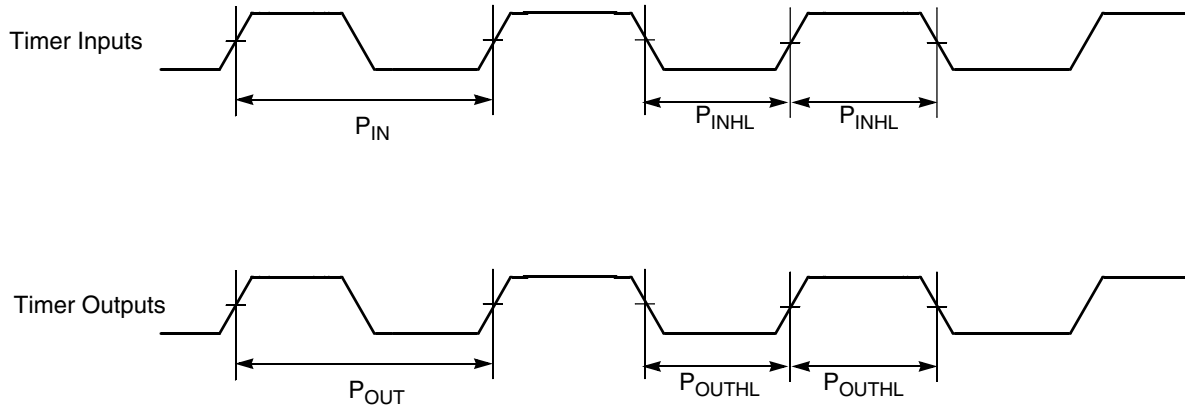

Figure 15. Timer timing

## 8.7 Communication interfaces

### 8.7.1 Queued Serial Peripheral Interface (SPI) timing

Parameters listed are guaranteed by design.

Table 34. SPI timing

Characteristic	Symbol	Min	Max	Unit	See Figure
Cycle time	$t_c$	60	—	ns	Figure 16
Master		60	—	ns	Figure 17
Slave					Figure 18 Figure 19
Enable lead time	$t_{ELD}$	—	—	ns	Figure 19
Master		20	—	ns	
Slave					
Enable lag time	$t_{ELG}$	—	—	ns	Figure 19
Master		20	—	ns	
Slave					
Clock (SCK) high time	$t_{CH}$		—	ns	Figure 16
Master			—	ns	Figure 17
Slave					Figure 18 Figure 19
Clock (SCK) low time	$t_{CL}$	28	—	ns	Figure 19
Master		28	—	ns	
Slave					

Table continues on the next page...

**Table 34. SPI timing (continued)**

Characteristic	Symbol	Min	Max	Unit	See Figure
Data set-up time required for inputs	$t_{DS}$	20	—	ns	<a href="#">Figure 16</a> <a href="#">Figure 17</a> <a href="#">Figure 18</a> <a href="#">Figure 19</a>
Master		1	—	ns	
Slave					
Data hold time required for inputs	$t_{DH}$	1	—	ns	
Master		3	—	ns	
Slave					
Access time (time to data active from high-impedance state)	$t_A$	5	—	ns	<a href="#">Figure 19</a>
Slave					
Disable time (hold time to high-impedance state)	$t_D$	5	—	ns	<a href="#">Figure 19</a>
Slave					
Data valid for outputs	$t_{DV}$	—		ns	<a href="#">Figure 16</a> <a href="#">Figure 17</a> <a href="#">Figure 18</a> <a href="#">Figure 19</a>
Master		—		ns	
Slave (after enable edge)					
Data invalid	$t_{DI}$	0	—	ns	
Master		0	—	ns	
Slave					
Rise time	$t_R$	—	1	ns	<a href="#">Figure 16</a> <a href="#">Figure 17</a> <a href="#">Figure 18</a> <a href="#">Figure 19</a>
Master		—	1	ns	
Slave					
Fall time	$t_F$	—	1	ns	
Master		—	1	ns	
Slave					

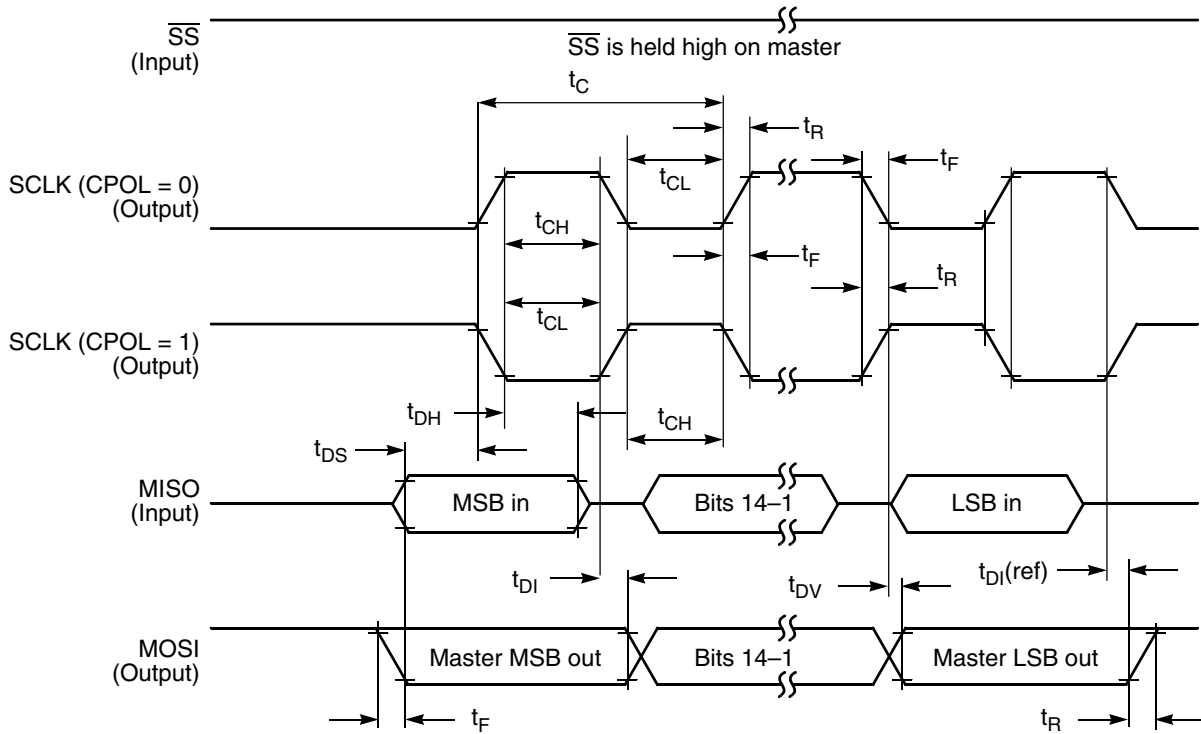

Figure 16. SPI master timing (CPHA = 0)

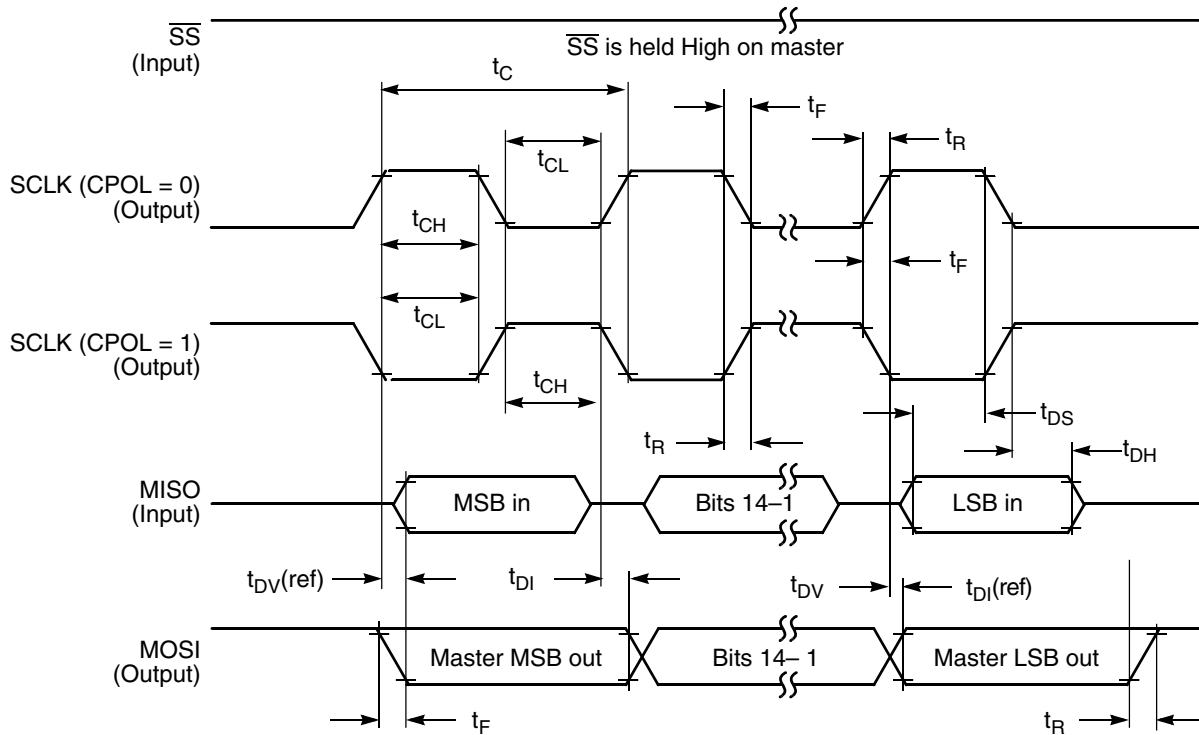

Figure 17. SPI master timing (CPHA = 1)



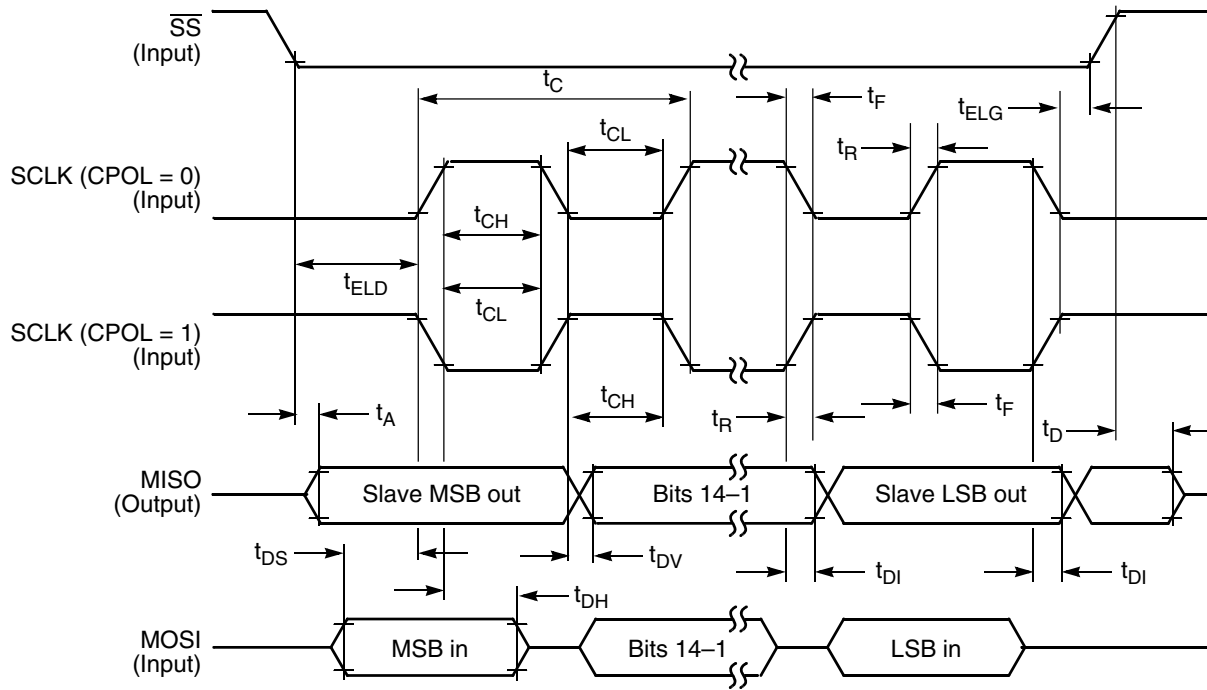

Figure 18. SPI slave timing (CPHA = 0)

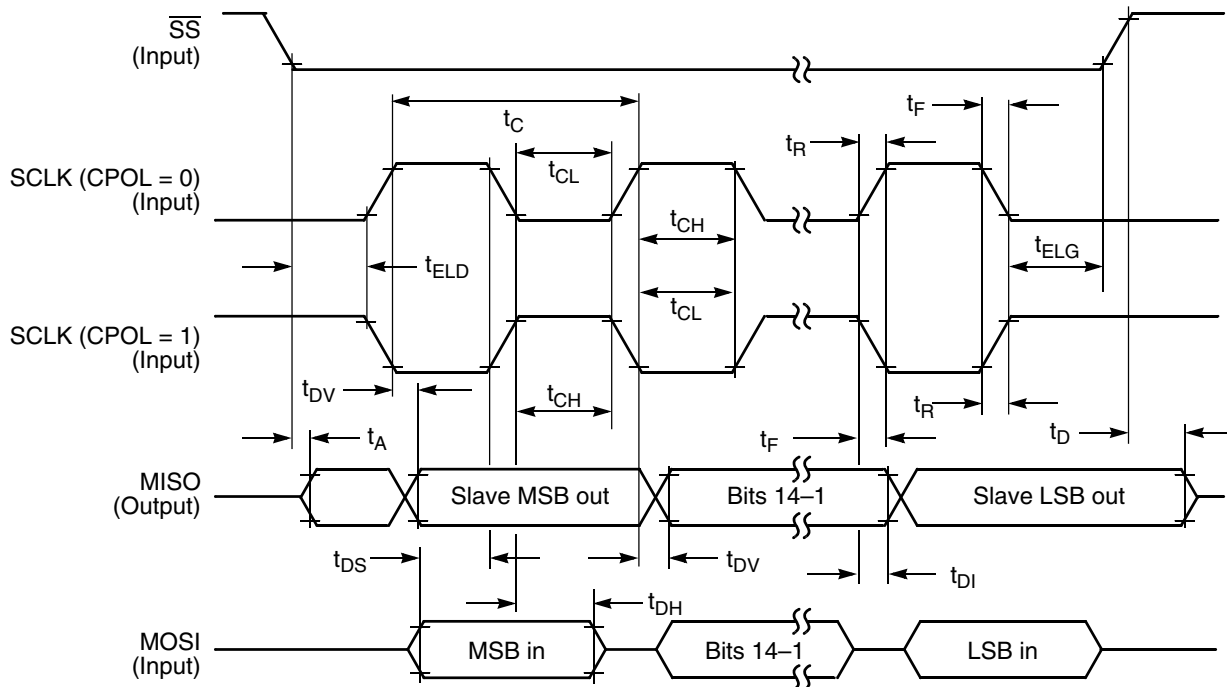

Figure 19. SPI slave timing (CPHA = 1)

### 8.7.2 Queued Serial Communication Interface (SCI) timing

Parameters listed are guaranteed by design.

**Table 35. SCI timing**

Characteristic	Symbol	Min	Max	Unit	See Figure
Baud rate <sup>1</sup>	BR	—	(f <sub>MAX</sub> /16)	Mbit/s	—
RXD pulse width	RXD <sub>PW</sub>	0.965/BR	1.04/BR	μs	Figure 20
TXD pulse width	TXD <sub>PW</sub>	0.965/BR	1.04/BR	μs	Figure 21
LIN Slave Mode					
Deviation of slave node clock from nominal clock rate before synchronization	F <sub>TOL_UNSYNC H</sub>	-14	14	%	—
Deviation of slave node clock relative to the master node clock after synchronization	F <sub>TOL_SYNC H</sub>	-2	2	%	—
Minimum break character length	T <sub>BREAK</sub>	13	—	Master node bit periods	—
		11	—	Slave node bit periods	—

- f<sub>MAX</sub> is the frequency of operation of the SCI clock in MHz, which can be selected as the bus clock (max.50 MHz depending on part number) or 2x bus clock (max. 100 MHz) for the devices.

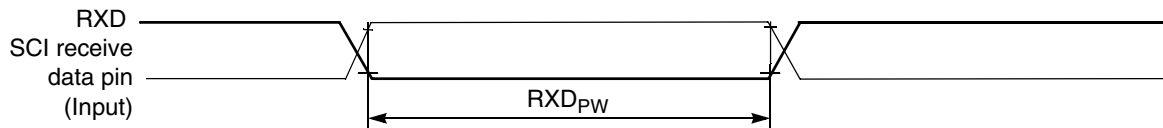

**Figure 20. RXD pulse width**

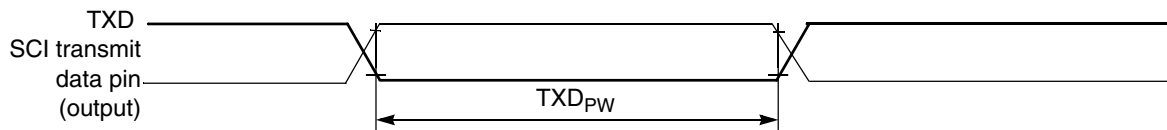

**Figure 21. TXD pulse width**

### 8.7.3 LPI<sup>2</sup>C

**Table 36. LPI<sup>2</sup>C specifications**

Symbol	Description		Min.	Max.	Unit	Notes
f <sub>SCL</sub>	SCL clock frequency	Standard mode (Sm)	0	100	kHz	1, 2, 3

Table continues on the next page...

**Table 36. I<sup>2</sup>C specifications (continued)**

Symbol	Description	Min.	Max.	Unit	Notes
	Fast mode (Fm)	0	400		
	Fast mode Plus (Fm+)	0	1000		
	Ultra Fast mode (UFm)	0	5000		
	High speed mode (Hs-mode)	0	3400		

1. Hs-mode is only supported in slave mode.
2. The maximum SCL clock frequency in Fast mode with maximum bus loading (400pF) can only be achieved with appropriate pull-up devices on the bus when using the high or normal drive pins across the full voltage range . The maximum SCL clock frequency in Fast mode Plus can support maximum bus loading (400pF) with appropriate pull-up devices when using the high drive pins. The maximum SCL clock frequency in Ultra Fast mode can support maximum bus loading (400pF) when using the high drive pins. The maximum SCL clock frequency for slave in High speed mode can support maximum bus loading (400pF) with appropriate pull-up devices when using the high drive pins. For more information on the required pull-up devices, see I<sup>2</sup>C Bus Specification.
3. See the section "General switching specifications".

## 9 Design Considerations

### 9.1 Thermal design considerations

An estimate of the chip junction temperature ( $T_J$ ) can be obtained from the equation:

$$T_J = T_A + (R_{\Theta JA} \times P_D)$$

where

$T_A$  = Ambient temperature for the package (°C)

$R_{\Theta JA}$  = Junction-to-ambient thermal resistance (°C/W)

$P_D$  = Power dissipation in the package (W).

The junction-to-ambient thermal resistance is an industry-standard value that provides a quick and easy estimation of thermal performance. Unfortunately, there are two values in common usage: the value determined on a single-layer board and the value obtained on a board with two planes. For packages such as the PBGA, these values can be different by a factor of two. Which  $T_J$  value is closer to the application depends on the power dissipated by other components on the board.

- The  $T_J$  value obtained on a single layer board is appropriate for a tightly packed printed circuit board.
- The  $T_J$  value obtained on a board with the internal planes is usually appropriate if the board has low-power dissipation and if the components are well separated.

## Design Considerations

When a heat sink is used, the thermal resistance is expressed as the sum of a junction-to-case thermal resistance and a case-to-ambient thermal resistance:

$$R_{\Theta JA} = R_{\Theta JC} + R_{\Theta CA}$$

where

$R_{\Theta JA}$  = Package junction-to-ambient thermal resistance ( $^{\circ}\text{C}/\text{W}$ )

$R_{\Theta JC}$  = Package junction-to-case thermal resistance ( $^{\circ}\text{C}/\text{W}$ )

$R_{\Theta CA}$  = Package case-to-ambient thermal resistance ( $^{\circ}\text{C}/\text{W}$ ).

$R_{\Theta JC}$  is device related and cannot be adjusted. You control the thermal environment to change the case to ambient thermal resistance,  $R_{\Theta CA}$ . For instance, you can change the size of the heat sink, the air flow around the device, the interface material, the mounting arrangement on printed circuit board, or change the thermal dissipation on the printed circuit board surrounding the device.

**To determine the junction temperature of the device in the application when heat sinks are not used**, the thermal characterization parameter ( $\Psi_{JT}$ ) can be used to determine the junction temperature with a measurement of the temperature at the top center of the package case using the following equation:

$$T_J = T_T + (\Psi_{JT} \times P_D)$$

where

$T_T$  = Thermocouple temperature on top of package ( $^{\circ}\text{C}/\text{W}$ )

$\Psi_{JT}$  = Thermal characterization parameter ( $^{\circ}\text{C}/\text{W}$ )

$P_D$  = Power dissipation in package (W).

The thermal characterization parameter is measured per JESD51–2 specification using a 40-gauge type T thermocouple epoxied to the top center of the package case. The thermocouple should be positioned so that the thermocouple junction rests on the package. A small amount of epoxy is placed over the thermocouple junction and over about 1 mm of wire extending from the junction. The thermocouple wire is placed flat against the package case to avoid measurement errors caused by cooling effects of the thermocouple wire.

**To determine the junction temperature of the device in the application when heat sinks are used**, the junction temperature is determined from a thermocouple inserted at the interface between the case of the package and the interface material. A clearance slot or hole is normally required in the heat sink. Minimizing the size of the clearance is important to minimize the change in thermal performance caused by removing part of

the thermal interface to the heat sink. Because of the experimental difficulties with this technique, many engineers measure the heat sink temperature and then back-calculate the case temperature using a separate measurement of the thermal resistance of the interface. From this case temperature, the junction temperature is determined from the junction-to-case thermal resistance.

## 9.2 Electrical design considerations

### CAUTION

This device contains protective circuitry to guard against damage due to high static voltage or electrical fields. However, take normal precautions to avoid application of any voltages higher than maximum-rated voltages to this high-impedance circuit. Reliability of operation is enhanced if unused inputs are tied to an appropriate voltage level.

Use the following list of considerations to assure correct operation of the device:

- Provide a low-impedance path from the board power supply to each  $V_{DD}$  pin on the device and from the board ground to each  $V_{SS}$  (GND) pin.
- The minimum bypass requirement is to place 0.01–0.1  $\mu\text{F}$  capacitors positioned as near as possible to the package supply pins. The recommended bypass configuration is to place one bypass capacitor on each of the  $V_{DD}/V_{SS}$  pairs, including  $V_{DDA}/V_{SSA}$ . Ceramic and tantalum capacitors tend to provide better tolerances.
- Ensure that capacitor leads and associated printed circuit traces that connect to the chip  $V_{DD}$  and  $V_{SS}$  (GND) pins are as short as possible.
- Bypass the  $V_{DD}$  and  $V_{SS}$  with approximately 100  $\mu\text{F}$ , plus the number of 0.1  $\mu\text{F}$  ceramic capacitors.
- PCB trace lengths should be minimal for high-frequency signals.
- Consider all device loads as well as parasitic capacitance due to PCB traces when calculating capacitance. This is especially critical in systems with higher capacitive loads that could create higher transient currents in the  $V_{DD}$  and  $V_{SS}$  circuits.
- Take special care to minimize noise levels on the  $V_{REF}$ ,  $V_{DDA}$ , and  $V_{SSA}$  pins.
- Using separate power planes for  $V_{DD}$  and  $V_{DDA}$  and separate ground planes for  $V_{SS}$  and  $V_{SSA}$  are recommended. Connect the separate analog and digital power and ground planes as near as possible to power supply outputs. If an analog circuit and digital circuit are powered by the same power supply, then connect a small inductor or ferrite bead in serial with  $V_{DDA}$ . Traces of  $V_{SS}$  and  $V_{SSA}$  should be shorted together.

## Design Considerations

- Physically separate analog components from noisy digital components by ground planes. Do not place an analog trace in parallel with digital traces. Place an analog ground trace around an analog signal trace to isolate it from digital traces.
- Because the flash memory is programmed through the JTAG/EOnCE port, SPI, SCI, or I<sup>2</sup>C, the designer should provide an interface to this port if in-circuit flash programming is desired.
- If desired, connect an external RC circuit to the  $\overline{\text{RESET}}$  pin. The resistor value should be in the range of 4.7 k $\Omega$ –10 k $\Omega$ ; the capacitor value should be in the range of 0.1  $\mu\text{F}$ –4.7  $\mu\text{F}$ .
- Configuring the  $\overline{\text{RESET}}$  pin to GPIO output in normal operation in a high-noise environment may help to improve the performance of noise transient immunity.
- Add a 2.2 k $\Omega$  external pullup on the TMS pin of the JTAG port to keep EOnCE in a reset state during normal operation if JTAG converter is not present. Furthermore, configure TMS, TDI, TDO and TCK to GPIO if operation environment is very noisy.
- During reset and after reset but before I/O initialization, all the GPIO pins are at tri-state.
- To eliminate PCB trace impedance effect, each ADC input should have a no less than 33 pF 10 $\Omega$  RC filter.

## 9.3 Power-on Reset design considerations

### 9.3.1 Improper power-up sequence between VDD/VSS and VDDA/VSSA:

It is recommended that VDD be kept within 100 mV of VDDA at all times, including power ramp-up and ramp-down. Failure to keep VDD within 100 mV of VDDA may cause a leakage current through the substrate, between the VDD and VDDA pad cells. This leakage current could prevent operation of the device after it powers up. The voltage difference between VDD and VDDA must be limited to below 0.3 V at all times, to avoid permanent damage to the part (See the table in "Voltage and current operating ratings" section). Also see the table in "Voltage and current operating requirements" section.

### 9.3.2 Heavy capacitive load on power supply output:

In some applications, the low cost DC/DC converter may not regulate the output voltage well before it reaches the regulation point, which is roughly around 2.5V to 2.7V. However, the device might exit power-on reset at around 2.3V. If the initialization code enables the PLL to run the DSC at full speed right after reset, then the high current will be pulled by DSC from the supply, which can cause the supply voltage to drop below the operation voltage; see the captured graph (Figure 22). This can cause the DSC fail to start up.



**Figure 22. Supply Voltage Drop**

A recommended initialization sequence during power-up is:

1. After POR is released, run a few hundred NOP instructions from the internal relaxation oscillator; this gives time for the supply voltage to stabilize.
2. Configure the peripherals (except the ADC) to the desired settings; the ADC should stay in low power mode.
3. Power up the PLL.
4. After the PLL locks, switch the clock from PLL prescale to postscale.
5. Configure the ADC.

## 10 Obtaining package dimensions

Package dimensions are provided in package drawings.

To find a package drawing, go to [nxp.com](http://nxp.com) and perform a keyword search for the drawing's document number:

## Release Notes

Drawing for package	Document number to be used
64-pin LQFP	98ASS23234W

## Release Notes

### A.1 Revision history

The following table provides a revision history for this document.

**Table A-1. Revision history**

Rev.	Date	Substantial Changes
2.1	05/2024	Initial public release. <ul style="list-style-type: none"><li>• Minor update in the cover page about supporting WPC's BPP, EPP and MPP.</li><li>• Minor update in Figure 1, Figure 2, and updated the Figure 3 as "MPP wireless charging single-transmitter system functional diagram (example)".</li></ul>
2	12/2023	Alpha customer release



## Legal information

### Data sheet status

Document status <sup>[1][2]</sup>	Product status <sup>[3]</sup>	Definition
Objective [short] data sheet	Development	This document contains data from the objective specification for product development.
Preliminary [short] data sheet	Qualification	This document contains data from the preliminary specification.
Product [short] data sheet	Production	This document contains the product specification.

[1] Please consult the most recently issued document before initiating or completing a design.

[2] The term 'short data sheet' is explained in section "Definitions".

[3] The product status of device(s) described in this document may have changed since this document was published and may differ in case of multiple devices. The latest product status information is available on the Internet at URL <http://www.nxp.com>.

### Definitions

**Draft** — A draft status on a document indicates that the content is still under internal review and subject to formal approval, which may result in modifications or additions. NXP Semiconductors does not give any representations or warranties as to the accuracy or completeness of information included in a draft version of a document and shall have no liability for the consequences of use of such information.

**Short data sheet** — A short data sheet is an extract from a full data sheet with the same product type number(s) and title. A short data sheet is intended for quick reference only and should not be relied upon to contain detailed and full information. For detailed and full information see the relevant full data sheet, which is available on request via the local NXP Semiconductors sales office. In case of any inconsistency or conflict with the short data sheet, the full data sheet shall prevail.

**Product specification** — The information and data provided in a Product data sheet shall define the specification of the product as agreed between NXP Semiconductors and its customer, unless NXP Semiconductors and customer have explicitly agreed otherwise in writing. In no event however, shall an agreement be valid in which the NXP Semiconductors product is deemed to offer functions and qualities beyond those described in the Product data sheet.

### Disclaimers

**Limited warranty and liability** — Information in this document is believed to be accurate and reliable. However, NXP Semiconductors does not give any representations or warranties, expressed or implied, as to the accuracy or completeness of such information and shall have no liability for the consequences of use of such information. NXP Semiconductors takes no responsibility for the content in this document if provided by an information source outside of NXP Semiconductors.

In no event shall NXP Semiconductors be liable for any indirect, incidental, punitive, special or consequential damages (including - without limitation - lost profits, lost savings, business interruption, costs related to the removal or replacement of any products or rework charges) whether or not such damages are based on tort (including negligence), warranty, breach of contract or any other legal theory.

Notwithstanding any damages that customer might incur for any reason whatsoever, NXP Semiconductors' aggregate and cumulative liability towards customer for the products described herein shall be limited in accordance with the Terms and conditions of commercial sale of NXP Semiconductors.

**Right to make changes** — NXP Semiconductors reserves the right to make changes to information published in this document, including without limitation specifications and product descriptions, at any time and without notice. This document supersedes and replaces all information supplied prior to the publication hereof.

**Applications** — Applications that are described herein for any of these products are for illustrative purposes only. NXP Semiconductors makes no representation or warranty that such applications will be suitable for the specified use without further testing or modification.

Customers are responsible for the design and operation of their applications and products using NXP Semiconductors products, and NXP Semiconductors accepts no liability for any assistance with applications or customer product design. It is customer's sole responsibility to determine whether the NXP Semiconductors product is suitable and fit for the customer's applications and products planned, as well as for the planned application and use of customer's third party customer(s). Customers should provide appropriate design and operating safeguards to minimize the risks associated with their applications and products.

NXP Semiconductors does not accept any liability related to any default, damage, costs or problem which is based on any weakness or default in the customer's applications or products, or the application or use by customer's third party customer(s). Customer is responsible for doing all necessary testing for the customer's applications and products using NXP Semiconductors products in order to avoid a default of the applications and the products or of the application or use by customer's third party customer(s). NXP does not accept any liability in this respect.

**Limiting values** — Stress above one or more limiting values (as defined in the Absolute Maximum Ratings System of IEC 60134) will cause permanent damage to the device. Limiting values are stress ratings only and (proper) operation of the device at these or any other conditions above those given in the Recommended operating conditions section (if present) or the Characteristics sections of this document is not warranted. Constant or repeated exposure to limiting values will permanently and irreversibly affect the quality and reliability of the device.

**Terms and conditions of commercial sale** — NXP Semiconductors products are sold subject to the general terms and conditions of commercial sale, as published at <http://www.nxp.com/profile/terms>, unless otherwise agreed in a valid written individual agreement. In case an individual agreement is concluded only the terms and conditions of the respective agreement shall apply. NXP Semiconductors hereby expressly objects to applying the customer's general terms and conditions with regard to the purchase of NXP Semiconductors products by customer.

**No offer to sell or license** — Nothing in this document may be interpreted or construed as an offer to sell products that is open for acceptance or the grant, conveyance or implication of any license under any copyrights, patents or other industrial or intellectual property rights.

**Suitability for use in automotive applications** — This NXP product has been qualified for use in automotive applications. If this product is used by customer in the development of, or for incorporation into, products or services (a) used in safety critical applications or (b) in which failure could lead to death, personal injury, or severe physical or environmental damage (such products and services hereinafter referred to as "Critical Applications"), then customer makes the ultimate design decisions regarding its products and is solely responsible for compliance with all legal, regulatory, safety, and security related requirements concerning its products, regardless of any information or support that may be provided by NXP. As such, customer assumes all risk related to use of any products in Critical Applications and NXP and its suppliers shall not be liable for any such use by customer. Accordingly, customer will indemnify and hold NXP harmless from any claims, liabilities, damages and associated costs and expenses (including attorneys' fees) that NXP may incur related to customer's incorporation of any product in a Critical Application.

**Quick reference data** — The Quick reference data is an extract of the product data given in the Limiting values and Characteristics sections of this document, and as such is not complete, exhaustive or legally binding.

**Export control** — This document as well as the item(s) described herein may be subject to export control regulations. Export might require a prior authorization from competent authorities.

**Translations** — A non-English (translated) version of a document, including the legal information in that document, is for reference only. The English version shall prevail in case of any discrepancy between the translated and English versions.

**Security** — Customer understands that all NXP products may be subject to unidentified vulnerabilities or may support established security standards or specifications with known limitations. Customer is responsible for the design and operation of its applications and products throughout their lifecycles to reduce the effect of these vulnerabilities on customer's applications and products. Customer's responsibility also extends to other open and/or proprietary technologies supported by NXP products for use in customer's applications. NXP accepts no liability for any vulnerability. Customer should regularly check security updates from NXP and follow up appropriately.

Customer shall select products with security features that best meet rules, regulations, and standards of the intended application and make the ultimate design decisions regarding its products and is solely responsible for compliance with all legal, regulatory, and security related requirements concerning its products, regardless of any information or support that may be provided by NXP.

NXP has a Product Security Incident Response Team (PSIRT) (reachable at [PSIRT@nxp.com](mailto:PSIRT@nxp.com)) that manages the investigation, reporting, and solution release to security vulnerabilities of NXP products.

**NXP B.V.** — NXP B.V. is not an operating company and it does not distribute or sell products.

## Trademarks

Notice: All referenced brands, product names, service names, and trademarks are the property of their respective owners.

**NXP** — wordmark and logo are trademarks of NXP B.V.

**Freescale** — is a trademark of NXP B.V.

---

Please be aware that important notices concerning this document and the product(s) described herein, have been included in section 'Legal information'.

---

© NXP B.V. 2024.

All rights reserved.

For more information, please visit: <http://www.nxp.com>

For sales office addresses, please send an email to: [salesaddresses@nxp.com](mailto:salesaddresses@nxp.com)

Date of release: 05/2024

Document identifier: MWCT2XX2A