

# IGBT Modules

## Sixpack

Short Circuit SOA Capability  
Square RBSOA

$I_{C25} = 130 \text{ A}$   
 $V_{CES} = 600 \text{ V}$   
 $V_{CE(sat) \text{ typ.}} = 2.0 \text{ V}$

Preliminary data

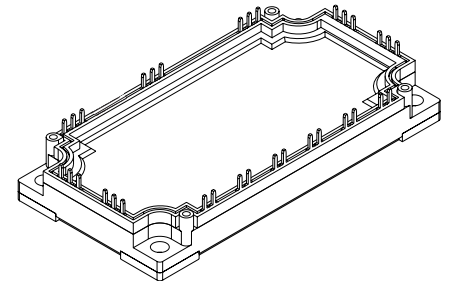
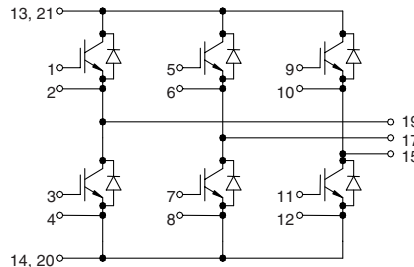

IGBTs			
Symbol	Conditions	Maximum Ratings	
$V_{CES}$	$T_{VJ} = 25^{\circ}\text{C to } 150^{\circ}\text{C}$	600	V
$V_{GES}$		$\pm 20$	V
$I_{C25}$	$T_C = 25^{\circ}\text{C}$	130	A
$I_{C80}$	$T_C = 80^{\circ}\text{C}$	88	A
<b>RBSOA</b>	$V_{GE} = \pm 15 \text{ V}; R_G = 2.2 \Omega; T_{VJ} = 125^{\circ}\text{C}$ Clamped inductive load; $L = 100 \mu\text{H}$	$I_{CM} = 200$ $V_{CEK} \leq V_{CES}$	A
$t_{SC}$ <b>(SCSOA)</b>	$V_{CE} = V_{CES}; V_{GE} = \pm 15 \text{ V}; R_G = 2.2 \Omega; T_{VJ} = 125^{\circ}\text{C}$ non-repetitive	10	$\mu\text{s}$
$P_{tot}$	$T_C = 25^{\circ}\text{C}$	410	W

### Features

- NPT IGBT technology
- low saturation voltage
- low switching losses
- switching frequency up to 30 kHz
- square RBSOA, no latch up
- high short circuit capability
- positive temperature coefficient for easy paralleling
- MOS input, voltage controlled
- ultra fast free wheeling diodes
- solderable pins for PCB mounting
- package with copper base plate

### Advantages

- space savings
- reduced protection circuits
- package designed for wave soldering

### Typical Applications

- AC motor control
- AC servo and robot drives
- power supplies

Symbol	Conditions	Characteristic Values ( $T_{VJ} = 25^{\circ}\text{C}$ , unless otherwise specified)			
		min.	typ.	max.	
$V_{CE(sat)}$	$I_C = 100 \text{ A}; V_{GE} = 15 \text{ V}; T_{VJ} = 25^{\circ}\text{C}$ $T_{VJ} = 125^{\circ}\text{C}$		2.0 2.3	V V	
$V_{GE(th)}$	$I_C = 1.5 \text{ mA}; V_{GE} = V_{CE}$	4.5		6.5 V	
$I_{CES}$	$V_{CE} = V_{CES}; V_{GE} = 0 \text{ V}; T_{VJ} = 25^{\circ}\text{C}$ $T_{VJ} = 125^{\circ}\text{C}$		0.9	1.2 mA mA	
$I_{GES}$	$V_{CE} = 0 \text{ V}; V_{GE} = \pm 20 \text{ V}$			400 nA	
$t_{d(on)}$ $t_r$ $t_{d(off)}$ $t_f$ $E_{on}$ $E_{off}$	Inductive load, $T_{VJ} = 125^{\circ}\text{C}$ $V_{CE} = 300 \text{ V}; I_C = 100 \text{ A}$ $V_{GE} = \pm 15 \text{ V}; R_G = 2.2 \Omega$		25 11 150 30 1.0 2.9	ns ns ns ns mJ mJ	
$C_{ies}$		$V_{CE} = 25 \text{ V}; V_{GE} = 0 \text{ V}; f = 1 \text{ MHz}$		4.3	nF
$Q_{Gon}$		$V_{CE} = 300 \text{ V}; V_{GE} = 15 \text{ V}; I_C = 125 \text{ A}$		340	nC
$R_{thJC}$		(per IGBT)			0.3 K/W

IXYS reserves the right to change limits, test conditions and dimensions.

© 2003 IXYS All rights reserved

### Diodes

Symbol	Conditions	Maximum Ratings	
$I_{F25}$	$T_C = 25^\circ\text{C}$	140	A
$I_{F80}$	$T_C = 80^\circ\text{C}$	88	A

Symbol	Conditions	Characteristic Values		
		min.	typ.	max.
$V_F$	$I_F = 100\text{ A}; V_{GE} = 0\text{ V}; T_{VJ} = 25^\circ\text{C}$ $T_{VJ} = 125^\circ\text{C}$	1.9	2.1	V
$I_{RM}$ $t_{rr}$	$I_F = 60\text{ A}; di_F/dt = -500\text{ A}/\mu\text{s}; T_{VJ} = 125^\circ\text{C}$ $V_R = 300\text{ V}; V_{GE} = 0\text{ V}$	28		A
		100		ns
$R_{thJC}$	(per diode)			0.61 K/W

### Module

Symbol	Conditions	Maximum Ratings	
$T_{VJ}$	operating	-40...+125	$^\circ\text{C}$
$T_{JM}$		+150	$^\circ\text{C}$
$T_{stg}$		-40...+125	$^\circ\text{C}$
$V_{ISOL}$	$I_{ISOL} \leq 1\text{ mA}; 50/60\text{ Hz}$	2500	V~
$M_d$	Mounting torque (M5)	3 - 6	Nm

Symbol	Conditions	Characteristic Values		
		min.	typ.	max.
$R_{pin-chip}$			1.8	m $\Omega$
$d_s$	Creepage distance on surface	10		mm
$d_A$	Strike distance in air	10		mm
$R_{thCH}$	with heatsink compound		0.01	K/W
Weight		300		g

### Equivalent Circuits for Simulation

#### Conduction

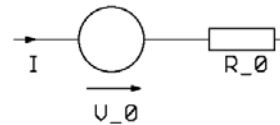

IGBT (typ. at  $V_{GE} = 15\text{ V}; T_J = 125^\circ\text{C}$ )  
 $V_0 = 1.1\text{ V}; R_0 = 12\text{ m}\Omega$

Free Wheeling Diode (typ. at  $T_J = 125^\circ\text{C}$ )  
 $V_0 = 1.15\text{ V}; R_0 = 2.5\text{ m}\Omega$

#### Thermal Response

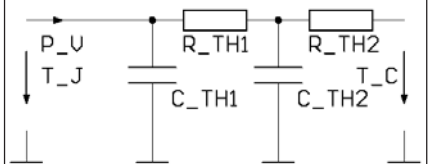

IGBT (typ.)  
 $C_{th1} = 0.232\text{ J/K}; R_{th1} = 0.223\text{ K/W}$   
 $C_{th2} = 1.504\text{ J/K}; R_{th2} = 0.077\text{ K/W}$

Free Wheeling Diode (typ.)  
 $C_{th1} = 0.138\text{ J/K}; R_{th1} = 0.48\text{ K/W}$   
 $C_{th2} = 0.957\text{ J/K}; R_{th2} = 0.13\text{ K/W}$

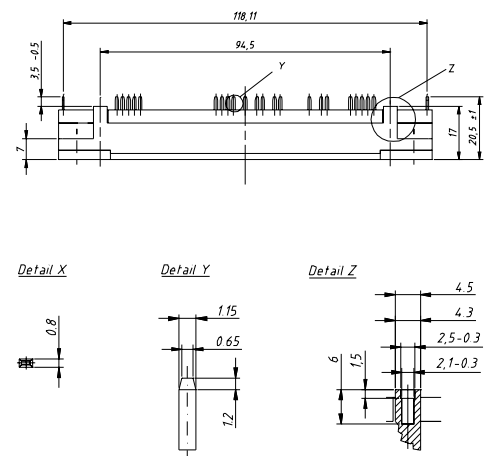
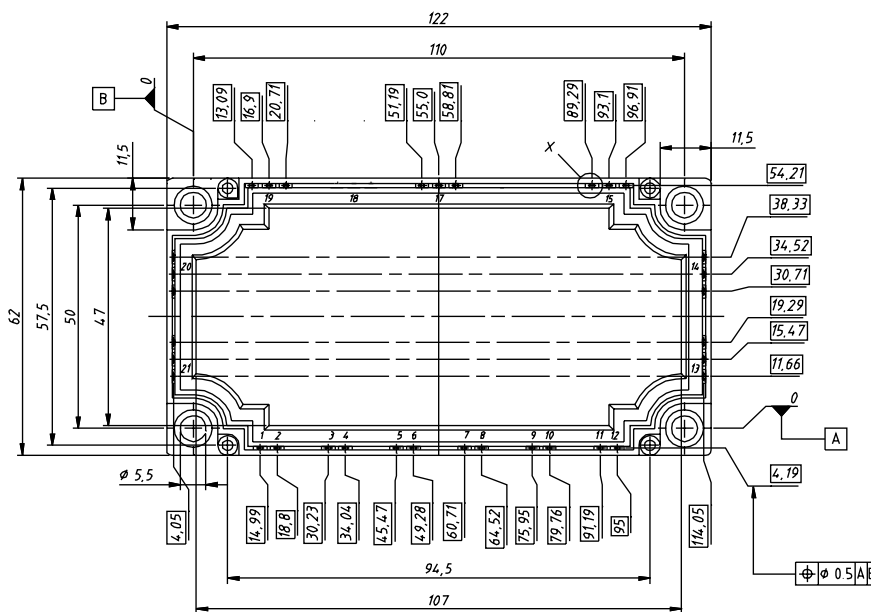

IXYS reserves the right to change limits, test conditions and dimensions.

© 2003 IXYS All rights reserved