



MX23C1611

5 Volt 16-Mbit (2M x 8 / 1M x 16) Mask ROM with Page Mode

FEATURES

- Bit organization
 - 2M x 8 (byte mode)
 - 1M x 16 (word mode)
- Fast access time
 - Random access: 100ns (max.)
 - Page access: 30ns (max.)
- Page Size
 - 8 double words per page
- Current
 - Operating: 60mA
 - Standby: 50uA
- Supply voltage
 - 5V±10%
- Package
 - 44 pin SOP (500mil)
 - 42 pin PDIP (600mil)
 - 48 pin TSOP (20mm x 12mm)

PIN CONFIGURATION

44 SOP

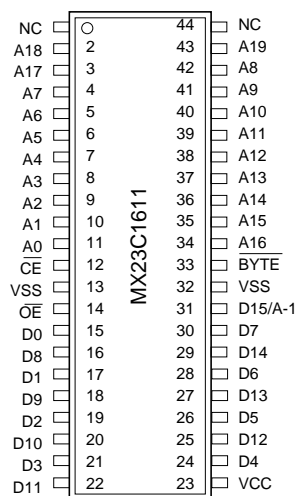

42 PDIP

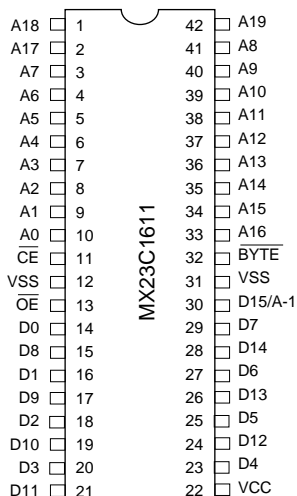

ORDER INFORMATION

Part No.	Access Page Access Package		
	Time	Time	
MX23C1611MC-10	100ns	30ns	44 pin SOP
MX23C1611MC-12	120ns	50ns	44 pin SOP
MX23C1611PC-10	100ns	30ns	42 pin PDIP
MX23C1611PC-12	120ns	50ns	42 pin PDIP
MX23C1611TC-10	100ns	30ns	48 pin TSOP
MX23C1611TC-12	120ns	50ns	48 pin TSOP

PIN DESCRIPTION

Symbol	Pin Function
A0~A19	Address Inputs
D0~D14	Data Outputs
D15/A-1	D15 (Word Mode)/ LSB Address (Byte Mode)
CE	Chip Enable Input
OE	Output Enable Input
Byte	Word/ Byte Mode Selection
VCC	Power Supply Pin
VSS	Ground Pin
NC	No Connection

MODE SELECTION

CE	OE	Byte	D31/A-1	D0~D15	D16~D31	Mode	Power
H	X	X	X	High Z	High Z	-	Stand-by
L	H	X	X	High Z	High Z	-	Active
L	L	H	Output	D0~D7	D8~D15	Word	Active
L	L	L	Input	D0~D7	High Z	Byte	Active



MX23C1611

48 TSOP (Normal Type)

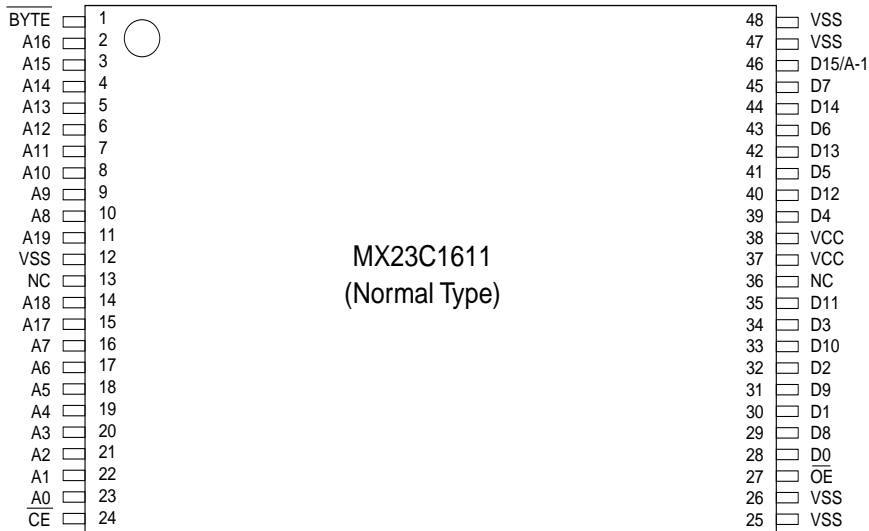

BLOCK DIAGRAM

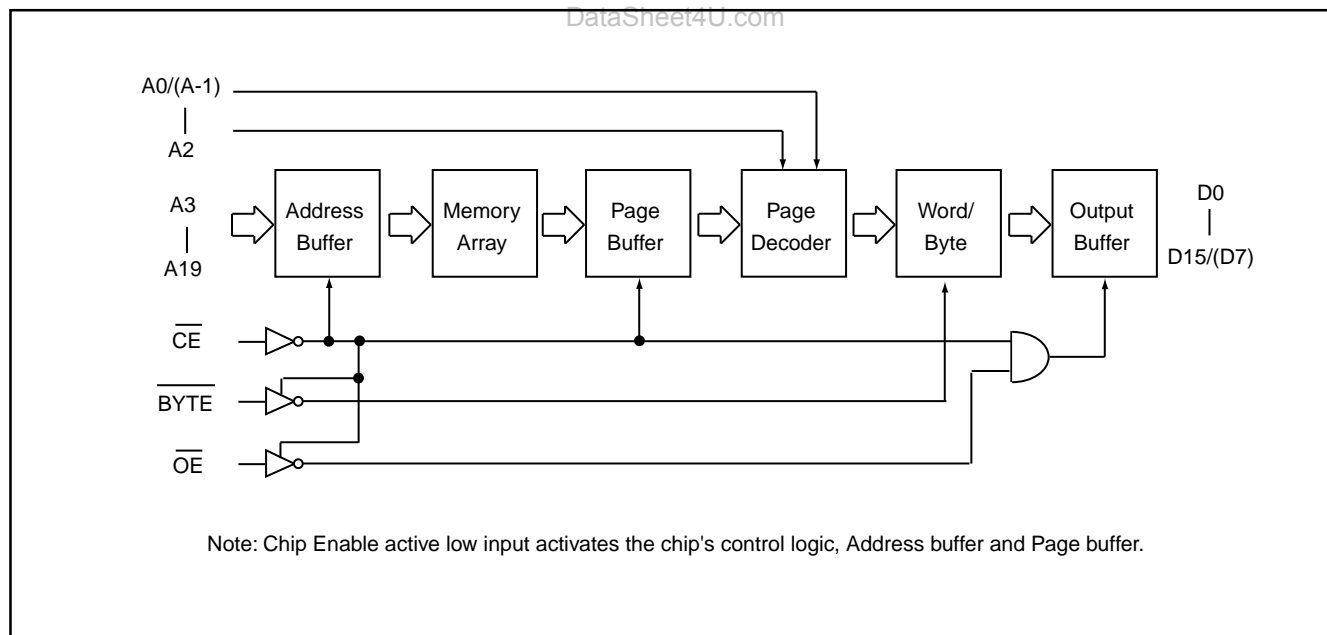



ABSOLUTE MAXIMUM RATINGS

Item	Symbol	Ratings
Voltage on any Pin Relative to VSS	VIN	-1.3V to VCC+2.0V (Note)
Ambient Operating Temperature	Topr	-40°C to 85°C
Storage Temperature	Tstg	-65°C to 125°C

Note: Minimum DC voltage on input or I/O pins is -0.5V. During voltage transitions, inputs may undershoot VSS to -1.3V for periods of up to 20ns. Maximum DC voltage on input or I/O pins is VCC+0.5V. During voltage transitions, input may overshoot VCC to VCC+2.0V for periods of up to 20ns.

DC CHARACTERISTICS (Ta = 0°C ~ 70°C, VCC = 5V±10%)

Item	Symbol	MIN.	MAX.	Conditions
Output High Voltage	VOH	2.4V	-	IOH = -1.0mA
Output Low Voltage	VOL	-	0.4V	IOL = 2.1mA
Input High Voltage	VIH	2.2V	VCC+0.3V	
Input Low Voltage	VIL	-0.3V	0.2 x VCC	
Input Leakage Current	ILI		5uA	0V, VCC
Output Leakage Current	ILO	-	5uA	0V, VCC
Operating Current	ICC1	-	60mA	tRC = 100ns, all output open
Standby Current (TTL)	ISTB1	-	1mA	$\overline{CE} = VIH$
Standby Current (cmos)	ISTB2	-	50uA	$\overline{CE} > VCC - 0.2V$
Input Capacitance	CIN	-	10pF	Ta = 25°C, f = 1MHZ
Output Capacitance	COUT	-	10pF	Ta = 25°C, f = 1MHZ

AC CHARACTERISTICS (Ta = 0°C ~ 70°C, VCC = 5V±10%)

Item	Symbol	23C1611-10		23C1611-12	
		MIN.	MAX.	MIN.	MAX.
Read Cycle Time	tRC	100ns	-	120ns	-
Address Access Time	tAA	-	100ns	-	120ns
Chip Enable Access Time	tCE	-	100ns	-	120ns
Page Mode Access Time	tPA	-	30ns	-	50ns
Output Enable Time	tOE	-	30ns	-	50ns
Output Hold After Address	tOH	0ns	-	0ns	-
Output High Z Delay	tHZ	-	20ns	-	20ns

Note: Output high-impedance delay (tHZ) is measured from \overline{OE} or \overline{CE} going high, and this parameter guaranteed by design over the full voltage and temperature operating range - not tested.



MX23C1611

AC Test Conditions

Input Pulse Levels	0.4V~ 2.4V
Input Rise and Fall Times	10ns
Input Timing Level	1.5V
Output Timing Level	0.8V and 2.0V
Output Load	See Figure

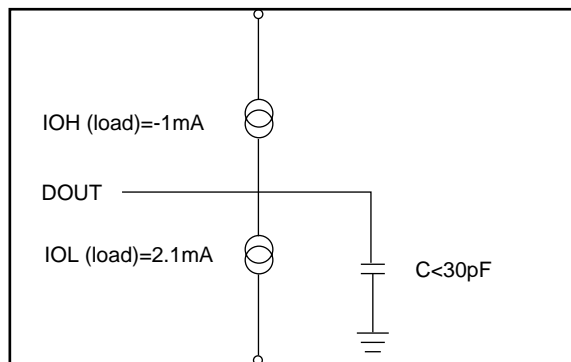

Note:

No output loading is present in tester load board.

Active loading is used and under software programming control.

Output loading capacitance includes load board's and all stray capacitance.

TIMING DIAGRAM

RANDOM READ

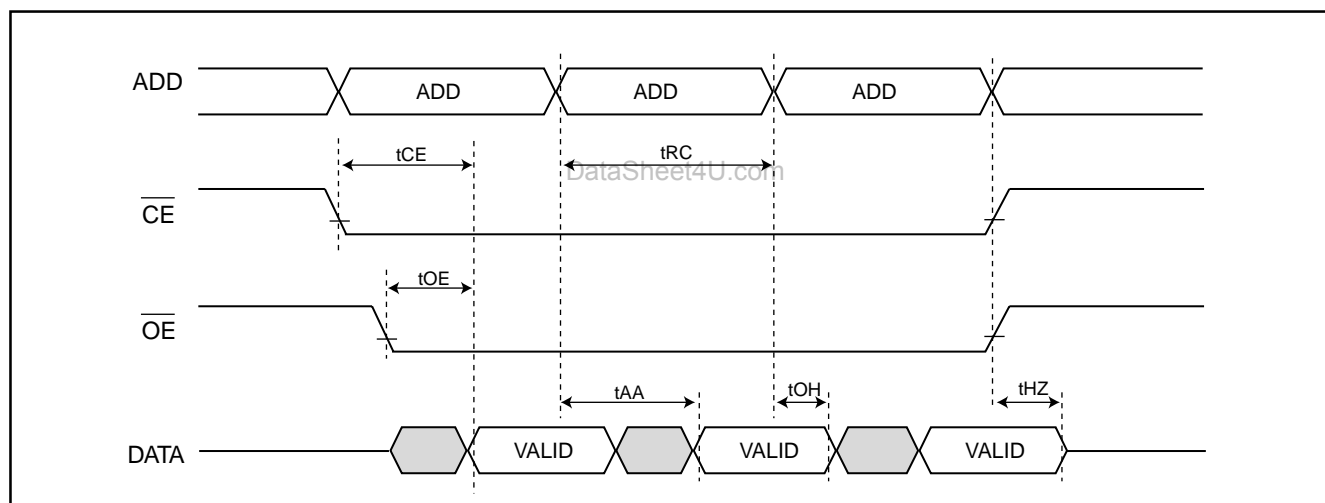

PAGE READ

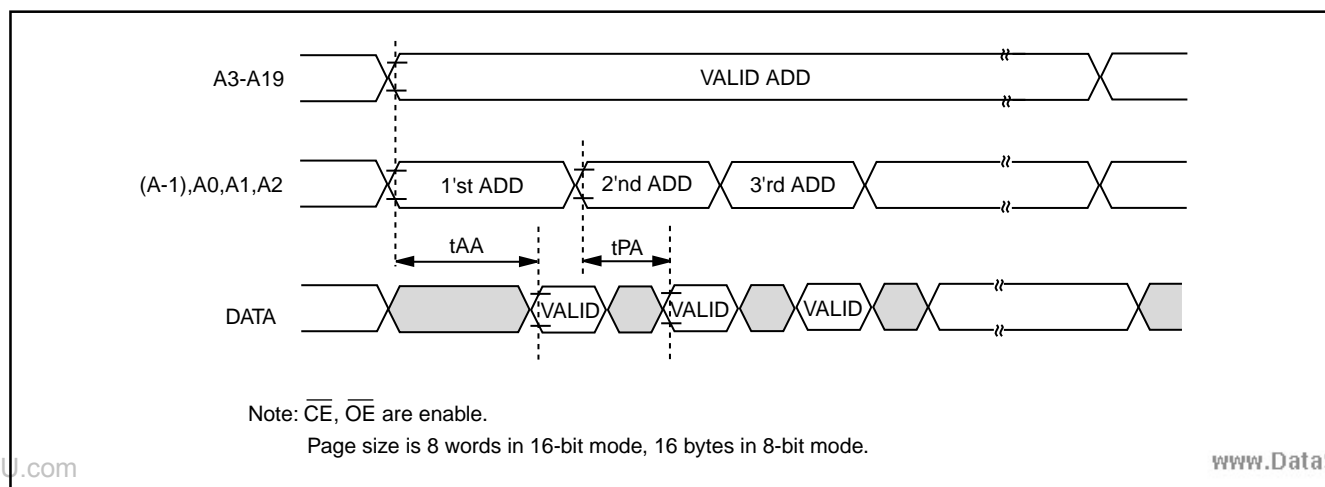



MX23C1611

PACKAGE INFORMATION

Title: Package Outline for PDIP 42L (600MIL)

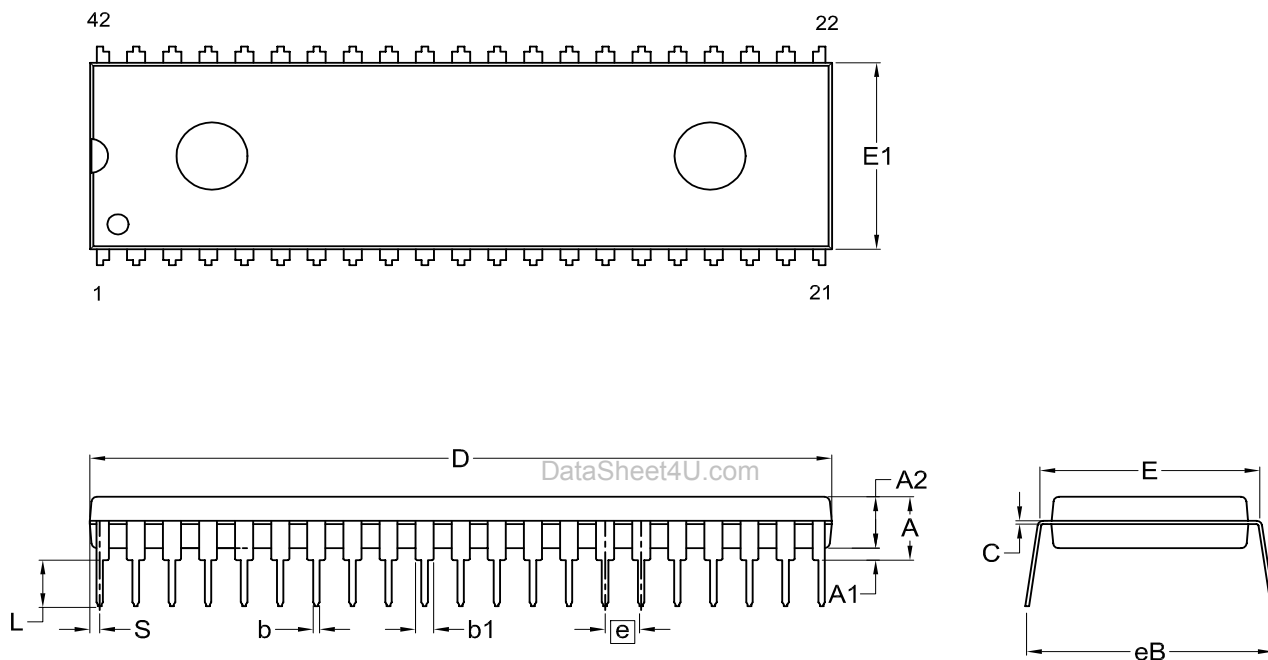

Dimensions (inch dimensions are derived from the original mm dimensions)

SYMBOL		A	A1	A2	b	b1	C	D	E	E1	e	eB	L	S
UNIT														
mm	Min.	---	0.25	3.73	0.38	1.14	0.20	51.31	15.11	13.84		15.75	2.92	0.38
	Nom.	---	---	3.94	0.46	1.27	0.25	51.94	15.24	13.97	2.54	16.51	3.30	0.64
	Max.	4.90	0.76	4.14	0.53	1.40	0.30	52.57	15.37	14.10		17.27	3.68	0.89
Inch	Min.	—	0.010	0.147	0.015	0.045	0.008	2.020	0.595	0.545		0.620	0.115	0.015
	Nom.	—	—	0.155	0.018	0.050	0.010	2.045	0.600	0.550	0.100	0.650	0.130	0.025
	Max.	0.193	0.030	0.163	0.021	0.055	0.012	2.070	0.605	0.555		0.680	0.145	0.035

DWG.NO.	REVISION	REFERENCE			ISSUE DATE
		JEDEC	EIAJ		
6110-0202.5	7				01-20-'03



MX23C1611

Title: Package Outline for SOP 44L (500MIL)

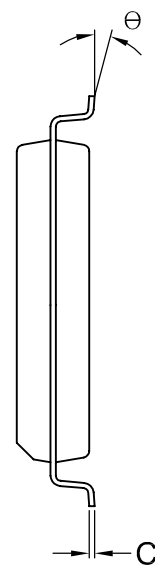
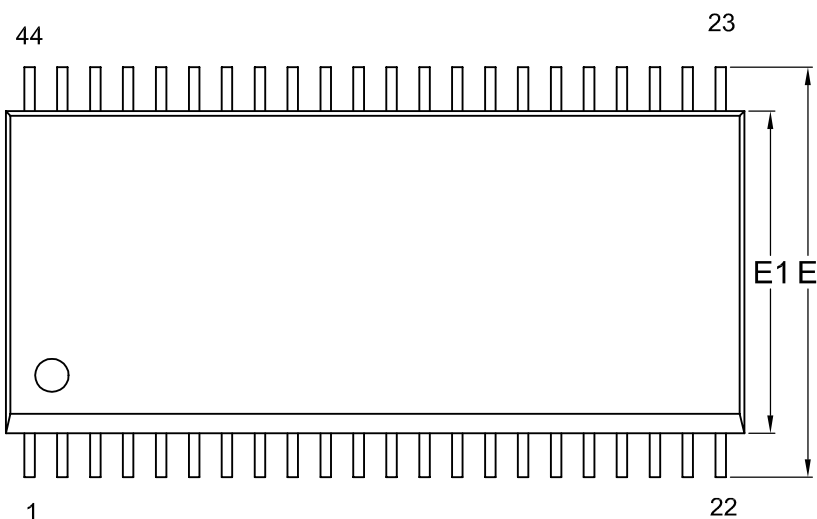

DataSheet4U.com

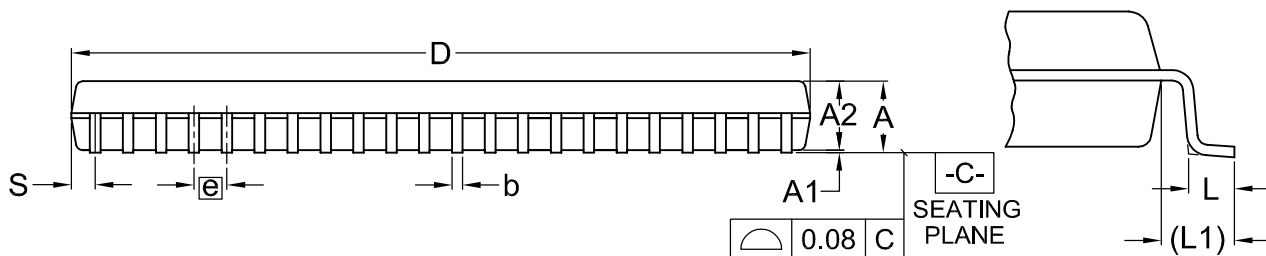

Dimensions (inch dimensions are derived from the original mm dimensions)

SYMBOL		A	A1	A2	b	C	D	E	E1	e	L	L1	S	θ
UNIT														
mm	Min.	---	0.10	2.59	0.36	0.15	28.37	15.83	12.47		0.56	1.51	0.78	0
	Nom.	---	0.15	2.69	0.41	0.20	28.50	16.03	12.60	1.27	0.76	1.71	0.91	5
	Max.	3.00	0.20	2.80	0.51	0.25	28.63	16.23	12.73		0.96	1.91	1.04	10
Inch	Min.	---	0.004	0.102	0.014	0.006	1.117	0.623	0.491		0.022	0.059	0.031	0
	Nom.	---	0.006	0.106	0.016	0.008	1.122	0.631	0.496	0.050	0.030	0.067	0.036	5
	Max.	0.118	0.008	0.110	0.020	0.010	1.127	0.639	0.501		0.038	0.075	0.041	10

DWG.NO.	REVISION	REFERENCE			ISSUE DATE
		JEDEC	EIAJ		
6110-1405	5	MO-175			09-24-02



MX23C1611

Title: Package Outline for TSOP(I) 48L (12X20mm)NORMAL FORM

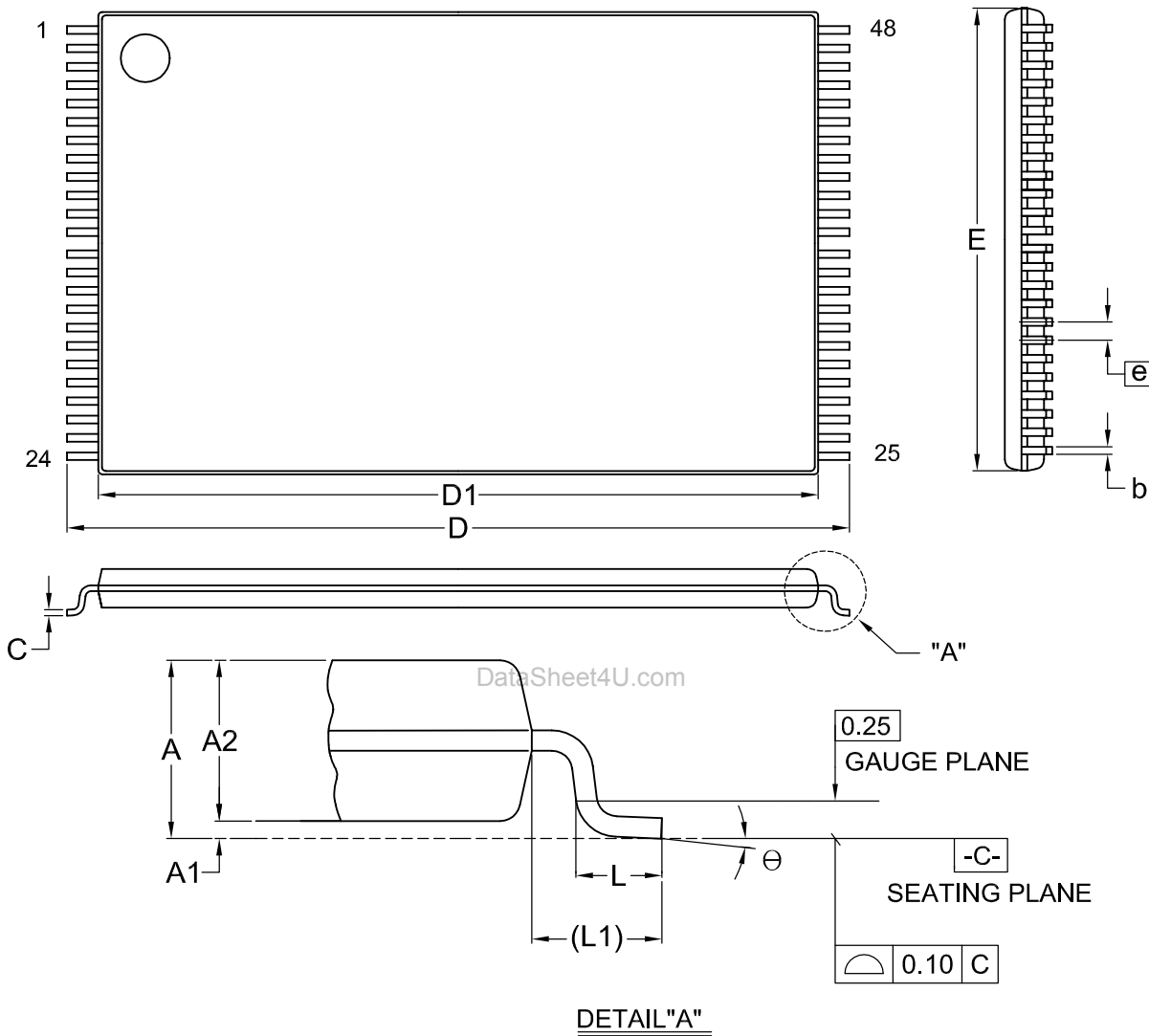

DETAIL "A"

Dimensions (inch dimensions are derived from the original mm dimensions)

SYMBOL		A	A1	A2	b	C	D	D1	E	e	L	L1	θ
UNIT													
mm	Min.	---	0.05	0.95	0.17	0.10	19.80	18.30	11.90		0.50	0.70	0
	Nom.	---	0.10	1.00	0.20	0.13	20.00	18.40	12.00	0.50	0.60	0.80	5
	Max.	1.20	0.15	1.05	0.27	0.21	20.20	18.50	12.10		0.70	0.90	8
Inch	Min.	---	0.002	0.037	0.007	0.004	0.780	0.720	0.469		0.020	0.028	0
	Nom.	---	0.004	0.039	0.008	0.005	0.787	0.724	0.472	0.020	0.024	0.031	5
	Max.	0.047	0.006	0.041	0.011	0.008	0.795	0.728	0.476		0.028	0.035	8

DWG.NO.	REVISION	REFERENCE			ISSUE DATE
		JEDEC	EIAJ		
6110-1607	6	MO-142			09-24-'02

**Revision History**

Revision	Description	Page	Date
1.8	tACE--->1000ns changes to tACE--->100ns	P3	JUL/20/1998
1.9	AC Characteristics: tOH 10ns --> 0ns	P3	FEB/01/1999
2.0	Typing error correction	P1	JAN/18/2000
2.1	Modify Package Information	P5~7	JUL/18/2001
2.2	1. Modify standby current:100ns-->50ns 2. Modify page access time:50ns(max.)-->30ns(max) 3. Modify package information	P1,3 P1,3 P5~7	NOV/21/2002
2.3	1. Modify 42-PDIP Package Information	P5	JUN/20/2003

et4U.com

DataSheet4U.com

DataShee



MX23C1611

et4U.com

DataSheet4U.com

MACRONIX INTERNATIONAL Co., LTD.

HEADQUARTERS:

TEL:+886-3-578-6688

FAX:+886-3-563-2888

EUROPE OFFICE:

TEL:+32-2-456-8020

FAX:+32-2-456-8021

JAPAN OFFICE:

TEL:+81-44-246-9100

FAX:+81-44-246-9105

SINGAPORE OFFICE:

TEL:+65-348-8385

FAX:+65-348-8096

TAIPEI OFFICE:

TEL:+886-2-2509-3300

FAX:+886-2-2509-2200

MACRONIX AMERICA, INC.

TEL:+1-408-453-8088

FAX:+1-408-453-8488

CHICAGO OFFICE:

TEL:+1-847-963-1900

FAX:+1-847-963-1909

DataSheet4U.com [http : //www.macronix.com](http://www.macronix.com)

www.DataSheet4U.com