



MACRONIX
INTERNATIONAL Co., LTD.

www.DataSheet4U.com

MX25L12855E

MX25L12855E
SECURED SERIAL FLASH SPECIFICATION
PRELIMINARY - PUBLIC

www.DataSheet4U.com

Contents

FEATURES	5
GENERAL DESCRIPTION	7
Table 1. Additional Features	7
PIN CONFIGURATION	8
PIN DESCRIPTION	8
BLOCK DIAGRAM	9
DATA PROTECTION	10
Table 2. Protected Area Sizes.....	11
Table 3. 4K-bit Secured OTP Definition	11
Memory Organization	12
Table 4. Memory Organization.....	12
DEVICE OPERATION	13
Figure 1-1. Serial Modes Supported (for Normal Serial mode)	13
Figure 1-2. Serial Modes Supported (for Double Transfer Rate serial read mode)	13
COMMAND DESCRIPTION	14
Table 5. Command Sets	14
(1) Write Enable (WREN)	16
(2) Write Disable (WRDI)	16
(3) Read Identification (RDID)	16
(4) Read Status Register (RDSR).....	17
(5) Write Status Register (WRSR)	18
Protection Modes	18
(6) Read Data Bytes (READ).....	19
(7) Read Data Bytes at Higher Speed (FAST_READ).....	19
(8) 2 x I/O Read Mode (2READ).....	19
(9) 4 x I/O Read Mode (4READ).....	20
(10) Fast Double Transfer Rate Read (FASTDTRD)	20
(11) 2 x I/O Double Transfer Rate Read Mode (2DTRD).....	20
(12) 4 x I/O Double Transfer Rate Read Mode (4DTRD).....	21
(13) Sector Erase (SE)	21
(14) Block Erase (BE)	22
(15) Block Erase (BE32K).....	22
(16) Chip Erase (CE)	22
(17) Page Program (PP)	23
(18) 4 x I/O Page Program (4PP)	23
Program/Erase Flow(1) with read array data	24
Program/Erase Flow(2) without read array data	25
(19) Continuously program mode (CP mode).....	26
(20) Parallel Mode (Highly recommended for production throughputs increasing).....	26
(21) Deep Power-down (DP)	27

(22) Release from Deep Power-down (RDP), Read Electronic Signature (RES).....	27
(23) Read Electronic Manufacturer ID & Device ID (REMS), (REMS2), (REMS4), (REMS4D)	27
Table 6. ID Definitions	28
(24) Enter Secured OTP (ENSO)	28
(25) Exit Secured OTP (EXSO)	28
(26) Read Security Register (RDSCUR).....	28
Security Register Definition	29
(27) Write Security Register (WRSCUR)	29
(28) GPIO Expander	30
(28-1) GPIO Function Enable (GPIOEN).....	30
(28-2) GPIO Function Disable (GPIODIS)	30
(28-3) GPIO Register Read/Write (GPIORW).....	30
(28-4) GPIO Register Reset (GPIORST).....	30
(29) Write Protection Selection (WPSEL)	32
WPSEL Flow.....	32
(30) Single Block Lock/Unlock Protection (SBLK/SBULK)	33
Block Lock Flow	33
Block Unlock Flow	34
(31) Read Block Lock Status (RDBLOCK)	35
(32) Gang Block Lock/Unlock (GBLK/GBULK)	35
(33) Clear SR Fail Flags (CLSR)	35
(34) Output Driving Configure (ODC)	35
(35) Enable SO to Output RY/BY# (ESRY)	36
(36) Disable SO to Output RY/BY# (DSRY)	36
(37) Enter CFI Mode (ENCFI).....	36
POWER-ON STATE	37
ELECTRICAL SPECIFICATIONS	38
ABSOLUTE MAXIMUM RATINGS	38
Figure 2. Maximum Negative Overshoot Waveform	38
CAPACITANCE TA = 25°C, f = 1.0 MHz	38
Figure 3. Maximum Positive Overshoot Waveform.....	38
Figure 4. INPUT TEST WAVEFORMS AND MEASUREMENT LEVEL	39
Figure 5. OUTPUT LOADING.....	39
Table 7. DC CHARACTERISTICS (Temperature = -40°C to 85°C for Industrial grade, VCC = 2.7V ~ 3.6V)	40
Table 8. AC CHARACTERISTICS (Temperature = -40°C to 85°C for Industrial grade, VCC = 2.7V ~ 3.6V)	41
Timing Analysis	43
Figure 6. Serial Input Timing.....	43
Figure 7. Output Timing	43
Figure 8. Serial Input Timing for Double Transfer Rate Mode	44
Figure 9. Serial Output Timing for Double Transfer Rate Mode.....	44
Figure 10. WP# Setup Timing and Hold Timing during WRSR when SRWD=1	45
Figure 11. Write Enable (WREN) Sequence (Command 06).....	45
Figure 12. Write Disable (WRDI) Sequence (Command 04).....	45

Figure 13. Read Identification (RDID) Sequence (Command 9F)	46
Figure 14. Read Identification (RDID) Sequence (Parallel)	46
Figure 15. Read Status Register (RDSR) Sequence (Command 05).....	47
Figure 16. Write Status Register (WRSR) Sequence (Command 01)	47
Figure 17. Read Data Bytes (READ) Sequence (Command 03).....	48
Figure 18. Read at Higher Speed (FAST_READ) Sequence (Command 0B)	48
Figure 19. Fast DT Read (FASTDTRD) Sequence (Command 0D)	49
Figure 20. 2 x I/O Read Mode Sequence (Command BB)	49
Figure 21. Fast Dual I/O DT Read (2DTRD) Sequence (Command BD)	50
Figure 22. 4 x I/O Read Mode Sequence (Command EB)	50
Figure 23. 4 x I/O Read Enhance Performance Mode Sequence (Command EB).....	51
Figure 24. Fast Quad I/O DT Read (4DTRD) Sequence (Command ED).....	52
Figure 25. Fast Quad I/O DT Read (4DTRD) Enhance Performance Sequence (Command ED)	53
Figure 26. Page Program (PP) Sequence (Command 02).....	54
Figure 27. 4 x I/O Page Program (4PP) Sequence (Command 38)	54
Figure 28. Continuously Program (CP) Mode Sequence with Hardware Detection (Command AD)	55
Figure 29. Sector Erase (SE) Sequence (Command 20)	55
Figure 30. Block Erase (BE) Sequence (Command D8)	55
Figure 31. Chip Erase (CE) Sequence (Command 60 or C7)	56
Figure 32. Deep Power-down (DP) Sequence (Command B9).....	56
Figure 33. Release from Deep Power-down and Read Electronic Signature (RES) Sequence (Command AB) ..	56
Figure 34. Release from Deep Power-down (RDP) Sequence (Command AB).....	57
Figure 35. Read Electronic Manufacturer & Device ID (REMS) Sequence (Command 90 or EF or DF or CF)	57
Figure 36. READ ARRAY SEQUENCE (Parallel)	58
Figure 37. AUTO PAGE PROGRAM TIMING SEQUENCE (Parallel)	59
Figure 38. Release from Deep Power-down and Read Electronic Signature (RES) Sequence (Parallel)	60
Figure 39. Read Electronic Manufacturer & Device ID (REMS) Sequence (Parallel).....	61
Figure 40. Write Protection Selection (WPSEL) Sequence (Command 68).....	62
Figure 41. Single Block Lock/Unlock Protection (SBLK/SBULK) Sequence (Command 36/39)	62
Figure 42. Read Block Protection Lock Status (RDBLOCK) Sequence (Command 3C).....	62
Figure 43. Gang Block Lock/Unlock (GBLK/GBULK) Sequence (Command 7E/98).....	63
Figure 44. Power-up Timing.....	63
Table 9. Power-Up Timing and VWI Threshold.....	63
INITIAL DELIVERY STATE	63
RECOMMENDED OPERATING CONDITIONS.....	64
ERASE AND PROGRAMMING PERFORMANCE	65
LATCH-UP CHARACTERISTICS	65
ORDERING INFORMATION	66
PART NAME DESCRIPTION.....	66
PACKAGE INFORMATION.....	67
REVISION HISTORY	69

128M-BIT [x 1/x 2/x 4] CMOS MXSMIO™ (SERIAL MULTI I/O) FLASH MEMORY**FEATURES****GENERAL**

- Serial Peripheral Interface compatible -- Mode 0 and Mode 3
- 134,217,728 x 1 bit structure or 67,108,864 x 2 bits (two I/O mode) structure or 33,554,432 x 4 bits (four I/O mode) structure
- 4096 Equal Sectors with 4K bytes each
 - Any Sector can be erased individually
- 512 Equal Blocks with 32K bytes each
 - Any Block can be erased individually
- 256 Equal Blocks with 64K bytes each
 - Any Block can be erased individually
- Power Supply Operation
 - 2.7 to 3.6 volt for read, erase, and program operations
- Latch-up protected to 100mA from -1V to Vcc +1V

PERFORMANCE

- High Performance
 - VCC = 2.7~3.6V
 - Normal read
 - 50MHz
 - Fast read (Normal Serial Mode)
 - 1 I/O: 104MHz with 8 dummy cycles
 - 2 I/O: 70MHz with 4 dummy cycles
 - 4 I/O: 70MHz with 6 dummy cycles
 - Fast read (Double Transfer Rate Mode)
 - 1 I/O: 50MHz with 6 dummy cycles
 - 2 I/O: 50MHz with 6 dummy cycles
 - 4 I/O: 50MHz with 8 dummy cycles
 - Fast program time: 1.4ms(typ.) and 5ms(max.)/page (256-byte per page)
 - Byte program time: 9us (typical)
 - Continuously Program mode (automatically increase address under word program mode)
 - Fast erase time: 90ms (typ.)/sector (4K-byte per sector) ; 0.7s(typ.) /block (64K-byte per block); 80s(typ.) /chip
- Low Power Consumption
 - Low active read current: 45mA(max.) at 104MHz, 40mA(max.) at 66MHz and 30mA(max.) at 33MHz
 - Low active programming current: 25mA (max.)
 - Low active erase current: 25mA (max.)
 - Low standby current: 100uA (max.)
 - Deep power down current: 40uA (max.)
- Typical 100,000 erase/program cycles

SOFTWARE FEATURES

- Input Data Format
 - 1-byte Command code
- Advanced Security Features

- Flexible block or individual block protect selection
- Individual block (or sector) permanent lock
- The BP0-BP3 status bits define the size of the area to be software protection against program and erase instructions
- Additional 4K bits secured OTP for unique identifier
- Auto Erase and Auto Program Algorithms
 - Automatically erases and verifies data at selected sector
 - Automatically programs and verifies data at selected page by an internal algorithm that automatically times the program pulse width (Any page to be programmed should have page in the erased state first.)
- Status Register Feature
- Electronic Identification
 - JEDEC 1-byte Manufacturer ID and 2-byte Device ID
 - RES command for 1-byte Device ID
 - Both REMS,REMS2, REMS4 and REMS4D commands for 1-byte Manufacturer ID and 1-byte Device ID
- Support Common Flash Interface (CFI) (TBD)

HARDWARE FEATURES

- SCLK Input
 - Serial clock input
- SI/SIO0
 - Serial Data Input or Serial Data Input/Output for 2 x I/O mode and 4 x I/O mode
- SO/SIO1/PO7
 - Serial Data Output or Serial Data Input/Output for 2 x I/O mode and 4 x I/O mode or Parallel Mode Data
- WP#/SIO2
 - Hardware write protection or serial data Input/Output for 4 x I/O mode
- NC/SIO3
 - NC pin or serial data Input/Output for 4 x I/O mode
- P00~P06
 - For parallel mode data
- PACKAGE
 - 16-pin SOP (300mil)
 - 24-ball TFBGA (10x13 mm)
 - **All Pb-free devices are RoHS Compliant**

Please contact Macronix sales for specific information regarding this Advanced Security Features

GENERAL DESCRIPTION

The MX25L12855E is 134,217,728 bits serial Flash memory, which is configured as 16,777,216 x 8 internally. When it is in two or four I/O mode, the structure becomes 67,108,864 bits x 2 or 33,554,432 bits x 4. The MX25L12855E features a serial peripheral interface and software protocol allowing operation on a simple 3-wire bus. The three bus signals are a clock input (SCLK), a serial data input (SI), and a serial data output (SO). Serial access to the device is enabled by CS# input.

The MX25L12855E provides high performance read mode, which may latch address and data on both rising and falling edge of clock. By using this high performance read mode, the data throughput may be doubling. Moreover, the performance may reach direct code execution, the RAM size of the system may be reduced and further saving system cost.

The MX25L12855E provides sequential read operation on whole chip and multi-I/O features.

When it is in dual I/O mode, the SI pin and SO pin become SIO0 pin and SIO1 pin for address/dummy bits input and data output. When it is in quad I/O mode, the SI pin, SO pin, WP# pin and NC pin become SIO0 pin, SIO1 pin, SIO2 pin and SIO3 pin for address/dummy bits input and data Input/Output.

After program/erase command is issued, auto program/ erase algorithms which program/ erase and verify the specified page or sector/block locations will be executed. Program command is executed on byte basis, or page (256 bytes) basis, or word basis for Continuously Program mode, and erase command is executes on sector (4K-byte), block (32K-byte/64K-byte), or whole chip basis.

To provide user with ease of interface, a status register is included to indicate the status of the chip. The status read command can be issued to detect completion status of a program or erase operation via WIP bit.

Advanced security features enhance the protection and security functions, please see Security Features section for more details.

When the device is not in operation and CS# is high, it is put in standby mode and draws less than 100uA DC current.

The MX25L12855E utilizes MXIC's proprietary memory cell, which reliably stores memory contents even after 100,000 program and erase cycles.

Table 1. Additional Features

Additional Features Part Name	Protection and Security		Read Performance						
	Permanent Lock and read lock	Individual block (or sector) protection	1 I/O Read (104 MHz)	2 I/O Read (70 MHz)	4 I/O Read (70 MHz)	1 I/O DT Read (50 MHz)	2 I/O DT Read (50 MHz)	4 I/O DT Read (50 MHz)	8 I/O Parallel Mode (6 MHz)
MX25L12855E	V	V	V	V	V	V	V	V	V

Additional Features Part Name	Identifier					
	RES (command: AB hex)	REMS (command: 90 hex)	REMS2 (command: EF hex)	REMS4 (command: DF hex)	REMS4D (command: CF hex)	RDID (command: 9F hex)
MX25L12855E	88 (hex)	C2 88 (hex) (if ADD=0)	C2 88 (hex) (if ADD=0)	C2 88 (hex) (if ADD=0)	C2 88 (hex) (if ADD=0)	C2 26 18 (hex)

PIN CONFIGURATION

Please contact Macronix sales for specific information regarding 16-pin SOP (300mil) and 24-ball TFBGA (10x13mm) package pin configuration.

PIN DESCRIPTION

SYMBOL	DESCRIPTION
CS#	Chip Select
SI/SIO0	Serial Data Input (for 1 x I/O)/ Serial Data Input & Output (for 2xI/O or 4xI/O mode)
SO/SIO1/ PO7	Serial Data Output (for 1 x I/O)/ Serial Data Input & Output (for 2xI/O or 4xI/O mode) / Parallel Data Output/Input
SCLK	Clock Input
WP#/SIO2	Write protection: connect to GND or Serial Data Input & Output (for 4xI/O mode)
NC/SIO3	NC pin (Not connect) or Serial Data Input & Output (for 4xI/O mode)
VCC	+ 3.3V Power Supply
GND	Ground
GPIO0/PO0 ~ GPIO6/ PO6	General Purpose Input & Output/ Parallel data output/input (PO0~PO6 can be connected to NC in serial mode)
NC	No Connection

BLOCK DIAGRAM

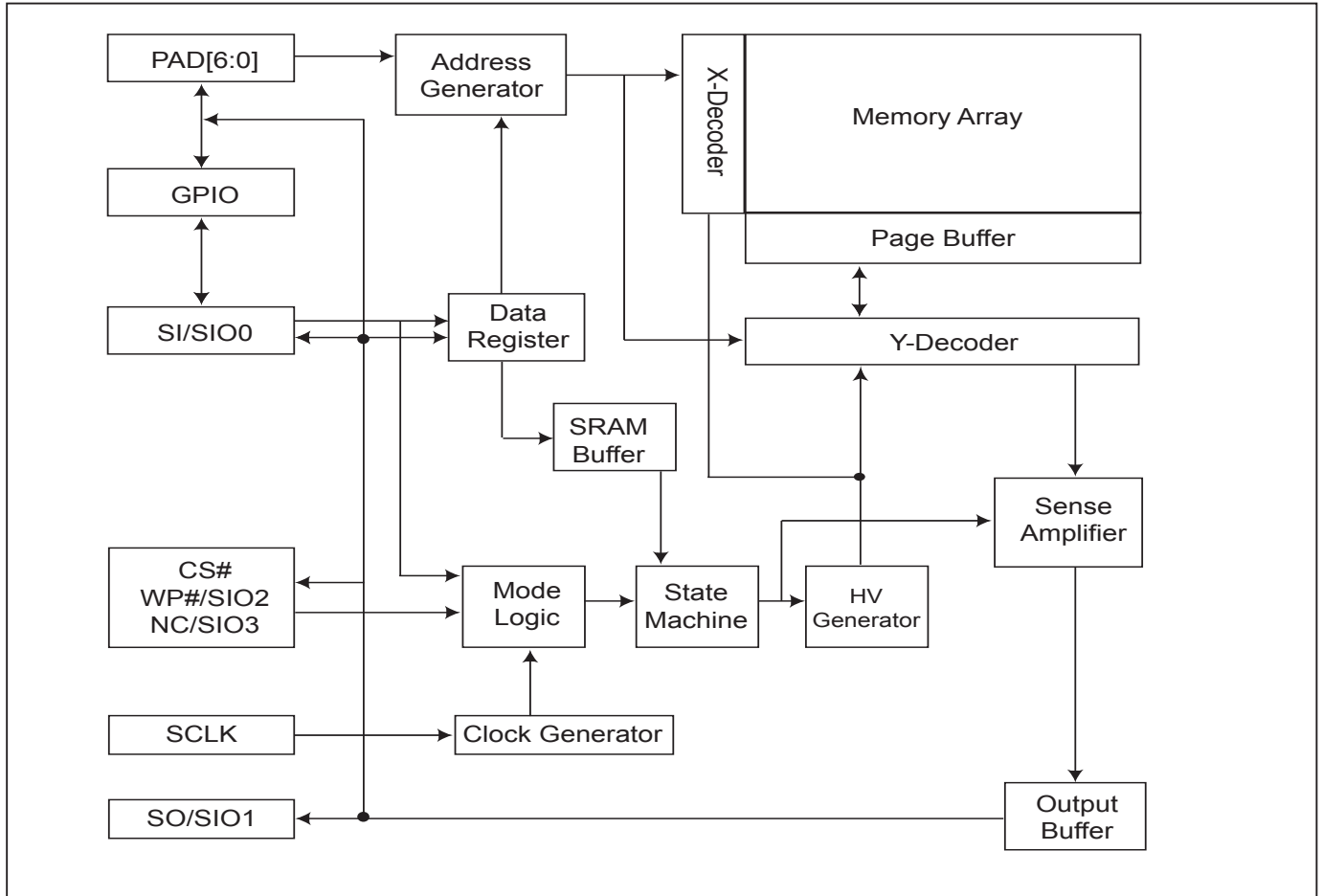

DATA PROTECTION

The MX25L12855E is designed to offer protection against accidental erasure or programming caused by spurious system level signals that may exist during power transition. During power up the device automatically resets the state machine in the standby mode. In addition, with its control register architecture, alteration of the memory contents only occurs after successful completion of specific command sequences. The device also incorporates several features to prevent inadvertent write cycles resulting from VCC power-up and power-down transition or system noise.

- Valid command length checking: The command length will be checked whether it is at byte base and completed on byte boundary.
- Write Enable (WREN) command: WREN command is required to set the Write Enable Latch bit (WEL) before other command to change data. The WEL bit will return to reset stage under following situation:
 - Power-up
 - Write Disable (WRDI) command completion
 - Write Status Register (WRSR) command completion
 - Page Program (PP, 4PP) command completion
 - Continuously Program mode (CP) instruction completion
 - Sector Erase (SE) command completion
 - Block Erase (BE, BE32K) command completion
 - Chip Erase (CE) command completion
 - Single Block Lock/Unlock (SBLK/SBULK) instruction completion
 - Gang Block Lock/Unlock (GBLK/GBULK) instruction completion
 - Permanent Lock (PLOCK) instruction completion
 - Write Read Lock Register (WRLCR) command completion
- Deep Power Down Mode: By entering deep power down mode, the flash device also is under protected from writing all commands except Release from Deep Power Down mode command (RDP) and Read Electronic Signature command (RES).
- Advanced Security Features: there are some protection and security features which protect content from inadvertent write and hostile access.

I. Block lock protection

- The Software Protected Mode (SPM) uses (BP3, BP2, BP1, BP0) bits to allow part of memory to be protected as read only. The protected area definition is shown as table of "Protected Area Sizes", the protected areas are more flexible which may protect various area by setting value of BP0-BP3 bits. Please refer to table of "Protected Area Sizes".
- The Hardware Protected Mode (HPM) use WP#/SIO2 to protect the (BP3, BP2, BP1, BP0) bits and SRWD bit. If the system goes into four I/O mode, the feature of HPM will be disabled.
- MX25L12855E provide individual block (or sector) write protect & unprotect. User may enter the mode with WPSEL command and conduct individual block (or sector) write protect with SBLK instruction, or SBULK for individual block (or sector) unprotect. Under the mode, user may conduct whole chip (all blocks) protect with GBLK instruction and unlock the whole chip with GBULK instruction. For sector(s) or block(s) that is (are) permanently locked, SBULK & GBULK does not influence the state of the permanently locked sector(s)' or block(s)' status.

Table 2. Protected Area Sizes

Status bit				Protection Area
BP3	BP2	BP1	BP0	128Mb
1	1	1	1	All
1	1	1	0	All
1	1	0	1	All
1	1	0	0	All
1	0	1	1	All
1	0	1	0	All
1	0	0	1	All
1	0	0	0	All
0	1	1	1	Upper half (hundrend and twenty-eight blocks: 128 to 255)
0	1	1	0	Upper quarter (sixty-four blocks: 192 to 255)
0	1	0	1	Upper eighth (thirty-two blocks: 224 to 255)
0	1	0	0	Upper sixteenth (sixteen blocks: 240 to 255)
0	0	1	1	Upper 32nd (eight blocks: 248 to 255)
0	0	1	0	Upper 64th (four blocks: 252 to 255)
0	0	0	1	Upper 128th (two blocks: 254 and 255)
0	0	0	0	None

Note: The device is ready to accept a Chip Erase instruction if, and only if, all Block Protect (BP3, BP2, BP1, BP0) are 0.

II. Additional 4K-bit secured OTP for unique identifier: to provide 4K-bit One-Time Program area for setting device unique serial number - Which may be set by factory or system maker. Please refer to Table 3. 4K-bit Secured OTP Definition.

- Security register bit 0 indicates whether the chip is locked by factory or not.
- To program the 4K-bit secured OTP by entering 4K-bit secured OTP mode (with ENSO command), and going through normal program procedure, and then exiting 4K-bit secured OTP mode by writing EXSO command.
- Customer may lock-down the customer lockable secured OTP by writing WRSCUR(write security register) command to set customer lock-down bit1 as "1". Please refer to table of "Security Register Definition" for security register bit definition and table of "4K-bit Secured OTP Definition" for address range definition.
- Note: Once lock-down whatever by factory or customer, it cannot be changed any more. While in 4K-bit Secured OTP mode, array access is not allowed.

Table 3. 4K-bit Secured OTP Definition

Address range	Size	Standard Factory Lock	Customer Lock
xxx000~xxx00F	128-bit	ESN (electrical serial number)	Determined by customer
xxx010~xxxFFF	3968-bit	N/A	

Memory Organization

Table 4. Memory Organization

Block(64K-byte)	Block(32K-byte)	Sector	Address Range	
255	511	4095	FFF000h	FFFFFFh
		⋮		
		4088	FF8000h	FF8FFFh
	510	4087	FF7000h	FF7FFFh
		⋮		
		4080	FF0000h	FF0FFFh
254	509	4079	FEF000h	FEFFFFh
		⋮		
		4072	FE8000h	FE8FFFh
	508	4071	FE7000h	FE7FFFh
		⋮		
		4064	FE0000h	FE0FFFh
253	507	4063	FDF000h	FDFFFFh
		⋮		
		4056	FD8000h	FD8FFFh
	506	4055	FD7000h	FD7FFFh
		⋮		
		4048	FD0000h	FD0FFFh

individual block lock/unlock unit:64K-byte

individual 16 sectors lock/unlock unit:4K-byte

individual block lock/unlock unit:64K-byte

2	5	47	02F000h	02FFFFh
		⋮		
		40	028000h	028FFFh
	4	39	027000h	027FFFh
		⋮		
		32	020000h	020FFFh
1	3	31	01F000h	01FFFFh
		⋮		
		24	018000h	018FFFh
	2	23	017000h	017FFFh
		⋮		
		16	010000h	010FFFh
0	1	15	00F000h	00FFFFh
		⋮		
		8	008000h	008FFFh
	0	7	007000h	007FFFh
		⋮		
		0	000000h	000FFFh

individual block lock/unlock unit:64K-byte

individual 16 sectors lock/unlock unit:4K-byte

DEVICE OPERATION

1. Before a command is issued, status register should be checked to ensure device is ready for the intended operation.
2. When incorrect command is inputted to this LSI, this LSI becomes standby mode and keeps the standby mode until next CS# falling edge. In standby mode, SO pin of this LSI should be High-Z.
3. When correct command is inputted to this LSI, this LSI becomes active mode and keeps the active mode until next CS# rising edge.
4. For standard single data rate serial mode, input data is latched on the rising edge of Serial Clock(SCLK) and data shifts out on the falling edge of SCLK. The difference of Serial mode 0 and mode 3 is shown as Figure 1-1. For high performance (Double Transfer Rate Read serial mode), data is latched on both rising and falling edge of clock and data shifts out on both rising and falling edge of clock as Figure 1-2.
5. For the following instructions: RDID, RDSR, RDSCUR, READ, FAST_READ, 2READ, 4READ, FASTDTRD, 2DTRD, 4DTRD, RDBLOCK, PRLCR, RES, REMS, REMS2, REMS4 and REMS4D the shifted-in instruction sequence is followed by a data-out sequence. After any bit of data being shifted out, the CS# can be high. For the following instructions: WREN, WRDI, Parallel Mode WRSR, SE, BE, BE32K, CE, PP, CP, 4PP, RDP, DP, WPSEL, SBLK, SBULK, GBLK, GBULK, PLOCK, WRLCR, ENSO, EXSO, and WRSCUR, the CS# must go high exactly at the byte boundary; otherwise, the instruction will be rejected and not executed.
6. During the progress of Write Status Register, Program, Erase operation, to access the memory array is neglected and not affect the current operation of Write Status Register, Program, Erase.

Figure 1-1. Serial Modes Supported (for Normal Serial mode)

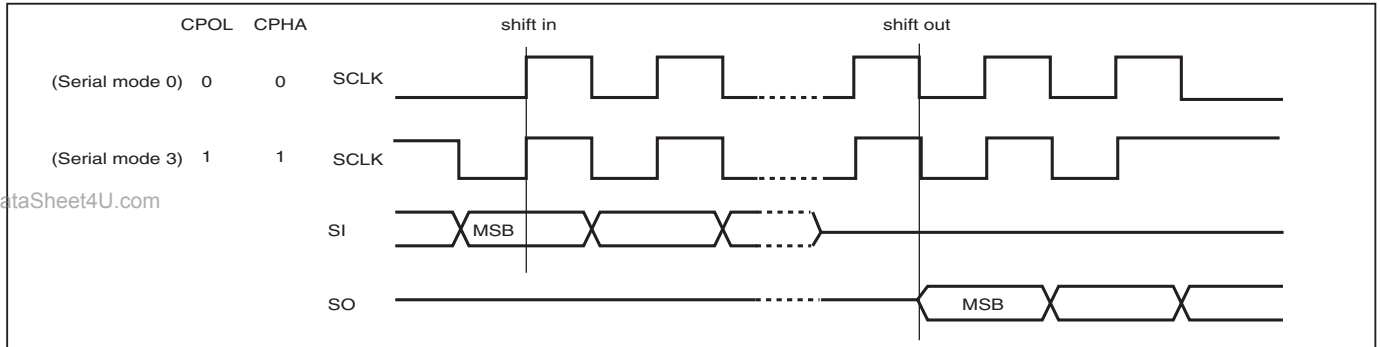

Note:

CPOL indicates clock polarity of Serial master, CPOL=1 for SCLK high while idle, CPOL=0 for SCLK low while not transmitting. CPHA indicates clock phase. The combination of CPOL bit and CPHA bit decides which Serial mode is supported.

Figure 1-2. Serial Modes Supported (for Double Transfer Rate serial read mode)

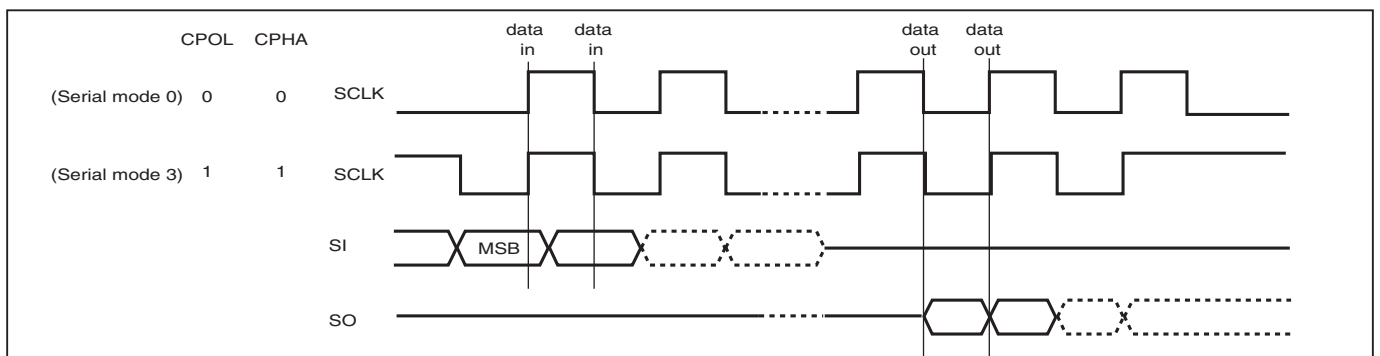

COMMAND DESCRIPTION

Table 5. Command Sets

COMMAND (byte)	WREN (write enable)	WRDI (write disable)	RDID (read identification)	RDSR (read status register)	WRSR (write status register)	FASTDTRD (fast DT read)	2DTRD (Dual I/O DT Read)	4DTRD (Quad I/O DT Read)
1st byte	06 (hex)	04 (hex)	9F (hex)	05 (hex)	01 (hex)	0D (hex)	BD (hex)	ED (hex)
2nd byte					Values	ADD1	ADD(2) & Dummy(2)	ADD(4) & Dummy(4)
3rd byte						ADD(1) & Dummy(1)	Dummy(2)	Dummy(4)
4th byte						Dummy(1)		
Action	sets the (WEL) write enable latch bit	resets the (WEL) write enable latch bit	outputs JEDEC ID: 1-byte Manufacturer ID & 2-byte Device ID	to read out the values of the status register	to write new values to the status register	n bytes read out (Double Transfer Rate) until CS# goes high	n bytes read out (Double Transfer Rate) by 2x I/O until CS# goes high	n bytes read out (Double Transfer Rate) by 4x I/O until CS# goes high

COMMAND (byte)	READ (read data)	FAST READ (fast read data)	2READ (2 x I/O read command) Note1	4READ (4 x I/O read command)	4PP (quad page program)	SE (sector erase)	BE (block erase 64KB)	BE 32K (block erase 32KB)
1st byte	03 (hex)	0B (hex)	BB (hex)	EB (hex)	38 (hex)	20 (hex)	D8 (hex)	52 (hex)
2nd byte	AD1 (A23-A16)	AD1	ADD(2)	ADD(4) & Dummy(4)	AD1	AD1	AD1	AD1
3rd byte	AD2 (A15-A8)	AD2	ADD(2) & Dummy(2)	Dummy(4)		AD2	AD2	AD2
4th byte	AD3 (A7-A0)	AD3				AD3	AD3	AD3
5th byte		Dummy						
Action	n bytes read out until CS# goes high	n bytes read out until CS# goes high	n bytes read out by 2 x I/O until CS# goes high	n bytes read out by 4 x I/O until CS# goes high	quad input to program the selected page	to erase the selected sector	to erase the selected 64KB block	to erase the selected 32KB block

COMMAND (byte)	CE (chip erase)	PP (Page program)	CP (Continuously program mode)	DP (Deep power down)	RDP (Release from deep power down)	RES (read electronic ID)	REMS (read electronic manufacturer & device ID)	REMS2 (read ID for 2x I/O mode)
1st byte	60 or C7 (hex)	02 (hex)	AD (hex)	B9 (hex)	AB (hex)	AB (hex)	90 (hex)	EF (hex)
2nd byte		AD1	AD1			x	x	x
3rd byte		AD2	AD2			x	x	x
4th byte		AD3	AD3			x	ADD (Note 2)	ADD (Note 2)
Action	to erase whole chip	to program the selected page	continuously program whole chip, the address is automatically increase	enters deep power down mode	release from deep power down mode	to read out 1-byte Device ID	output the Manufacturer ID & Device ID	output the Manufacturer ID & Device ID

COMMAND (byte)	REMS4 (read ID for 4x I/O mode)	REMS4D (read ID for 4x I/O DT mode)	ENSO (enter secured OTP)	EXSO (exit secured OTP)	RDSCUR (read security register)	WRSCUR (write security register)	ESRY (enable SO to output RY/BY#)	DSRY (disable SO to output RY/BY#)	ENCFI (enter CFI mode)
1st byte	DF (hex)	CF (hex)	B1 (hex)	C1 (hex)	2B (hex)	2F (hex)	70 (hex)	80 (hex)	A5 (hex)
2nd byte	x	x							x
3rd byte	x	x							x
4th byte	ADD (Note 2)	ADD (Note 2)							ADD (A7 is don't care)
5th byte									Dummy
Action	output the Manufacturer ID & device ID	output the Manufacturer ID & Device ID	to enter the 4K-bit Secured OTP mode	to exit the 4K-bit Secured OTP mode	to read value of security register	to set the lock-down bit as "1" (once lock-down, cannot be updated)	to enable SO to output RY/BY# during CP mode	to disable SO to output RY/BY# during CP mode	to enter CFI Query

COMMAND (byte)	ENPLM (Enter Parallel Mode)	EXPLM (EXIT Parallel Mode)	CLSR (Clear SR Fail Flags)	HPM (High Performance Enable Mode)	ODC (Output driving Configure)	GPIOEN (GPIO function enable)	GPIODIS (GPIO function Disable)	GPIORW (GPIO register read/write)	GPIORST (GPIO register reset)
1st byte	55 (hex)	45 (hex)	30 (hex)	A3 (hex)	6D (hex)	1A (hex)	18 (hex)	1C (hex)	1E (hex)
2nd byte				Dummy	Values			Values	
3rd byte				Dummy				Values	
4th byte				Dummy					
Action	8xI/O parallel programming mode	to exit 8xI/O parallel programming mode	clear security register bit 6 and bit 5	Quad I/O high Performance mode	change the option value of output driving	enable the function of GPIO mode	disable the function of GPIO mode	change/read the value of GPIO registers	reset all the GPIO registers

www.DataSheet4U.com

COMMAND (byte)	WPSEL (write protection selection)	SBLK (single block lock) *Note 4	SBULK (single block unlock)	RDBLOCK (block protect read)	GBLK (gang block lock)	GBULK (gang block unlock)
1st byte	68 (hex)	36 (hex)	39 (hex)	3C (hex)	7E (hex)	98 (hex)
2nd byte		AD1	AD1	AD1		
3rd byte		AD2	AD2	AD2		
4th byte		AD3	AD3	AD3		
Action	to enter and enable individual block protect mode	individual block (64K-byte) or sector (4K-byte) write protect	individual block (64K-byte) or sector (4K-byte) unprotect	read individual block or sector write protect status	whole chip write protect	whole chip unprotect

Note 1: The count base is 4-bit for ADD(2) and Dummy(2) because of 2 x I/O. And the MSB is on SI/SIO1 which is different from 1 x I/O condition.

Note 2: ADD=00h will output the Manufacturer ID first and ADD=01h will output Device ID first.

Note 3: It is not recommended to adopt any other code not in the command definition table, which will potentially enter the hidden mode.

Note 4. In individual block write protection mode, all blocks/sectors is locked as default.

(1) Write Enable (WREN)

The Write Enable (WREN) instruction is for setting Write Enable Latch (WEL) bit. For those instructions like PP, 4PP, CP, SE, BE, BE32K, CE, WRSR, WRLCR, SBLK, SBULK, GBLK, GBULK, and PLOCK which are intended to change the device content, should be set every time after the WREN instruction setting the WEL bit.

The sequence of issuing WREN instruction is: CS# goes low→ sending WREN instruction code→ CS# goes high. (see Figure 11)

(2) Write Disable (WRDI)

The Write Disable (WRDI) instruction is for resetting Write Enable Latch (WEL) bit.

The sequence of issuing WRDI instruction is: CS# goes low→ sending WRDI instruction code→ CS# goes high. (see Figure 12)

The WEL bit is reset by following situations:

- Power-up
- Write Disable (WRDI) instruction completion
- Write Status Register (WRSR) instruction completion
- Write Read Lock Register (WRLCR) instruction completion
- Page Program (PP, 4PP) instruction completion
- Sector Erase (SE) instruction completion
- Block Erase (BE, BE32K) instruction completion
- Chip Erase (CE) instruction completion
- Continuously Program mode (CP) instruction completion
- Single Block Lock/Unlock (SBLK/SBULK) instruction completion
- Gang Block Lock/Unlock (GBLK/GBULK) instruction completion
- Permanent Lock (PLOCK) instruction completion
- Write Read Lock Register (WRLCR) command completion

www.DataSheet4U.com

(3) Read Identification (RDID)

The RDID instruction is for reading the Manufacturer ID of 1-byte and followed by Device ID of 2-byte. The MXIC Manufacturer ID is C2(hex), the memory type ID is 26(hex) as the first-byte Device ID, and the individual Device ID of second-byte ID are listed as table of "ID Definitions". (see Table 8 in page 31)

The sequence of issuing RDID instruction is: CS# goes low-> sending RDID instruction code -> 24-bits ID data out on SO -> to end RDID operation can use CS# to high at any time during data out. (see Figure 13 and Figure 14 for parallel mode)

While Program/Erase operation is in progress, it will not decode the RDID instruction, so there's no effect on the cycle of program/erase operation which is currently in progress. When CS# goes high, the device is at standby stage.

(4) Read Status Register (RDSR)

The RDSR instruction is for reading Status Register. The Read Status Register can be read at any time (even in program/erase/write status register condition) and continuously. It is recommended to check the Write in Progress (WIP) bit before sending a new instruction when a program, erase, or write status register operation is in progress.

The sequence of issuing RDSR instruction is: CS# goes low-> sending RDSR instruction code-> Status Register data out on SO (see Figure 15).

The definition of the status register bits is as below:

WIP bit. The Write in Progress (WIP) bit, a volatile bit, indicates whether the device is busy in program/erase/write status register progress. When WIP bit sets to 1, which means the device is busy in program/erase/write status register progress. When WIP bit sets to 0, which means the device is not in progress of program/erase/write status register cycle.

WEL bit. The Write Enable Latch (WEL) bit, a volatile bit, indicates whether the device is set to internal write enable latch. When WEL bit sets to "1", which means the internal write enable latch is set, the device can accept program/erase/write status register instruction. When WEL bit sets to 0, which means no internal write enable latch; the device will not accept program/erase/write status register instruction. The program/erase command will be ignored and will reset WEL bit if it is applied to a protected memory area.

BP3, BP2, BP1, BP0 bits. The Block Protect (BP3, BP2, BP1, BP0) bits, non-volatile bits, indicate the protected area(as defined in Table 2) of the device to against the program/erase instruction without hardware protection mode being set. To write the Block Protect (BP3, BP2, BP1, BP0) bits requires the Write Status Register (WRSR) instruction to be executed. Those bits define the protected area of the memory to against Page Program (PP), Sector Erase (SE), Block Erase (BE) and Chip Erase(CE) instructions (only if all Block Protect bits set to 0, the CE instruction can be executed).

QE bit. The Quad Enable (QE) bit, non-volatile bit, while it is "0" (factory default), it performs non-Quad and WP# is enable. While QE is "1", it performs Quad I/O mode and WP# is disabled. In the other word, if the system goes into four I/O mode (QE=1), the feature of HPM will be disabled.

SRWD bit. The Status Register Write Disable (SRWD) bit, non-volatile bit, default value is "0". SRWD bit is operated together with Write Protection (WP#/SIO2) pin for providing hardware protection mode. The hardware protection mode requires SRWD sets to 1 and WP#/SIO2 pin signal is low stage. In the hardware protection mode, the Write Status Register (WRSR) instruction is no longer accepted for execution and the SRWD bit and Block Protect bits (BP3, BP2, BP1, BP0) are read only.

Status Register

bit7	bit6	bit5	bit4	bit3	bit2	bit1	bit0
SRWD (status register write protect)	QE (Quad Enable)	BP3 (level of protected block)	BP2 (level of protected block)	BP1 (level of protected block)	BP0 (level of protected block)	WEL (write enable latch)	WIP (write in progress bit)
1=status register write disable	1= Quad Enable 0=not Quad Enable	(note 1)	(note 1)	(note 1)	(note 1)	1=write enable 0=not write enable	1=write operation 0=not in write operation
Non-volatile bit	Non-volatile bit	Non-volatile bit	Non-volatile bit	Non-volatile bit	Non-volatile bit	volatile bit	volatile bit

Note 1: see the Table 2 "Protected Area Size".

(5) Write Status Register (WRSR)

The WRSR instruction is for changing the values of Status Register Bits. Before sending WRSR instruction, the Write Enable (WREN) instruction must be decoded and executed to set the Write Enable Latch (WEL) bit in advance. The WRSR instruction can change the value of Block Protect (BP3, BP2, BP1, BP0) bits to define the protected area of memory (as shown in Table 2). The WRSR also can set or reset the Quad enable (QE) bit and set or reset the Status Register Write Disable (SRWD) bit in accordance with Write Protection (WP#/SIO2) pin signal, but has no effect on bit1(WEL) and bit0 (WIP) of the status register. The WRSR instruction cannot be executed once the Hardware Protected Mode (HPM) is entered.

The sequence of issuing WRSR instruction is: CS# goes low→ sending WRSR instruction code→ Status Register data on SI→ CS# goes high. (see Figure 16)

The CS# must go high exactly at the byte boundary; otherwise, the instruction will be rejected and not executed. The self-timed Write Status Register cycle time (tW) is initiated as soon as Chip Select (CS#) goes high. The Write in Progress (WIP) bit still can be check out during the Write Status Register cycle is in progress. The WIP sets 1 during the tW timing, and sets 0 when Write Status Register Cycle is completed, and the Write Enable Latch (WEL) bit is reset.

Protection Modes

Mode	Status register condition	WP# and SRWD bit status	Memory
Software protection mode(SPM)	Status register can be written in (WEL bit is set to "1") and the SRWD, BP0-BP3 bits can be changed	WP#=1 and SRWD bit=0, or WP#=0 and SRWD bit=0, or WP#=1 and SRWD=1	The protected area cannot be program or erase.
Hardware protection mode (HPM)	The SRWD, BP0-BP3 of status register bits cannot be changed	WP#=0, SRWD bit=1	The protected area cannot be program or erase.

Note: As defined by the values in the Block Protect (BP3, BP2, BP1, BP0) bits of the Status Register, as shown in Table 2.

As the above table showing, the summary of the Software Protected Mode (SPM) and Hardware Protected Mode (HPM).

Software Protected Mode (SPM):

- When SRWD bit=0, no matter WP#/SIO2 is low or high, the WREN instruction may set the WEL bit and can change the values of SRWD, BP3, BP2, BP1, BP0. The protected area, which is defined by BP3, BP2, BP1, BP0, is at software protected mode (SPM).
- When SRWD bit=1 and WP#/SIO2 is high, the WREN instruction may set the WEL bit can change the values of SRWD, BP3, BP2, BP1, BP0. The protected area, which is defined by BP3, BP2, BP1, BP0, is at software protected mode (SPM)

Hardware Protected Mode (HPM):

- When SRWD bit=1, and then WP#/SIO2 is low (or WP#/SIO2 is low before SRWD bit=1), it enters the hardware protected mode (HPM). The data of the protected area is protected by software protected mode by BP3, BP2, BP1, BP0 and hardware protected mode by the WP#/SIO2 to against data modification.

Note:

To exit the hardware protected mode requires WP#/SIO2 driving high once the hardware protected mode is entered. If the WP#/SIO2 pin is permanently connected to high, the hardware protected mode can never be entered; only can use software protected mode via BP3, BP2, BP1, BP0.

If the system goes into four I/O mode, the feature of HPM will be disabled.

(6) Read Data Bytes (READ)

The read instruction is for reading data out. The address is latched on rising edge of SCLK, and data shifts out on the falling edge of SCLK at a maximum frequency f_R . The first address byte can be at any location. The address is automatically increased to the next higher address after each byte data is shifted out, so the whole memory can be read out at a single READ instruction. The address counter rolls over to 0 when the highest address has been reached.

The sequence of issuing READ instruction is: CS# goes low→ sending READ instruction code→3-byte address on SI →data out on SO→ to end READ operation can use CS# to high at any time during data out. (see Figure 17)

(7) Read Data Bytes at Higher Speed (FAST_READ)

The FAST_READ instruction is for quickly reading data out. The address is latched on rising edge of SCLK, and data of each bit shifts out on the falling edge of SCLK at a maximum frequency f_C . The first address byte can be at any location. The address is automatically increased to the next higher address after each byte data is shifted out, so the whole memory can be read out at a single FAST_READ instruction. The address counter rolls over to 0 when the highest address has been reached.

The sequence of issuing FAST_READ instruction is: CS# goes low→sending FAST_READ instruction code→3-byte address on SI→ 1-dummy byte (default) address on SI→data out on SO→ to end FAST_READ operation can use CS# to high at any time during data out. (see Figure 18)

While Program/Erase/Write Status Register cycle is in progress, FAST_READ instruction is rejected without any impact on the Program/Erase/Write Status Register current cycle.

(8) 2 x I/O Read Mode (2READ)

The 2READ instruction enables Double Transfer Rate of Serial Flash in read mode. The address is latched on rising edge of SCLK, and data of every two bits(interleave on 2 I/O pins) shift out on the falling edge of SCLK at a maximum frequency f_T . The first address byte can be at any location. The address is automatically increased to the next higher address after each byte data is shifted out, so the whole memory can be read out at a single 2READ instruction. The address counter rolls over to 0 when the highest address has been reached. Once writing 2READ instruction, the following address/dummy/data out will perform as 2-bit instead of previous 1-bit.

The sequence of issuing 2READ instruction is: CS# goes low→ sending 2READ instruction→ 24-bit address interleave on SIO1 & SIO0→ 4-bit dummy cycle on SIO1 & SIO0→ data out interleave on SIO1 & SIO0→ to end 2READ operation can use CS# to high at any time during data out (see Figure 20 for 2 x I/O Read Mode Timing Waveform).

While Program/Erase/Write Status Register cycle is in progress, 2READ instruction is rejected without any impact on the Program/Erase/Write Status Register current cycle.

(9) 4 x I/O Read Mode (4READ)

The 4READ instruction enables quad throughput of Serial Flash in read mode. A Quad Enable (QE) bit of status Register must be set to "1" before sending the 4READ instruction. The address is latched on rising edge of SCLK, and data of every four bits(interleave on 4 I/O pins) shift out on the falling edge of SCLK at a maximum frequency f_Q . The first address byte can be at any location. The address is automatically increased to the next higher address after each byte data is shifted out, so the whole memory can be read out at a single 4READ instruction. The address

counter rolls over to 0 when the highest address has been reached. Once writing 4READ instruction, the following address/dummy/data out will perform as 4-bit instead of previous 1-bit.

The sequence of issuing 4READ instruction is: CS# goes low → sending 4READ instruction → 24-bit address interleave on SIO3, SIO2, SIO1 & SIO0 → 6 dummy cycles → data out interleave on SIO3, SIO2, SIO1 & SIO0 → to end 4READ operation can use CS# to high at any time during data out (see Figure 22 for 4 x I/O Read Mode Timing Waveform).

Another sequence of issuing 4 READ instruction especially useful in random access is : CS# goes low → sending 4 READ instruction → 3-bytes address interleave on SIO3, SIO2, SIO1 & SIO0 → performance enhance toggling bit P[7:0] → 4 dummy cycles → data out still CS# goes high → CS# goes low (reduce 4 Read instruction) → 24-bit random access address (see Figure 23 for 4x I/O Read Enhance Performance Mode timing waveform).

In the performance-enhancing mode (Note of Figure. 23), P[7:4] must be toggling with P[3:0] ; likewise P[7:0]=A5h,5Ah,F0h or 0Fh can make this mode continue and reduce the next 4READ instruction. Once P[7:4] is no longer toggling with P[3:0]; likewise P[7:0]=FFh,00h,AAh or 55h. These commands will reset the performance enhance mode. And afterwards CS# is raised and then lowered, the system then will return to normal operation.

While Program/Erase/Write Status Register cycle is in progress, 4READ instruction is rejected without any impact on the Program/Erase/Write Status Register current cycle.

(10) Fast Double Transfer Rate Read (FASTDTRD)

The FASTDTRD instruction is for doubling reading data out, signals are triggered on both rising and falling edge of clock. The address is latched on both rising and falling edge of SCLK, and data of each bit shifts out on both rising and falling edge of SCLK at a maximum frequency fC2. The 2-bit address can be latched-in at one clock, and 2-bit data can be read out at one clock, which means one bit at rising edge of clock, the other bit at falling edge of clock. The first address byte can be at any location.

The address is automatically increased to the next higher address after each byte data is shifted out, so the whole memory can be read out at a single FASTDTRD instruction. The address counter rolls over to 0 when the highest address has been reached.

The sequence of issuing FASTDTRD instruction is: CS# goes low → sending FASTDTRD instruction code (1bit per clock) → 3-byte address on SI (2-bit per clock) → 6-dummy clocks (default) on SI → data out on SO (2-bit per clock) → to end FASTDTRD operation can use CS# to high at any time during data out. (see Figure 19)

While Program/Erase/Write Status Register cycle is in progress, FASTDTRD instruction is rejected without any impact on the Program/Erase/Write Status Register current cycle.

(11) 2 x I/O Double Transfer Rate Read Mode (2DTRD)

The 2DTRD instruction enables Double Transfer Rate throughput on dual I/O of Serial Flash in read mode. The address (interleave on dual I/O pins) is latched on both rising and falling edge of SCLK, and data (interleave on dual I/O pins) shift out on both rising and falling edge of SCLK at a maximum frequency fT2. The 4-bit address can be latched-in at one clock, and 4-bit data can be read out at one clock, which means two bits at rising edge of clock, the other two bits at falling edge of clock. The first address byte can be at any location.

The address is automatically increased to the next higher address after each byte data is shifted out, so the whole memory can be read out at a single 2DTRD instruction. The address counter rolls over to 0 when the highest address has been reached. Once writing 2DTRD instruction, the following address/dummy/ data out will perform as

4-bit instead of previous 1-bit.

The sequence of issuing 2DTRD instruction is: CS# goes low → sending 2DTRD instruction (1-bit per clock) → 24-bit address interleave on SIO1 & SIO0 (4-bit per clock) → 6-bit dummy clocks on SIO1 & SIO0 → data out interleave on SIO1 & SIO0 (4-bit per clock) → to end 2DTRD operation can use CS# to high at any time during data out (see Figure 21 for 2 x I/O Double Transfer Rate Read Mode Timing Waveform).

While Program/Erase/Write Status Register cycle is in progress, 2DTRD instruction is rejected without any impact on the Program/Erase/Write Status Register current cycle.

(12) 4 x I/O Double Transfer Rate Read Mode (4DTRD)

The 4DTRD instruction enables Double Transfer Rate throughput on quad I/O of Serial Flash in read mode. A Quad Enable (QE) bit of status Register must be set to "1" before sending the 4DTRD instruction. The address(interleave on 4 I/O pins) is latched on both rising and falling edge of SCLK, and data (interleave on 4 I/O pins) shift out on both rising and falling edge of SCLK at a maximum frequency $fQ2$. The 8-bit address can be latched-in at one clock, and 8-bit data can be read out at one clock, which means four bits at rising edge of clock, the other four bits at falling edge of clock. The first address byte can be at any location. The address is automatically increased to the next higher address after each byte data is shifted out, so the whole memory can be read out at a single 4DTRD instruction. The address counter rolls over to 0 when the highest address has been reached. Once writing 4DTRD instruction, the following address/dummy/data out will perform as 8-bit instead of previous 1-bit.

The sequence of issuing 4DTRD instruction is: CS# goes low → sending 4DTRD instruction (1-bit per clock) → 24-bit address interleave on SIO3, SIO2, SIO1 & SIO0 (8-bit per clock) → 8 dummy clocks → data out interleave on SIO3, SIO2, SIO1 & SIO0 (8-bit per clock) → to end 4DTRD operation can use CS# to high at any time during data out (see Figure 24 for 4 x I/O Read Mode Double Transfer Rate Timing Waveform).

Another sequence of issuing enhanced mode of 4DTRD instruction especially useful in random access is : CS# goes low → sending 4DTRD instruction (1-bit per clock) → 3-bytes address interleave on SIO3, SIO2, SIO1 & SIO0 (8-bit per clock) → performance enhance toggling bit P[7:0] → 7 dummy clocks → data out(8-bit per clock) still CS# goes high → CS# goes low (eliminate 4 Read instruction) → 24-bit random access address (see Figure 25 for 4x I/O Double Transfer Rate read enhance performance mode timing waveform).

While Program/Erase/Write Status Register cycle is in progress, 4DTRD instruction is rejected without any impact on the Program/Erase/Write Status Register current cycle.

(13) Sector Erase (SE)

The Sector Erase (SE) instruction is for erasing the data of the chosen sector to be "1". The instruction is used for any 4K-byte sector. A Write Enable (WREN) instruction must execute to set the Write Enable Latch (WEL) bit before sending the Sector Erase (SE). Any address of the sector (see Table 6) is a valid address for Sector Erase (SE) instruction. The CS# must go high exactly at the byte boundary (the latest eighth of address byte been latched-in); otherwise, the instruction will be rejected and not executed.

Address bits [Am-A12] (Am is the most significant address) select the sector address.

The sequence of issuing SE instruction is: CS# goes low → sending SE instruction code → 3-byte address on SI → CS# goes high. (see Figure 29)

The self-timed Sector Erase Cycle time (t_{SE}) is initiated as soon as Chip Select (CS#) goes high. The Write in Progress (WIP) bit still can be check out during the Sector Erase cycle is in progress. The WIP sets 1 during the

tSE timing, and sets 0 when Sector Erase Cycle is completed, and the Write Enable Latch (WEL) bit is reset. If the sector is protected by BP3~0 (WPSEL=0), RL7~0, or by individual lock/permanent lock (WPSEL=1), the array data will be protected (no change) and the WEL bit still be reset.

(14) Block Erase (BE)

The Block Erase (BE) instruction is for erasing the data of the chosen block to be "1". The instruction is used for 64K-byte block erase operation. A Write Enable (WREN) instruction must execute to set the Write Enable Latch (WEL) bit before sending the Block Erase (BE). Any address of the block (see table 6) is a valid address for Block Erase (BE) instruction. The CS# must go high exactly at the byte boundary (the latest eighth of address byte been latched-in); otherwise, the instruction will be rejected and not executed.

The sequence of issuing BE instruction is: CS# goes low → sending BE instruction code → 3-byte address on SI → CS# goes high. (see Figure 30)

The self-timed Block Erase Cycle time (tBE) is initiated as soon as Chip Select (CS#) goes high. The Write in Progress (WIP) bit still can be check out during the Sector Erase cycle is in progress. The WIP sets 1 during the tBE timing, and sets 0 when Sector Erase Cycle is completed, and the Write Enable Latch (WEL) bit is reset. If the block is protected by BP3~0 (WPSEL=0), RL7~0, or by individual lock/permanent lock (WPSEL=1), the array data will be protected (no change) and the WEL bit still be reset.

(15) Block Erase (BE32K)

The Block Erase (BE32) instruction is for erasing the data of the chosen block to be "1". The instruction is used for 32K-byte block erase operation. A Write Enable (WREN) instruction must execute to set the Write Enable Latch (WEL) bit before sending the Block Erase (BE32). Any address of the block (see table 6) is a valid address for Block Erase (BE32) instruction. The CS# must go high exactly at the byte boundary (the latest eighth of address byte been latched-in); otherwise, the instruction will be rejected and not executed.

The sequence of issuing BE32 instruction is: CS# goes low → sending BE32 instruction code → 3-byte address on SI → CS# goes high.

The self-timed Block Erase Cycle time (tBE) is initiated as soon as Chip Select (CS#) goes high. The Write in Progress (WIP) bit still can be check out during the Sector Erase cycle is in progress. The WIP sets 1 during the tBE timing, and sets 0 when Sector Erase Cycle is completed, and the Write Enable Latch (WEL) bit is reset. If the block is protected by BP3~0 (WPSEL=0), RL7~0, or by individual lock/permanent lock (WPSEL=1), the array data will be protected (no change) and the WEL bit still be reset.

(16) Chip Erase (CE)

The Chip Erase (CE) instruction is for erasing the data of the whole chip to be "1". A Write Enable (WREN) instruction must execute to set the Write Enable Latch (WEL) bit before sending the Chip Erase (CE). The CS# must go high exactly at the byte boundary; otherwise, the instruction will be rejected and not executed.

The sequence of issuing CE instruction is: CS# goes low → sending CE instruction code → CS# goes high. (see Figure 31)

The self-timed Chip Erase Cycle time (tCE) is initiated as soon as Chip Select (CS#) goes high. The Write in Progress (WIP) bit still can be check out during the Chip Erase cycle is in progress. The WIP sets 1 during the tCE timing, and sets 0 when Chip Erase Cycle is completed, and the Write Enable Latch (WEL) bit is reset. If the chip is

protected the Chip Erase (CE) instruction will not be executed, but WEL will be reset.

(17) Page Program (PP)

The Page Program (PP) instruction is for programming the memory to be "0". A Write Enable (WREN) instruction must execute to set the Write Enable Latch (WEL) bit before sending the Page Program (PP). The device programs only the last 256 data bytes sent to the device. If the entire 256 data bytes are going to be programmed, A7-A0 (The eight least significant address bits) should be set to 0. If the eight least significant address bits (A7-A0) are not all 0, all transmitted data going beyond the end of the current page are programmed from the start address of the same page (from the address A7-A0 are all 0). If more than 256 bytes are sent to the device, the data of the last 256-byte is programmed at the request page and previous data will be disregarded. If less than 256 bytes are sent to the device, the data is programmed at the requested address of the page without effect on other address of the same page.

The sequence of issuing PP instruction is: CS# goes low→ sending PP instruction code→ 3-byte address on SI→at least 1-byte on data on SI→ CS# goes high. (see Figure 26)

The CS# must be kept to low during the whole Page Program cycle; The CS# must go high exactly at the byte boundary(the latest eighth bit of data being latched in), otherwise, the instruction will be rejected and will not be executed.

The self-timed Page Program Cycle time (t_{PP}) is initiated as soon as Chip Select (CS#) goes high. The Write in Progress (WIP) bit still can be check out during the Page Program cycle is in progress. The WIP sets 1 during the t_{PP} timing, and sets 0 when Page Program Cycle is completed, and the Write Enable Latch (WEL) bit is reset. If the page is protected by BP3~0 (WPSEL=0), RL7~0, or by individual lock/permanent lock (WPSEL=1), the array data will be protected (no change) and the WEL bit will still be reset.

(18) 4 x I/O Page Program (4PP)

The Quad Page Program (4PP) instruction is for programming the memory to be "0". A Write Enable (WREN) instruction must execute to set the Write Enable Latch (WEL) bit and Quad Enable (QE) bit must be set to "1" before sending the Quad Page Program (4PP). The Quad Page Programming takes four pins: SIO0, SIO1, SIO2, and SIO3, which can raise programer performance and and the effectiveness of application of lower clock less than 20MHz. For system with faster clock, the Quad page program cannot provide more actual favors, because the required internal page program time is far more than the time data flows in. Therefore, we suggest that while executing this command (especially during sending data), user can slow the clock speed down to 20MHz below. The other function descriptions are as same as standard page program.

The sequence of issuing 4PP instruction is: CS# goes low→ sending 4PP instruction code→ 3-byte address on SIO[3:0]→ at least 1-byte on data on SIO[3:0]→ CS# goes high. (see Figure 27)

If the page is protected by BP3~0 (WPSEL=0), RL7~0, or by individual lock/permanent lock (WPSEL=1), the array data will be protected (no change) and the WEL bit will still be reset.

The Program/Erase function instruction function flow is as follows:

Program/Erase Flow(1) with read array data

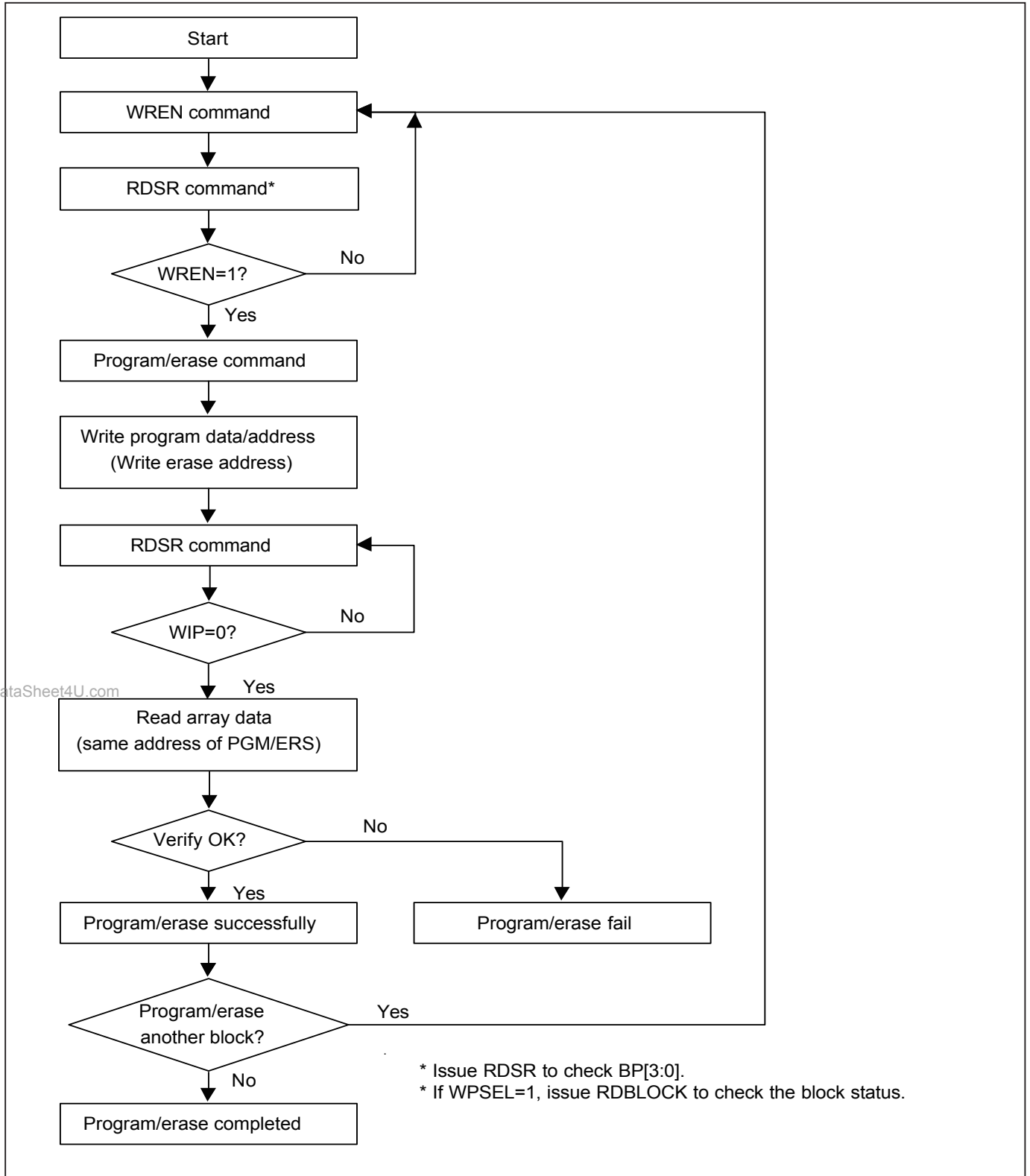

Program/Erase Flow(2) without read array data

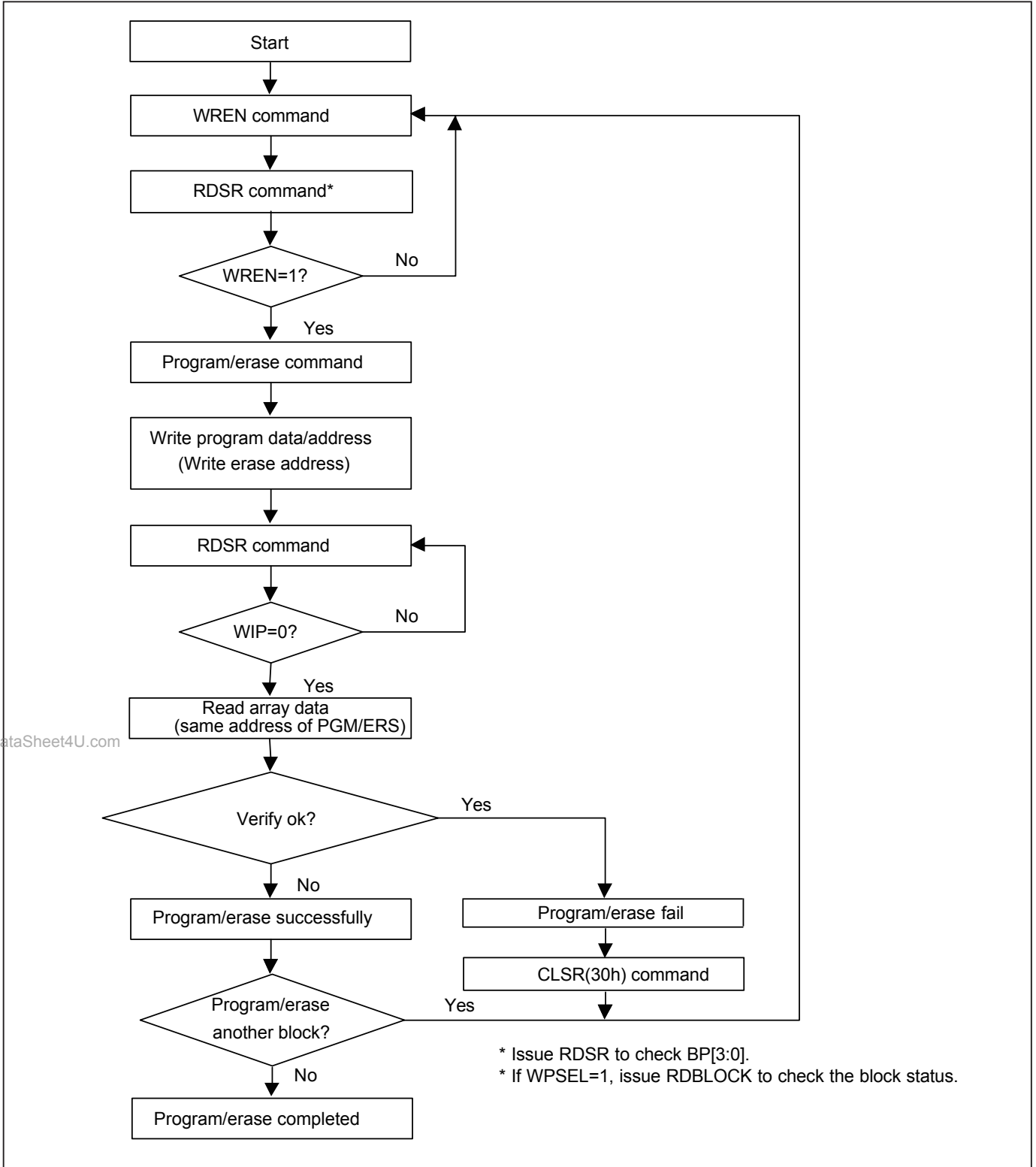

(19) Continuously program mode (CP mode)

The CP mode may enhance program performance by automatically increasing address to the next higher address after each byte data has been programmed.

The Continuously program (CP) instruction is for multiple byte program to Flash. A write Enable (WREN) instruction must execute to set the Write Enable Latch(WEL) bit before sending the Continuously program (CP) instruction. CS# requires to go high before CP instruction is executing. After CP instruction and address input, two bytes of data is input sequentially from MSB(bit7) to LSB(bit0). The first byte data will be programmed to the initial address range with A0=0 and second byte data with A0=1. If only one byte data is input, the CP mode will not process. If more than two bytes data are input, the additional data will be ignored and only two byte data are valid. Any byte to be programmed should be in the erase state (FF) first. It will not roll over during the CP mode, once the last unprotected address has been reached, the chip will exit CP mode and reset write Enable Latch bit (WEL) as "0" and CP mode bit as "0". Please check the WIP bit status if it is not in write progress before entering next valid instruction. During CP mode, the valid commands are CP command (AD hex), WRDI command (04 hex), RDSR command (05 hex), and RDSCUR command (2B hex). And the WRDI command is valid after completion of a CP programming cycle, which means the WIP bit=0.

The sequence of issuing CP instruction is : CS# high to low→ sending CP instruction code → 3-byte address on SI pin→ two data bytes on SI → CS# goes high to low → sending CP instruction and then continue two data bytes are programmed→ CS# goes high to low→ till last desired two data bytes are programmed → CS# goes high to low→ sending WRDI (Write Disable) instruction to end CP mode → send RDSR instruction to verify if CP mode word program ends, or send RDSCUR to check bit4 to verify if CP mode ends. (see Figure 28 of CP mode timing waveform)

Three methods to detect the completion of a program cycle during CP mode:

- 1) Software method-I: by checking WIP bit of Status Register to detect the completion of CP mode.
- 2) Software method-II: by waiting for a tBP time out to determine if it may load next valid command or not.
- 3) Hardware method: by writing ESRY (enable SO to output RY/BY#) instruction to detect the completion of a program cycle during CP mode. The ESRY instruction must be executed before CP mode execution. Once it is enable in CP mode, the CS# goes low will drive out the RY/BY# status on SO, "0" indicates busy stage, "1" indicates ready stage, SO pin outputs tri-state if CS# goes high. DSRY (disable SO to output RY/BY#) instruction to disable the SO to output RY/BY# and return to status register data output during CP mode. Please note that the ESRY/DSRY command are not accepted unless the completion of CP mode.

If the page is protected by BP3~0 (WPSEL=0), RL7~0, or by individual lock/permanent lock (WPSEL=1), the array data will be protected (no change) and the WEL bit will still be reset.

(20) Parallel Mode (Highly recommended for production throughputs increasing)

The parallel mode provides 8 bit inputs/outputs for increasing throughputs of factory production purpose. The parallel mode requires 55h command code, after writing the parallel mode command and then CS# going high, after that, the Memory can be available to accept read/program/read status/read ID/RES/REMS command as the normal writing command procedure.

- a. Only effective for Read Array for normal read(not FAST_READ), Read ID, Page Program, RES and REMS write data period.
- b. For normal write command (by SI), No effect
- c. Under parallel mode, the fastest access clock freq. will be changed to 6MHz(SCLK pin clock freq.)
- d. For parallel mode, the tV will be change to 70ns.

(21) Deep Power-down (DP)

The Deep Power-down (DP) instruction is for setting the device on the minimizing the power consumption (to entering the Deep Power-down mode), the standby current is reduced from ISB1 to ISB2). The Deep Power-down mode requires the Deep Power-down (DP) instruction to enter, during the Deep Power-down mode, the device is not active and all Write/Program/Erase instruction are ignored. When CS# goes high, it's only in standby mode not deep power-down mode. It's different from Standby mode.

The sequence of issuing DP instruction is: CS# goes low→ sending DP instruction code→ CS# goes high. (see Figure 32)

Once the DP instruction is set, all instruction will be ignored except the Release from Deep Power-down mode (RDP) and Read Electronic Signature (RES) instruction. (those instructions allow the ID being reading out). When Power-down, the deep power-down mode automatically stops, and when power-up, the device automatically is in standby mode. For RDP instruction the CS# must go high exactly at the byte boundary (the latest eighth bit of instruction code been latched-in); otherwise, the instruction will not executed. As soon as Chip Select (CS#) goes high, a delay of tDP is required before entering the Deep Power-down mode and reducing the current to ISB2.

(22) Release from Deep Power-down (RDP), Read Electronic Signature (RES)

The Release from Deep Power-down (RDP) instruction is terminated by driving Chip Select (CS#) High. When Chip Select (CS#) is driven High, the device is put in the standby Power mode. If the device was not previously in the Deep Power-down mode, the transition to the standby Power mode is immediate. If the device was previously in the Deep Power-down mode, though, the transition to the standby Power mode is delayed by tRES2, and Chip Select (CS#) must remain High for at least tRES2(max), as specified in Table 10. Once in the standby mode, the device waits to be selected, so that it can receive, decode and execute instructions.

RES instruction is for reading out the old style of 8-bit Electronic Signature, whose values are shown as table of ID Definitions. This is not the same as RDID instruction. It is not recommended to use for new design. For new design, please use RDID instruction. Even in Deep power-down mode, the RDP and RES are also allowed to be executed, only except the device is in progress of program/erase/write cycles; there's no effect on the current program/erase/write cycles in progress. The sequence is shown as Figure 33,34.

The RES instruction is ended by CS# goes high after the ID been read out at least once. The ID outputs repeatedly if continuously send the additional clock cycles on SCLK while CS# is at low. If the device was not previously in Deep Power-down mode, the device transition to standby mode is immediate. If the device was previously in Deep Power-down mode, there's a delay of tRES2 to transit to standby mode, and CS# must remain to high at least tRES2(max). Once in the standby mode, the device waits to be selected, so it can be receive, decode, and execute instruction.

The RDP instruction is for releasing from Deep Power-down Mode.

(23) Read Electronic Manufacturer ID & Device ID (REMS), (REMS2), (REMS4), (REMS4D)

The REMS, REMS2, REMS4 and REMS4D instruction provides both the JEDEC assigned Manufacturer ID and the specific Device ID.

The instruction is initiated by driving the CS# pin low and shift the instruction code "90h", "EFh", "DFh" or "CFh" followed by two dummy bytes and one bytes address (A7~A0). After which, the Manufacturer ID for MXIC (C2h) and the Device ID are shifted out on the falling edge of SCLK with most significant bit (MSB) first as shown in Figure 35. The Device ID values are listed in table of ID Definitions. If the one-byte address is initially set to 01h, then the De-

vice ID will be read first and then followed by the Manufacturer ID. The Manufacturer and Device IDs can be read continuously, alternating from one to the other. The instruction is completed by driving CS# high.

Table 6. ID Definitions

RDID Command	manufacturer ID	memory type	memory density
	C2	26	18
RES Command	electronic ID		
	88		
REMS/REMS2/REMS4/ REMS4D Command	manufacturer ID	device ID	
	C2	88	

(24) Enter Secured OTP (ENSO)

The ENSO instruction is for entering the additional 4K-bit Secured OTP mode. The additional 4K-bit Secured OTP is independent from main array, which may use to store unique serial number for system identifier. After entering the Secured OTP mode, and then follow standard read or program, procedure to read out the data or update data. The Secured OTP data cannot be updated again once it is lock-down.

The sequence of issuing ENSO instruction is: CS# goes low→sending ENSO instruction to enter Secured OTP mode→ CS# goes high.

Please note that WRSR/WRSCUR/WPSEL/SBLK/GBLK/SBULK/GBULK/CE/BE/SE/BE32K commands are not acceptable during the access of secure OTP region, once Security OTP is lock down, only read related commands are valid.

(25) Exit Secured OTP (EXSO)

The EXSO instruction is for exiting the additional 4K-bit Secured OTP mode.

www.DataSheet4U.com

The sequence of issuing EXSO instruction is: CS# goes low→ sending EXSO instruction to exit Secured OTP mode→ CS# goes high.

(26) Read Security Register (RDSCUR)

The RDSCUR instruction is for reading the value of Security Register. The Read Security Register can be read at any time (even in program/erase/write status register/write security register condition) and continuously.

The sequence of issuing RDSCUR instruction is : CS# goes low→ send ing RDSCUR instruction → Security Register data out on SO→ CS# goes high.

The definition of the Security Register is as below:

Secured OTP Indicator bit. The Secured OTP indicator bit shows the chip is locked by factory before ex- factory or not. When it is "0", it indicates non- factory lock; "1" indicates factory- lock.

Lock-down Secured OTP (LDSO) bit. By writing WRSCUR instruction, the LDSO bit may be set to "1" for customer lock-down purpose. However, once the bit is set to "1" (lock-down), the LDSO bit and the 4K-bit Secured OTP area cannot be update any more. While it is in 4K-bit Secured OTP mode, array access is not allowed.

Continuously Program Mode(CP mode) bit. The Continuously Program Mode bit indicates the status of CP mode, "0" indicates not in CP mode; "1" indicates in CP mode.

Program Fail Flag bit. While a program failure happened, the Program Fail Flag bit would be set. This bit will also be set when the user attempts to program a protected main memory region or a locked OTP region. This bit can indicate whether one or more of program operations fail, and can be reset by command CLSR (30h)

Erase Fail Flag bit. While a erase failure happened, the Erase Fail Flag bit would be set. This bit will also be set when the user attempts to erase a protected main memory region or a locked OTP region. This bit can indicate whether one or more of erase operations fail, and can be reset by command CLSR (30h)

Write Protection Select bit. The Write Protection Select bit indicates that WPSEL has been executed successfully. Once this bit has been set (WPSEL=1), all the blocks or sectors will be write-protected after the power-on every time. Once WPSEL has been set, it cannot be changed again, which means it's only for individual WP mode.

Under the individual block protection mode (WPSEL=1), hardware protection is performed by driving WP#=0. Once WP#=0 all array blocks/sectors are protected regardless of the contents of SRAM lock bits and Permanent Lock bits.

Security Register Definition

bit7	bit6	bit5	bit4	bit3	bit2	bit1	bit0
WPSEL	E_FAIL	P_FAIL	Continuously Program mode (CP mode)	x	x	LDSO (indicate if lock-down)	Secured OTP indicator bit
0=normal WP mode 1=individual WP mode (default=0)	0=normal Erase succeed 1=indicate Erase failed (default=0)	0=normal Program succeed 1=indicate Program failed (default=0)	0=normal Program mode 1=CP mode (default=0)	reserved	reserved	0 = not lockdown 1 = lock-down (cannot program/erase OTP)	0 = nonfactory lock 1 = factory lock
non-volatile bit	volatile bit	volatile bit	volatile bit	volatile bit	volatile bit	non-volatile bit	non-volatile bit

(27) Write Security Register (WRSCUR)

The WRSCUR instruction is for changing the values of Security Register Bits. Unlike write status register, the WREN instruction is not required before sending WRSCUR instruction. The WRSCUR instruction may change the values of bit1 (LDSO bit) for customer to lock-down the 4K-bit Secured OTP area. Once the LDSO bit is set to "1", the Secured OTP area cannot be updated any more.

The sequence of issuing WRSCUR instruction is :CS# goes low-> sending WRSCUR instruction -> CS# goes high.

The CS# must go high exactly at the boundary; otherwise, the instruction will be rejected and not executed.

(28) GPIO Expander

GPIO expander is used for microcontrollers to expand the general purpose I/O pin with 7 extra General Purpose Input/Outputs. The outputs provided can be used for controlling simple on-off of system components.

(28-1) GPIO Function Enable (GPIOEN)

The GPIOEN instruction is for enabling the function of GPIO mode. For all of GPIO commands like GPIORW, GPIORST, and GPIODIS, they should be issued after GPIOEN is set. GPIO is not allowed in parallel mode and POR read, but it is allowed in the other modes even in Deep Power down (DPW). If GPIO is active in DPW mode, the I_{SB2} may increase more than 40uA (see Table 9).

The sequence of issuing GPIOEN instruction is: CS# goes low -> GPIOEN instruction code is sent -> CS# goes high.

The CS# must go high exactly at the byte boundary; otherwise, the instruction will be rejected and not executed.

(28-2) GPIO Function Disable (GPIODIS)

The GPIODIS instruction is for disabling the function of GPIO mode. Moreover, the GPIO function is also disabled after POR, and all of the GPIO registers will be reset if GPIO function is disabled. GPIOEN should be issued before the setting of GPIODIS instruction to make sure the GPIO function is enabled, or the GPIODIS instruction will not be executed. After GPIODIS is issued, other GPIO command will not be executed until GPIOEN is set again.

The sequence of issuing GPIODIS instruction is: CS# goes low -> GPIODIS instruction code is sent -> CS# goes high.

The CS# must go high exactly at the byte boundary; otherwise, the instruction will be rejected and not executed.

www.DataSheet4U.com

(28-3) GPIO Register Read/Write (GPIORW)

The GPIORW instruction is for changing the GPIO registers. Read and Write operation can be judged by bit7 of address byte. Read operation will be executed when bit7 = 1 and write operation will be executed when bit7 = 0. The read/write operation is described in Table 10. GPIOEN should be issued before the setting of GPIORW instruction to make sure the GPIO function is enabled, or the GPIORW instruction will not be executed.

The sequence of issuing GPIORW instruction is: CS# goes low -> GPIORW instruction code is sent -> issue R/W# bit (Write as 0; Read as 1) and address bit (A6~A0) -> SI/SO 8 bit data in/out cycle -> CS# goes high. The GPIO read/write waveform is shown as Figure 40 and Figure 41.

The CS# must go high exactly at the byte boundary; otherwise, the instruction will be rejected and not executed.

(28-4) GPIO Register Reset (GPIORST)

The GPIORST instruction is for resetting all the GPIO registers. The GPIO registers will be reset to 0 (default value) if GPIORST or POR is issued. GPIOEN should be issued before the setting of GPIORST instruction to make sure

the GPIO function is enabled, or the GPIORST instruction will not be executed.

The sequence of issuing GPIORST instruction is: CS# goes low -> GPIORST instruction code is sent -> CS# goes high.

The CS# must go high exactly at the byte boundary; otherwise, the instruction will be rejected and not executed.

GPIO register definition is as follows:

Register Name D[6:0]	Reg. Address A[6:0]	Description		Reg. Value after POR/GPIO reset
GPDC[6:0]	0x00	GPIO Pin Direction Configuration	0: Configured as input pin 1: Configured as output pin	0000000
GPOM[6:0]	0x01	GPIO Pin Output Mode	0: Open drain 1: Push-pull Valid only when GPDC[n]=1	0000000
GPWD[6:0]	0x02	GPIO Pin Write Data	0: Data="0" 1: Data="1" It's only valid for output pins.	0000000
GPST[6:0]	0x03	GPIO Pin Smitt Trigger enable	0: Disable 1: Enable	0000000
GPPU[6:0]	0x04	GPIO Pin pull-up resistor enable	0: Disable 1: ~50K Ω to VDD	0000000
GPPD[6:0]	0x05	GPIO Pin pull-down resistor enable	0: Disable 1: ~50K Ω to GND	0000000
GPDS[6:0]	0x06	GPIO Pin Driving Strength	0: 2mA (weak) 1: 4mA (strong)	0000000
GPRD[6:0]	0x07	GPIO Pin Read Data	0: data="0" 1: data="1"	0000000
GPII[6:0]	0x08	GPIO Pin Input Inversion	0: No inversion 1: Inversion enable	0000000
GPOI[6:0]	0x09	GPIO Pin Output Inversion	0: No inversion 1: Inversion enable	0000000
GPOS[6:0]	0x0C	GPIO one shot enable	0 : Disable 1 : Enable (When pin value is "1", keep "1" until GPRD[n] is written "1")	0000000

(29) Write Protection Selection (WPSEL)

When the system accepts and executes WPSEL instruction, the bit 7 in security register will be set. It will activate SBLK, SBULK, RDBLOCK, GBLK, GBULK etc instructions to conduct block lock protection and replace the original Software Protect Mode (SPM) use (BP3~BP0) indicated block methods.

The sequence of issuing WPSEL instruction is: CS# goes low → sending WPSEL instruction to enter the individual block protect mode → CS# goes high.

Every time after the system is powered-on, and the Security Register bit 7 is checked to be WPSEL=1, all the blocks or sectors will be write protected by default. User may only unlock the blocks or sectors via SBULK and GBULK instruction. Program or erase functions can only be operated after the Unlock instruction is conducted.

Under the individual block protection mode (WPSEL=1), hardware protection is performed by driving WP#=0. Once WP#=0 all array blocks/sectors are protected regardless of the contents of SRAM lock bits and Permanent Lock bits.

WPSEL instruction function flow is as follows:

WPSEL Flow

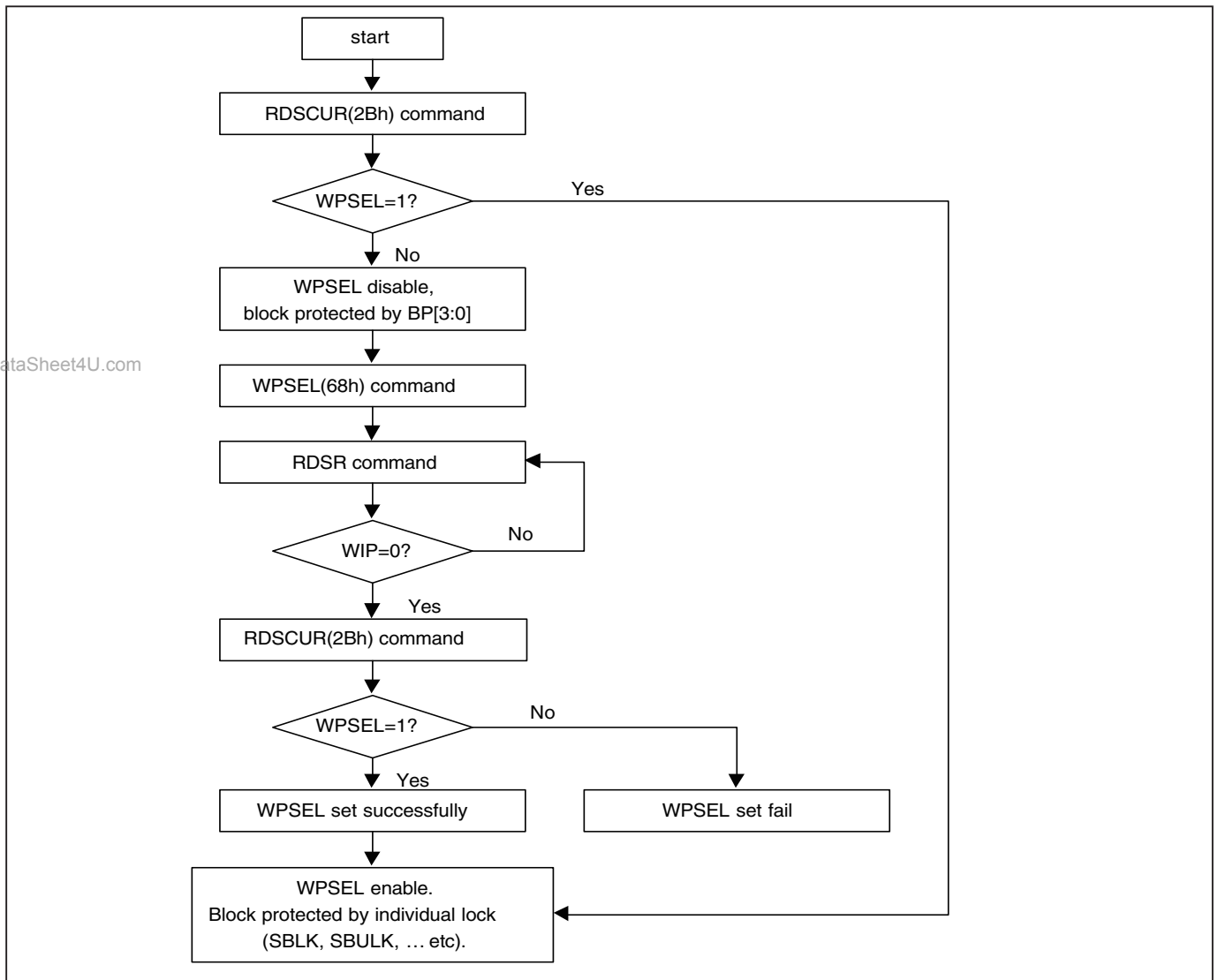

(30) Single Block Lock/Unlock Protection (SBLK/SBULK)

These instructions are only effective after WPSEL was executed. The SBLK instruction is for write protection a specified block(or sector) of memory, using A23-A16 or (A23-A12) address bits to assign a 64Kbyte block (or 4K bytes sector) to be protected as read only. The SBULK instruction will cancel the block (or sector) write protection state. This feature allows user to stop protecting the entire block (or sector) through the chip unprotect command (GBULK).

The WREN (Write Enable) instruction is required before issuing SBLK/SBULK instruction.

The sequence of issuing SBLK/SBULK instruction is: CS# goes low → send SBLK/SBULK (36h/39h) instruction → send 3 address bytes assign one block (or sector) to be protected on SI pin → CS# goes high. (see Figure 41) The CS# must go high exactly at the byte boundary, otherwise the instruction will be rejected and not be executed.

SBLK/SBULK instruction function flow is as follows:

Block Lock Flow

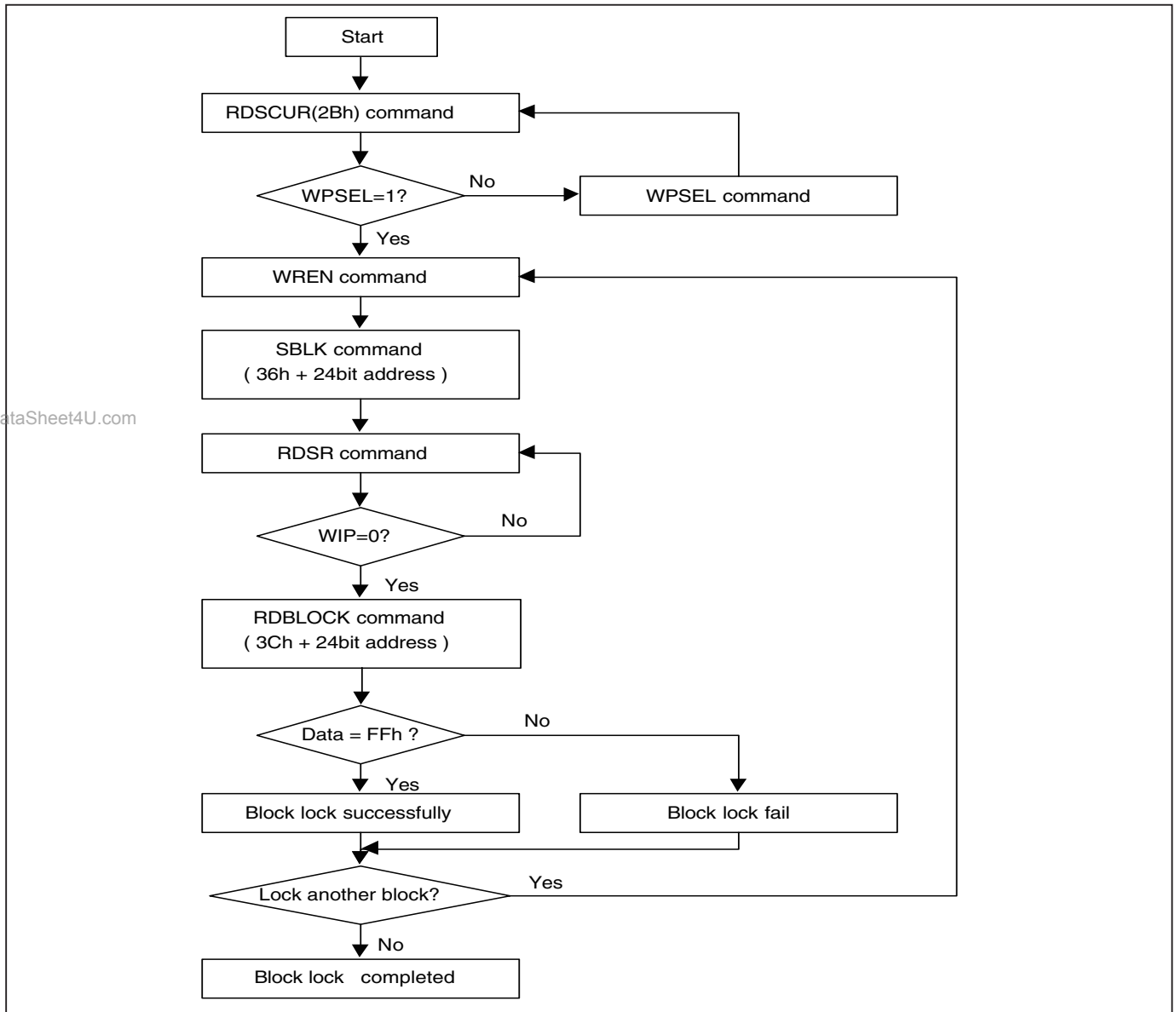

Block Unlock Flow

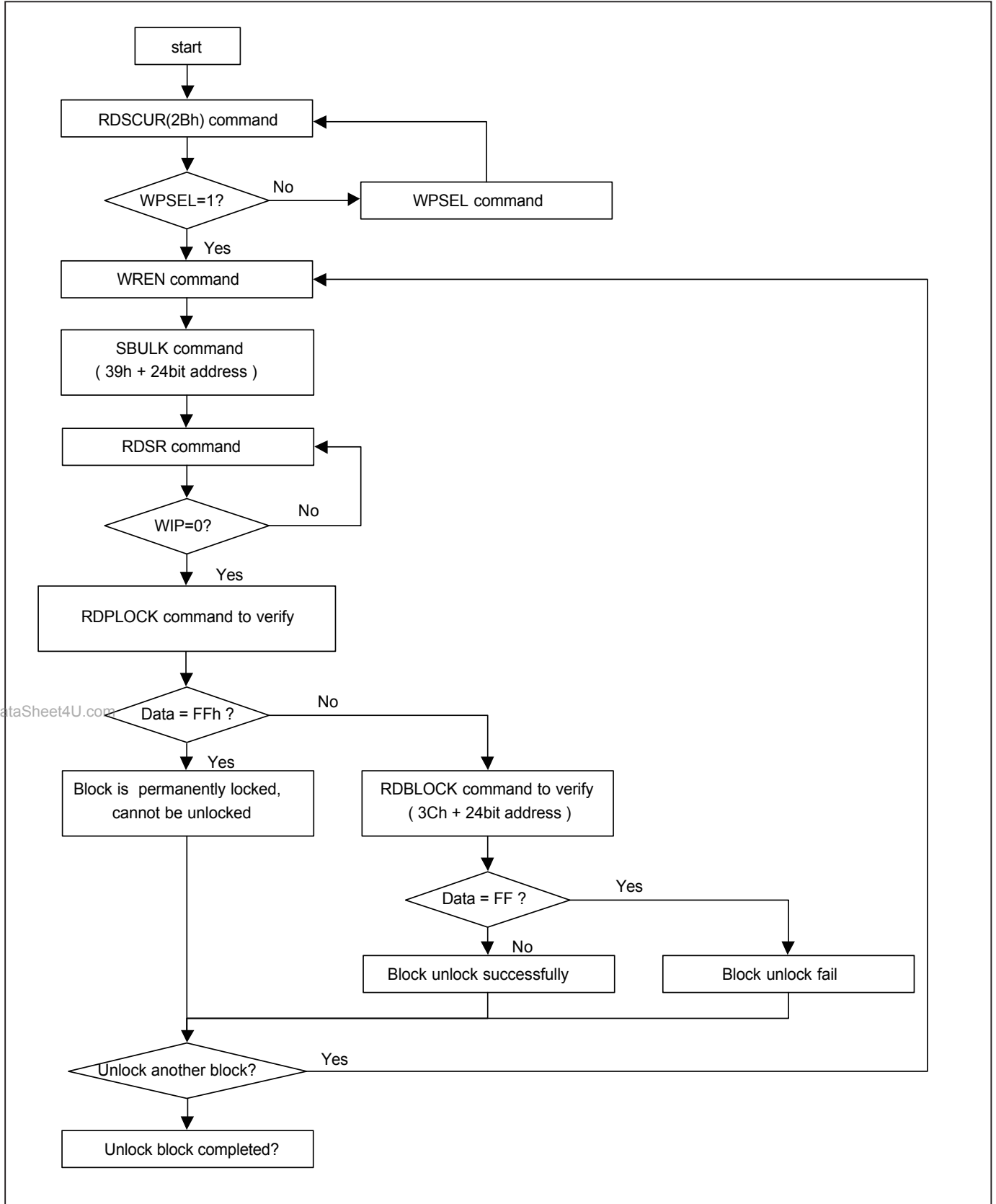

(31) Read Block Lock Status (RDBLOCK)

This instruction is only effective after WPSEL was executed. The RDBLOCK instruction is for reading the status of protection lock of a specified block(or sector), using A23-A16 (or A23-A12) address bits to assign a 64K bytes block (4K bytes sector) and read protection lock status bit which the first byte of Read-out cycle. The status bit is "1" to indicate that this block has be protected, that user can read only but cannot write/program /erase this block. The status bit is "0" to indicate that this block hasn't be protected, and user can read and write this block.

The sequence of issuing RDBLOCK instruction is: CS# goes low → send RDBLOCK (3Ch) instruction → send 3 address bytes to assign one block on SI pin → read block's protection lock status bit on SO pin → CS# goes high. (see Figure 42)

(32) Gang Block Lock/Unlock (GBLK/GBULK)

These instructions are only effective after WPSEL was executed. The GBLK/GBULK instruction is for enable/disable the lock protection block of the whole chip.

The WREN (Write Enable) instruction is required before issuing GBLK/GBULK instruction.

The sequence of issuing GBLK/GBULK instruction is: CS# goes low → send GBLK/GBULK (7Eh/98h) instruction → CS# goes high. (see Figure 43)

The CS# must go high exactly at the byte boundary, otherwise, the instruction will be rejected and not be executed.

(33) Clear SR Fail Flags (CLSR)

The CLSR instruction is for resetting the Program/Erase Fail Flag bit of Security Register. It should be executed before program/erase another block during programing/erasing flow without read array data.

The sequence of issuing CLSR instruction is: CS# goes low → send CLSR instruction code → CS# goes high.

The CS# must go high exactly at the byte boundary; otherwise, the instruction will be rejected and not executed.

(34) Output Driving Configure (ODC)

The ODC instruction is for changing the option value of output driving or sinking. The options of output current are shown as follow table. In this table, bit [3:2] is for PMOS driving option and bit [1:0] is for NMOS sinking option.

The sequence of issuing ODC instruction is: CS# goes low → send ODC instruction code → set 8bit ODC data on SI (bit [7:4] don't care) → CS# goes high.

The CS# must go high exactly at the byte boundary; otherwise, the instruction will be rejected and not executed.

Output Drive current option			Output Sink current option		
Bit [3:2]	Output Driving Current	Note	Bit [1:0]	Output Sinking Current	Note
11	2mA	For GPIO	11	-2mA	For GPIO
10	1mA	For GPIO	10	-1mA	For GPIO
01	6mA		01	-6mA	
00	4mA		00	-4mA	

(35) Enable SO to Output RY/BY# (ESRY)

The ESRY instruction is for outputting the ready/busy status to SO during CP mode.
The sequence of issuing ESRY instruction is: CS# goes low → sending ESRY instruction code → CS# goes high.
The CS# must go high exactly at the byte boundary; otherwise, the instruction will be rejected and not executed.

(36) Disable SO to Output RY/BY# (DSRY)

The DSRY instruction is for resetting ESRY during CP mode. The ready/busy status will not output to SO after DSRY issued.

The sequence of issuing DSRY instruction is: CS# goes low → send DSRY instruction code → CS# goes high.
The CS# must go high exactly at the byte boundary; otherwise, the instruction will be rejected and not executed.

(37) Enter CFI Mode (ENCFI)

TBD

POWER-ON STATE

The device is at below states when power-up:

- Standby mode (please note it is not Deep Power-down mode)
- Write Enable Latch (WEL) bit is reset

The device must not be selected during power-up and power-down stage unless the VCC achieves below correct level:

- VCC minimum at power-up stage and then after a delay of tVSL
- GND at power-down

Please note that a pull-up resistor on CS# may ensure a safe and proper power-up/down level.

An internal Power-on Reset (POR) circuit may protect the device from data corruption and inadvertent data change during power up state.

For further protection on the device, if the VCC does not reach the VCC minimum level, the correct operation is not guaranteed. The read, write, erase, and program command should be sent after the below time delay:

- tVSL after VCC reached VCC minimum level

The device can accept read command after VCC reached VCC minimum and a time delay of tVSL.

Please refer to the figure of "Power-up Timing".

Note:

- To stabilize the VCC level, the VCC rail decoupled by a suitable capacitor close to package pins is recommended. (generally around 0.1uF)

ELECTRICAL SPECIFICATIONS

ABSOLUTE MAXIMUM RATINGS

RATING		VALUE
Ambient Operating Temperature	Industrial grade	-40°C to 85°C
Storage Temperature		-55°C to 125°C
Applied Input Voltage		-0.5V to 4.6V
Applied Output Voltage		-0.5V to 4.6V
VCC to Ground Potential		-0.5V to 4.6V

NOTICE:

1. Stresses greater than those listed under ABSOLUTE MAXIMUM RATINGS may cause permanent damage to the device. This is stress rating only and functional operational sections of this specification is not implied. Exposure to absolute maximum rating conditions for extended period may affect reliability.
2. Specifications contained within the following tables are subject to change.
3. During voltage transitions, all pins may overshoot Vss to -2.0V and Vcc to +2.0V for periods up to 20ns, see Figure 2, 3.

Figure 2. Maximum Negative Overshoot Waveform

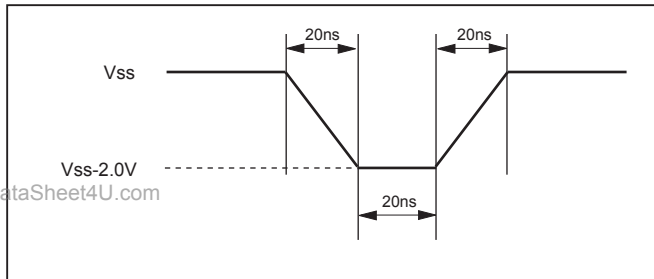
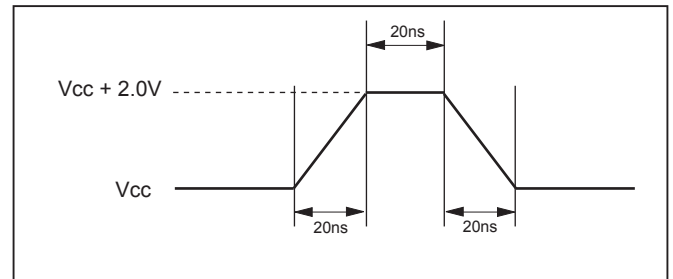

Figure 3. Maximum Positive Overshoot Waveform



CAPACITANCE TA = 25°C, f = 1.0 MHz

SYMBOL	PARAMETER	MIN.	TYP	MAX.	UNIT	CONDITIONS
CIN	Input Capacitance			6	pF	VIN = 0V
COU	Output Capacitance			8	pF	VOU = 0V

Figure 4. INPUT TEST WAVEFORMS AND MEASUREMENT LEVEL

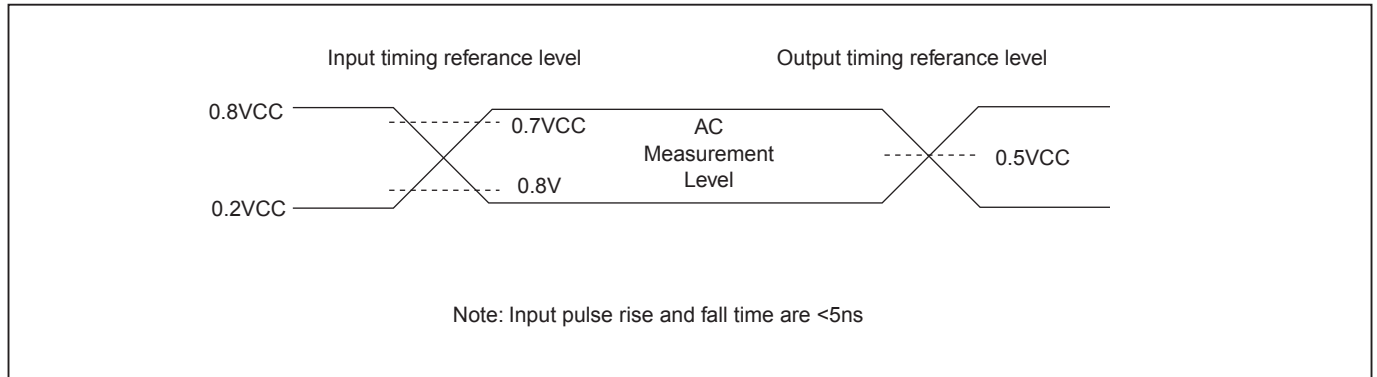
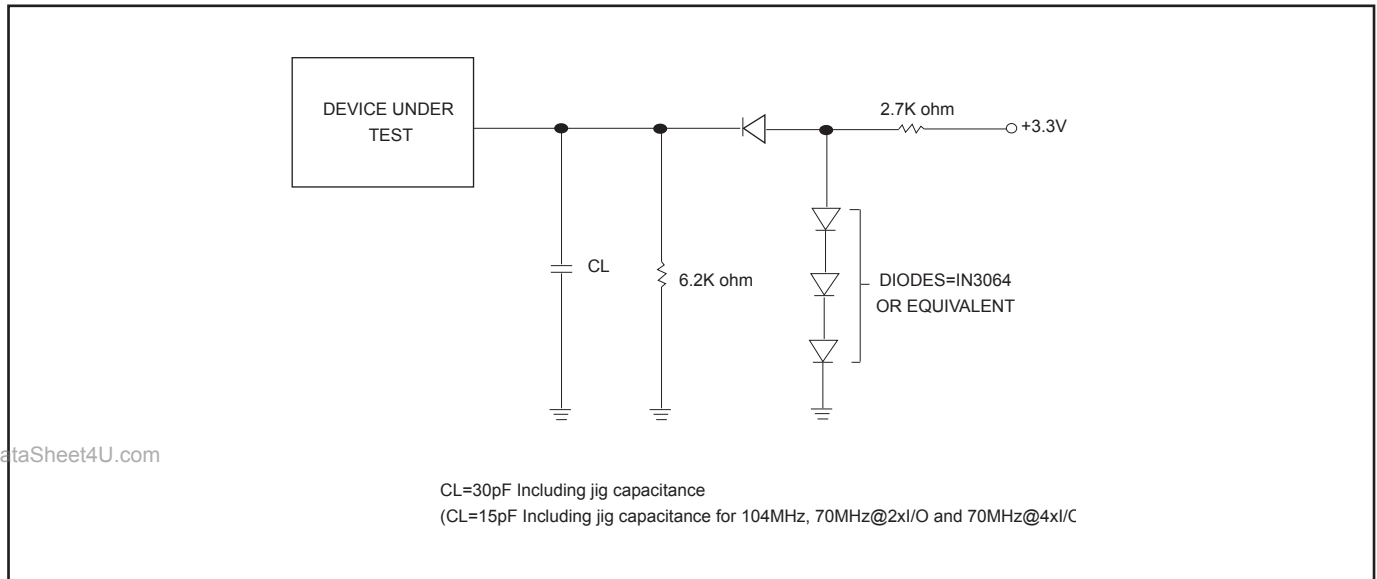

Figure 5. OUTPUT LOADING



www.DataSheet4U.com

Table 7. DC CHARACTERISTICS (Temperature = -40°C to 85°C for Industrial grade, VCC = 2.7V ~ 3.6V)

SYMBOL	PARAMETER	NOTES	MIN.	MAX.	UNITS	TEST CONDITIONS
ILI	Input Load Current	1		± 2	uA	VCC = VCC Max, VIN = VCC or GND
ILO	Output Leakage Current	1		± 2	uA	VCC = VCC Max, VIN = VCC or GND
ISB1	VCC Standby Current	1		100	uA	VIN = VCC or GND, CS# = VCC
ISB2	Deep Power-down Current			40	uA	VIN = VCC or GND, CS# = VCC
ICC1	VCC Read	1		45	mA	f=104MHz, fQ=75MHz (2 x I/O read) SCLK=0.1VCC/0.9VCC, SO=Open
				40	mA	f=66MHz, fT=75MHz (4 x I/O read) SCLK=0.1VCC/0.9VCC, SO=Open
				30	mA	f=33MHz, SCLK=0.1VCC/0.9VCC, SO=Open
ICC2	VCC Program Current (PP)	1		25	mA	Program in Progress, CS# = VCC
ICC3	VCC Write Status Register (WRSR) Current			20	mA	Program status register in progress, CS#=VCC
ICC4	VCC Sector Erase Current (SE)	1		25	mA	Erase in Progress, CS#=VCC
ICC5	VCC Chip Erase Current (CE)	1		20	mA	Erase in Progress, CS#=VCC
VIL	Input Low Voltage		-0.5	0.8	V	
VIH	Input High Voltage		0.7VCC	VCC+0.4	V	
VOL	Output Low Voltage			0.4	V	IOL = 1.6mA; IOL=140uA for Parallel mode
VOH	Output High Voltage		VCC-0.2		V	IOH = -100uA; IOH=65uA for Parallel mode

Notes :

1. Typical values at VCC = 3.3V, T = 25°C. These currents are valid for all product versions (package and speeds).
2. Typical value is calculated by simulation.

Table 8. AC CHARACTERISTICS (Temperature = -40°C to 85°C for Industrial grade, VCC = 2.7V ~ 3.6V)

Symbol	Alt.	Parameter	Min.	Max.	Unit	
fSCLK	fC	Clock Frequency for the following instructions: FAST_READ, PP, SE, BE, CE, DP, RES, RDP WREN, WRDI, RDID, RDSR, WRSR	Serial	D.C.	104 (Condition:15pF)	MHz
			Parallel/GPIO	D.C.	66 (Condition:30pF)	MHz
					6	MHz
fRSCLK	fR	Clock Frequency for READ instructions		50	MHz	
fTSCLK	fT	Clock Frequency for 2READ instructions		70	MHz	
	fQ	Clock Frequency for 4READ instructions		70 (Condition:15pF)	MHz	
	fC2	Clock Frequency for FASTDTRRD instructions		50	MHz	
	fT2	Clock Frequency for 2DTRRD instructions		50	MHz	
	fQ2	Clock Frequency for 4DTRRD instructions		50	MHz	
f4PP		Clock Frequency for 4PP (Quad page program)		20	MHz	
tCH(1)	tCLH	Clock High Time	Serial	5.5	ns	
			Parallel/GPIO	30	ns	
tCL(1)	tCLL	Clock Low Time	Serial	5.5	ns	
			Parallel/GPIO	30	ns	
tCLCH(2)		Clock Rise Time (3) (peak to peak)	Serial	0.1	V/ns	
			Parallel/GPIO	0.25	V/ns	
tCHCL(2)		Clock Fall Time (3) (peak to peak)	Serial	0.1	V/ns	
			Parallel/GPIO	0.25	V/ns	
tSLCH	tCSS	CS# Active Setup Time (relative to SCLK)	8		ns	
tCHSL		CS# Not Active Hold Time (relative to SCLK)	5		ns	
tDVCH	tDSU	Data In Setup Time	Serial	2	ns	
			Parallel	10	ns	
tCHDX	tDH	Data In Hold Time	Serial	5	ns	
			Parallel	10	ns	
tCHSH		CS# Active Hold Time (relative to SCLK)	Serial	5	ns	
			Parallel/GPIO	30	ns	
tSHCH		CS# Not Active Setup Time (relative to SCLK)	8		ns	
tSHSL(3)	tCSH	CS# Deselect Time	Read	15	ns	
			Write/Erase/ Program	50	ns	
tSHQZ(2)	tDIS	Output Disable Time	2.7V-3.6V Serial	10	ns	
			3.0V-3.6V Serial	8	ns	
			Parallel/GPIO	20	ns	
tCLQV	tV	Clock Low to Output Valid VCC=2.7V~3.6V	Loading: 15pF	1 I/O	9	ns
				2 I/O & 4 I/O	9.5	ns
			Loading: 30pF	2 I/O & 4 I/O	12	ns
				Parallel/GPIO	70	ns
tCLQV2	tV2	Clock Low to Output Valid (DTR mode) VCC=2.7V~3.6V, Loading: 15pF	1 I/O, 2 I/O & 4 I/O	9.5	ns	
tCLQX	tHO	Output Hold Time	2		ns	
tWHSL(4)		Write Protect Setup Time	20		ns	
tSHWL(4)		Write Protect Hold Time	100		ns	

Symbol	Alt.	Parameter	Min.	Typ.	Max.	Unit
tDP(2)		CS# High to Deep Power-down Mode			10	us
tRES1(2)		CS# High to Standby Mode without Electronic Signature Read			100	us
tRES2(2)		CS# High to Standby Mode with Electronic Signature Read			100	us
tW		Write Status Register Cycle Time		40	100	ms
tBP		Byte-Program		9	300	us
tPP		Page Program Cycle Time		1.4	5	ms
tSE		Sector Erase Cycle Time (4KB)		90	300	ms
tBE		Block Erase Cycle Time (64KB)		0.7	2	s
tBE		Block Erase Cycle Time (32KB)		0.5	2	s
tCE		Chip Erase Cycle Time		80	512	s
tRESE	tr	GPIO [6:0] 20%~80% at 3V	70			ns
tFALL	tf	GPIO [6:0] 20%~80% at 3V	90			ns
tLEAD		GPIO enable lead time (CS# Low to SCLK High)			60	ns
tLAG		GPIO enable lag time (SCLK Low to CS# High)			60	ns
tPL		Permanent Lock Time			1	ms
tWRLR		Write Read Lock Register Time			100	ms
tWPS		Write Protection Selection Time			1	ms
tWSR		Write Security Register Time			1	ms

Notes:

1. tCH + tCL must be greater than or equal to 1/ fC.
2. Value guaranteed by characterization, not 100% tested in production.
3. tSHSL=15ns from read instruction, tSHSL=50ns from Write/Erase/Program instruction.
4. Only applicable as a constraint for a WRSR instruction when SRWD is set at 1.
5. Test condition is shown as Figure 4, 5.
6. Only valid in output phase delay configuration "00".

Timing Analysis

Figure 6. Serial Input Timing

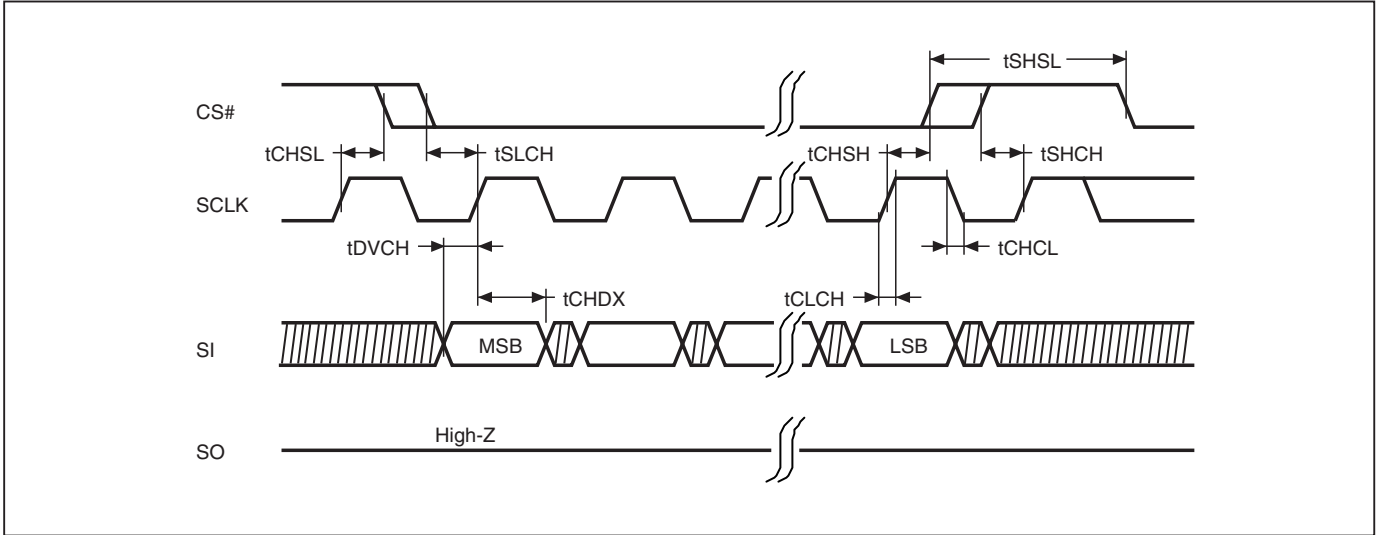

Figure 7. Output Timing

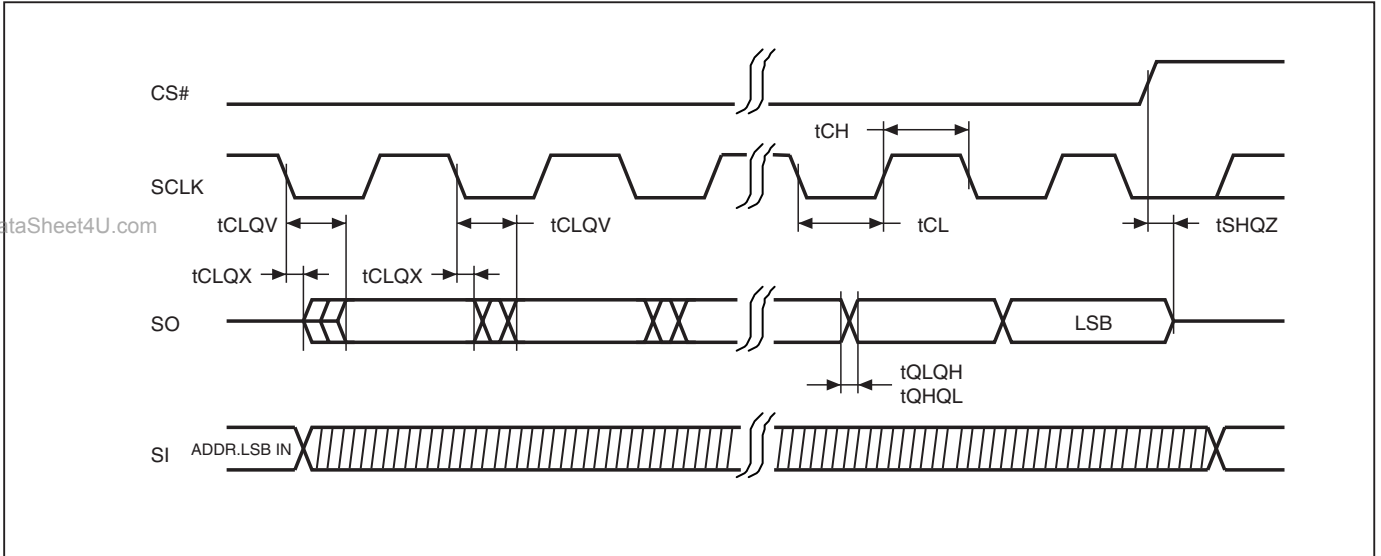

Figure 8. Serial Input Timing for Double Transfer Rate Mode

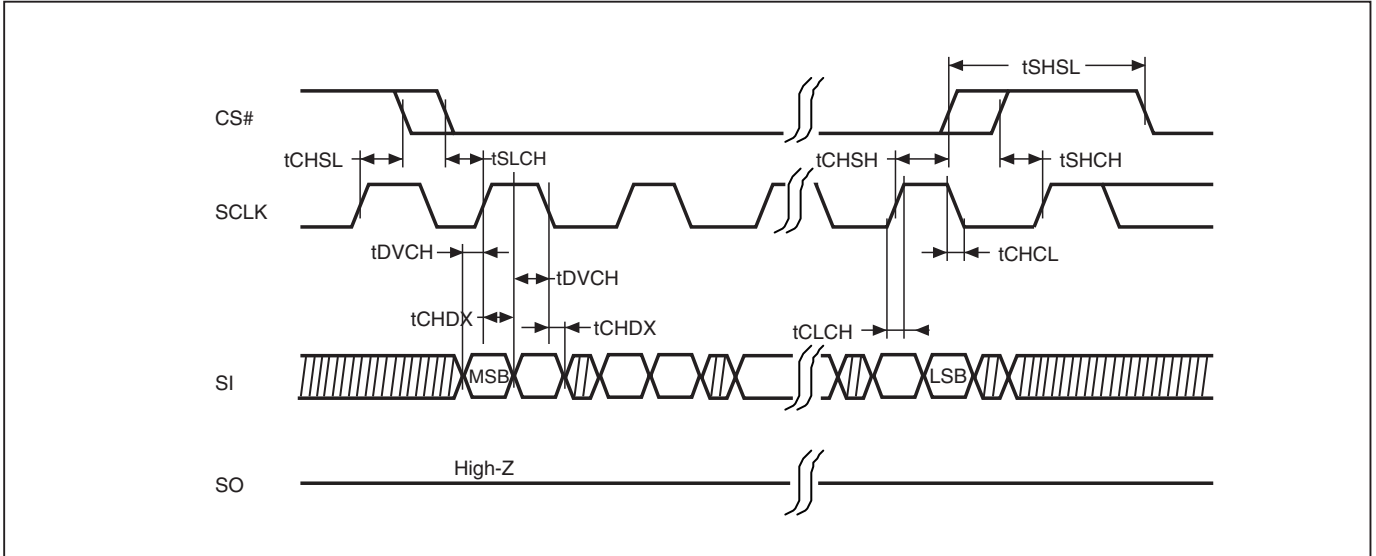

Figure 9. Serial Output Timing for Double Transfer Rate Mode

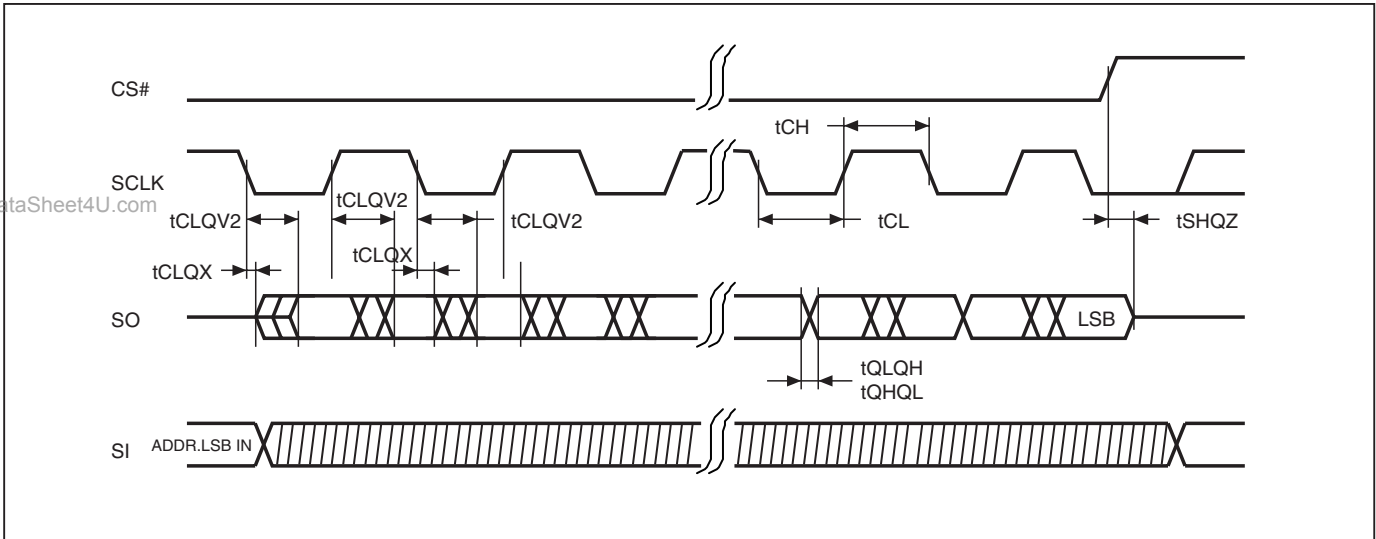

Figure 10. WP# Setup Timing and Hold Timing during WRSR when SRWD=1

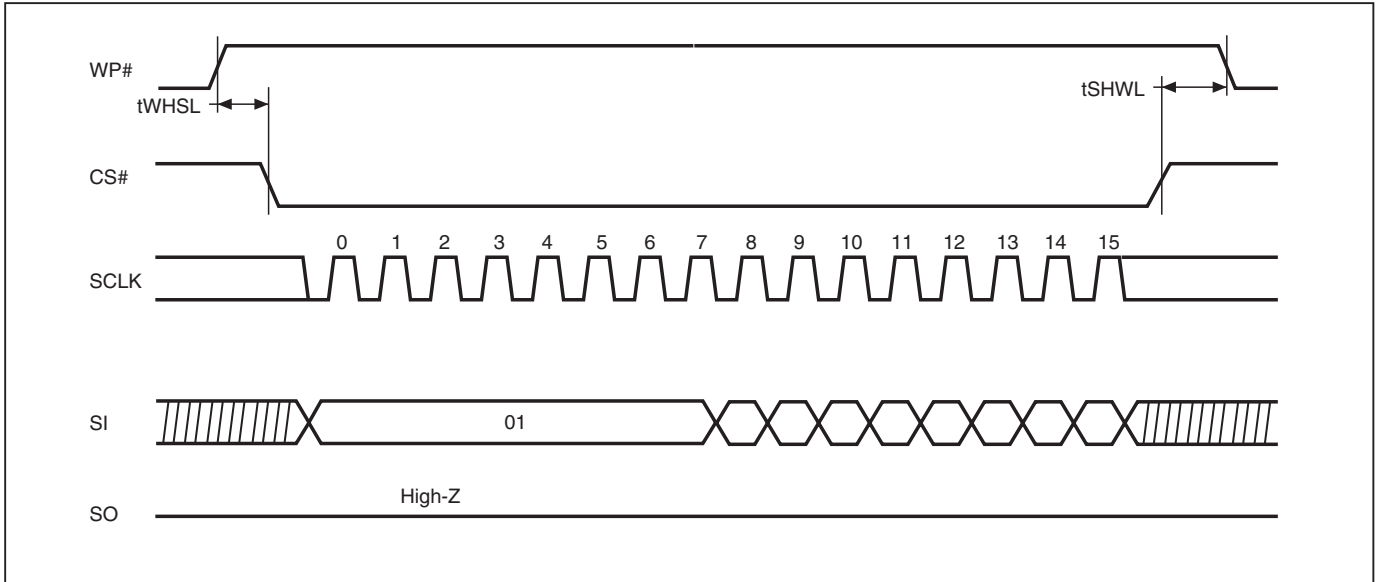

Figure 11. Write Enable (WREN) Sequence (Command 06)

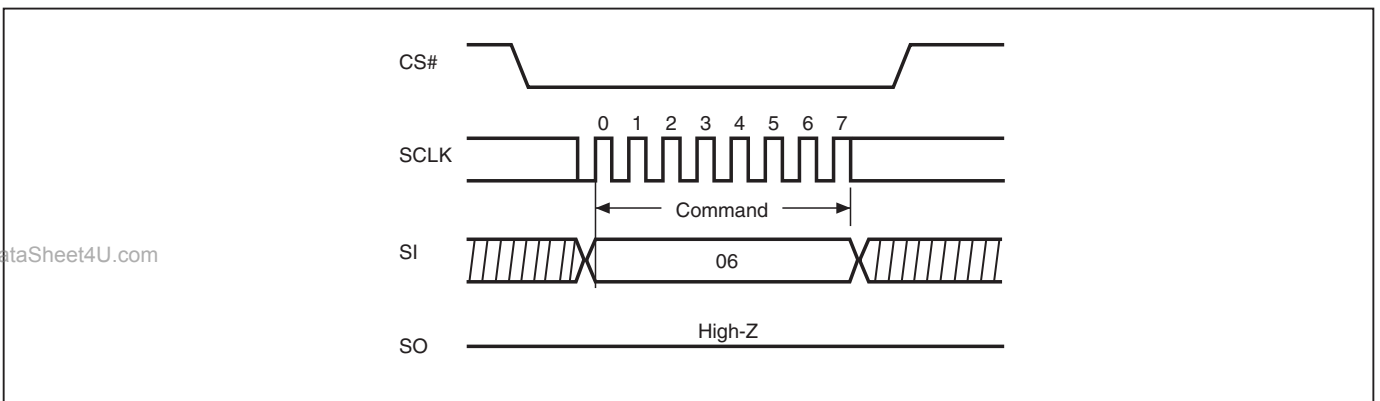

Figure 12. Write Disable (WRDI) Sequence (Command 04)

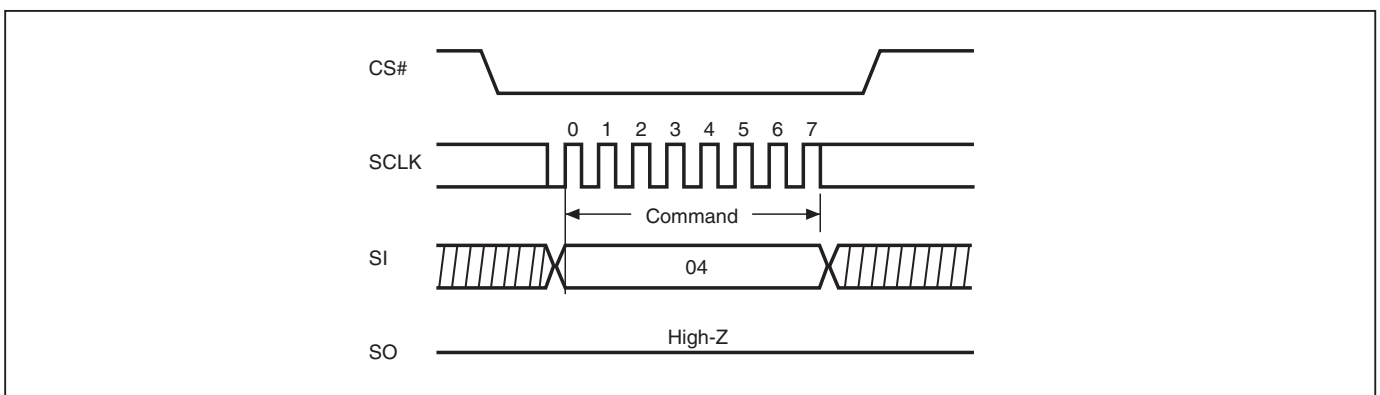

Figure 13. Read Identification (RDID) Sequence (Command 9F)

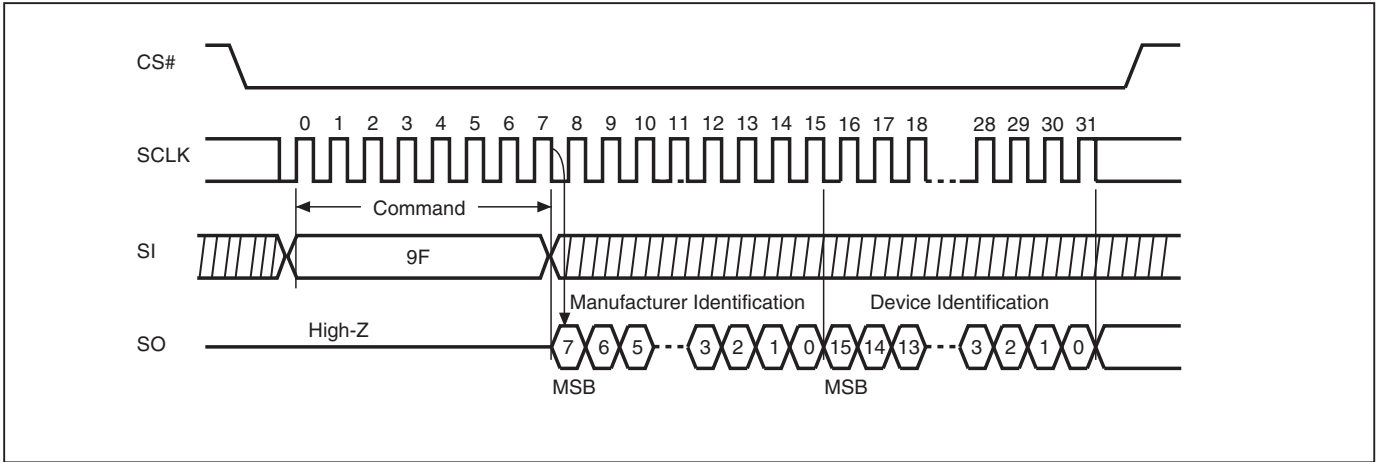
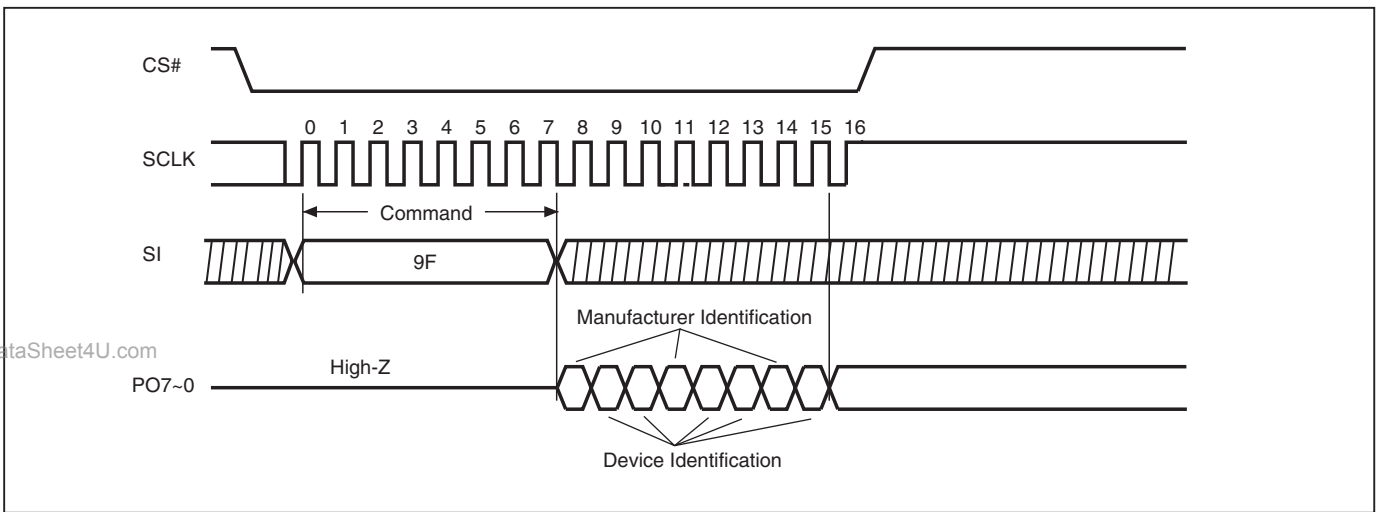

Figure 14. Read Identification (RDID) Sequence (Parallel)



Notes :

- Under parallel mode, the fastest access clock freq. will be changed to 6MHz(SCLK pin clock freq.)
To read identification in parallel mode, which requires a parallel mode command (55h) before the read identification command. To exit parallel mode, it requires a (45h) command or power-off/on sequence.
- There are 3 data bytes which would be output sequentially for Manufacturer and Device ID 1'st byte (Memory Type) and Device ID 2'nd byte (Memory Density).

Figure 15. Read Status Register (RDSR) Sequence (Command 05)

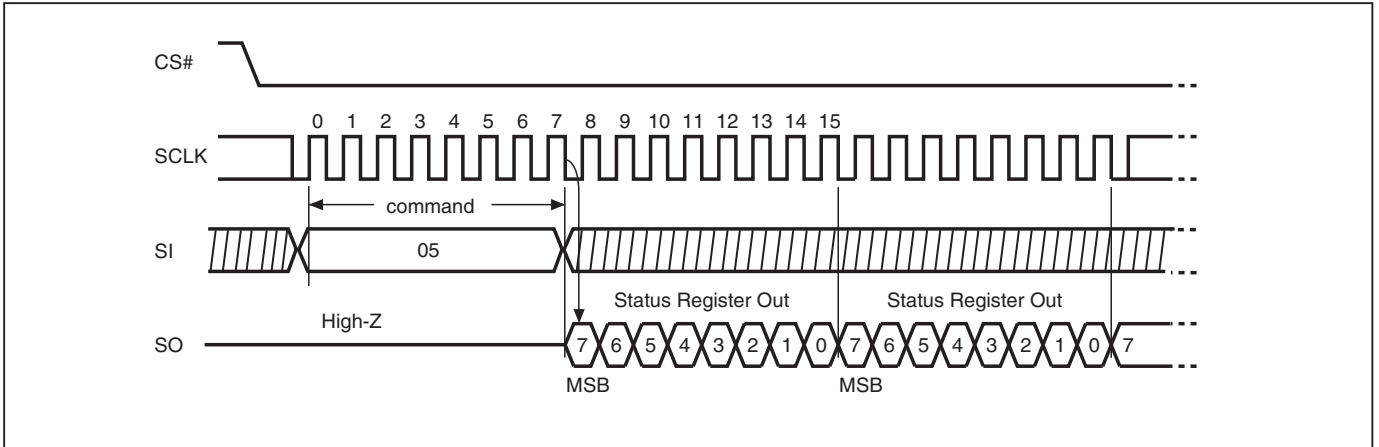
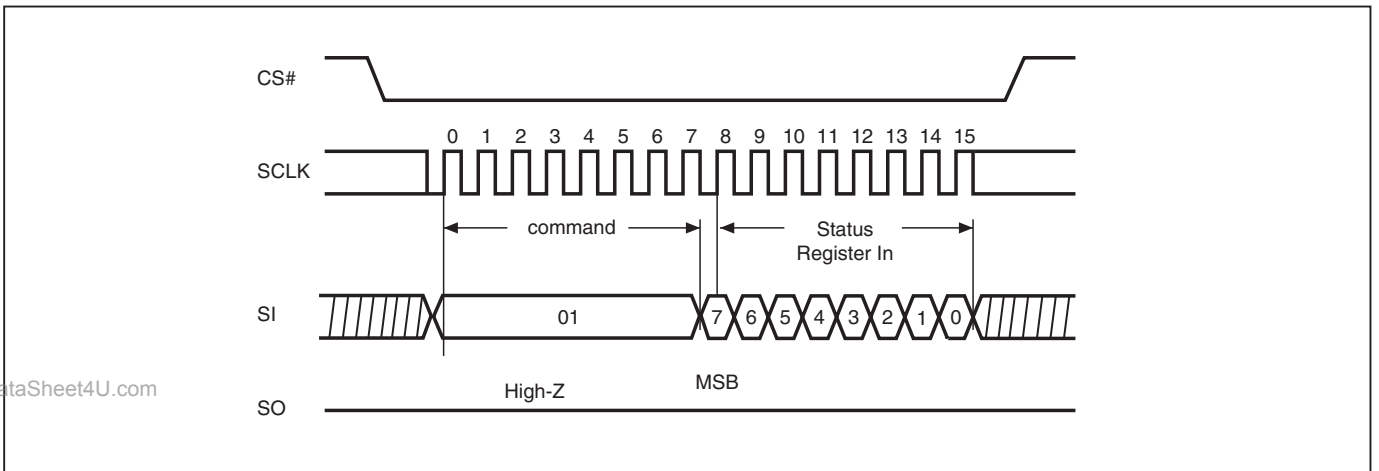

Figure 16. Write Status Register (WRSR) Sequence (Command 01)



www.DataSheet4U.com

Figure 17. Read Data Bytes (READ) Sequence (Command 03)

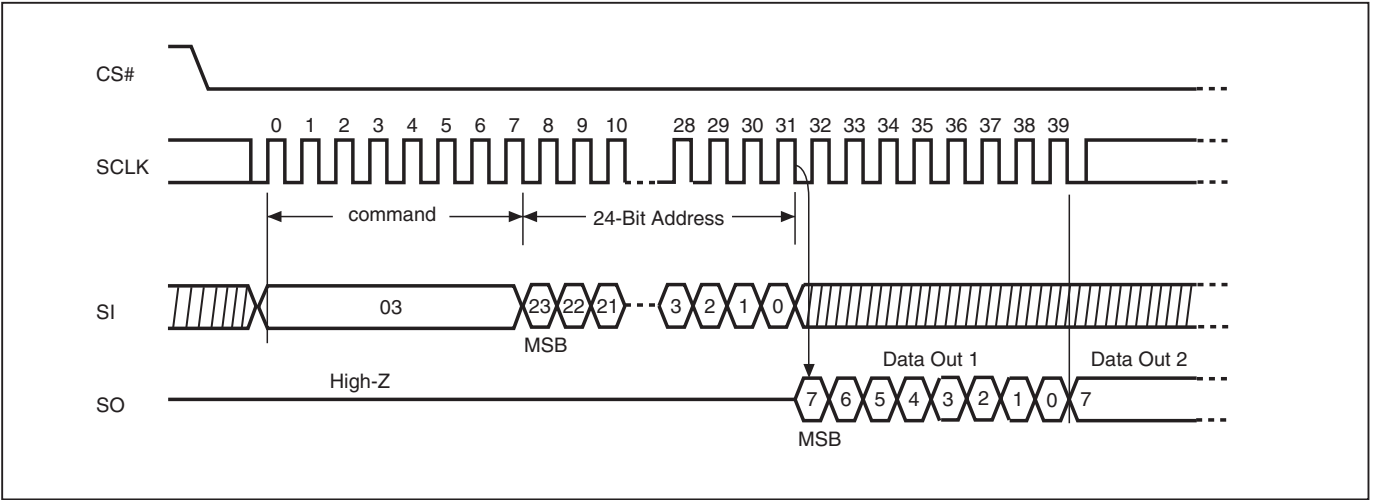
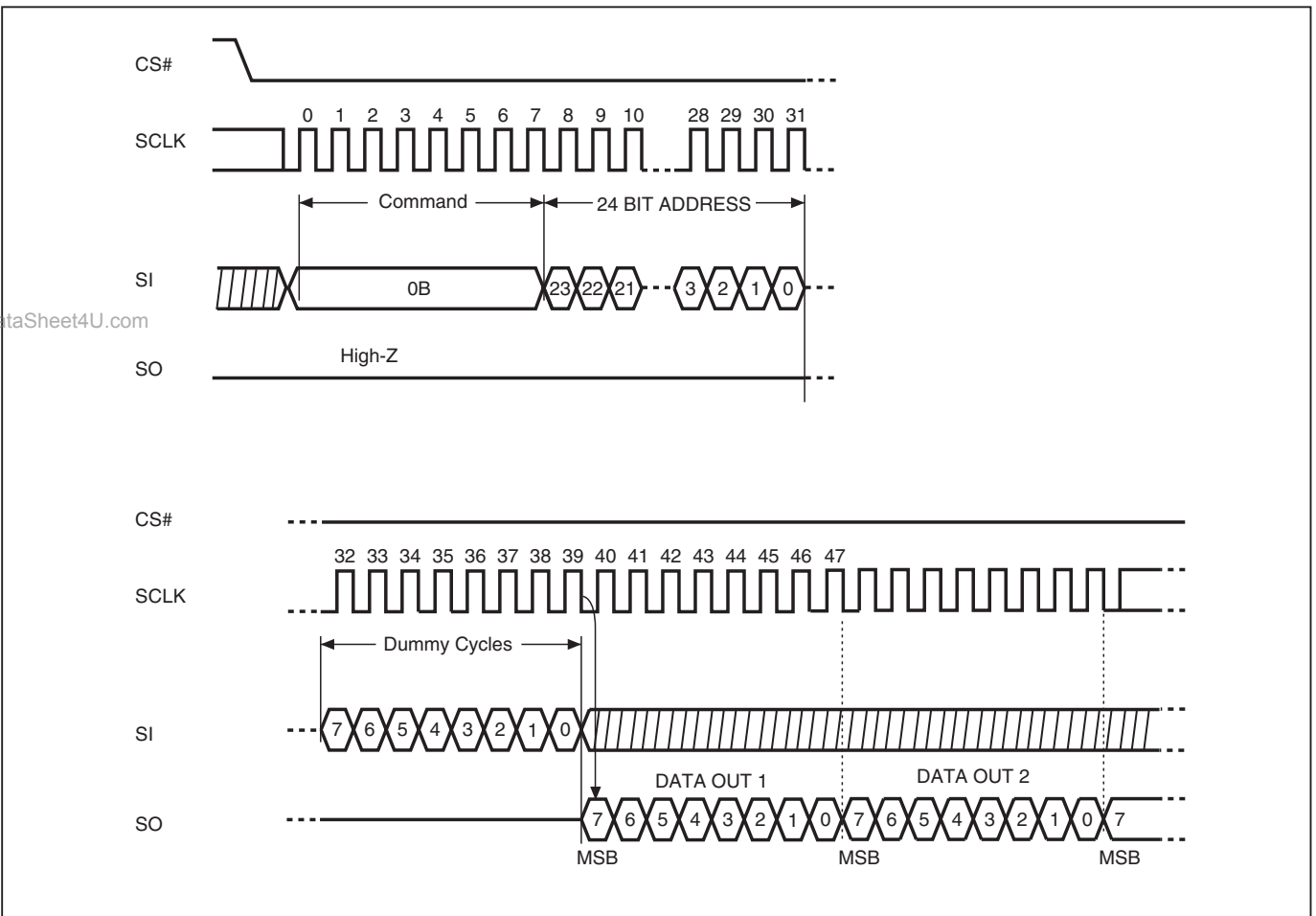

Figure 18. Read at Higher Speed (FAST_READ) Sequence (Command 0B)



www.DataSheet4U.com

Figure 19. Fast DT Read (FASTDTRD) Sequence (Command 0D)

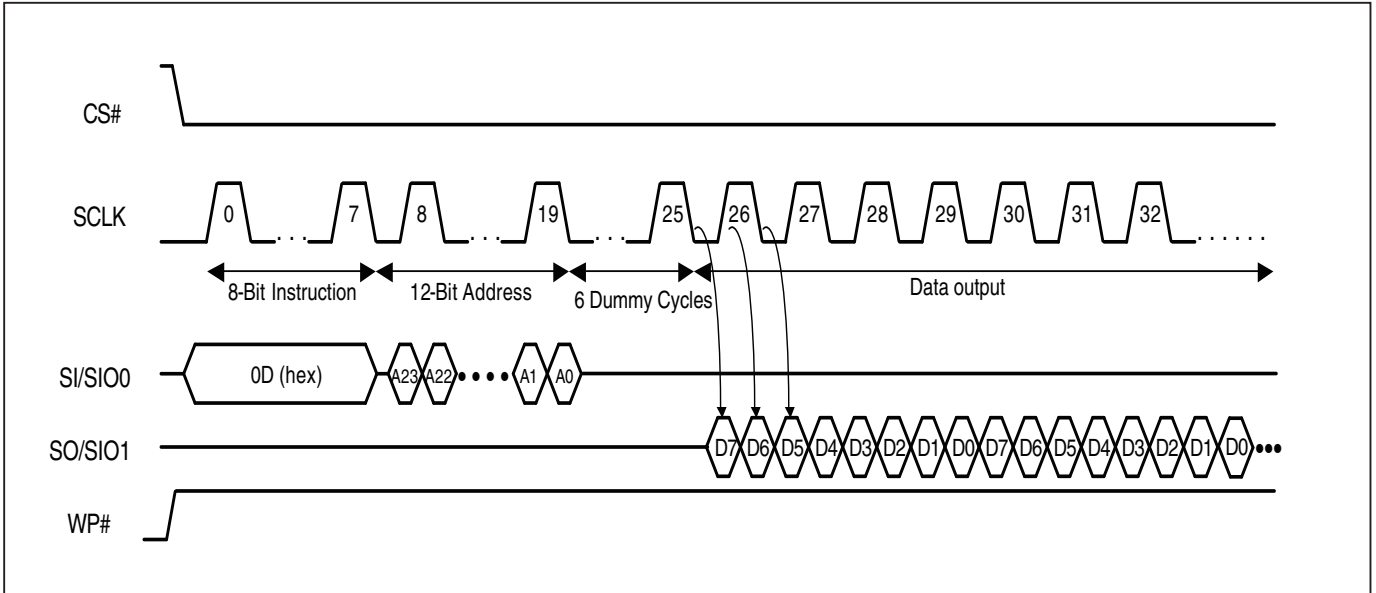

Figure 20. 2 x I/O Read Mode Sequence (Command BB)

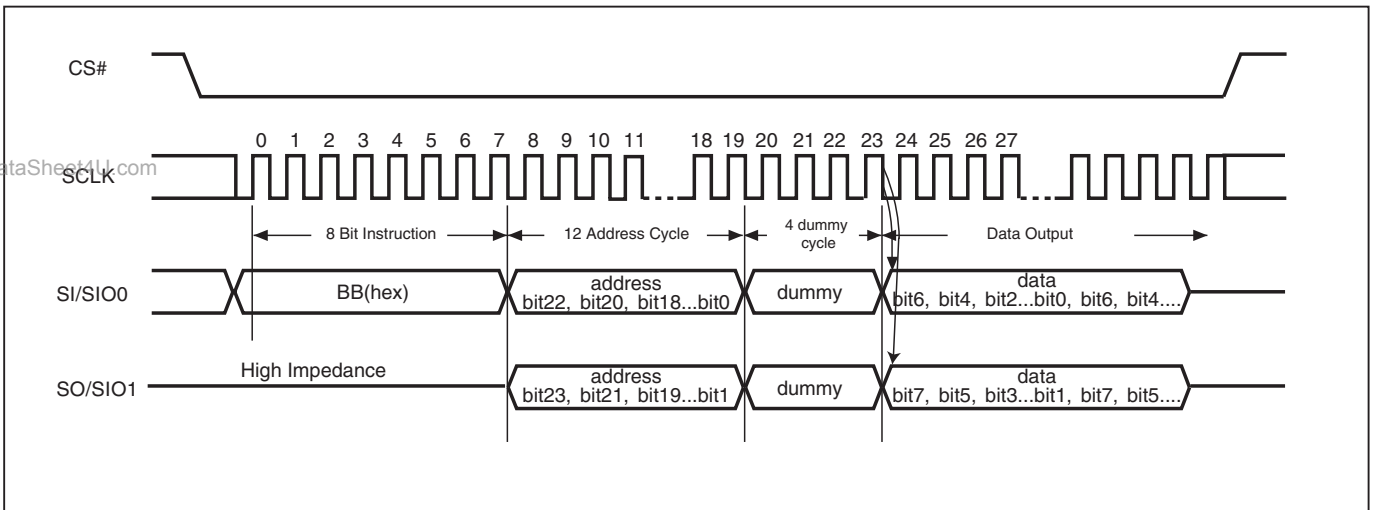

Figure 21. Fast Dual I/O DT Read (2DTRD) Sequence (Command BD)

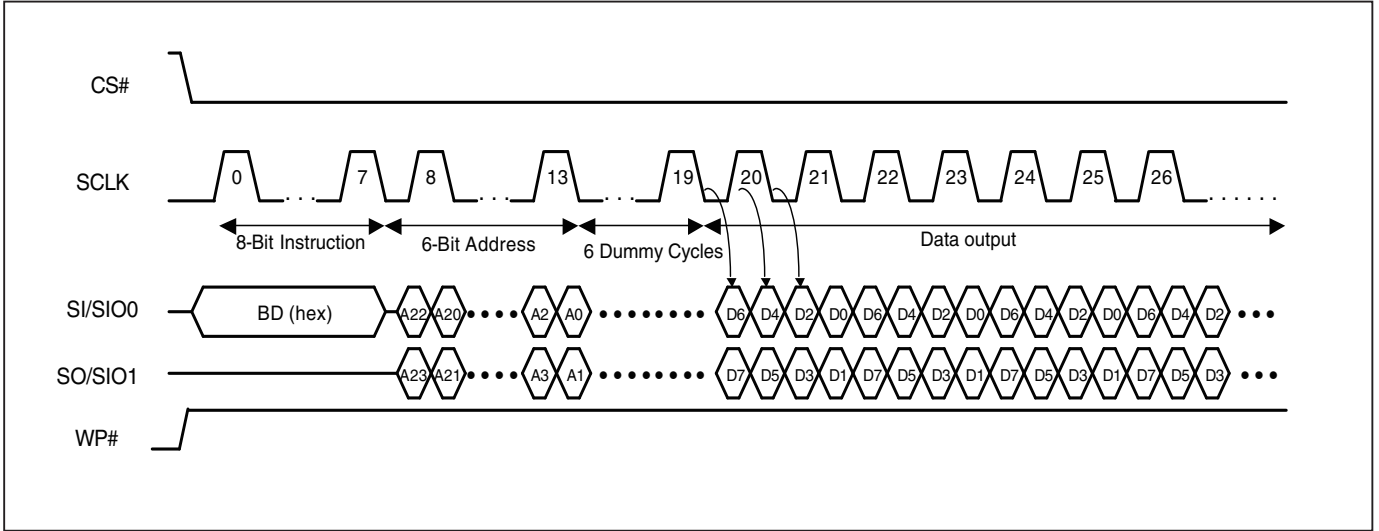
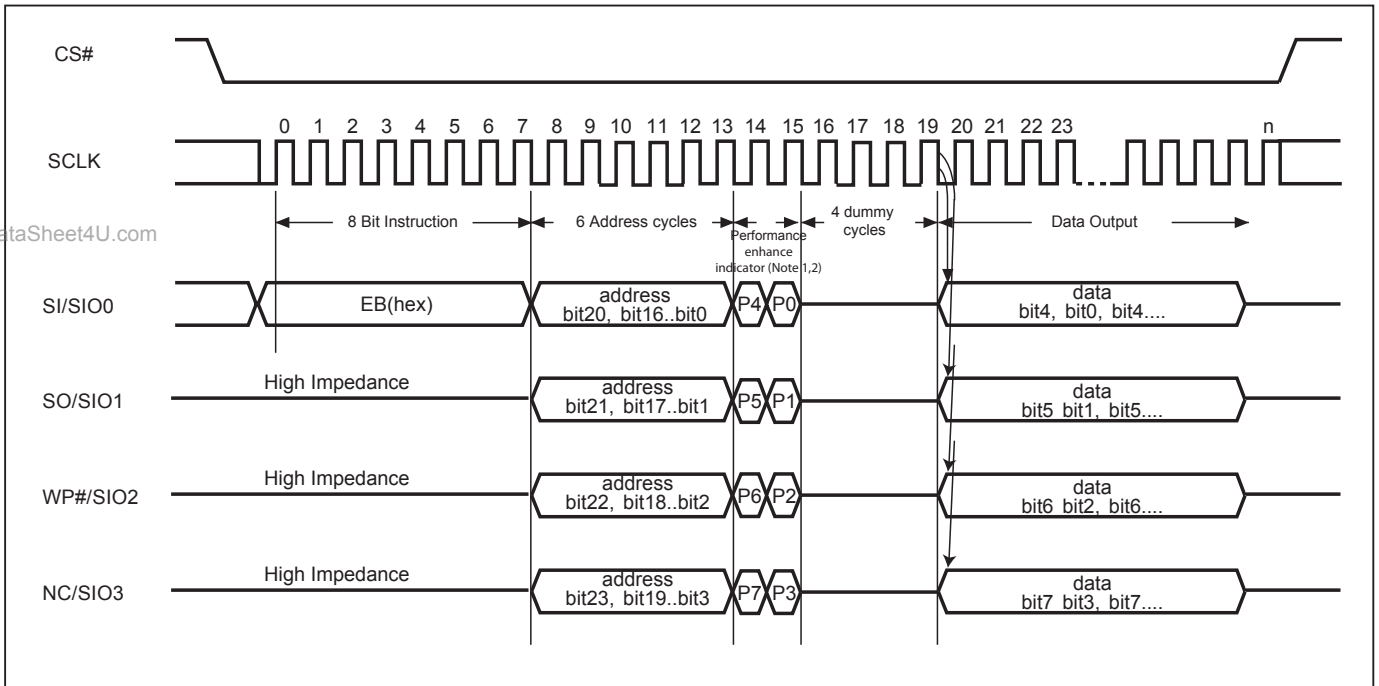

Figure 22. 4 x I/O Read Mode Sequence (Command EB)



Note:

1. Hi-impedance is inhibited for the two clock cycles.
2. P7≠P3, P6≠P2, P5≠P1 & P4≠P0 (Toggling) will enter the performance enhance mode.

Figure 23. 4 x I/O Read Enhance Performance Mode Sequence (Command EB)

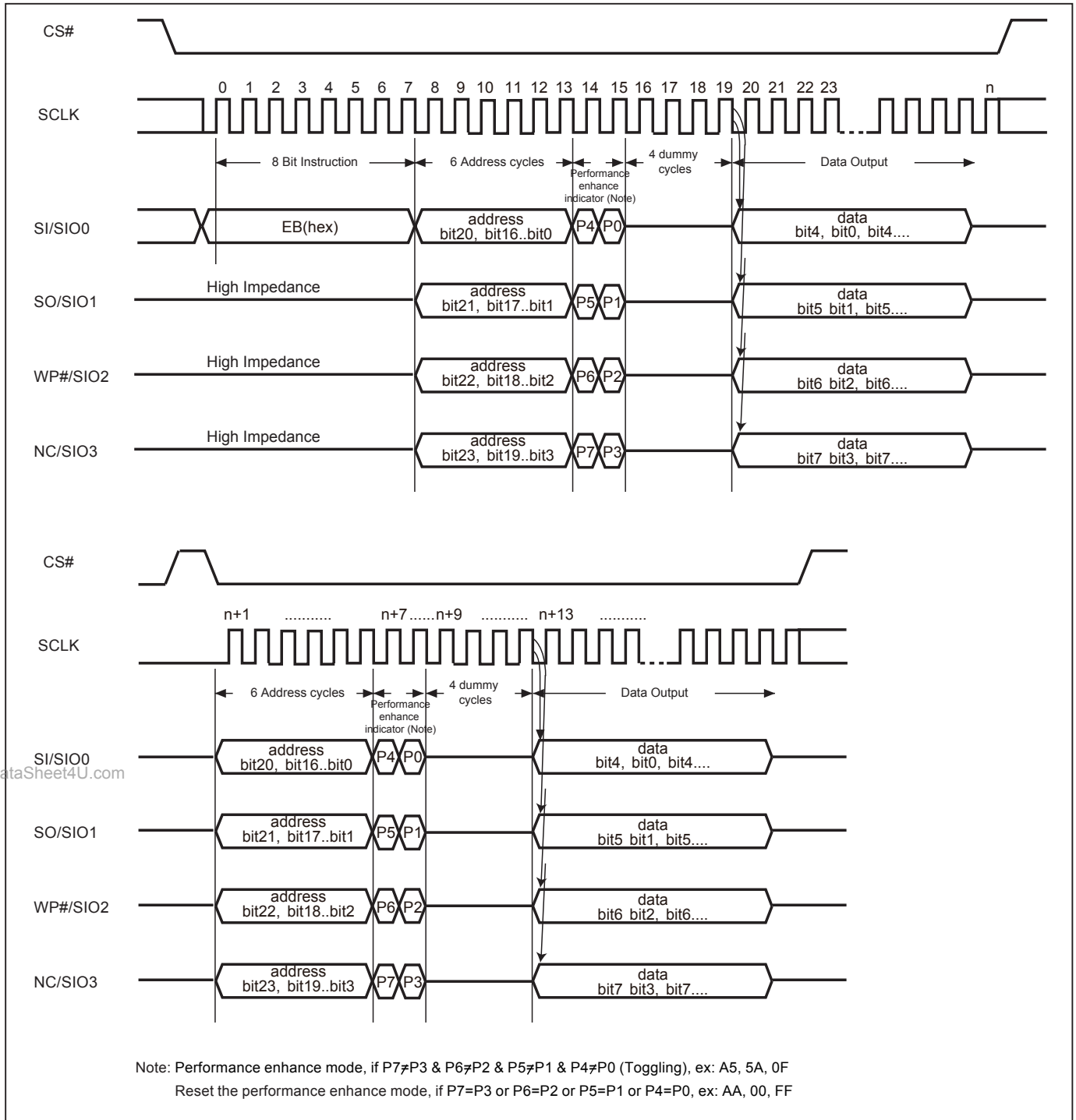
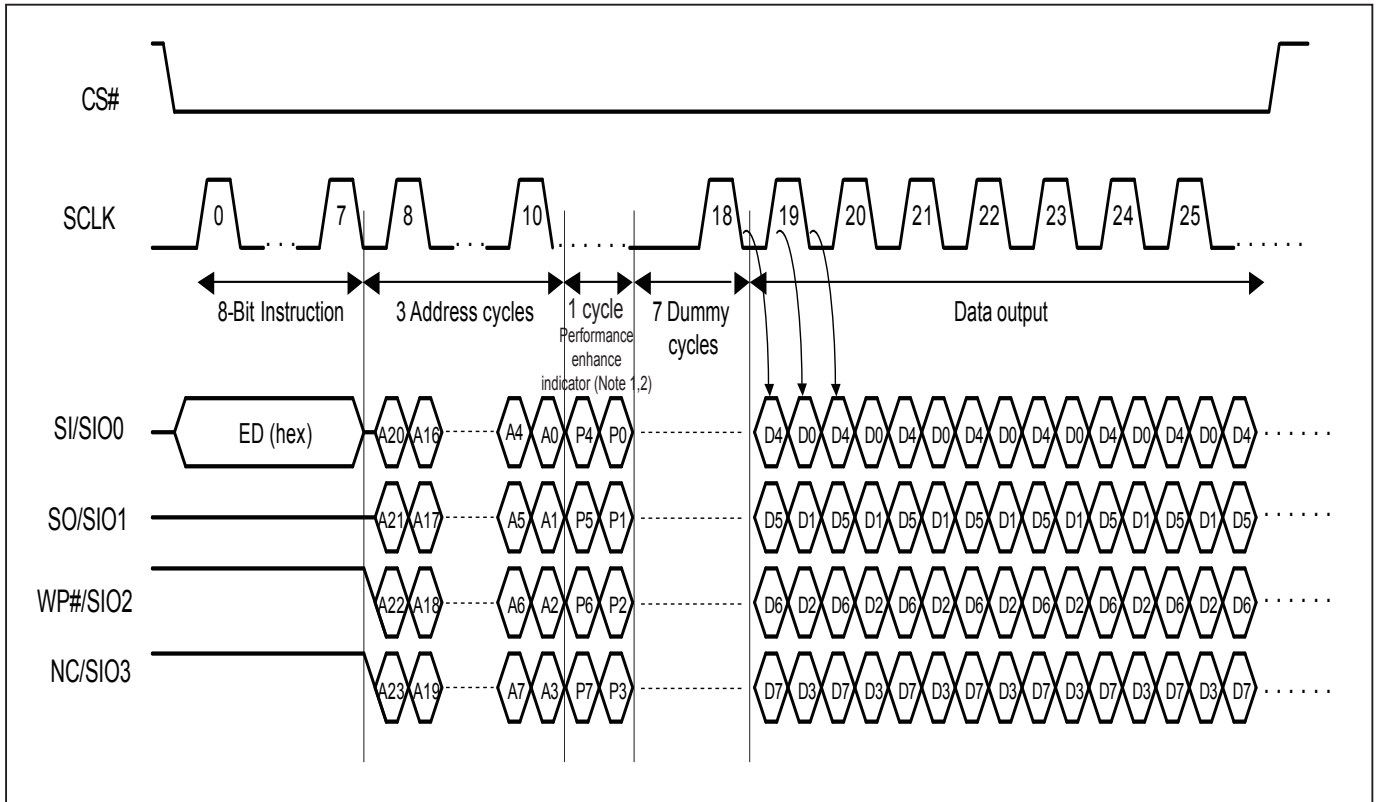

Figure 24. Fast Quad I/O DT Read (4DTRD) Sequence (Command ED)



Note:

1. Hi-impedance is inhibited for this clock cycle.
2. P7≠P3, P6≠P2, P5≠P1 & P4≠P0 (Toggling) will enter the performance enhance mode.

Figure 25. Fast Quad I/O DT Read (4DTRD) Enhance Performance Sequence (Command ED)

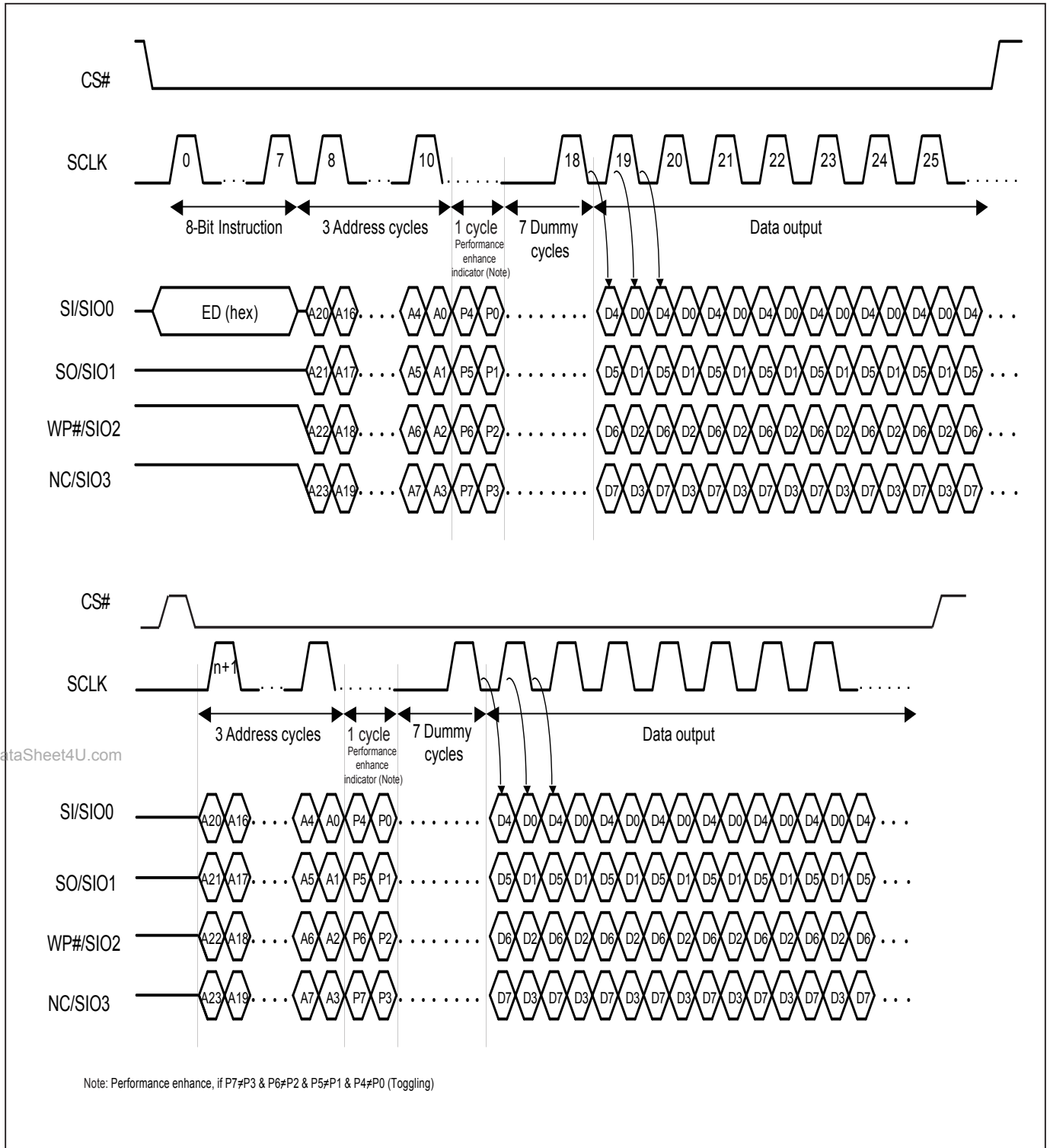

www.DataSheet4U.com

Figure 26. Page Program (PP) Sequence (Command 02)

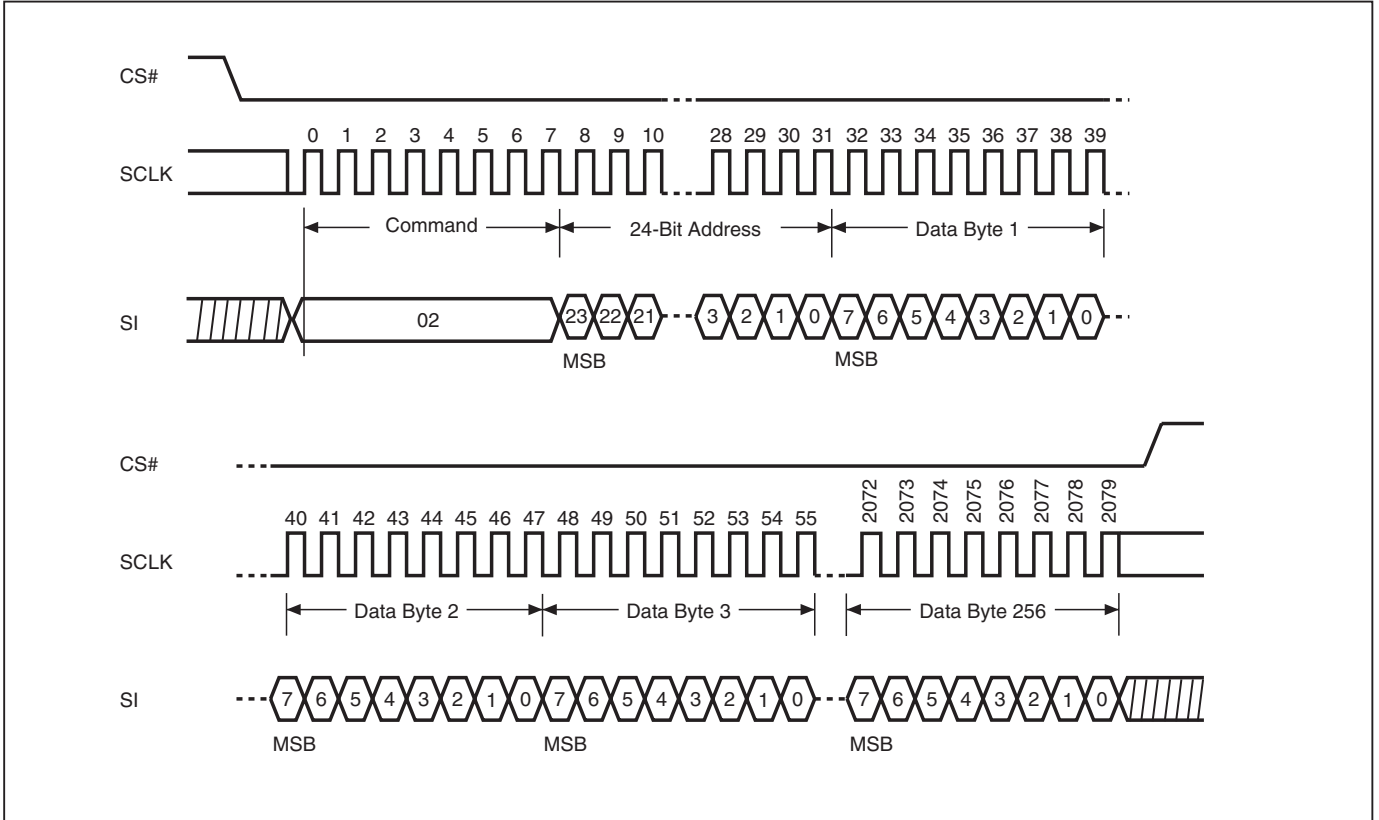

Figure 27. 4 x I/O Page Program (4PP) Sequence (Command 38)

www.DataSheet4U.com

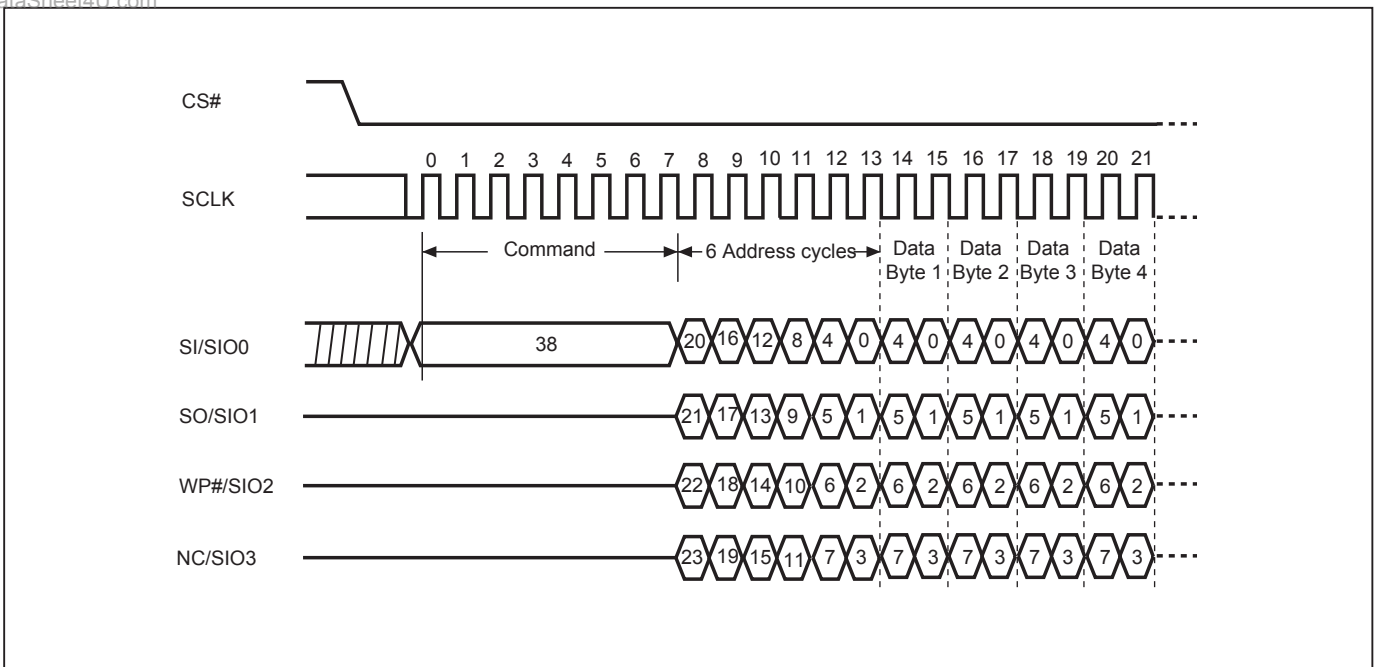
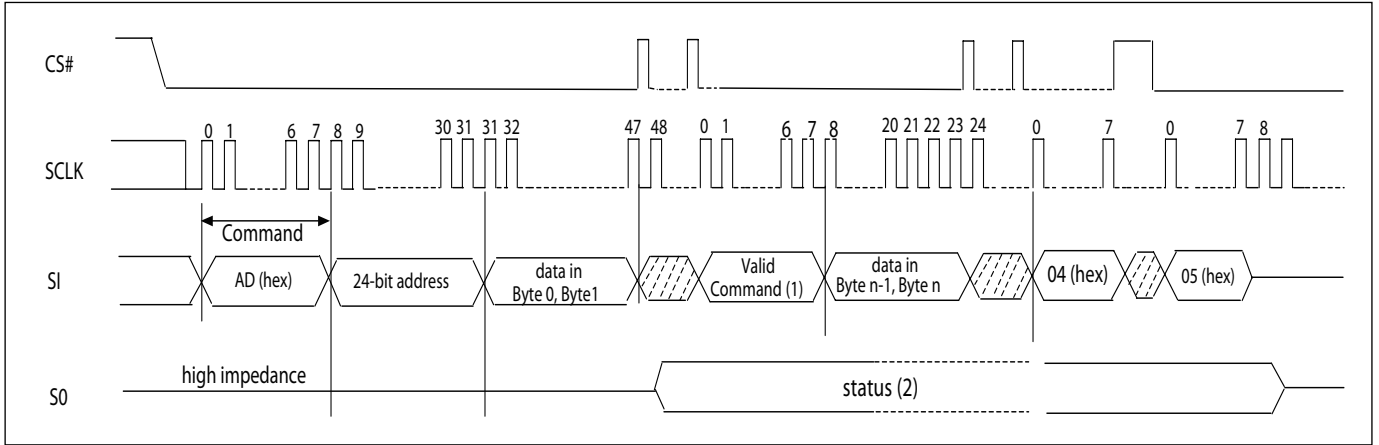
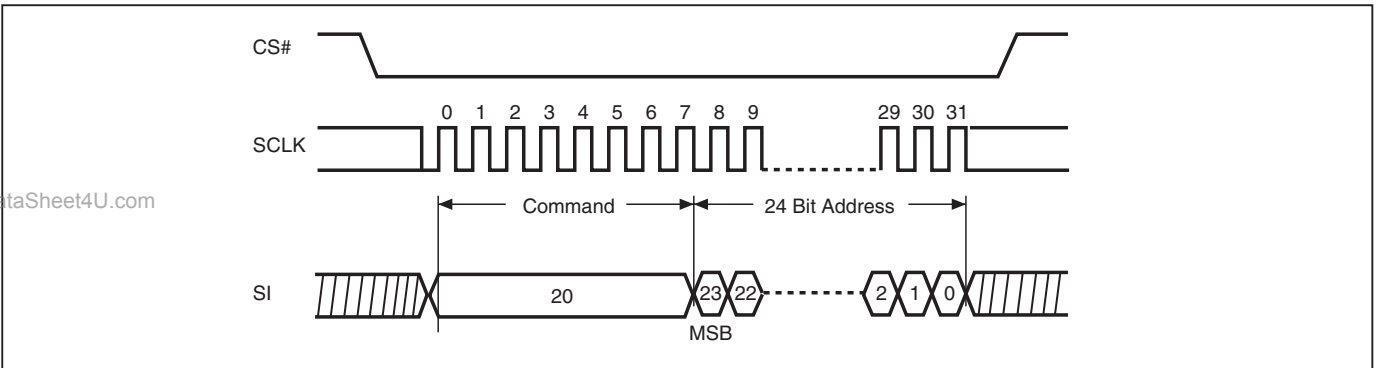

Figure 28. Continously Program (CP) Mode Sequence with Hardware Detection (Command AD)



- Note: (1) During CP mode, the valid commands are CP command (AD hex), WRDI command (04 hex), RDSR command (05 hex), and RDSCUR command (2B hex).
 (2) Once an internal programming operation begins, CS# goes low will drive the status on the SO pin and CS# goes high will return the SO pin to tri-state.
 (3) To end the CP mode, either reaching the highest unprotected address or sending Write Disable (WRDI) command (04 hex) may achieve it and then it is recommended to send RDSR command (05 hex) to verify if CP mode is ended.

Figure 29. Sector Erase (SE) Sequence (Command 20)



Note: SE command is 20(hex).

Figure 30. Block Erase (BE) Sequence (Command D8)

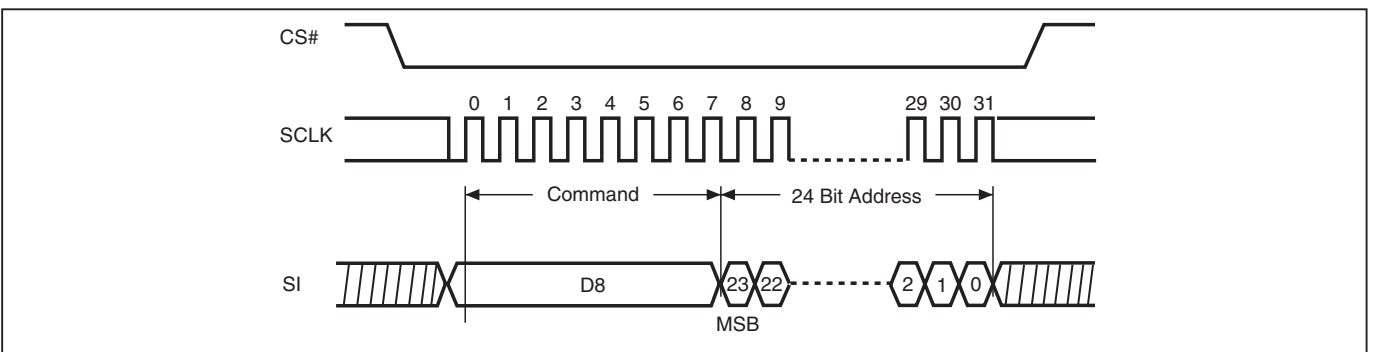

Note: BE command is D8(hex).

Figure 31. Chip Erase (CE) Sequence (Command 60 or C7)

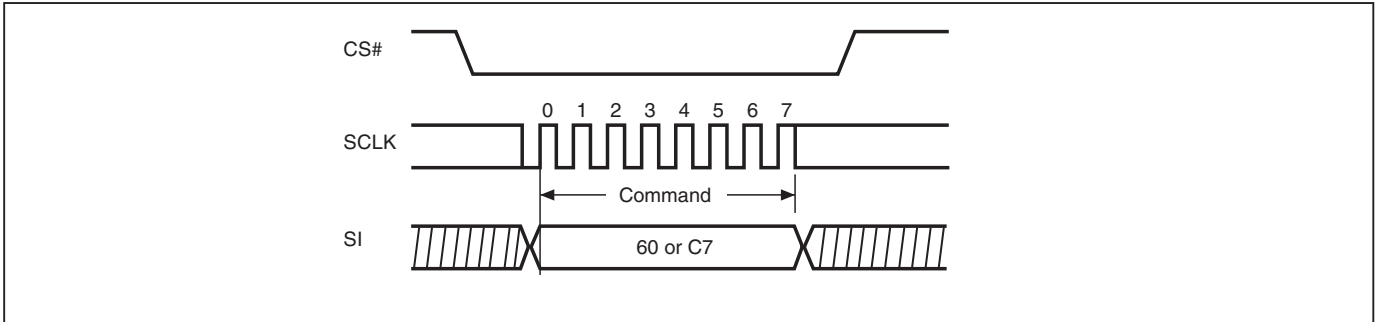

Note: CE command is 60(hex) or C7(hex).

Figure 32. Deep Power-down (DP) Sequence (Command B9)

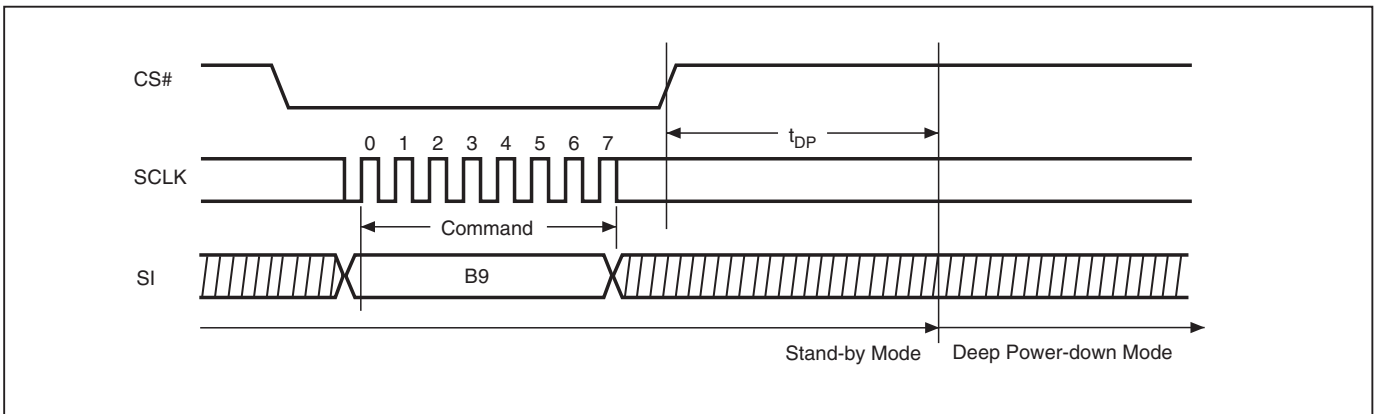

www.DataSheet4U.com

Figure 33. Release from Deep Power-down and Read Electronic Signature (RES) Sequence (Command AB)

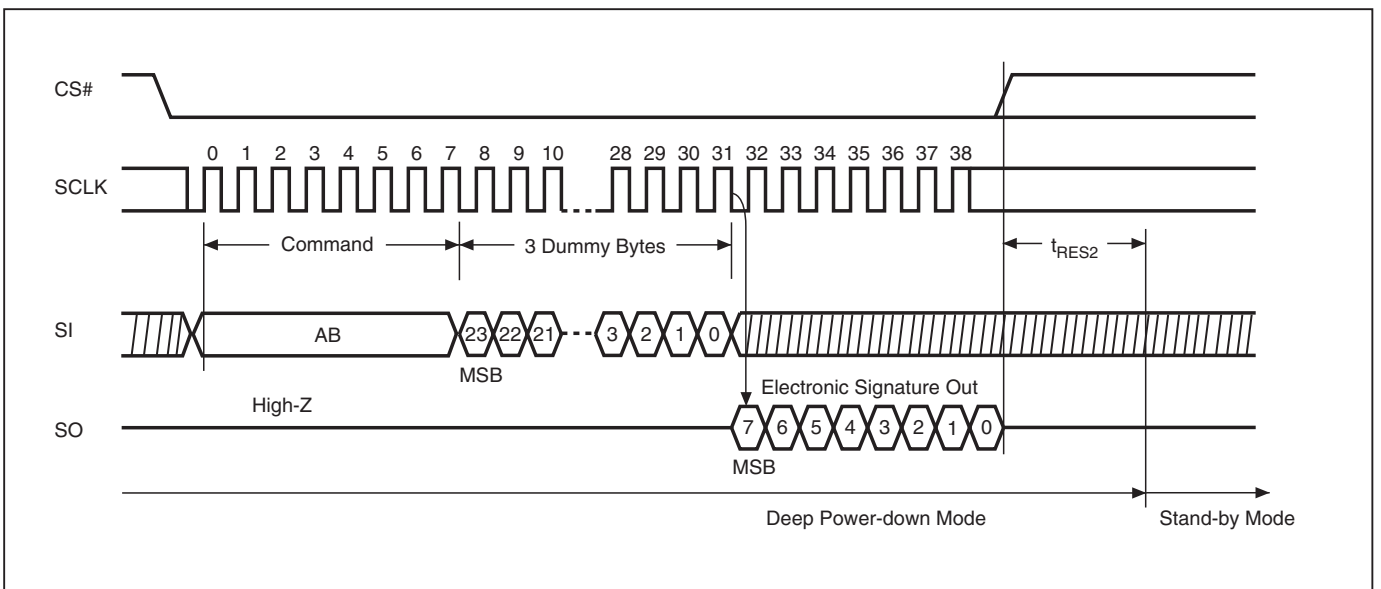

Figure 34. Release from Deep Power-down (RDP) Sequence (Command AB)

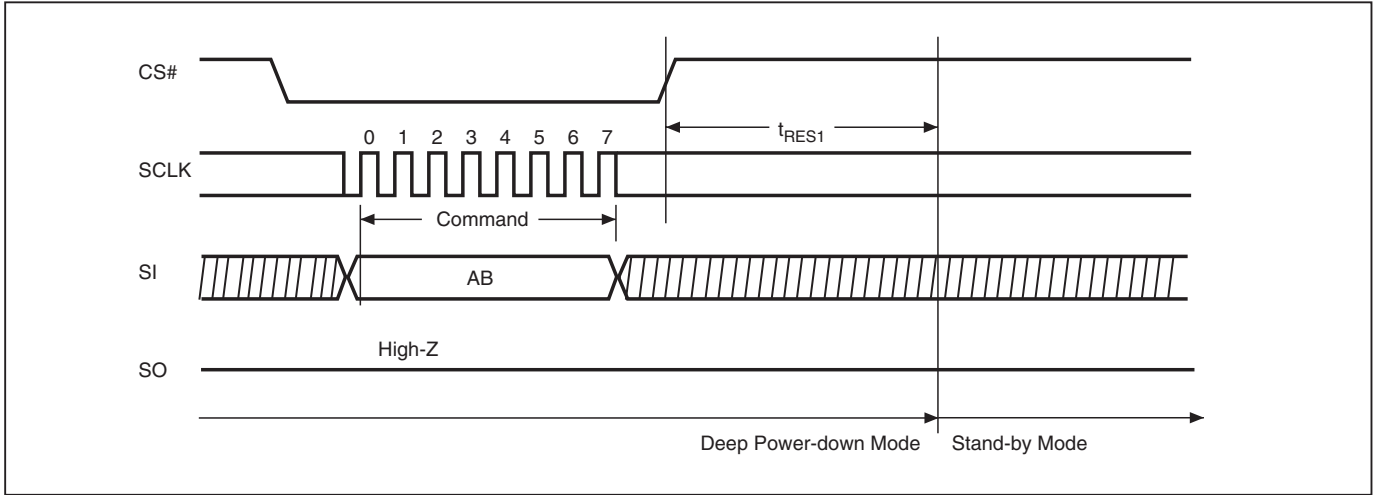
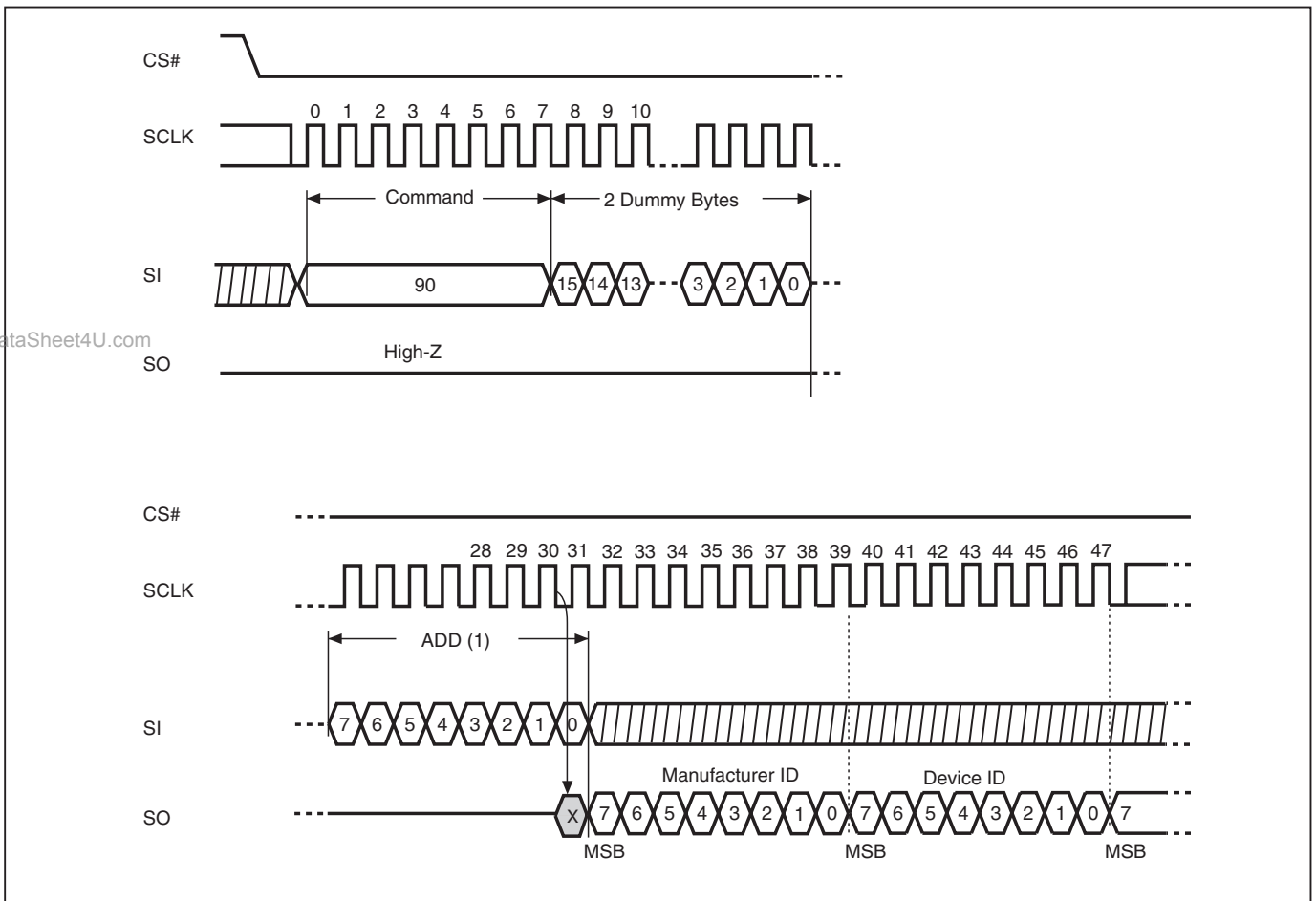

Figure 35. Read Electronic Manufacturer & Device ID (REMS) Sequence (Command 90 or EF or DF or CF)



Notes:

- (1) ADD=00h will output the Manufacturer ID first and ADD=01h will output Device ID first
- (2) Instruction is either 90(hex) or EF(hex) or DF(hex) or CF(hex).

Figure 36. READ ARRAY SEQUENCE (Parallel)

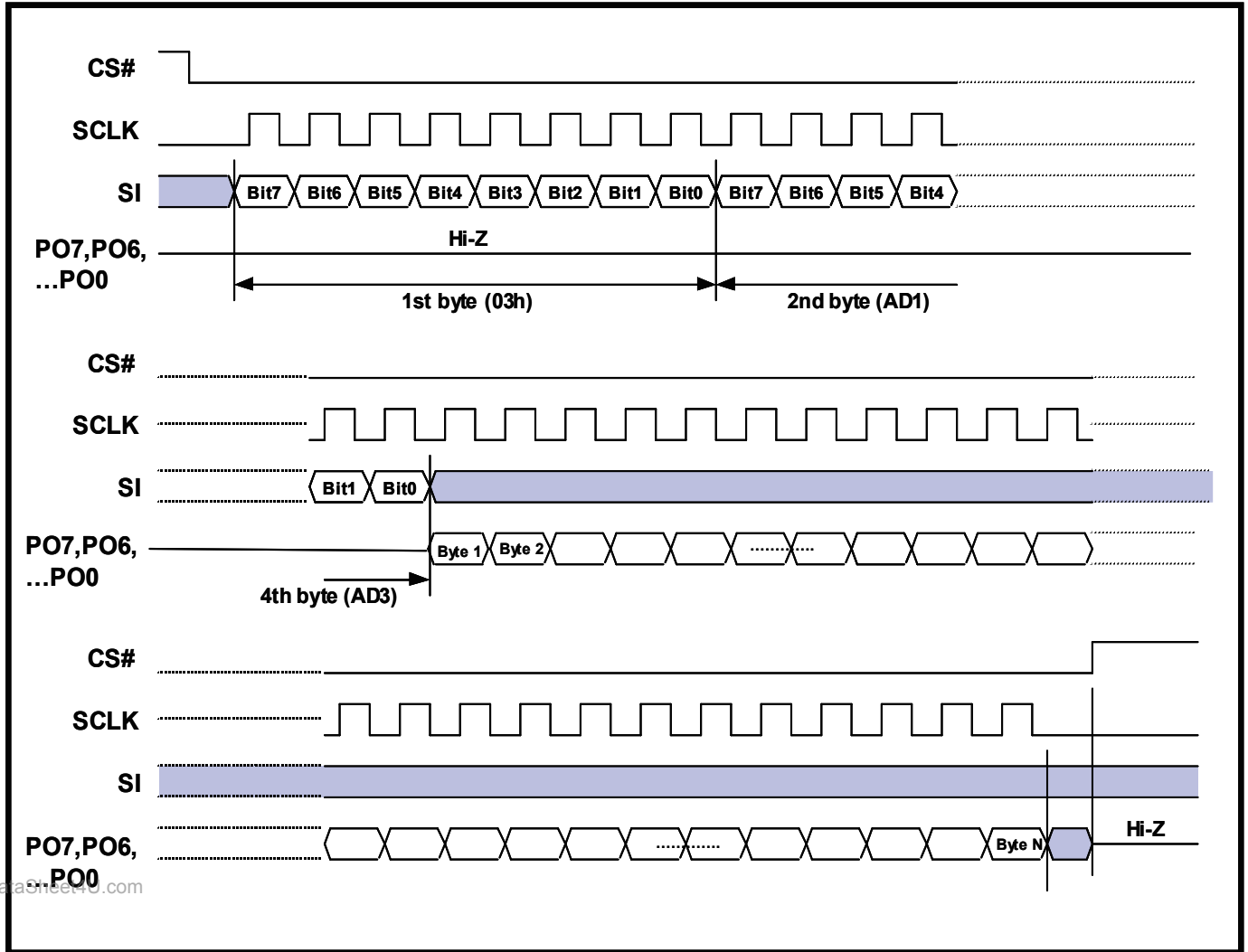

Notes :

1. 1st Byte='03h'
2. 2nd Byte=Address 1(AD1), AD23=bit7, AD22=bit6, AD21=bit5, AD20=bit4,....AD16=bit0.
3. 3rd Byte=Address 2(AD2), AD15=bit7, AD14=bit6, AD13=bit5, AD12=bit4,....AD8=bit0.
4. 4th Byte=Address 3(AD3), AD7=bit7, AD6=bit6,AD0=bit0.
5. From Byte 5, PO7-0 Would Output Array Data.
6. Under parallel mode, the fastest access clock freq. will be changed to 6MHz(SCLK pin clock freq.).
7. To read array in parallel mode requires a parallel mode command (55h) before the read command.
To exit parallel mode, it requires a (45h) command or power-off/on sequence.

Figure 37. AUTO PAGE PROGRAM TIMING SEQUENCE (Parallel)

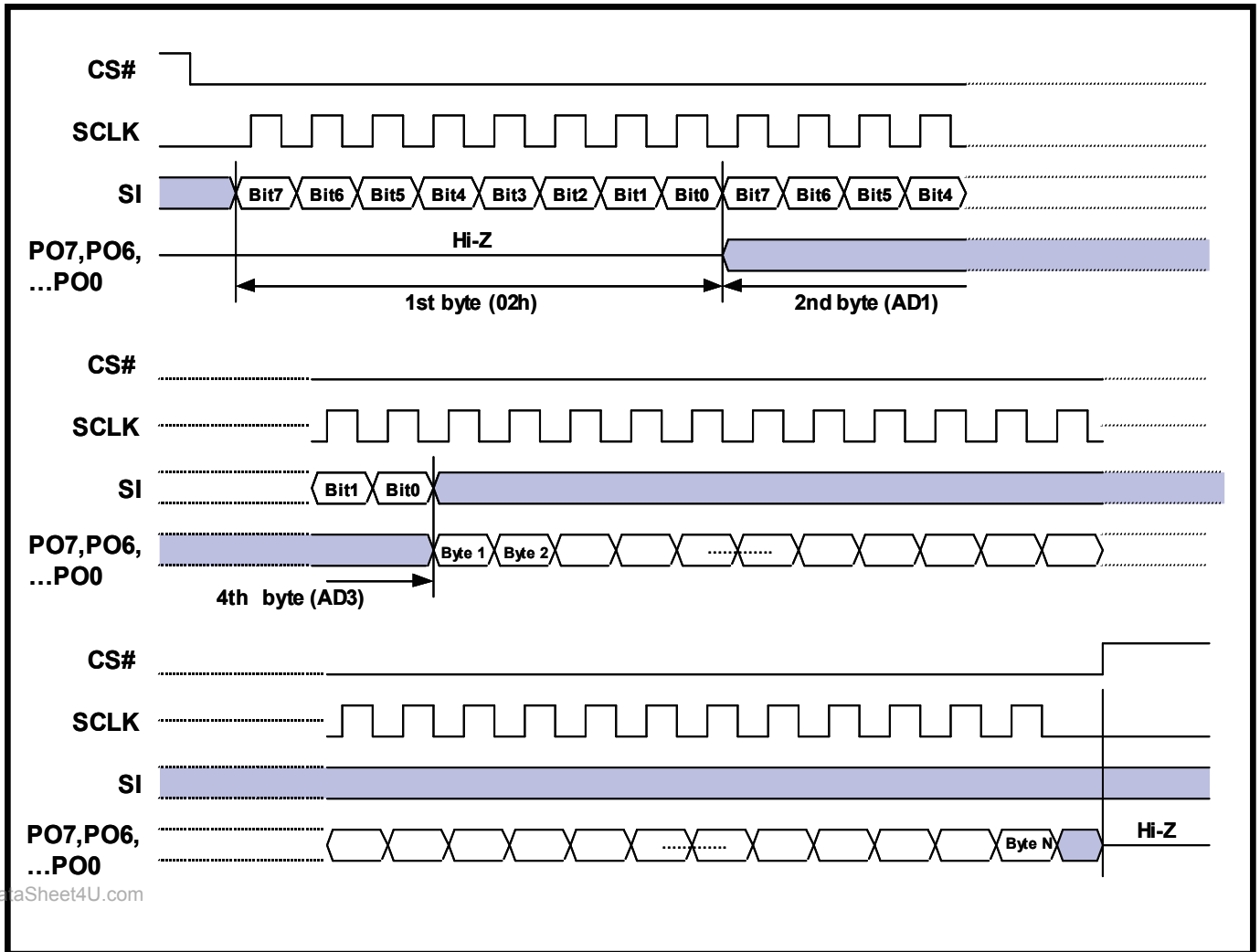

www.DataSheet4U.com

Notes :

1. 1st Byte='02h'
2. 2nd Byte=Address 1(AD1), AD23=bit7, AD22=bit6, AD21=bit5, AD20=bit4,....AD16=bit0.
3. 3rd Byte=Address 2(AD2), AD15=bit7, AD14=bit6, AD13=bit5, AD12=bit4,....AD8=bit0.
4. 4th Byte=Address 3(AD3), AD7=bit7, AD6=bit6,AD0=bit0.
5. 5th byte: 1st write data byte.
6. Under parallel mode, the fastest access clock freq. will be changed to 6MHz(SCLK pin clock freq.).
7. To program in parallel mode requires a parallel mode command (55h) before the program command.
To exit parallel mode, it requires a (45h) command or power-off/on sequence.

Figure 38. Release from Deep Power-down and Read Electronic Signature (RES) Sequence (Parallel)

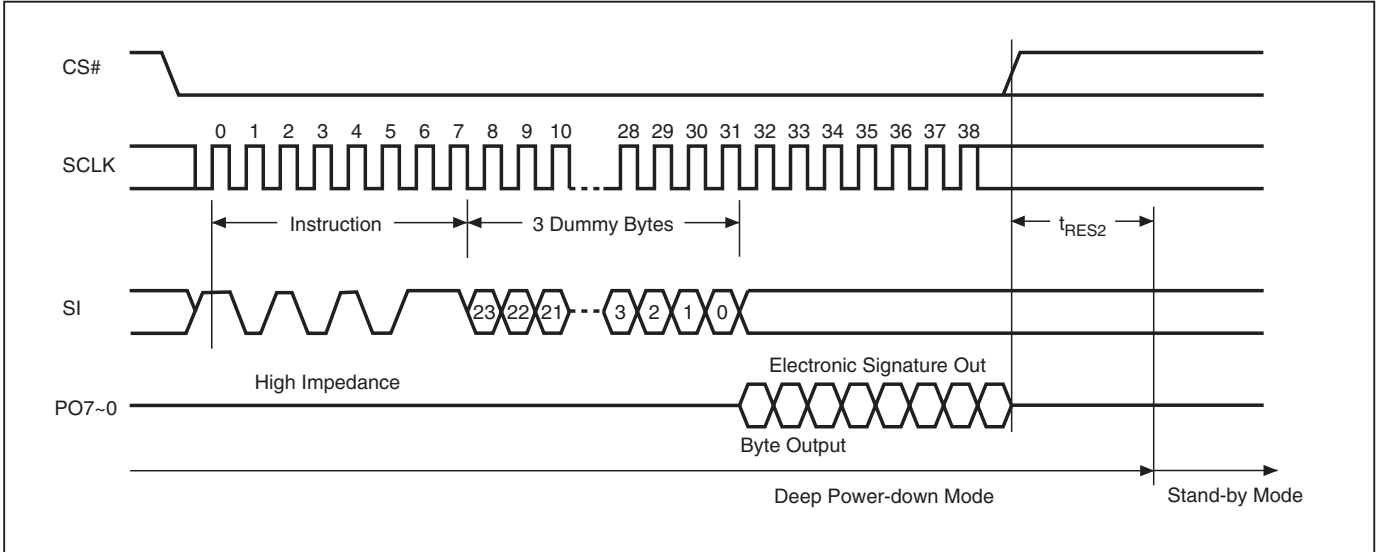

Notes :

- Under parallel mode, the fastest access clock freq. will be changed to 6MHz(SCLK pin clock freq.)
To release from Deep Power-down mode and read ID in parallel mode, which requires a parallel mode command (55h) before the read status register command.
To exit parallel mode, it requires a (45h) command or power-off/on sequence.

Figure 39. Read Electronic Manufacturer & Device ID (REMS) Sequence (Parallel)

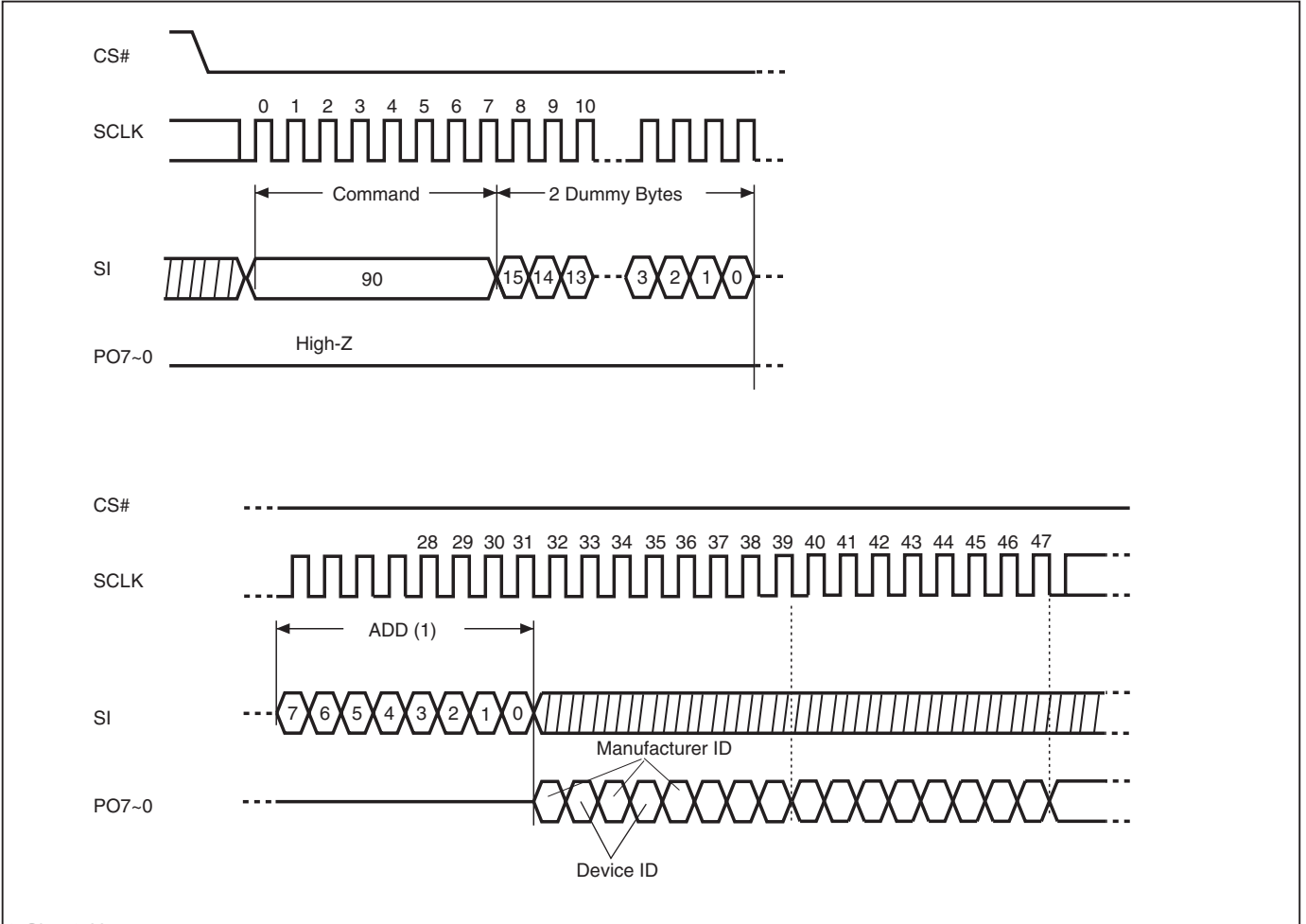

www.DataSheet4U.com

Notes :

1. ADD=00h will output the Manufacturer ID first and ADD=01h will output Device ID first.
2. Under parallel mode, the fastest access clock freq. will be changed to 6MHz(SCLK pin clock freq.)
To read ID in parallel mode, which requires a parallel mode command (55h) before the read ID command.
To exit Parallel mode, it requires a (45h) command or power-off/on sequence.

Figure 40. Write Protection Selection (WPSEL) Sequence (Command 68)

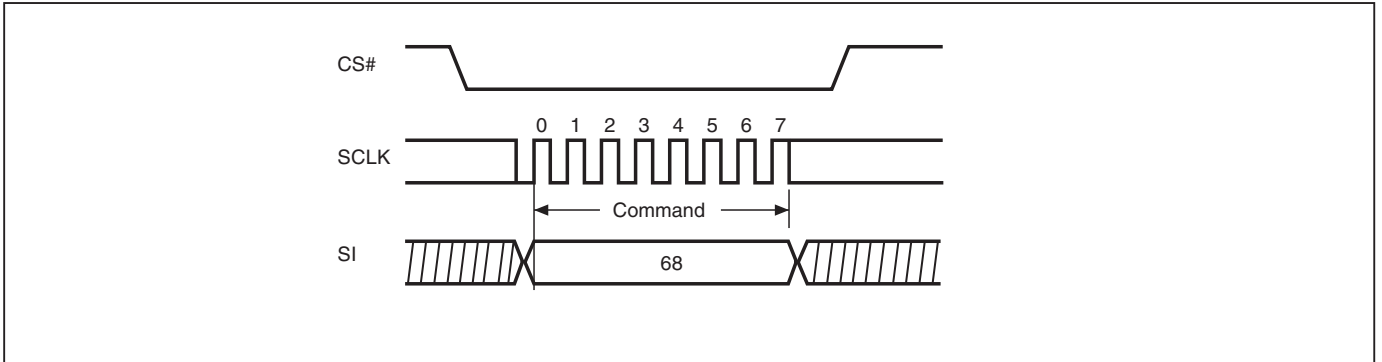
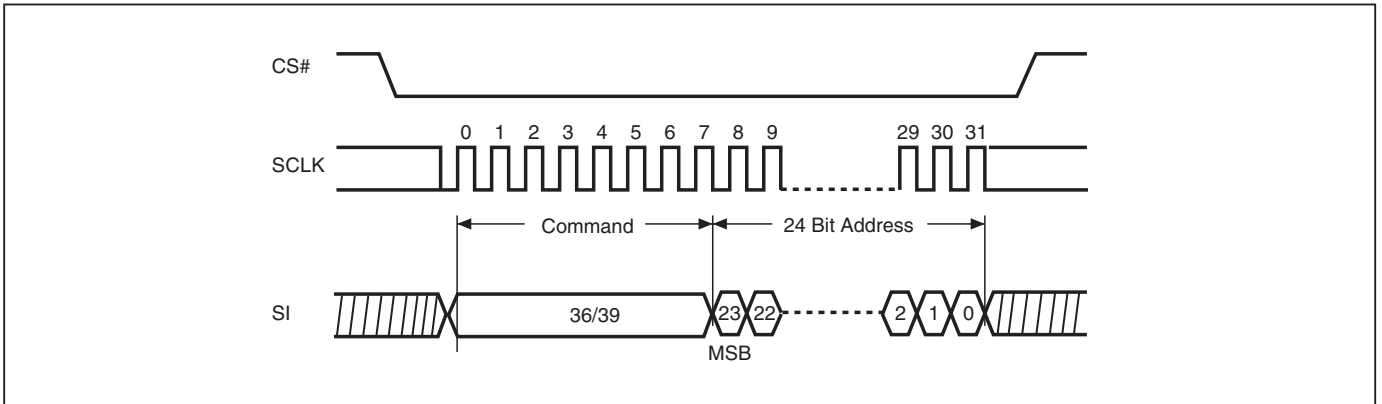

Figure 41. Single Block Lock/Unlock Protection (SBLK/SBULK) Sequence (Command 36/39)



www.DataSheet4U.com

Figure 42. Read Block Protection Lock Status (RDBLOCK) Sequence (Command 3C)

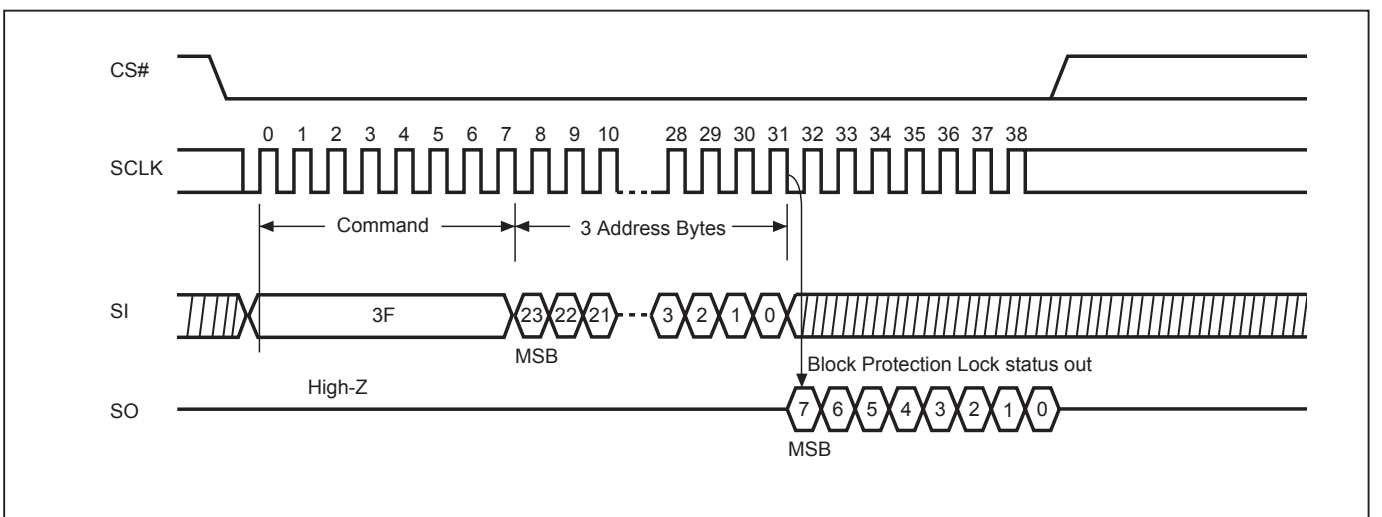

Figure 43. Gang Block Lock/Unlock (GBLK/GBULK) Sequence (Command 7E/98)

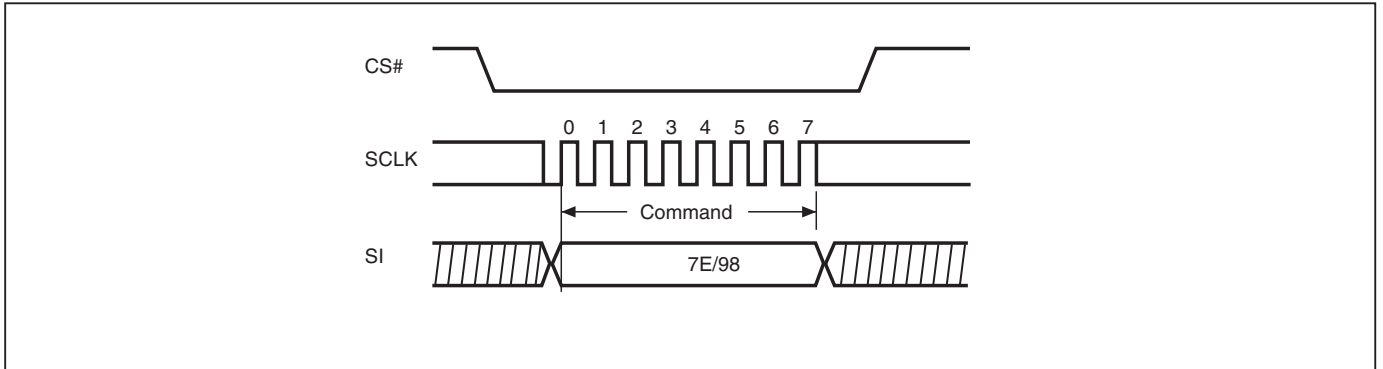
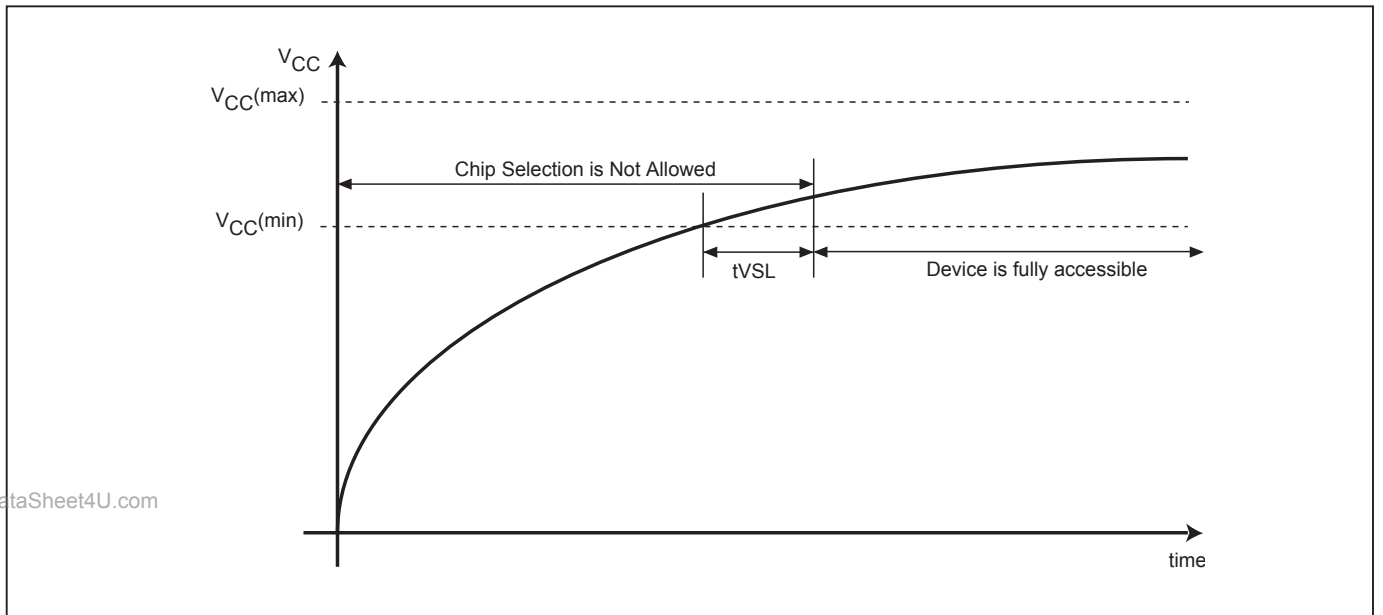

Figure 44. Power-up Timing



www.DataSheet4U.com

Note: VCC (max.) is 3.6V and VCC (min.) is 2.7V.

Table 9. Power-Up Timing

Symbol	Parameter	Min.	Max.	Unit
tVSL(1)	VCC(min) to CS# low	300		us

Note: 1. The parameter is characterized only.

INITIAL DELIVERY STATE

The device is delivered with the memory array erased: all bits are set to 1 (each byte contains FFh). The Status Register contains 00h (all Status Register bits are 0).

RECOMMENDED OPERATING CONDITIONS

At Device Power-Up

AC timing illustrated in Figure A is recommended for the supply voltages and the control signals at device power-up. If the timing in the figure is ignored, the device may not operate correctly.

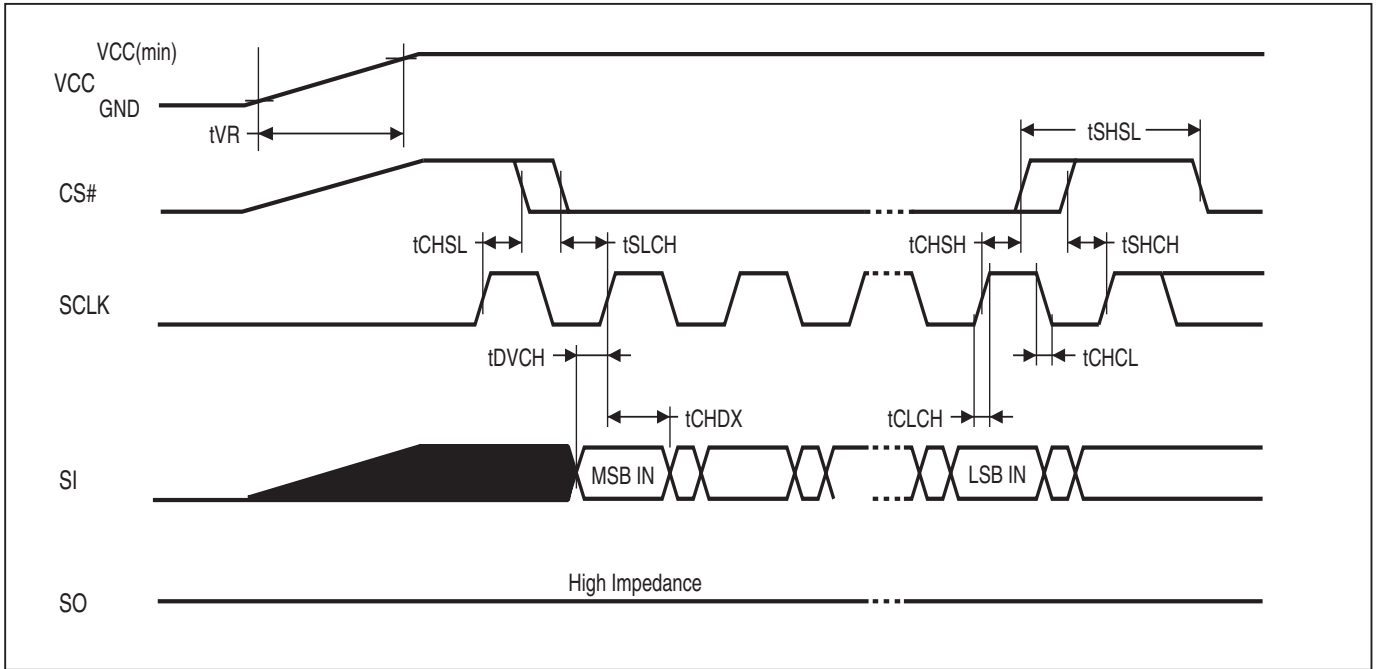

Figure A. AC Timing at Device Power-Up

www.DataSheet4U.com

Symbol	Parameter	Notes	Min.	Max.	Unit
tVR	VCC Rise Time	1	20	500000	us/V

Notes :

1. Sampled, not 100% tested.
2. For AC spec tCHSL, tSLCH, tDVCH, tCHDX, tSHSL, tCHSH, tSHCH, tCHCL, tCLCH in the figure, please refer to "AC CHARACTERISTICS" table.

ERASE AND PROGRAMMING PERFORMANCE

PARAMETER	Min.	TYP. (1)	Max. (2)	UNIT
Write Status Register Cycle Time		40	100	ms
Sector Erase Time (4KB)		90	300	ms
Block Erase Time (64KB)		0.7	2	s
Block Erase Time (32KB)		0.5	2	s
Chip Erase Time (128Mb)		80	512	s
Byte Program Time (via page program command)		9	300	us
Page Program Time		1.4	5	ms
Erase/Program Cycle		100,000		cycles

Note:

1. Typical program and erase time assumes the following conditions: 25°C, 3.3V, and checker board pattern.
2. Under worst conditions of 85°C and 2.7V.
3. System-level overhead is the time required to execute the first-bus-cycle sequence for the programming command.
4. The maximum chip programming time is evaluated under the worst conditions of 0°C, VCC=3.0V, and 100K cycle with 90% confidence level.

LATCH-UP CHARACTERISTICS

	MIN.	MAX.
Input Voltage with respect to GND on all power pins, SI, CS#	-1.0V	2 VCCmax
Input Voltage with respect to GND on SO	-1.0V	VCC + 1.0V
Current	-100mA	+100mA
Includes all pins except VCC. Test conditions: VCC = 3.0V, one pin at a time.		



ORDERING INFORMATION

Please contact Macronix sales for specific information regarding 16-pin SOP (300mil) and 24-ball TFBGA (10x13mm) ordering information.

PART NAME DESCRIPTION

Please contact Macronix sales for specific information regarding 16-pin SOP (300mil) and 24-ball TFBGA (10x13mm) part name description.

PACKAGE INFORMATION

Doc. Title: Package Outline for SOP 16L (300MIL)

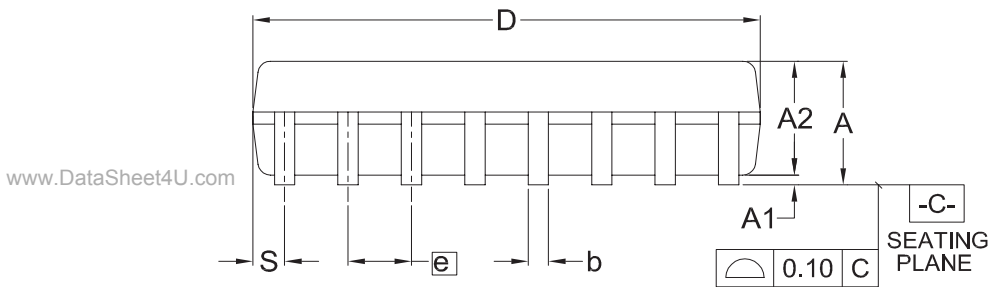
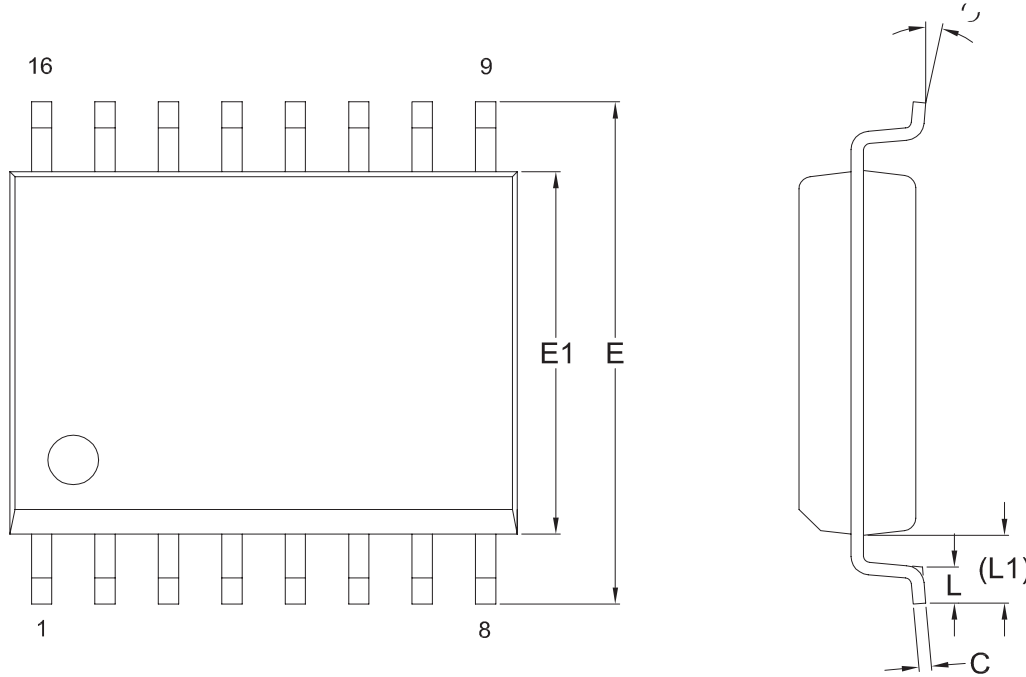

Dimensions (inch dimensions are derived from the original mm dimensions)

SYMBOL		A	A1	A2	b	C	D	E	E1	e	L	L1	S	θ
UNIT														
mm	Min.	---	0.10	2.34	0.36	0.20	10.10	10.10	7.42	---	0.40	1.31	0.51	0
	Nom.	---	0.20	2.39	0.41	0.25	10.30	10.30	7.52	1.27	0.84	1.44	0.64	5
	Max.	2.65	0.30	2.44	0.51	0.30	10.50	10.50	7.60	---	1.27	1.57	0.77	8
Inch	Min.	---	0.004	0.092	0.014	0.008	0.397	0.397	0.292	---	0.016	0.052	0.020	0
	Nom.	---	0.008	0.094	0.016	0.010	0.405	0.405	0.296	0.050	0.033	0.057	0.025	5
	Max.	0.104	0.012	0.096	0.020	0.012	0.413	0.413	0.299	---	0.050	0.062	0.030	8

Dwg. No.	Revision	Reference		
		JEDEC	EIAJ	
6110-1402	9	MS-013		

Doc. Title: Package Outline for CSP 24BALL (10x13x1.2MM, BALL PITCH 1.0MM, BALL DIAMETER 0.4MM)

TOP VIEW

BOTTOM VIEW

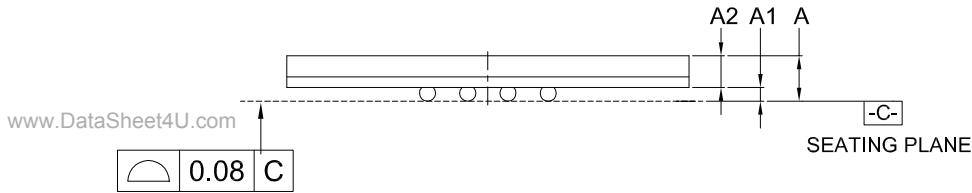
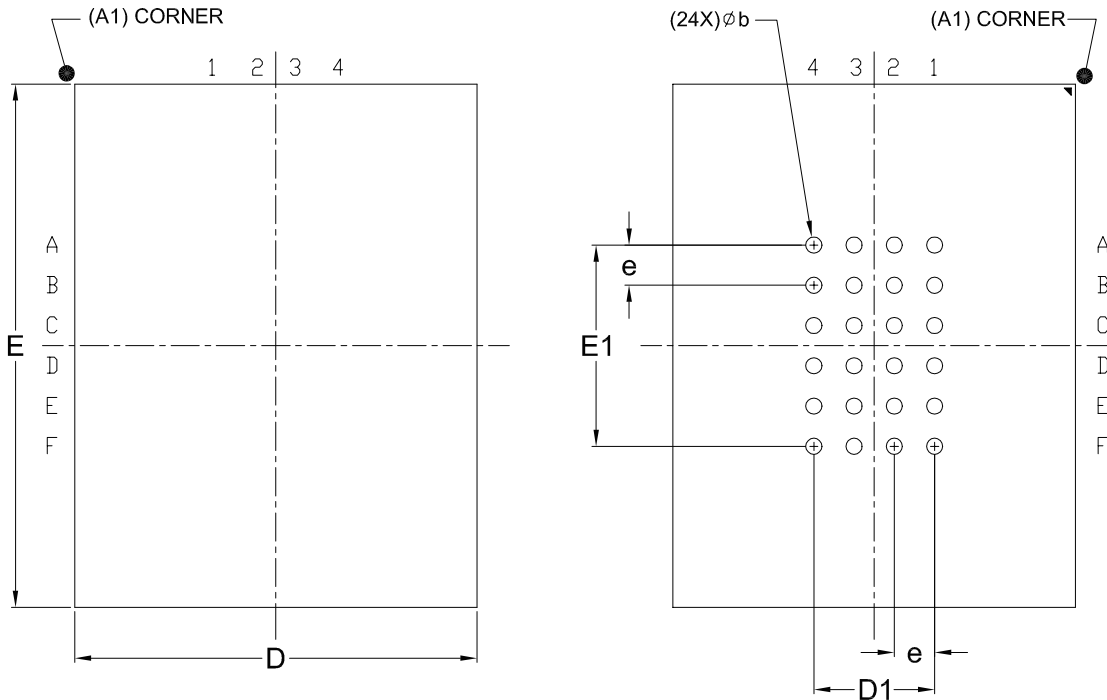

Dimensions (inch dimensions are derived from the original mm dimensions)

SYMBOL		A	A1	A2	b	D	D1	E	E1	e
UNIT										
mm	Min.	—	0.25	0.65	0.35	9.90	—	12.90	—	—
	Nom.	—	0.30	—	0.40	10.00	3.00	13.00	5.00	1.00
	Max.	1.20	0.35	—	0.45	10.10	—	13.10	—	—
Inch	Min.	—	0.010	0.026	0.014	0.390	—	0.508	—	—
	Nom.	—	0.012	—	0.016	0.394	0.120	0.512	0.200	0.039
	Max.	0.047	0.014	—	0.018	0.398	—	0.516	—	—

Dwg. No.	Revision	Reference			
		JEDEC	EIAJ		
6110-4220.1	1	MO-216			

REVISION HISTORY

Revision No.	Description	Page	Date
0.01	1. Modified tSLCH, tSHCH (VIO=1.65~2.2V) from 10ns to 20ns	P46	JUN/16/2008
0.02	1. Modified the performance enhance mode reset function description	P24,58	JUN/27/2008
0.03	1. Modified statement	All	JUL/29/2008
	2. Created additional instructions description	P34,41~43	
0.04	1. Corrected wording error	All	JAN/19/2009
	2. Removed MX25L6455E	All	
	3. Removed VIO function	All	
	4. Modified Status Register QE definition	P17	
	5. Added Block Erase Time (32KB)	P65	
	6. Added Note for 4xI/O Read Mode Sequence, Fast Quad I/O DT Read sequence and 4xI/O Read Enhance Mode Sequence	P51,52	
	7. Added 24-ball TFBGA	P6,8,66,68	
	8. Renamed Double data rate as Double transfer rate	All	
	9. Electrical Specifications: notice/overshoot waveform figure	P38	
	10. Table 7. DC Characteristics	P40	
	11. Table 8. AC Characteristics/notes	P41,42	
0.05	1. Added WRLCR command completion under "WEL bit is reset by following situation"	P10,16	MAR/05/2009
	2. Modified ICC2 & ICC4 from 20mA to 25mA	P5,40	
	3. Modified tCLQV, tCLQV2 and tCLQX	P41	
	4. Added tPL, tWRLR, tWPS & tWSR	P42	
	5. Changed tVSL spec from 200us (min.) to 300us (min.)	P63	
	6. Modified Figure 4. INPUT TEST WAVEFORMS AND MEASUREMENT LEVEL	P39	
	7. Revised RDSLOCK into RDBLOCK and added BE32K and 4PP	P13,15,16 P24,25	
	8. Added CFh	P27	
	9. Changed title from "Advanced Information" to "Preliminary"	P5	

Macronix's products are not designed, manufactured, or intended for use for any high risk applications in which the failure of a single component could cause death, personal injury, severe physical damage, or other substantial harm to persons or property, such as life-support systems, high temperature automotive, medical, aircraft and military application. Macronix and its suppliers will not be liable to you and/or any third party for any claims, injuries or damages that may be incurred due to use of Macronix's products in the prohibited applications.

Copyright© Macronix International Co. Ltd. 2008~2009. All Rights Reserved. Macronix, MXIC, MXIC Logo, MX Logo, are trademarks or registered trademarks of Macronix International Co., Ltd.. The names and brands of other companies are for identification purposes only and may be claimed as the property of the respective companies.

MACRONIX INTERNATIONAL Co., LTD.

Macronix Offices : Taiwan

Headquarters, FAB2

Macronix, International Co., Ltd.

16, Li-Hsin Road, Science Park, Hsinchu,
Taiwan, R.O.C.

Tel: +886-3-5786688

Fax: +886-3-5632888

Taipei Office

Macronix, International Co., Ltd.

19F, 4, Min-Chuan E. Road, Sec. 3, Taipei,
Taiwan, R.O.C.

Tel: +886-2-2509-3300

Fax: +886-2-2509-2200

Macronix Offices : China

Macronix (Hong Kong) Co., Limited.

702-703, 7/F, Building 9, Hong Kong Science Park,
5 Science Park West Avenue, Sha Tin,
N.T.

Tel: +86-852-2607-4289

Fax: +86-852-2607-4229

Macronix (Hong Kong) Co., Limited,

SuZhou Office

No.5, XingHai Rd, SuZhou Industrial Park,
SuZhou China 215021

Tel: +86-512-62580888 Ext: 3300

Fax: +86-512-62586799

Macronix (Hong Kong) Co., Limited,

Shenzhen Office

Room 1401 & 1404, Blcok A, TianAN Hi-Tech PLAZA Tower,
Che Gong Miao, FutianDistrict, Shenzhen PRC 518040

Tel: +86-755-83433579

Fax: +86-755-83438078

Macronix Offices : Japan

Macronix Asia Limited.

NKF Bldg. 5F, 1-2 Higashida-cho,
Kawasaki-ku Kawasaki-shi,
Kanagawa Pref. 210-0005, Japan

Tel: +81-44-246-9100

Fax: +81-44-246-9105

Macronix Offices : Korea

Macronix Asia Limited.

#906, 9F, Kangnam Bldg., 1321-4, Seocho-Dong, Seocho-Ku,
135-070, Seoul, Korea

Tel: +82-02-588-6887

Fax: +82-02-588-6828

Macronix Offices : Singapore

Macronix Pte. Ltd.

1 Marine Parade Central, #11-03 Parkway Centre,
Singapore 449408

Tel: +65-6346-5505

Fax: +65-6348-8096

Macronix Offices : Europe

Macronix Europe N.V.

Koningin Astridlaan 59, Bus 1 1780
Wemmel Belgium

Tel: +32-2-456-8020

Fax: +32-2-456-8021

Macronix Offices : USA

Macronix America, Inc.

680 North McCarthy Blvd. Milpitas, CA 95035,
U.S.A.

Tel: +1-408-262-8887

Fax: +1-408-262-8810

[http : //www.macronix.com](http://www.macronix.com)