



MX26LV800T/B

Macronix NBit™ Memory Family

8M-BIT [1Mx8/512Kx16] CMOS SINGLE VOLTAGE
3V ONLY HIGH SPEED eLiteFlash™ MEMORY

FEATURES

- Extended single - supply voltage range 3.0V to 3.6V
- 1,048,576 x 8/524,288 x 16 switchable
- Single power supply operation
 - 3.0V only operation for read, erase and program operation
- Fast access time: 55/70ns
- Low power consumption
 - 30mA maximum active current
 - 30uA typical standby current
- Command register architecture
 - Byte/word Programming (55us/70us typical)
 - Sector Erase (Sector structure 16K-Bytex1, 8K-Bytex2, 32K-Bytex1, and 64K-Byte x15)
- Auto Erase (chip & sector) and Auto Program
 - Automatically erase any combination of sectors with Erase verify capability.
 - Automatically program and verify data at specified address
- Status Reply
 - Data# polling & Toggle bit for detection of program and erase operation completion.
- Ready/Busy# pin (RY/BY#)
 - Provides a hardware method of detecting program or erase operation completion.
- 2,000 minimum erase/program cycles
- Latch-up protected to 100mA from -1V to VCC+1V
- Boot Sector Architecture
 - T = Top Boot Sector
 - B = Bottom Boot Sector
- Package type:
 - 48-pin TSOP
 - 48-ball CSP
- Compatibility with JEDEC standard
 - Pinout and software compatible with single-power supply Flash
- 20 years data retention

GENERAL DESCRIPTION

The MX26LV800T/B is a 8-mega bit high speed Flash memory organized as 1M bytes of 8 bits or 512K words of 16 bits. MXIC's high speed Flash memories offer the most cost-effective and reliable read/write non-volatile random access memory. The MX26LV800T/B is packaged in 48-pin TSOP, and 48-ball CSP. It is designed to be reprogrammed and erased in system or in standard EPROM programmers.

The standard MX26LV800T/B offers access time as fast as 55ns, allowing operation of high-speed microprocessors without wait states. To eliminate bus contention, the MX26LV800T/B has separate chip enable (CE#) and output enable (OE#) controls.

MXIC's high speed Flash memories augment EPROM functionality with in-circuit electrical erasure and programming. The MX26LV800T/B uses a command register to manage this functionality. The command register allows

for 100% TTL level control inputs and fixed power supply levels during erase and programming, while maintaining maximum EPROM compatibility.

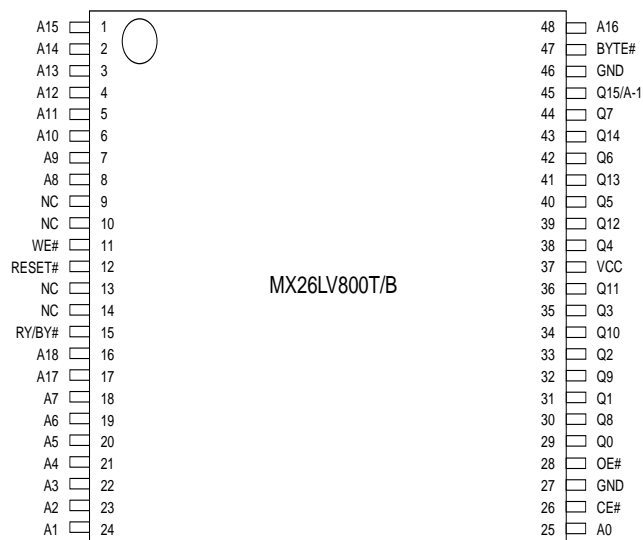
MXIC high speed Flash technology reliably stores memory contents even after 2,000 erase and program cycles. The MXIC cell is designed to optimize the erase and programming mechanisms. In addition, the combination of advanced tunnel oxide processing and low internal electric fields for erase and program operations produces reliable cycling. The MX26LV800T/B uses a 3.0V~3.6V VCC supply to perform the High Reliability Erase and auto Program/Erase algorithms.

The highest degree of latch-up protection is achieved with MXIC's proprietary non-epi process. Latch-up protection is proved for stresses up to 100 milliamperes on address and data pin from -1V to VCC + 1V.

www.DataSheet4U.com

PIN CONFIGURATIONS

48 TSOP (Standard Type) (12mm x 20mm)



PIN DESCRIPTION

SYMBOL	PIN NAME
A0~A18	Address Input
Q0~Q14	Data Input/Output
Q15/A-1	Q15(Word mode)/LSB addr(Byte mode)
CE#	Chip Enable Input
WE#	Write Enable Input
BYTE#	Word/Byte Selection input
RESET#	Hardware Reset Pin
OE#	Output Enable Input
RY/BY#	Ready/Busy Output
VCC	Power Supply Pin (3.0V~3.6V)
GND	Ground Pin

48-Ball CSP Ball Pitch = 0.8 mm, Top View, Balls Facing Down

	A	B	C	D	E	F	G	H
6	A13	A12	A14	A15	A16	BYTE#	Q15/A-1	GND
5	A9	A8	A10	A11	Q7	Q14	Q13	Q6
4	WE#	RESET#	NC	NC	Q5	Q12	Vcc	Q4
3	RY/BY#	NC	A18	NC	Q2	Q10	Q11	Q3
2	A7	A17	A6	A5	Q0	Q8	Q9	Q1
1	A3	A4	A2	A1	A0	CE#	OE#	GND

BLOCK STRUCTURE
TABLE 1: MX26LV800T SECTOR ARCHITECTURE

Sector	Sector Size		Address range		Sector Address						
	Byte Mode	Word Mode	Byte Mode (x8)	Word Mode (x16)	A18	A17	A16	A15	A14	A13	A12
SA0	64Kbytes	32Kwords	00000h-0FFFFh	00000h-07FFFh	0	0	0	0	X	X	X
SA1	64Kbytes	32Kwords	10000h-1FFFFh	08000h-0FFFFh	0	0	0	1	X	X	X
SA2	64Kbytes	32Kwords	20000h-2FFFFh	10000h-17FFFh	0	0	1	0	X	X	X
SA3	64Kbytes	32Kwords	30000h-3FFFFh	18000h-1FFFFh	0	0	1	1	X	X	X
SA4	64Kbytes	32Kwords	40000h-4FFFFh	20000h-27FFFh	0	1	0	0	X	X	X
SA5	64Kbytes	32Kwords	50000h-5FFFFh	28000h-2FFFFh	0	1	0	1	X	X	X
SA6	64Kbytes	32Kwords	60000h-6FFFFh	30000h-37FFFh	0	1	1	0	X	X	X
SA7	64Kbytes	32Kwords	70000h-7FFFFh	38000h-3FFFFh	0	1	1	1	X	X	X
SA8	64Kbytes	32Kwords	80000h-8FFFFh	40000h-47FFFh	1	0	0	0	X	X	X
SA9	64Kbytes	32Kwords	90000h-9FFFFh	48000h-4FFFFh	1	0	0	1	X	X	X
SA10	64Kbytes	32Kwords	A0000h-AFFFFh	50000h-57FFFh	1	0	1	0	X	X	X
SA11	64Kbytes	32Kwords	B0000h-BFFFFh	58000h-5FFFFh	1	0	1	1	X	X	X
SA12	64Kbytes	32Kwords	C0000h-CFFFFh	60000h-67FFFh	1	1	0	0	X	X	X
SA13	64Kbytes	32Kwords	D0000h-DFFFFh	68000h-6FFFFh	1	1	0	1	X	X	X
SA14	64Kbytes	32Kwords	E0000h-EFFFFh	70000h-77FFFh	1	1	1	0	X	X	X
SA15	32Kbytes	16Kwords	F0000h-F7FFFh	78000h-7BFFFh	1	1	1	1	0	X	X
SA16	8Kbytes	4Kwords	F8000h-F9FFFh	7C000h-7CFFFh	1	1	1	1	1	0	0
SA17	8Kbytes	4Kwords	FA000h-FBFFFh	7D000h-7DFFFh	1	1	1	1	1	0	1
SA18	16Kbytes	8Kwords	FC000h-FFFFh	7E000h-7FFFFh	1	1	1	1	1	1	X

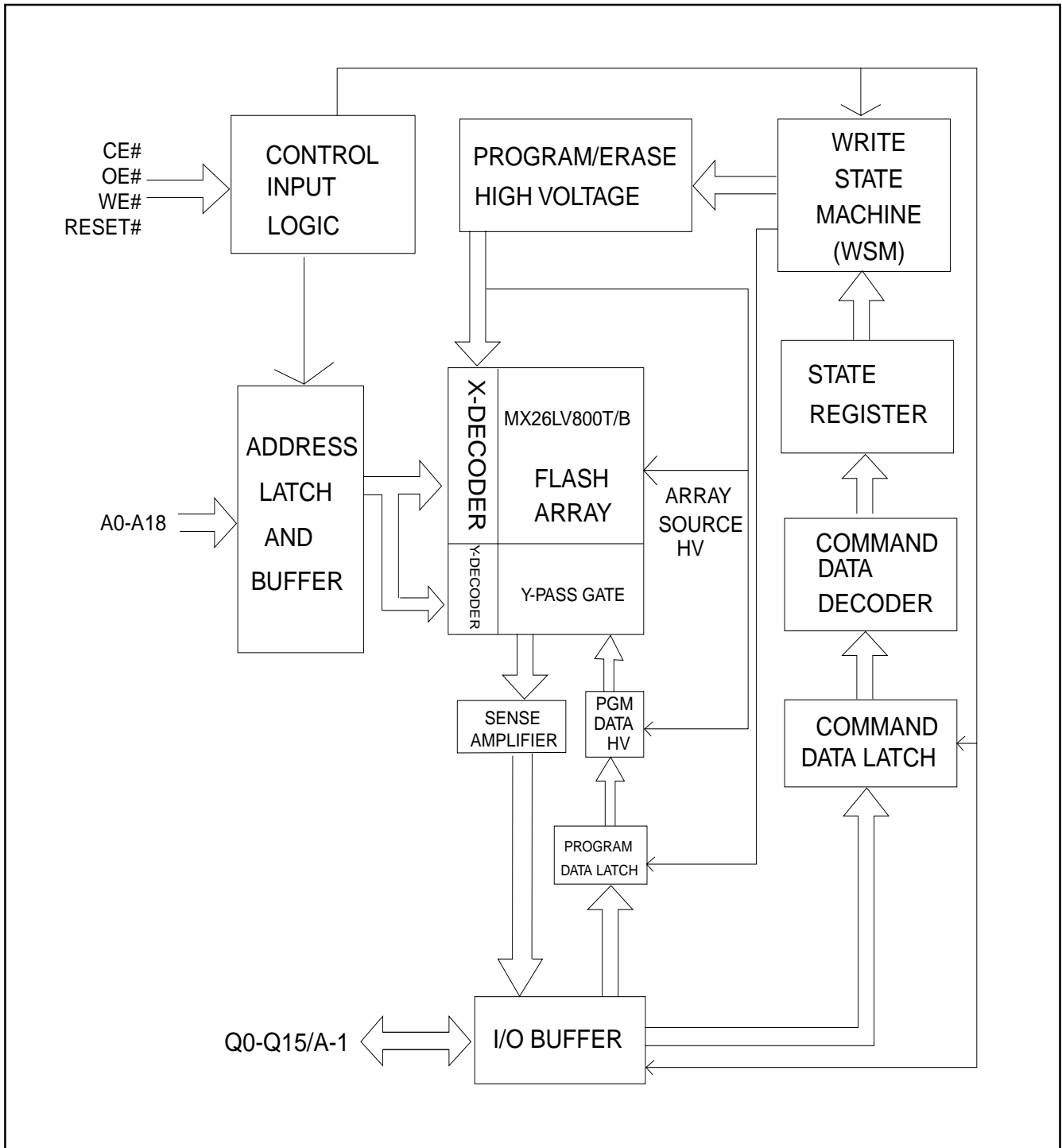
Note: Byte mode:address range A18:A-1, word mode:address range A18:A0.



TABLE 2: MX26LV800B SECTOR ARCHITECTURE

Sector	Sector Size		Address range		Sector Address						
	Byte Mode	Word Mode	Byte Mode (x8)	Word Mode (x16)	A18	A17	A16	A15	A14	A13	A12
SA0	16Kbytes	8Kwords	00000h-03FFFh	00000h-01FFFh	0	0	0	0	0	0	X
SA1	8Kbytes	4Kwords	04000h-05FFFh	02000h-02FFFh	0	0	0	0	0	1	0
SA2	8Kbytes	4Kwords	06000h-07FFFh	03000h-03FFFh	0	0	0	0	0	1	1
SA3	32Kbytes	16Kwords	08000h-0FFFFh	04000h-07FFFh	0	0	0	0	1	X	X
SA4	64Kbytes	32Kwords	10000h-1FFFFh	08000h-0FFFFh	0	0	0	1	X	X	X
SA5	64Kbytes	32Kwords	20000h-2FFFFh	10000h-17FFFh	0	0	1	0	X	X	X
SA6	64Kbytes	32Kwords	30000h-3FFFFh	18000h-1FFFFh	0	0	1	1	X	X	X
SA7	64Kbytes	32Kwords	40000h-4FFFFh	20000h-27FFFh	0	1	0	0	X	X	X
SA8	64Kbytes	32Kwords	50000h-5FFFFh	28000h-2FFFFh	0	1	0	1	X	X	X
SA9	64Kbytes	32Kwords	60000h-6FFFFh	30000h-37FFFh	0	1	1	0	X	X	X
SA10	64Kbytes	32Kwords	70000h-7FFFFh	38000h-3FFFFh	0	1	1	1	X	X	X
SA11	64Kbytes	32Kwords	80000h-8FFFFh	40000h-47FFFh	1	0	0	0	X	X	X
SA12	64Kbytes	32Kwords	90000h-9FFFFh	48000h-4FFFFh	1	0	0	1	X	X	X
SA13	64Kbytes	32Kwords	A0000h-AFFFFh	50000h-57FFFh	1	0	1	0	X	X	X
SA14	64Kbytes	32Kwords	B0000h-BFFFFh	58000h-5FFFFh	1	0	1	1	X	X	X
SA15	64Kbytes	32Kwords	C0000h-CFFFFh	60000h-67FFFh	1	1	0	0	X	X	X
SA16	64Kbytes	32Kwords	D0000h-DFFFFh	68000h-6FFFFh	1	1	0	1	X	X	X
SA17	64Kbytes	32Kwords	E0000h-EFFFFh	70000h-77FFFh	1	1	1	0	X	X	X
SA18	64Kbytes	32Kwords	F0000h-FFFFFh	78000h-7FFFFh	1	1	1	1	X	X	X

Note: Byte mode:address range A18:A-1, word mode:address range A18:A0.

BLOCK DIAGRAM


AUTOMATIC PROGRAMMING

The MX26LV800T/B is word/byte programmable using the Automatic Programming algorithm. The Automatic Programming algorithm makes the external system do not need to have time out sequence nor to verify the data programmed. The typical chip programming time at room temperature of the MX26LV800T/B is less than 35 seconds.

AUTOMATIC PROGRAMMING ALGORITHM

MXIC's Automatic Programming algorithm requires the user to only write program set-up commands (including 2 unlock write cycle and A0H) and a program command (program data and address). The device automatically times the programming pulse width, provides the program verification, and counts the number of sequences. A status bit similar to DATA# polling and a status bit toggling between consecutive read cycles, provide feedback to the user as to the status of the programming operation. Refer to write operation status, table 7, for more information on these status bits.

AUTOMATIC CHIP ERASE

The entire chip is bulk erased using 10 ms erase pulses according to MXIC's Automatic Chip Erase algorithm. Typical erasure at room temperature is accomplished in less than 40 second. The Automatic Erase algorithm automatically programs the entire array prior to electrical erase. The timing and verification of electrical erase are controlled internally within the device.

AUTOMATIC SECTOR ERASE

The MX26LV800T/B is sector(s) erasable using MXIC's Auto Sector Erase algorithm. The Automatic Sector Erase algorithm automatically programs the specified sector(s) prior to electrical erase. The timing and verification of electrical erase are controlled internally within the device. An erase operation can erase one sector, multiple sectors, or the entire device.

AUTOMATIC ERASE ALGORITHM

MXIC's Automatic Erase algorithm requires the user to

write commands to the command register using standard microprocessor write timings. The device will automatically pre-program and verify the entire array. Then the device automatically times the erase pulse width, provides the erase verification, and counts the number of sequences. A status bit toggling between consecutive read cycles provides feedback to the user as to the status of the erasing operation.

Register contents serve as inputs to an internal state-machine which controls the erase and programming circuitry. During write cycles, the command register internally latches address and data needed for the programming and erase operations. During a system write cycle, addresses are latched on the falling edge, and data are latched on the rising edge of WE# or CE#, whichever happens first.

MXIC's high speed Flash technology combines years of EPROM experience to produce the highest levels of quality, reliability, and cost effectiveness. The MX26LV800T/B electrically erases all bits simultaneously using Fowler-Nordheim tunneling. The bytes are programmed by using the EPROM programming mechanism of hot electron injection.

During a program cycle, the state-machine will control the program sequences and command register will not respond to any command set. After the state machine has completed its task, it will allow the command register to respond to its full command set.

AUTOMATIC SELECT

The auto select mode provides manufacturer and device identification, through identifier codes output on Q7~Q0. This mode is mainly adapted for programming equipment on the device to be programmed with its programming algorithm. When programming by high voltage method, automatic select mode requires VID (11V to 12V) on address pin A9 and other address pin A6, A1 and A0 as referring to Table 3. In addition, to access the automatic select codes in-system, the host can issue the automatic select command through the command register without requiring VID, as shown in table 5.



TABLE 3. MX26LV800T/B AUTO SELECT MODE OPERATION

Description		Mode	CE#	OE#	WE#	A18	A11	A9	A8	A6	A5	A1	A0	Q15~Q0
						 A12	 A10		 A7		 A2			
Read Silicon ID	Manufacturer Code		L	L	H	X	X	VID	X	L	X	L	L	C2H
	Device ID (Top Boot Block)	Word	L	L	H	X	X	VID	X	L	X	L	H	22DAH
		Byte	L	L	H	X	X	VID	X	L	X	L	H	XXDAH
	Device ID (Bottom Boot Block)	Word	L	L	H	X	X	VID	X	L	X	L	H	225BH
		Byte	L	L	H	X	X	VID	X	L	X	L	H	XX5BH

NOTE:SA=Sector Address, X=Don't Care, L=Logic Low, H=Logic High

TABLE 4. MX26LV800T/B COMMAND DEFINITIONS

Command	Bus Cycle	First Bus Cycle		Second Bus Cycle		Third Bus Cycle		Fourth Bus Cycle		Fifth Bus Cycle		Sixth Bus Cycle		
		Addr	Data	Addr	Data	Addr	Data	Addr	Data	Addr	Data	Addr	Data	
Reset	1	XXXH	F0H											
Read	1	RA	RD											
Read Silicon ID	Word	4	555H	AAH	2AAH	55H	555H	90H	ADI	DDI				
	Byte	4	AAAH	AAH	555H	55H	AAAH	90H	ADI	DDI				
Program	Word	4	555H	AAH	2AAH	55H	555H	A0H	PA	PD				
	Byte	4	AAAH	AAH	555H	55H	AAAH	A0H	PA	PD				
Chip Erase	Word	6	555H	AAH	2AAH	55H	555H	80H	555H	AAH	2AAH	55H	555H	10H
	Byte	6	AAAH	AAH	555H	55H	AAAH	80H	AAAH	AAH	555H	55H	AAAH	10H
Sector Erase	Word	6	555H	AAH	2AAH	55H	555H	80H	555H	AAH	2AAH	55H	SA	30H
	Byte	6	AAAH	AAH	555H	55H	AAAH	80H	AAAH	AAH	555H	55H	SA	30H

Note:

- ADI = Address of Device identifier; A1=0, A0 = 0 for manufacturer code, A1=0, A0 = 1 for device code. A2-A18=do not care. (Refer to table 3)
 DDI = Data of Device identifier : C2H for manufacture code, 22DA/DA(Top), and 225B/5B(Bottom) for device code.
 X = X can be VIL or VIH
 RA=Address of memory location to be read.
 RD=Data to be read at location RA.
- PA = Address of memory location to be programmed.
 PD = Data to be programmed at location PA.
 SA = Address of the sector.
- The system should generate the following address patterns: 555H or 2AAH to Address A10~A0 in word mode/AAAH or 555H to Address A10~A-1 in byte mode.
 Address bit A11~A18=X=Don't care for all address commands except for Program Address (PA) and Sector Address (SA).
 Write Sequence may be initiated with A11~A18 in either state.

COMMAND DEFINITIONS

Device operations are selected by writing specific address and data sequences into the command register. Writing incorrect address and data values or writing them in the improper sequence will reset the device to the read mode. Table 5 defines the valid register command sequences.

TABLE 5. MX26LV800T/B BUS OPERATION

DESCRIPTION	CE#	OE#	WE#	RESET#	ADDRESS								Q0~Q7	Q8~Q15	
					A18	A10	A9	A8	A6	A5	A1	A0		BYTE =VIH	BYTE =VIL
					A12	A11		A7		A2					
Read	L	L	H	H	AIN								Dout	Dout	Q8~Q14 =High Z Q15=A-1
Write	L	H	L	H	AIN								DIN(3)	DIN	
Reset	X	X	X	L	X								High Z	High Z	High Z
Output Disable	L	H	H	H	X								High Z	High Z	High Z
Standby	Vcc± 0.3V	X	X	Vcc± 0.3V	X								High Z	High Z	High Z

NOTES:

1. Manufacturer and device codes may also be accessed via a command register write sequence. Refer to Table 5.
2. VID is the Silicon-ID-Read high voltage, 11V to 12V.
3. Refer to Table 5 for valid Data-In during a write operation.
4. X can be VIL or VIH.

REQUIREMENTS FOR READING ARRAY DATA

To read array data from the outputs, the system must drive the CE# and OE# pins to VIL. CE# is the power control and selects the device. OE# is the output control and gates array data to the output pins. WE# should remain at VIH.

The internal state machine is set for reading array data upon device power-up, or after a hardware reset. This ensures that no spurious alteration of the memory content occurs during the power transition. No command is necessary in this mode to obtain array data. Standard microprocessor read cycles that assert valid address on the device address inputs produce valid data on the device data outputs. The device remains enabled for read access until the command register contents are altered.

WRITE COMMANDS/COMMAND SEQUENCES

To program data to the device or erase sectors of memory, the system must drive WE# and CE# to VIL, and OE# to VIH.

The "word/byte Program Command Sequence" section has details on programming data to the device.

An erase operation can erase one sector, multiple sectors, or the entire device. Table indicates the address space that each sector occupies. A "sector address" consists of the address bits required to uniquely select a sector. The "Writing specific address and data commands or sequences into the command register initiates device operations. Table 1 defines the valid register command sequences. Writing incorrect address and data values or writing them in the improper sequence resets the device to reading array data. Section has details on erasing a sector or the entire chip.

After the system writes the autoselect command sequence, the device enters the autoselect mode. The system can then read autoselect codes from the internal register (which is separate from the memory array) on Q7-Q0. Standard read cycle timings apply in this mode. Refer to the Autoselect Mode and Autoselect Command Sequence section for more information.

ICC2 in the DC Characteristics table represents the active current specification for the write mode. The "AC

Characteristics" section contains timing specification table and timing diagrams for write operations.

STANDBY MODE

When using both pins of CE# and RESET#, the device enter CMOS Standby with both pins held at $V_{cc} \pm 0.3V$. If CE# and RESET# are held at VIH, but not within the range of $V_{CC} \pm 0.3V$, the device will still be in the standby mode, but the standby current will be larger. During Auto Algorithm operation, V_{cc} active current (I_{cc2}) is required even CE# = "H" until the operation is completed. The device can be read with standard access time (t_{CE}) from either of these standby modes, before it is ready to read data.

OUTPUT DISABLE

With the OE# input at a logic high level (VIH), output from the devices are disabled. This will cause the output pins to be in a high impedance state.

RESET# OPERATION

The RESET# pin provides a hardware method of resetting the device to reading array data. When the RESET# pin is driven low for at least a period of t_{RP} , the device immediately terminates any operation in progress, tri-states all output pins, and ignores all read/write commands for the duration of the RESET# pulse. The device also resets the internal state machine to reading array data. The operation that was interrupted should be reinitiated once the device is ready to accept another command sequence, to ensure data integrity

Current is reduced for the duration of the RESET# pulse. When RESET# is held at $V_{SS} \pm 0.3V$, the device draws CMOS standby current (I_{CC4}). If RESET# is held at VIL but not within $V_{SS} \pm 0.3V$, the standby current will be greater.

The RESET# pin may be tied to system reset circuitry. A system reset would that also reset the high speed Flash, enabling the system to read the boot-up firmware from the high speed Flash.

If RESET# is asserted during a program or erase operation, the RY/BY# pin remains a "0" (busy) until the inter-

nal reset operation is complete, which requires a time of tREADY (during Embedded Algorithms). The system can thus monitor RY/BY# to determine whether the reset operation is complete. If RESET# is asserted when a program or erase operation is completed within a time of tREADY (not during Embedded Algorithms). The system can read data tRH after the RESET# pin returns to VIH.

Refer to the AC Characteristics tables for RESET# parameters and to Figure 22 for the timing diagram.

READ/RESET COMMAND

The read or reset operation is initiated by writing the read/reset command sequence into the command register. Microprocessor read cycles retrieve array data. The device remains enabled for reads until the command register contents are altered.

If program-fail or erase-fail happen, the write of F0H will reset the device to abort the operation. A valid command must then be written to place the device in the desired state.

SILICON-ID READ COMMAND

High speed Flash memories are intended for use in applications where the local CPU alters memory contents. As such, manufacturer and device codes must be accessible while the device resides in the target system. PROM programmers typically access signature codes by raising A9 to a high voltage (VID). However, multiplexing high voltage onto address lines is not generally desired system design practice.

The MX26LV800T/B contains a Silicon-ID-Read operation to supple traditional PROM programming methodology. The operation is initiated by writing the read silicon ID command sequence into the command register. Following the command write, a read cycle with A1=VIL, A0=VIL retrieves the manufacturer code of C2H/00C2H. A read cycle with A1=VIL, A0=VIH returns the device code of DAH/22DAH for MX26LV800T, 5BH/225BH for MX26LV800B.

SET-UP AUTOMATIC CHIP/SECTOR ERASE COMMANDS

Chip erase is a six-bus cycle operation. There are two "unlock" write cycles. These are followed by writing the "set-up" command 80H. Two more "unlock" write cycles are then followed by the chip erase command 10H or sector erase command 30H.

The Automatic Chip Erase does not require the device to be entirely pre-programmed prior to executing the Automatic Chip Erase. Upon executing the Automatic Chip Erase, the device will automatically program and verify the entire memory for an all-zero data pattern. When the device is automatically verified to contain an all-zero pattern, a self-timed chip erase and verify begin. The erase and verify operations are completed when the data on Q7 is "1" at which time the device returns to the Read mode. The system is not required to provide any control or timing during these operations.

When using the Automatic Chip Erase algorithm, note that the erase automatically terminates when adequate erase margin has been achieved for the memory array (no erase verification command is required).

If the Erase operation was unsuccessful, the data on Q5 is "1" (see Table 8), indicating the erase operation exceed internal timing limit.

The automatic erase begins on the rising edge of the last WE# or CE# pulse, whichever happens first in the command sequence and terminates when the data on Q7 is "1" at which time the device returns to the Read mode, or the data on Q6 stops toggling for two consecutive read cycles at which time the device returns to the Read mode.

TABLE 6. SILICON ID CODE

Pins		A0	A1	Q15~Q8	Q7	Q6	Q5	Q4	Q3	Q2	Q1	Q0	Code (Hex)
Manufacture code	Word	VIL	VIL	00H	1	1	0	0	0	0	1	0	00C2H
	Byte	VIL	VIL	X	1	1	0	0	0	0	1	0	C2H
Device code for MX26LV800T	Word	VIH	VIL	22H	1	1	0	1	1	0	1	0	22DAH
	Byte	VIH	VIL	X	1	1	0	1	1	0	1	0	DAH
Device code for MX26LV800B	Word	VIH	VIL	22H	0	1	0	1	1	0	1	1	225BH
	Byte	VIH	VIL	X	0	1	0	1	1	0	1	1	5BH

READING ARRAY DATA

The device is automatically set to reading array data after device power-up. No commands are required to retrieve data. The device is also ready to read array data after completing an Automatic Program or Automatic Erase algorithm.

The system must issue the reset command to re-enable the device for reading array data if Q5 goes high, or while in the autoselect mode. See the "Reset Command" section, next.

RESET COMMAND

Writing the reset command to the device resets the device to reading array data. Address bits are don't care for this command.

The reset command may be written between the sequence cycles in an erase command sequence before erasing begins. This resets the device to reading array data. Once erasure begins, however, the device ignores reset commands until the operation is complete.

The reset command may be written between the sequence cycles in a program command sequence before programming begins. This resets the device to reading array data. Once programming begins, however, the device ignores reset commands until the operation is complete.

The reset command may be written between the sequence cycles in an SILICON ID READ command sequence. Once in the SILICON ID READ mode, the reset command must be written to return to reading array data.

If Q5 goes high during a program or erase operation, writing the reset command returns the device to reading array data.

SECTOR ERASE COMMANDS

The Automatic Sector Erase does not require the device to be entirely pre-programmed prior to executing the Automatic Sector Erase Set-up command and Automatic Sector Erase command. Upon executing the Automatic Sector Erase command, the device will automatically program and verify the sector(s) memory for an all-zero data pattern. The system is not required to provide any control or timing during these operations.

When the sector(s) is automatically verified to contain an all-zero pattern, a self-timed sector erase and verify begin. The erase and verify operations are complete when either the data on Q7 is "1" at which time the device returns to the Read mode, or the data on Q6 stops toggling for two consecutive read cycles at which time the device returns to the Read mode. The system is not required to provide any control or timing during these operations.

When using the Automatic sector Erase algorithm, note that the erase automatically terminates when adequate erase margin has been achieved for the memory array (no erase verification command is required). Sector erase is a six-bus cycle operation. There are two "unlock" write cycles. These are followed by writing the set-up command 80H. Two more "unlock" write cycles are then followed by the sector erase command 30H. The sector address is latched on the falling edge of WE# or CE#, whichever happens later, while the command (data) is latched on the rising edge of WE# or CE#, whichever happens first. Sector addresses selected are loaded into internal register on the sixth falling edge of WE# or CE#, whichever happens later. Each successive sector load cycle started by the falling edge of WE# or CE#, whichever happens later must begin within 50us from the rising edge of the preceding WE# or CE#, whichever happens first. Otherwise, the loading period ends and internal auto sector erase cycle starts. (Monitor Q3 to determine if the sector erase timer window is still open, see section Q3, Sector Erase Timer.) Any command other than Sector Erase (30H) during the time-out period resets the device to read mode.

WORD/BYTE PROGRAM COMMAND SEQUENCE

The device programs one byte of data for each program operation. The command sequence requires four bus cycles, and is initiated by writing two unlock write cycles,

followed by the program set-up command. The program address and data are written next, which in turn initiate the Embedded Program algorithm. The system is not required to provide further controls or timings. The device automatically generates the program pulses and verifies the programmed cell margin. Table 1 shows the address and data requirements for the word/byte program command sequence.

When the Embedded Program algorithm is complete, the device then returns to reading array data and addresses are no longer latched. The system can determine the status of the program operation by using Q7, Q6, or RY/BY#. See "Write Operation Status" for information on these status bits.

Any commands written to the device during the Embedded Program Algorithm are ignored. Note that a hardware reset immediately terminates the programming operation. The word/byte Program command sequence should be reinitiated once the device has reset to reading array data, to ensure data integrity.

Programming is allowed in any sequence and across sector boundaries. A bit cannot be programmed from a "0" back to a "1". Attempting to do so may halt the operation and set Q5 to "1", or cause the Data# Polling algorithm to indicate the operation was successful. However, a succeeding read will show that the data is still "0". Only erase operations can convert a "0" to a "1".

WRITE OPERATION STATUS

The device provides several bits to determine the status of a write operation: Q2, Q3, Q5, Q6, Q7, and RY/BY#. Table 7 and the following subsections describe the functions of these bits. Q7, RY/BY#, and Q6 each offer a method for determining whether a program or erase operation is complete or in progress. These three bits are discussed first.

Q7: Data# Polling

The Data# Polling bit, Q7, indicates to the host system whether an Automatic Algorithm is in progress or completed. Data# Polling is valid after the rising edge of the final WE# pulse in the program or erase command sequence.

During the Automatic Program algorithm, the device outputs on Q7 the complement of the datum programmed to Q7. When the Automatic Program algorithm is complete, the device outputs the datum programmed to Q7. The system must provide the program address to read valid status information on Q7.

During the Automatic Erase algorithm, Data# Polling produces a "0" on Q7. When the Automatic Erase algorithm is complete, Data# Polling produces a "1" on Q7. This is analogous to the complement/true datum output described for the Automatic Program algorithm: the erase function changes all the bits in a sector to "1" prior to this, the device outputs the "complement," or "0." The system must provide an address within any of the sectors selected for erasure to read valid status information on Q7.

When the system detects Q7 has changed from the complement to true data, it can read valid data at Q7-Q0 on the following read cycles. This is because Q7 may change asynchronously with Q0-Q6 while Output Enable (OE#) is asserted low.

RY/BY# : Ready/Busy

The RY/BY# is a dedicated, open-drain output pin that indicates whether an Automatic Erase/Program algorithm is in progress or complete. The RY/BY# status is valid after the rising edge of the final WE# or CE#, whichever happens first, in the command sequence. Since RY/BY# is an open-drain output, several RY/BY# pins can be tied together in parallel with a pull-up resistor to VCC.

If the output is low (Busy), the device is actively erasing or programming. If the output is high (Ready), the device is ready to read array data, or is in the standby mode.

Table 7 shows the outputs for RY/BY# during write operation.

Q6:Toggle BIT I

Toggle Bit I on Q6 indicates whether an Automatic Program or Erase algorithm is in progress or complete. Toggle Bit I may be read at any address, and is valid after the rising edge of the final WE# or CE#, whichever happens first, in the command sequence (prior to the program or erase operation), and during the sector time-out.

During an Automatic Program or Erase algorithm operation, successive read cycles to any address cause Q6 to toggle. The system may use either OE# or CE# to control the read cycles. When the operation is complete, Q6 stops toggling.

When the device is actively erasing (that is, the Automatic Erase algorithm is in progress), Q6 toggling. However, the system must also use Q2 to determine which sectors are erasing. Alternatively, the system can use Q7.

Q6 stops toggling once the Automatic Program algorithm is complete.

Table 7 shows the outputs for Toggle Bit I on Q6.

Q2:Toggle Bit II

The "Toggle Bit II" on Q2, when used with Q6, indicates whether a particular sector is actively erasing (that is, the Automatic Erase algorithm is in process). Toggle Bit II is valid after the rising edge of the final WE# or CE#, whichever happens first, in the command sequence.

Q2 toggles when the system reads at addresses within those sectors that have been selected for erasure. (The system may use either OE# or CE# to control the read cycles.) But Q2 cannot distinguish when the sector is actively erasing. Q6, by comparison, indicates when the device is actively erasing, but cannot distinguish which sectors are selected for erasure. Thus, both status bits are required for sectors and mode information. Refer to Table 8 to compare outputs for Q2 and Q6.

Reading Toggle Bits Q6/ Q2

Whenever the system initially begins reading toggle bit status, it must read Q7-Q0 at least twice in a row to determine whether a toggle bit is toggling. Typically, the system would note and store the value of the toggle bit

after the first read. After the second read, the system would compare the new value of the toggle bit with the first. If the toggle bit is not toggling, the device has completed the program or erase operation. The system can read array data on Q7-Q0 on the following read cycle.

However, if after the initial two read cycles, the system determines that the toggle bit is still toggling, the system also should note whether the value of Q5 is high (see the section on Q5). If it is, the system should then determine again whether the toggle bit is toggling, since the toggle bit may have stopped toggling just as Q5 went high. If the toggle bit is no longer toggling, the device has successfully completed the program or erase operation. If it is still toggling, the device did not complete the operation successfully, and the system must write the reset command to return to reading array data.

The remaining scenario is that system initially determines that the toggle bit is toggling and Q5 has not gone high. The system may continue to monitor the toggle bit and Q5 through successive read cycles, determining the status as described in the previous paragraph. Alternatively, it may choose to perform other system tasks. In this case, the system must start at the beginning of the algorithm when it returns to determine the status of the operation.

Q5 Exceeded Timing Limits

Q5 will indicate if the program or erase time has exceeded the specified limits (internal pulse count). Under these conditions Q5 will produce a "1". This time-out condition indicates that the program or erase cycle was not successfully completed. Data# Polling and Toggle Bit are the only operating functions of the device under this condition.

If this time-out condition occurs during sector erase operation, it specifies that a particular sector is bad and it may not be reused. However, other sectors are still functional and may be used for the program or erase operation. The device must be reset to use other sectors. Write the Reset command sequence to the device, and then execute program or erase command sequence. This allows the system to continue to use the other active sectors in the device.

If this time-out condition occurs during the chip erase

operation, it specifies that the entire chip is bad or combination of sectors are bad.

If this time-out condition occurs during the word/byte programming operation, it specifies that the entire sector containing that byte is bad and this sector may not be reused, (other sectors are still functional and can be reused).

The time-out condition will not appear if a user tries to program a non blank location without erasing. Please note that this is not a device failure condition since the device was incorrectly used.

TABLE 7. WRITE OPERATION STATUS

	Status	Q7 (Note1)	Q6	Q5 (Note2)	Q3	Q2	RY/BY#
In Progress	Word/Byte Program in Auto Program Algorithm	$\overline{Q7}$	Toggle	0	N/A	No Toggle	0
	Auto Erase Algorithm	0	Toggle	0	1	Toggle	0
Exceeded Time Limits	Word/Byte Program in Auto Program Algorithm	$\overline{Q7}$	Toggle	1	N/A	No Toggle	0
	Auto Erase Algorithm	0	Toggle	1	1	Toggle	0

Note:

1. Q7 and Q2 require a valid address when reading status information. Refer to the appropriate subsection for further details.
2. Q5 switches to '1' when an Auto Program or Auto Erase operation has exceeded the maximum timing limits. See "Q5:Exceeded Timing Limits " for more information.

Q3**Sector Erase Timer**

After the completion of the initial sector erase command sequence, the sector erase time-out will begin. Q3 will remain low until the time-out is complete. Data# Polling and Toggle Bit are valid after the initial sector erase command sequence.

If Data# Polling or the Toggle Bit indicates the device has been written with a valid erase command, Q3 may be used to determine if the sector erase timer window is still open. If Q3 is high ("1") the internally controlled erase cycle has begun; attempts to write subsequent commands to the device will be ignored until the erase operation is completed as indicated by Data# Polling or Toggle Bit. If Q3 is low ("0"), the device will accept additional sector erase commands. To insure the command has been accepted, the system software should check the status of Q3 prior to and following each subsequent sector erase command. If Q3 were high on the second status check, the command may not have been accepted.

DATA PROTECTION

The MX26LV800T/B is designed to offer protection against accidental erasure or programming caused by spurious system level signals that may exist during power transition. During power up the device automatically resets the state machine in the Read mode. In addition, with its control register architecture, alteration of the memory contents only occurs after successful completion of specific command sequences. The device also incorporates several features to prevent inadvertent write cycles resulting from VCC power-up and power-down transition or system noise.

WRITE PULSE "GLITCH" PROTECTION

Noise pulses of less than 5ns(typical) on CE# or WE# will not initiate a write cycle.

LOGICAL INHIBIT

Writing is inhibited by holding any one of OE# = VIL, CE# = VIH or WE# = VIH. To initiate a write cycle CE# and WE# must be a logical zero while OE# is a logical one.

POWER SUPPLY DECOUPLING

In order to reduce power switching effect, each device should have a 0.1uF ceramic capacitor connected between its VCC and GND.

POWER-UP SEQUENCE

The MX26LV800T/B powers up in the Read only mode. In addition, the memory contents may only be altered after successful completion of the predefined command sequences.



ABSOLUTE MAXIMUM RATINGS

Storage Temperature
Plastic Packages -65°C to +150°C
Ambient Temperature
with Power Applied. -65°C to +125°C
Voltage with Respect to Ground
 VCC (Note 1) -0.5 V to +4.0 V
 A9, OE#, and
 RESET# (Note 2) -0.5 V to +12 V
 All other pins (Note 1) -0.5 V to VCC +0.5 V
Output Short Circuit Current (Note 3) 200 mA

Notes:

1. Minimum DC voltage on input or I/O pins is -0.5 V. During voltage transitions, input or I/O pins may overshoot VSS to -2.0 V for periods of up to 20 ns. See Figure 6. Maximum DC voltage on input or I/O pins is VCC +0.5 V. During voltage transitions, input or I/O pins may overshoot to VCC +2.0 V for periods up to 20 ns.
2. Minimum DC input voltage on pins A9, OE#, and RESET# is -0.5 V. During voltage transitions, A9, OE#, and RESET# may overshoot VSS to -2.0 V for periods of up to 20 ns. See Figure 6. Maximum DC input voltage on pin A9 is +12 V which may overshoot to 13.5V for periods up to 20 ns.
3. No more than one output may be shorted to ground at a time. Duration of the short circuit should not be greater than one second.

Stresses above those listed under "Absolute Maximum Ratings" may cause permanent damage to the device. This is a stress rating only; functional operation of the device at these or any other conditions above those indicated in the operational sections of this data sheet is not implied. Exposure of the device to absolute maximum rating conditions for extended periods may affect device reliability.

OPERATING RATINGS

Commercial (C) Devices

Ambient Temperature (T_A). 0° C to +70° C

Vcc Supply Voltages

Vcc for full voltage range. +3.0 V to 3.6 V

Operating ranges define those limits between which the functionality of the device is guaranteed.

CAPACITANCE TA = 25°C, f = 1.0 MHz

SYMBOL	PARAMETER	MIN.	TYP	MAX.	UNIT	CONDITIONS
CIN1	Input Capacitance			8	pF	VIN = 0V
CIN2	Control Pin Capacitance			12	pF	VIN = 0V
COUT	Output Capacitance			12	pF	VOUT = 0V

TABLE 8. DC CHARACTERISTICS TA = 0°C to 70°C, VCC = 3.0V~3.6V

Symbol	PARAMETER	MX26LV800T/B			UNIT	CONDITIONS
		MIN.	TYP	MAX.		
ILI	Input Leakage Current		± 1	± 3	uA	VIN = VSS to VCC
ILIT	A9 Input Leakage Current		35	200	uA	VCC=VCC max; A9=12V
ILO	Output Leakage Current			± 1	uA	VOUT = VSS to VCC, VCC=VCC max
ICC1	VCC Active Read Current		20	30	mA	CE#=VIL, @5MHz
			8	14	mA	OE#=VIH @1MHz
ICC2	VCC Active write Current		26	30	mA	CE#=VIL, OE#=VIH
ICC3	VCC Standby Current		30	100	uA	CE#; RESET#=VCC±0.3V
ICC4	VCC Standby Current During Reset		30	100	uA	RESET#=VSS ± 0.3V
VIL	Input Low Voltage (Note 1)	-0.5		0.8	V	
VIH	Input High Voltage	0.7xVCC		VCC+0.3	V	
VID	Voltage for Automatic Select	11		12	V	VCC=3.3V
VOL	Output Low Voltage			0.45	V	IOL = 4.0mA, VCC= VCC min
VOH1	Output High Voltage (TTL)	0.85xVCC				IOH = -2mA, VCC=VCC min
VOH2	Output High Voltage (CMOS)	VCC-0.4				IOH = -100uA, VCC min

NOTES:

- VIL min. = -1.0V for pulse width is equal to or less than 50 ns.
VIL min. = -2.0V for pulse width is equal to or less than 20 ns.
- VIH max. = VCC + 1.5V for pulse width is equal to or less than 20 ns
If VIH is over the specified maximum value, read operation cannot be guaranteed.
- Automatic sleep mode enable the low power mode when addresses remain stable for tACC +30ns.



AC CHARACTERISTICS TA = 0°C to 70°C, VCC = 3.0V~3.6V

TABLE 9. READ OPERATIONS

SYMBOL PARAMETER		26LV800T/B-55		26LV800T/B-70		UNIT	CONDITIONS
		MIN.	MAX.	MIN.	MAX.		
tRC	Read Cycle Time (Note 1)	55		70		ns	
tACC	Address to Output Delay		55		70	ns	CE#=OE#=VIL
tCE	CE# to Output Delay		55		70	ns	OE#=VIL
tOE	OE# to Output Delay		25		30	ns	CE#=VIL
tDF	OE# High to Output Float (Note1)	0	25	0	25	ns	CE#=VIL
tOEH	Output	Read	0	0		ns	
	Enable	Toggle and	10	10		ns	
	Hold Time	Data# Polling					
tOH	Address to Output hold	0		0		ns	CE#=OE#=VIL

TEST CONDITIONS:

- Input pulse levels: 0V/3.0V.
- Input rise and fall times is equal to or less than 5ns.
- Output load: 1 TTL gate + 100pF (Including scope and jig), for 26LV800T/B-70. 1 TTL gate + 30pF (Including scope and jig) for 26LV800T/B-55.
- Reference levels for measuring timing: 1.5V.

NOTE:

1. Not 100% tested.
2. tDF is defined as the time at which the output achieves the open circuit condition and data is no longer driven.

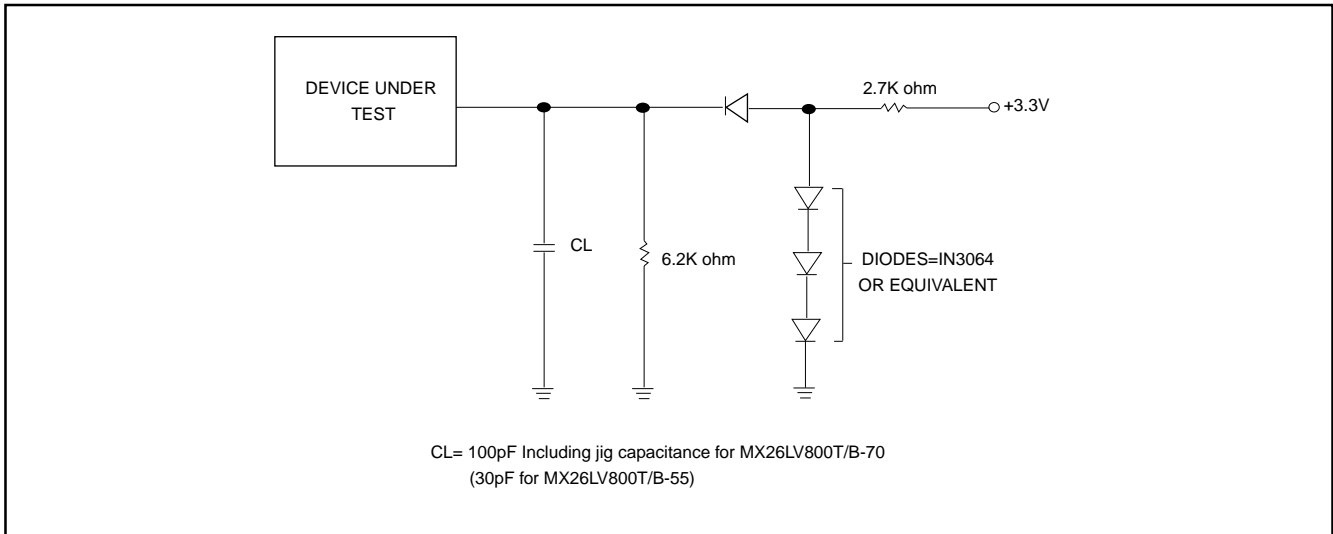
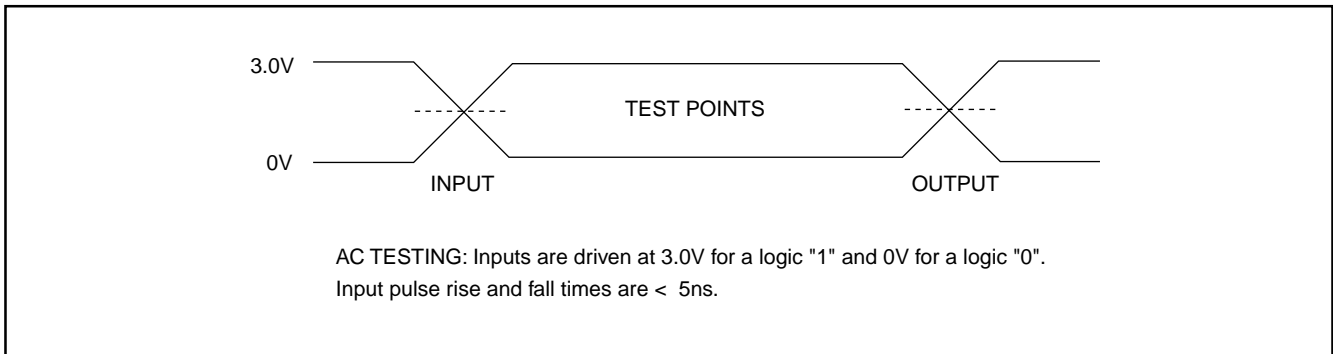
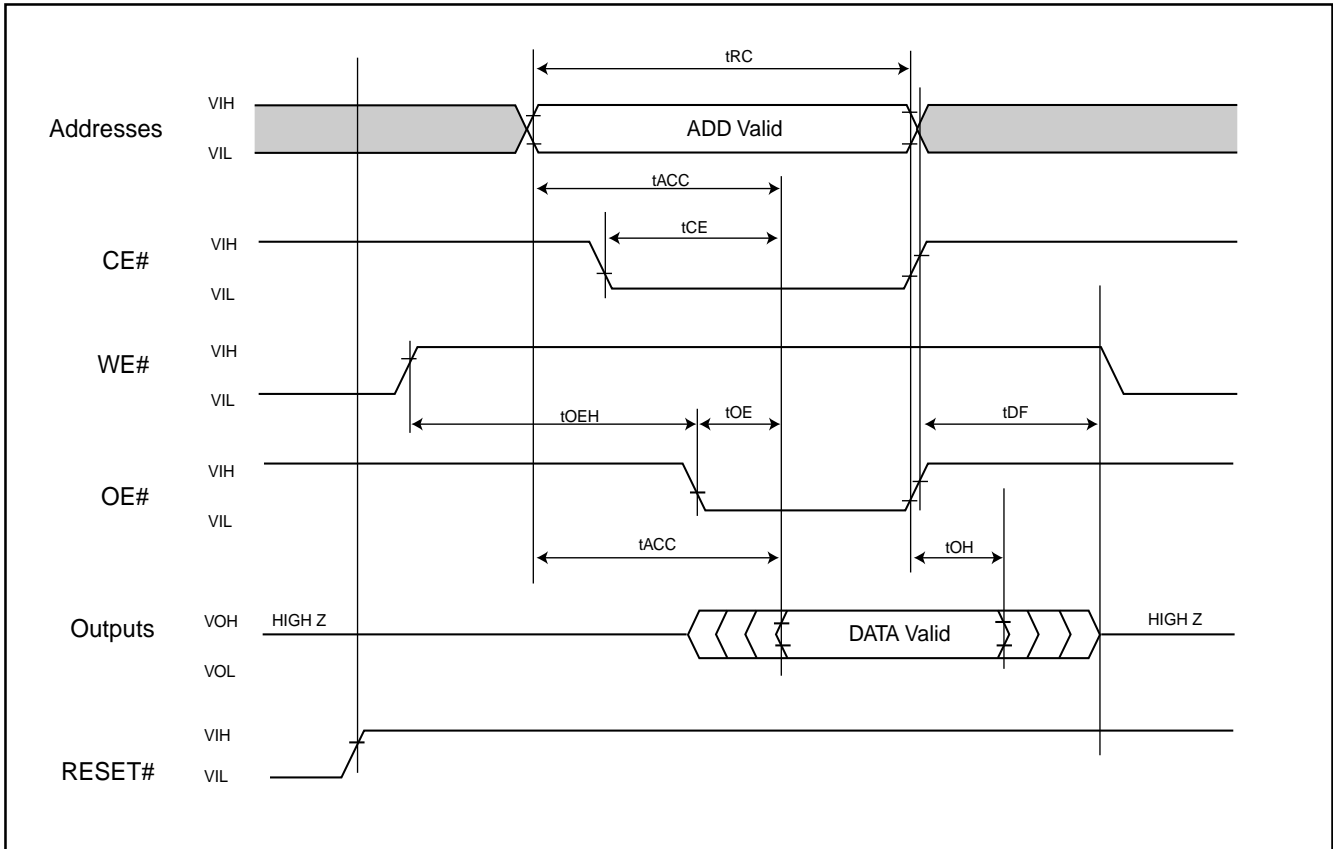
SWITCHING TEST CIRCUITS

SWITCHING TEST WAVEFORMS


FIGURE 1. READ TIMING WAVEFORMS


**AC CHARACTERISTICS TA = 0°C to 70°C, VCC = 3.0V~3.6V****TABLE 10. Erase/Program Operations**

SYMBOL	PARAMETER	<u>26LV800T/B-55</u>		<u>26LV800T/B-70</u>		UNIT
		MIN.	MAX.	MIN.	MAX.	
tWC	Write Cycle Time (Note 1)	55		70		ns
tAS	Address Setup Time	0		0		ns
tAH	Address Hold Time	45		45		ns
tDS	Data Setup Time	35		35		ns
tDH	Data Hold Time	0		0		ns
tOES	Output Enable Setup Time	0		0		ns
tGHWL	Read Recovery Time Before Write (OE# High to WE# Low)	0		0		ns
tCS	CE# Setup Time	0		0		ns
tCH	CE# Hold Time	0		0		ns
tWP	Write Pulse Width	35		35		ns
tWPH	Write Pulse Width High	30		30		ns
tWHWH1	Programming Operation (Note 2) (Byte/Word program time)	55/70(TYP.)		55/70(TYP.)		us
tWHWH2	Sector Erase Operation (Note 2)	2.4(TYP.)		2.4(TYP.)		sec
tVCS	VCC Setup Time (Note 1)	50		50		us
tRB	Recovery Time from RY/BY#	0		0		ns
tBUSY	Program/Erase Valid to RY/BY# Delay		90		90	ns
tBAL	Sector Address Load Time		50		50	us

NOTES:

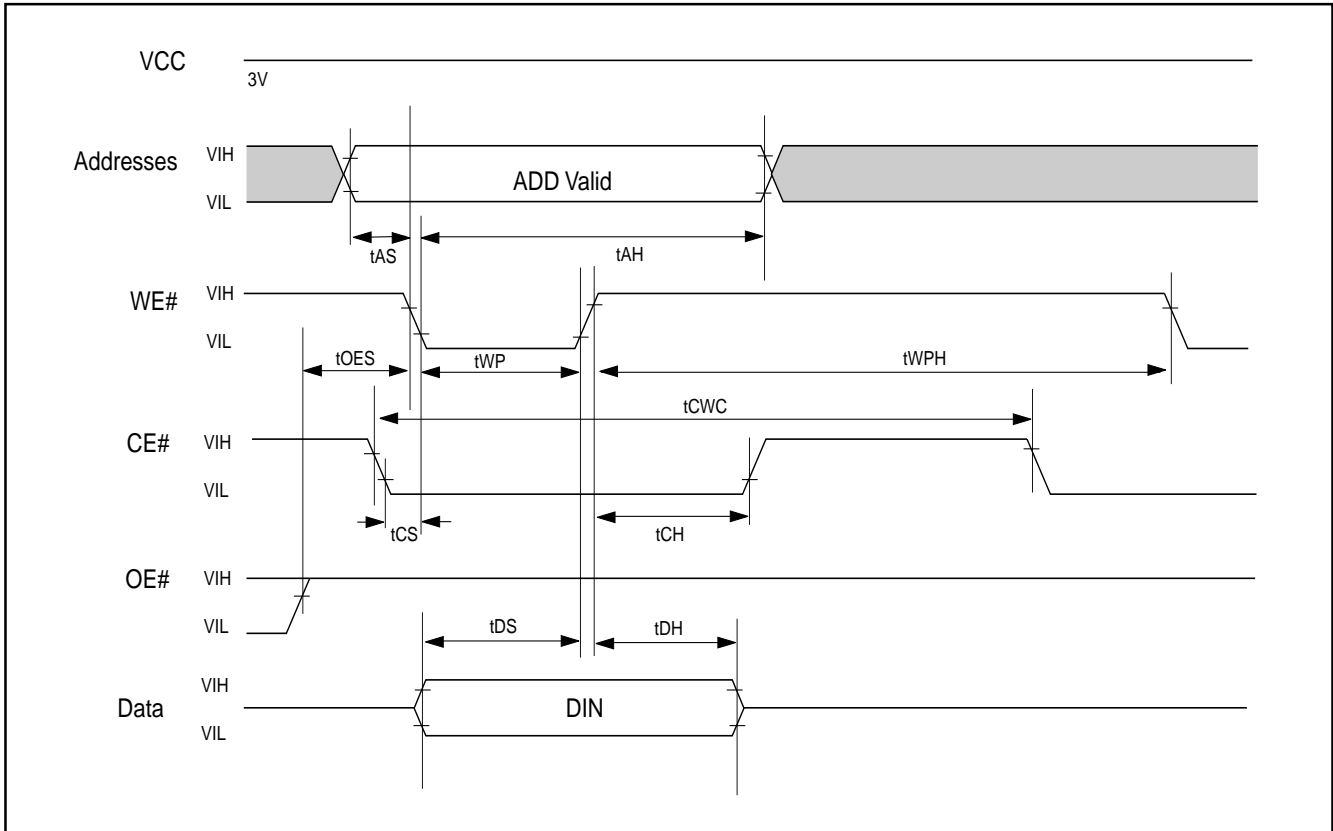
1. Not 100% tested.
2. See the "Erase and Programming Performance" section for more information.

**AC CHARACTERISTICS TA = 0°C to 70°C, VCC = 3.0V~3.6V****TABLE 11. Alternate CE# Controlled Erase/Program Operations**

SYMBOL	PARAMETER	<u>26LV800T/B-55</u>		<u>26LV800T/B-70</u>		UNIT
		MIN.	MAX.	MIN.	MAX.	
tWC	Write Cycle Time (Note 1)	55		70		ns
tAS	Address Setup Time	0		0		ns
tAH	Address Hold Time	45		45		ns
tDS	Data Setup Time	35		35		ns
tDH	Data Hold Time	0		0		ns
tOES	Output Enable Setup Time	0		0		ns
tGHEL	Read Recovery Time Before Write	0		0		ns
tWS	WE# Setup Time	0		0		ns
tWH	WE# Hold Time	0		0		ns
tCP	CE# Pulse Width	35		35		ns
tCPH	CE# Pulse Width High	30		30		ns
tWHWH1	Programming Operation(note2)	Byte	55(Typ.)		55(Typ.)	us
		Word	70(Typ.)		70(Typ.)	us
tWHWH2	Sector Erase Operation (note2)		2.4(Typ.)		2.4(Typ.)	sec

NOTE:

1. Not 100% tested.
2. See the "Erase and Programming Performance" section for more information.

FIGURE 2. COMMAND WRITE TIMING WAVEFORM


AUTOMATIC PROGRAMMING TIMING WAVEFORM

One byte data is programmed. Verify in fast algorithm and additional verification by external control are not required because these operations are executed automatically by internal control circuit. Programming completion can be verified by DATA# polling and toggle bit check-

ing after automatic programming starts. Device outputs DATA# during programming and DATA# after programming on Q7. (Q6 is for toggle bit; see toggle bit, DATA# polling, timing waveform)

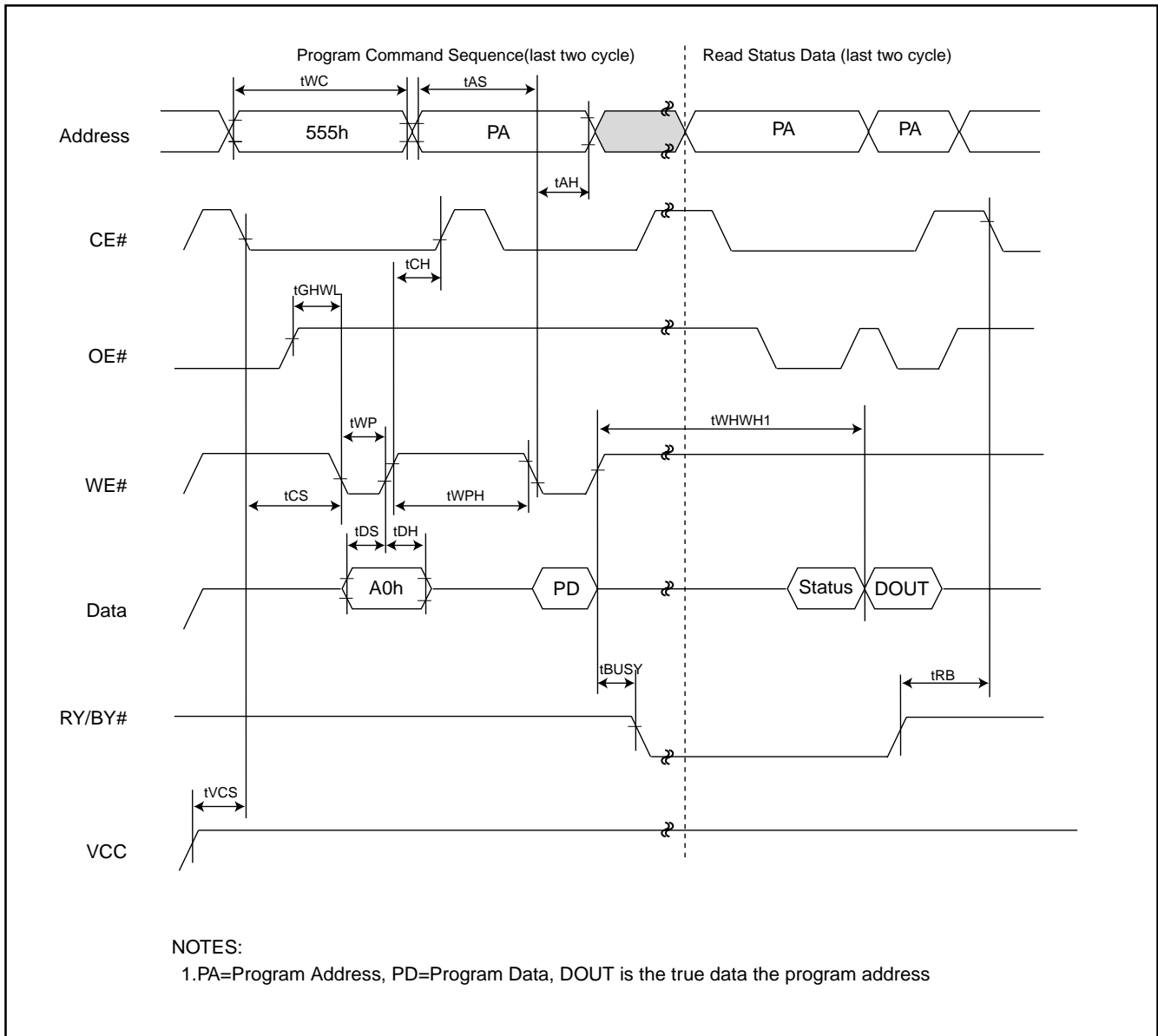
FIGURE 3. AUTOMATIC PROGRAMMING TIMING WAVEFORM


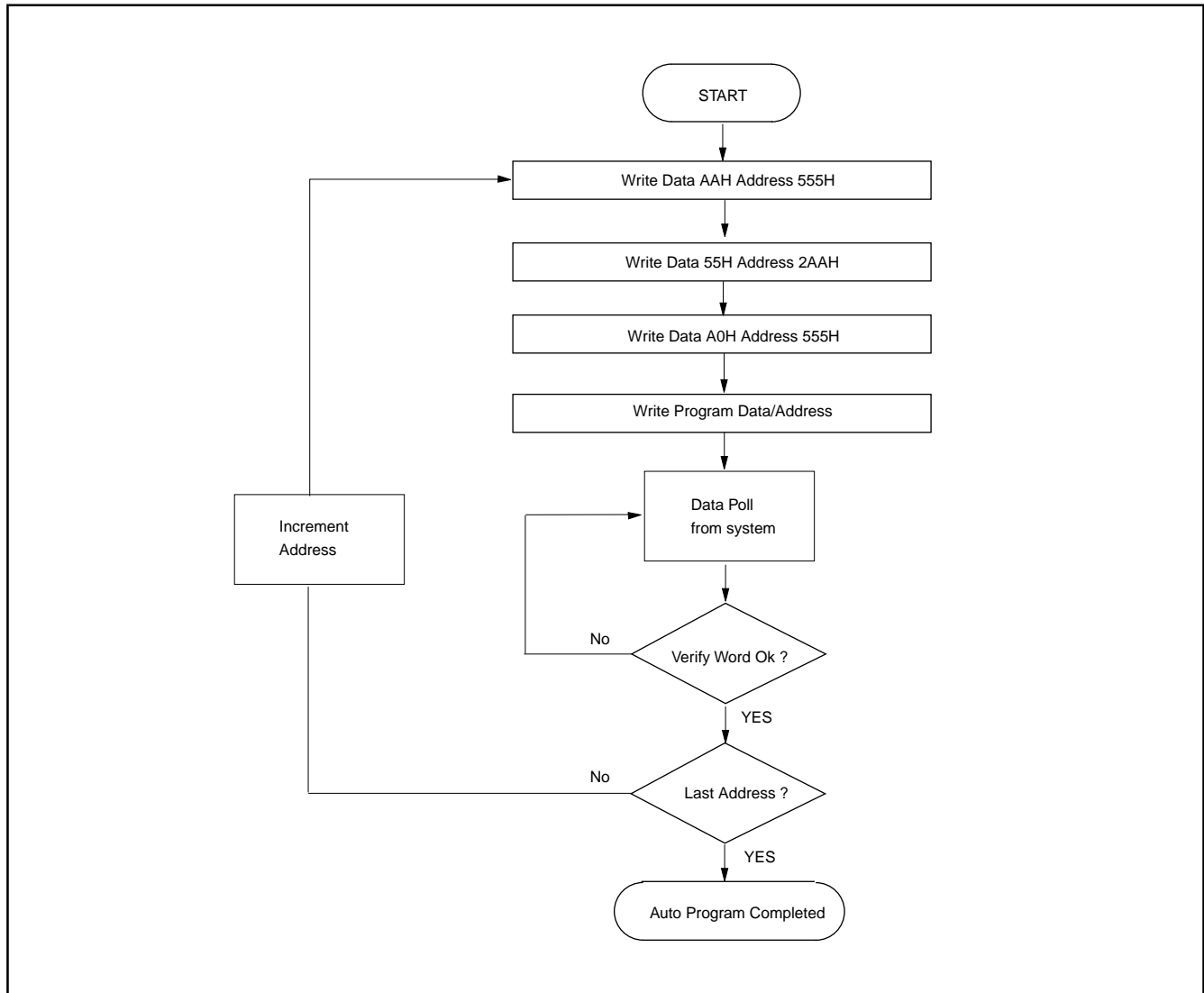
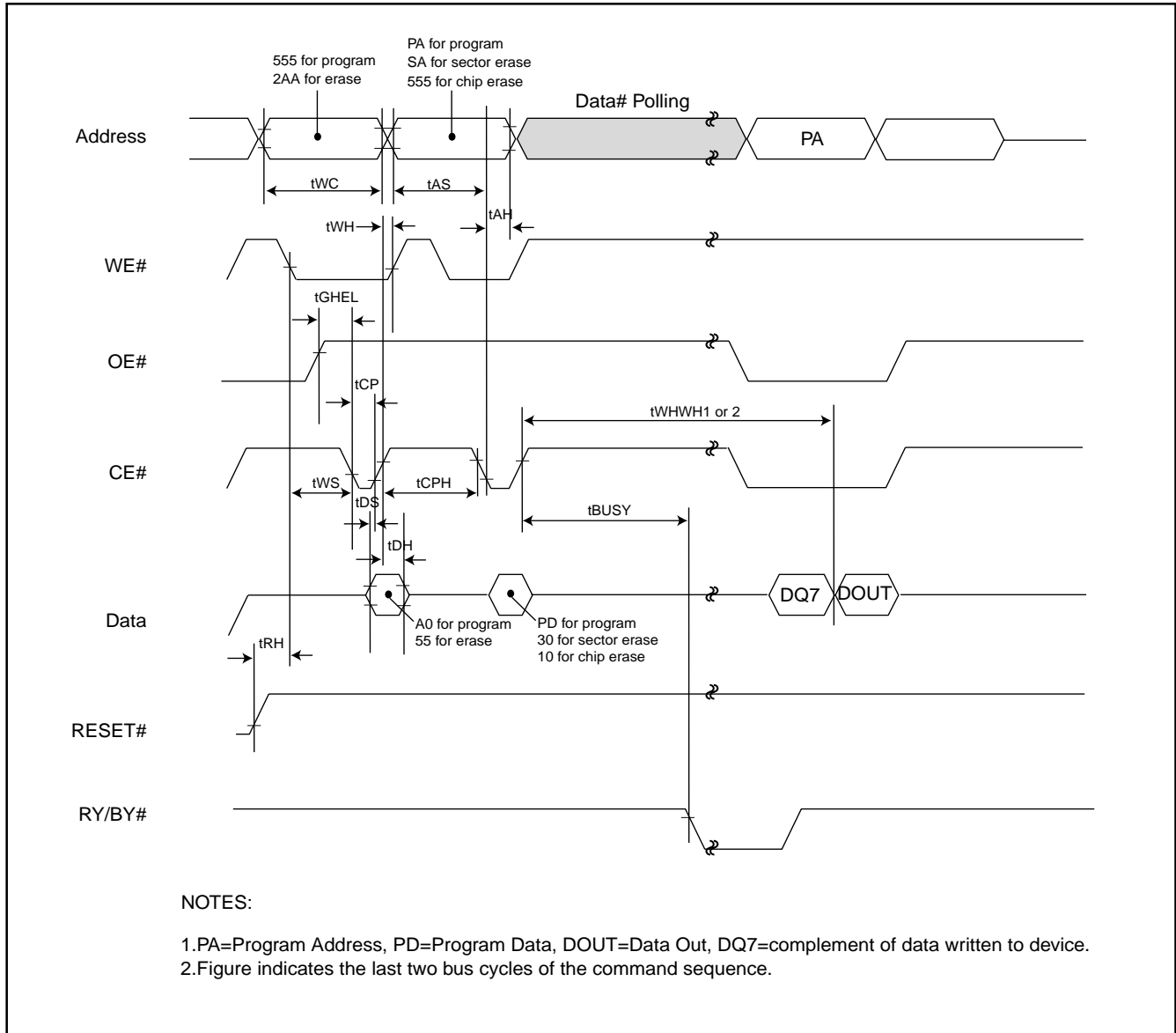
FIGURE 4. AUTOMATIC PROGRAMMING ALGORITHM FLOWCHART

FIGURE 5. CE# CONTROLLED PROGRAM TIMING WAVEFORM


AUTOMATIC CHIP ERASE TIMING WAVEFORM

All data in chip are erased. External erase verification is not required because data is verified automatically by internal control circuit. Erasure completion can be verified by DATA# polling and toggle bit checking after auto-

matic erase starts. Device outputs 0 during erasure and 1 after erasure on Q7. (Q6 is for toggle bit; see toggle bit, DATA# polling, timing waveform)

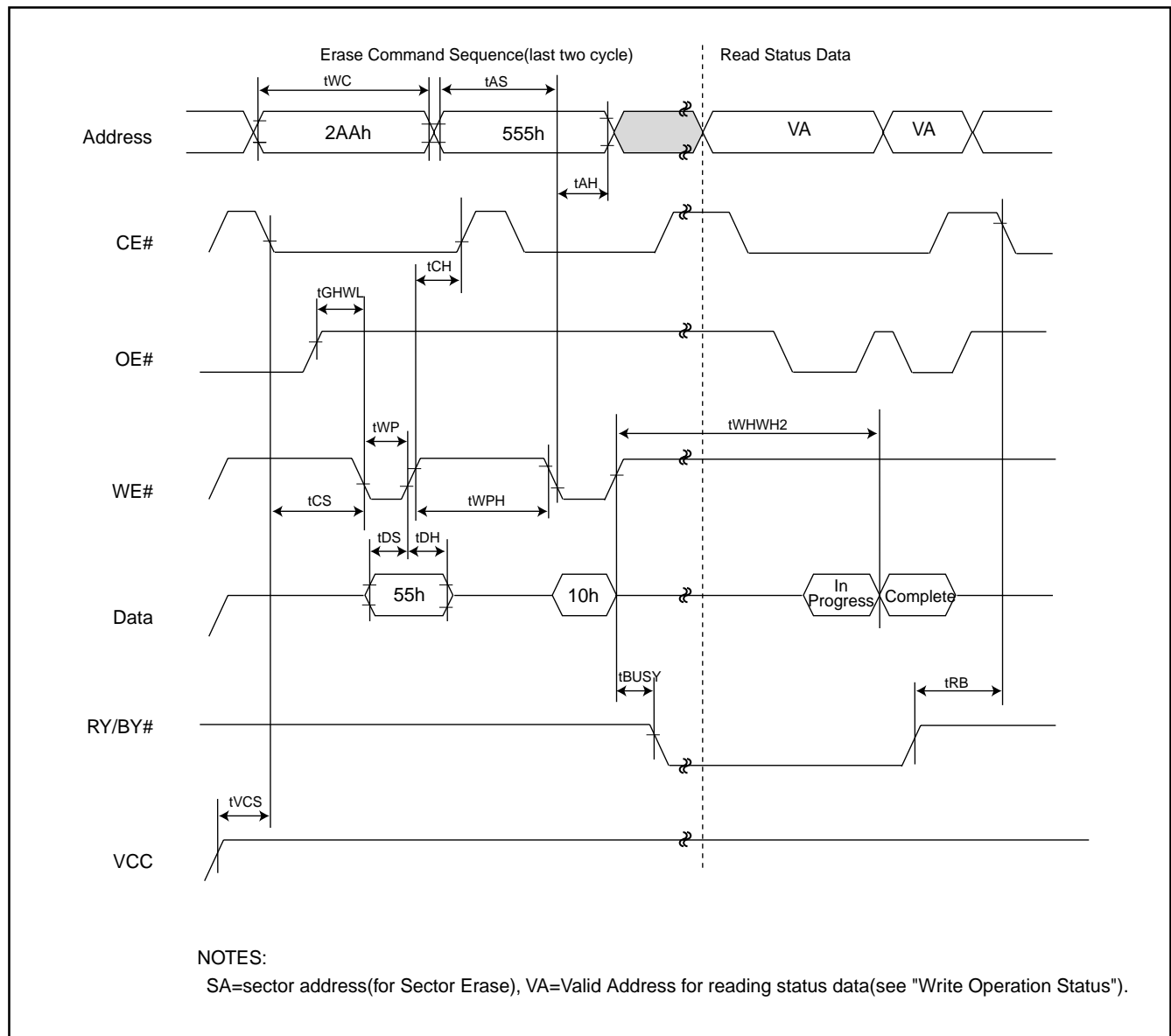
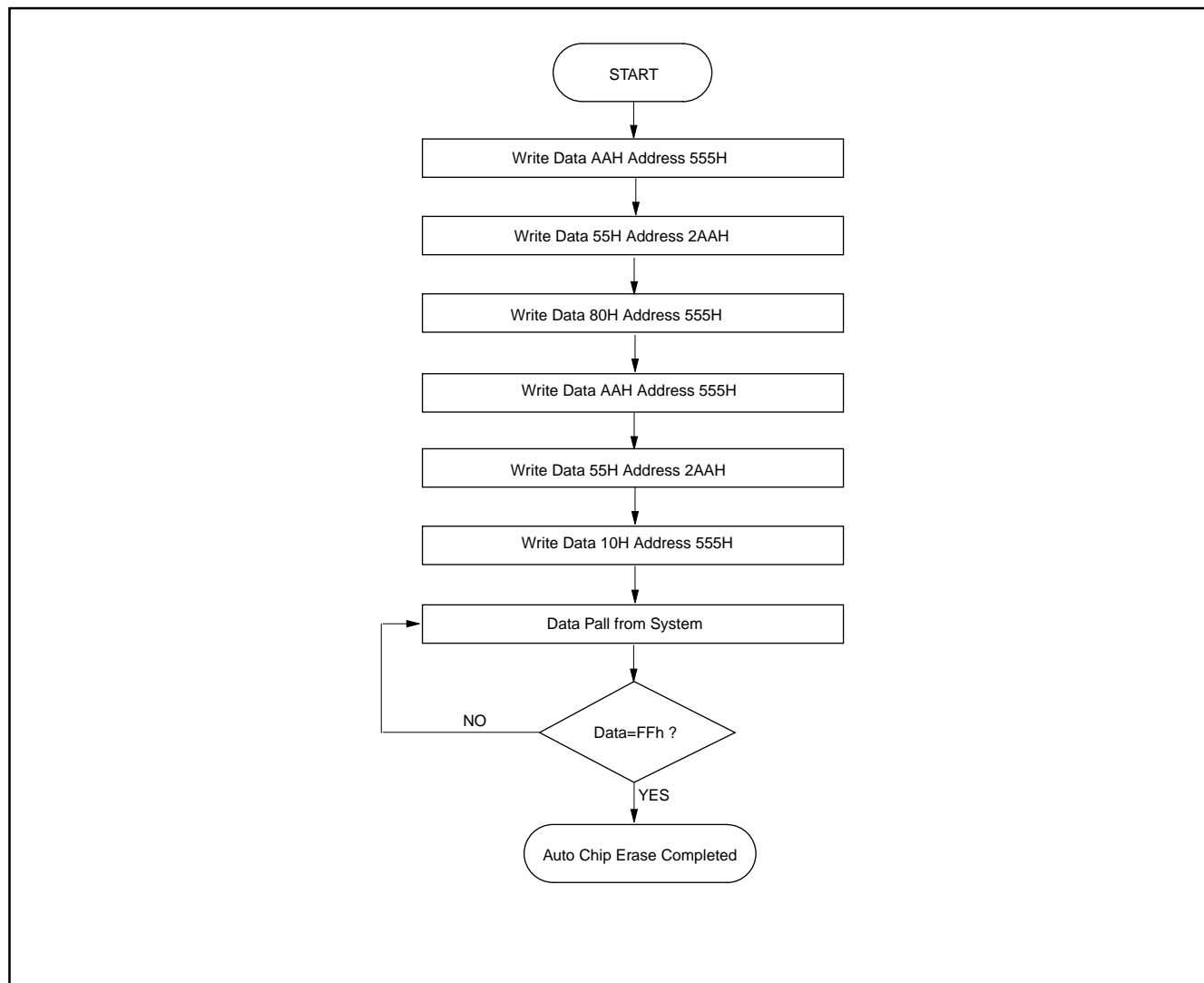
FIGURE 6. AUTOMATIC CHIP ERASE TIMING WAVEFORM


FIGURE 7. AUTOMATIC CHIP ERASE ALGORITHM FLOWCHART

AUTOMATIC SECTOR ERASE TIMING WAVEFORM

Sector indicated by A12 to A18 are erased. External erase verify is not required because data are verified automatically by internal control circuit. Erasure completion can be verified by DATA# polling and toggle bit check-

ing after automatic erase starts. Device outputs 0 during erasure and 1 after erasure on Q7. (Q6 is for toggle bit; see toggle bit, DATA# polling, timing waveform)

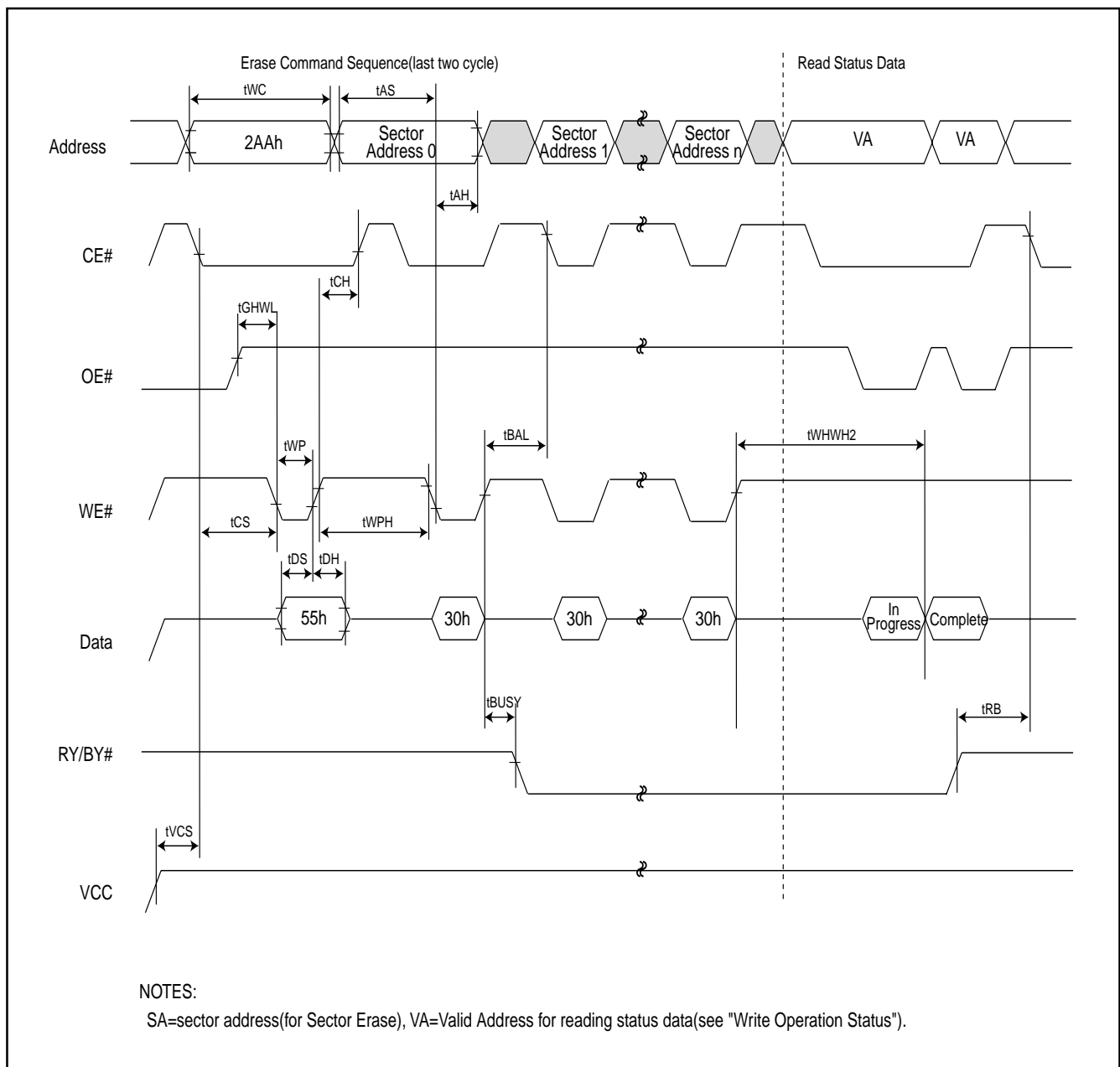
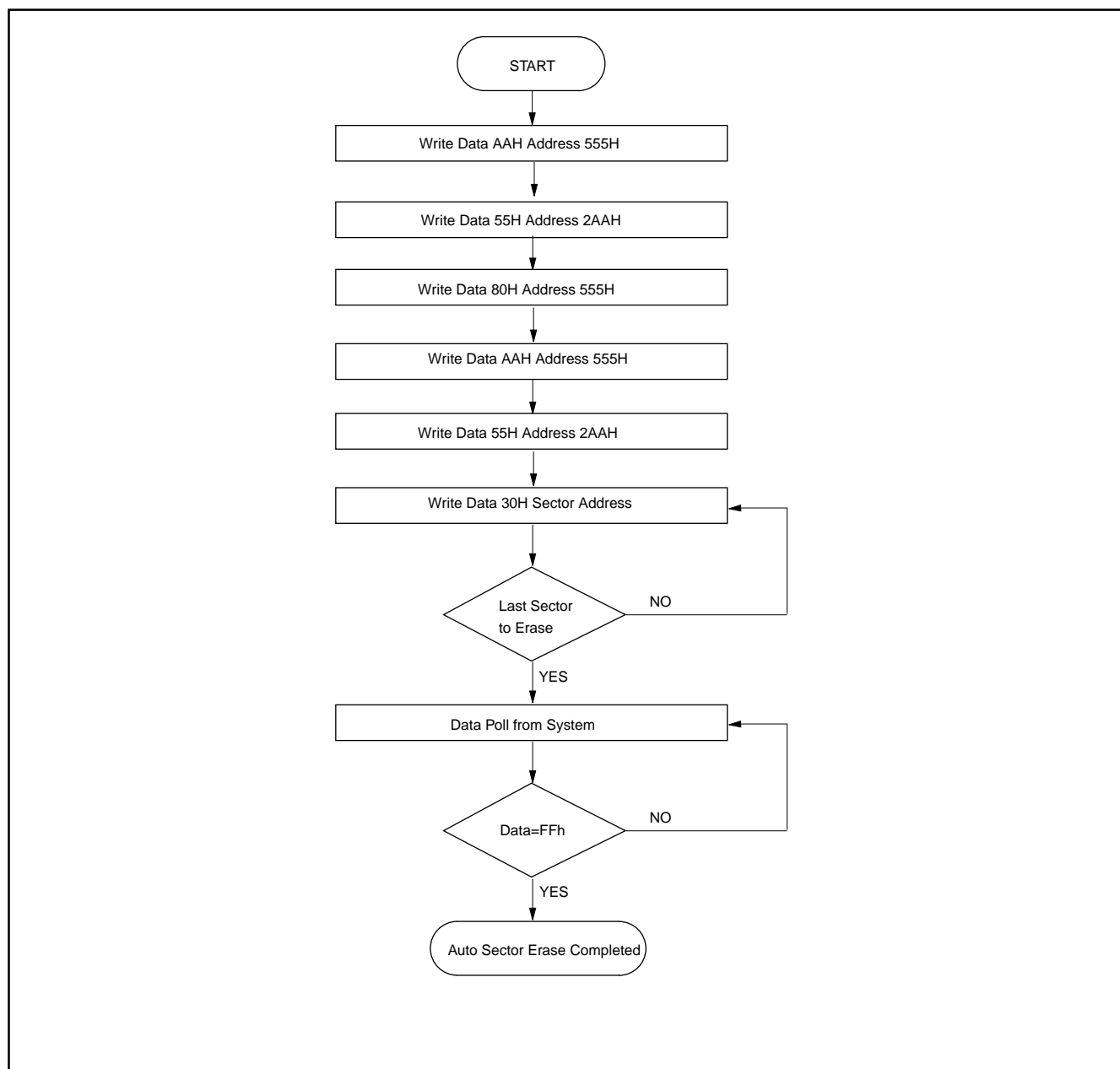
FIGURE 8. AUTOMATIC SECTOR ERASE TIMING WAVEFORM


FIGURE 9. AUTOMATIC SECTOR ERASE ALGORITHM FLOWCHART



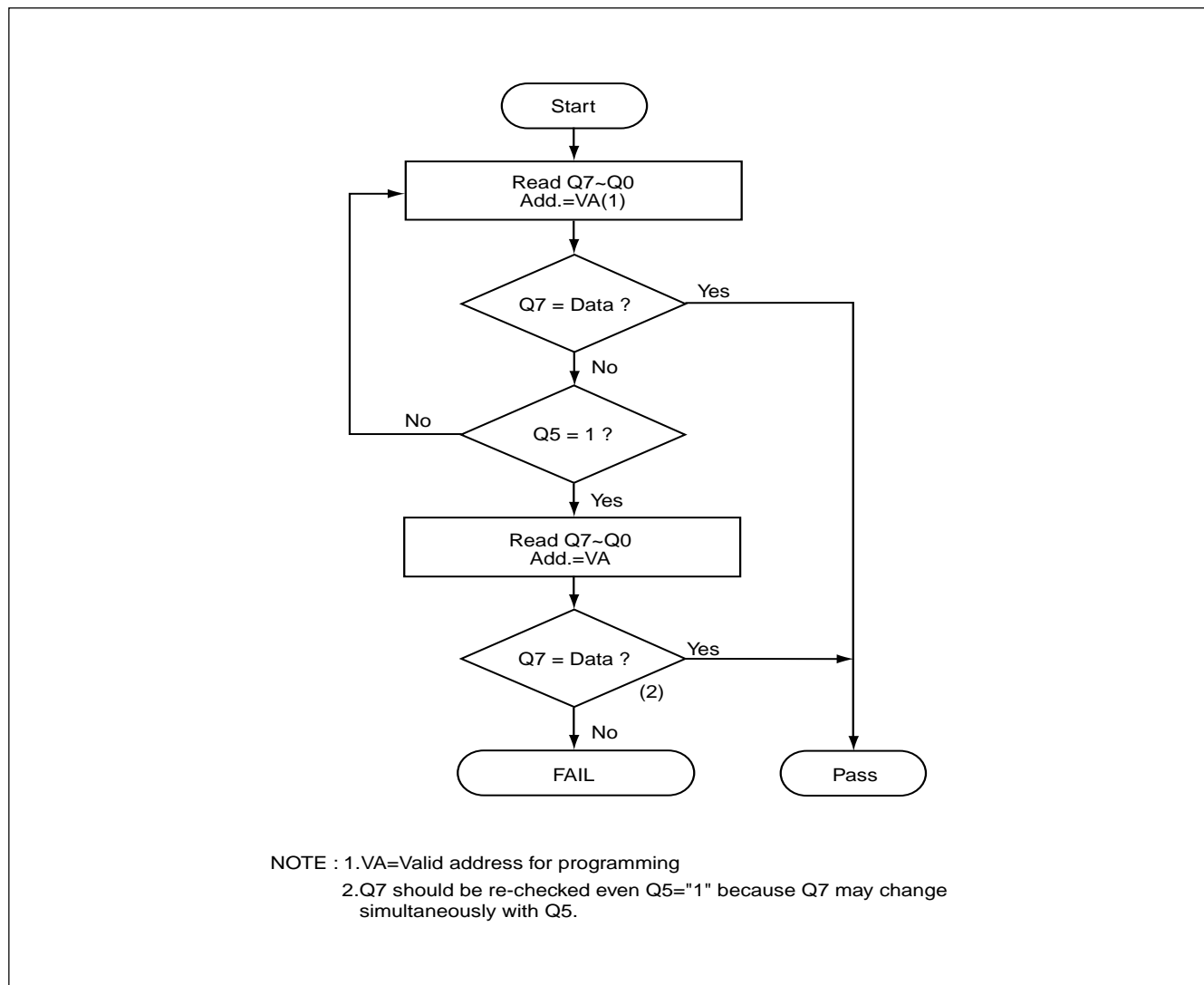
WRITE OPERATION STATUS
FIGURE 10. DATA# POLLING ALGORITHM


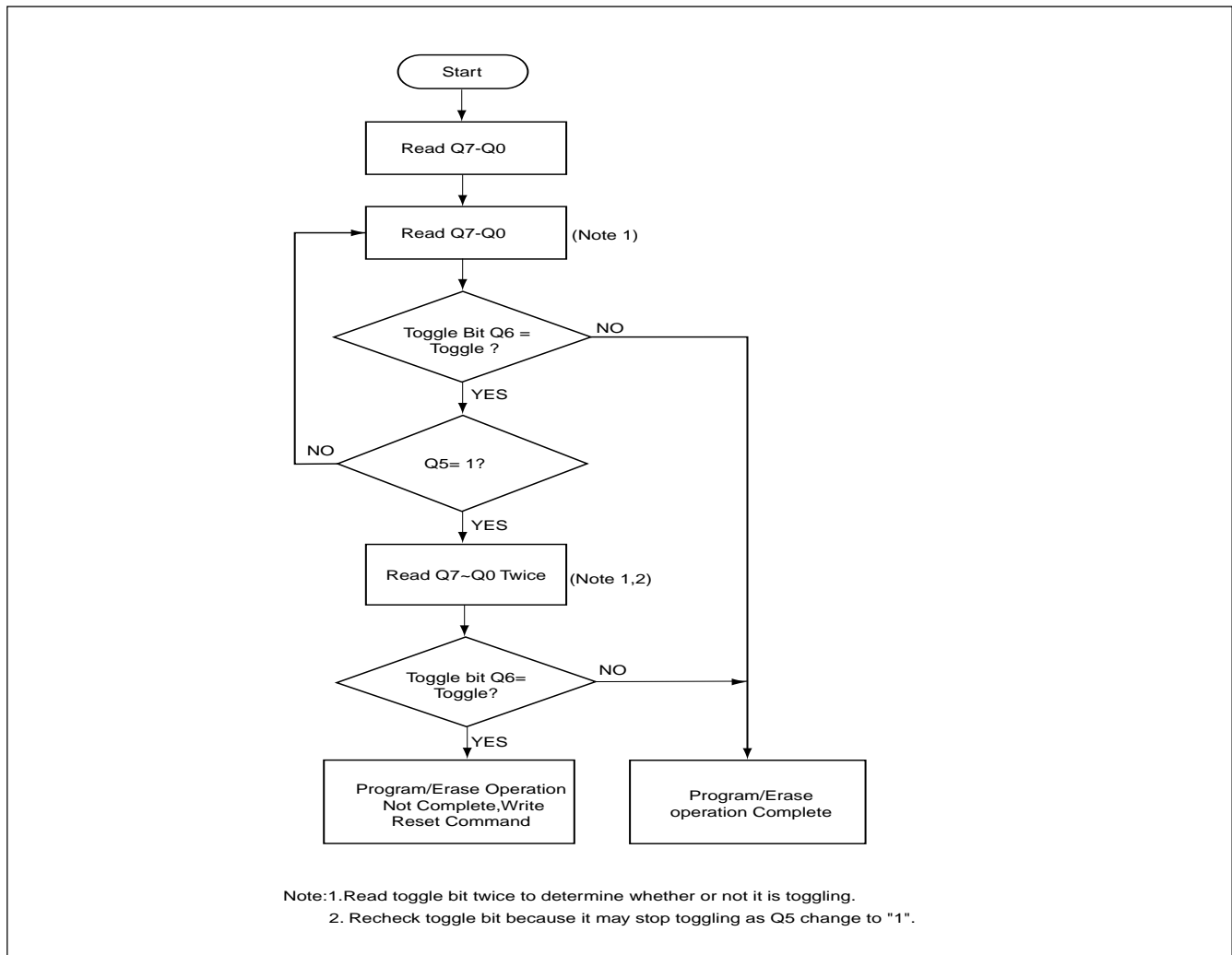
FIGURE 11. TOGGLE BIT ALGORITHM


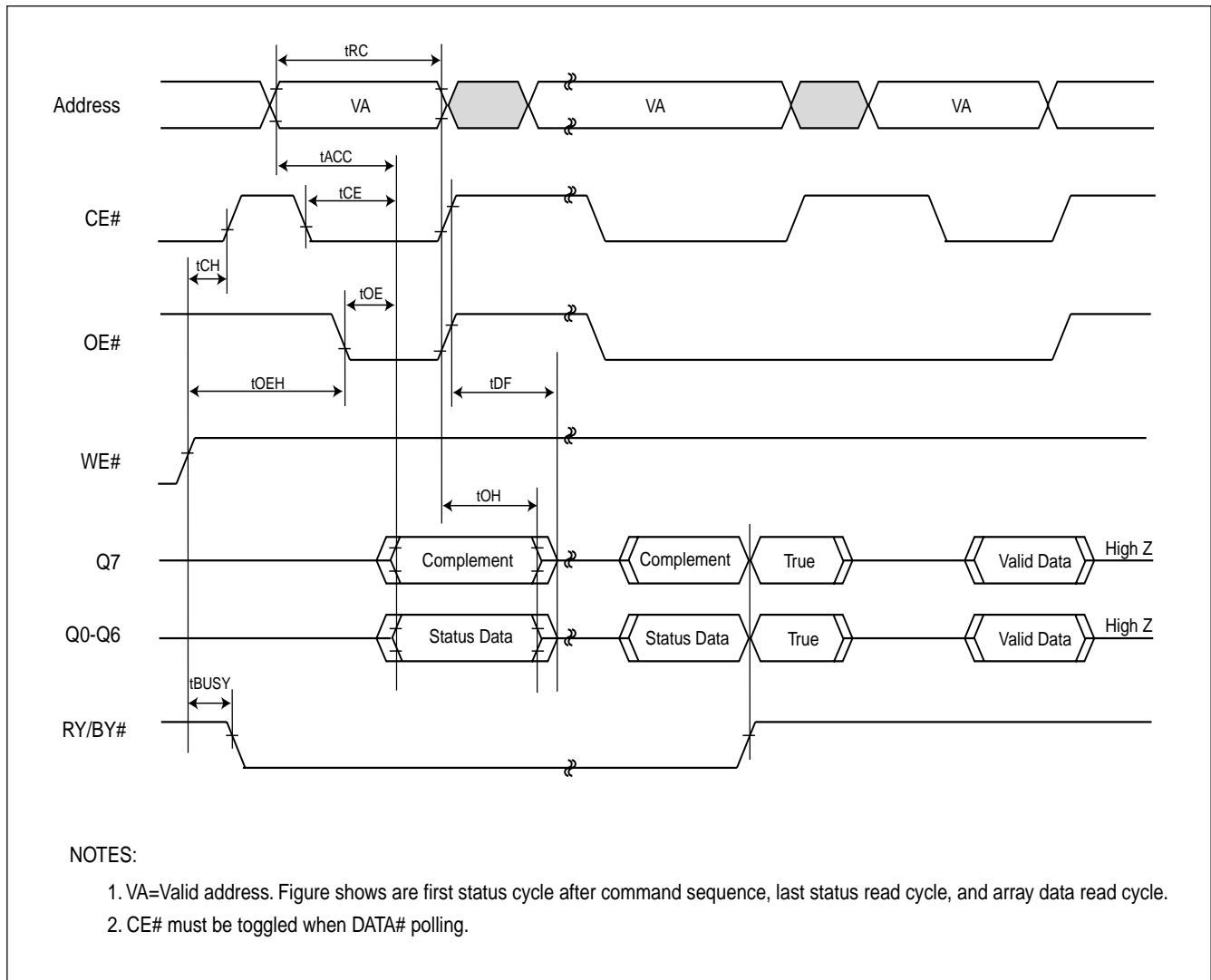
FIGURE 12. Data# Polling Timings (During Automatic Algorithms)


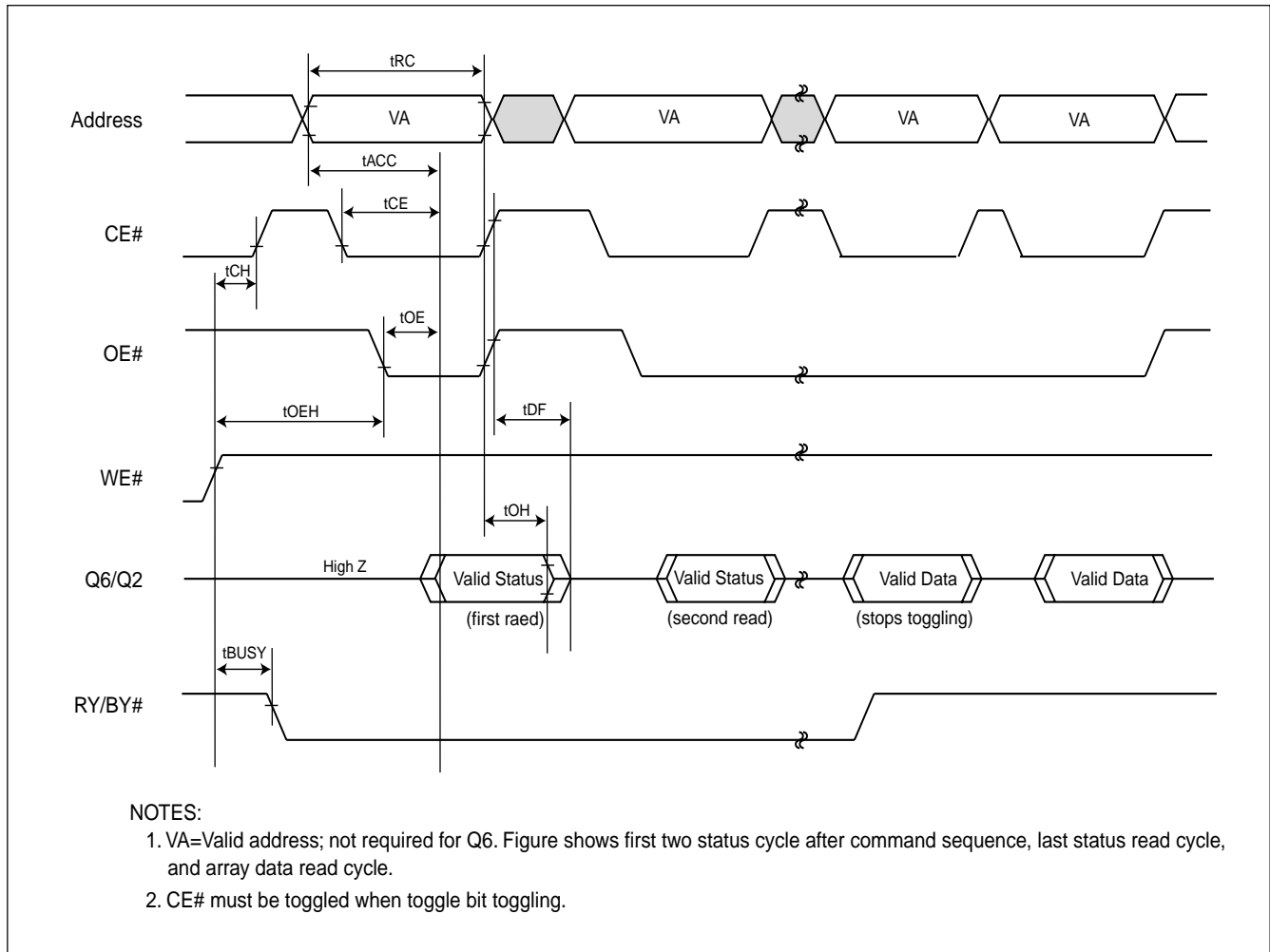
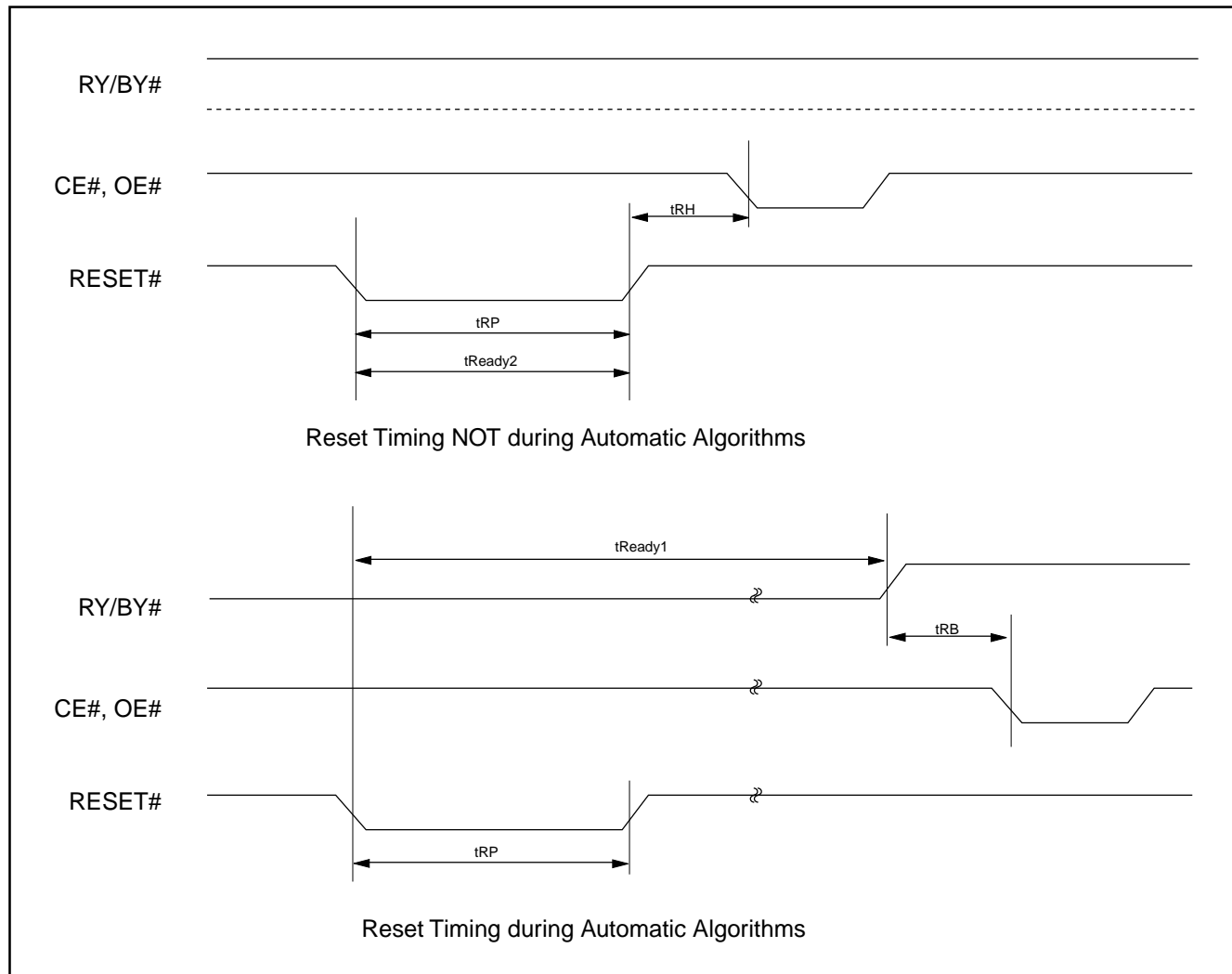
FIGURE 13. Toggle Bit Timings (During Automatic Algorithms)


TABLE 12. AC CHARACTERISTICS

Parameter Std	Description	Test Setup	All Speed Options	Unit
tREADY1	RESET# PIN Low (During Automatic Algorithms) to Read or Write (See Note)	MAX	20	us
tREADY2	RESET# PIN Low (NOT During Automatic Algorithms) to Read or Write (See Note)	MAX	500	ns
tRP	RESET# Pulse Width (During Automatic Algorithms)	MIN	500	ns
tRH	RESET# High Time Before Read (See Note)	MIN	50	ns
tRB	RY/BY# Recovery Time (to CE#, OE# go low)	MIN	0	ns

Note: Not 100% tested

FIGURE 14. RESET# TIMING WAVEFORM


AC CHARACTERISTICS
TABLE 13. WORD/BYTE CONFIGURATION (BYTE#)

Parameter		Description		Speed Options		Unit
JEDEC	Std			-55	-70	
	tELFL/tELFH	CE# to BYTE# Switching Low or High	Max	5		ns
	tFLQZ	BYTE# Switching Low to Output HIGH Z	Max	25	25	ns
	tFHQV	BYTE# Switching High to Output Active	Min	55	70	ns

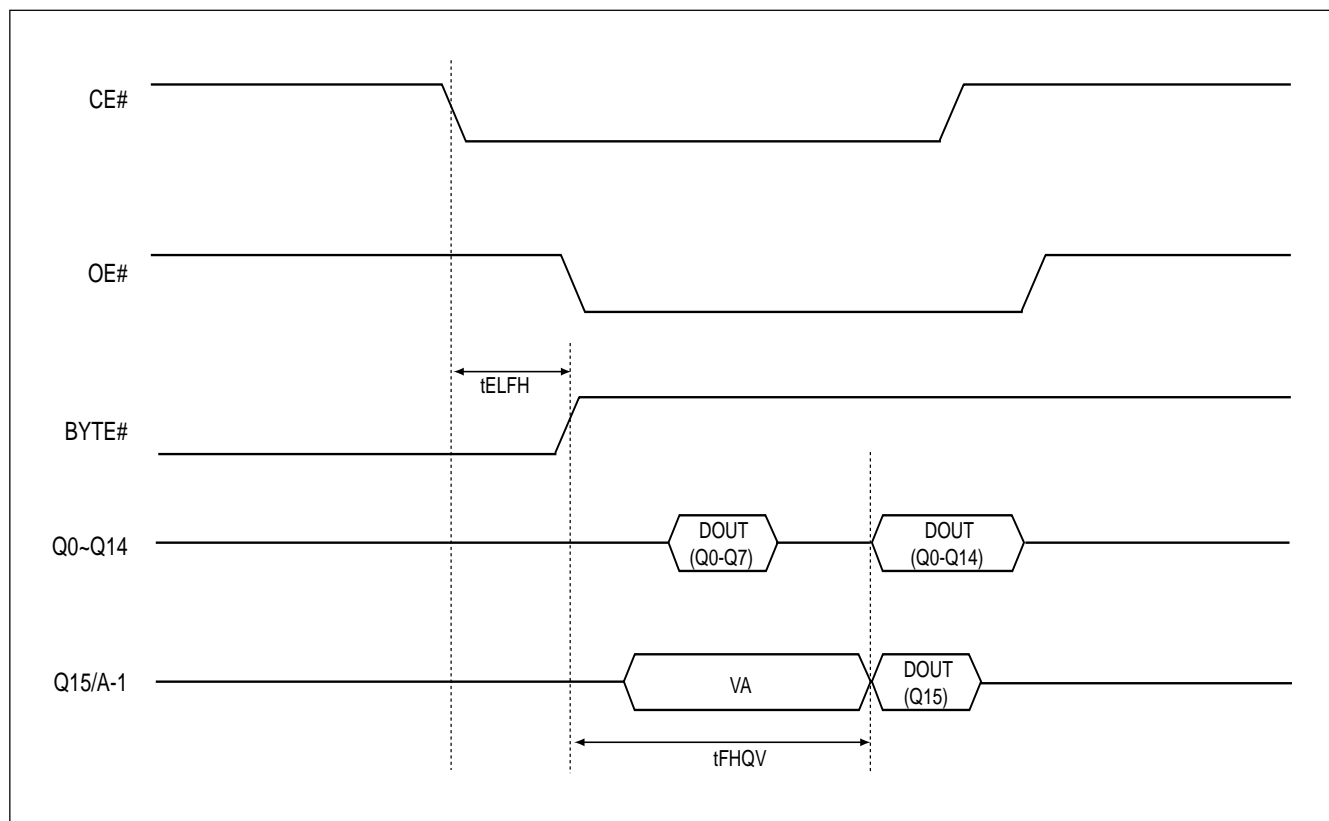
FIGURE 15. BYTE# TIMING WAVEFORM FOR READ OPERATIONS (BYTE# switching from byte mode to word mode)


FIGURE 16. BYTE# TIMING WAVEFORM FOR READ OPERATIONS (BYTE# switching from word mode to byte mode)

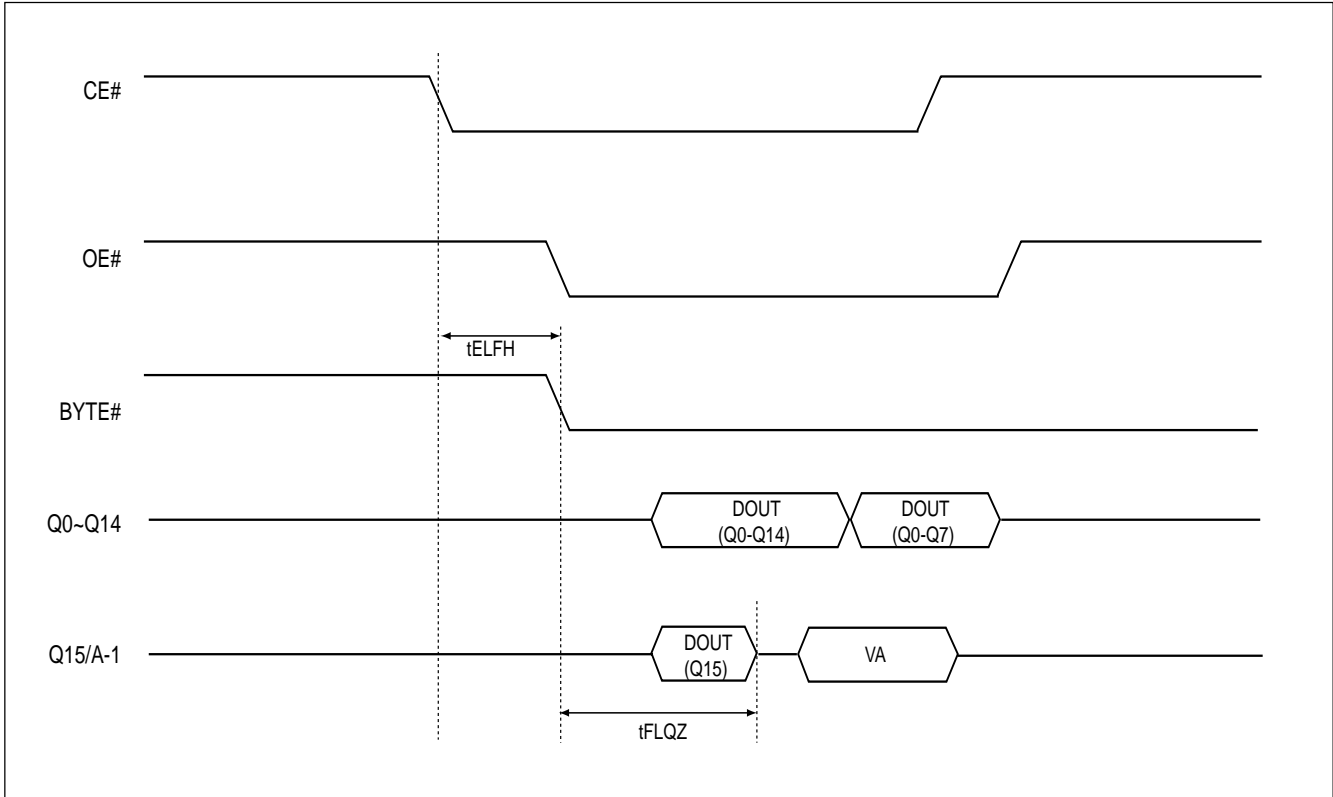


FIGURE 17. BYTE# TIMING WAVEFORM FOR PROGRAM OPERATIONS

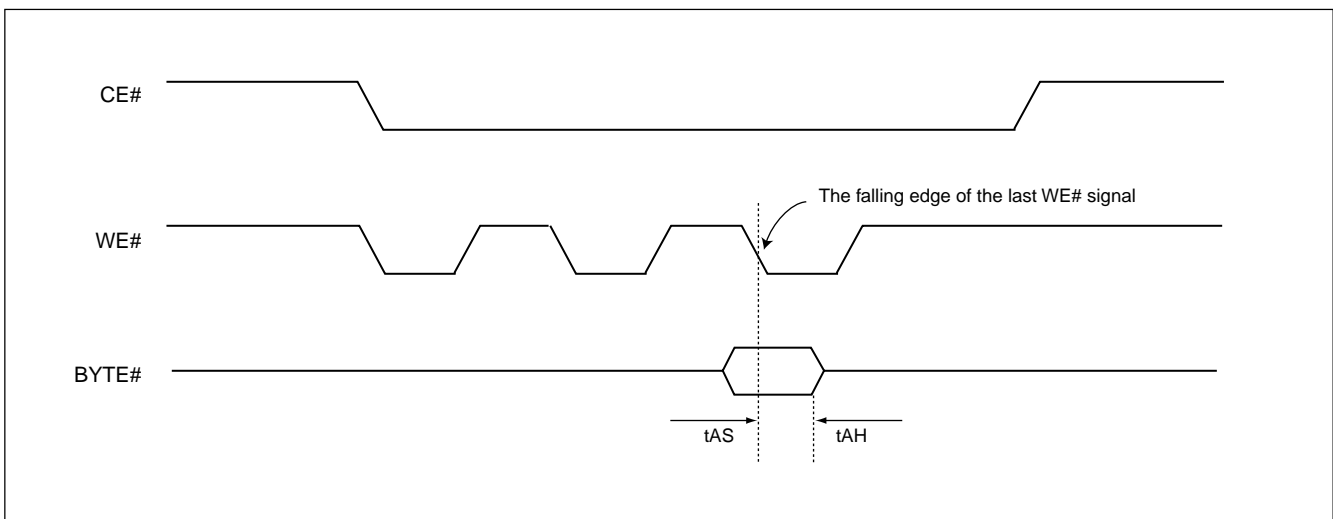


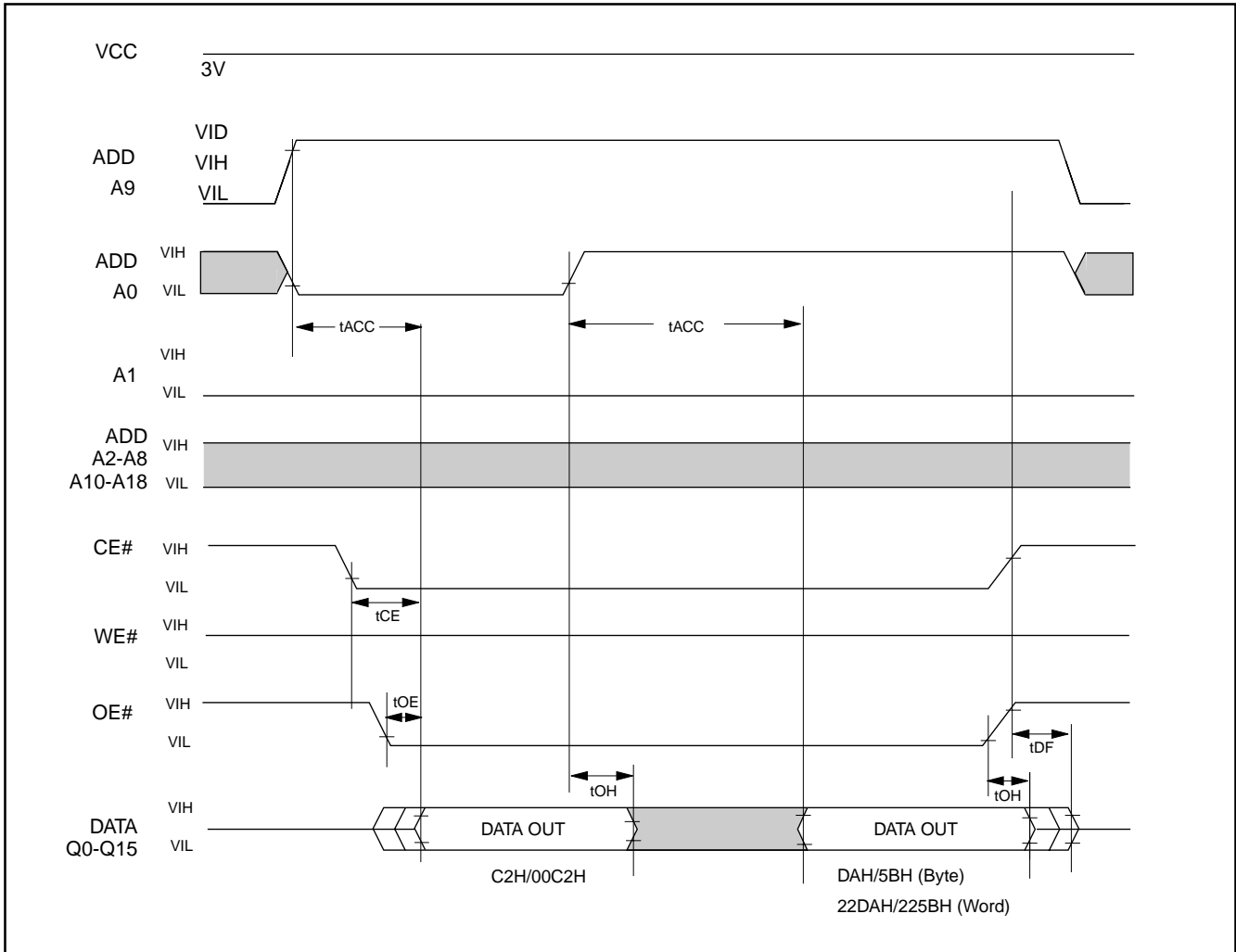
FIGURE 18. ID CODE READ TIMING WAVEFORM


TABLE 14. ERASE AND PROGRAMMING PERFORMANCE (1)

PARAMETER	LIMITS			UNITS
	MIN.	TYP. (2)	MAX. (3)	
Sector Erase Time		2.4	15	sec
Chip Erase Time		40	160	sec
Byte Programming Time		55	220	us
Word Programming Time		70	280	us
Chip Programming Time (Word/Byte Mode)		35	70	sec
Erase/Program Cycles	2K (6)			Cycles

Note:

1. Not 100% tested.
2. Typical program and erase times assume the following conditions : 25° C, 3.3V VCC. Programming spec. assume that all bits are programmed to checkerboard pattern.
3. Maximum values are measured at VCC=3.0V, worst case temperature. Maximum values are up to including 2K program/erase cycles.
4. System-level overhead is the time required to execute the command sequences for the all program command.
5. Excludes 00H programming prior to erasure. (In the pre-programming step of the embedded erase algorithm, all bits are programmed to 00H before erasure)
6. Min. erase/program cycles is under : 3.3V VCC, 25° C, checkerboard pattern conditions, and without baking process.

TABLE 15. LATCH-UP CHARACTERISTICS

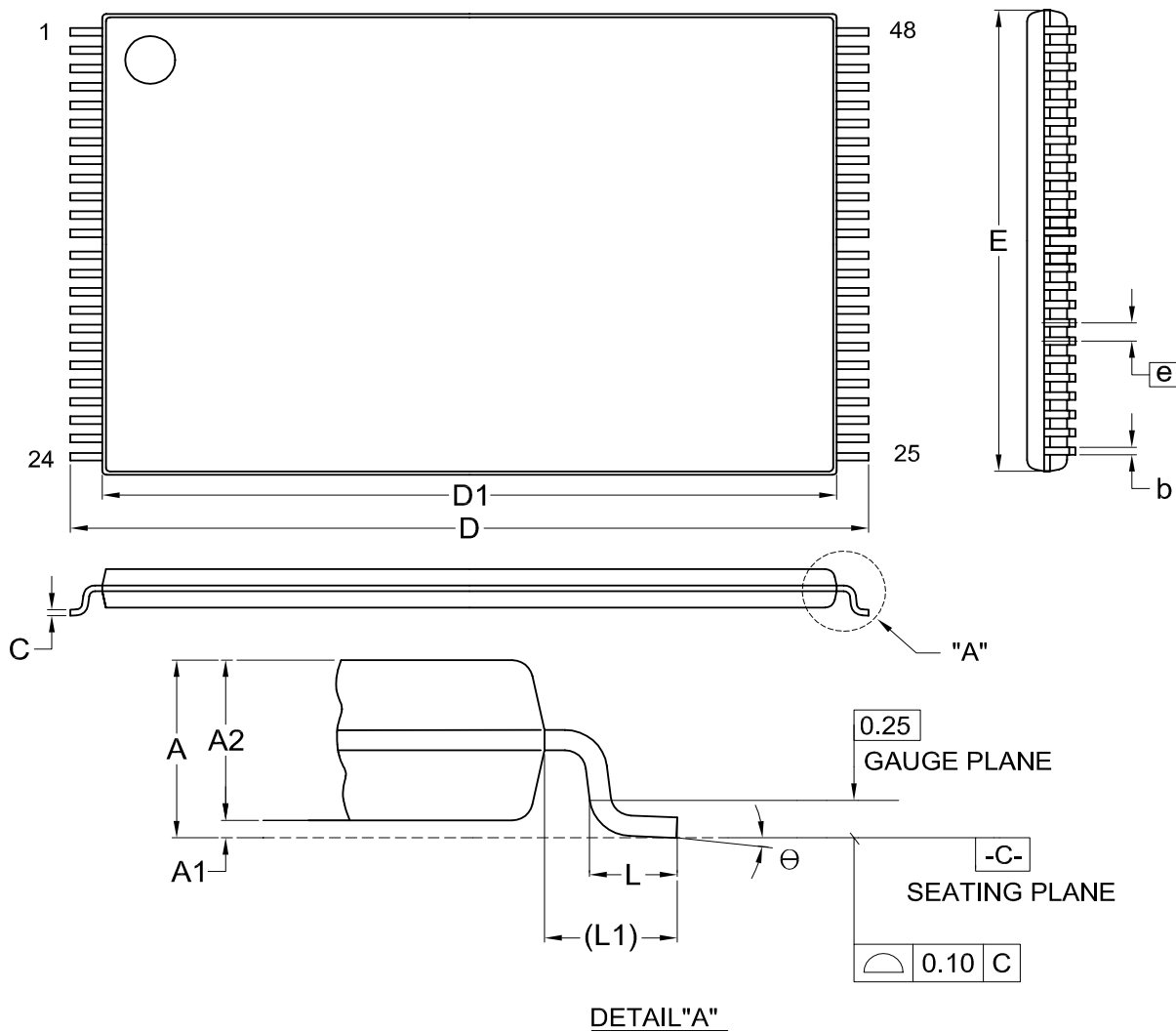
	MIN.	MAX.
Input Voltage with respect to GND on ACC, OE#, RESET#, A9	-1.0V	12V
Input Voltage with respect to GND on all power pins, Address pins, CE# and WE#	-1.0V	VCC + 1.0V
Input Voltage with respect to GND on all I/O pins	-1.0V	VCC + 1.0V
Current	-100mA	+100mA
Includes all pins except VCC. Test conditions: VCC = 3.0V, one pin at a time.		



ORDERING INFORMATION

PLASTIC PACKAGE

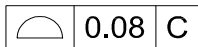
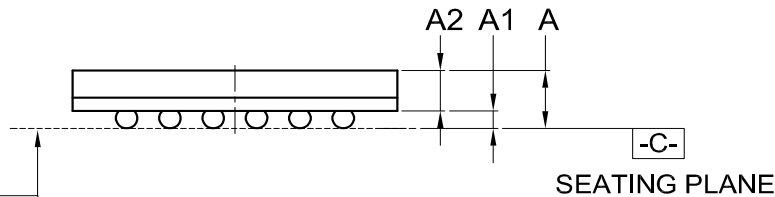
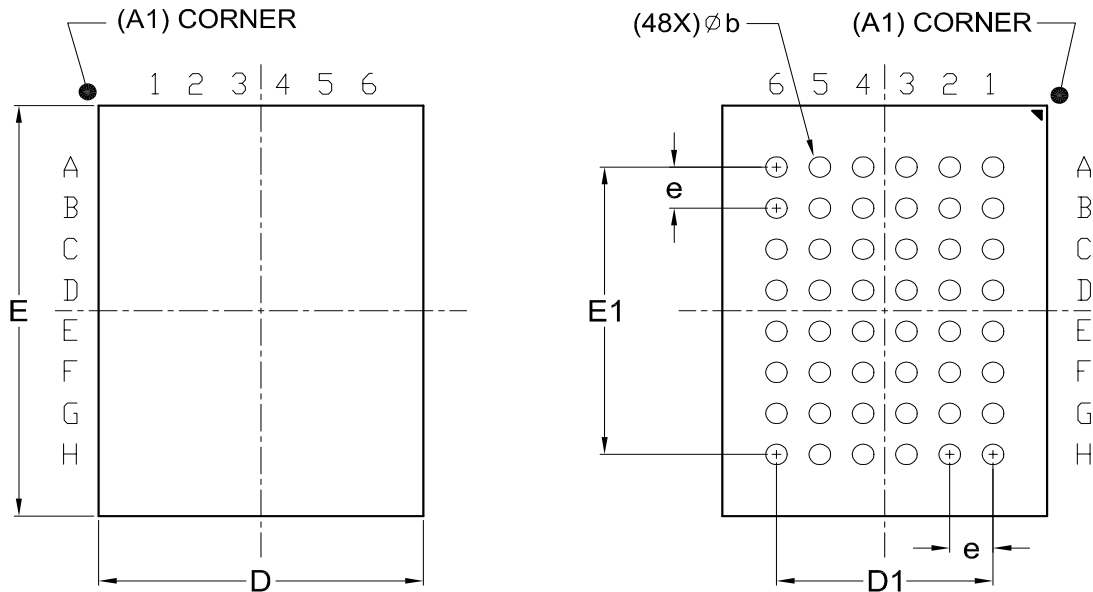
PART NO.	ACCESS TIME (ns)	OPERATING Current MAX. (mA)	STANDBY Current MAX. (uA)	PACKAGE	Remark
MX26LV800TTC-55	55	30	100	48 Pin TSOP (Normal Type)	
MX26LV800BTC-55	55	30	100	48 Pin TSOP (Normal Type)	
MX26LV800TTC-70	70	30	100	48 Pin TSOP (Normal Type)	
MX26LV800BTC-70	70	30	100	48 Pin TSOP (Normal Type)	
MX26LV800TXBC-55	55	30	100	48 Ball CSP (Ball size:0.3mm)	
MX26LV800BXBC-55	55	30	100	48 Ball CSP (Ball size:0.3mm)	
MX26LV800TXBC-70	70	30	100	48 Ball CSP (Ball size:0.3mm)	
MX26LV800BXBC-70	70	30	100	48 Ball CSP (Ball size:0.3mm)	
MX26LV800TXEC-55	55	30	100	48 Ball CSP (Ball size:0.4mm)	
MX26LV800BXEC-55	55	30	100	48 Ball CSP (Ball size:0.4mm)	
MX26LV800TXEC-70	70	30	100	48 Ball CSP (Ball size:0.4mm)	
MX26LV800BXEC-70	70	30	100	48 Ball CSP (Ball size:0.4mm)	

PACKAGE INFORMATION
Title: Package Outline for TSOP(I) 48L (12X20mm)NORMAL FORM


Dimensions (inch dimensions are derived from the original mm dimensions)

SYMBOL		A	A1	A2	b	C	D	D1	E	e	L	L1	θ
mm	Min.	---	0.05	0.95	0.17	0.10	19.80	18.30	11.90		0.50	0.70	0
	Nom.	---	0.10	1.00	0.20	0.13	20.00	18.40	12.00	0.50	0.60	0.80	5
	Max.	1.20	0.15	1.05	0.27	0.21	20.20	18.50	12.10		0.70	0.90	8
Inch	Min.	---	0.002	0.037	0.007	0.004	0.780	0.720	0.469		0.020	0.028	0
	Nom.	---	0.004	0.039	0.008	0.005	0.787	0.724	0.472	0.020	0.024	0.031	5
	Max.	0.047	0.006	0.041	0.011	0.008	0.795	0.728	0.476		0.028	0.035	8

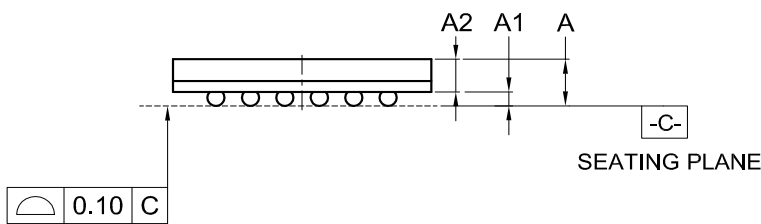
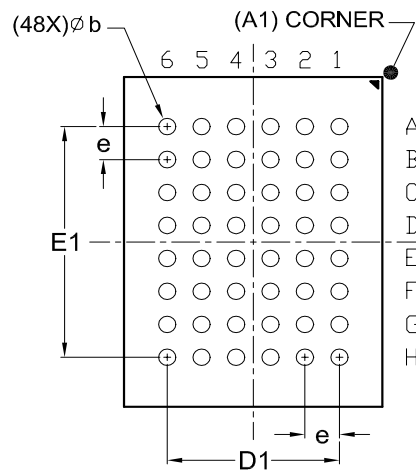
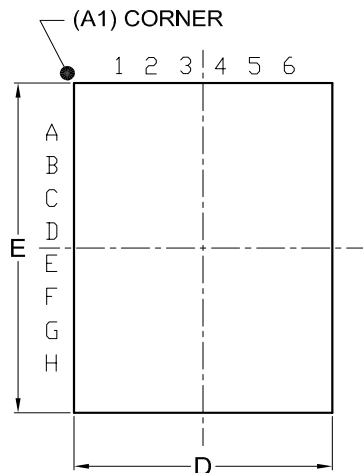
DWG.NO.	REVISION	REFERENCE			ISSUE DATE
		JEDEC	EIAJ		
6110-1607	7	MO-142			12-01-'03

48-Ball CSP (for MX26LV800ATXBC/ATXBI/ABXBC/ABXBI)
Title: Package Outline for CSP 48BALL(6X8X1.2MM,BALL PITCH 0.8MM,BALL DIAMETER 0.3MM)
TOP VIEW
BOTTOM VIEW


Dimensions (inch dimensions are derived from the original mm dimensions)

SYMBOL		A	A1	A2	b	D	D1	E	E1	e
mm	Min.	---	0.18	0.65	0.27	5.90		7.90		
	Nom.	---	0.23	---	0.30	6.00	4.00	8.00	5.60	0.80
	Max.	1.20	0.28	---	0.37	6.10		8.10		
Inch	Min.	---	0.007	0.026	0.011	0.232		0.311		
	Nom.	---	0.009	---	0.012	0.236	0.157	0.315	0.220	0.031
	Max.	0.047	0.011	---	0.015	0.240		0.319		

DWG.NO.	REVISION	REFERENCE			ISSUE DATE
		JEDEC	EIAJ		
6110-4201	4	MO-210			12-12-'03

48-Ball CSP (for MX26LV800ATXEC/ATXEI/ABXEC/ABXEI)
Title: Package Outline for CSP 48BALL(6X8X1.3MM,BALL PITCH 0.8MM,BALL DIAMETER 0.4MM)
TOP VIEW
BOTTOM VIEW


Dimensions (inch dimensions are derived from the original mm dimensions)

SYMBOL		A	A1	A2	b	D	D1	E	E1	e
mm	Min.	---	0.25	0.65	0.35	5.90		7.90		
	Nom.	---	0.30	---	0.40	6.00	4.00	8.00	5.60	0.80
	Max.	1.30	0.35	---	0.45	6.10		8.10		
Inch	Min.	---	0.010	0.026	0.014	0.232		0.311		
	Nom.	---	0.012	---	0.016	0.236	0.157	0.315	0.220	0.031
	Max.	0.051	0.014	---	0.018	0.240		0.319		

DWG.NO.	REVISION	REFERENCE			ISSUE DATE
		JEDEC	EIAJ		
6110-4202	4	MO-219			12-12-'03



REVISION HISTORY

Revision No.	Description	Page	Date
1.0	1. Modified ILI data from ± 1 (max.) to 1 (typ.)/3 (max.) 2. Removed "Advanced Information" title	P19 P1	MAR/10/2004
1.1	1. Modified the erase/program cycling to 2K cycles 2. Removed data retention table	P1,41 P41	JUN/24/2004
1.2	1. Modified the erase/program cycling to 2K cycles in General Description & Erase and Programming Performance notes	P1,41	JUL/08/2004



MX26LV800T/B

MACRONIX INTERNATIONAL Co., LTD.

HEADQUARTERS:

TEL:+886-3-578-6688

FAX:+886-3-563-2888

EUROPE OFFICE:

TEL:+32-2-456-8020

FAX:+32-2-456-8021

JAPAN OFFICE:

TEL:+81-44-246-9100

FAX:+81-44-246-9105

SINGAPORE OFFICE:

TEL:+65-348-8385

FAX:+65-348-8096

TAIPEI OFFICE:

TEL:+886-2-2509-3300

FAX:+886-2-2509-2200

MACRONIX AMERICA, INC.

TEL:+1-408-453-8088

FAX:+1-408-453-8488

CHICAGO OFFICE:

TEL:+1-847-963-1900

FAX:+1-847-963-1909

[http : //www.macronix.com](http://www.macronix.com)