



### Dual N-Channel Enhancement Mode Power MOSFET **MX8205**

#### **MX8205 DESCRIPTION**

The MX8205 uses advanced trench technology to provide excellent  $R_{DS(ON)}$  and low gate charge. It can be used in a wide variety of applications.

#### **MX8205 GENERAL FEATURES**

- $V_{DS}=20V$ ,  $I_D=6A$   
 $R_{DS(ON)}(Typ.)=20m\Omega$  @  $V_{GS}=4.5V$   
 $R_{DS(ON)}(Typ.)=21m\Omega$  @  $V_{GS}=3.8V$   
 $R_{DS(ON)}(Typ.)=26m\Omega$  @  $V_{GS}=2.5V$
- High Power and current handling capability
- Lead free product is acquired
- Surface Mount Package

#### **MX8205 APPLICATION**

- Battery protection
- Load switch

#### **MX8205 PINOUT**

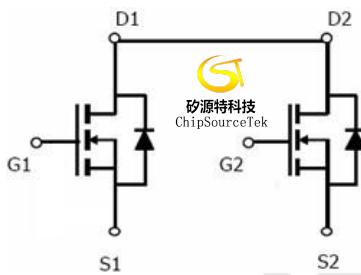

Schematic diagram

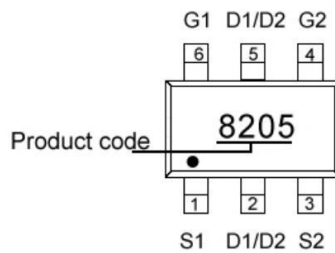

Marking and Pin Assignment

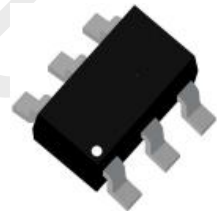

SOT23-6 top view

#### **MX8205 ORDERING INFORMATION**

Part Number	Storage Temperature	Package	Devices Per Reel
MX8205	-55°C to 150°C	SOT23-6	3000

#### **MX8205 ABSOLUTE MAXIMUM RATINGS** ( $T_A=25^\circ C$ unless otherwise noted)

Parameter	Symbol	Limit	Unit
Drain-Source Voltage	$V_{DS}$	20	V
Gate-Source Voltage	$V_{GS}$	$\pm 12$	V
Drain Current-Continuous	$I_D$	6	A
Drain Current-Pulsed <sup>(Note1)</sup>	$I_{DM}$	24	A
Maximum Power Dissipation	$P_D$	1.5	W
Operating Junction and Storage Temperature Range	$T_J, T_{STG}$	-55 to 150	$^\circ C$

#### **MX8205 ERMAL RESISTANCE**

Thermal Resistance, Junction-to-Ambient <sup>(Note2)</sup>	$R_{\theta JA}$	83	$^\circ C/W$
--	-----------------	----	--------------

Note 1. Repetitive Rating: Pulse width limited by maximum junction temperature.

Note 2. Surface Mounted on FR4 Board,  $t \leq 10$  sec.



#### MX8205 ELECTRICAL CHARACTERISTICS (T<sub>A</sub>=25°C unless otherwise noted)

Parameter	Symbol	Conditions	Min	Typ	Max	Unit
-----------	--------	------------	-----	-----	-----	------

#### Off Characteristics

Drain-Source Breakdown Voltage	BV <sub>DSS</sub>	V <sub>GS</sub> =0V, I <sub>D</sub> =250μA	20	-	-	V
Zero Gate Voltage Drain Current	I <sub>DSS</sub>	V <sub>DS</sub> =20V, V <sub>GS</sub> =0V	-	-	1	μA
Gate-Body Leakage Current	I <sub>GSS</sub>	V <sub>GS</sub> =±12V, V <sub>DS</sub> =0V	-	-	±100	nA

#### On Characteristics<sup>(Note 3)</sup>

Gate Threshold Voltage	V <sub>GS(th)</sub>	V <sub>DS</sub> =V <sub>GS</sub> , I <sub>D</sub> =250μA	0.45	0.7	1.2	V
Drain-Source On-State Resistance	R <sub>DS(ON)</sub>	V <sub>GS</sub> =4.5V, I <sub>D</sub> =4.5A	18	20	24	mΩ
		V <sub>GS</sub> =3.8V, I <sub>D</sub> =4A	19	21	26	mΩ
		V <sub>GS</sub> =2.5V, I <sub>D</sub> =3.5A	24	26	32	mΩ
Forward Transconductance	g <sub>FS</sub>	V <sub>DS</sub> =5V, I <sub>D</sub> =4.5A	-	10	-	S

#### Dynamic Characteristics<sup>(Note4)</sup>

Input Capacitance	C <sub>iss</sub>	V <sub>DS</sub> =10V, V <sub>GS</sub> =0V, F=1.0MHz	-	600	-	pF
Output Capacitance	C <sub>oss</sub>		-	330	-	pF
Reverse Transfer Capacitance <sup>(Note4)</sup>	C <sub>rss</sub>		-	140	-	pF

#### Switching Characteristics<sup>(Note4)</sup>

Turn-on Delay Time	t <sub>d(on)</sub>	V <sub>DD</sub> =10V, I <sub>D</sub> =1A V <sub>GS</sub> =4.5V, R <sub>G</sub> =6Ω	-	10	-	nS
Turn-on Rise Time	t <sub>r</sub>		-	11	-	nS
Turn-Off Delay Time	t <sub>d(off)</sub>		-	35	-	nS
Turn-Off Fall Time	t <sub>f</sub>		-	30	-	nS
Total Gate Charge	Q <sub>g</sub>	V <sub>DS</sub> =10V, I <sub>D</sub> =6A, V <sub>GS</sub> =4.5V	-	10	-	nC
Gate-Source Charge	Q <sub>gs</sub>		-	1.5	-	nC
Gate-Drain Charge	Q <sub>gd</sub>		-	2.3	-	nC

#### Drain-Source Diode Characteristics

Diode Forward Voltage <sup>(Note 3)</sup>	V <sub>SD</sub>	V <sub>GS</sub> =0V, I <sub>S</sub> =1A	-	-	1.2	V
Diode Forward Current <sup>(Note 2)</sup>	I <sub>S</sub>		-	-	6	A

Note 2. Surface Mounted on FR4 Board, t ≤ 10 sec.

Note 3. Pulse Test: Pulse Width ≤ 300μs, Duty Cycle ≤ 2%.

Note 4. Guaranteed by design, not subject to product.



#### MX8205 TYPICAL ELECTRICAL AND THERMAL CHARACTERISTICS

**Figure 1. Switching Test Circuit**

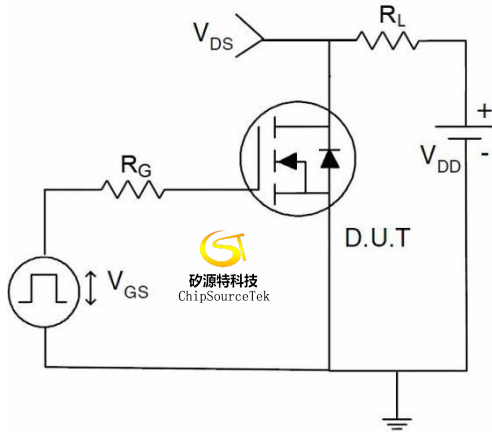

**Figure 2. Switching Waveform**

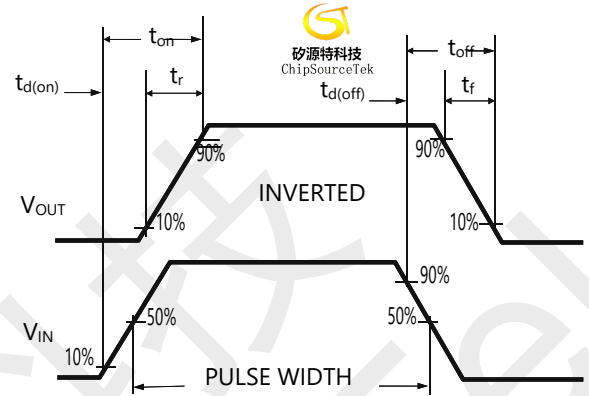

**Figure 3. Power Dissipation**

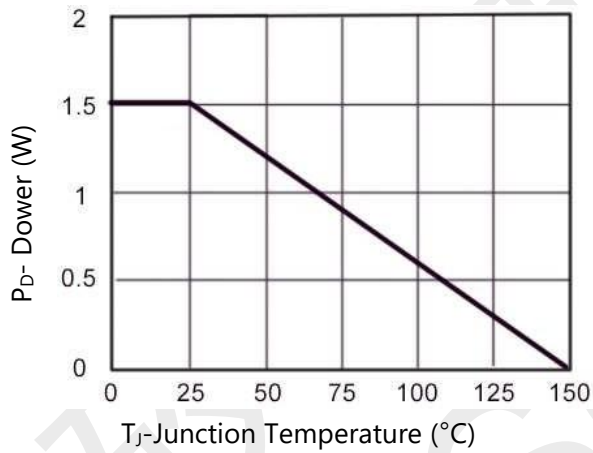

**Figure 4. Drain Current**

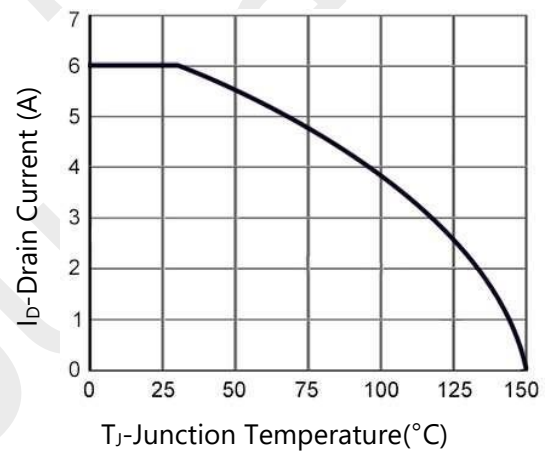

**Figure 5. Output Characteristics**

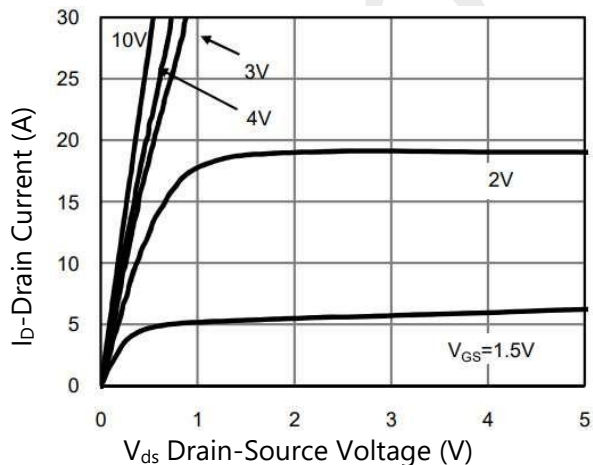

**Figure 6. R<sub>ds(on)</sub> vs Drain Current**

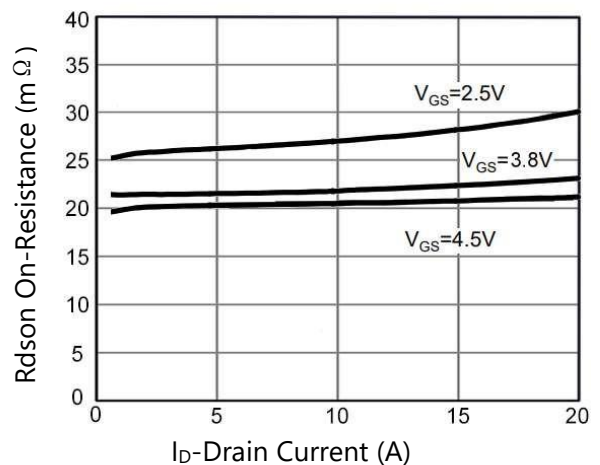



#### MX8205 TYPICAL ELECTRICAL AND THERMAL CHARACTERISTICS

**Figure 7. Transfer Characteristics**

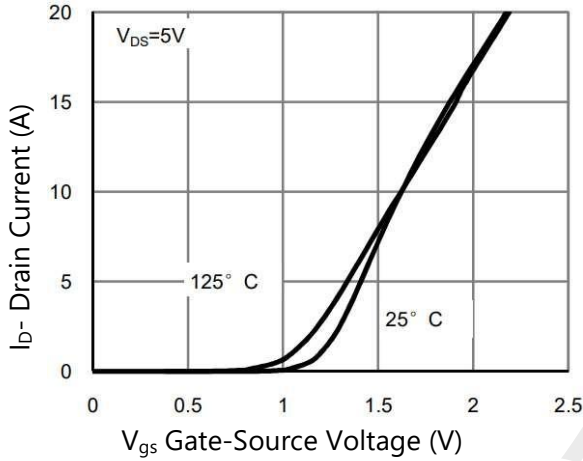

**Figure 8.  $R_{dson}$  vs Junction Temperature**

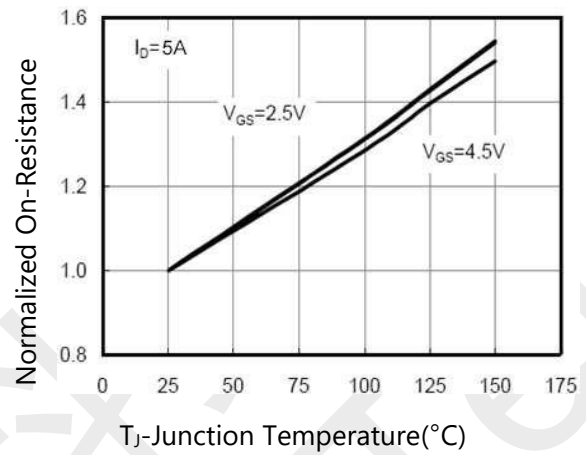

**Figure 9.  $R_{dson}$  vs  $V_{gs}$**

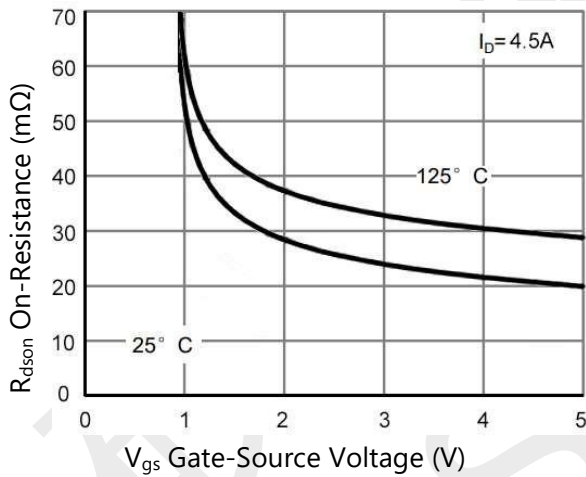

**Figure 10. Capacitance vs  $V_{ds}$**

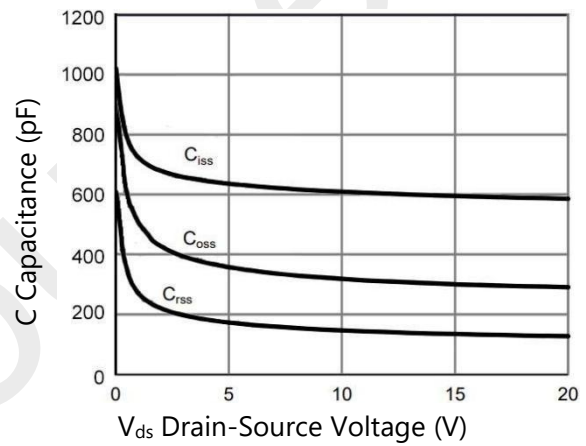

**Figure 11. Gate Charge**

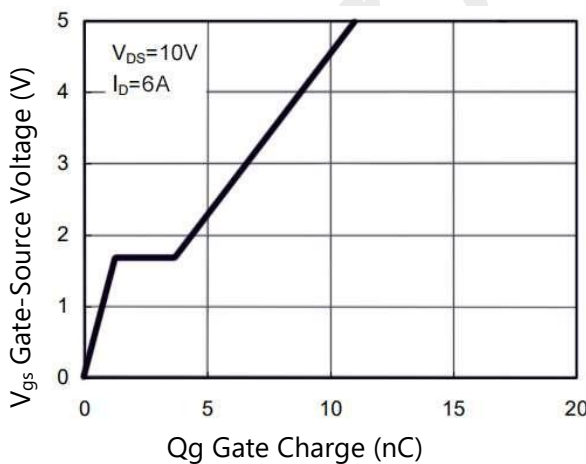

**Figure 12. Source-Drain Diode Forward**

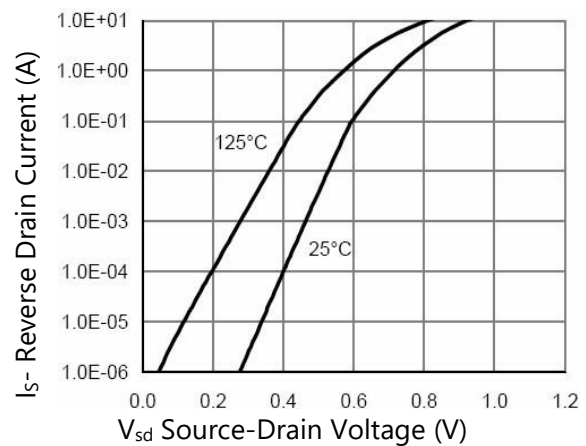



#### MX8205 TYPICAL ELECTRICAL AND THERMAL CHARACTERISTICS

Figure 13. Safe Operation Area

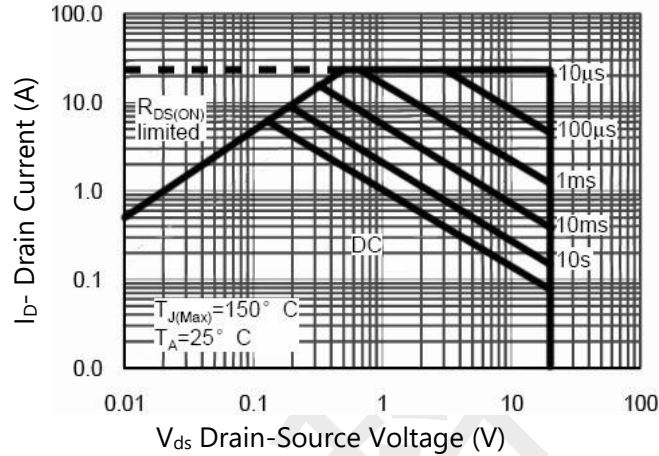
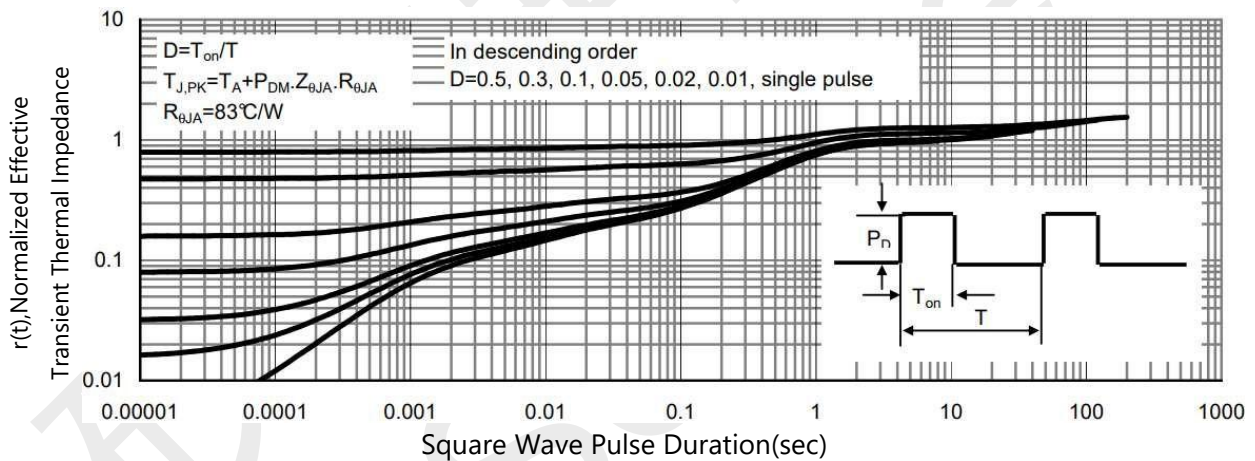

Figure 14. Normalized Maximum Transient Thermal Impedance







#### MX8205 PACKAGE INFORMATION

#### SOT23-6

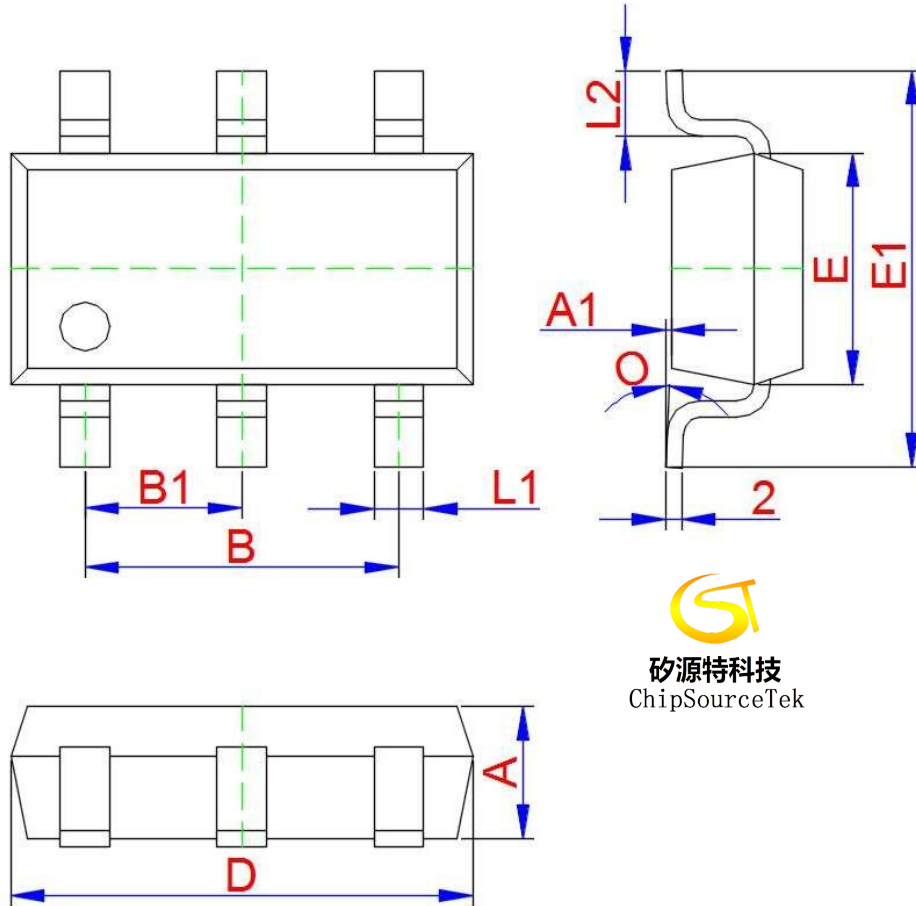

Symbol	Dimensions In Millimeters		
	Min.	Typ.	Max.
A	1.050	1.100	1.150
A1	0.000	0.050	0.100
L1	0.300	0.400	0.500
C	0.100	0.150	0.200
D	2.820	2.920	3.020
E	1.500	1.600	1.700
E1	2.650	2.800	2.950
B	1.800	1.900	2.000
B1	0.950 TYP.		
L2	0.300	0.450	0.600
O	0°	4°	8°