

SPECIFICATION

MX8735

USB/PS2 Single Chip Optical Mouse Sensor

VERSION 1.1

TABLE OF CONTENTS

1. General Description	3
2. Features.....	3
3. Pin Assignment	4
4. Absolute Maximum Rating.....	4
5. Electrical Characteristic.....	5
6. DC Electrical Characteristic.....	5
7. Application Circuit.....	6
7.1 3D3K Application Circuit	6
7.2 3D4K Application Circuit	6
8. Package (Dimension In mm).....	7
9. Revision History	7

1. General Description

The MX8735 chip is a low cost single chip optical mouse solution used to implement a non-mechanical tracking engine for computer mice. It is based on optical navigation technology with USB/PS2 combo MCU bundled. Which measures changes in position by optically acquiring sequential surface images(frames) and mathematically determining the direction and magnitude of movement. The single chip optical mouse sensor provides a complete and compact mouse solution, There are no moving parts, and precision optical alignment is not required, few outside components use and facilitate high volume assembly. It is a true crystal-less and ultra low cost solution.

2. Features

- Optical Navigation Technology
- Low-cost and powerful solution for PS/2 and low-speed USB combo mouse
- Microsoft 3D Intellimouse and IBM PS/2 mouse compatible
- Internal switch for USB DP/DM and PS2 CLK/Data I/O
- Universal Serial Bus Specification, version 2.0
- USB HID Specification, version 1.1
- USB-IF and WHQL compliable
- 5V Power Supply
- Power Saving During No Motion
- On Chip LED Drive with Regulated Current
- Crystal-less
- Resolution 1000(Default) /1600/2000 CPI
- Low EMI radiation
- Supports 3D (X, Y, Z) input
- Supports 3 buttons and mechanical wheel encoding

3. Pin Assignment

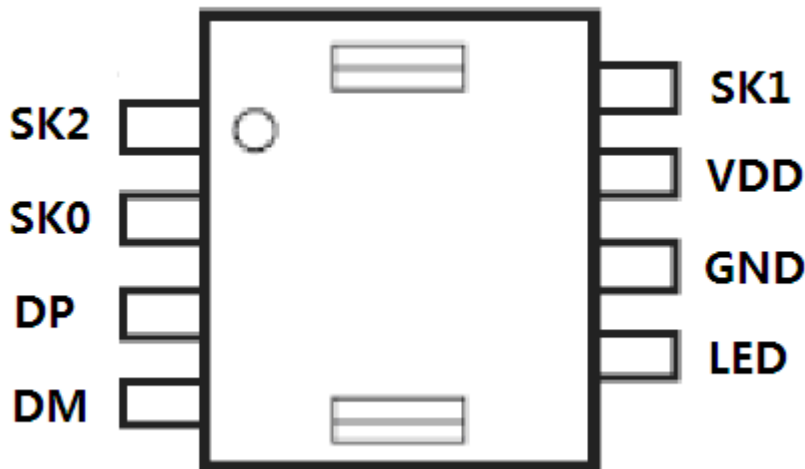

Chart 1 Pin Assignment

Pin No.	Symbol	I/O	Function
1	SK2	I/O	Z axis Input 2 and DPI button input
2	SK0	I/O	Z axis Input 1 and Left button input
3	DP/CLK	I/O	USB D+ / PS2 CLK
4	DM/DATA	I/O	USB D- / PS2 DATA
5	LED	O	LED control (sink current) and key scan
6	GND	P	GND
7	VDD	P	5V Power Input
8	SK1	I/O	Right button input and Middle button input

4. Absolute Maximum Rating

Symbol	Min.	Max.	Unit
Operating Temperature	0	70	°C
Storage Temperature	-65	150	°C
Input voltage	-0.5	6.0	V
Output voltage	-0.5	6.0	V

5. Electrical Characteristic

Test Condition: T = 25°C, VDD=5.0V, VSS=0V

Parameters	Sym.	Min.	Typ.	Max.	Unit
Operating voltage	VDD	4.5	5.0	5.5	V
Operating Current (normal operation)	IOP	-	-	15	mA
Operating Current (Sleep mode)	Isleep	-	7.0	-	mA
USB suspend current	Isuspend	-	-	500	uA
L, M, R, debounce time	Tb	17	-	-	ms
Z-axis debounce time	Tz	700	-	-	μs
Acceleration	A	-	-	8	g
Frame Rate	FR	-	2800	-	Frames/sec
Speed	S	-	-	30	Inches/sec

6. DC Electrical Characteristic

(T=25°C, Vdd=5V, Vss=0V)

Symbol	Parameter	Condition	Min	Type	Max	Unit
MCU operation						
Iil	Input Leakage Current for input pins	VIN=VDD, VSS	-	-	±1	uA
Icc	VDD operating supply current Normal frequency operation mode	Output pins floating	-	-	10	mA
USB Interface						
Voh	Static Output High	USB operation Mode	2.8	-	3.6	V
Vol	Static Output Low		-	-	0.3	V
Vdi	Differential Input Sensitivity		0.2	-	-	V
Vcm	Differential Input Command Mode Range		0.8	-	2.5	V
Vse	Single Ended Receiver Threshold		0.8	-	2.0	V
Cin	Transceiver Capacitance		-	-	20	PF
Vrg	Output Voltage of internal Regulator		3.0	-	3.6	V

7. Application Circuit

7.1 3D3K Application Circuit

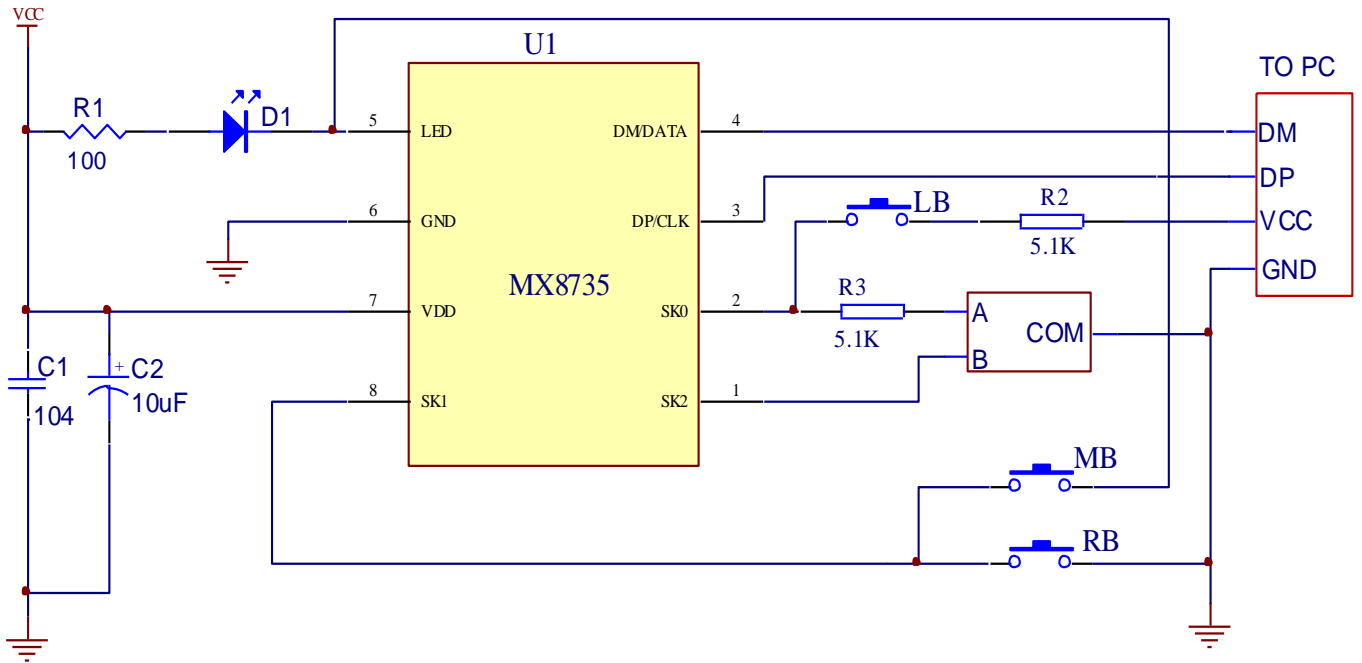

7.2 3D4K Application Circuit

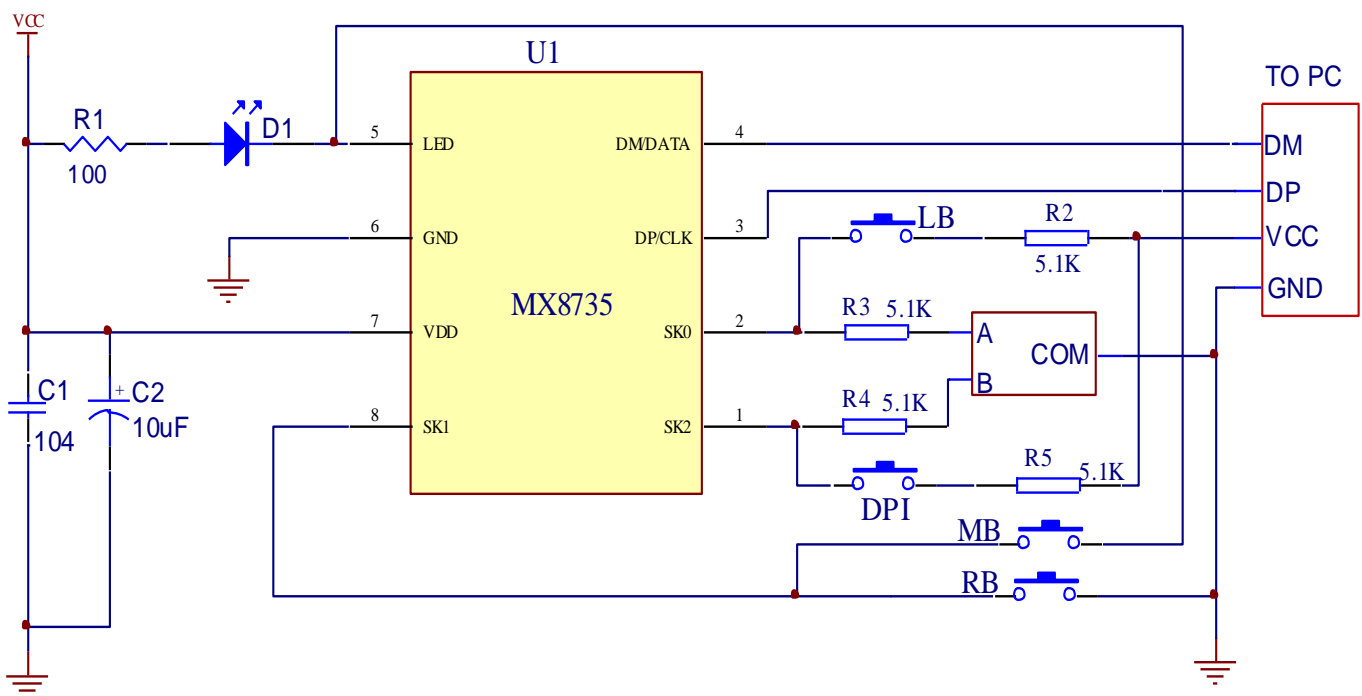

Note:

1. The capacitance C1 & C2 have to close to IC (Pin6 & Pin7).
2. D+/CLK and D-/DATA signal line have the short trace to IC.
3. Recommend to have ground grid on the PCB periphery.

8. Package (Dimension In mm)

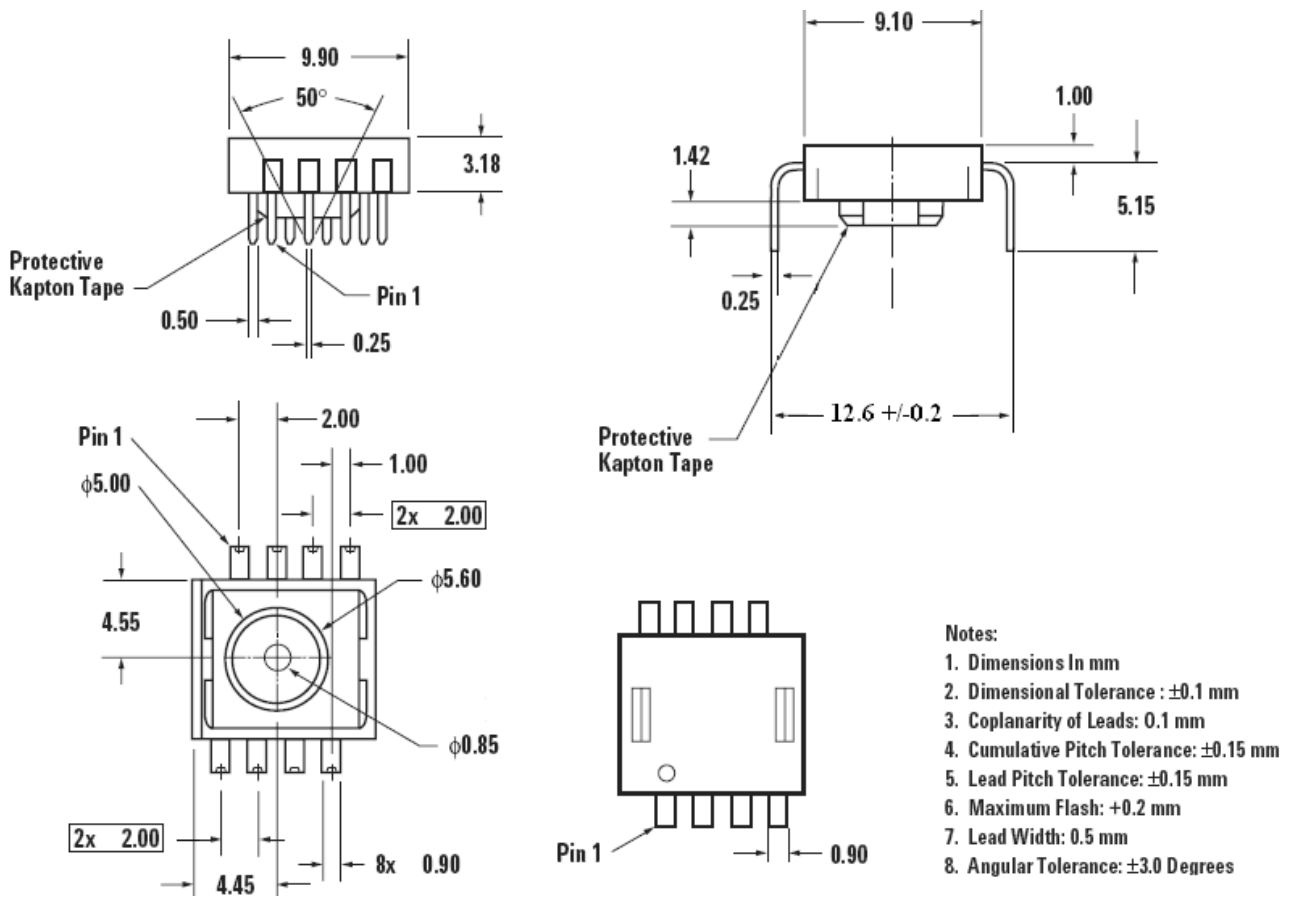

9. Revision History

Version	Update date	Revised Content	Revised by	Confirmed by
V1.0	2014-5-22	Original	LiuXing	
V1.1	2016-7-1	Update some parameters	LiuXing	