



N-Channel Enhancement Mode Power MOSFET **MXB6888**

DESCRIPTION

The MXB6888 is N-channel MOS Field Effect Transistor designed for high current switching applications. Rugged E_{AS} capability and ultra low $R_{DS(ON)}$ is suitable for PWM, load switching especially for E-Bike controller applications.

GENERAL FEATURES

- $V_{DS}=68V$, $I_D=80A$ @ $V_{GS}=10V$
 $R_{DS(ON)}(Typ.)=6.8m\Omega$ @ $V_{GS}=10V$
- Special Designed for E-Bike Controller Application
- Ultra Low On-Resistance
- High UIS and UIS 100% Test

APPLICATION

- 48V E-Bike Controller Applications
- Hard Switched and High Frequency Circuits
- Uninterruptible Power Supply

PINOUT

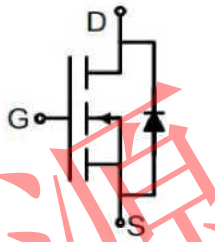

Schematic diagram

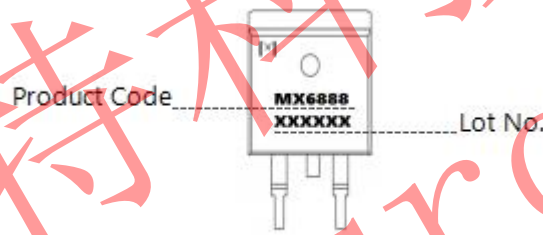

Marking and pin Assignment



TO-263 top view

KEY PERFORMANCE PARAMETERS ($T_A=25^\circ C$ unless otherwise noted)

Parameter	Value	Unit
V_{DS} @ $T_C=25^\circ C$	68	V
$R_{DS(ON)}(Typ.)$ @ $V_{GS}=10V$	6.8	$m\Omega$
$Q_g(Typ.)$	56	nC
I_D @ $T_C=25^\circ C$	80	A
P_D @ $T_C=25^\circ C$	75	W
T_J TSTG	-55 to 175	$^\circ C$

PACKAGE INFORMATION

Package	TO-263
---------	--------



N-Channel Enhancement Mode Power MOSFET **MXB6888**

ABSOLUTE MAXIMUM RATINGS ($T_A=25^\circ\text{C}$ unless otherwise noted)

Parameter	Symbol	Limit	Unit
Drain-Source Voltage ($V_{GS}=0\text{V}$)	V_{DS}	68	V
Gate-Source Voltage ($V_{DS}=0\text{V}$)	V_{GS}	± 20	V
Drain Current (DC) at $T_C=25^\circ\text{C}$	$I_{D(DC)}$	80	A
Drain Current (DC) at $T_C=100^\circ\text{C}$	$I_{D(DC)}$	45	A
Drain Current-Continuous@ Current-Pulsed (Note1)	$I_{DM(pluse)}$	260	A
Peak Diode Recovery Voltage	dv/dt	8	V/ns
Maximum Power Dissipation($T_C=25^\circ\text{C}$)	P_D	75	W
Derating Factor		0.5	W/ $^\circ\text{C}$
Single Pulse Avalanche Energy (Note 2)	E_{AS}	300	mJ
Operating Junction and Storage Temperature Range	T_J, T_{STG}	-55 to 175	$^\circ\text{C}$

Notes 1 . Repetitive Rating: Pulse width limited by maximum junction temperature
2. E_{AS} condition: $T_J=25^\circ\text{C}$, $V_{DD}=33\text{V}$, $V_G=10\text{V}$

THERMAL RESISTANCE

Parameter	Symbol	Max.	Unit
Thermal Resistance, Junction-to-Case	$R_{\theta JC}$	2.34	$^\circ\text{C}/\text{W}$



N-Channel Enhancement Mode Power MOSFET **MXB6888**



ELECTRICAL CHARACTERISTICS ($T_A=25^\circ\text{C}$ unless otherwise noted)

Parameter	Symbol	Condition	Min	Typ	Max	Unit
On/Off Characteristics						
Drain-Source Breakdown Voltage	BV_{DSS}	$V_{GS}=0V, I_D=250\mu A$	68	-	-	V
Zero Gate Voltage Drain Current	I_{DSS}	$V_{DS}=64V, V_{GS}=0V$	-	-	1	μA
Gate-Body Leakage Current	I_{GSS}	$V_{GS}=\pm 20V, V_{DS}=0V$	-	-	± 100	nA
Gate Threshold Voltage	$V_{GS(th)}$	$V_{DS}=V_{GS}, I_D=250\mu A$	2	-	4	V
Drain-Source On-State Resistance	$R_{DS(ON)}$	$V_{GS}=10V, I_D=40A$	-	6.8	8.2	m Ω

Dynamic Characteristics

Forward Transconductance	g_{FS}	$V_{DS}=10V, I_D=15A$	15	-	-	S
Input Capacitance	C_{iss}	$V_{DS}=25V, V_{GS}=0V,$ $F=1.0MHz$	-	2873	-	pF
Output Capacitance	C_{oss}		-	252	-	pF
Reverse Transfer Capacitance	C_{rss}		-	205	-	pF
Total Gate Charge	Q_g	$V_{DS}=50V, I_D=40A,$ $V_{GS}=10V$	-	56	-	nC
Gate-Source Charge	Q_{gs}		-	10	-	nC
Gate-Drain Charge	Q_{gd}		-	16	-	nC

Switching Characteristics

Turn-on Delay Time	$t_{d(on)}$	$V_{DD}=30V, I_D=2A,$ $R_L=15\Omega$ $V_{GS}=10V, R_{GEN}=2.5\Omega$	-	14.5	-	nS
Turn-on Rise Time	t_r		-	24	-	nS
Turn-Off Delay Time	$t_{d(off)}$		-	45	-	nS
Turn-Off Fall Time	t_f		-	22	-	nS

Source-Drain Diode Characteristics

Forward On Voltage ^(Note1)	V_{SD}	$T_J=25^\circ\text{C}, V_{GS}=0V,$ $I_S=40A$	-	0.89	0.99	V
Source-Drain Current(Body Diode)	I_{SD}		-	65	-	A
Pulsed Source-Drain Current(Body Diode)			-	260	-	A
Reverse Recovery Time ^(Note1)	t_{rr}	$T_J=25^\circ\text{C}, I_F=75A,$ $di/dt=100A/\mu s$	-	22	-	nS
Reverse Recovery Charge ^(Note1)	Q_{rr}		-	27	-	nC
Forward Turn-On Time	t_{on}	Intrinsic turn-on time is negligible (turn-on is dominated by L_S+L_D)				

Notes 1. Pulse Test: Pulse Width $\leq 300\mu s$, Duty Cycle $\leq 1.5\%$, $R_G = 25\Omega$, Starting $T_J = 25^\circ\text{C}$



N-Channel Enhancement Mode Power MOSFET **MXB6888**

TYPICAL PERFORMANCE CHARACTERISTICS

1) E_{AS} Test Circuits

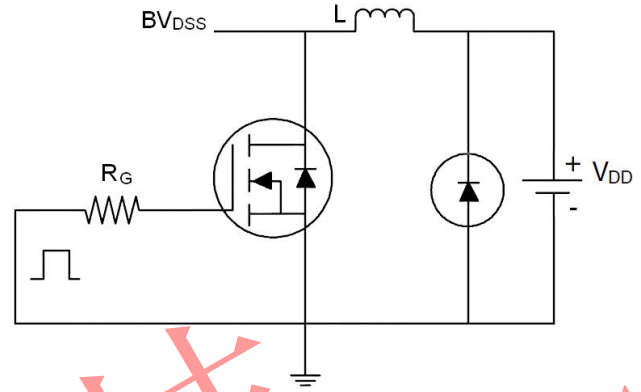
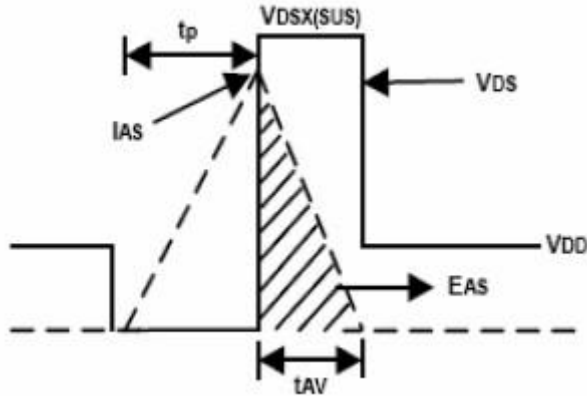

2) Gate Charge Test Circuit:

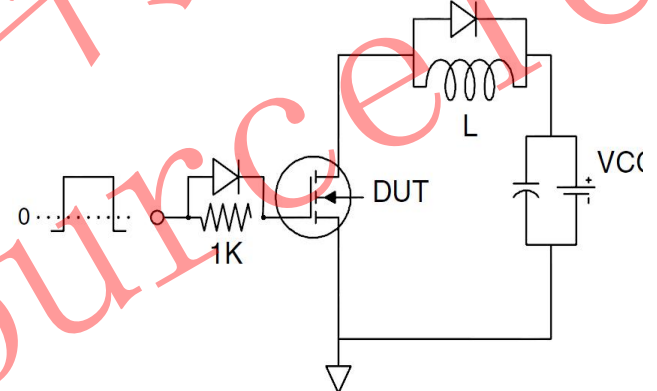
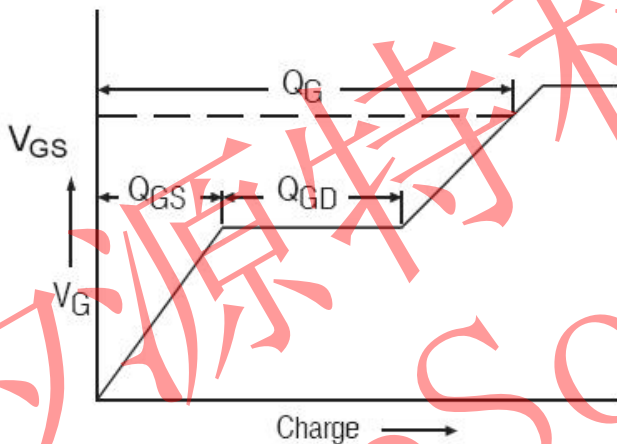

3) Switch Time Test Circuit:

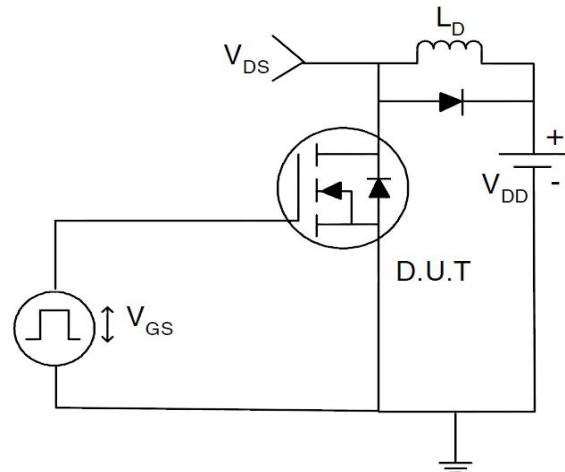
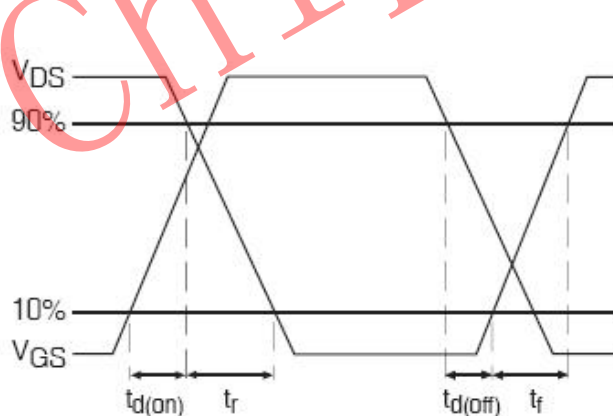



N-Channel Enhancement Mode Power MOSFET **MXB6888**

TYPICAL PERFORMANCE CHARACTERISTICS

Figure1. Output Characteristics

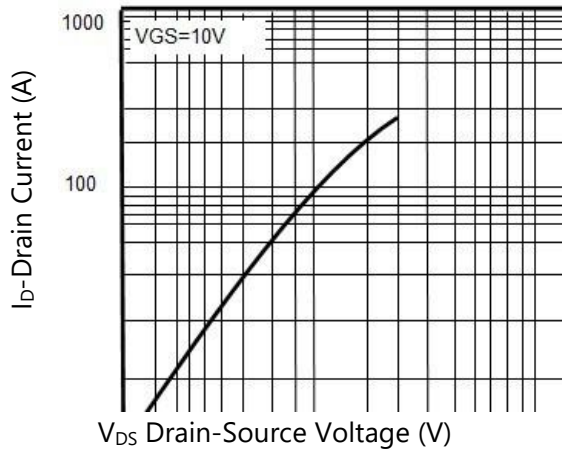

Figure2. Transfer Characteristics

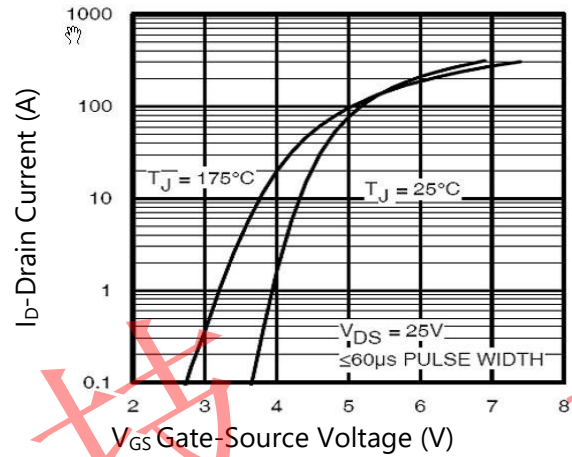

Figure3. BV_{DSS} vs Junction Temperature

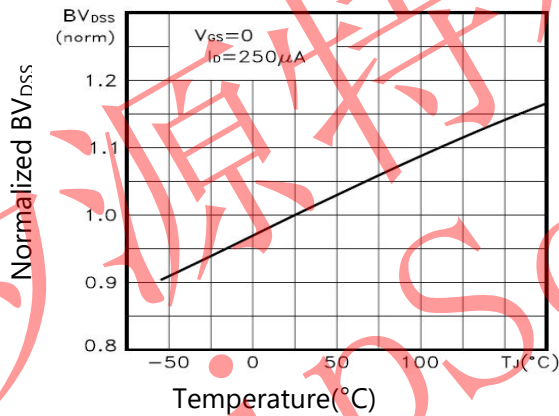

Figure4. I_D vs Junction Temperature

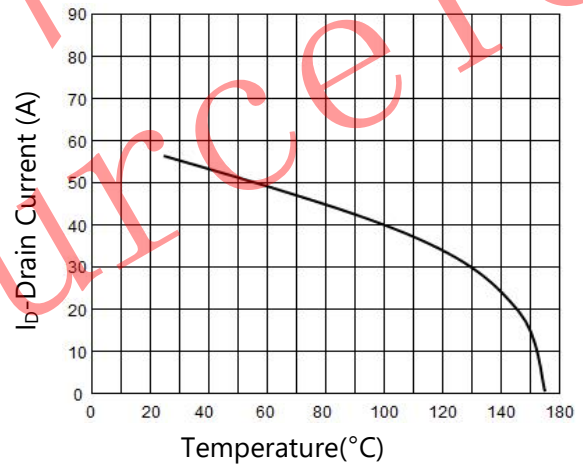

Figure5. $V_{GS(th)}$ vs Junction Temperature

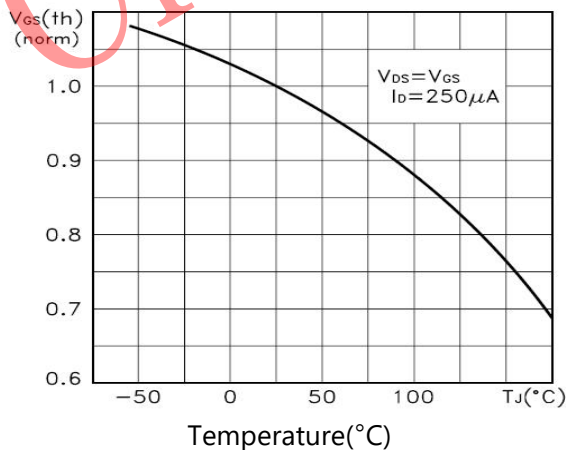
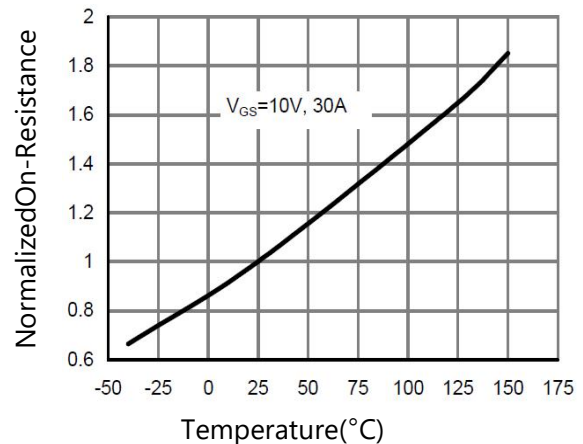

Figure6. R_{dson} Vs Junction Temperature





N-Channel Enhancement Mode Power MOSFET **MXB6888**

TYPICAL PERFORMANCE CHARACTERISTICS

Figure7. Gate Charge

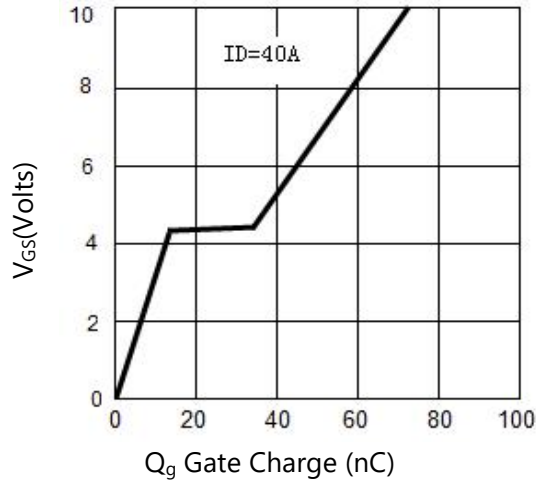

Figure8. Capacitance vs V_{DS}

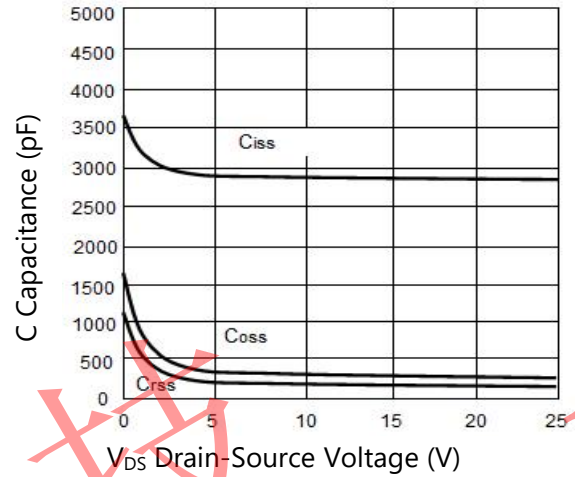

Figure9. Source- Drain Diode Forward

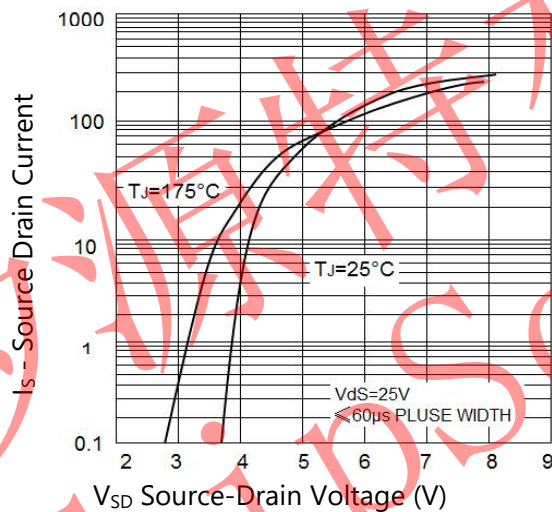

Figure10. Safe Operation Area

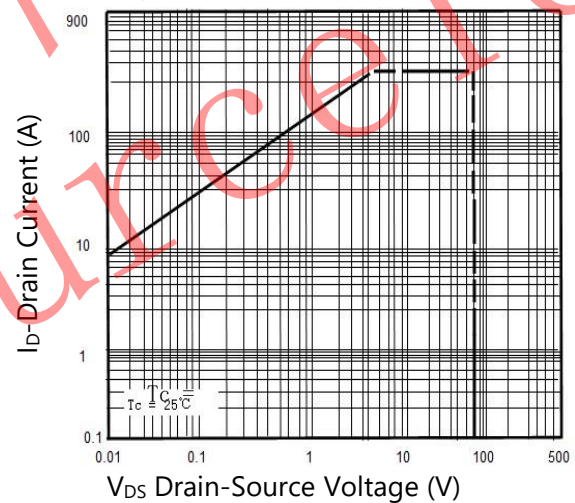
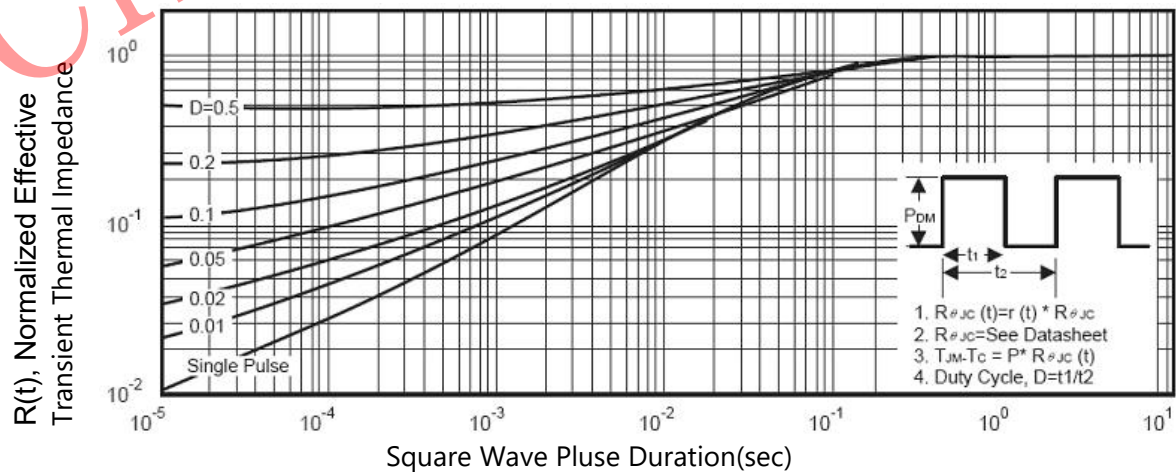

Figure11. Normalized Maximum Transient Thermal Impedance





N-Channel Enhancement Mode Power MOSFET **MXB6888**

PACKAGE INFORMATION

TO-263

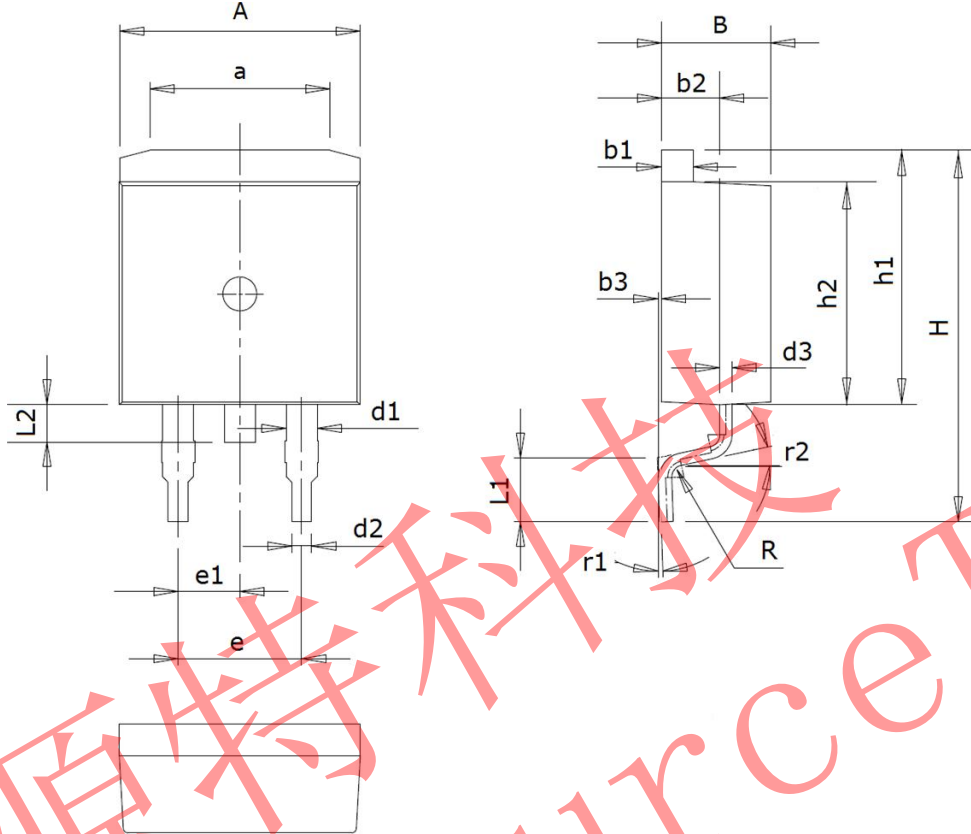

Symbol	Dimensions In Millimeters		Dimensions In Inches	
	Min.	Max.	Min.	Max.
A	9.60	10.0	0.378	0.394
a	7.00	7.80	0.276	0.307
B	4.30	4.70	0.169	0.185
b1	1.25	1.35	0.049	0.053
b2	2.20	2.60	0.087	0.102
b3	0.00	0.20	0.000	0.008
d1	1.20	1.40	0.047	0.055
d2	0.70	0.90	0.028	0.035
d3	0.40	0.60	0.016	0.024
e	5.08(typ.)		0.200(typ.)	
e1	2.54(typ.)		0.100(typ.)	
H	15.20	15.80	0.598	0.622
h1	10.30	10.70	0.406	0.421
h2	9.10	9.40	0.358	0.370
L1	2.40	2.90	0.094	0.114
L2	1.30	1.80	0.051	0.071
R	0.5(typ.)		0.020(typ.)	
r1	0°	8°	0°	8°
r2	12°(typ.)		12°(typ.)	