



MXD8668

SP6T Switch with MIPI for LTE Diversity



This document contains information that is confidential and proprietary to Maxscend Microelectronics Company Limited (Maxscend) and may not be reproduced in any form without express written consent of Maxscend. No transfer or licensing of technology is implied by this document.

General Description

The MXD8668 is a low loss, high isolation SP6T switch for antenna diversity receiving.

The MXD8668 is compatible with MIPI control, which is a key requirement for many cellular transceivers. This part is packaged in a compact 2mm x 2mm, 14-pin, QFN package which allows for a small solution size with no need for external DC blocking capacitors (when no external DC is applied to the device ports).

Features

- Excellent insertion loss
 - 0.50 dB Insertion Loss at 2.7GHz
- P0.1dB @ 27dBm
- Multi-Band operation 700MHz to 3000MHz
- RFFE serial control interface
- Compact 2mm x 2mm in QFN-14 package
- No DC blocking capacitors required (unless external DC is applied to the RF ports)

Applications

- 2G/3G/4G antenna diversity
- Cellular modems and USB Devices

Functional Block Diagram and Pin Function

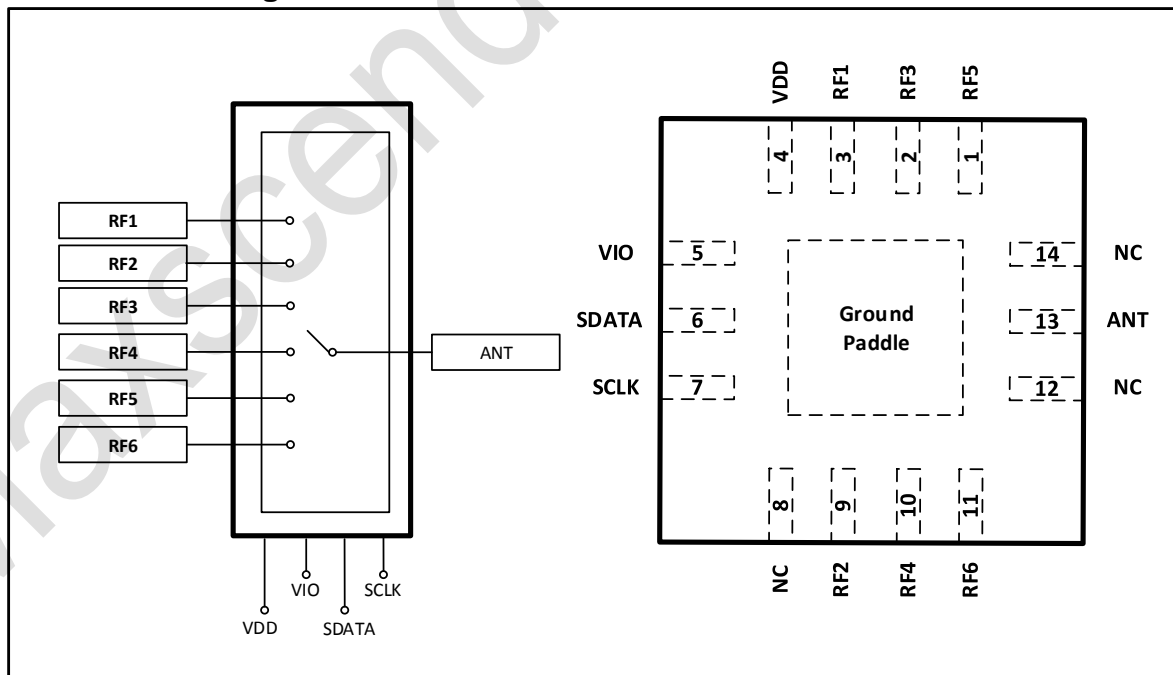

Figure 1. Functional Block Diagram and Pinout (Top View)

Application Circuit

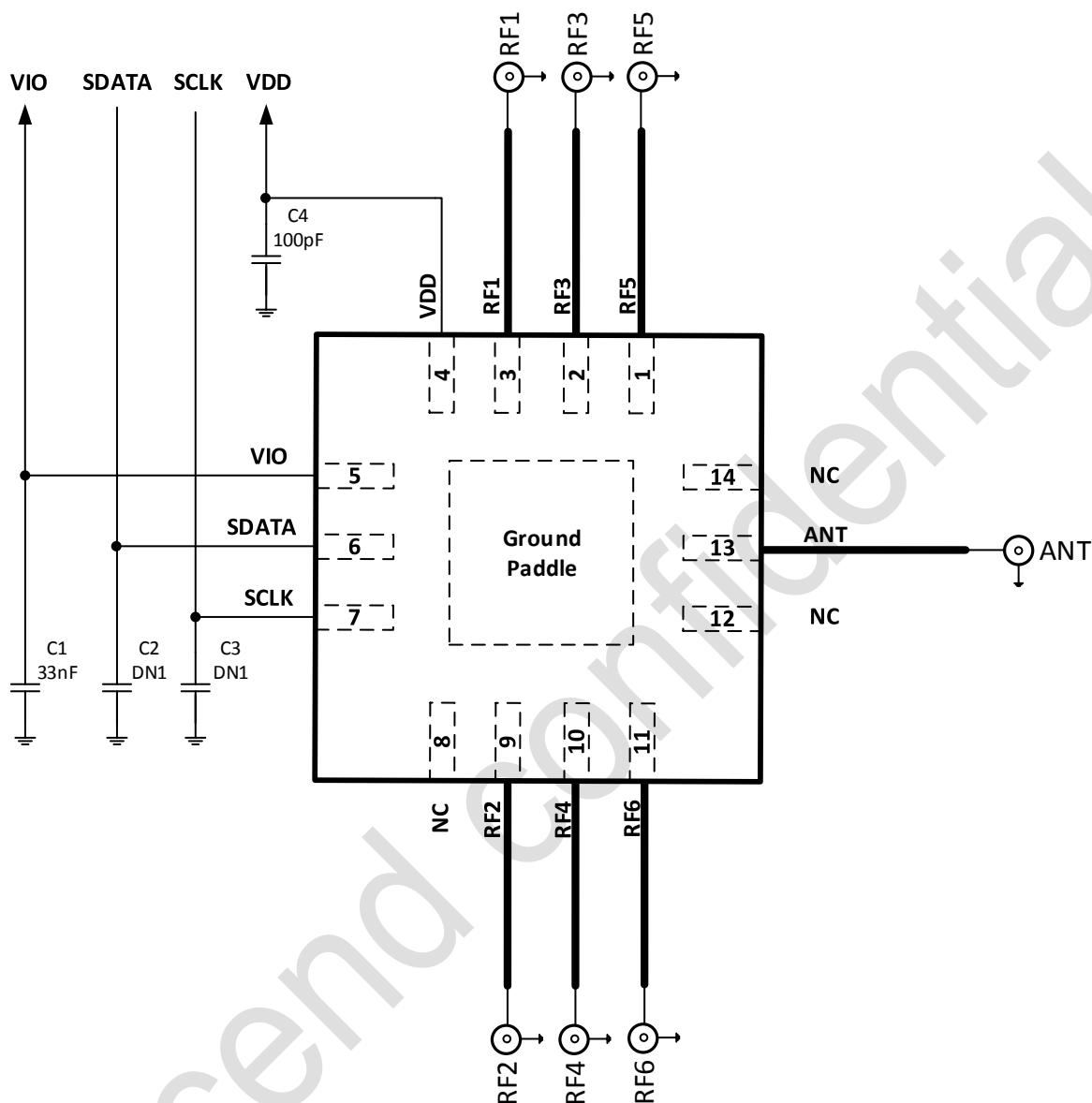

Figure 2. Evaluation Board Schematic

Table 1. Pin Description

Pin No.	Name	Description	Pin No.	Name	Description
1	RF5	RF port5	8	NC	-
2	RF3	RF port3	9	RF2	RF port2
3	RF1	RF port1	10	RF4	RF port4
4	VDD	Power supply	11	RF6	RF port6
5	VIO	Supply voltage for MIPI	12	NC	-
6	SDATA	MIPI data input/output	13	ANT	Antenna port
7	SCLK	MIPI clock	14	NC	-
Ground Paddle	GND	Ground			

Note: Bottom ground paddles must be connected to ground.

Truth Table
Table 2.

Control Register_0	Switched RF Outputs					
	RF1	RF2	RF3	RF4	RF5	RF6
0x00	Insertion Loss	Isolation	Isolation	Isolation	Isolation	Isolation
0x01	Isolation	Insertion Loss	Isolation	Isolation	Isolation	Isolation
0x02	Isolation	Isolation	Insertion Loss	Isolation	Isolation	Isolation
0x03	Isolation	Isolation	Isolation	Insertion Loss	Isolation	Isolation
0x04	Isolation	Isolation	Isolation	Isolation	Insertion Loss	Isolation
0x05	Isolation	Isolation	Isolation	Isolation	Isolation	Insertion Loss
0x06	Isolation	Isolation	Isolation	Isolation	Isolation	Isolation
0x07	Isolation	Isolation	Isolation	Isolation	Isolation	Isolation

Recommended Operation Range
Table 3. Recommended Operation Condition

Parameters	Symbol	Min	Typ	Max	Units
Operation Frequency	f1	0.7	-	3.0	GHz
Power supply	V _{DD}	2.5	2.8	3.0	V
Power supply for MIPI	V _{IO}	1.65	1.8	1.95	V
MIPI Control Voltage High	V _H	0.8*V _{IO}	1.8	1.95	V
MIPI Control Voltage Low	V _L	0	0	0.3	V

Specifications
Table 4. Electrical Specifications

Parameter	Symbol	Test Condition	Min	Typical	Max	Units
DC Specifications						
Supply voltage	V _{DD}		2.5	2.8	3.0	V
Supply current	I _{DD}			30	50	uA
V _{IO} supply voltage	V _{IO}		1.65	1.8	1.95	V
V _{IO} Supply current	I _{IO}			4	10	uA
SDATA, SCLK control voltage: High	V _{CTL_H}		0.8* V _{IO}	V _{IO}	1.95	V
Low	V _{CTL_L}		0	0	0.3	V
Switching Speed, one RF to another		10% to 90% RF		1	2	uS
RF Specifications						
Insertion loss (ANT pin to RF1/2/3/4/5/6 pins)	IL	0.1 to 1.0 GHz 1.0 to 2.0 GHz 2.0 to 2.7 GHz		0.30 0.40 0.50		dB dB dB
Isolation (ANT pin to RF1/2/3/4/5/6 pins)	Iso	0.1 to 1.0 GHz 1.0 to 2.0 GHz 2.0 to 2.7 GHz	35 25 20	40 30 24		dB dB dB
Input return loss (ANT pin to RF1/2/3/4/5/6 pins)	RL	0.1 to 1.0 GHz 1.0 to 2.0 GHz 2.0 to 2.7 GHz	20 15 12	25 20 15		dB dB dB
0.1 dB Compression Point (ANT pin to RF1/2/3/4/5/6 pins)	P0.1dB	0.7 GHz to 3.0 GHz		+27		dBm
2 nd Harmonic	2f ₀	900MHz, 1800MHz, +10dBm	-73	-78		dBc
3 rd Harmonic	3f ₀	900MHz, 1800MHz, +10dBm	-93	-95		dBc

MIPI Read and Write Timing

MIPI supports the following Command Sequences:

- Register Write
- Register_0 Write
- Register Read

Figures 3 and 4 provide the timing diagrams for register write commands and read commands, respectively. Figure 5 shows the Register 0 Write Command Sequence. Refer to the MIPI Alliance Specification for RF Front-End Control Interface (RFFE), v1.10 (26 July 2011) for additional information on MIPI USID programming sequences and MIPI bus specifications.

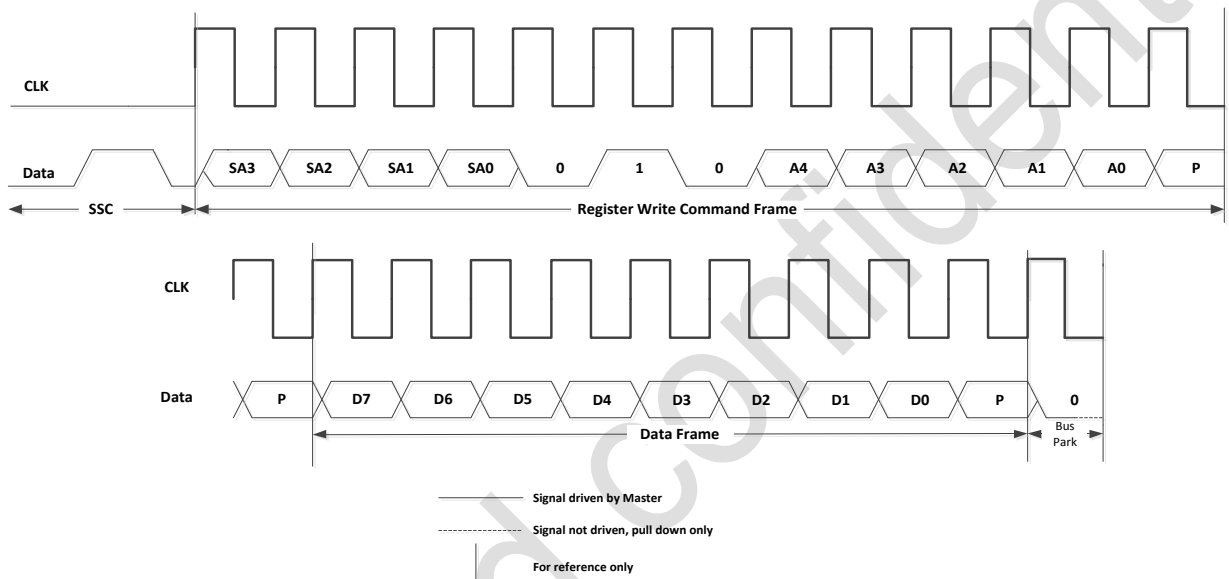

Figure 3. Register Write Command Sequence

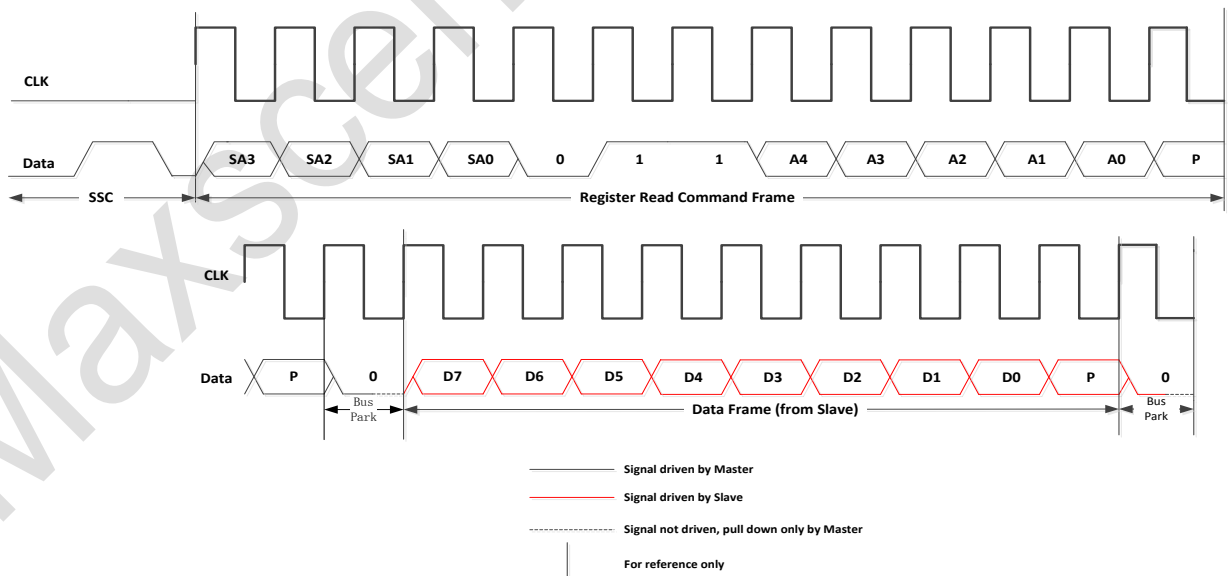

Figure 4. Register Read Command Sequence

In the timing figures, SA[3:0] is slave address. A[4:0] is register address. D[7:0] is data. “P” is odd parity bit.

Register 0 Write Command Sequence

Figure shows the Register 0 Write Command Sequence. The Command Sequence starts with an SSC, followed by the Register 0 Write Command Frame containing the Slave address, a logic one, and a seven bit word to be written to Register 0. The Command Sequence ends with a Bus Park Cycle.

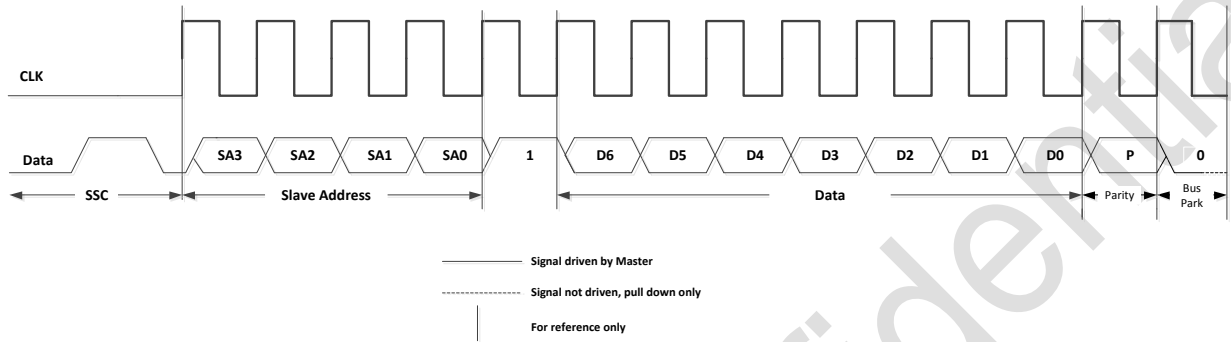

Figure 5. Register 0 Write Command Sequence

Maxscend Confidential

Register definition
Table 5. Register definition table

Register Address	Register Name	Data Bits	R/W	Function	Description	Default	BROADC AST_ID support	Trigger support
0x00	REGISTER_0	7:0	R/W	RF Control	Register_0 truth Table: Table 2	0x00	No	Yes
0x001A	RFFE_STATU S	7	R/W	SOFTWARE RESET	0: Normal operation 1: Software reset Note: On software reset, this register and all configurable registers are reset except for USID, GSID, and PM_TRIG.	0	No	No
		6	R/W	COMMAND_FR AME_PARITY_E RR	Command Frame with parity error	0	No	No
		5	R/W	COMMAND_LE NGTH_ERR	Command Sequence with incorrect length	0	No	No
		4	R/W	ADDRESS_FRA ME_PARITY_E RR	Address Frame with parity error	0	No	No
		3	R/W	DATA_FRAME_ PARITY_ERR	Data Frame with parity error	0	No	No
		2	R/W	READ_UNUSED _REG	Read Command Sequence to an invalid address	0	No	No
		1	R/W	WRITE_UNUSE D_REG	Write Command Sequence to an invalid address	0	No	No
		0	R/W	BID_GID_ERR	Read Command Sequence with a BSID or GSID Note: Reading this register resets this register.	0	No	No
0x001B	GROUP_SID	7:4	R	RESERVED		0x0	No	No
		3:0	R/W	GSID	Group Slave ID	0x0	No	No
0x001C	PM_TRIG	7:6	R/W	PWR_MODE	00: Normal Operation (ACTIVE) 01: Reset all registers to default settings (STARTUP) 10: Low power (LOW POWER) 11: Reserved Note: Write PWR_MODE=2'h1 will reset all register, and puts the device into STARTUP state.	0b10	Yes	No
		5	R/W	Trigger_Mask_2	If this bit is set, trigger 2 is disabled	0	No	No
		4	R/W	Trigger_Mask_1	If this bit is set, trigger 1 is disabled	0	No	No
		3	R/W	Trigger_Mask_0	If this bit is set, trigger 0 is disabled Note: When all triggers are disabled, writing to a register that is associated with trigger 0, 1, or 2, causes the data to go directly to the destination register.	0	No	No
		2	W	Trigger_2	A write of a one to this bit loads trigger 2's registers	0	Yes	No
		1	W	Trigger_1	A write of a one to this bit loads trigger 1's registers	0	Yes	No
		0	W	Trigger_0	A write of a one to this bit loads trigger 0's registers Note: Trigger processed immediately then cleared. Trigger 0, 1, and 2 will always read as 0.	0	Yes	No
0x001D	PRODUCT_ID	7:0	R	PRODUCT_ID	Product Number	0x5e	No	No
0x001E	MANUFACTU RER_ID	7:0	R	MANUFACTUR ER_ID[7:0]	Lower eight bits of MIPI registered Manufacturer ID	0x81	No	No
0x001F	MAN_USID	7:6	R	RESERVED		0b00	No	No
		5:4	R	MANUFACTUR ER_ID[9:8]	Upper two bits of MIPI registered Manufacturer ID	0b11	No	No
		3:0	R/W	USID	USID of the device.	0xb	No	No

Absolute Maximum Ratings
Table 6. Maximum ratings

Parameters	Symbol	Minimum	Maximum	Units
Supply voltage	V _{DD}	+2.0	+3.3	V
Supply voltage for MIPI	V _{IO}	+1.0	+2.0	V
MIPI Control voltage (SDATA, SCLK)	V _{CTL}	0	+2.0	V
RF input power (RF1 to RF6)	P _{IN}		+28	dBm
Operating temperature	T _{OP}	-20	+85	°C
Storage temperature	T _{STG}	-40	+125	°C
Electrostatic Discharge Human body model (HBM), Class 1C	ESD_HBM		1000	
Machine Model (MM), Class A	ESD_MM		100	V
Charged device model (CDM), Class III	ESD_CDM		500	

Note: Exposure to maximum rating conditions for extended periods may reduce device reliability. There is no damage to device with only one parameter set at the limit and all other parameters set at or below their nominal value. Exceeding any of the limits listed here may result in permanent damage to the device

Power ON and OFF sequence

Here is the recommendation about power-on/off sequence in order to avoid damaging the device.

Power ON

- 1) Apply voltage supply - V_{DD}
- 2) Apply logic supply - V_{IO}
- 3) Wait 10µs or greater and then apply MIPI bus signals – SCLK and SDATA
- 4) Wait 5µs or greater after MIPI bus goes idle and then apply the RF Signal

Power OFF

- 1) Remove the RF Signal
- 2) Remove MIPI bus – SCLK and SDATA
- 3) Remove logic supply - V_{IO}
- 4) Remove voltage supply - V_{DD}

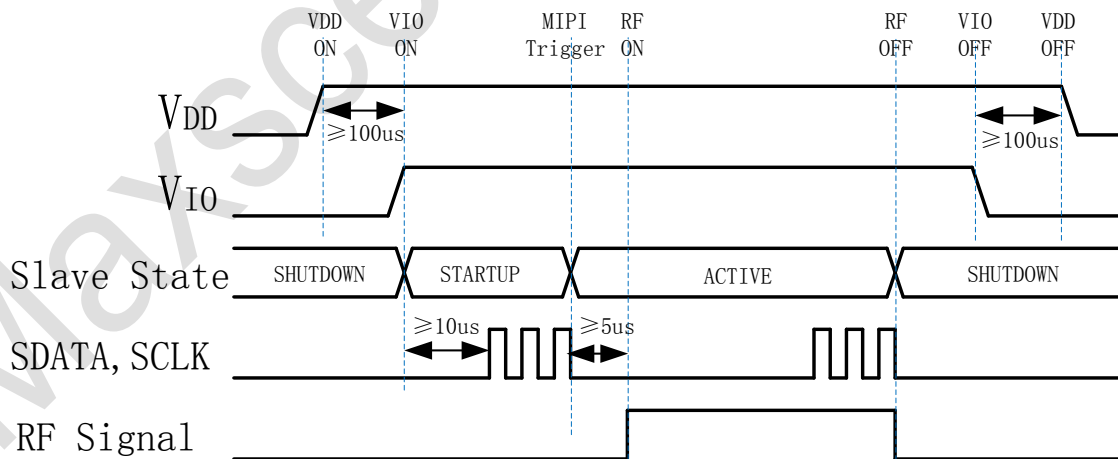

Note: V_{IO} can be applied to the device before V_{DD} or removed after V_{DD}.

It is important to wait 10µs after V_{IO} & V_{DD} are applied before sending SDATA to ensure correction data transmission.

The minimum time between a power up and power down sequence (and vice versa) is ≥ 100µs.

Package Outline Dimension

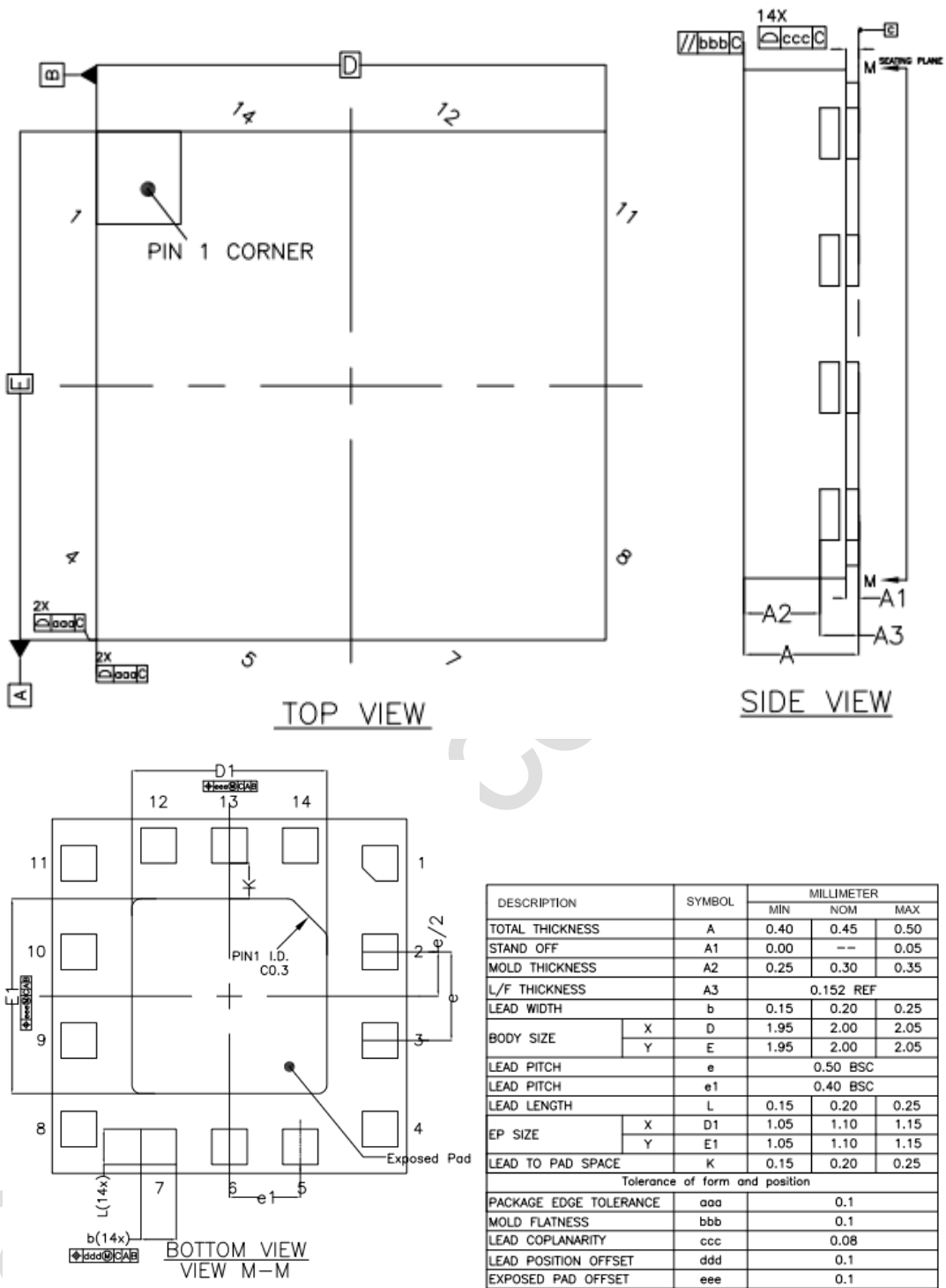

Figure 6. package outline dimension

Reflow Chart

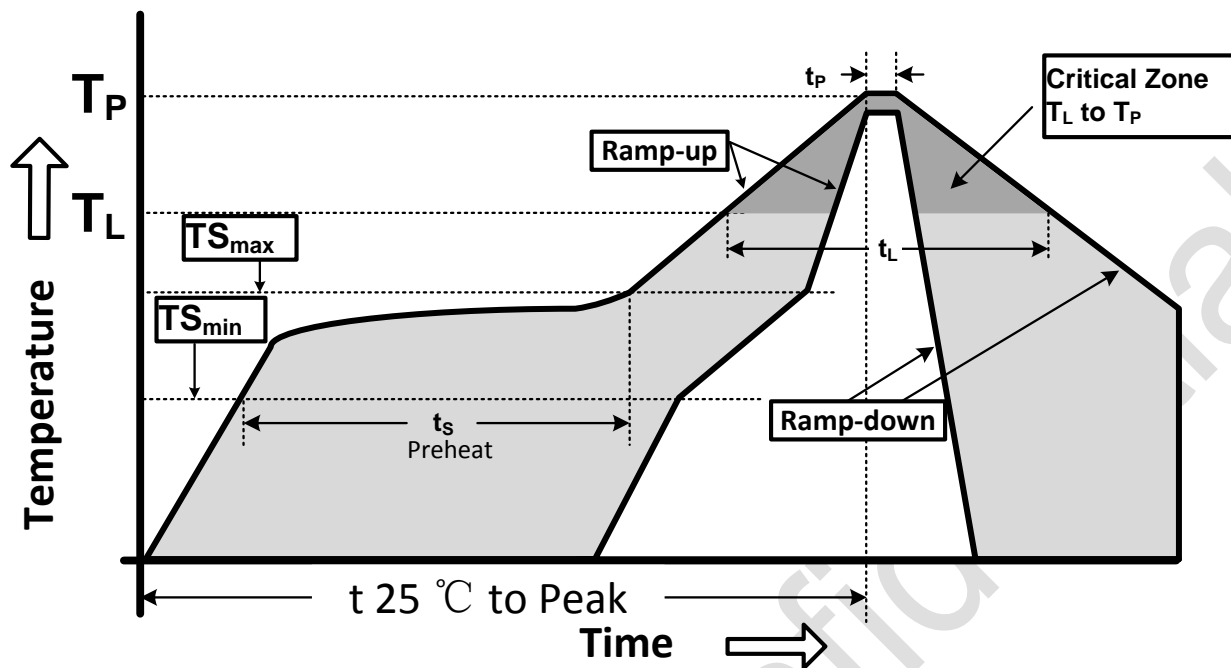

Figure 7. Recommended Lead-Free Reflow Profile

Table 7. Reflow condition

Profile Parameter	Lead-Free Assembly, Convection, IR/Convection
Ramp-up rate (TS_{max} to T_p)	3°C/second max.
Preheat temperature (TS_{min} to TS_{max})	150°C to 200°C
Preheat time (t_s)	60 - 180 seconds
Time above T_L , 217°C (t_L)	60 - 150 seconds
Peak temperature (T_p)	260°C
Time within 5°C of peak temperature(t_p)	20 - 40 seconds
Ramp-down rate	6°C/second max.
Time 25°C to peak temperature	8 minutes max.

ESD Sensitivity

Integrated circuits are ESD sensitive and can be damaged by static electric charge. Proper ESD protection techniques should be used when handling these devices.

RoHS Compliant

This product does not contain lead, mercury, cadmium, hexavalent chromium, polybrominated biphenyls (PBB) and polybrominated diphenyl ethers (PBDE), and are considered RoHS compliant.