

N SERIES

RF CO-AXIAL CONNECTORS

Overview

The N series of connectors are medium-sized, weather-resistant constant-impedance coaxial connectors of the screw-coupling type, suited for use with medium-sized coaxial cables. Their rated voltage is 500V (rms). The nominal impedance is 50Ω, and they can be used with frequencies of up to 10GHz. At low frequencies, they can be used with 75Ω cables. They are suited primarily for coaxial cables RG-5, 6, 8, 9/U, etc.

The N series has been approved in Defense Agency specification DSP C 6201.

Main materials used

Parts	Materials	Finish
Armor (shell)	Brass	Silver plating + surface treatment
Outer contacts	Phosphor bronze	Silver plating + surface treatment
Male ends	Brass	Silver plating + surface treatment
Female ends	Beryllium copper	Silver plating + surface treatment
Insulation	Tetrafluoride resin	
Packing	Silicone rubber	

Main performance characteristics

Items	Standard value
Contact resistance	3mΩ or less (at 1A DC)
Insulation resistance	1000MΩ or more at 500V DC
Withstand voltage	1500V AC (rms) for 1 minute
Characteristic impedance	50Ω

N-P plugs

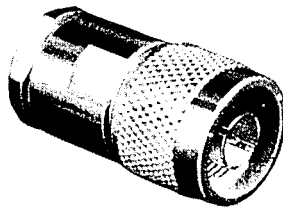

UG-21D/U

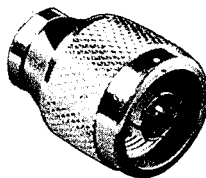

N-P-141

HRS No.	Part No.	Applicable cable	φ D	φ d	L	Remarks
CL301-0002-7	UG-18C/U	RG-5.6.21/U	8.7	19.0	38	
*CL301-0003-0	UG-21D/U	RG-8.9/U	11.1	19.0	38	
CL301-0022-4	UG-204C/U	RG-14/U	14.1	22.2	45	
*CL301-0001-4	JUG-536/U	RG-58/U	5.4	19.0	38	For low-voltage use: Withstand voltage: 500V
CL301-0078-9	N-P-3DV	3D-2V	6.3	12.7	35	
*CL301-0120-3	N-P-5DV	5D-2V	8.6	18.0	45.5	
CL301-0116-6	N-P-8DV	8D-2V	12.6	23.0	51	
CL301-0199-3	N-P-5DW	5D-2W	9.3	18	46	
CL301-0205-4	N-P-5DFB	5D-FB	8.6	18	46	
CL301-0206-7	N-P-10DFB	10D-FB	14.5	23	55	

*Standard product

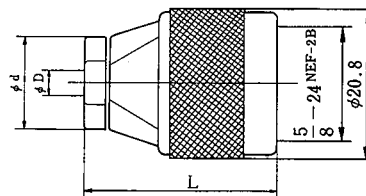
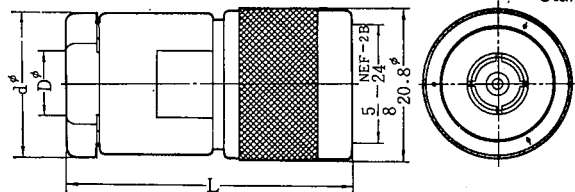

HRS No.	Part No.	Applicable cable	φ D	φ d	L
*CL301-0162-3	N-P-141	UT-141A	3.63	13	27.3

*Standard product

N SERIES

RF CO-AXIAL CONNECTORS

L-Shaped Plug

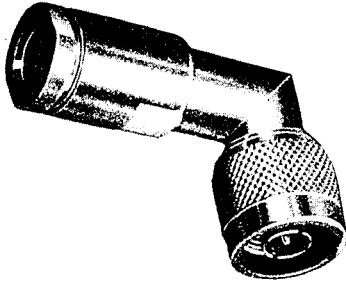

N-LP-5DW

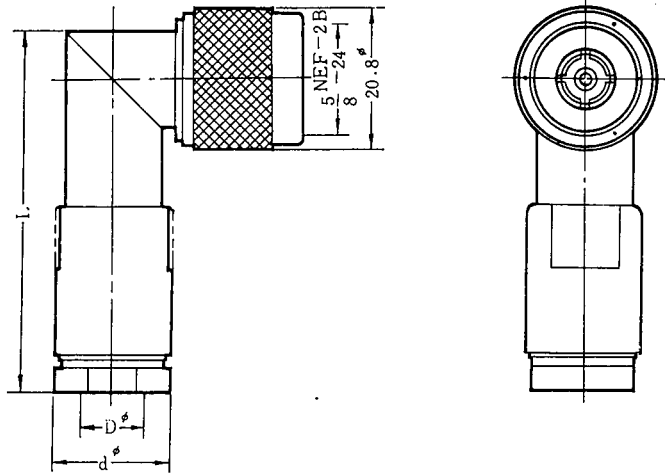

HRS No.	Part No.	Applicable cables	φD	φd	L	Remarks
CL301-0007-0	N-LP-5DW	5D-2W	9.3	17.5	52.4	Nickel-plated except for center conductor
CL301-0076-3	N-LP-58U	RG-58/U	5.3	15.5	44.0	

Jack

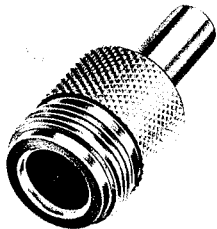

N-J-3DW

HRS No.	Part No.	Applicable cable	φA
CL301-0179-6	N-J-3DW	3D-XW Irrax	4.3
CL301-0180-5	N-J-3DV	3D-2V	5.1

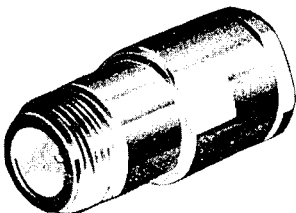
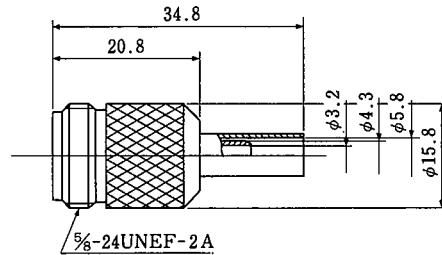

UG-23D/U

HRS No.	Part No.	Applicable cable	φD	φd	L
CL301-0008-3	UG-23D/U	RG-8,9/U	11.1	19.0	39.7

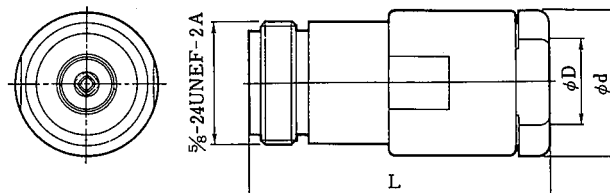

N SERIES

RF CO-AXIAL CONNECTORS

Panel-Jack

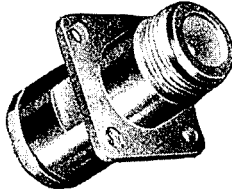

UG-22D/U

HRS No.	Part No.	Applicable cables	ϕD	ϕd	L	$\square S$
CL301-0010-5	UG-22D/U	RG-8,9/U	11.1	19.0	39.7	18.24
*CL301-0011-8	N-PJ-58/U	RG-58/U	5.4	14.6	41.5	18.2

*Standard product

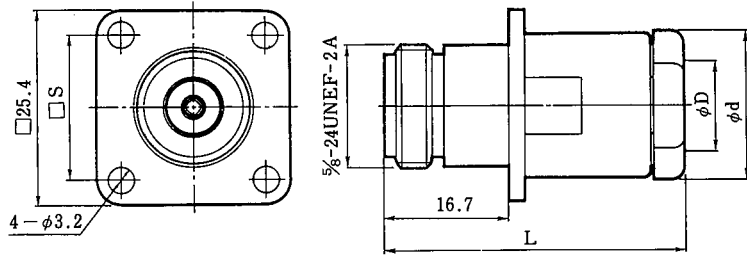

Receptacle

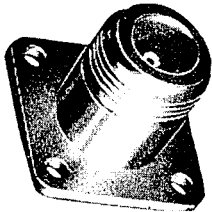

UG-58A/U

HRS No.	Part No.
*CL301-0012-0	UG-58A/U

*Standard product

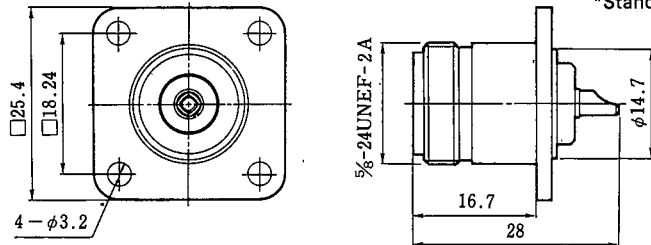

Adapter

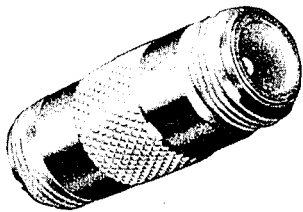

UG-29B/U

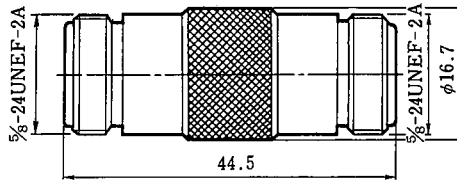

JJ

HRS No.	Part No.
CL301-0035-6	UG-29B/U

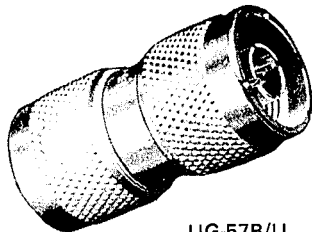

UG-57B/U

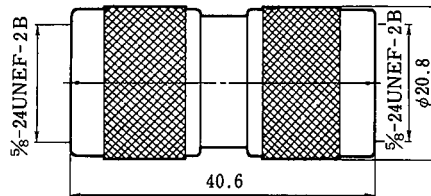

PP

HRS No.	Part No.
CL301-0018-7	UG-57B/U

N SERIES

RF CO-AXIAL CONNECTORS

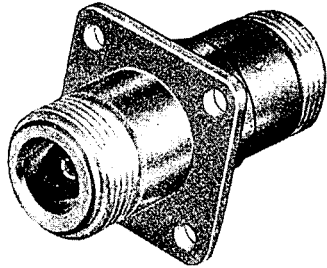

N-PA

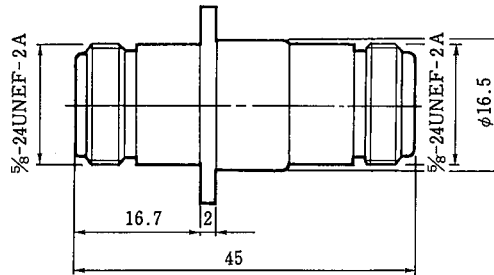

HRS No.	Part No.
CL301-0036-9	N-PA

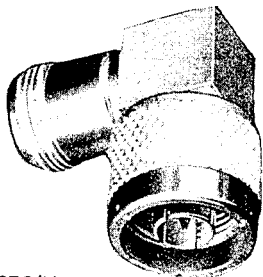
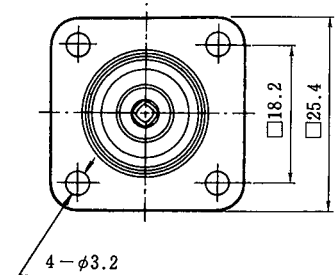

UG-27C/U

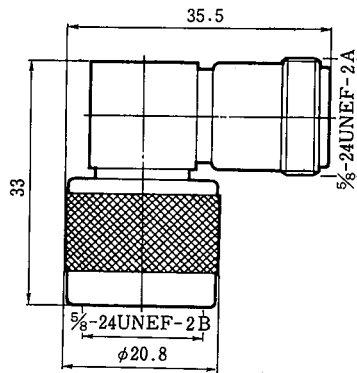

HRS No.	Part No.
CL301-0015-9	UG-27C/U

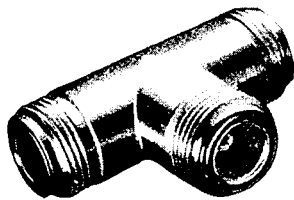

UG-28A/U

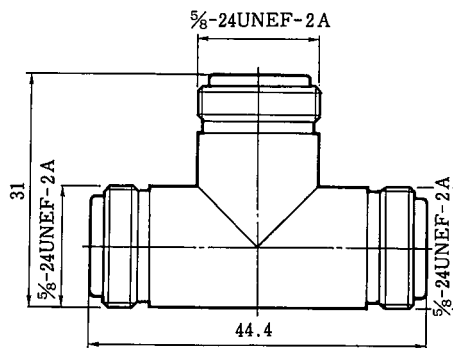

JJJ

HRS No.	Part No.
CL301-0017-4	UG-28A/U

JPJ

HRS No.	Part No.
CL301-0016-1	UG-107B/U

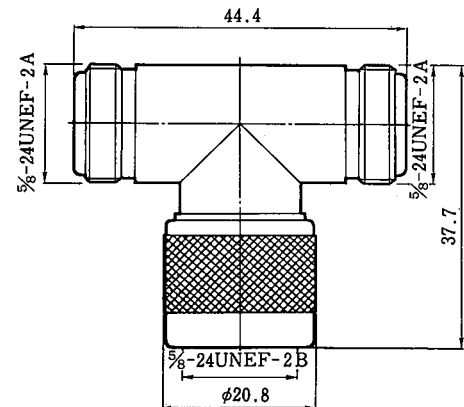

N SERIES

RF CO-AXIAL CONNECTORS

Cap

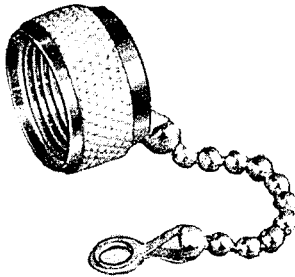

MX-913/U

HRS No.	Part No.
CL301-0020-9	MX-913/U

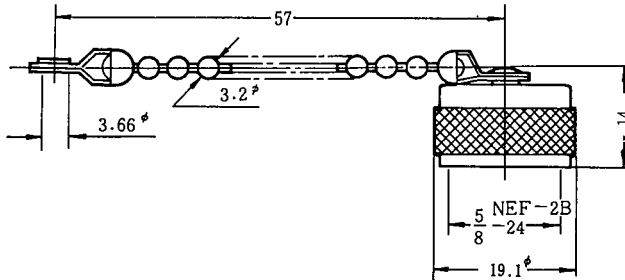

Functional drawing

Typical product numbers are enclosed in parentheses.

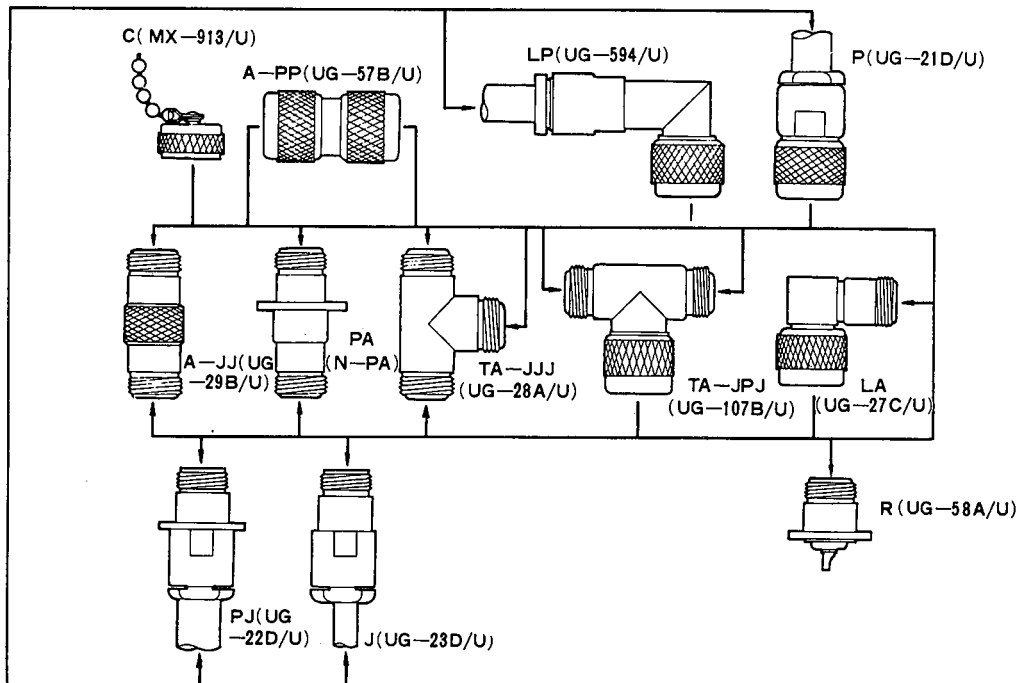

Connecting methods

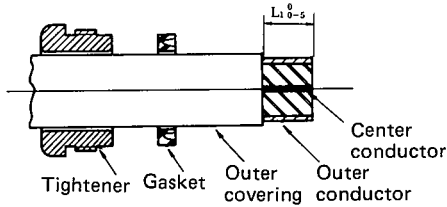

The cable ends are processed as shown in the drawing (refer to Table 1). For the end processing dimensions L_1 , refer to Table 1, End processing dimensions arranged by part number.

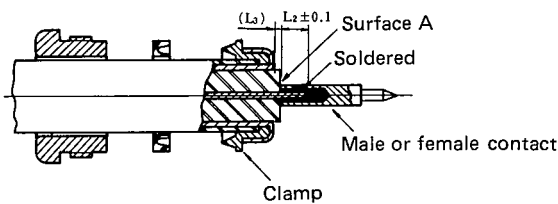

- (1) Insert clamp from tip of cable and fold outer conductor of cable back onto clamp. Using a knife, cut off excess outer conductor left at this time.
- (2) Cut off center conductor of cable at L_2 , from surface A of cable insulation. For end processing dimensions L_2 , L_3 , refer to Table 1, End processing dimensions arranged by part number. (L_3 is a reference dimension.)
(Note: Be careful not to damage center conductor.)
- (3) Solder contact and center conductor. It is a good idea at this time to solder the contact preliminarily in advance.
(Note: There must be no gap between the contact and the cable insulation.)

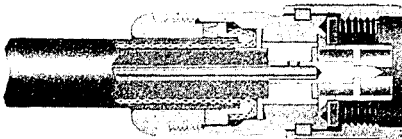

Insert cable and parts into shell and fit sharp end of clamp completely into V-shaped surface of gasket. Tighten tightening nut sufficiently.

■ Remarks

1. The cable end processing dimensions are those of general connectors based on the MIL and DSP standards. They may differ somewhat depending on the type of cable. In such cases, match the dimensions with the connectors.
2. Some clamps and gaskets are not V-shaped, but the connecting procedures are the same.

Table 1 and processing dimensions arranged by part number

Unit: mm

HRS No.	Part No.	$L_1 \pm 0.5$	$L_2 \pm 0.1$	L_3
*CL301-0001-4	JUG-536/U	8.6	6	1
CL301-0002-7	UG-18C/U	9.6	6	1
*CL301-0003-0	UG-21D/U	10.0	6	1
CL301-0007-0	N-LP-5DW	11.5	4	3.5
CL301-0008-3	UG-23D/U	8.5	5	1
CL301-0010-5	UG-22D/U	8.5	5	1
*CL301-0011-8	N-PJ-58/U	7.4	3	3.2
CL301-0022-4	UG-204C/U	11.5	6	2
CL301-0076-3	N-LP-58U	9.2	4	3.6
CL301-0078-9	N-P-3DV	12.3	6	4.8
CL301-0116-6	N-P-8DV	12.3	5.5	3
*CL301-0120-3	N-P-5DV	11.1	6	1.5
CL301-0199-3	N-P-5DW	12.0	6	1.5
CL301-0205-4	N-P-5DFB	11.0	6	5
CL301-0206-7	N-P-10DFB	11.0	6	5

*Standard product