

## TFT LCD Approval Specification

# MODEL NO.: N101L6

# Suffix:-L0C

Customer : \_\_\_\_\_ Common Model \_\_\_\_\_

Approved by : \_\_\_\_\_

Note : Bracket H:245mm

核准時間	部門	審核	角色	投票
2010-04-12 09:59:39	NB 產品管理處		Director	Accept

## - CONTENTS -

REVISION HISTORY	-----	3
1. GENERAL DESCRIPTION	-----	4
1.1 OVERVIEW		
1.2 FEATURES		
1.3 APPLICATION		
1.4 GENERAL SPECIFICATIONS		
1.5 MECHANICAL SPECIFICATIONS		
2. ABSOLUTE MAXIMUM RATINGS	-----	5
2.1 ABSOLUTE RATINGS OF ENVIRONMENT		
2.2 ELECTRICAL ABSOLUTE RATINGS		
2.2.1 TFT LCD MODULE		
2.2.2 BACKLIGHT UNIT		
3. ELECTRICAL CHARACTERISTICS	-----	7
3.1 TFT LCD MODULE		
3.2 BACKLIGHT UNIT		
4. BLOCK DIAGRAM	-----	10
4.1 TFT LCD MODULE		
5. INPUT TERMINAL PIN ASSIGNMENT	-----	11
5.1 TFT LCD MODULE		
5.2 TIMING DIAGRAM OF LVDS INPUT SIGNAL		
5.3 COLOR DATA INPUT ASSIGNMENT		
5.4 EDID CODE DATA STRUCTURE		
6. CONVERTER SPECIFICATION	-----	17
6.1 ABSOLUTE MAXIMUM RATINGS		
6.2 RECOMMENDED OPERATING RATINGS		
6.3 LED BACKLIGHT CONTROLLER ON/OFF SEQUENCE		
7. INTERFACE TIMING	-----	19
7.1 INPUT SIGNAL TIMING SPECIFICATIONS		
7.2 POWER ON/OFF SEQUENCE		
8. OPTICAL CHARACTERISTICS	-----	22
8.1 TEST CONDITIONS		
8.2 OPTICAL SPECIFICATIONS		
9. PRECAUTIONS	-----	26
9.1 SYSTEM MATCHING PRECAUTIONS		
9.2 HANDLING PRECAUTIONS		
9.3 STORAGE PRECAUTIONS		
9.4 OPERATION PRECAUTIONS		
9.5 OTHER PRECAUTIONS		
10. PACKING	-----	27
10.1 CARTON		
10.2 PALLET		
11. DEFINITION OF LABELS	-----	29
11.1 CMO MODULE LABEL		
11.2 CMO CARTON LABEL		
12. Mechanical Drawing	-----	31

REVISION HISTORY

Version	Date	Page (New)	Section	Description
Ver. 3.0	Apr. 12, 2010	All	All	Approval specification is first issued.

## 1. GENERAL DESCRIPTION

### 1.1 OVERVIEW

N101L6 Suffix:-LOC is a 10.06" TFT Liquid Crystal Display module with LED Backlight unit and 40 pins LVDS interface. This module supports 1024 x 600 Wide-SVGA mode and can display 262,144 colors. The optimum viewing angle is at 6 o'clock direction. The converter module for Backlight is built in.

### 1.2 FEATURES

- WSVGA (1024 x 600 pixels) resolution
- Thin, light and low power consumption
- DE only mode
- 3.3V LVDS (Low Voltage Differential Signaling) interface with 1 pixel/clock
- LED converter embedded

### 1.3 APPLICATION

- TFT LCD Notebook

### 1.4 GENERAL SPECIFICATIONS

Item	Specification	Unit	Note
Active Area	222.72 (H) x 125.28 (V) (10.06" diagonal)	mm	(1)
Opening Area	225.72 (H) x 128.28 (V)	mm	
Driver Element	a-si TFT active matrix	-	-
Pixel Number	1024 x R.G.B. x 600	pixel	-
Pixel Pitch	0.2175 (H) x 0.2088 (V)	mm	-
Pixel Arrangement	RGB vertical stripe	-	-
Display Colors	262,144	color	-
Transmissive Mode	Normally white	-	-
Surface Treatment	Haze 25%(3H), AG	-	-

### 1.5 MECHANICAL SPECIFICATIONS

Item		Min.	Typ.	Max.	Unit	Note
Module Size	Horizontal(H) With Bracket	244.5	245	245.5	mm	(1)
	Horizontal(H) W/o Bracket	232.5	233	233.5	mm	
	Vertical(V) With PCB	146.0	146.5	147.0	mm	
	Vertical(V) W/o PCB	136.5	137	137.5	mm	
	Thickness(T)	-	3.3	3.6	mm	
Weight		-	160	170	g	

Note (1) Please refer to the attached drawings for more information of front and back outline dimensions.

## 2. ABSOLUTE MAXIMUM RATINGS

### 2.1 ABSOLUTE RATINGS OF ENVIRONMENT

Item	Symbol	Value		Unit	Note
		Min.	Max.		
Storage Temperature	T <sub>ST</sub>	-20	+60	°C	(1)
Operating Ambient Temperature	T <sub>OP</sub>	0	+50	°C	(1), (2)
Shock (Non-Operating)	S <sub>NOP</sub>	-	220/2	G/ms	(3), (5)
Vibration (Non-Operating)	V <sub>NOP</sub>	-	1.5	G	(4), (5)

Note (1) (a) 90 %RH Max. (Ta ≤ 40 °C).

(b) Wet-bulb temperature should be 39 °C Max. (Ta > 40 °C).

(c) No condensation.

Note (2) The temperature of panel display surface area should be 0 °C Min. and 50 °C Max.

#### Relative Humidity (%RH)

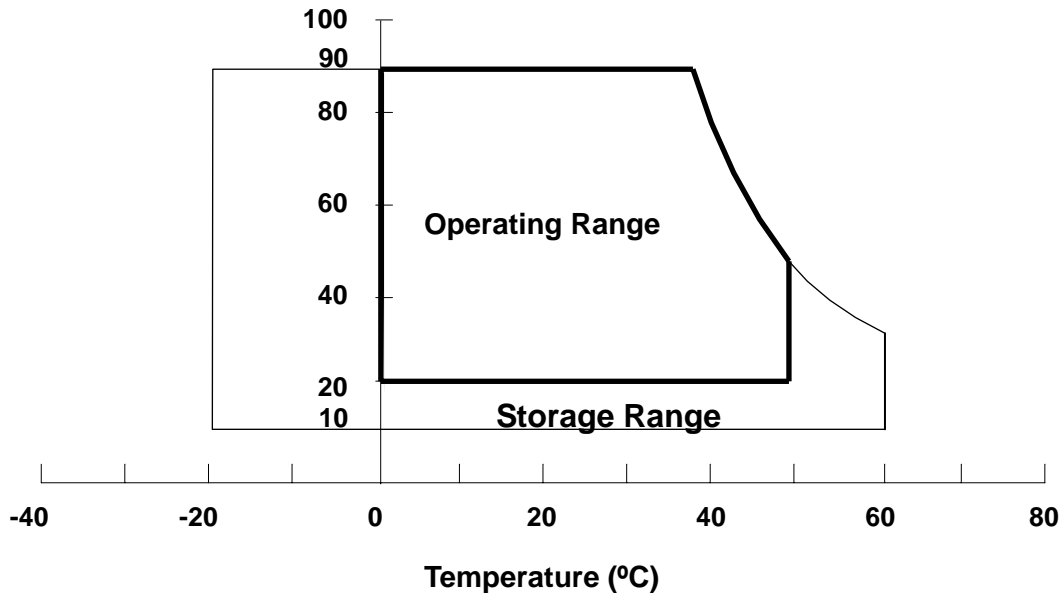

Note (3) 1 time for ± X, ± Y, ± Z. for Condition (220G / 2ms) is half Sine Wave,.

Note (4) 10 ~ 500 Hz, 30 min/cycle, 1 cycles for each X, Y, Z axis.

Note (5) At testing Vibration and Shock, the fixture in holding the module has to be hard and rigid enough so that the module would not be twisted or bent by the fixture.

The fixing condition is shown as below:

At Room Temperature

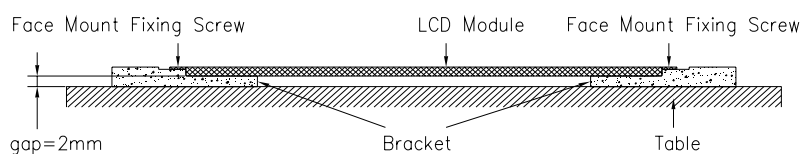

## 2.2 ELECTRICAL ABSOLUTE RATINGS

### 2.2.1 TFT LCD MODULE

Item	Symbol	Value		Unit	Note
		Min.	Max.		
Power Supply Voltage	VCCS	-0.3	+4.0	V	(1)
Logic Input Voltage	V <sub>I</sub>	-0.3	VCCS+0.3	V	

Note (1) Permanent damage to the device may occur if maximum values are exceeded. Function operation should be restricted to the conditions described under Normal Operating Conditions.

### 2.2.2 BACKLIGHT UNIT

Item	Value		Unit	Note
	Min	Max.		
LED Light Bar Power Supply Voltage	-40	27.2	V	(1), (2)
LED Light Bar Power Supply Current	0	75	mA	

Note (1) Permanent damage to the device may occur if maximum values are exceeded. Function operation should be restricted to the conditions described under Normal Operating Conditions.

Note (2) Specified values are for LED (Refer to 3.2 for further information).

### 3. ELECTRICAL CHARACTERISTICS

#### 3.1 TFT LCD MODULE

Ta = 25 ± 2 °C

Parameter	Symbol	Value			Unit	Note
		Min.	Typ.	Max.		
Power Supply Voltage	VCCS	3.0	3.3	3.6	V	-
Ripple Voltage	V <sub>RP</sub>	-	-	100	mV	-
Rush Current	I <sub>RUSH</sub>	-	-	1.5	A	(2)
Initial Stage Current	I <sub>IS</sub>	-	-	1.0	A	(2)
Power Supply Current	I <sub>CC</sub>	White	140	160	mA	(3)a
		Black	160	180	mA	(3)b
LVDS Differential Input High Threshold	V <sub>TH(LVDS)</sub>	-	-	+100	mV	(4), V <sub>CM</sub> =1.2V
LVDS Differential Input Low Threshold	V <sub>TL(LVDS)</sub>	-100	-	-	mV	(4) V <sub>CM</sub> =1.2V
LVDS Common Mode Voltage	V <sub>CM</sub>	1.125	-	1.375	V	(4)
LVDS Differential Input Voltage	V <sub>ID</sub>	100	-	600	mV	(4)
Terminating Resistor	R <sub>T</sub>	-	100	-	Ohm	-
Power per EBL WG	PEBL	-	0.964	-	W	(5)

Note (1) The ambient temperature is Ta = 25 ± 2 °C.

Note (2) I<sub>RUSH</sub>: the maximum current when VCCS is rising

I<sub>IS</sub>: the maximum current of the first 100ms after power-on

Measurement Conditions: Shown as the following figure. Test pattern: black.

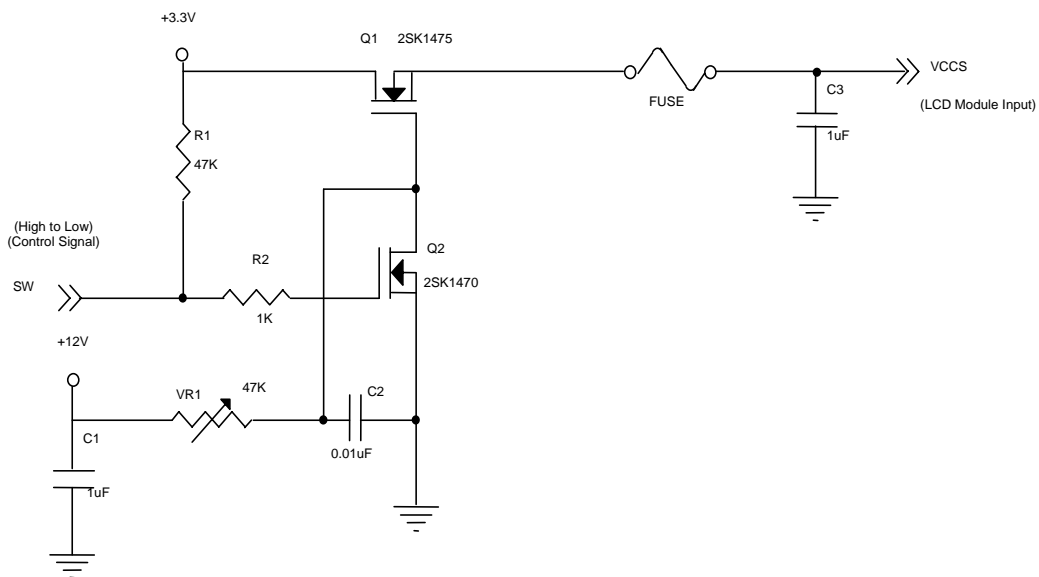

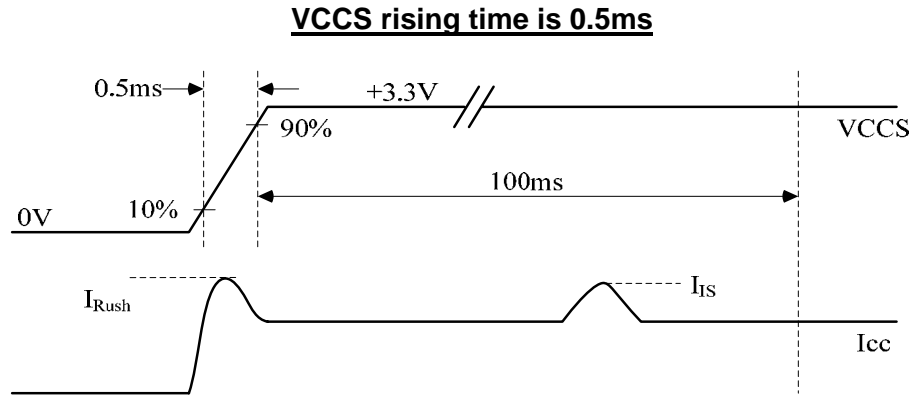

Note (3) The specified power supply current is under the conditions at VCCS = 3.3 V,  $T_a = 25 \pm 2 \text{ }^\circ\text{C}$ ,  $f_v = 60 \text{ Hz}$ , whereas a power dissipation check pattern below is displayed.

a. White Pattern



Active Area

b. Black Pattern



Active Area

Note (4) The parameters of LVDS signals are defined as the following figures.

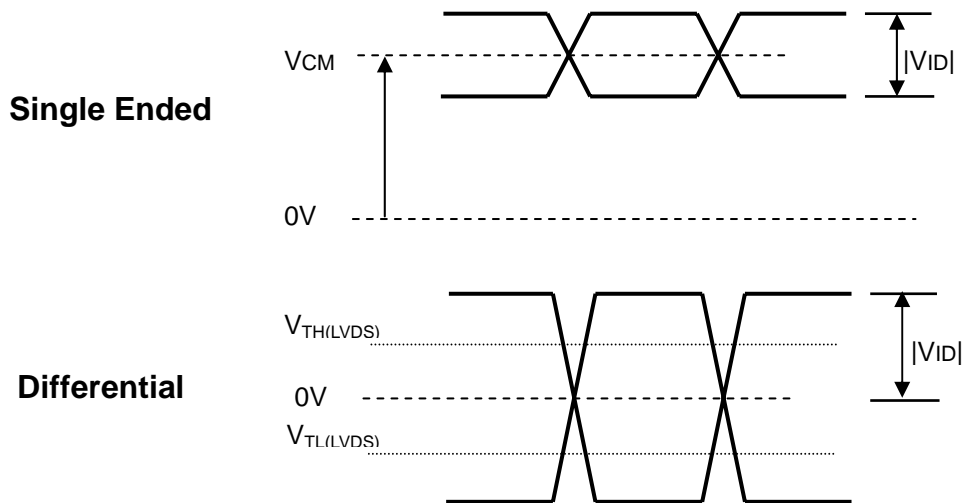



Note (5) The specified power are the sum of LCD panel electronics input power and the converter input power. Test conditions are as follows.

- (a) VCCS = 3.3 V, Ta = 25 ± 2 °C, f<sub>v</sub> = 60 Hz,
- (b) The pattern used is a black and white 32 x 36 checkerboard, slide #100 from the VESA file "Flat Panel Display Monitor Setup Patterns", FPDMSU.ppt.
- (c) Luminance: 60 nits.

### 3.2 BACKLIGHT UNIT

Ta = 25 ± 2 °C

Parameter	Symbol	Value			Unit	Note
		Min.	Typ.	Max.		
LED Light Bar Power Supply Voltage	V <sub>L</sub>	23.2	25.6	27.2	V	(1),(2) (Duty 100%)
LED Light Bar Power Supply Current	I <sub>L</sub>	57	60	63	mA	
Power Consumption	P <sub>L</sub>	1.32	1.54	1.71	W	(3)
LED Life Time	L <sub>BL</sub>	12000	--	--	Hrs	(4)

Note (1) LED current is measured by utilizing a high frequency current meter as shown below :

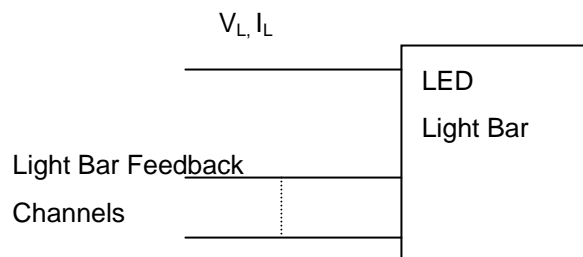

Note (2) For better LED light bar driving quality, it is recommended to utilize the adaptive boost converter with current balancing function to drive LED light-bar.

Note (3)  $P_L = I_L \times V_L$

Note (4) The lifetime of LED is defined as the time when it continues to operate under the conditions at Ta = 25 ± 2 °C and I<sub>L</sub> = 20 mA(Per EA) until the brightness becomes 50% of its original value.

4. BLOCK DIAGRAM

4.1 TFT LCD MODULE

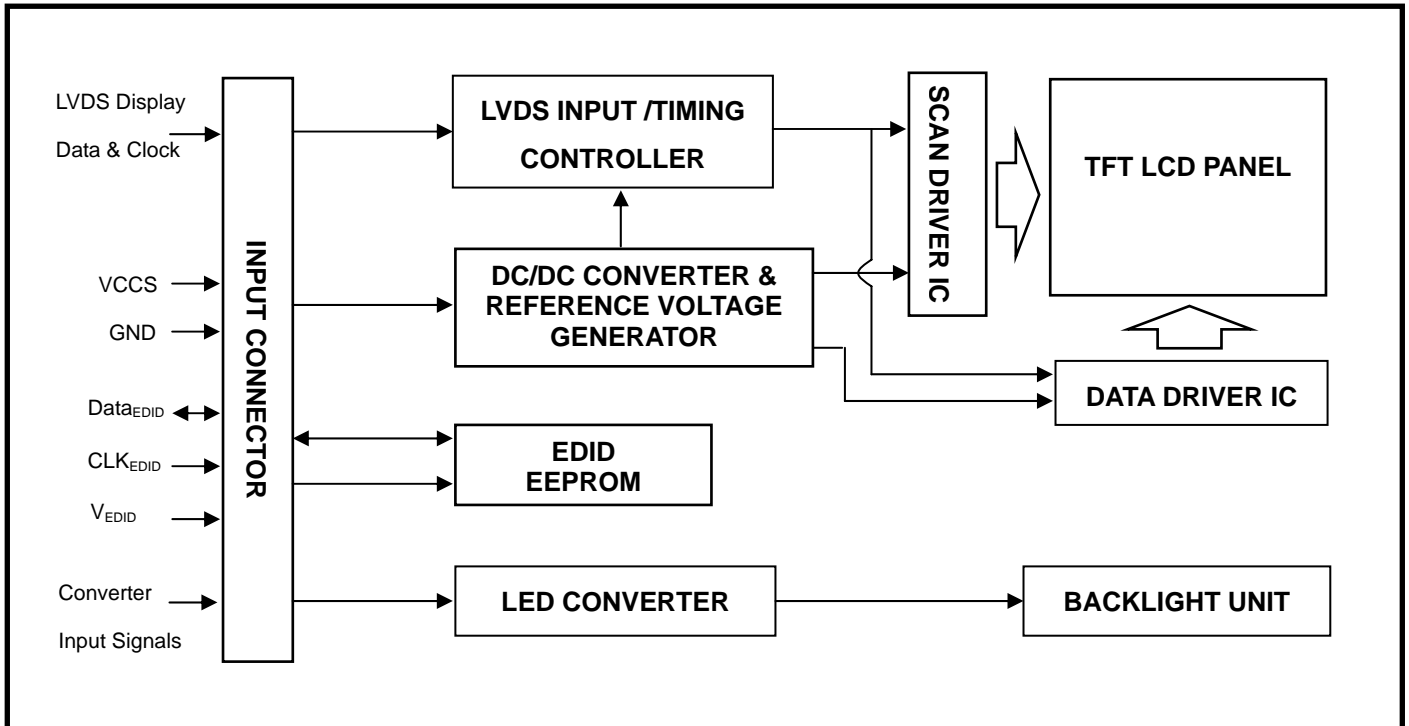

## 5. INPUT TERMINAL PIN ASSIGNMENT

### 5.1 TFT LCD MODULE

Pin	Symbol	Description	Polarity	Remark
1	NC	No Connection (Reserve)		
2	VCCS	Power Supply (3.3V typ.)		
3	VCCS	Power Supply (3.3V typ.)		
4	VEDID	DDC 3.3V power		
5	NC	No Connection (Reserve)		
6	CLKEDID	DDC clock		
7	DATAEDID	DDC data		
8	Rxin0-	LVDS differential data input	Negative	R0-R5, G0
9	Rxin0+	LVDS differential data input	Positive	
10	VSS	Ground		
11	Rxin1-	LVDS differential data input	Negative	G1~G5, B0, B1
12	Rxin1+	LVDS differential data input	Positive	
13	VSS	Ground		
14	Rxin2-	LVDS Differential Data Input	Negative	B2-B5,HS,VS, DE
15	Rxin2+	LVDS Differential Data Input	Positive	
16	VSS	Ground		
17	RxCLK-	LVDS differential clock input	Negative	
18	RxCLK+	LVDS differential clock input	Positive	
19	VSS	Ground		
20	NC	No Connection (Reserve)		
21	NC	No Connection (Reserve)		
22	VSS	Ground		
23	NC	No Connection (Reserve)		
24	NC	No Connection (Reserve)		
25	VSS	Ground		
26	NC	No Connection (Reserve)		
27	NC	No Connection (Reserve)		
28	VSS	Ground		
29	NC	No Connection (Reserve)		
30	NC	No Connection (Reserve)		
31	LED_GND	LED Ground		
32	LED_GND	LED Ground		
33	LED_GND	LED Ground		
34	NC	No Connection (Reserve)		
35	LED_PWM	PWM Control Signal of LED Converter		
36	LED_EN	Enable Control Signal of LED Converter		
37	NC	No Connection (Reserve)		
38	LED_VCCS	LED Power		
39	LED_VCCS	LED Power		
40	LED_VCCS	LED Power		

Note (1) Connector Part No.: IPEX 20455-040E-12 , Tyco 5-2069716-3 , Starconn 111A40-000RA-G3

or equivalent

Note (2) User's connector Part No: IPEX 20453-040T-01 or equivalent

Note (3) The first pixel is odd as shown in the following figure.

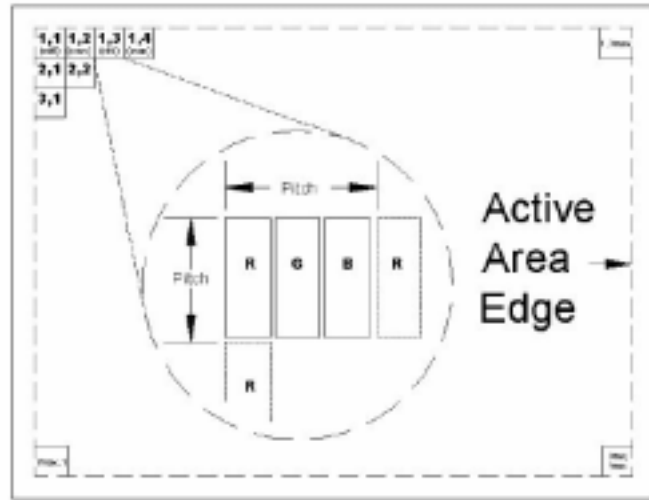

5.2 TIMING DIAGRAM OF LVDS INPUT SIGNAL

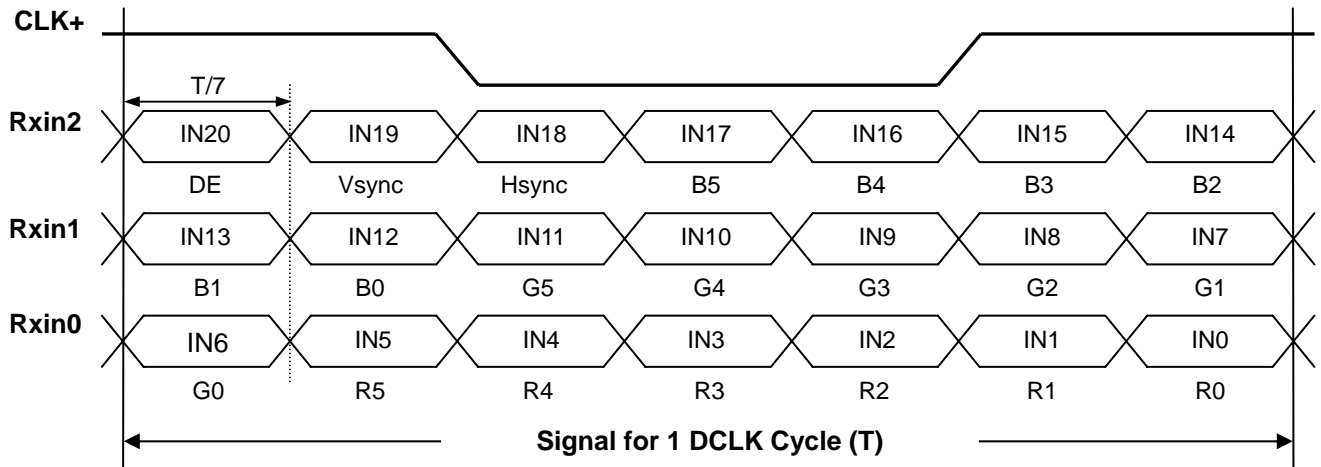

### 5.3 COLOR DATA INPUT ASSIGNMENT

The brightness of each primary color (red, green and blue) is based on the 6-bit gray scale data input for the color. The higher the binary input, the brighter the color. The table below provides the assignment of color versus data input.

Color		Data Signal																	
		Red						Green						Blue					
		R5	R4	R3	R2	R1	R0	G5	G4	G3	G2	G1	G0	B5	B4	B3	B2	B1	B0
Basic Colors	Black	0	0	0	0	0	0	0	0	0	0	0	0	0	0	0	0	0	0
	Red	1	1	1	1	1	1	0	0	0	0	0	0	0	0	0	0	0	0
	Green	0	0	0	0	0	0	1	1	1	1	1	1	0	0	0	0	0	0
	Blue	0	0	0	0	0	0	0	0	0	0	0	0	1	1	1	1	1	1
	Cyan	0	0	0	0	0	0	1	1	1	1	1	1	1	1	1	1	1	1
	Magenta	1	1	1	1	1	1	0	0	0	0	0	0	1	1	1	1	1	1
	Yellow	1	1	1	1	1	1	1	1	1	1	1	1	0	0	0	0	0	0
	White	1	1	1	1	1	1	1	1	1	1	1	1	1	1	1	1	1	1
Gray Scale Of Red	Red(0)/Dark	0	0	0	0	0	0	0	0	0	0	0	0	0	0	0	0	0	0
	Red(1)	0	0	0	0	0	1	0	0	0	0	0	0	0	0	0	0	0	0
	Red(2)	0	0	0	0	1	0	0	0	0	0	0	0	0	0	0	0	0	0
	:	:	:	:	:	:	:	:	:	:	:	:	:	:	:	:	:	:	:
	:	:	:	:	:	:	:	:	:	:	:	:	:	:	:	:	:	:	:
	:	:	:	:	:	:	:	:	:	:	:	:	:	:	:	:	:	:	:
	Red(61)	1	1	1	1	0	1	0	0	0	0	0	0	0	0	0	0	0	0
	Red(62)	1	1	1	1	1	0	0	0	0	0	0	0	0	0	0	0	0	0
Red(63)	1	1	1	1	1	1	0	0	0	0	0	0	0	0	0	0	0	0	
Gray Scale Of Green	Green(0)/Dark	0	0	0	0	0	0	0	0	0	0	0	0	0	0	0	0	0	0
	Green(1)	0	0	0	0	0	0	0	0	0	0	0	1	0	0	0	0	0	0
	Green(2)	0	0	0	0	0	0	0	0	0	0	1	0	0	0	0	0	0	0
	:	:	:	:	:	:	:	:	:	:	:	:	:	:	:	:	:	:	:
	:	:	:	:	:	:	:	:	:	:	:	:	:	:	:	:	:	:	:
	:	:	:	:	:	:	:	:	:	:	:	:	:	:	:	:	:	:	:
	Green(61)	0	0	0	0	0	0	1	1	1	1	0	1	0	0	0	0	0	0
	Green(62)	0	0	0	0	0	0	1	1	1	1	1	0	0	0	0	0	0	0
Green(63)	0	0	0	0	0	0	1	1	1	1	1	1	0	0	0	0	0	0	
Gray Scale Of Blue	Blue(0)/Dark	0	0	0	0	0	0	0	0	0	0	0	0	0	0	0	0	0	0
	Blue(1)	0	0	0	0	0	0	0	0	0	0	0	0	0	0	0	0	0	1
	Blue(2)	0	0	0	0	0	0	0	0	0	0	0	0	0	0	0	0	1	0
	:	:	:	:	:	:	:	:	:	:	:	:	:	:	:	:	:	:	:
	:	:	:	:	:	:	:	:	:	:	:	:	:	:	:	:	:	:	:
	:	:	:	:	:	:	:	:	:	:	:	:	:	:	:	:	:	:	:
	Blue(61)	0	0	0	0	0	0	0	0	0	0	0	0	1	1	1	1	0	1
	Blue(62)	0	0	0	0	0	0	0	0	0	0	0	0	1	1	1	1	1	0
Blue(63)	0	0	0	0	0	0	0	0	0	0	0	0	1	1	1	1	1	1	

Note (1) 0: Low Level Voltage, 1: High Level Voltage

#### 5.4 EDID DATA STRUCTURE

The EDID (Extended Display Identification Data) data formats are to support displays as defined in the VESA Plug & Display and FPD standards.

Byte # (decimal)	Byte # (hex)	Field Name and Comments	Value (hex)	Value (binary)
0	0	Header	00	00000000
1	1	Header	FF	11111111
2	2	Header	FF	11111111
3	3	Header	FF	11111111
4	4	Header	FF	11111111
5	5	Header	FF	11111111
6	6	Header	FF	11111111
7	7	Header	00	00000000
8	8	EISA ID manufacturer name ("CMO")	0D	00001101
9	9	EISA ID manufacturer name (Compressed ASCII)	AF	10101111
10	0A	ID product code (N101L6-L0C)	17	00010111
11	0B	ID product code (hex LSB first; N101L6-L0C)	10	00010000
12	0C	ID S/N (fixed "0")	00	00000000
13	0D	ID S/N (fixed "0")	00	00000000
14	0E	ID S/N (fixed "0")	00	00000000
15	0F	ID S/N (fixed "0")	00	00000000
16	10	Week of manufacture (fixed week code)	33	00110011
17	11	Year of manufacture (fixed year code)	13	00010011
18	12	EDID structure version # ("1")	01	00000001
19	13	EDID revision # ("3")	03	00000011
20	14	Video I/P definition ("digital")	80	10000000
21	15	Max H image size ("22.272cm")	16	00010110
22	16	Max V image size ("12.53cm")	0C	00001100
23	17	Display Gamma (Gamma = "2.2")	78	01111000
24	18	Feature support ("Active off, RGB Color")	0A	00001010
25	19	Rx1, Rx0, Ry1, Ry0, Gx1, Gx0, Gy1, Gy0	4B	01001011
26	1A	Bx1, Bx0, By1, By0, Wx1, Wx0, Wy1, Wy0	E5	11100101
27	1B	Rx=0.56	8F	10001111
28	1C	Ry=0.355	5B	01011011
29	1D	Gx=0.35	59	01011001
30	1E	Gy=0.565	90	10010000
31	1F	Bx=0.155	27	00100111
32	20	By=0.115	1D	00011101
33	21	Wx=0.313	50	01010000
34	22	Wy=0.329	54	01010100
35	23	Established timings 1	00	00000000
36	24	Established timings 2	00	00000000
37	25	Manufacturer's reserved timings	00	00000000
38	26	Standard timing ID # 1	01	00000001
39	27	Standard timing ID # 1	01	00000001
40	28	Standard timing ID # 2	01	00000001
41	29	Standard timing ID # 2	01	00000001

Byte # (decimal)	Byte # (hex)	Field Name and Comments	Value (hex)	Value (binary)
42	2A	Standard timing ID # 3	01	00000001
43	2B	Standard timing ID # 3	01	00000001
44	2C	Standard timing ID # 4	01	00000001
45	2D	Standard timing ID # 4	01	00000001
46	2E	Standard timing ID # 5	01	00000001
47	2F	Standard timing ID # 5	01	00000001
48	30	Standard timing ID # 6	01	00000001
49	31	Standard timing ID # 6	01	00000001
50	32	Standard timing ID # 7	01	00000001
51	33	Standard timing ID # 7	01	00000001
52	34	Standard timing ID # 8	01	00000001
53	35	Standard timing ID # 8	01	00000001
54	36	Detailed timing description # 1 Pixel clock ("43.97MHz", According to VESA CVT Rev1.1)	2D	00101101
55	37	# 1 Pixel clock (hex LSB first)	11	00010001
56	38	# 1 H active ("1024")	00	00000000
57	39	# 1 H blank ("160")	A0	10100000
58	3A	# 1 H active : H blank ("1024 : 160")	40	01000000
59	3B	# 1 V active ("600")	58	01011000
60	3C	# 1 V blank ("19")	13	00010011
61	3D	# 1 V active : V blank ("600 : 19")	20	00100000
62	3E	# 1 H sync offset ("48")	30	00110000
63	3F	# 1 H sync pulse width ("32")	20	00100000
64	40	# 1 V sync offset : V sync pulse width ("3 : 10")	3A	00111010
65	41	# 1 H sync offset : H sync pulse width : V sync offset : V sync width ("48: 32 : 3 : 10")	00	00000000
66	42	# 1 H image size ("222 mm")	DE	11011110
67	43	# 1 V image size ("125 mm")	7D	01111101
68	44	# 1 H image size : V image size ("222 : 125")	00	00000000
69	45	# 1 H boarder ("0")	00	00000000
70	46	# 1 V boarder ("0")	00	00000000
71	47	# 1 Non-interlaced, Normal, no stereo, Separate sync, H/V pol Negatives	18	00011000
72	48	Detailed timing description # 2	00	00000000
73	49	# 2 Flag	00	00000000
74	4A	# 2 Reserved	00	00000000
75	4B	# 2 FE (hex) defines ASCII string (Model Name "N101L6-L0C", ASCII)	FE	11111110
76	4C	# 2 Flag	00	00000000
77	4D	# 2 1st character of name ("N")	4E	01001110
78	4E	# 2 2nd character of name ("1")	31	00110001
79	4F	# 2 3rd character of name ("0")	30	00110000
80	50	# 2 4th character of name ("1")	31	00110001
81	51	# 2 5th character of name ("L")	4C	01001100
82	52	# 2 6th character of name ("6")	36	00110110
83	53	# 2 7th character of name (".")	2D	00101101
84	54	# 2 8th character of name ("L")	4C	01001100

Byte # (decimal)	Byte # (hex)	Field Name and Comments	Value (hex)	Value (binary)
85	55	# 2 9th character of name ("0")	30	00110000
86	56	# 2 9th character of name ("C")	43	01000011
87	57	# 2 New line character indicates end of ASCII string	0A	00001010
88	58	# 2 Padding with "Blank" character	20	00100000
89	59	# 2 Padding with "Blank" character	20	00100000
90	5A	Detailed timing description # 3	00	00000000
91	5B	# 3 Flag	00	00000000
92	5C	# 3 Reserved	00	00000000
93	5D	# 3 FE (hex) defines ASCII string (Vendor "CMO", ASCII)	FE	11111110
94	5E	# 3 Flag	00	00000000
95	5F	# 3 1st character of string ("C")	43	01000011
96	60	# 3 2nd character of string ("M")	4D	01001101
97	61	# 3 3rd character of string ("O")	4F	01001111
98	62	# 3 New line character indicates end of ASCII string	0A	00001010
99	63	# 3 Padding with "Blank" character	20	00100000
100	64	# 3 Padding with "Blank" character	20	00100000
101	65	# 3 Padding with "Blank" character	20	00100000
102	66	# 3 Padding with "Blank" character	20	00100000
103	67	# 3 Padding with "Blank" character	20	00100000
104	68	# 3 Padding with "Blank" character	20	00100000
105	69	# 3 Padding with "Blank" character	20	00100000
106	6A	# 3 Padding with "Blank" character	20	00100000
107	6B	# 3 Padding with "Blank" character	20	00100000
108	6C	Detailed timing description # 4	00	00000000
109	6D	# 4 Flag	00	00000000
110	6E	# 4 Reserved	00	00000000
111	6F	# 4 FE (hex) defines ASCII string (Model Name"N101L6-L0C", ASCII)	FE	11111110
112	70	# 4 Flag	00	00000000
113	71	# 4 1st character of name ("N")	4E	01001110
114	72	# 4 2nd character of name ("1")	31	00110001
115	73	# 4 3rd character of name ("0")	30	00110000
116	74	# 4 4th character of name ("1")	31	00110001
117	75	# 4 5th character of name ("L")	4C	01001100
118	76	# 4 6th character of name ("6")	36	00110110
119	77	# 4 7th character of name ("-")	2D	00101101
120	78	# 4 8th character of name ("L")	4C	01001100
121	79	# 4 9th character of name ("0")	30	00110000
122	7A	# 4 9th character of name ("C")	43	01000011
123	7B	# 4 New line character indicates end of ASCII string	0A	00001010
124	7C	# 4 Padding with "Blank" character	20	00100000
125	7D	# 4 Padding with "Blank" character	20	00100000
126	7E	Extension flag	00	00000000
127	7F	Checksum	E1	11100001



## 6. CONVERTER SPECIFICATION

### 6.1 ABSOLUTE MAXIMUM RATINGS

Symbol	Ratings
LED_VCCS	-0.3~25V
LED_PWM	-0.3V~5.5
LED_EN	-0.3V~5.5V

### 6.2 RECOMMENDED OPERATING RATINGS

Parameter	Symbol	Value			Unit	Note	
		Min.	Typ.	Max.			
Converter Input power supply voltage	LED_VCCS	5.0	12.0	21.0	V	-	
Converter Rush Current	$I_{LED_{RUSH}}$	-	-	1.5	A	(1)	
Converter Initial Stage Current	$I_{LED_{IS}}$	-	-	1.5	A	(1)	
Enable Control Level	Backlight On	LED_EN	2.3	-	5.5	V	-
	Backlight Off	LED_EN	0	-	0.5	V	-
PWM Control Level	PWM High Level	LED_PWM	2.3	-	5.5	V	-
	PWM Low Level	LED_PWM	0	-	0.5	V	-
PWM Control Duty Ratio			10	-	100	%	-
			5	-	100	%	(2)
PWM Control Permissible Ripple Voltage	$V_{PWM_{pp}}$	-	-	100	mV	-	
PWM Control Frequency	$f_{PWM}$	190	-	2K	Hz	(3)	
Converter Input Current	$V_{in} = \text{Min.}$	$I_{LED}$	294	361	428	mA	(4)
	$V_{in} = \text{Typ.}$		122	151	179	mA	(4)
	$V_{in} = \text{Max.}$		70	86	102	mA	(4)

Note (1)  $I_{LED_{RUSH}}$ : the maximum current when LED\_VCCS is rising,

$I_{LED_{IS}}$ : the maximum current of the first 100ms after power-on,

Measurement Conditions: Shown as the following figure. LED\_VCCS = Typ,  $T_a = 25 \pm 2 \text{ }^\circ\text{C}$ ,  $f_{PWM} = 200 \text{ Hz}$ , Duty=100%.

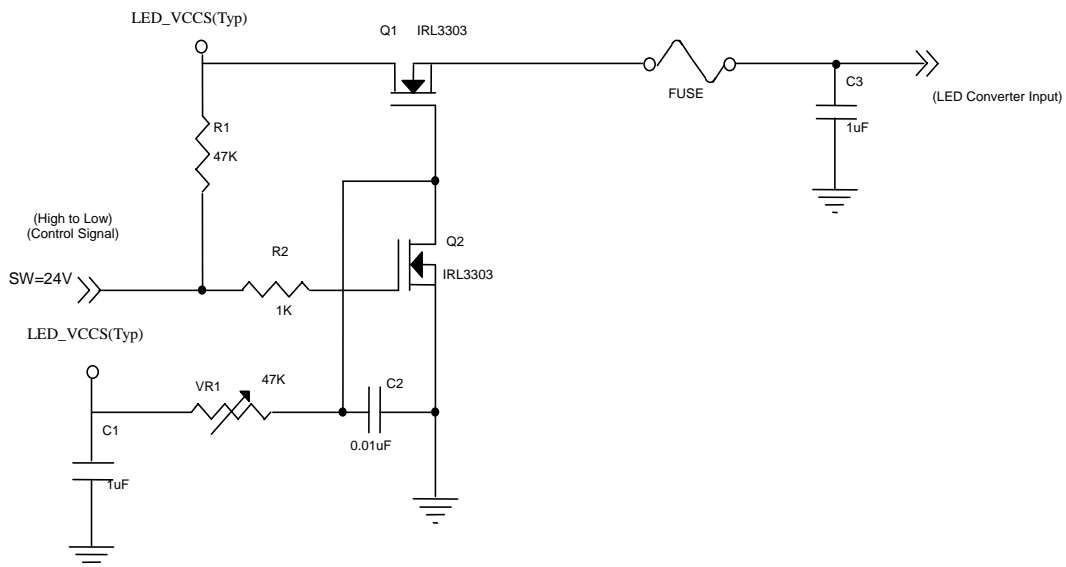

**VLED rising time is 0.5ms**

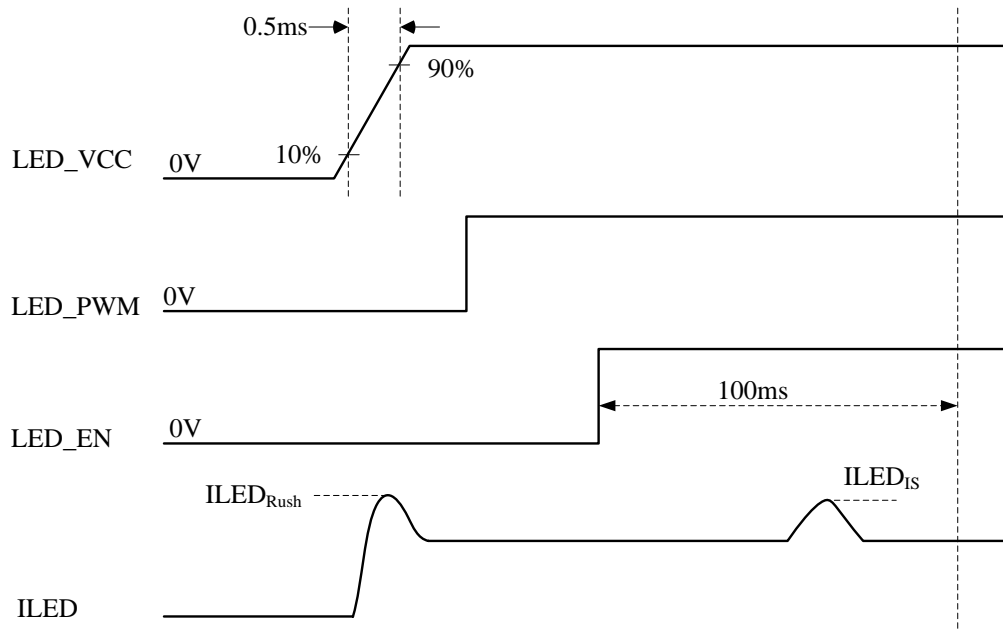

Note (2) If the PWM control duty ratio is less than 10%, there is some possibility that acoustic noise or backlight flash can be found. And it is also difficult to control the brightness linearity.

Note (3) If PWM control frequency is applied in the range less than 1KHz, the “waterfall” phenomenon on the screen may be found. To avoid the issue, it’s a suggestion that PWM control frequency should follow the criterion as below.

PWM control frequency  $f_{PWM}$  should be in the range

$$(N + 0.33) * f \leq f_{PWM} \leq (N + 0.66) * f$$

$N$  : Integer ( $N \geq 3$ )

$f$  : Frame rate

Note (4) The specified LED power supply current is under the conditions at “LED\_VCCS = Min., Typ., Max.”,  $T_a = 25 \pm 2 \text{ }^\circ\text{C}$ ,  $f_{PWM} = 200 \text{ Hz}$ , Duty=100%.

## 7. INTERFACE TIMING

### 7.1 INPUT SIGNAL TIMING SPECIFICATIONS

The input signal timing specifications are shown as the following table and timing diagram.

Signal	Item	Symbol	Min.	Typ.	Max.	Unit	Note
DCLK	Frequency	1/Tc	39.57	43.97	46.16	MHz	-
DE	Vertical Total Time	TV	604	619	624	TH	-
	Vertical Active Display Period	TVD	600	600	600	TH	-
	Vertical Active Blanking Period	TVB	TV-TVD	19	TV-TVD	TH	-
	Horizontal Total Time	TH	1106	1184	1224	Tc	-
	Horizontal Active Display Period	THD	1024	1024	1024	Tc	-
	Horizontal Active Blanking Period	THB	TH-THD	160	TH-THD	Tc	-

Note (1) Because this module is operated by DE only mode, Hsync and Vsync are ignored.

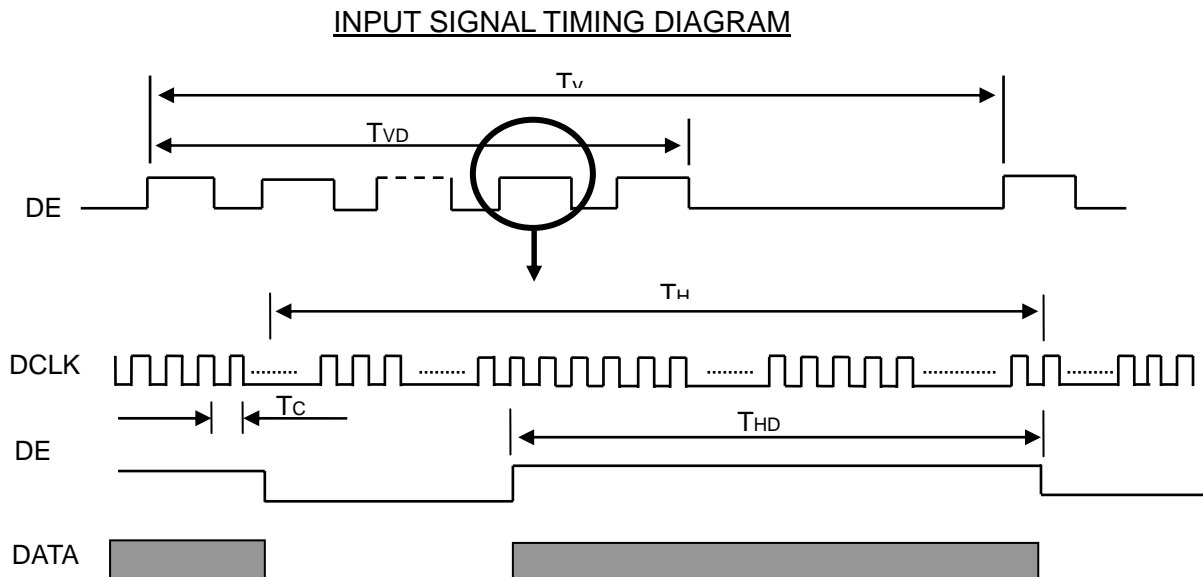

## 7.2 POWER ON/OFF SEQUENCE

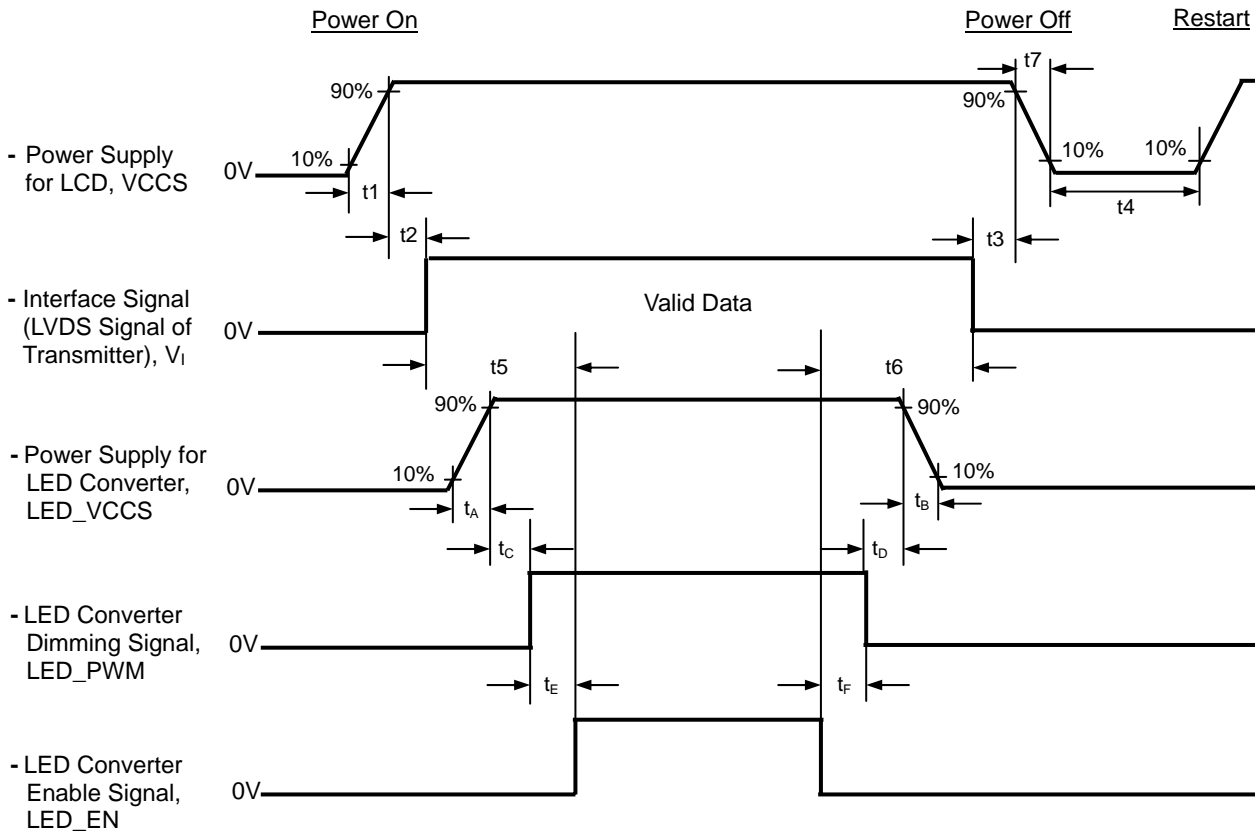

### Timing Specifications:

0.5	t1	10 ms
0	t2	50 ms
0	t3	50 ms
	t4	500 ms
	t5	200 ms
	t6	200 ms
0.5	t7	10 ms
0.5	tA	10 ms
0 <	tB	10 ms
	tC	10 ms
	tD	10 ms
	tE	10 ms
	tF	10 ms

Note (1) Please follow the power on/off sequence described above. Otherwise, the LCD module might be damaged.

Note (2) Please avoid floating state of interface signal at invalid period. When the interface signal is invalid, be sure to pull down the power supply of LCD VCCS to 0 V.

Note (3) The backlight must be turned on after the power supply for the logic and the interface signal is valid. The backlight must be turned off before the power supply for the logic and the interface signal is invalid

Note (4) Please follow the LED converter power sequence as above. If the customer could not follow, it might cause backlight flash issue during display ON/OFF or damage the LED backlight controller

## 8. OPTICAL CHARACTERISTICS

### 8.1 TEST CONDITIONS

Item	Symbol	Value	Unit
Ambient Temperature	T <sub>a</sub>	25±2	°C
Ambient Humidity	H <sub>a</sub>	50±10	%RH
Supply Voltage	V <sub>CC</sub>	3.3	V
Input Signal	According to typical value in "3. ELECTRICAL CHARACTERISTICS"		
LED Light Bar Input Current	I <sub>L</sub>	60	mA

The measurement methods of optical characteristics are shown in Section 8.2. The following items should be measured under the test conditions described in Section 8.1 and stable environment shown in Note (5).

### 8.2 OPTICAL SPECIFICATIONS

The relative measurement methods of optical characteristics are shown in 8.2. The following items should be measured under the test conditions described in 8.1 and stable environment shown in Note (5).

Item		Symbol	Condition	Min.	Typ.	Max.	Unit	Note	
Contrast Ratio		CR	$\theta_x=0^\circ, \theta_y=0^\circ$ Viewing Normal Angle	400	500	-	-	(2),(5), (7)	
Response Time		T <sub>R</sub>		-	3	8	ms	(3), (7)	
		T <sub>F</sub>		-	7	12	ms		
Average Luminance of White		L <sub>Ave</sub>			160	200	-	cd/m <sup>2</sup>	(4), (5), (7)
Color Chromaticity	Red	R <sub>x</sub>		Viewing Normal Angle	TYP. -0.03	0.560	TYP. +0.03	-	(1), (7)
		R <sub>y</sub>				0.355		-	
	Green	G <sub>x</sub>				0.350		-	
		G <sub>y</sub>				0.565		-	
	Blue	B <sub>x</sub>				0.155		-	
		B <sub>y</sub>				0.115		-	
	White	W <sub>x</sub>	0.313			-			
		W <sub>y</sub>	0.329			-			
Viewing Angle	Horizontal	$\theta_{x+}$	CR≥10	40	45	-	Deg.	(1),(5), (7)	
		$\theta_{x-}$		40	45	-			
	Vertical	$\theta_{y+}$		15	20	-			
		$\theta_{y-}$		40	45	-			
White Variation of 5 Points		$\delta W_{5p}$	$\theta_x=0^\circ, \theta_y=0^\circ$	80	-	-	%	(5),(6), (7)	

Note (1) Definition of Viewing Angle ( $\theta_x$ ,  $\theta_y$ ):

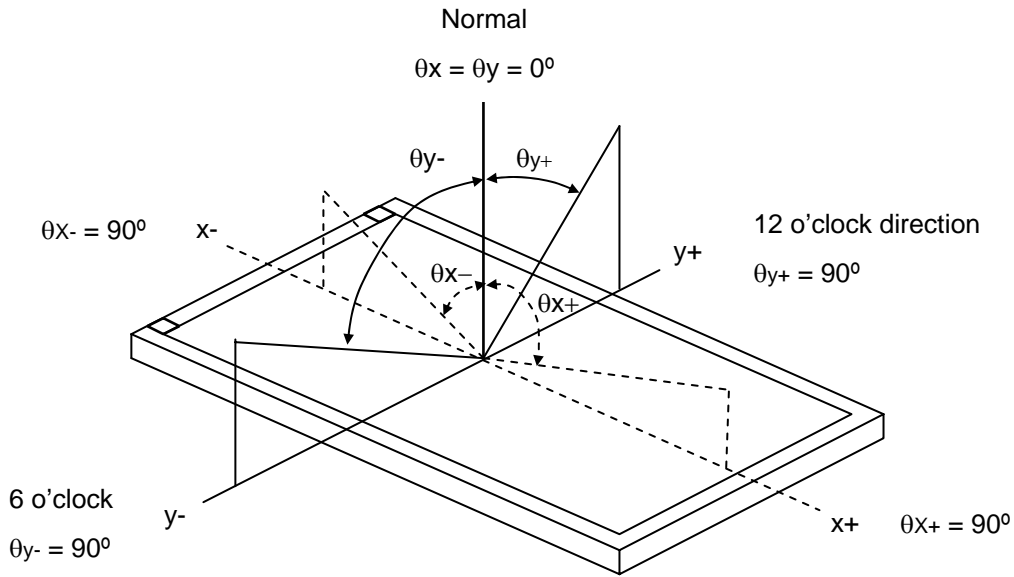

Note (2) Definition of Contrast Ratio (CR):

The contrast ratio can be calculated by the following expression.

$$\text{Contrast Ratio (CR)} = L_{63} / L_0$$

L63: Luminance of gray level 63

L 0: Luminance of gray level 0

$$CR = CR (1)$$

CR (X) is corresponding to the Contrast Ratio of the point X at Figure in Note (6).

Note (3) Definition of Response Time ( $T_R$ ,  $T_F$ ):

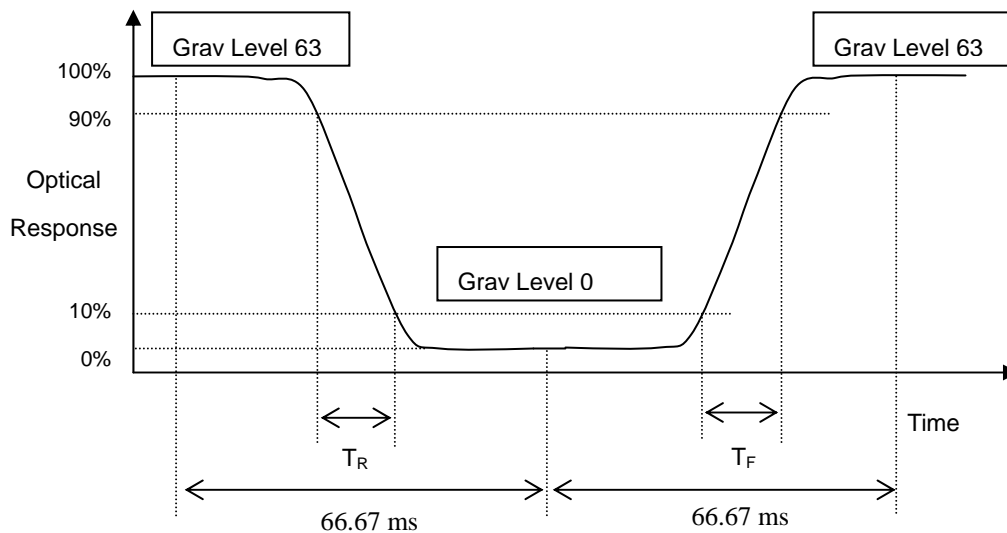

Note (4) Definition of Average Luminance of White ( $L_{AVE}$ ):

Measure the luminance of gray level 63 at 5 points

$$L_{AVE} = [L(1) + L(2) + L(3) + L(4) + L(5)] / 5$$

$L(x)$  is corresponding to the luminance of the point X at Figure in Note (6)

Note (5) Measurement Setup:

The LCD module should be stabilized at given temperature for 20 minutes to avoid abrupt temperature change during measuring. In order to stabilize the luminance, the measurement should be executed after lighting Backlight for 20 minutes in a windless room.

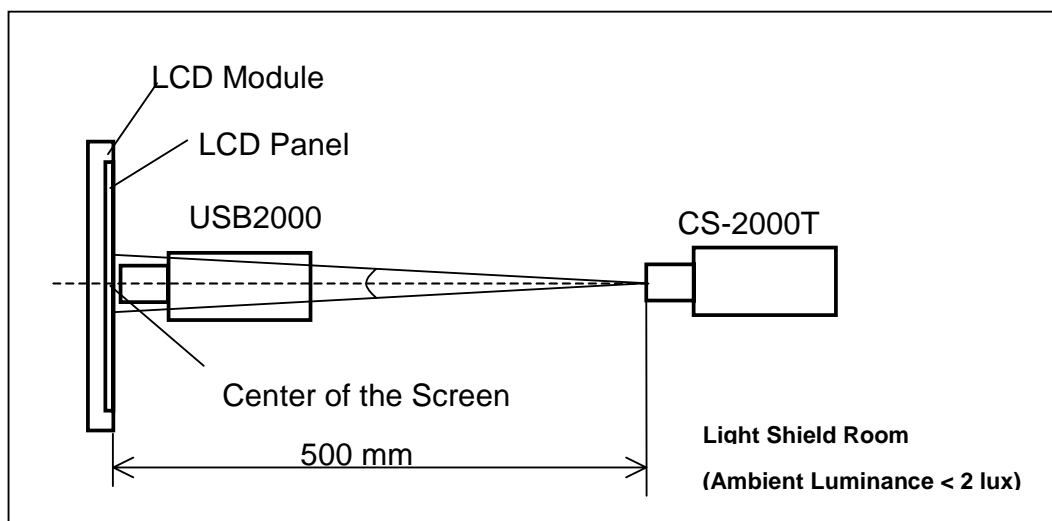

Note (6) Definition of White Variation ( $\delta W$ ):

Measure the luminance of gray level 63 at 5 points

$$\delta W = \{ \text{Minimum} [L(1), L(2), L(3), L(4), L(5)] / \text{Maximum} [L(1), L(2), L(3), L(4), L(5)] \}$$



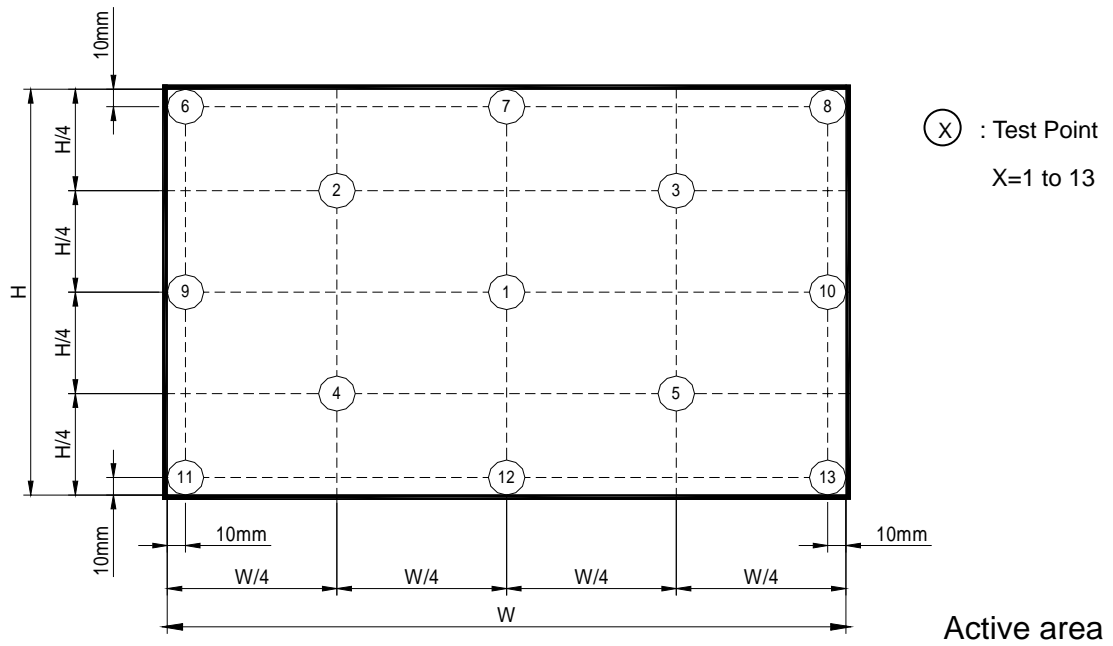

Note (7) The listed optical specifications refer to the initial value of manufacture, but the condition of the specifications after long-term operation will not be warranted.

## 9. PRECAUTIONS

### 9.1 SYSTEM MATCHING PRECAUTIONS

- (1) Refer to the drawing.
- (2) To avoid wireless noise interference, please keep the antenna away from LCD control board.

### 9.2 HANDLING PRECAUTIONS

- (1) The module should be assembled into the system firmly by using every mounting hole. Be careful not to twist or bend the module.
- (2) While assembling or installing modules, it can only be in the clean area. The dust and oil may cause electrical short or damage the polarizer.
- (3) Use fingerstalls or soft gloves in order to keep display clean during the incoming inspection and assembly process.
- (4) Do not press or scratch the surface harder than a HB pencil lead on the panel because the polarizer is very soft and easily scratched.
- (5) If the surface of the polarizer is dirty, please clean it by some absorbent cotton or soft cloth. Do not use Ketone type materials (ex. Acetone), Ethyl alcohol, Toluene, Ethyl acid or Methyl chloride. It might permanently damage the polarizer due to chemical reaction.
- (6) Wipe off water droplets or oil immediately. Staining and discoloration may occur if they left on panel for a long time.
- (7) If the liquid crystal material leaks from the panel, it should be kept away from the eyes or mouth. In case of contacting with hands, legs or clothes, it must be washed away thoroughly with soap.
- (8) Protect the module from static electricity, it may cause damage to the C-MOS Gate Array IC.
- (9) Do not disassemble the module.
- (10) Do not pull or fold the lamp wire.
- (11) Pins of I/F connector should not be touched directly with bare hands.

### 9.3 STORAGE PRECAUTIONS

- (1) High temperature or humidity may reduce the performance of module. Please store LCD module within the specified storage conditions.
- (2) It is dangerous that moisture come into or contacted the LCD module, because the moisture may damage LCD module when it is operating.
- (3) It may reduce the display quality if the ambient temperature is lower than 10 °C. For example, the response time will become slowly, and the starting voltage of lamp will be higher than the room temperature.

### 9.4 OPERATION PRECAUTIONS

- (1) Do not pull the I/F connector in or out while the module is operating.
- (2) Always follow the correct power on/off sequence when LCD module is connecting and operating. This can prevent the CMOS LSI chips from damage during latch-up.
- (3) The startup voltage of Backlight is approximately 1000 Volts. It may cause electrical shock while assembling with converter. Do not disassemble the module or insert anything into the Backlight unit.

### 9.5 OTHER PRECAUTIONS

- (1) When fixed patterns are displayed for a long time, remnant image is likely to occur.

## 10. PACKING

### 10.1 CARTON

Box Dimensions : 435(L)\*350(W)\*275(H)  
 Weight: Approx. 7.6kg(30 module .per. 1 box)

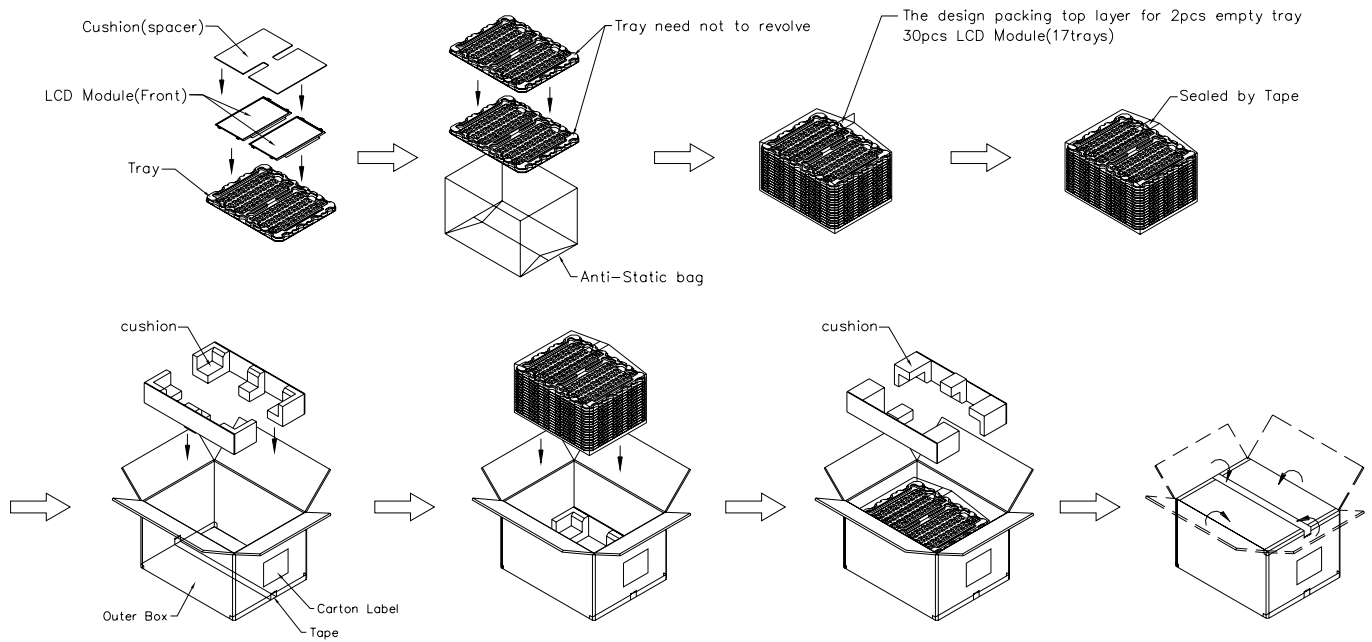
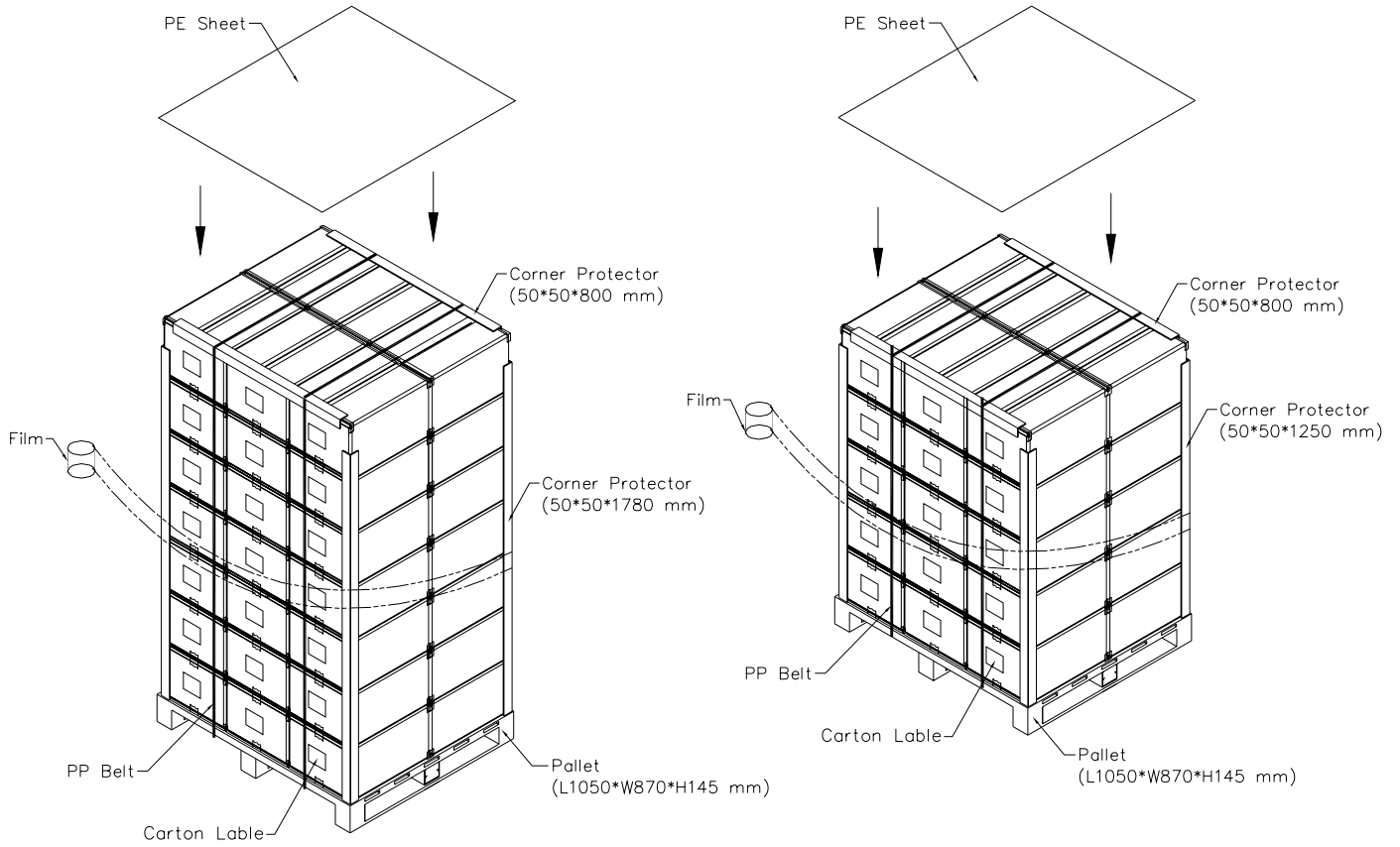

**Figure. 10-1 Packing method**

10.2 PALLET

Sea & Land Transportation

Air Transportation

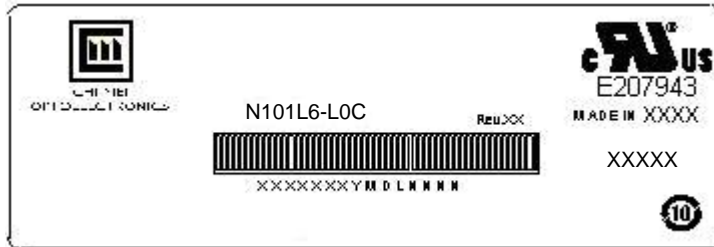

**Figure. 10-2 Packing method**

## 11. DEFINITION OF LABELS

### 11.1 CMO MODULE LABEL

The barcode nameplate is pasted on each module as illustration, and its definitions are as following explanation.



- (a) Model Name: N101L6 - L0C
- (b) Revision: Rev. XX, for example: A1, ..., C1, C2 ...etc.
- (c) Serial ID: X X X X X X X Y M D X N N N N

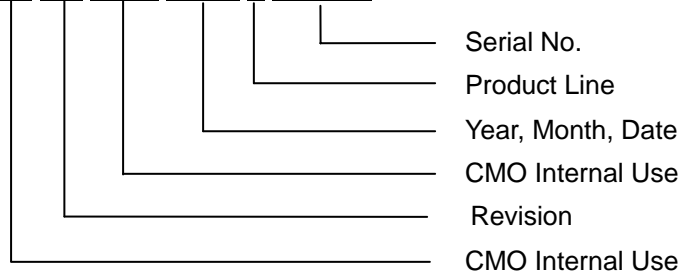

- (d) Production Location: MADE IN XXXX. XXXX stands for production location.
- (e) UL logo: "AAAA" especially stands for panel manufactured by CMO China satisfying UL requirement. "LEOO" and "COCKN" is the CMO's UL factory code for Ningbo factory..

Serial ID includes the information as below:

- (a) Manufactured Date: Year: 1~9, for 2001~2009  
 Month: 1~9, A~C, for Jan. ~ Dec.  
 Day: 1~9, A~Y, for 1<sup>st</sup> to 31<sup>st</sup>, exclude I , O and U
- (b) Revision Code: cover all the change
- (c) Serial No.: Manufacturing sequence of product
- (d) Product Line: 1 -> Line1, 2 -> Line 2, ...etc.

11.2 CMO CARTON LABEL

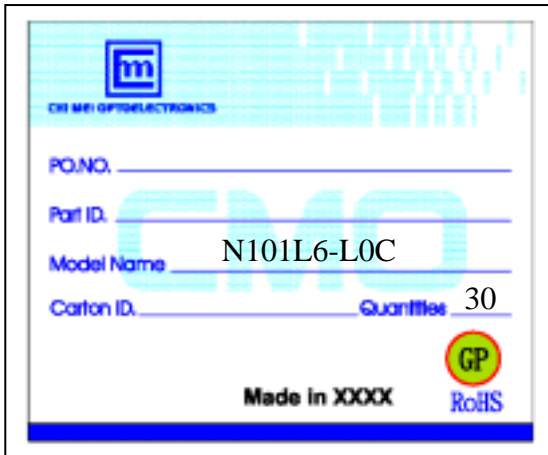

(a) Production location: Made In XXXX. XXXX stands for production location.

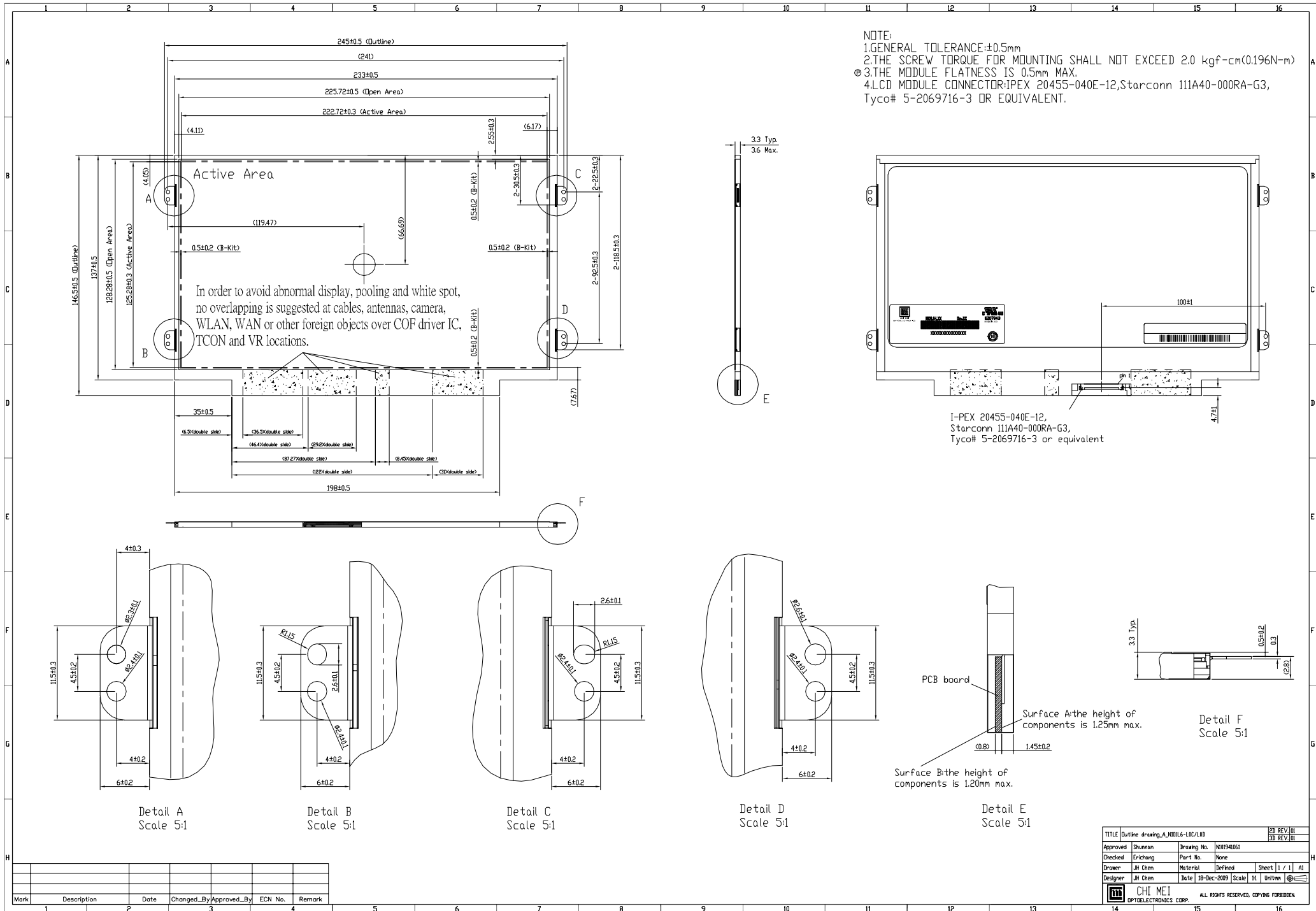

NOTE:  
 1.GENERAL TOLERANCE:±0.5mm  
 2.THE SCREW TORQUE FOR MOUNTING SHALL NOT EXCEED 2.0 kgf-cm(0.196N-m)  
 3.THE MODULE FLATNESS IS 0.5mm MAX.  
 4.LCD MODULE CONNECTOR:IPEX 20455-040E-12,Starconn 111A40-000RA-G3, Tyco# 5-2069716-3 OR EQUIVALENT.

In order to avoid abnormal display, pooling and white spot, no overlapping is suggested at cables, antennas, camera, WLAN, WAN or other foreign objects over COF driver IC, TCON and VR locations.

I-PEX 20455-040E-12,  
 Starconn 111A40-000RA-G3,  
 Tyco# 5-2069716-3 or equivalent

Detail A  
Scale 5:1

Detail B  
Scale 5:1

Detail C  
Scale 5:1

Detail D  
Scale 5:1

Detail E  
Scale 5:1

Detail F  
Scale 5:1

Mark	Description	Date	Changed_By	Approved_By	ECN No.	Remark

TITLE	Outline drawing_A_MOBILE-LCD/L00	23	REV/00
Approved	Shunnan	Drawing No.	N00941061
Checked	Erichang	Part No.	None
Drawer	JH Chen	Material	Defined
Designer	JH Chen	Date	18-Dec-2009
		Scale	1:1
		Sheet	1 / 1
		Unit	mm

CHI MEI OPTOELECTRONICS CORP. ALL RIGHTS RESERVED. COPYING FORBIDDEN.