

Doc. Number:

- Tentative Specification
 Preliminary Specification
 Approval Specification

MODEL NO.: N133BGE
SUFFIX: L31 65MJF

Customer: Dell
APPROVED BY
SIGNATURE
Name / Title

Note

Please return 1 copy for your confirmation with your signature and comments.

Approved By	Checked By	Prepared By
楊竣傑	陳逸銘	李佳蓉
2010-12-30 16:03:20 CST	2010-12-29 16:41:16 CST	2010-12-29 11:33:30 CST

CONTENTS

1. GENERAL DESCRIPTION	4
1.1 OVERVIEW.....	4
1.2 GENERAL SPECIFICATIONS	4
2. MECHANICAL SPECIFICATIONS	4
2.1 CONNECTOR TYPE	4
3. ABSOLUTE MAXIMUM RATINGS	5
3.1 ABSOLUTE RATINGS OF ENVIRONMENT.....	5
3.2 ELECTRICAL ABSOLUTE RATINGS.....	5
3.2.1 TFT LCD MODULE	5
4. ELECTRICAL SPECIFICATIONS.....	6
4.1 FUNCTION BLOCK DIAGRAM	6
4.2. INTERFACE CONNECTIONS.....	6
4.3 ELECTRICAL CHARACTERISTICS.....	8
4.3.1 LCD ELETRONICS SPECIFICATION.....	8
4.3.2 LED CONVERTER SPECIFICATION.....	10
4.3.3 BACKLIGHT UNIT.....	12
4.4 LVDS INPUT SIGNAL TIMING SPECIFICATIONS.....	12
4.4.1 LVDS DC SPECIFICATIONS	12
4.4.2 LVDS DATA FORMAT	13
4.4.3 COLOR DATA INPUT ASSIGNMENT	13
4.5 DISPLAY TIMING SPECIFICATIONS	15
4.6 POWER ON/OFF SEQUENCE.....	16
5. OPTICAL CHARACTERISTICS	17
5.1 TEST CONDITIONS	17
5.2 OPTICAL SPECIFICATIONS	17
6. RELIABILITY TEST ITEM	21
7. PACKING.....	22
7.1 MODULE LABEL	22
7.2 DELL Carton LABEL.....	23
7.3 CARTON.....	24
7.4 PALLET	25
8. PRECAUTIONS	26
8.1 HANDLING PRECAUTIONS.....	26
8.2 STORAGE PRECAUTIONS.....	26
8.3 OPERATION PRECAUTIONS.....	26
Appendix. EDID DATA STRUCTURE	27
Appendix. OUTLINE DRAWING	30

REVISION HISTORY

Version	Date	Page	Description
3.0	Sep.29,2010	All	Approval spec ver. 3.0 was first issued.
3.1	Dec.23,2010	5	Update 3.2.1 TFT LCD MODULE – (note).
		6	Update pin assignment for Macallan13 requests.
		8	Update LCD ELETRONICS specs for Macallan13 requests.
		17	Update optical specs for Macallan13 requests.
		22	Update label settings for Macallan13 requests.
		24	Update Packing method for Macallan13 requests.
		27	Update EDID code for Macallan13 requests.

1. GENERAL DESCRIPTION

1.1 OVERVIEW

N133BGE-L31 is a 13.3" (13.3" diagonal) TFT Liquid Crystal Display module with LED Backlight unit and 40 pins LVDS interface. This module supports 1366 x 768 HD mode and can display 262,144 colors. The optimum viewing angle is at 6 o'clock direction.

1.2 GENERAL SPECIFICATIONS

Item	Specification	Unit	Note
Screen Size	13.3 diagonal		
Driver Element	a-si TFT active matrix	-	-
Pixel Number	1366 x R.G.B. x 768	pixel	-
Pixel Pitch	0.2148 (H) x 0.2148 (V)	mm	-
Pixel Arrangement	RGB vertical stripe	-	-
Display Colors	262,144	color	-
Transmissive Mode	Normally white	-	-
Surface Treatment	Anti-Glare	-	-
Luminance, White	220	Cd/m2	
Power Consumption	Total 2.8 W (Max.) @ cell 0.6 W (Max.), BL 2.2 W (Max.)		(1)

Note (1) The specified power consumption is under the conditions at VCCS = 3.3 V, Ta = 25 ± 2 °C, LED_VCCS = Typ, fPWM = 200 Hz, Duty=100% and fv = 60 Hz, whereas mosaic pattern is displayed.

2. MECHANICAL SPECIFICATIONS

Item		Min.	Typ.	Max.	Unit	Note
Module Size	Horizontal (H)	313.6	314.1	314.6	mm	(1)
	Vertical (V)	188.25	188.75	189.25	mm	
	Thickness (T)	-	3.3	3.6	mm	
Bezel Area	Horizontal	296.316	296.816	297.316	mm	
	Vertical	167.866	168.366	168.866	mm	
Active Area	Horizontal	293.1168	293.4168	293.7168	mm	
	Vertical	164.6664	164.9664	165.2664	mm	
Weight		-	280	290	g	

Note (1) Please refer to the attached drawings for more information of front and back outline dimensions.

2.1 CONNECTOR TYPE

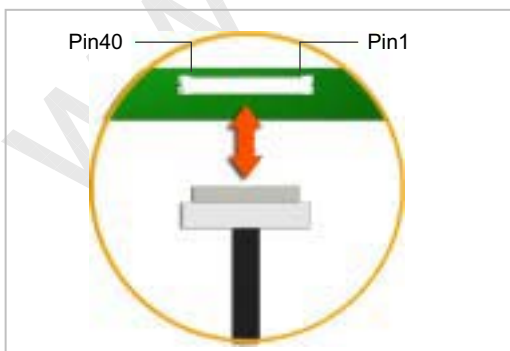

Please refer Appendix Outline Drawing for detail design.

Connector Part No.: IPEX-20455-040E-12 or equivalent

User's connector Part No: IPEX-20453-040T-01 or equivalent

3. ABSOLUTE MAXIMUM RATINGS

3.1 ABSOLUTE RATINGS OF ENVIRONMENT

Item	Symbol	Value		Unit	Note
		Min.	Max.		
Storage Temperature	T _{ST}	-20	+60	°C	(1)
Operating Ambient Temperature	T _{OP}	0	+50	°C	(1), (2)

Note (1) (a) 90 %RH Max. (T_a ≤ 40 °C).

(b) Wet-bulb temperature should be 39 °C Max. (T_a > 40 °C).

(c) No condensation.

Note (2) The temperature of panel surface should be 0 °C min. and 60 °C max.

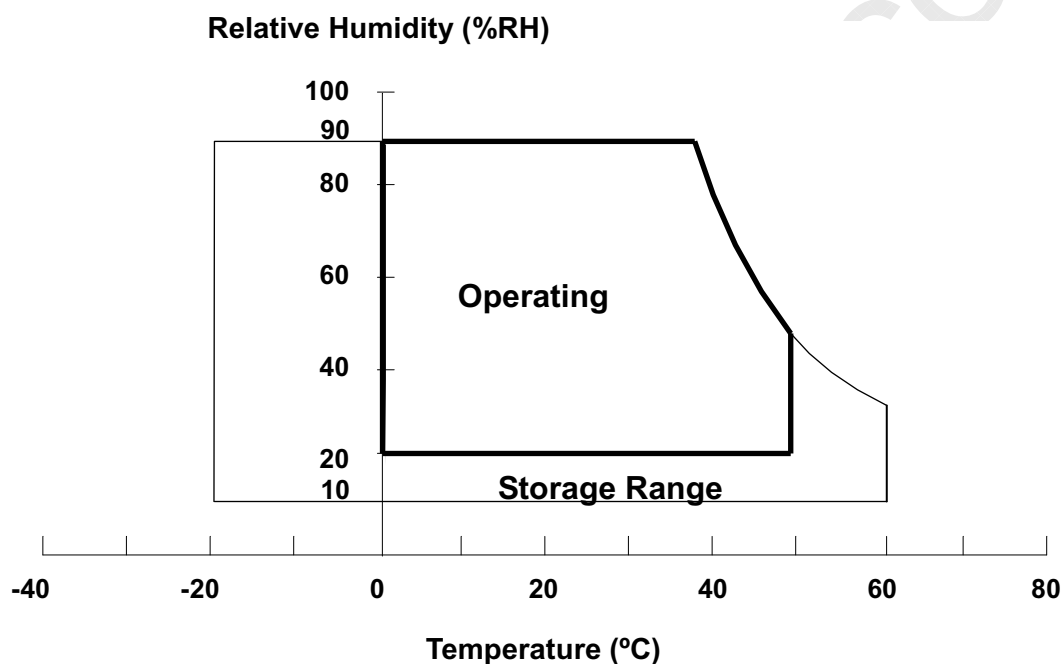

3.2 ELECTRICAL ABSOLUTE RATINGS

3.2.1 TFT LCD MODULE

Item	Symbol	Value		Unit	Note
		Min.	Max.		
Power Supply Voltage	V _{CCS}	-0.3	+4.0	V	(1)
Logic Input Voltage	V _{IN}	-0.3	V _{CCS} +0.3	V	
Converter Input Voltage	LED_V _{CCS}	-0.3	25	V	
Converter Control Signal Voltage	LED_PWM,	-0.3	6	V	
Converter Control Signal Voltage	LED_EN	-0.3	6	V	

Note (1) Stresses beyond those listed in above "ELECTRICAL ABSOLUTE RATINGS" may cause permanent damage to the device. Normal operation should be restricted to the conditions described in "ELECTRICAL CHARACTERISTICS".

4. ELECTRICAL SPECIFICATIONS

4.1 FUNCTION BLOCK DIAGRAM

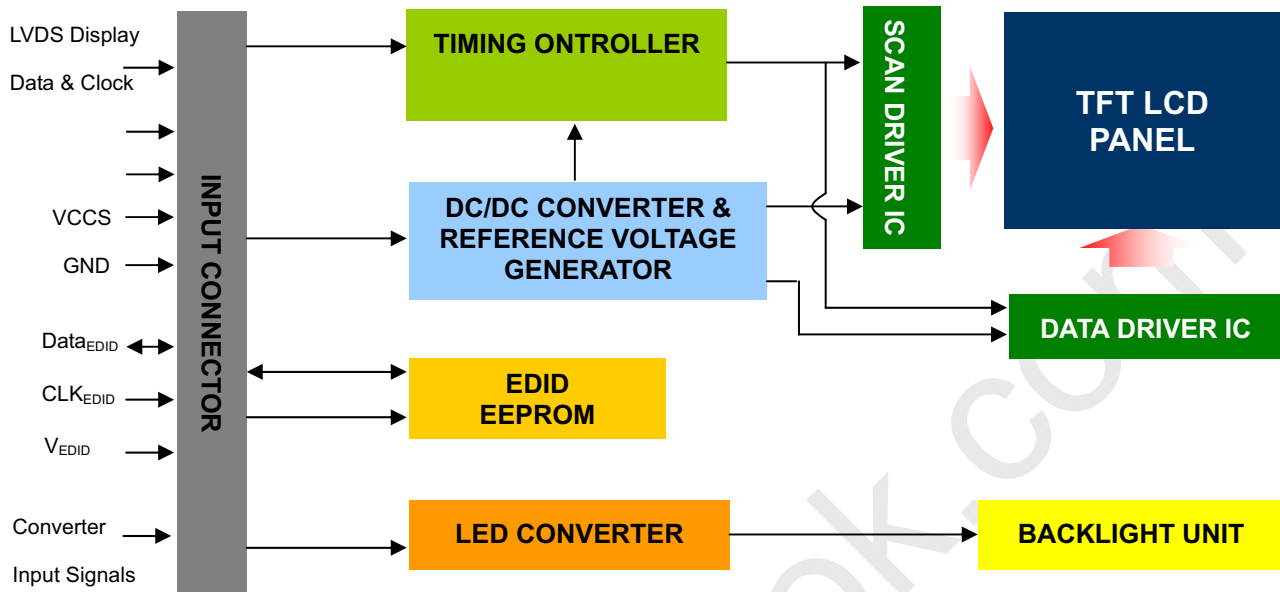

4.2. INTERFACE CONNECTIONS

PIN ASSIGNMENT

Pin	Symbol	Description	Remark
1	NC	Loop or No Connection	
2	VCCS	Power Supply (3.3V typ.)	
3	VCCS	Power Supply (3.3V typ.)	
4	VEDID	DDC 3.3V power	
5	BIST	Panel self test	
6	CLKEDID	DDC clock	
7	DATAEDID	DDC data	
8	Rxin0-	LVDS differential data input	R0-R5, G0
9	Rxin0+	LVDS differential data input	
10	VSS	Ground	
11	Rxin1-	LVDS differential data input	G1~G5, B0, B1
12	Rxin1+	LVDS differential data input	
13	VSS	Ground	
14	Rxin2-	LVDS Differential Data Input	B2-B5, HS, VS, DE
15	Rxin2+	LVDS Differential Data Input	
16	VSS	Ground	
17	RxCLK-	LVDS differential clock input	LVDS CLK
18	RxCLK+	LVDS differential clock input	
19	VSS	Ground	
20	NC	No Connection (Reserve)	
21	NC	No Connection (Reserve)	
22	VSS	Ground	
23	NC	No Connection (Reserve)	

24	NC	No Connection (Reserve)	
25	VSS	Ground	
26	NC	No Connection (Reserve)	
27	NC	No Connection (Reserve)	
28	VSS	Ground	
29	NC	No Connection (Reserve)	
30	NC	No Connection (Reserve)	
31	LED_GND	LED Ground	
32	LED_GND	LED Ground	
33	LED_GND	LED Ground	
34	NC	Loop or No Connection	
35	LED_PWM	PWM Control Signal of LED Converter	
36	LED_EN	Enable Control Signal of LED Converter	
37	CABC_EN	CABC Enable Input	
38	LED_VCCS	LED Power Supply	(Support 6 ~ 21V)
39	LED_VCCS	LED Power Supply	(Support 6 ~ 21V)
40	LED_VCCS	LED Power Supply	(Support 6 ~ 21V)

Note (1) The first pixel is odd as shown in the following figure.

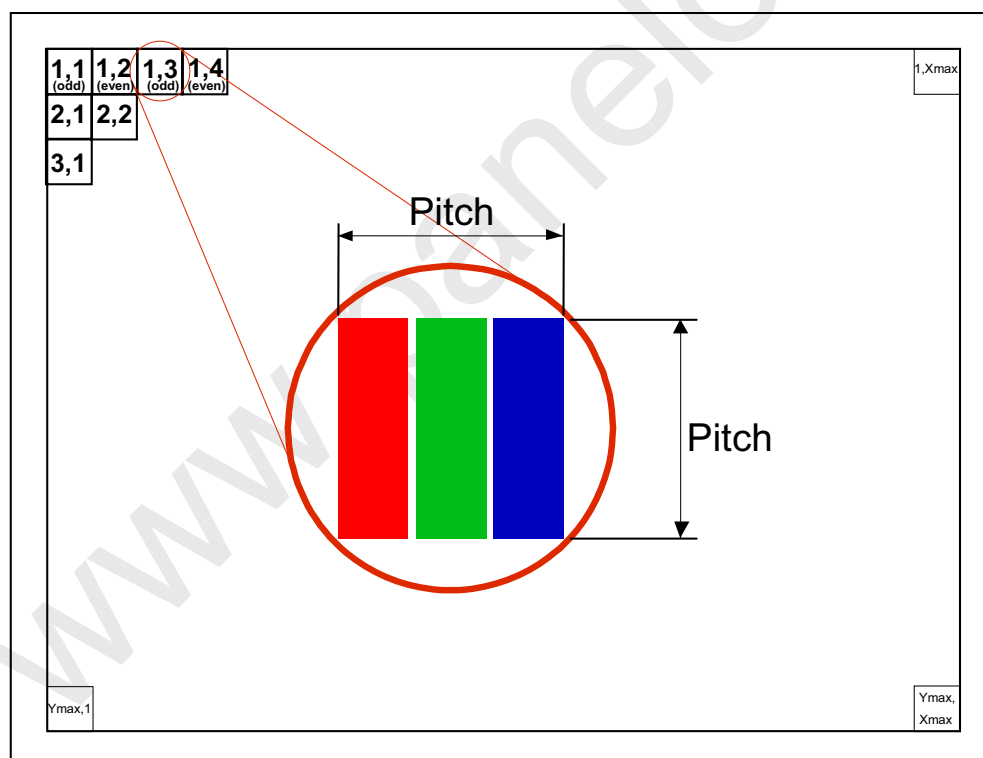

Note (2) The setting of Color engine and CABC function are as follows.

Pin	Enable	Disable
CABC_EN	Hi	Lo or Open

Hi = High level, Lo = Low level.

4.3 ELECTRICAL CHARACTERISTICS

4.3.1 LCD ELETRONICS SPECIFICATION

Parameter	Symbol	Value			Unit	Note	
		Min.	Typ.	Max.			
Power Supply Voltage	VCCS	3.0	3.3	3.6	V	-	
Ripple Voltage	V_{RP}	-	50	-	mV	-	
CABC_EN Input Voltage	High Level	V_{IHCE}	(2.3)	-	(3.6)	V	
	Low Level	V_{ILCE}	(0)	-	(0.5)	V	
Inrush Current	I_{RUSH}		-	1.5	A	(2)	
Power Supply Current	Mosaic	-	170	190	mA	(3)a	
	Black	-	200	230	mA	(3)b	

Note (1) The ambient temperature is $T_a = 25 \pm 2 \text{ }^\circ\text{C}$.

Note (2) I_{RUSH} : the maximum current when VCCS is rising

I_{IS} : the maximum current of the first 100ms after power-on

Measurement Conditions: Shown as the following figure. Test pattern: black.

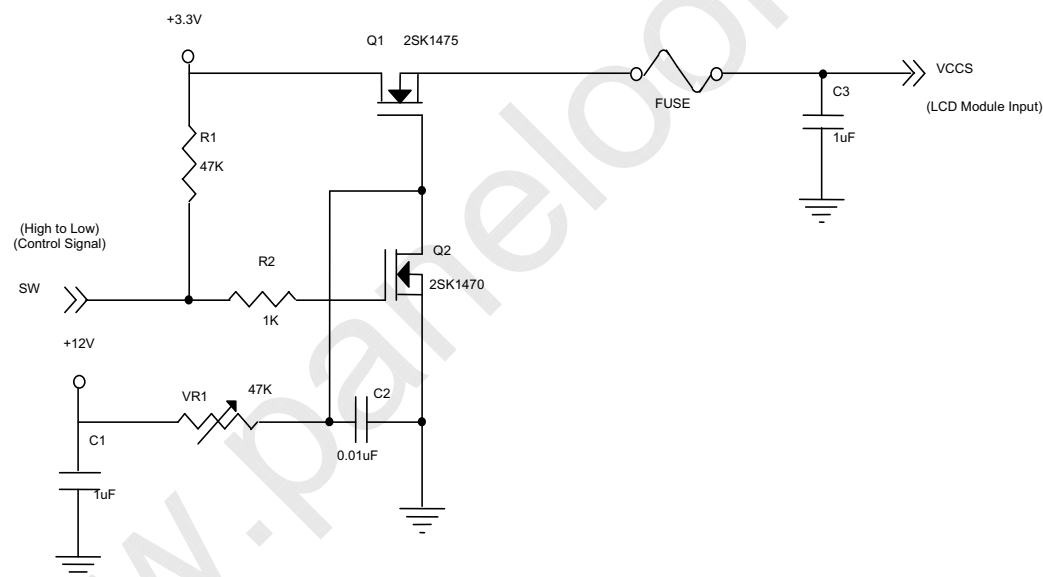

VCCS rising time is 0.5ms

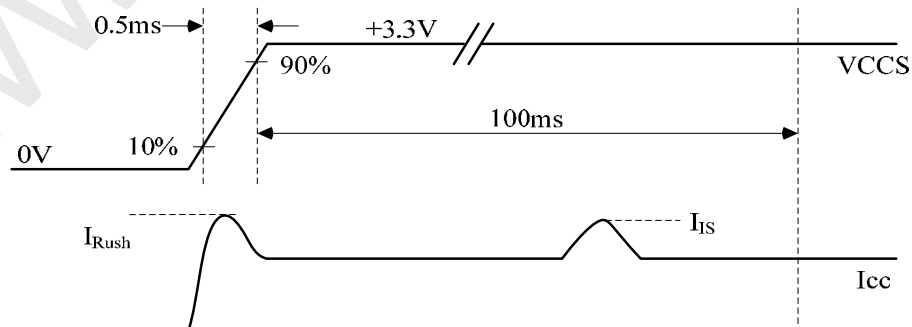

Note (3) The specified power supply current is under the conditions at $V_{CCS} = 3.3\text{ V}$, $T_a = 25 \pm 2\text{ }^\circ\text{C}$, DC Current and $f_v = 60\text{ Hz}$, whereas a power dissipation check pattern below is displayed.

a. Mosaic Pattern

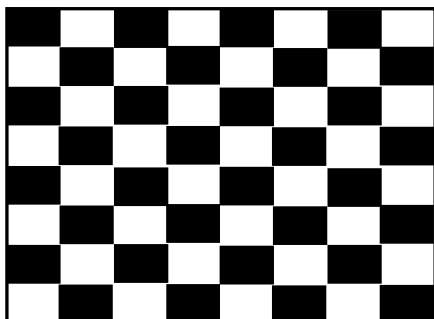

Active Area

b. Black Pattern

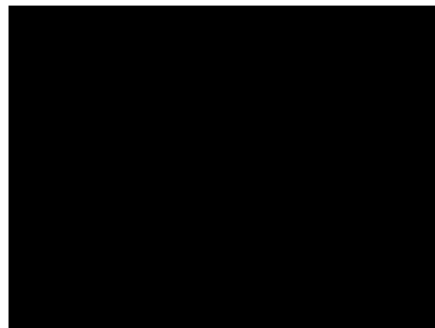

Active Area

www.panelook.com

4.3.2 LED CONVERTER SPECIFICATION

Parameter		Symbol	Value			Unit	Note
			Min.	Typ.	Max.		
Converter Input power supply voltage		LED_Vccs	6.0	12.0	21.0	V	
Converter Inrush Current		I _{LED_RUSH}	-	-	1.5	A	(1)
EN Control Level	Backlight On		2.3	-	5.5	V	
	Backlight Off		0	-	0.8	V	
PWM Control Level	PWM High Level		2.3	-	5.5	V	
	PWM Low Level		0	-	0.15	V	
PWM Control Duty Ratio			10	-	100	%	
			5	-	100	%	(2)
PWM Control Permissible Ripple Voltage		V _{PWM_pp}	-	-	100	mV	
PWM Control Frequency		f _{PWM}	190	-	2K	Hz	(3)
LED Power Current	LED_VCCS =Typ.	I _{LED}	133	164	201	mA	(4)

Note (1) I_{LED_RUSH}: the maximum current when LED_VCCS is rising,

I_{LED_IS}: the maximum current of the first 100ms after power-on,

Measurement Conditions: Shown as the following figure. LED_VCCS = Typ, Ta = 25 ± 2 °C, f_{PWM} = 200 Hz, Duty=100%.

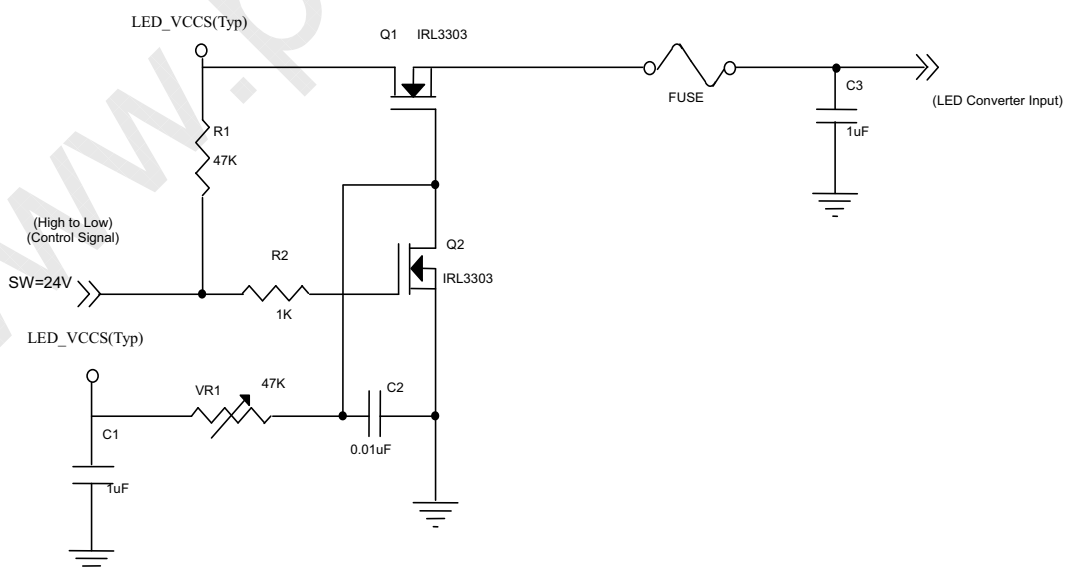

VLED rising time is 0.5ms

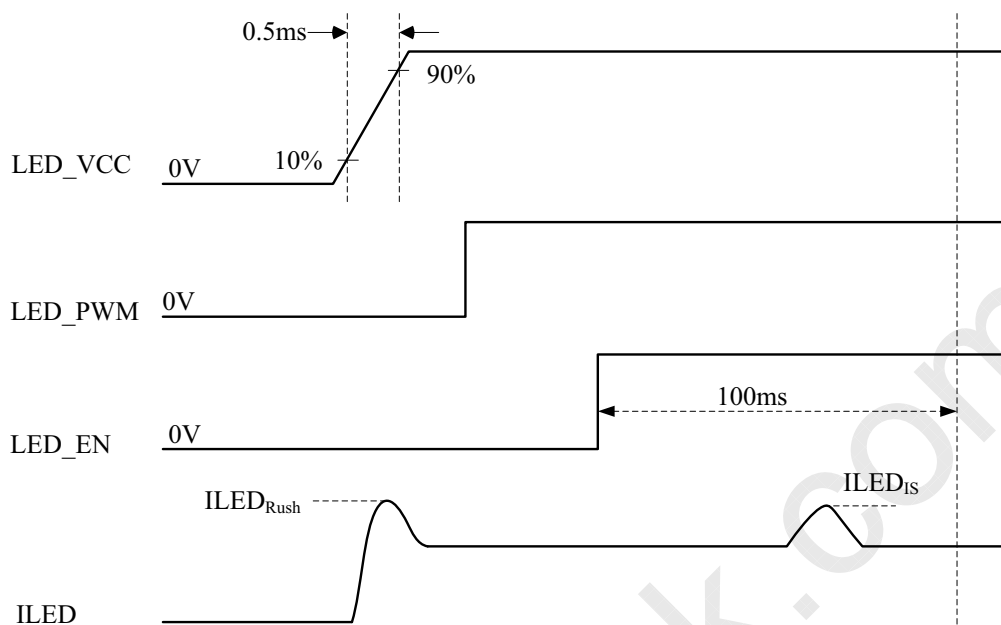

Note (2) If the PWM control duty ratio is less than 10%, there is some possibility that acoustic noise or backlight flash can be found. And it is also difficult to control the brightness linearity.

Note (3) If PWM control frequency is applied in the range less than 1KHz, the “waterfall” phenomenon on the screen may be found. To avoid the issue, it’s a suggestion that PWM control frequency should follow the criterion as below.

PWM control frequency f_{PWM} should be in the range

$$(N + 0.33) * f \leq f_{PWM} \leq (N + 0.66) * f$$

N : Integer ($N \geq 3$)

f : Frame rate

Note (4) The specified LED power supply current is under the conditions at “LED_VCCS = Typ.”, $T_a = 25 \pm 2$ °C, $f_{PWM} = 200$ Hz, Duty=100%.

4.3.3 BACKLIGHT UNIT

 $T_a = 25 \pm 2 \text{ }^\circ\text{C}$

Parameter	Symbol	Value			Unit	Note
		Min.	Typ.	Max.		
LED Light Bar Power Supply Voltage	V_L	28	31	34	V	(1)(2)(Duty100%)
LED Light Bar Power Supply Current	I_L	51.3	54	56.7	mA	
Power Consumption	P_L	1.436	1.674	1.928	W	(3)
LED Life Time	L_{BL}	12,000	-	-	Hrs	(4)

Note (1) LED current is measured by utilizing a high frequency current meter as shown below :

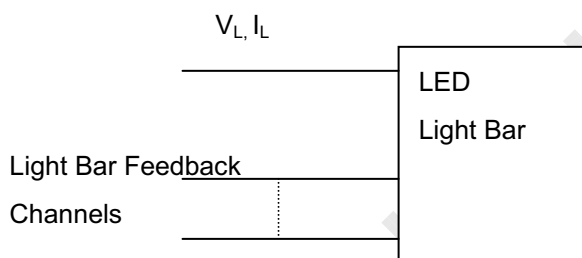

Note (2) For better LED light bar driving quality, it is recommended to utilize the adaptive boost converter with current balancing function to drive LED light-bar.

Note (3) $P_L = I_L \times V_L$ (Without LED converter transfer efficiency)

Note (4) The lifetime of LED is defined as the time when it continues to operate under the conditions at $T_a = 25 \pm 2 \text{ }^\circ\text{C}$ and $I_L = 18 \text{ mA(Per EA)}$ until the brightness becomes $\leq 50\%$ of its original value.

4.4 LVDS INPUT SIGNAL TIMING SPECIFICATIONS

4.4.1 LVDS DC SPECIFICATIONS

Parameter	Symbol	Value			Unit	Note
		Min.	Typ.	Max.		
LVDS Differential Input High Threshold	$V_{TH(LVDS)}$	-	-	+100	mV	(1), $V_{CM}=1.2V$
LVDS Differential Input Low Threshold	$V_{TL(LVDS)}$	-100	-	-	mV	(1), $V_{CM}=1.2V$
LVDS Common Mode Voltage	V_{CM}	1.125	-	1.375	V	(1)
LVDS Differential Input Voltage	$ V_{ID} $	100	-	600	mV	(1)
LVDS Terminating Resistor	R_T	-	100	-	Ohm	-

Note (1) The parameters of LVDS signals are defined as the following figures.

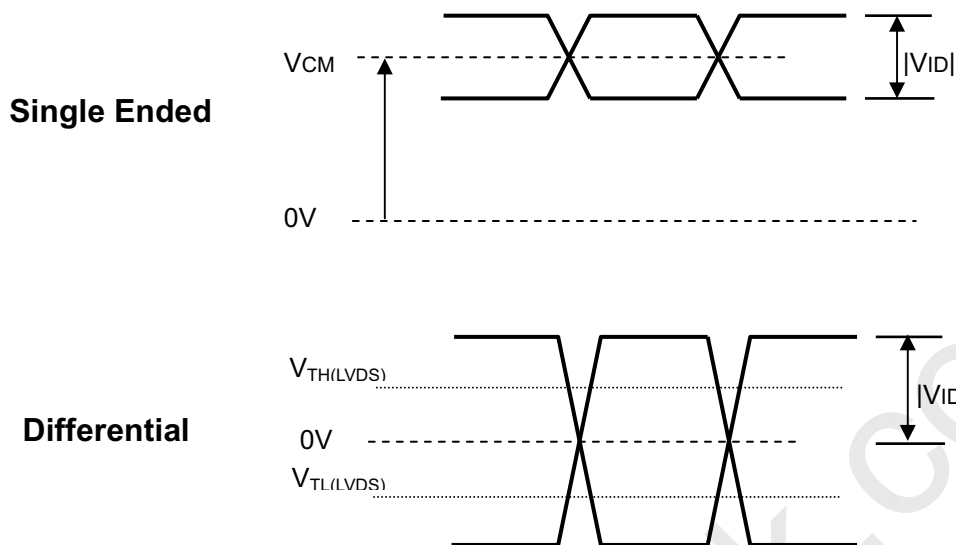

4.4.2 LVDS DATA FORMAT

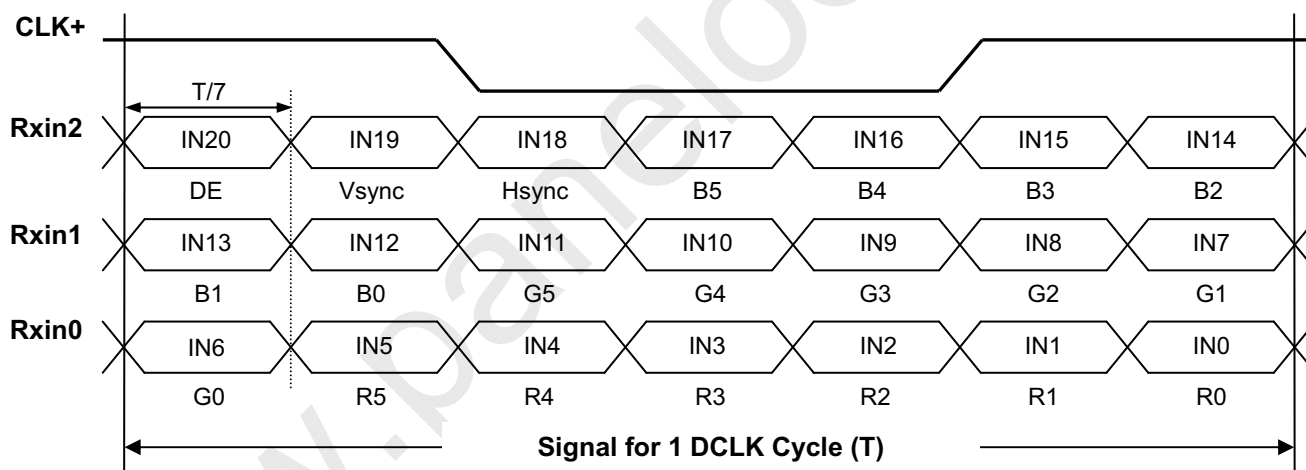

4.4.3 COLOR DATA INPUT ASSIGNMENT

The brightness of each primary color (red, green and blue) is based on the 6-bit gray scale data input for the color. The higher the binary input the brighter the color. The table below provides the assignment of color versus data input.

Color		Data Signal																	
		Red						Green						Blue					
		R5	R4	R3	R2	R1	R0	G5	G4	G3	G2	G1	G0	B5	B4	B3	B2	B1	B0
Basic Colors	Black	0	0	0	0	0	0	0	0	0	0	0	0	0	0	0	0	0	0
	Red	1	1	1	1	1	1	0	0	0	0	0	0	0	0	0	0	0	0
	Green	0	0	0	0	0	0	1	1	1	1	1	1	0	0	0	0	0	0
	Blue	0	0	0	0	0	0	0	0	0	0	0	0	1	1	1	1	1	1
	Cyan	0	0	0	0	0	0	1	1	1	1	1	1	1	1	1	1	1	1
	Magenta	1	1	1	1	1	1	0	0	0	0	0	0	1	1	1	1	1	1
	Yellow	1	1	1	1	1	1	1	1	1	1	1	1	0	0	0	0	0	0
	White	1	1	1	1	1	1	1	1	1	1	1	1	1	1	1	1	1	1

Gray Scale Of Red	Red(0)/Dark	0	0	0	0	0	0	0	0	0	0	0	0	0	0	0	0	0
	Red(1)	0	0	0	0	0	1	0	0	0	0	0	0	0	0	0	0	0
	Red(2)	0	0	0	0	1	0	0	0	0	0	0	0	0	0	0	0	0
	:	:	:	:	:	:	:	:	:	:	:	:	:	:	:	:	:	:
	:	:	:	:	:	:	:	:	:	:	:	:	:	:	:	:	:	:
	:	:	:	:	:	:	:	:	:	:	:	:	:	:	:	:	:	:
	Red(61)	1	1	1	1	0	1	0	0	0	0	0	0	0	0	0	0	0
	Red(62)	1	1	1	1	1	0	0	0	0	0	0	0	0	0	0	0	0
Red(63)	1	1	1	1	1	1	0	0	0	0	0	0	0	0	0	0	0	
Gray Scale Of Green	Green(0)/Dark	0	0	0	0	0	0	0	0	0	0	0	0	0	0	0	0	0
	Green(1)	0	0	0	0	0	0	0	0	0	0	1	0	0	0	0	0	0
	Green(2)	0	0	0	0	0	0	0	0	0	0	1	0	0	0	0	0	0
	:	:	:	:	:	:	:	:	:	:	:	:	:	:	:	:	:	:
	:	:	:	:	:	:	:	:	:	:	:	:	:	:	:	:	:	:
	:	:	:	:	:	:	:	:	:	:	:	:	:	:	:	:	:	:
	Green(61)	0	0	0	0	0	0	1	1	1	1	0	1	0	0	0	0	0
	Green(62)	0	0	0	0	0	0	1	1	1	1	1	0	0	0	0	0	0
Green(63)	0	0	0	0	0	0	1	1	1	1	1	1	0	0	0	0	0	
Gray Scale Of Blue	Blue(0)/Dark	0	0	0	0	0	0	0	0	0	0	0	0	0	0	0	0	0
	Blue(1)	0	0	0	0	0	0	0	0	0	0	0	0	0	0	0	0	1
	Blue(2)	0	0	0	0	0	0	0	0	0	0	0	0	0	0	0	1	0
	:	:	:	:	:	:	:	:	:	:	:	:	:	:	:	:	:	:
	:	:	:	:	:	:	:	:	:	:	:	:	:	:	:	:	:	:
	:	:	:	:	:	:	:	:	:	:	:	:	:	:	:	:	:	:
	Blue(61)	0	0	0	0	0	0	0	0	0	0	0	1	1	1	1	0	1
	Blue(62)	0	0	0	0	0	0	0	0	0	0	0	1	1	1	1	1	0
Blue(63)	0	0	0	0	0	0	0	0	0	0	0	1	1	1	1	1	1	

Note (1) 0: Low Level Voltage, 1: High Level Voltage

4.5 DISPLAY TIMING SPECIFICATIONS

The input signal timing specifications are shown as the following table and timing diagram.

Signal	Item	Symbol	Min.	Typ.	Max.	Unit	Note
DCLK	Frequency	1/Tc	50	75.44	80	MHz	-
DE	Vertical Total Time	TV	771	806	1008	TH	-
	Vertical Active Display Period	TVD	768	768	768	TH	-
	Vertical Active Blanking Period	TVB	TV-TVD	38	TV-TVD	TH	-
	Horizontal Total Time	TH	1448	1560	1950	Tc	-
	Horizontal Active Display Period	THD	1366	1366	1366	Tc	-
	Horizontal Active Blanking Period	THB	TH-THD	194	TH-THD	Tc	-

Note (1) Because this module is operated by DE only mode, Hsync and Vsync are ignored.

INPUT SIGNAL TIMING DIAGRAM

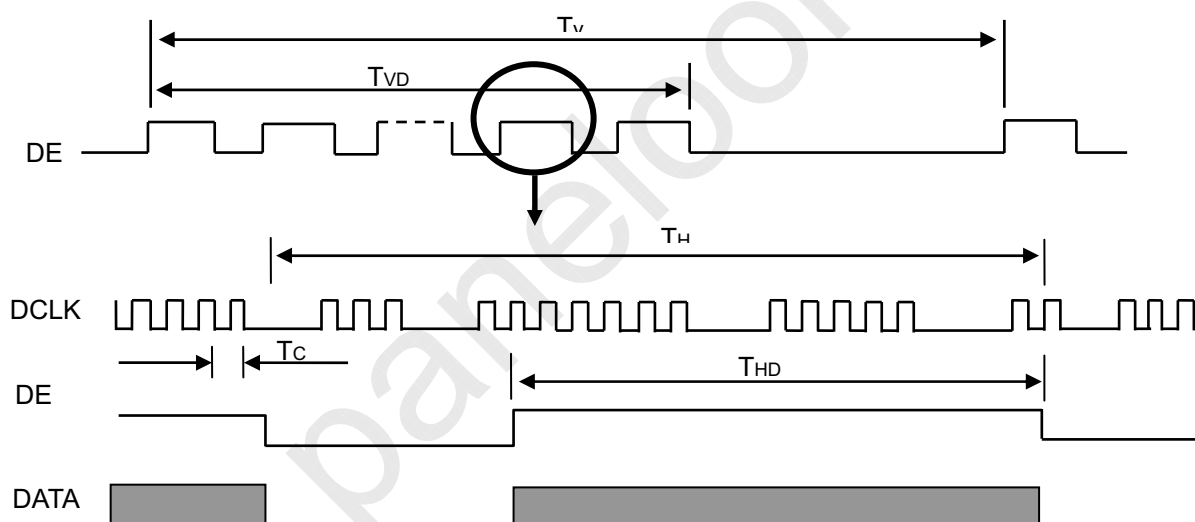

4.6 POWER ON/OFF SEQUENCE

The power sequence specifications are shown as the following table and diagram.

Symbol	Value			Unit	Note
	Min.	Typ.	Max.		
t1	0.5	-	10	ms	
t2	0	-	50	ms	
t3	0	-	50	ms	
t4	500	-	-	ms	
t5	200	-	-	ms	
t6	200	-	-	ms	
t7	0.5	-	10	ms	
t _A	0.5	-	10	ms	
t _B	0	-	10	ms	
t _C	10	-	-	ms	
t _D	10	-	-	ms	
t _E	10	-	-	ms	
t _F	10	-	-	ms	

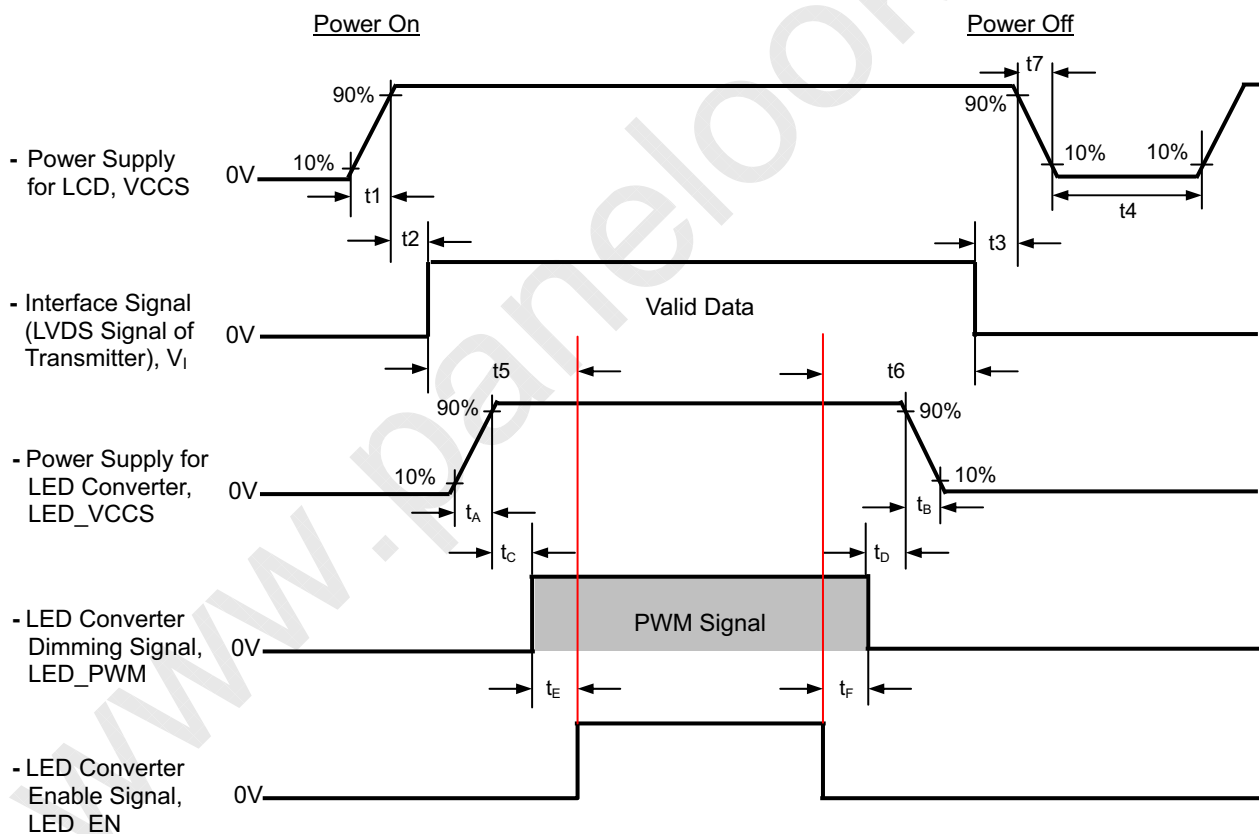

Note (1) Please don't plug the interface cable when system is turned on.

Note (2) Please avoid floating state of the interface signal during signal invalid period.

Note (3) It is recommended that the backlight power must be turned on after the power supply for LCD and the interface signal is valid.

5. OPTICAL CHARACTERISTICS

5.1 TEST CONDITIONS

Item	Symbol	Value	Unit
Ambient Temperature	Ta	25±2	°C
Ambient Humidity	Ha	50±10	%RH
Supply Voltage	V _{CC}	3.3	V
Input Signal	According to typical value in "3. ELECTRICAL CHARACTERISTICS"		
LED Light Bar Input Current	I _L	54	mA

The measurement methods of optical characteristics are shown in Section 5.2. The following items should be measured under the test conditions described in Section 5.1 and stable environment shown in Note (5).

5.2 OPTICAL SPECIFICATIONS

Item		Symbol	Condition	Min.	Typ.	Max.	Unit	Note
Contrast Ratio		CR		300	500	-	-	(2), (5) (7)
Response Time		T _R		-	8	12	ms	(3),(7)
		T _F		-	8	13	ms	
Average Luminance of White		L _{AVE}		180	220	-	cd/m ²	(4), (6) (7)
Color Chromaticity	Red	R _x	θ _x =0°, θ _y =0° Viewing Normal Angle	Typ - 0.03	0.595	Typ + 0.03	-	(1),(7)
		R _y			0.345		-	
	Green	G _x			0.320		-	
		G _y			0.565		-	
	Blue	B _x			0.155		-	
		B _y			0.130		-	
	White	W _x			0.313		-	
		W _y			0.329		-	
Viewing Angle	Horizontal	θ _{x+}	CR≥10	40	45		Deg.	(1),(5) (7)
		θ _{x-}		40	45	-		
	Vertical	θ _{y+}		15	20	-		
		θ _{y-}		40	45	-		
White Variation of 5 and 13 Points		δW _{5p}	θ _x =0°, θ _y =0°	80	-	-	%	(5),(6)
		δW _{13p}	θ _x =0°, θ _y =0°	65	-	-	%	(7)

Note (1) Definition of Viewing Angle (θ_x , θ_y)

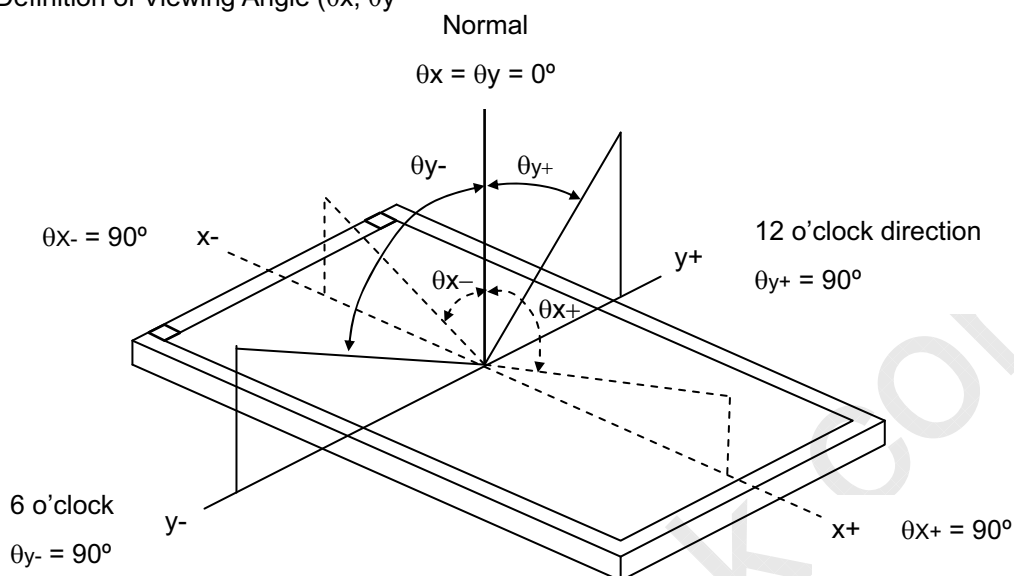

Note (2) Definition of Contrast Ratio (CR):

The contrast ratio can be calculated by the following expression.

$$\text{Contrast Ratio (CR)} = L_{63} / L_0$$

L₆₃: Luminance of gray level 63

L₀: Luminance of gray level 0

$$\text{CR} = \text{CR} (1)$$

CR (X) is corresponding to the Contrast Ratio of the point X at Figure in Note (6).

Note (3) Definition of Response Time (T_R , T_F):

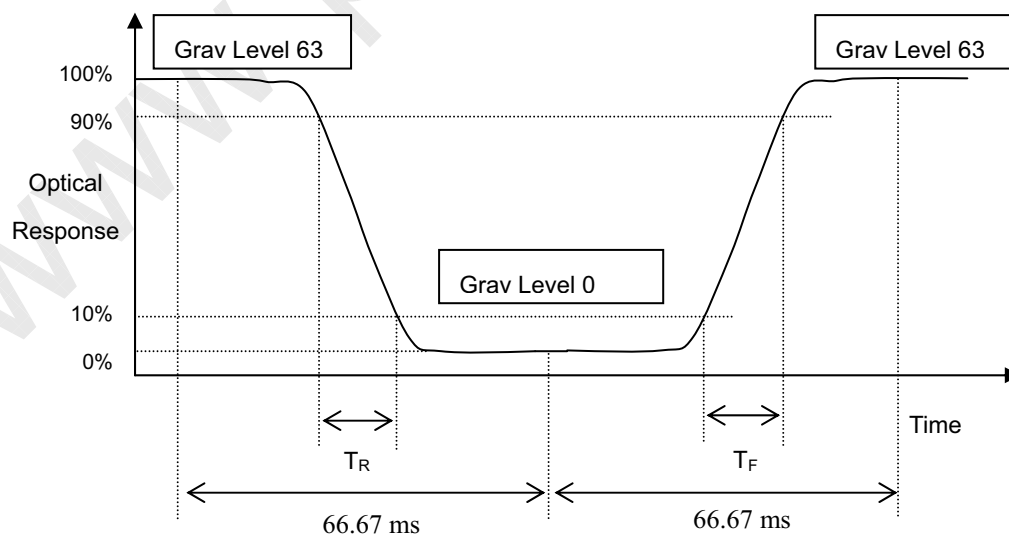

Note (4) Definition of Average Luminance of White (L_{AVE}):

Measure the luminance of gray level 63 at 5 points

$$L_{AVE} = [L(1) + L(2) + L(3) + L(4) + L(5)] / 5$$

L(x) is corresponding to the luminance of the point X at Figure in Note (6)

Note (5) Measurement Setup:

The LCD module should be stabilized at given temperature for 20 minutes to avoid abrupt temperature change during measuring. In order to stabilize the luminance, the measurement should be executed after lighting Backlight for 20 minutes in a windless room.

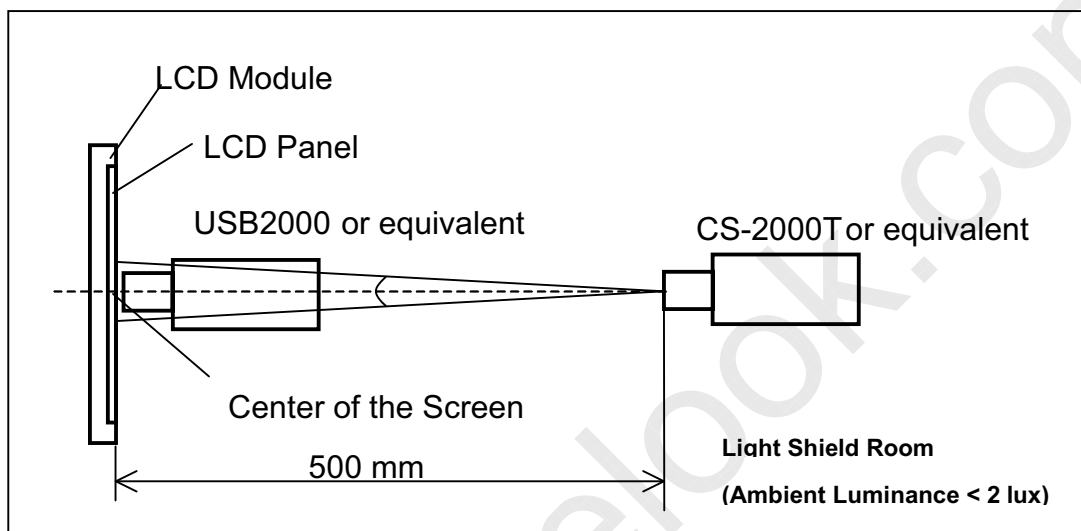

Note (6) Definition of White Variation (δW):

Measure the luminance of gray level 63 at 5 points

$$\delta W_{5p} = \{ \text{Minimum} [L(1) \sim L(5)] / \text{Maximum} [L(1) \sim L(5)] \} * 100\%$$

$$\delta W_{13p} = \{ \text{Minimum} [L(1) \sim L(13)] / \text{Maximum} [L(1) \sim L(13)] \} * 100\%$$

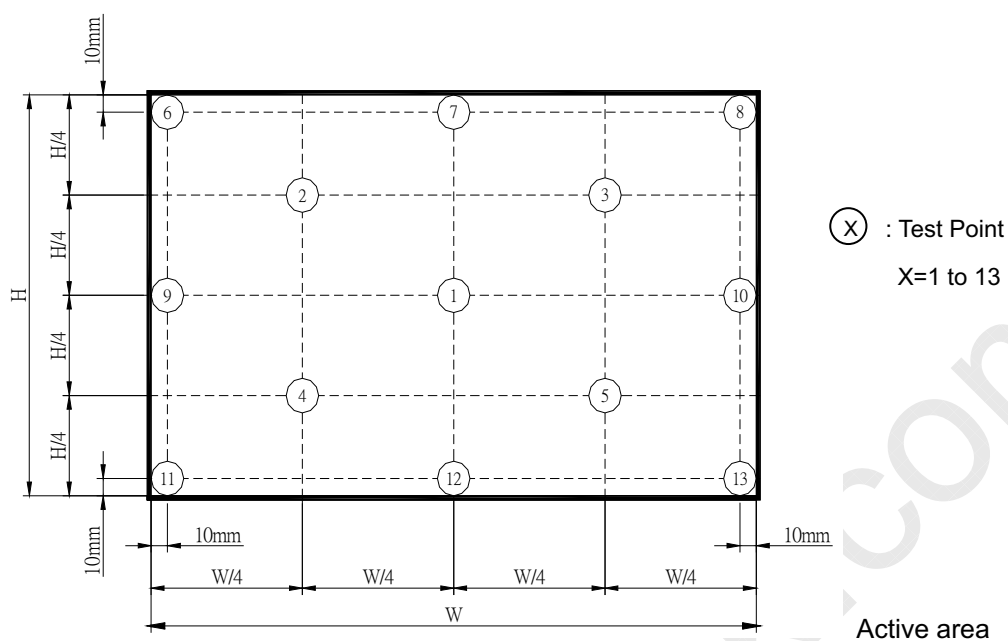

Note (7) The listed optical specifications refer to the initial value of manufacture, but the condition of the specifications after long-term operation will not be warranted.

6. RELIABILITY TEST ITEM

Test Item	Test Condition	Note
High Temperature Storage Test	60°C, 240 hours	(1) (2)
Low Temperature Storage Test	-20°C, 240 hours	
Thermal Shock Storage Test	-20°C, 0.5hour \longleftrightarrow 60°C, 0.5hour; 100cycles, 1hour/cycle	
High Temperature Operation Test	50°C, 240 hours	
Low Temperature Operation Test	0°C, 240 hours	
High Temperature & High Humidity Operation Test	50°C, RH 80%, 240hours	
ESD Test (Operation)	150pF, 330 Ω , 1sec/cycle Condition 1 : Contact Discharge, \pm 8KV Condition 2 : Air Discharge, \pm 15KV	(1)
Shock (Non-Operating)	220G, 2ms, half sine wave, 1 time for each direction of \pm X, \pm Y, \pm Z	(1)(3)
Vibration (Non-Operating)	1.5G / 10-500 Hz, Sine wave, 30 min/cycle, 1cycle for each X, Y, Z	(1)(3)

Note (1) criteria : Normal display image with no obvious non-uniformity and no line defect.

Note (2) Evaluation should be tested after storage at room temperature for more than two hour

Note (3) At testing Vibration and Shock, the fixture in holding the module has to be hard and rigid enough so that the module would not be twisted or bent by the fixture.

7. PACKING

7.1 MODULE LABEL

The barcode nameplate is pasted on each module as illustration, and its definitions are as following explanation.



- (a) Model Name: N133BGE - L31
 (b) Revision: Rev. XX, for example: C1, C2 ...etc.
 (c) Serial ID: XXXXXXYMDLNNNN

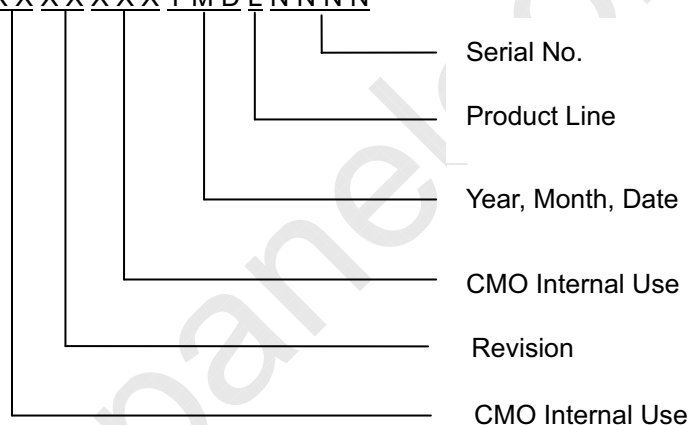

Serial ID includes the information as below:

- (a) Manufactured Date: Year: 0~9, for 2010~2019
 Month: 1~9, A~C, for Jan. ~ Dec.
 Day: 1~9, A~Y, for 1st to 31st, exclude I, O and U
- (b) Revision Code: cover all the change
- (c) Serial No.: Manufacturing sequence of product
- (d) Product Line: 1 -> Line1, 2 -> Line 2, ...etc.
- (e) Dell 2D label contains information as below:

(e-1) Serial ID: CN-065MJF-70896-YMD-XXXX-A00

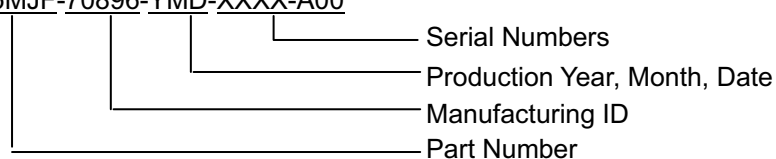

(e-2) Production location: Made in XXXX.

(e-3) ZZZ :Revision code: X00, X10, X20, A00..etc.

SST (WS)	X00,X01,X02,...X09
PT (ES)	X10,X11,X12,...X19
ST (CS)	X20,X21,X23,...X29
XB (MP)	A00,A01,A02,...A99

7.2 DELL Carton LABEL

Dell carton label contains information as below:



(a) PKG ID: 04688-70896-YMD-XXXXXX-065MJF-ZZ

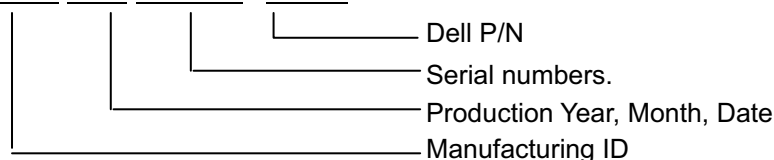

(b) Production location: Made in XXXX.

(c) Revision code: X00, X10, X20, A00..etc.

(d) BOX Quantity :ZZ

7.3 CARTON

Box Dimensions : 540(L)*450(W)*320(H)
 Weight: Approx. 17kg(40 module .per. 1 box)

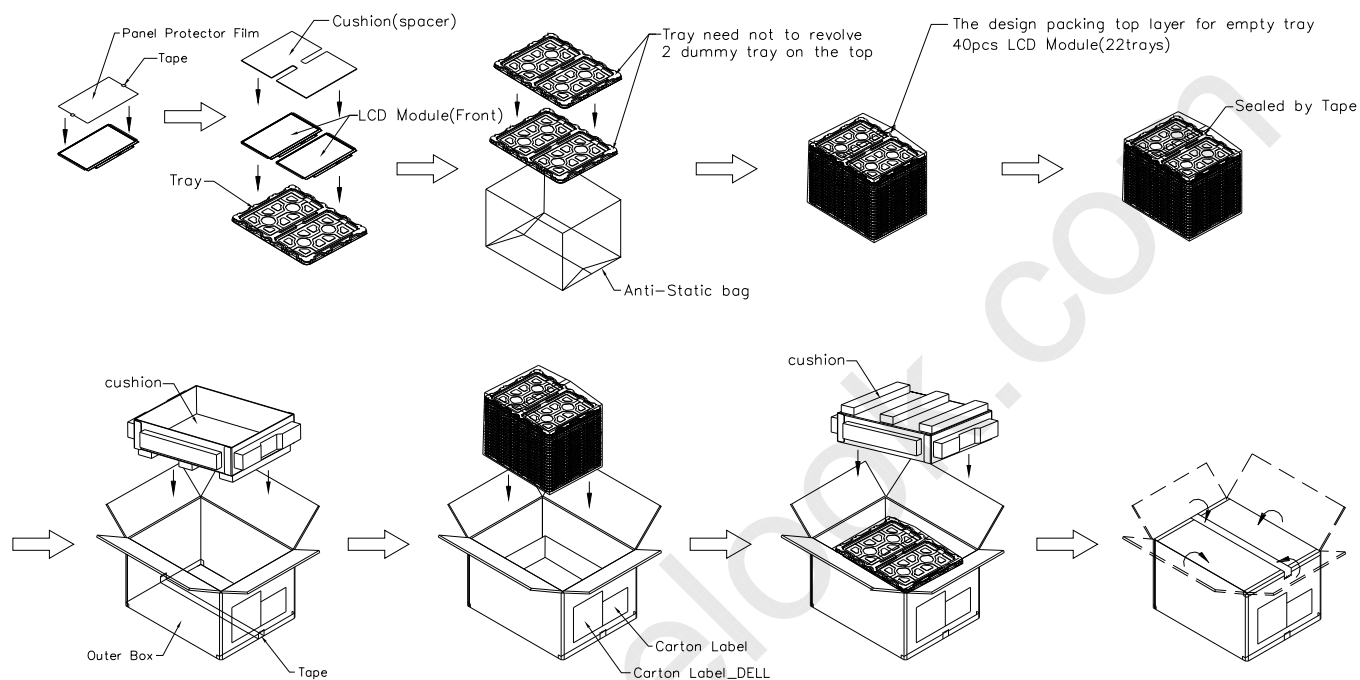
Figure. 7-3 Packing method

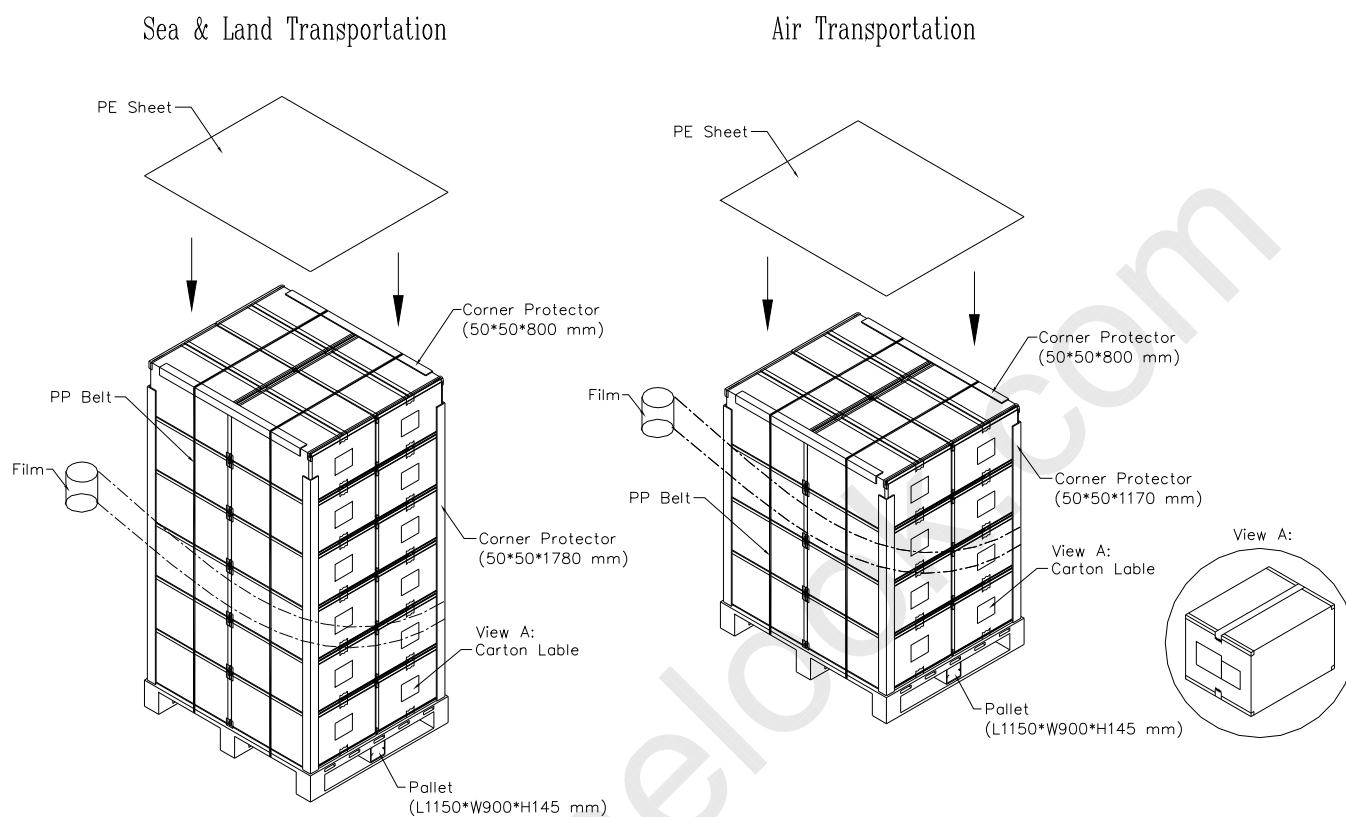
7.4 PALLET

Figure. 7-4 Packing method

8. PRECAUTIONS

8.1 HANDLING PRECAUTIONS

- (1) The module should be assembled into the system firmly by using every mounting hole. Be careful not to twist or bend the module.
- (2) While assembling or installing modules, it can only be in the clean area. The dust and oil may cause electrical short or damage the polarizer.
- (3) Use fingerstalls or soft gloves in order to keep display clean during the incoming inspection and assembly process.
- (4) Do not press or scratch the surface harder than a HB pencil lead on the panel because the polarizer is very soft and easily scratched.
- (5) If the surface of the polarizer is dirty, please clean it by some absorbent cotton or soft cloth. Do not use Ketone type materials (ex. Acetone), Ethyl alcohol, Toluene, Ethyl acid or Methyl chloride. It might permanently damage the polarizer due to chemical reaction.
- (6) Wipe off water droplets or oil immediately. Staining and discoloration may occur if they left on panel for a long time.
- (7) If the liquid crystal material leaks from the panel, it should be kept away from the eyes or mouth. In case of contacting with hands, legs or clothes, it must be washed away thoroughly with soap.
- (8) Protect the module from static electricity, it may cause damage to the C-MOS Gate Array IC.
- (9) Do not disassemble the module.
- (10) Do not pull or fold the LED wire.
- (11) Pins of I/F connector should not be touched directly with bare hands.

8.2 STORAGE PRECAUTIONS

- (1) High temperature or humidity may reduce the performance of module. Please store LCD module within the specified storage conditions.
- (2) It is dangerous that moisture come into or contacted the LCD module, because the moisture may damage LCD module when it is operating.
- (3) It may reduce the display quality if the ambient temperature is lower than 10 °C. For example, the response time will become slowly, and the starting voltage of LED will be higher than the room temperature.

8.3 OPERATION PRECAUTIONS

- (1) Do not pull the I/F connector in or out while the module is operating.
- (2) Always follow the correct power on/off sequence when LCD module is connecting and operating. This can prevent the CMOS LSI chips from damage during latch-up.
- (3) The startup voltage of Backlight is approximately 1000 Volts. It may cause electrical shock while assembling with converter. Do not disassemble the module or insert anything into the Backlight unit.

Appendix. EDID DATA STRUCTURE

The EDID (Extended Display Identification Data) data formats are to support displays as defined in the VESA Plug & Display and FPD standards.

Byte # (decimal)	Byte # (hex)	Field Name and Comments	Value (hex)	Value (binary)
0	0	Header , Fixed	00	00000000
1	1	Header , Fixed	FF	11111111
2	2	Header , Fixed	FF	11111111
3	3	Header , Fixed	FF	11111111
4	4	Header , Fixed	FF	11111111
5	5	Header , Fixed	FF	11111111
6	6	Header , Fixed	FF	11111111
7	7	Header , Fixed	00	00000000
8	8	ID system manufacturer name	0D	00001101
9	9	ID system manufacturer name	AF	10101111
10	0A	ID system Product Code (LSB)	32	00110010
11	0B	ID system Product Code (MSB)	13	00010011
12	0C	32-bit serial # Unused(01h for VESA, 00h for SPWG)	00	00000000
13	0D	32-bit serial # Unused(01h for VESA, 00h for SPWG)	00	00000000
14	0E	32-bit serial # Unused(01h for VESA, 00h for SPWG)	00	00000000
15	0F	32-bit serial # Unused(01h for VESA, 00h for SPWG)	00	00000000
16	10	Week of manufacture 1 - 53 (unused: 00h)	23	00100011
17	11	Year of manufacture year - 1990(unsed:00h)	14	00010100
18	12	Version=1	01	00000001
19	13	Revision=4	04	00000100
20	14	Vedio Input Definition	90	10010000
21	15	Active area horizontal 29.341cm	1D	00011101
22	16	Active area vertical 16.496cm	10	00010000
23	17	Display Gamma (Gamma = "2.2")	78	01111000
24	18	Feature support	02	00000010
25	19	Rx1, Rx0, Ry1, Ry0, Gx1, Gx0, Gy1, Gy0	98	10011000
26	1A	Bx1, Bx0, By1, By0, Wx1, Wx0, Wy1, Wy0	55	01010101
27	1B	Rx=0.584	95	10010101
28	1C	Ry=0.349	59	01011001
29	1D	Gx=0.338	56	01010110
30	1E	Gy=0.574	93	10010011
31	1F	Bx=0.157	28	00101000
32	20	By=0.126	20	00100000
33	21	Wx=0.313	50	01010000
34	22	Wy=0.329	54	01010100
35	23	Established timings 1	00	00000000
36	24	Established timings 2 (1366x768@60Hz)	00	00000000
37	25	No manufacturer's specific timing	00	00000000
38	26	Standard timing ID # 1	01	00000001
39	27	Standard timing ID # 1	01	00000001
40	28	Standard timing ID # 2	01	00000001
41	29	Standard timing ID # 2	01	00000001

42	2A	Standard timing ID # 3	01	00000001
43	2B	Standard timing ID # 3	01	00000001
44	2C	Standard timing ID # 4	01	00000001
45	2D	Standard timing ID # 4	01	00000001
46	2E	Standard timing ID # 5	01	00000001
47	2F	Standard timing ID # 5	01	00000001
48	30	Standard timing ID # 6	01	00000001
49	31	Standard timing ID # 6	01	00000001
50	32	Standard timing ID # 7	01	00000001
51	33	Standard timing ID # 7	01	00000001
52	34	Standard timing ID # 8	01	00000001
53	35	Standard timing ID # 8	01	00000001
54	36	Detailed timing description # 1 Pixel clock ("70.47MHz", According to VESA CVT Rev1.4)	87	10000111
55	37	# 1 70.47MHz/10000 =7047=1B87(Hex)	1B	00011011
56	38	# 1 H active ("1366")	56	01010110
57	39	# 1 H blank ("132")	84	10000100
58	3A	# 1 H active : H blank ("1366 : 132")	50	01010000
59	3B	# 1 V active ("768")	00	00000000
60	3C	# 1 V blank ("16")	10	00010000
61	3D	# 1 V active : V blank ("768 :16")	30	00110000
62	3E	# 1 H sync offset ("38")	26	00100110
63	3F	# 1 H sync pulse width ("26")	1A	00011010
64	40	# 1 V sync offset : V sync pulse width ("2 : 4")	24	00100100
65	41	# 1 H sync offset : H sync pulse width : V sync offset : V sync width ("38: 26 : 2 : 4")	00	00000000
66	42	# 1 H image size ("293 mm")	25	00100101
67	43	# 1 V image size ("164 mm")	A4	10100100
68	44	# 1 H image size : V image size ("293 : 164")	10	00010000
69	45	# 1 H boarder ("0")	00	00000000
70	46	# 1 V boarder ("0")	00	00000000
71	47	Non-interlaced, Normal Display, Digital separate, Positive Hsync, Negative Vsync	1A	00011010
72	48	Detailed timing description # 1 Pixel clock ("53.74MHz", According to VESA CVT Rev1.4)	FE	11111110
73	49	# 2 53.74MHz/10000 =5374=14FE(Hex)	14	00010100
74	4A	# 2 H active ("1366")	56	01010110
75	4B	# 2 H blank ("270")	0E	00001110
76	4C	# 2 H active : H blank ("1366 : 270")	51	01010001
77	4D	# 2 V active ("768")	00	00000000
78	4E	# 2 V blank ("53")	35	00110101
79	4F	# 2 V active : V blank ("768 :53")	30	00110000
80	50	# 2 H sync offset ("81")	51	01010001
81	51	# 2 H sync pulse width ("54")	36	00110110
82	52	# 2 V sync offset : V sync pulse width ("5 : 9")	59	01011001
83	53	# 2 H sync offset : H sync pulse width : V sync offset : V sync width ("81: 54 : 5 : 9")	00	00000000
84	54	# 2 H image size ("293 mm")	25	00100101
85	55	# 2 V image size ("164 mm")	A4	10100100

86	56	# 2 H image size : V image size ("293 : 164")	10	00010000
87	57	# 2 H boarder ("0")	00	00000000
88	58	# 2 V boarder ("0")	00	00000000
89	59	Non-interlaced, Normal Display, Digital separate, Positive Hsync, Negative Vsync	1A	00011010
90	5A	Flag	00	00000000
91	5B	Flag	00	00000000
92	5C	Flag	00	00000000
93	5D	Data Type Tag: Alphanumeric Data String (ASCII)	FE	11111110
94	5E	Flag	00	00000000
95	5F	Dell P/N 1st Character "6"	36	00110110
96	60	Dell P/N 2nd Character "5"	35	00110101
97	61	Dell P/N 3rd Character "M"	4D	01001101
98	62	Dell P/N 4th Character "J"	4A	01001010
99	63	Dell P/N 5th Character "F"	46	01000110
100	64	EDID Revision	80	10000000
101	65	Manufacturer P/N "1"	31	00110001
102	66	Manufacturer P/N "3"	33	00110011
103	67	Manufacturer P/N "3"	33	00110011
104	68	Manufacturer P/N "B"	42	01000010
105	69	Manufacturer P/N "G"	47	01000111
106	6A	Manufacturer P/N "E"	45	01000101
107	6B	Manufacturer P/N (If <13 char, then terminate with ASCII code 0Ah, set remaining char = 20h)	0A	00001010
108	6C	Flag	00	00000000
109	6D	Flag	00	00000000
110	6E	Flag	00	00000000
111	6F	Data Type Tag: Manufacturer Specified Data 00	00	00000000
112	70	Flag	00	00000000
113	71	Color Management	00	00000000
114	72	Panel Type and Revision	41	01000001
115	73	Frame Rate	31	00110001
116	74	Light Controller Interface and Maximum Luminance	96	10010110
117	75	Front Surface / Polarizer and Pixel Structure	00	00000000
118	76	Multi-Media Features	10	00010000
119	77	Multi-Media Features	00	00000000
120	78	Special Features	00	00000000
121	79	Special Feature	01	00000001
122	7A	Special Features	01	00000001
123	7B	(If <13 char, then terminate with ASCII code 0Ah, set remaining char = 20h)	0A	00001010
124	7C	(If <13 char, then terminate with ASCII code 0Ah, set remaining char = 20h)	20	00100000
125	7D	(If <13 char, then terminate with ASCII code 0Ah, set remaining char = 20h)	20	00100000
126	7E	No extension	00	00000000
127	7F	Checksum	D7	11010111

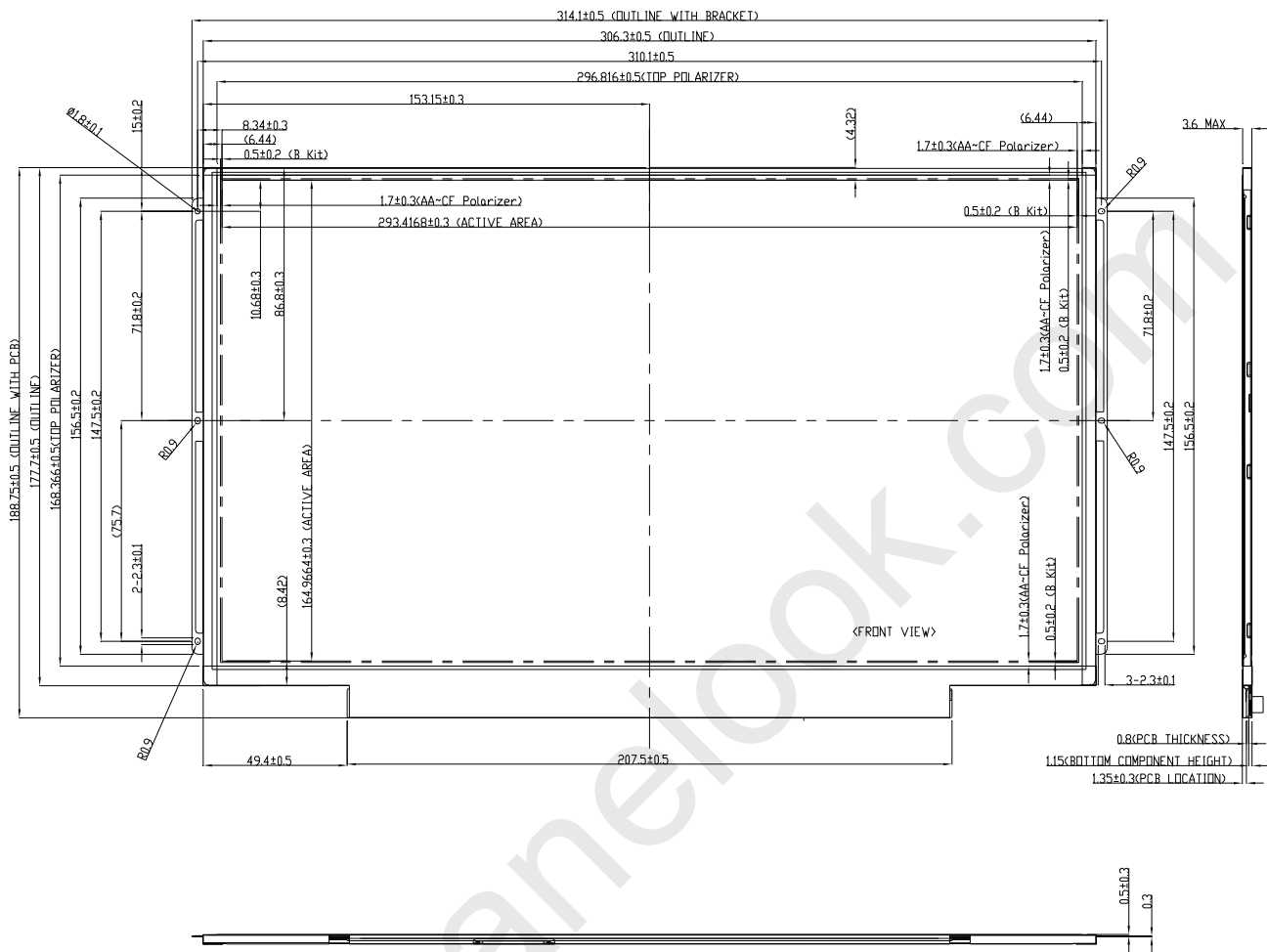
Appendix. OUTLINE DRAWING

NOTES :

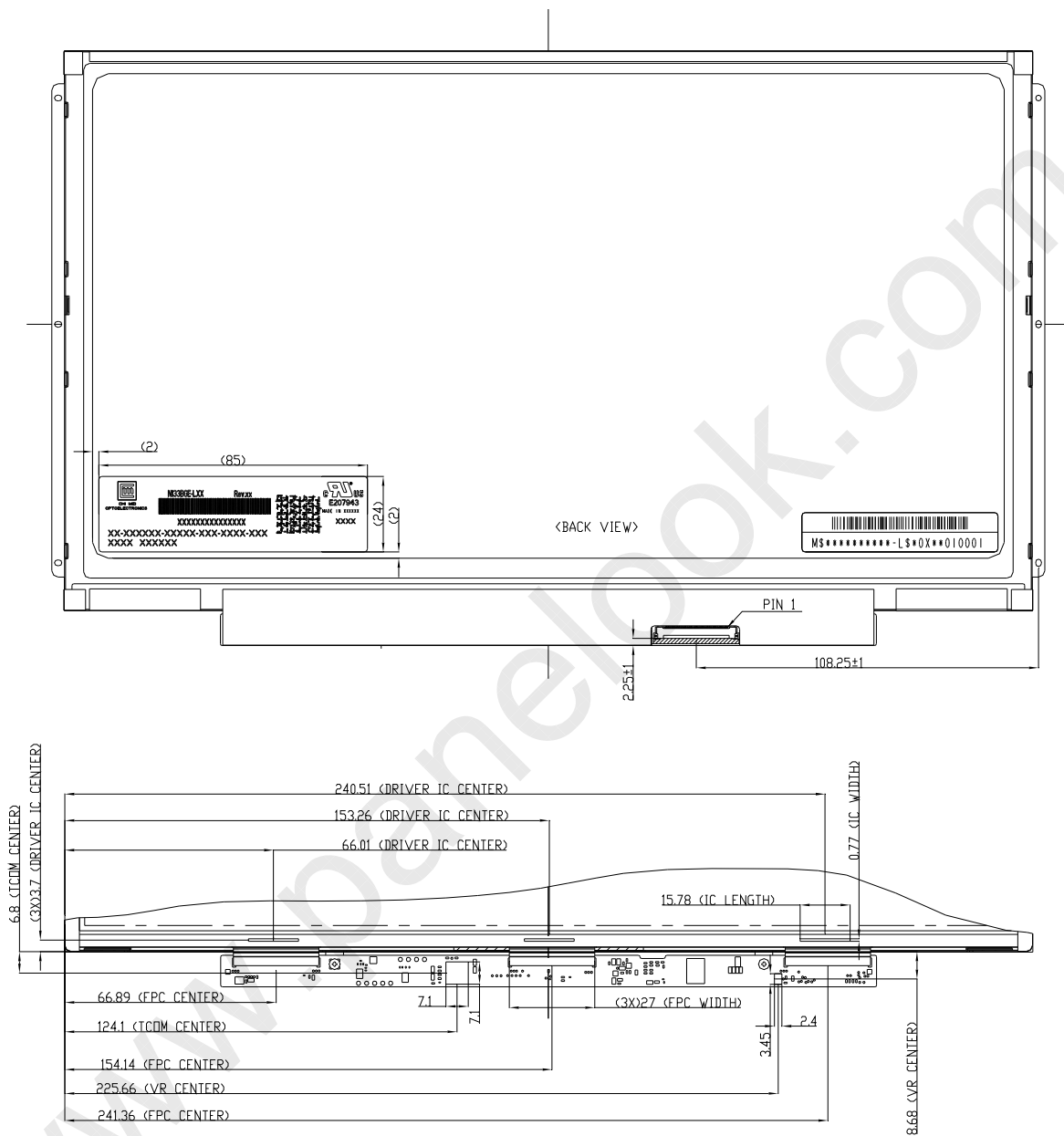
1. FLATNESS 0.5 mm MAX
2. "< >" MARKS THE REFERENCE DIMENSIONS.
3. LCD MODULE INPUT CONNECTOR: 20455-040E-12 (I-PEX) OR EQUIVALENT
4. IN ORDER TO AVOID ABNORMAL DISPLAY, POOLING AND WHITE SPOT, NO OVERLAPPING IS SUGGESTED AT CABLES, ANTENNAS, CAMERA, WLAN, WAM OR OTHER FOREIGN OBJECTS OVER COF DRIVER IC, TCON AND VR LOCATION.



DRIVER IC, FPC, TCON, AND VR LOCATIONS
SEE NOTE 4 FOR EXPLANATION.