

Doc. Number:

- Tentative Specification
- Preliminary Specification
- Approval Specification

MODEL NO.: N133HSE

SUFFIX: D31

Customer: Common Model	
APPROVED BY	SIGNATURE
Name / Title	_____
Note	_____
<p>_____</p> <p>Please return 1 copy for your confirmation with your signature and comments.</p>	

Approved By 楊竣傑 2013-02-07 17:11:11 CST	Checked By 曹文彬 2013-01-10 15:59:28 CST	Prepared By 歐陽志全 2013-01-10 11:04:24 CST
---	--	--

CONTENTS

1. GENERAL DESCRIPTION	4
1.1 OVERVIEW	4
1.2 GENERAL SPECIFICATIONS	4
2. MECHANICAL SPECIFICATIONS	4
2.1 CONNECTOR TYPE	4
3. ABSOLUTE MAXIMUM RATINGS	5
3.1 ABSOLUTE RATINGS OF ENVIRONMENT	5
3.2 ABSOLUTE RATINGS OF ENVIRONMENT (OPEN CELL)	5
3.3 ELECTRICAL ABSOLUTE RATINGS.....	6
3.3.1 TFT LCD MODULE	6
4. ELECTRICAL SPECIFICATIONS.....	7
4.1 FUNCTION BLOCK DIAGRAM.....	7
4.2. INTERFACE CONNECTIONS	7
4.3 ELECTRICAL CHARACTERISTICS.....	10
4.3.1 LCD ELETRONICS SPECIFICATION.....	10
4.4 DISPLAY PORT SIGNAL TIMING SPECIFICATION	12
4.4.1 DISPLAY PORT INTERFACE	12
4.5 DISPLAY TIMING SPECIFICATIONS	13
4.6 POWER ON/OFF SEQUENCE	14
5. OPTICAL CHARACTERISTICS	16
5.1 TEST CONDITIONS.....	16
5.2 OPTICAL SPECIFICATIONS	16
6. PACKING.....	19
6.1 CMI OPEN CELL LABEL.....	19
6.2 PACKAGE RELIABILITY	20
6.3 CARTON	20
6.4 PALLET.....	21
7. PRECAUTIONS.....	22
7.1 HANDLING PRECAUTIONS.....	22
7.2 STORAGE PRECAUTIONS	22
7.3 OPERATION PRECAUTIONS.....	22
Appendix. EDID DATA STRUCTURE.....	23
Appendix. OUTLINE DRAWING	26

REVISION HISTORY

Version	Date	Page	Description
2.0	Nov. 6, 2012	All	Approval Spec. Ver. 2.0 was first issued.

1. GENERAL DESCRIPTION

1.1 OVERVIEW

N133HSE – D31 is a 13.3" TFT Liquid Crystal Display with 30 pins eDP interface. This product supports 1920 x 1080 FHD mode and can display 16,777,216 colors. The backlight unit and converter are not built in.

1.2 GENERAL SPECIFICATIONS

Item	Specification	Unit	Note
Screen Size	13.3 diagonal		
Driver Element	a-si TFT active matrix	-	-
Pixel Number	1920 x R.G.B. x 1080	pixel	-
Pixel Pitch	0.1529 (H) x 0.1529 (V)	mm	-
Pixel Arrangement	RGB vertical stripe	-	-
Display Colors	16,777,216	color	-
Transmissive Mode	Normally black	-	-
Surface Treatment	Hard coating (3H), AG	-	-

2. MECHANICAL SPECIFICATIONS

item		Min.	Typ.	Max.	Unit	Note
Size	Horizontal (H) with PCB	301.77	301.97	302.17	mm	(1) (2)
	Horizontal (H) w/o PCB	301.77	301.97	302.17	mm	
	Vertical (V) with PCB	191.24	192.24	193.24	mm	
	Vertical (V) w/o PCB	174.99	175.19	175.39	mm	
	Thickness (T) with PCB	-	-	2.4	mm	
	Thickness (T) w/o PCB	-	-	1.22	mm	
Active Area	Horizontal	293.46	293.76	294.06	mm	
	Vertical	164.94	165.24	165.54	mm	
Weight (with polarizer release paper)		-	130	135	g	
I/F connector mounting position		The mounting inclination of the connector makes the screen center within $\pm 0.5\text{mm}$ as the horizontal.				

Note (1) Please refer to the attached drawings for more information of front and back outline dimensions.

(2) Connector mounting position

2.1 CONNECTOR TYPE

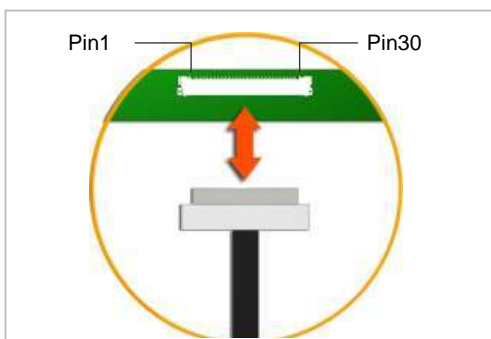

Please refer Appendix Outline Drawing for detail design.

eDP connector Part No.: IPEX-20455-030E-12 or FOXCONN GS13301-1110S-7H or equivalent

User's connector Part No: GS12401-1011P-9H or equivalent

LED Light-bar connector : STM-MSK24036P8A

3. ABSOLUTE MAXIMUM RATINGS

3.1 ABSOLUTE RATINGS OF ENVIRONMENT

Item	Symbol	Value		Unit	Note
		Min.	Max.		
Storage Temperature	T _{ST}	-20	+60	°C	(1)
Operating Ambient Temperature	T _{OP}	0	+50	°C	(1), (2)

Note (1) (a) 90 %RH Max. (Ta <= 40 °C).

(b) Wet-bulb temperature should be 39 °C Max. (Ta > 40 °C).

(c) No condensation.

Note (2) The temperature of panel surface should be 0 °C min. and 60 °C max.

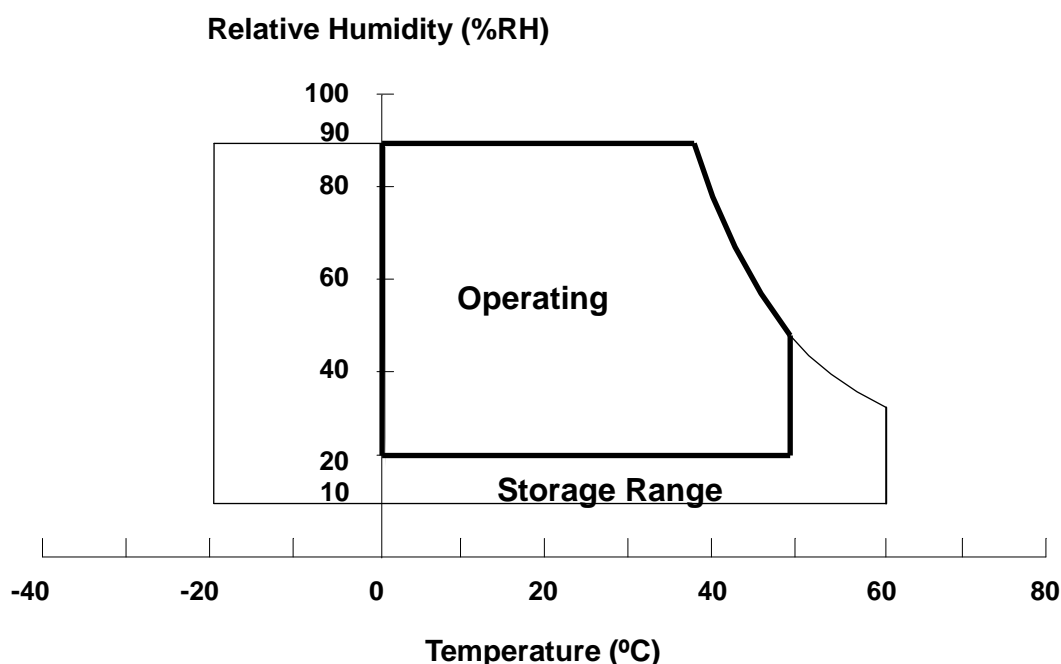

3.2 ABSOLUTE RATINGS OF ENVIRONMENT (OPEN CELL)

High temperature or humidity may reduce the performance of panel. Please store LCD panel within the specified storage conditions.

Storage Condition: With packing.

Storage temperature range: 25±5 °C.

Storage humidity range: 50±10%RH.

Shelf life: 30days

3.3 ELECTRICAL ABSOLUTE RATINGS

3.3.1 TFT LCD MODULE

Item	Symbol	Value		Unit	Note
		Min.	Max.		
Power Supply Voltage	VCCS	-0.3	+4.0	V	(1)
Logic Input Voltage	V _{IN}	-0.3	VCCS+0.3	V	
System PWM signal input for dimming	PWM_IN	-0.3	5	V	
Color Engine	CE_EN	-0.3	5	V	
Dynamic backlight control	CABC_EN	-0.3	5	V	

Note (1) Stresses beyond those listed in above "ELECTRICAL ABSOLUTE RATINGS" may cause permanent damage to the device. Normal operation should be restricted to the conditions described in "ELECTRICAL CHARACTERISTICS".

4. ELECTRICAL SPECIFICATIONS

4.1 FUNCTION BLOCK DIAGRAM

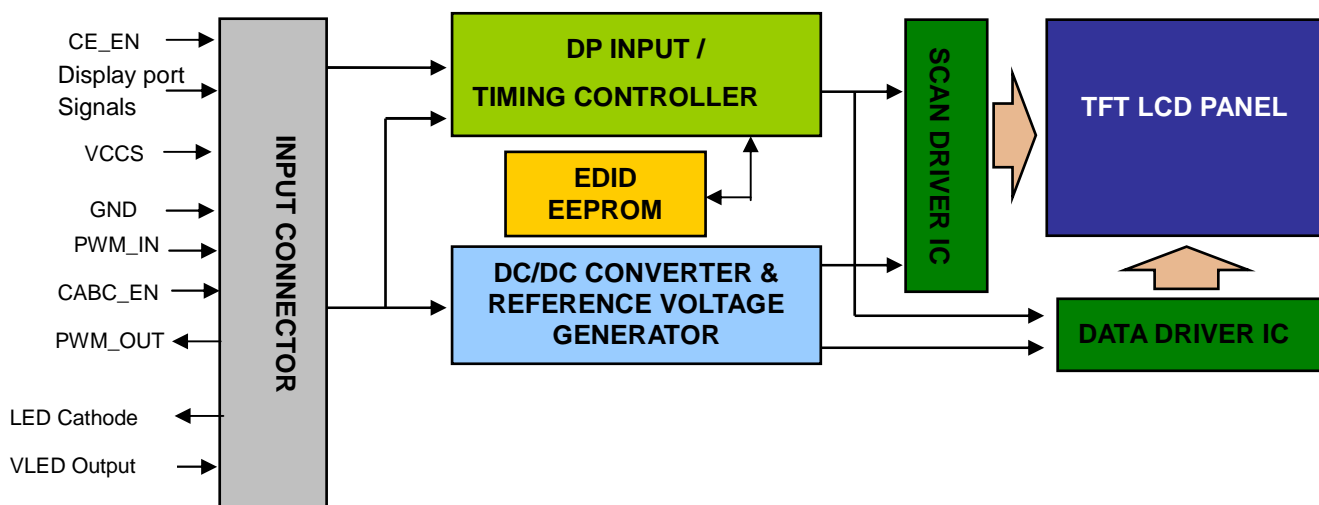

4.2. INTERFACE CONNECTIONS

PIN ASSIGNMENT

Pin	Symbol	Description	Remark
1	CE_EN	Color Engine Enable Input	
2	H_GND	High Speed Ground	
3	ML1-	Complement Signal-Lane 1	
4	ML1+	True Signal-Main Lane 1	
5	H_GND	High Speed Ground	
6	ML0-	Complement Signal-Lane 0	
7	ML0+	True Signal-Main Lane 0	
8	H_GND	High Speed Ground	
9	AUX+	True Signal-Auxiliary Channel	
10	AUX-	Complement Signal-Auxiliary Channel	
11	H_GND	High Speed Ground	
12	VCCS	Power Supply +3.3 V (typical)	
13	VCCS	Power Supply +3.3 V (typical)	
14	BIST	Panel self test	
15	VSS	Ground	
16	HPD	Hot Plug Detect	
17	PWM_IN	System PWM signal input for dimming	
18	CABC_EN	CABC Enable Input	
19	PWM_OUT	Panel PWM signal output to system	
20	NC	No Connection (Reserve)	
21	LED-	LED Cathode	
22	LED-	LED Cathode	
23	LED-	LED Cathode	
24	LED-	LED Cathode	
25	NC	No Connection (Reserve)	

26	LED+	LED Anode	
27	LED+	LED Anode	
28	NC	No Connection (Reserve)	
29	CLKDVCOM	D-Vcom Clock	
30	DATAVCOM	D-Vcom Data	

Note (1) The first pixel is odd as shown in the following figure.

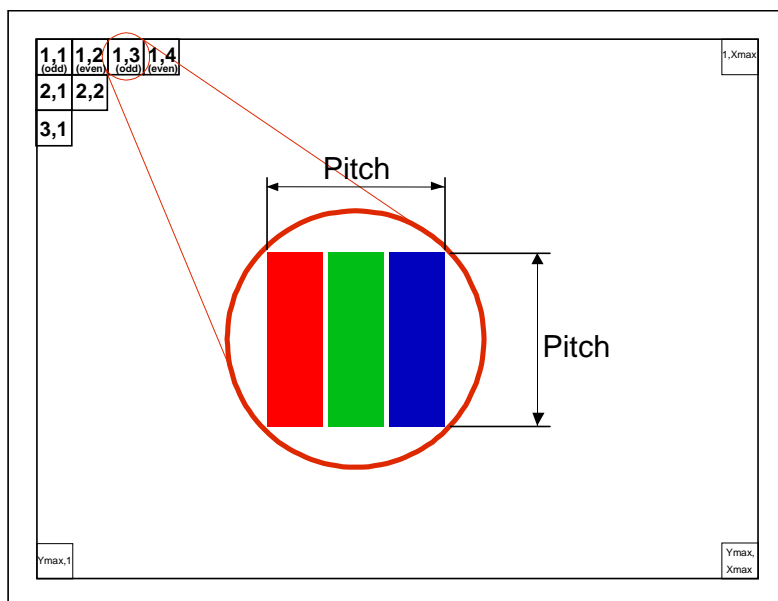

Note (2) The setting of CABC and CE function are as follows.

Pin	Enable	Disable
CE_EN	Hi	Lo or Open
CABC_EN	Hi	Lo or Open

Hi = High level, Lo = Low level.

Note (3) The I²C device addresses are defined as follows. The D-VCOM part is iML7978CL.

Component	Device Address							
	B7	B6	B5	B4	B3	B2	B1	WR
D-VCOM	1	0	0	1	1	1	1	X

4.2.2 LED CONVERTER OUTPUT PIN ASSIGNMENT

Pin	Symbol	Description	Remark
1	VLED Output	LED driver output	
2	VLED Output	LED driver output	
3	NC	No Connection (Reserve)	
4	LED_CA1	LED Cathode 1	
5	LED_CA2	LED Cathode 2	
6	LED_CA3	LED Cathode 3	
7	LED_CA4	LED Cathode 4	
8	NC	No Connection (Reserve)	

4.3 ELECTRICAL CHARACTERISTICS

4.3.1 LCD ELETRONICS SPECIFICATION

Parameter		Symbol	Value			Unit	Note
			Min.	Typ.	Max.		
Power Supply Voltage		VCCS	3.0	3.3	3.6	V	(1)-
HPD		High Level	3.0	-	3.6	V	V
		Low Level	0	-	0.4	V	V
Ripple Voltage		V _{RP}	-	50	-	mV	(1)-
CABC_EN Input Voltage	High Level	V _{IHCABC}	2.3	-	3.6	V	
	Low Level	V _{ILCABC}	0	-	0.4	V	
CE_EN Input Voltage	High Level	V _{IHCE}	2.3	-	3.6	V	
	Low Level	V _{ILCE}	0	-	0.4	V	
PWM Input Voltage	High Level	V _{IHPWM}	2.3	-	3.6	V	
	Low Level	V _{ILPWM}	0	-	0.4	V	
PWM Control Duty Ratio			5		100	%	
PWM Input Frequency		f _{PWM}	190	-	2K	Hz	
PWM Output Voltage	High Level	V _{OHPWMO}	2.0	-	3.6	V	
	Low Level	V _{OLPWMO}	0	-	0.8	V	
PWM Output Frequency		f _{PWM}	190	-	2K	Hz	
Inrush Current		I _{RUSH}	-	-	1.5	A	(1),(2)
Power Supply Current	Mosaic	I _{CC}	-	315	375	mA	(3)a
	White		-	352	412	mA	(3)b

Note (1) The ambient temperature is $T_a = 25 \pm 2$ °C.

Note (2) I_{RUSH}: the maximum current when VCCS is rising

I_S: the maximum current of the first 100ms after power-on

Measurement Conditions: Shown as the following figure. Test pattern: White.

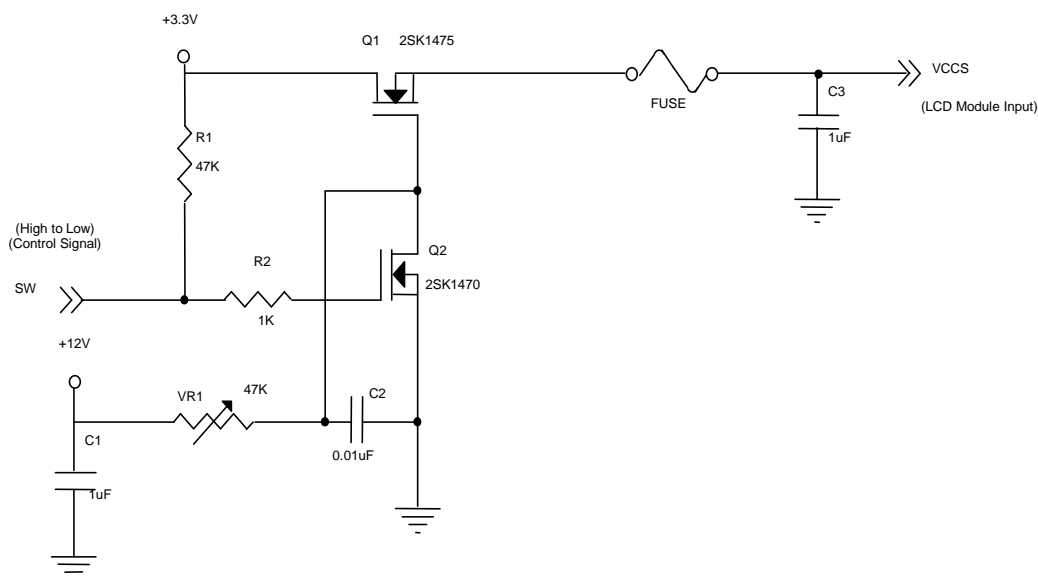

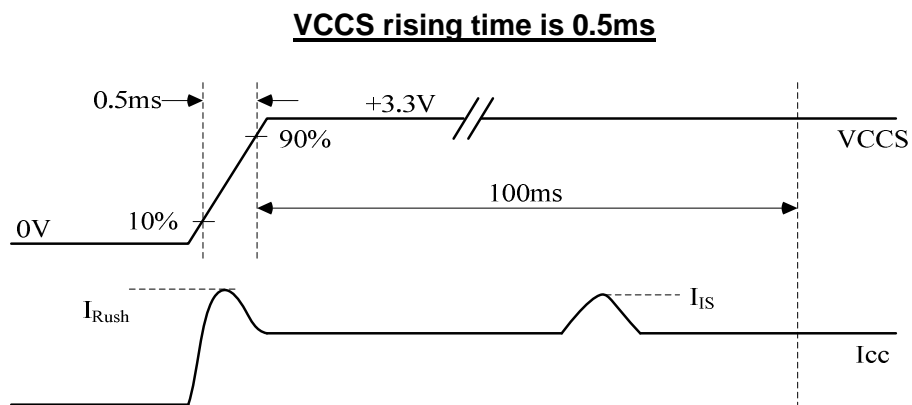

Note (3) The specified power supply current is under the conditions at VCCS = 3.3 V, Ta = 25 ± 2 °C, DC Current and f_v = 60 Hz, whereas a power dissipation check pattern below is displayed.

a. Mosaic Pattern

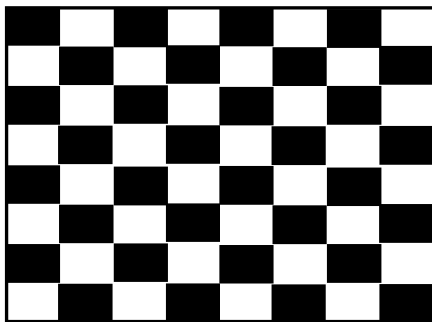

Active Area

b. White Pattern

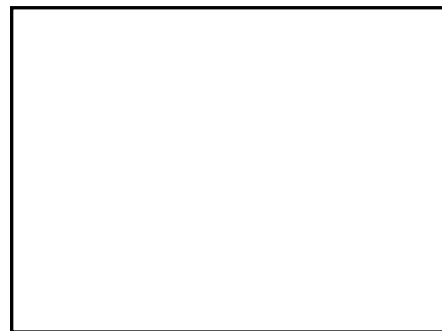

Active Area

4.4 DISPLAY PORT SIGNAL TIMING SPECIFICATION

4.4.1 DISPLAY PORT INTERFACE

Parameter	Symbol	Min.	Typ.	Max.	Unit	Notes
Differential Signal Common Mode Voltage(MainLink and AUX)	VCM	0		2	V	(1)(3)
AUX AC Coupling Capacitor	C _{AUX}	75		200	nF	(2)

Note (1) Display port interface related AC coupled signals should follow VESA DisplayPort Standard Version1. Revision 1a and VESA Embedded DisplayPort™ Standard Version 1.1.

(2) The AUX AC Coupling Capacitor should be placed on Source Devices.

(3)The source device should pass the test criteria described in DisplayPortCompliance Test Specification (CTS) 1.1

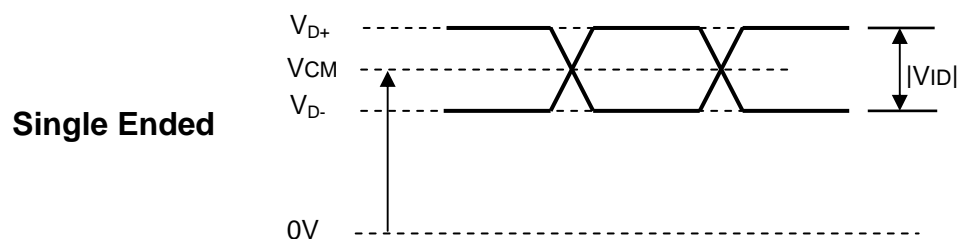

4.5 DISPLAY TIMING SPECIFICATIONS

The input signal timing specifications are shown as the following table and timing diagram.

Signal	Item	Symbol	Min.	Typ.	Max.	Unit	Note
DCLK	Frequency	1/Tc	116.17	138.78	142.77	MHz	-
DE	Vertical Total Time	TV	1103	1112	1462	TH	-
	Vertical Active Display Period	TVD	1080	1080	1080	TH	-
	Vertical Active Blanking Period	TVB	TV-TVD	32	TV-TVD	TH	-
	Horizontal Total Time	TH	2058	2080	2910	Tc	-
	Horizontal Active Display Period	THD	1920	1920	1920	Tc	-
	Horizontal Active Blanking Period	THB	TH-THD	160	TH-THD	Tc	-

INPUT SIGNAL TIMING DIAGRAM

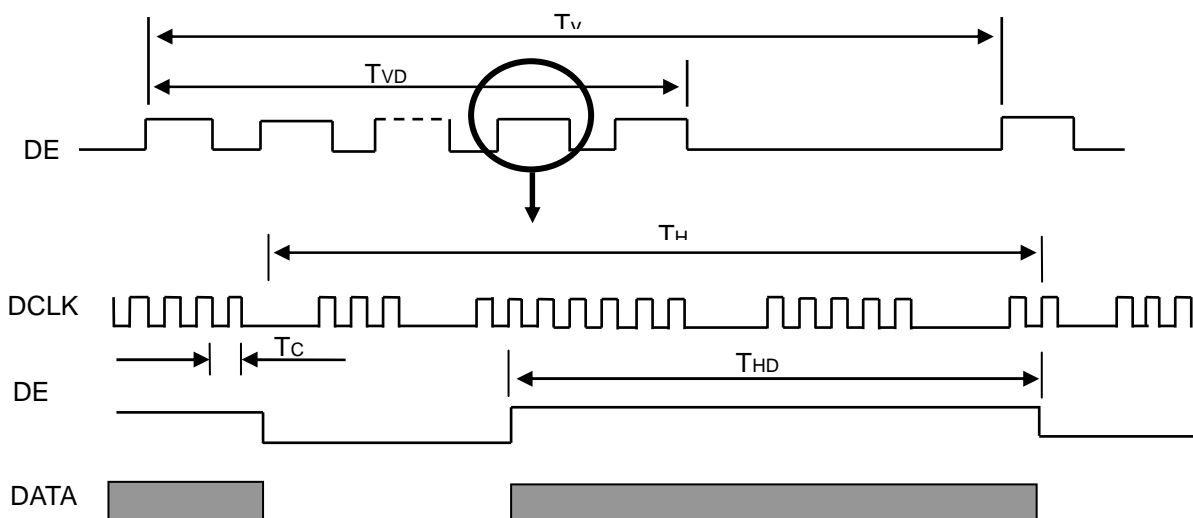

4.6 POWER ON/OFF SEQUENCE

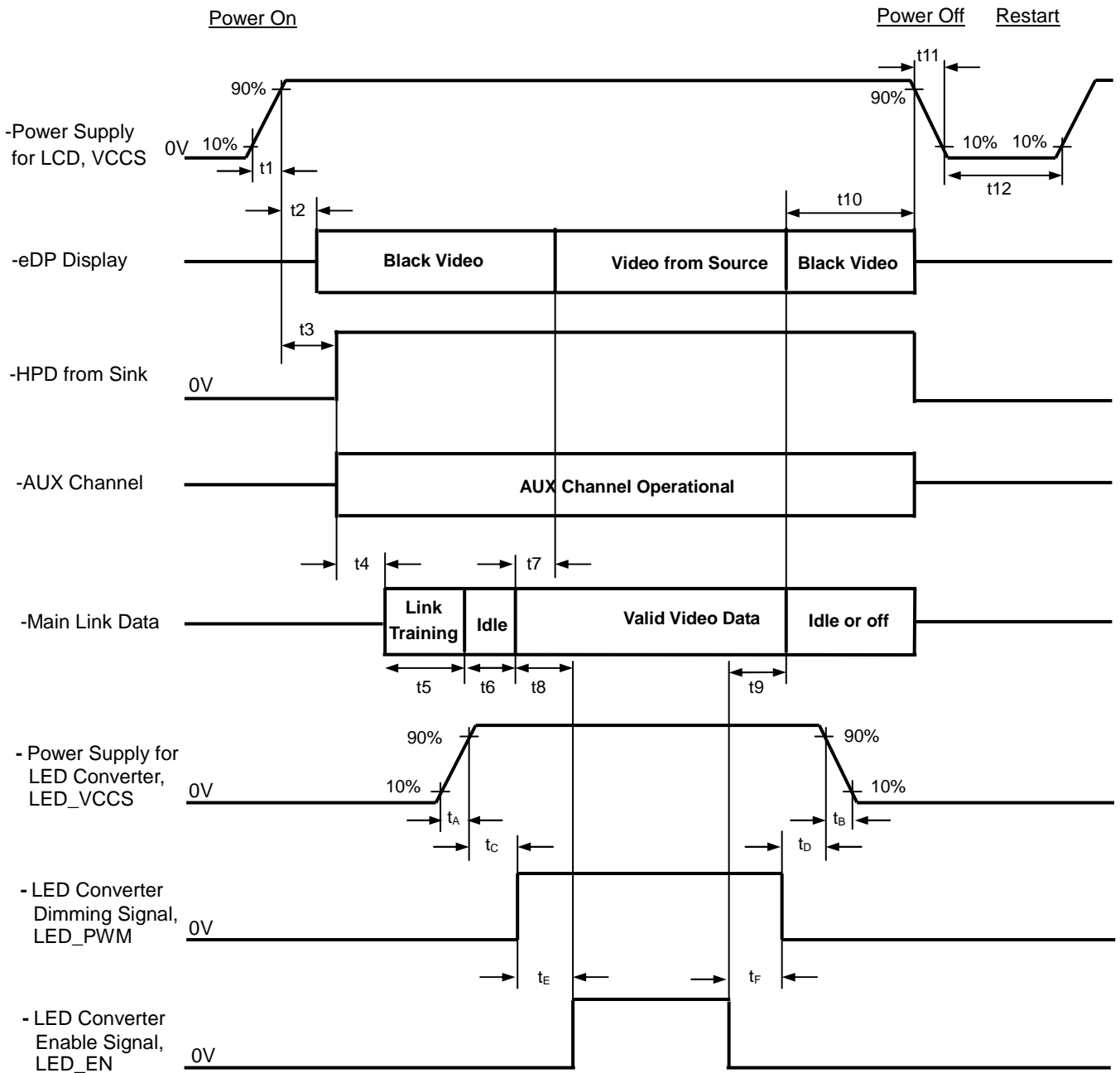

Timing Specifications:

Parameter	Description	Reqd. By	Value		Unit	Notes
			Min	Max		
t1	Power rail rise time, 10% to 90%	Source	0.5	10	ms	-
t2	Delay from LCD,VCCS to black video generation	Sink	0	200	ms	-
t3	Delay from LCD,VCCS to HPD high	Sink	0	200	ms	-
t4	Delay from HPD high to link training initialization	Source	-	-	ms	-
t5	Link training duration	Source	-	-	ms	-
t6	Link idle	Source	-	-	ms	-
t7	Delay from valid video data from Source to video on display	Sink	0	50	ms	-
t8	Delay from valid video data from Source to backlight on	Source	-	-	ms	-
t9	Delay from backlight off to end of valid video data	Source	-	-	ms	-
t10	Delay from end of valid video data from Source to power off	Source	0	500	ms	-
t11	VCCS power rail fall time, 90% to 10%	Source	0.5	10	ms	-
t12	VCCS Power off time	Source	500	-	ms	-
t _A	LED power rail rise time, 10% to 90%	Source	0.5	10	ms	-
t _B	LED power rail fall time, 90% to 10%	Source	0	10	ms	-
t _C	Delay from LED power rising to LED dimming signal	Source	10	-	ms	-
t _D	Delay from LED dimming signal to LED power falling	Source	10	-	ms	-
t _E	Delay from LED dimming signal to LED enable signal	Source	10	-	ms	-
t _F	Delay from LED enable signal to LED dimming signal	Source	10	-	ms	-

Note (1) Please don't plug or unplug the interface cable when system is turned on.

Note (2) Please avoid floating state of the interface signal during signal invalid period.

Note (3) It is recommended that the backlight power must be turned on after the power supply for LCD and the interface signal is valid.

5. OPTICAL CHARACTERISTICS

5.1 TEST CONDITIONS

Item	Symbol	Value	Unit
Ambient Temperature	Ta	25±2	°C
Ambient Humidity	Ha	50±10	%RH
Supply Voltage	V _{CC}	3.3	V
Input Signal	According to typical value in "3. ELECTRICAL CHARACTERISTICS"		
LED Light Bar Input Current	I _L	---	mA

The measurement methods of optical characteristics are shown in Section 5.2. The following items should be measured under the test conditions described in Section 5.1 and stable environment shown in Note (5).

5.2 OPTICAL SPECIFICATIONS

Item		Symbol	Condition	Min.	Typ.	Max.	Unit	Note
Color Chromaticity	Red	Rcx	$\theta_x=0^\circ, \theta_y=0^\circ$ CS-2000T Standard light source "C"	Typ - 0.03	0.664	Typ + 0.03	-	(0),(2), (5),(8)
		Rcy			0.327		-	
	Green	Gcx			0.303		-	
		Gcy			0.592		-	
	Blue	Bcx			0.142		-	
		Bcy			0.087		-	
	White	Wcx			0.332		-	
		Wcy			0.363		-	
	Center Transmittance				T%		$\theta_x=0^\circ, \theta_y=0^\circ$ CS-2000T, CMO BLU	
Contrast Ratio		CR		600	800		-	(2), (3)
Response Time		T _R	$\theta_x=0^\circ, \theta_y=0^\circ$		14	19	ms	(4)
		T _F			11	16	ms	
Transmittance uniformity		δT%	$\theta_x=0^\circ, \theta_y=0^\circ$ BM-13A			1.40	-	(2),(6)
Viewing Angle	Horizontal	θ_{x+}	CR≥10 BM-5A	80	89			(2),(5)
		θ_{x-}		80	89			
	Vertical	θ_{y+}		80	89			
		θ_{y-}		80	89			

Note (0) Light source is the standard light source "C" which is defined by CIE and driving voltages are based on suitable gamma voltages. The calculating method is as following :

1. Measure Module's and BLU's spectrums. White is without signal input and R, G, B are with signal input. BLU is supplied by CMI.
2. Calculate cell's spectrum.
3. Calculate cell's chromaticity by using the spectrum of standard light source "C"

Note (1) Light source is the BLU which is supplied by CMI and driving voltages are based on suitable gamma voltages. White is without signal input and R, G, B are with signal input. Spec is judged by CMI's golden sample.

Note (2) Definition of Viewing Angle (θ_x, θ_y):

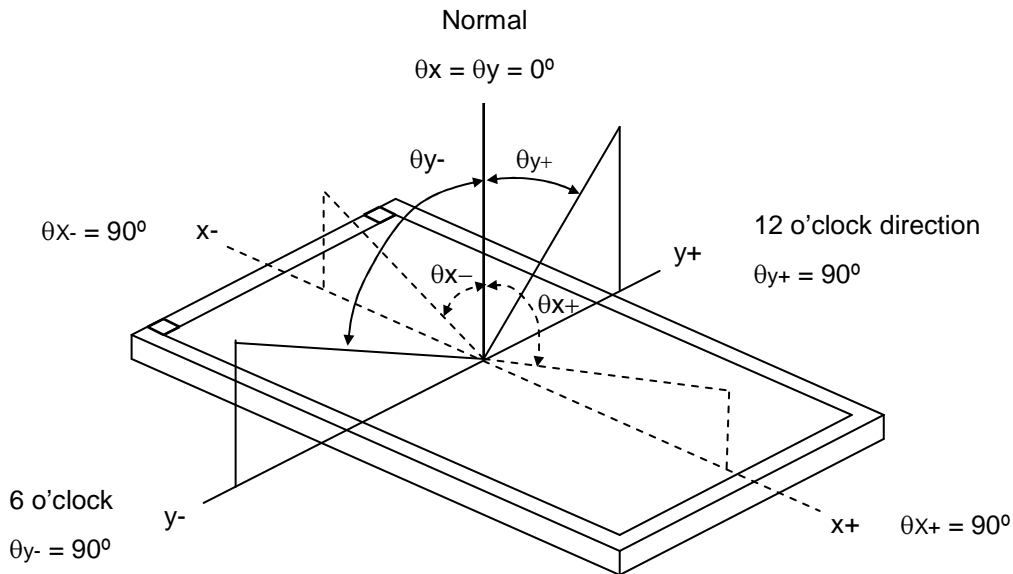

Note (3) Definition of Contrast Ratio (CR):

The contrast ratio can be calculated by the following expression.

$$\text{Contrast Ratio (CR)} = L_{63} / L_0$$

L63: Luminance of gray level 63

L 0: Luminance of gray level 0

$$\text{CR} = \text{CR} (1)$$

CR (X) is corresponding to the Contrast Ratio of the point X at Figure in Note (6).

Note (4) Definition of Response Time (T_R, T_F):

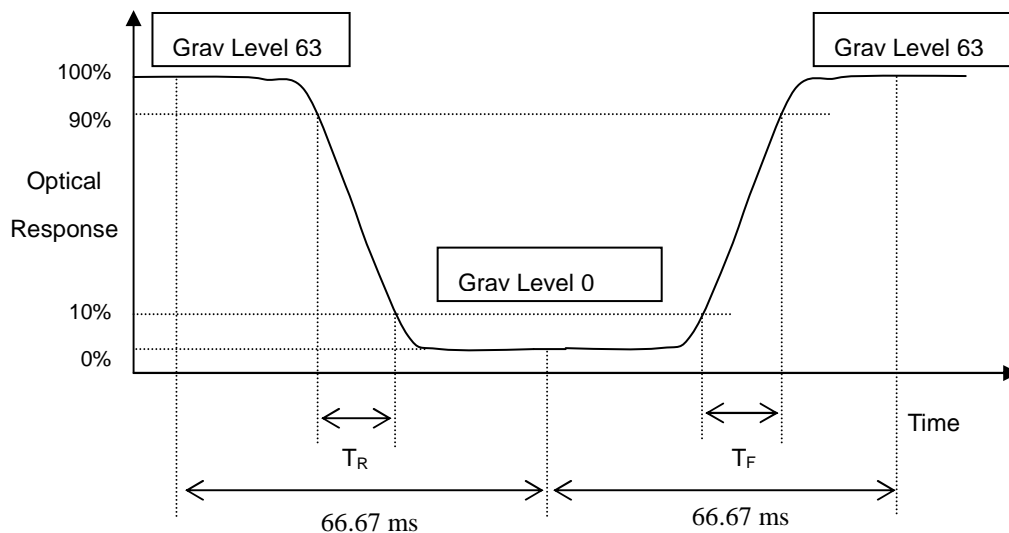

Note (5) Measurement Setup:

The LCD module should be stabilized at given temperature for 20 minutes to avoid abrupt temperature change during measuring. In order to stabilize the luminance, the measurement should be executed after lighting Backlight for 20 minutes in a windless room.

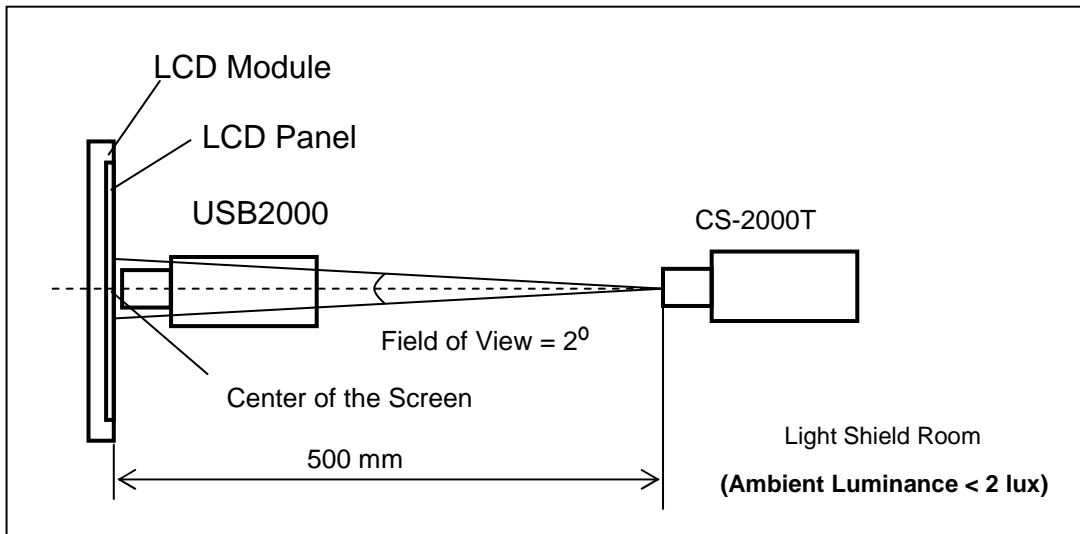

Note (6) Definition of Transmittance Variation ($\delta T\%$):

Measure the transmittance at 13 points

Maximum [T%(1), T%(2), ... T%(13)]

$$\delta T\% = \frac{\text{Maximum [T\%(1), T\%(2), \dots T\%(13)]}}{\text{Minimum [T\%(1), T\%(2), \dots T\%(13)]}}$$

Note (7) Definition of Transmittance (T%):

Module is without signal input.

BLU is supplied by CMI.

$$\text{Transmittance} = \frac{\text{Luminance of LCD module}}{\text{Luminance of backlight}} * 100\%$$

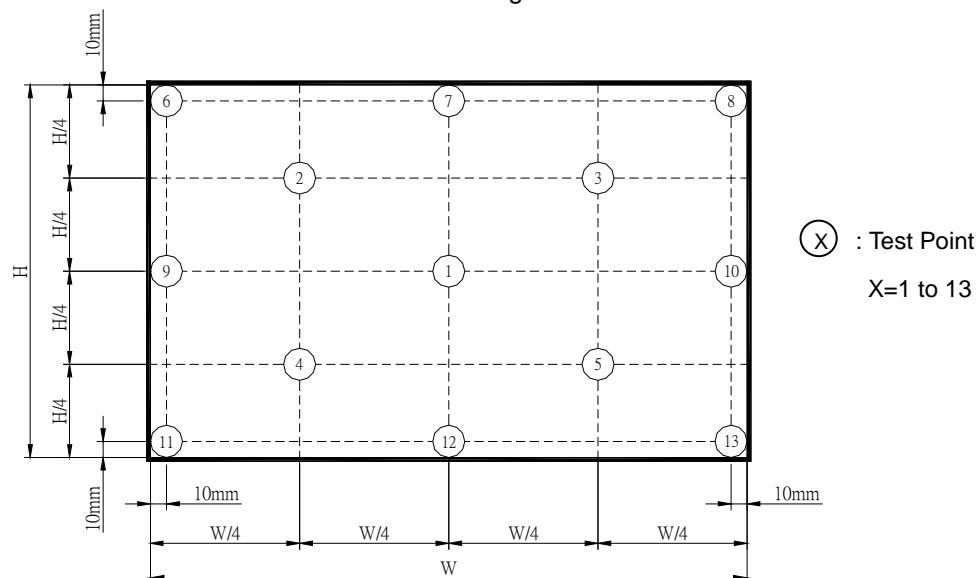

Note (8) The listed optical specifications refer to the initial value of manufacture, but the condition of the specifications after long-term operation will not be warranted.

6. PACKING

6.1 CMI OPEN CELL LABEL

The barcode nameplate is pasted on each OPEN CELL as illustration for CMI internal control.



(a) Model Name: N133HSE - D31

(b) Serial ID: X X X X X X Y M D L N N N N

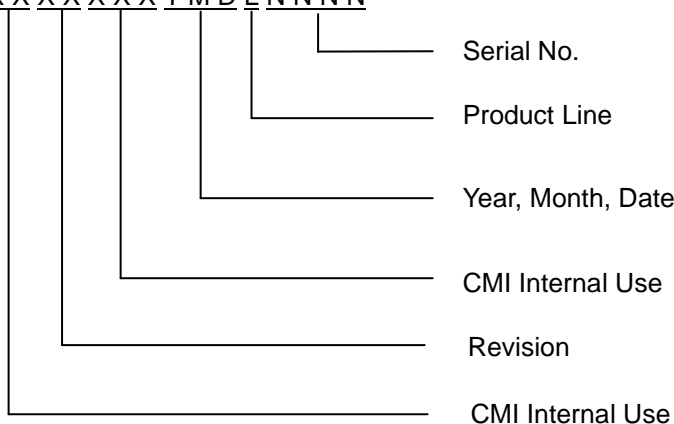

Serial ID includes the information as below:

(a) Manufactured Date: Year: 0~9, for 2010~2019

Month: 1~9, A~C, for Jan. ~ Dec.

Day: 1~9, A~Y, for 1st to 31st, exclude I, O and U

(b) Revision Code: cover all the change

(c) Serial No.: Manufacturing sequence of product

(d) Product Line: 1 -> Line1, 2 -> Line 2, ...etc.

6.2 PACKAGE RELIABILITY

(1) Carton Packing should have no failure in the following reliability test items

Test Item	Test Conditions	Note
Packing Vibration	ISTA STANDARD Random, Frequency Range: 1 – 200 Hz Top & Bottom: 30 minutes (+Z), 10 min (-Z), Right & Left: 10 minutes (X) Back & Forth 10 minutes (Y)	Non Operation

6.3 CARTON

(1) Box Dimensions : 540(L)*450(W)*320(H)
(2) 40 Modules/Carton

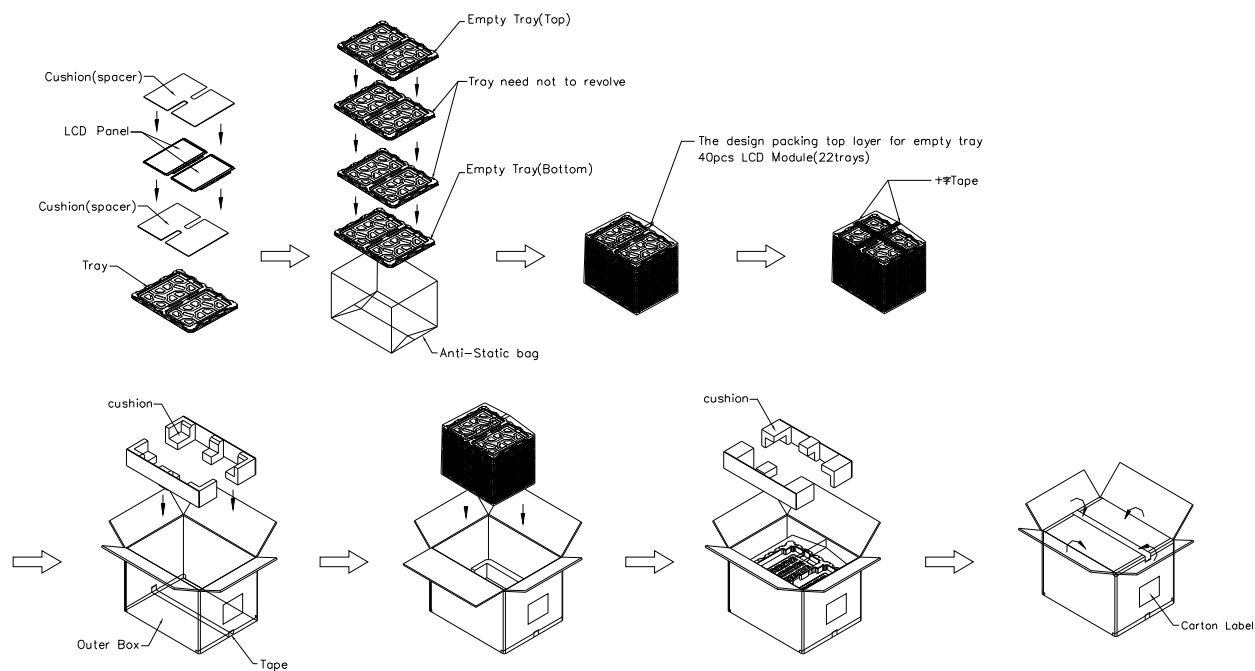

Figure. 6-3 Packing method

6.4 PALLET

Sea & Land Transportation

Air Transportation

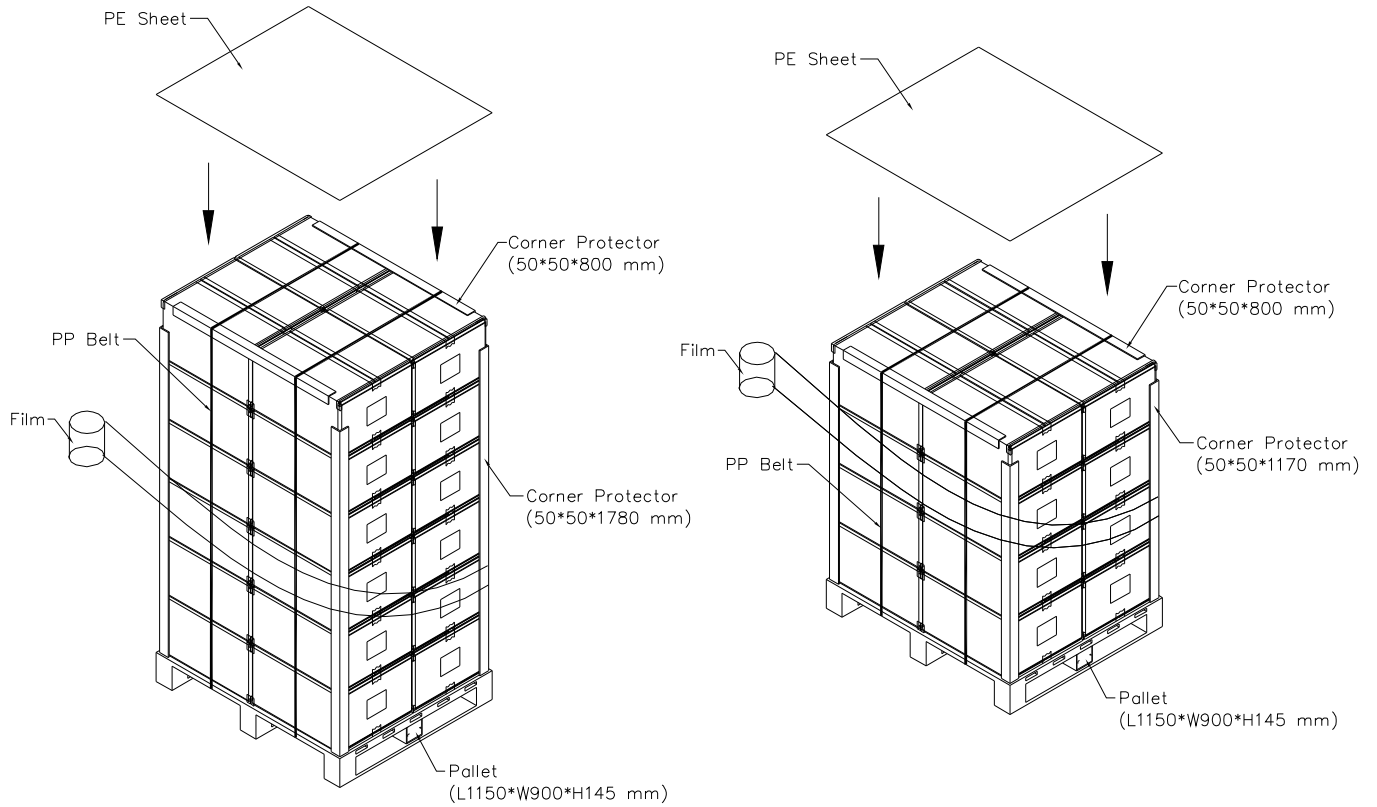

Figure. 6-4 Packing method

7. PRECAUTIONS

7.1 HANDLING PRECAUTIONS

- (1) The open cell should be assembled into the system firmly by using every mounting hole. Be careful not to twist or bend the open cell.
- (2) While assembling or installing open cell, it can only be in the clean area. The dust and oil may cause electrical short or damage the polarizer.
- (3) Use fingerstalls or soft gloves in order to keep display clean during the incoming inspection and assembly process.
- (4) Do not press or scratch the surface harder than a HB pencil lead on the panel because the polarizer is very soft and easily scratched.
- (5) If the surface of the polarizer is dirty, please clean it by some absorbent cotton or soft cloth. Do not use Ketone type materials (ex. Acetone), Ethyl alcohol, Toluene, Ethyl acid or Methyl chloride. It might permanently damage the polarizer due to chemical reaction.
- (6) Wipe off water droplets or oil immediately. Staining and discoloration may occur if they left on panel for a long time.
- (7) If the liquid crystal material leaks from the panel, it should be kept away from the eyes or mouth. In case of contacting with hands, legs or clothes, it must be washed away thoroughly with soap.
- (8) Protect the open cell from static electricity, it may cause damage to the C-MOS Gate Array IC.
- (9) Do not disassemble the open cell.
- (10) Pins of I/F connector should not be touched directly with bare hands.

7.2 STORAGE PRECAUTIONS

- (1) High temperature or humidity may reduce the performance of open cell. Please store open cell within the specified storage conditions.
- (2) It is dangerous that moisture come into or contacted the open cell, because the moisture may damage open cell when it is operating.
- (3) It may reduce the display quality if the ambient temperature is lower than 10 °C. For example, the response time will become slowly.

7.3 OPERATION PRECAUTIONS

- (1) Do not pull the I/F connector in or out while the open cell is operating.
- (2) Always follow the correct power on/off sequence when open cell is connecting and operating. This can prevent the CMOS LSI chips from damage during latch-up.

Appendix. EDID DATA STRUCTURE

The EDID (Extended Display Identification Data) data formats are to support displays as defined in the VESA Plug & Display and FPD standards.

Byte # (decimal)	Byte # (hex)	Field Name and Comments	Value (hex)	Value (binary)
0	0	Header , Fixed	00	00000000
1	1	Header , Fixed	FF	11111111
2	2	Header , Fixed	FF	11111111
3	3	Header , Fixed	FF	11111111
4	4	Header , Fixed	FF	11111111
5	5	Header , Fixed	FF	11111111
6	6	Header , Fixed	FF	11111111
7	7	Header , Fixed	00	00000000
8	8	ID system manufacturer name	0D	00001101
9	9	ID system manufacturer name	AE	10101110
10	0A	ID system Product Code (LSB)	45	01000101
11	0B	ID system Product Code (MSB)	13	00010011
12	0C	32-bit serial # Unused(01h for VESA, 00h for SPWG)	00	00000000
13	0D	32-bit serial # Unused(01h for VESA, 00h for SPWG)	00	00000000
14	0E	32-bit serial # Unused(01h for VESA, 00h for SPWG)	00	00000000
15	0F	32-bit serial # Unused(01h for VESA, 00h for SPWG)	00	00000000
16	10	Week of manufacture 1 - 53 (unused: 00h)	15	00010101
17	11	Year of manufacture year - 1990(unsed:00h)	16	00010110
18	12	Version=1	01	00000001
19	13	Revision=4	04	00000100
20	14	Vedio Input Definition	A5	10100101
21	15	Max H image size ("29.406cm")	1D	00011101
22	16	Max V image size ("16.554cm")	11	00010001
23	17	Display Gamma (Gamma = "2.2")	78	01111000
24	18	Feature support	02	00000010
25	19	Rx1, Rx0, Ry1, Ry0, Gx1, Gx0, Gy1, Gy0	A7	10100111
26	1A	Bx1, Bx0, By1, By0, Wx1, Wx0, Wy1, Wy0	05	00000101
27	1B	Rx=0.65	A6	10100110
28	1C	Ry=0.338	56	01010110
29	1D	Gx=0.329	54	01010100
30	1E	Gy=0.608	9B	10011011
31	1F	Bx=0.148	26	00100110
32	20	By=0.047	0C	00001100
33	21	Wx=0.313	50	01010000
34	22	Wy=0.329	54	01010100
35	23	Established timings 1	00	00000000
36	24	Established timings 2 (1920x1080@40Hz)	00	00000000
37	25	No manufacturer's specific timing	00	00000000
38	26	Standard timing ID # 1	01	00000001
39	27	Standard timing ID # 1	01	00000001
40	28	Standard timing ID # 2	01	00000001
41	29	Standard timing ID # 2	01	00000001

42	2A	Standard timing ID # 3	01	00000001
43	2B	Standard timing ID # 3	01	00000001
44	2C	Standard timing ID # 4	01	00000001
45	2D	Standard timing ID # 4	01	00000001
46	2E	Standard timing ID # 5	01	00000001
47	2F	Standard timing ID # 5	01	00000001
48	30	Standard timing ID # 6	01	00000001
49	31	Standard timing ID # 6	01	00000001
50	32	Standard timing ID # 7	01	00000001
51	33	Standard timing ID # 7	01	00000001
52	34	Standard timing ID # 8	01	00000001
53	35	Standard timing ID # 8	01	00000001
54	36	Detailed timing description # 1 Pixel clock ("138.78MHz", According to VESA CVT Rev1.4)	36	00110110
55	37	# 1 Pixel clock (hex LSB first)	36	00110110
56	38	# 1 H active ("1920")	80	10000000
57	39	# 1 H blank ("160")	A0	10100000
58	3A	# 1 H active : H blank ("1920 :160")	70	01110000
59	3B	# 1 V active ("1080")	38	00111000
60	3C	# 1 V blank ("32")	20	00100000
61	3D	# 1 V active : V blank ("1080 :32")	40	01000000
62	3E	# 1 H sync offset ("46")	2E	00101110
63	3F	# 1 H sync pulse width ("30")	1E	00011110
64	40	# 1 V sync offset : V sync pulse width ("2 : 4")	24	00100100
65	41	# 1 H sync offset : H sync pulse width : V sync offset : V sync width ("46: 30 : 2 : 4")	00	00000000
66	42	# 1 H image size (" 294 mm")	26	00100110
67	43	# 1 V image size ("165 mm")	A5	10100101
68	44	# 1 H image size : V image size ("294 : 165")	10	00010000
69	45	# 1 H boarder ("0")	00	00000000
70	46	# 1 V boarder ("0")	00	00000000
71	47	Non-interlaced, Normal Display, Digital separate, Positive Hsync, Negative Vsync	1A	00011010
72	48	Detailed timing description # 2 Pixel clock ("92.52MHz", According to VESA CVT Rev1.4)	24	00100100
73	49	# 2 Pixel clock (hex LSB first)	24	00100100
74	4A	# 2 H active ("1920")	80	10000000
75	4B	# 2 H blank ("160")	A0	10100000
76	4C	# 2 H active : H blank ("1920 :160")	70	01110000
77	4D	# 2 V active ("1080")	38	00111000
78	4E	# 2 V blank ("32")	20	00100000
79	4F	# 2 V active : V blank ("1080 :32")	40	01000000
80	50	# 2 H sync offset ("46")	2E	00101110
81	51	# 2 H sync pulse width ("30")	1E	00011110
82	52	# 2 V sync offset : V sync pulse width ("2 : 4")	24	00100100
83	53	# 2 H sync offset : H sync pulse width : V sync offset : V sync width ("46: 30 : 2 : 4")	00	00000000
84	54	# 1 H image size ("294 mm")	26	00100110
85	55	# 1 V image size ("165 mm")	A5	10100101

86	56	# 1 H image size : V image size (" 294 : 165")	10	00010000
87	57	# 2 H boarder ("0")	00	00000000
88	58	# 2 V boarder ("0")	00	00000000
89	59	Non-interlaced, Normal Display, Digital separate, Positive Hsync, Negative Vsync	1A	00011010
90	5A	Flag	00	00000000
91	5B	Flag	00	00000000
92	5C	Flag	00	00000000
93	5D	Data Type Tag: Alphanumeric Data String (ASCII)	FE	11111110
94	5E	Flag	00	00000000
95	5F	Dell P/N 1st Character "V"	56	01010110
96	60	Dell P/N 2nd Character "K"	4B	01001011
97	61	Dell P/N 3rd Character "W"	57	01010111
98	62	Dell P/N 4th Character "J"	4A	01001010
99	63	Dell P/N 5th Character "C"	43	01000011
100	64	EDID Revision	80	10000000
101	65	Manufacturer P/N "1"	31	00110001
102	66	Manufacturer P/N "3"	33	00110011
103	67	Manufacturer P/N "3"	33	00110011
104	68	Manufacturer P/N "H"	48	01001000
105	69	Manufacturer P/N "S"	53	01010011
106	6A	Manufacturer P/N "E"	45	01000101
107	6B	Manufacturer P/N (If <13 char, then terminate with ASCII code 0Ah, set remaining char = 20h)	0A	00001010
108	6C	Flag	00	00000000
109	6D	Flag	00	00000000
110	6E	Flag	00	00000000
111	6F	Data Type Tag: Manufacturer Specified Data 00	00	00000000
112	70	Flag	00	00000000
113	71	Color Management	0A	00001010
114	72	Panel Type and Revision	41	01000001
115	73	Frame Rate	31	00110001
116	74	Light Controller Interface and Maximum Luminance	A3	10100011
117	75	Front Surface / Polarizer and Pixel Structure	00	00000000
118	76	Multi-Media Features	10	00010000
119	77	Multi-Media Features	00	00000000
120	78	Special Features	00	00000000
121	79	Special Feature	0A	00001010
122	7A	Special Features	01	00000001
123	7B	(If <13 char, then terminate with ASCII code 0Ah, set remaining char = 20h)	0A	00001010
124	7C	(If <13 char, then terminate with ASCII code 0Ah, set remaining char = 20h)	20	00100000
125	7D	(If <13 char, then terminate with ASCII code 0Ah, set remaining char = 20h)	20	00100000
126	7E	No extension	00	00000000
127	7F	Checksum	23	00100011

Appendix. OUTLINE DRAWING

