



Doc. Number:

- Tentative Specification
- Preliminary Specification
- Approval Specification

**MODEL NO.: N133HSE**  
**SUFFIX: E21**

**Customer:**

**APPROVED BY**

**SIGNATURE**

**Name / Title**

Note

Please return 1 copy for your confirmation with your signature and comments.

Approved By	Checked By	Prepared By

## CONTENTS

<b>1. GENERAL DESCRIPTION .....</b>	<b>4</b>
1.1 OVERVIEW .....	4
1.2 GENERAL SPECIFICATIONS .....	4
<b>2. MECHANICAL SPECIFICATIONS .....</b>	<b>4</b>
2.1 CONNECTOR TYPE .....	4
<b>3. ABSOLUTE MAXIMUM RATINGS .....</b>	<b>5</b>
3.1 ABSOLUTE RATINGS OF ENVIRONMENT .....	5
3.2 ELECTRICAL ABSOLUTE RATINGS .....	5
3.2.1 TFT LCD MODULE .....	5
<b>4. ELECTRICAL SPECIFICATIONS .....</b>	<b>6</b>
4.1 FUNCTION BLOCK DIAGRAM .....	6
4.2. INTERFACE CONNECTIONS .....	6
4.3 ELECTRICAL CHARACTERISTICS .....	8
4.3.1 LCD ELETRONICS SPECIFICATION .....	8
4.3.2 SYSTEM PWM SIGNAL SPECIFICATION .....	10
4.3.3 BACKLIGHT UNIT .....	11
4.4 DISPLAY PORT SIGNAL TIMING SPECIFICATION .....	12
4.4.1 DISPLAY PORT INTERFACE .....	12
4.5 DISPLAY TIMING SPECIFICATIONS .....	13
4.6 POWER ON/OFF SEQUENCE .....	14
<b>5. OPTICAL CHARACTERISTICS .....</b>	<b>16</b>
5.1 TEST CONDITIONS .....	16
5.2 OPTICAL SPECIFICATIONS .....	16
<b>6. RELIABILITY TEST ITEM .....</b>	<b>19</b>
<b>7. PACKING .....</b>	<b>20</b>
7.1 MODULE LABEL .....	20
7.2 CARTON .....	21
7.3 PALLET .....	22
<b>8. PRECAUTIONS .....</b>	<b>23</b>
8.1 HANDLING PRECAUTIONS .....	23
8.2 STORAGE PRECAUTIONS .....	23
8.3 OPERATION PRECAUTIONS .....	23
Appendix. EDID DATA STRUCTURE .....	24
Appendix. OUTLINE DRAWING .....	27
Appendix. SYSTEM COVER DESIGN NOTICE .....	29

REVISION HISTORY

Version	Date	Page	Description
2.0	Oct.1, 2012	All	Approval spec. ver. 2.0 was first issued.

深圳市诚易盛电子TEL：18818991580 QQ:474684179

## 1. GENERAL DESCRIPTION

### 1.1 OVERVIEW

N133HSE – E21 is a 13.3" TFT Liquid Crystal Display module with LED Backlight unit and 30 pins eDP interface. This module supports 1920 x 1080 FHD mode and can display 16,777,216 colors. The optimum viewing angle is at 6 o'clock direction.

### 1.2 GENERAL SPECIFICATIONS

Item	Specification	Unit	Note
Screen Size	13.3 diagonal		
Driver Element	a-si TFT active matrix	-	-
Pixel Number	1920 x R.G.B. x 1080	pixel	-
Pixel Pitch	0.1529 (H) x 0.1529 (V)	mm	-
Pixel Arrangement	RGB vertical stripe	-	-
Display Colors	16,777,216	color	-
Transmissive Mode	Normally black	-	-
Surface Treatment	Hard coating (3H), Anti-Glare	-	-
Luminance, White	350	Cd/m2	
Backlight Unit	LEDs 9 strings x 6 parallel		
RoHs Compliance	Yes		
Power Consumption	Total 4.93 W(Max.) @ cell 1.01W(Max.), BL 3.92 W(Max.)		(1)

Note (1) The specified power consumption (with converter efficiency) is under the conditions at VCCS = 3.3 V, fv = 60 Hz, LED\_VCCS = Typ, fPWM = 200 Hz, Duty=100% and Ta = 25 ± 2 °C, whereas mosaic pattern is displayed.

## 2. MECHANICAL SPECIFICATIONS

Item	Min.	Typ.	Max.	Unit	Note	
Module Size	Horizontal (H)	304.85	305.35	305.85	mm	(1)
	Vertical (V) (W/ PCBA)	178.06	178.56	179.06	mm	
	Thickness (T)	NA	2.7	2.85	mm	
	Thickness (T) (Top)	NA	5	5.2		
	Thickness (T) (W/ TAPE)	NA	2.7	2.85		
Active Area	Horizontal	293.66	293.76	293.86	mm	
	Vertical	165.14	165.24	165.34	mm	
Weight	-	240	255	g		

Note (1) Please refer to the attached drawings for more information of front and back outline dimensions.

### 2.1 CONNECTOR TYPE

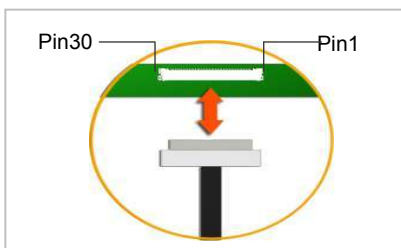

Please refer Appendix Outline Drawing for detail design.

Connector Part No.: IPEX-20455-030E-12

User's connector Part No: IPEX-20453-030T-01 or equivalent

### 3. ABSOLUTE MAXIMUM RATINGS

#### 3.1 ABSOLUTE RATINGS OF ENVIRONMENT

Item	Symbol	Value		Unit	Note
		Min.	Max.		
Storage Temperature	T <sub>ST</sub>	-20	+70	°C	(1)
Operating Ambient Temperature	T <sub>OP</sub>	-10	+60	°C	(1), (2)

Note (1) (a) 90 %RH Max. (Ta <= 40 °C).

(b) Wet-bulb temperature should be 39 °C Max. (Ta > 40 °C).

(c) No condensation.

Note (2) The temperature of panel surface should be -10 °C min. and 70 °C max.

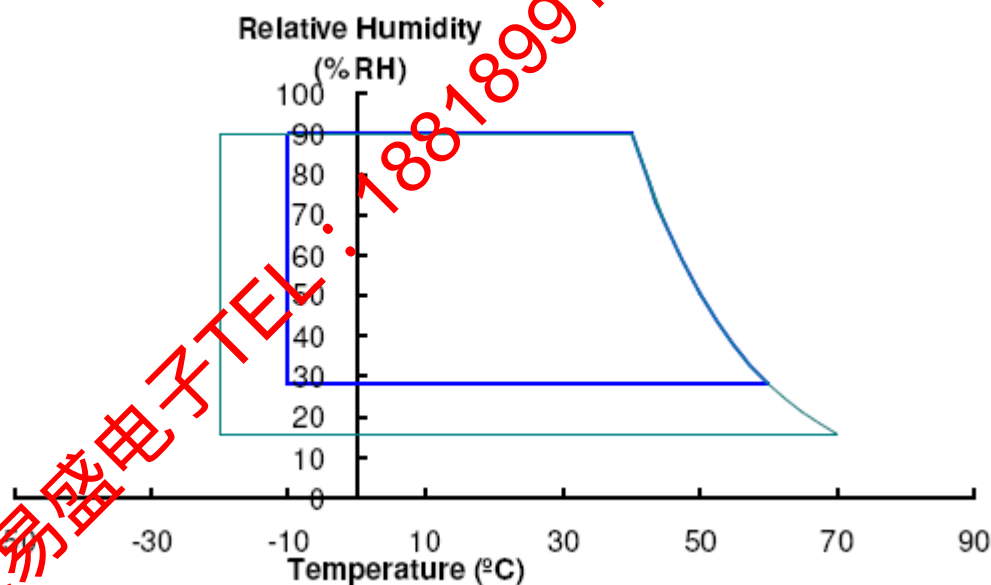

#### 3.2 ELECTRICAL ABSOLUTE RATINGS

##### 3.2.1 TFT LCD MODULE

Item	Symbol	Value		Unit	Note
		Min.	Max.		
Power Supply Voltage	VCCS	-0.3	+4.0	V	(1)
Logic Input Voltage	V <sub>IN</sub>	-0.3	VCCS+0.3	V	
System PWM Signal Voltage	PWM_IN	-0.3	+3.6	V	

Note (1) Stresses beyond those listed in above “ELECTRICAL ABSOLUTE RATINGS” may cause permanent damage to the device. Normal operation should be restricted to the conditions described in “ELECTRICAL CHARACTERISTICS”.

## 4. ELECTRICAL SPECIFICATIONS

### 4.1 FUNCTION BLOCK DIAGRAM

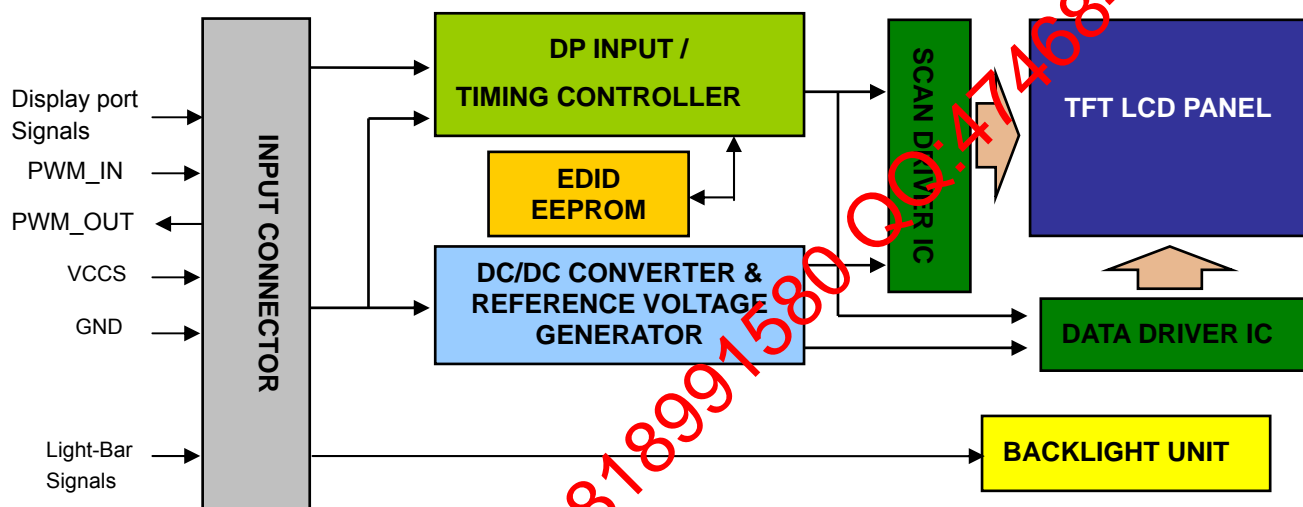

### 4.2. INTERFACE CONNECTIONS

#### PIN ASSIGNMENT

Pin	Symbol	Description	Remark
1	Panel_ID0	Panel_ID0 (NC for N133HSE-E21)	
2	H_GND	High Speed Ground	
3	ML-	Complement Signal-Lane 0	
4	ML1+	True Signal-Main Lane 0	
5	H_GND	High Speed Ground	
6	ML0-	Complement Signal-Lane 0	
7	ML0+	True Signal-Main Lane 0	
8	H_GND	High Speed Ground	
9	AUX+	True Signal-Auxiliary Channel	
10	AUX-	Complement Signal-Auxiliary Channel	
11	H_GND	High Speed Ground	
12	VCCS	Power Supply +3.3 V (typical)	
13	VCCS	Power Supply +3.3 V (typical)	
14	NC	No Connection (Reserved for CMI test)	
15	GND	Ground	
16	GND	Ground	
17	HPD	Hot Plug Detect	
18	PWM_IN	System PWM signal input	
19	PWM_OUT	Panel PWM signal output to system	
20	Cathode1	LED Cathode	
21	Cathode2	LED Cathode	
22	Cathode3	LED Cathode	
23	Cathode4	LED Cathode	
24	Cathode5	LED Cathode	

25	Cathode6	LED Cathode	
26	NC	No Connection	
27	NC	No Connection	
28	Anode	LED Anode	
29	Anode	LED Anode	
30	Panel_ID1	Panel_ID1 (NC for N133HSE-E21)	

Note (1) The first pixel is odd as shown in the following figure.

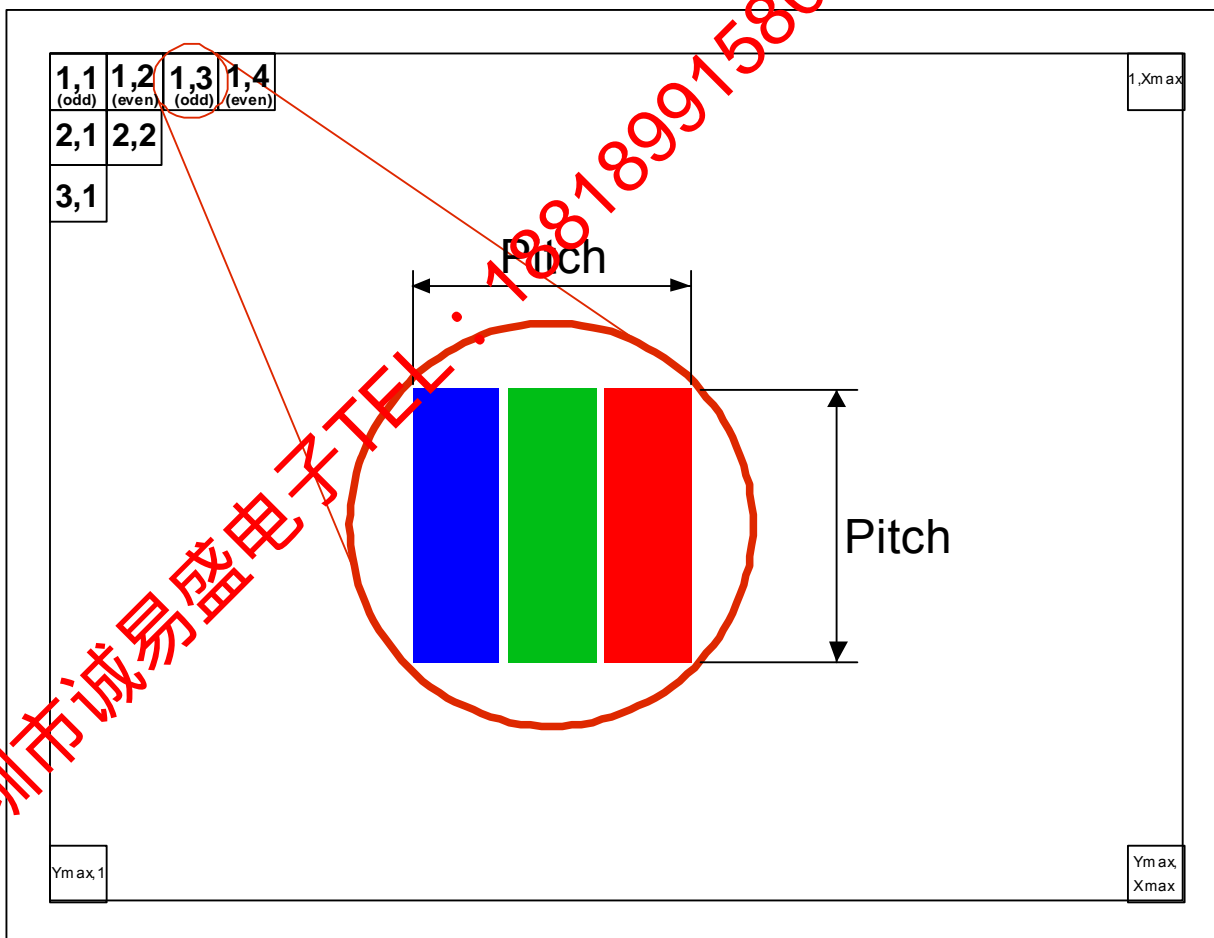

### 4.3 ELECTRICAL CHARACTERISTICS

#### 4.3.1 LCD ELETRONICS SPECIFICATION

Parameter		Symbol	Value			Unit	Note
			Min.	Typ.	Max.		
Power Supply Voltage		VCCS	3.0	3.3	3.6	V	(1)-
HPD	High Level		3.0	-	3.6	V	
	Low Level		0	-	0.4	V	
Ripple Voltage		$V_{RP}$	-	50	-	mV	(1)-
Inrush Current		$I_{RUSH}$	-	-	1.5	A	(1),(2)
Power Supply Current	Mosaic	$I_{CC}$		275	305	mA	(3)a
	White			315	350	mA	(3)b

Note (1) The ambient temperature is  $T_a = 25 \pm 2^\circ C$ .

Note (2)  $I_{RUSH}$ : the maximum current when VCCS is rising

$I_{IS}$ : the maximum current of the first 100ms after power-on

Measurement Conditions: Shown as the following figure. Test pattern: black.

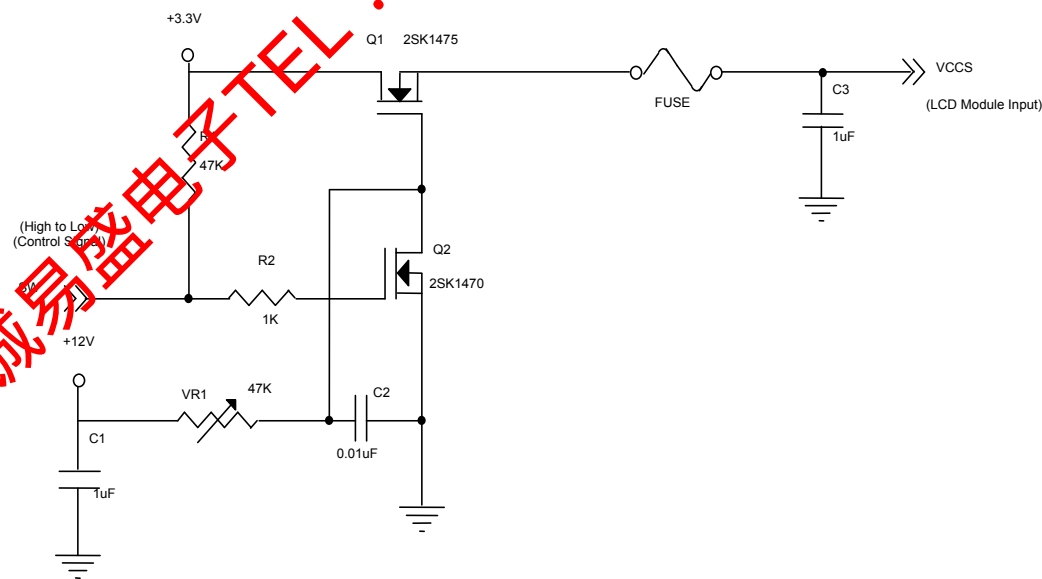

**VCCS rising time is 0.5ms**

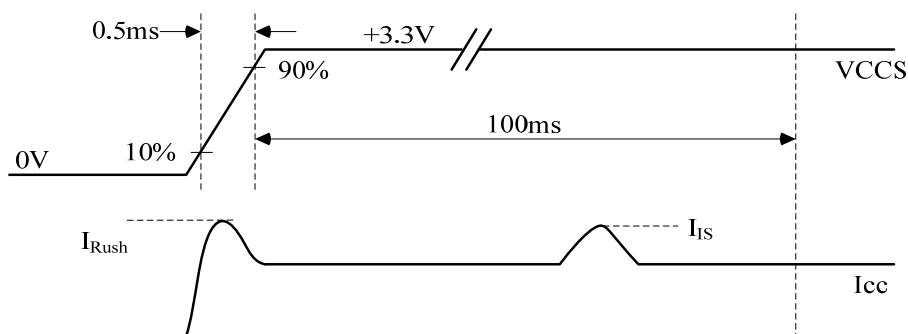



Note (3) The specified power supply current is under the conditions at  $V_{CCS} = 3.3\text{ V}$ ,  $T_a = 25 \pm 2^\circ\text{C}$ , DC Current and  $f_v = 60\text{ Hz}$ , whereas a power dissipation check pattern below is displayed.

a. Mosaic Pattern

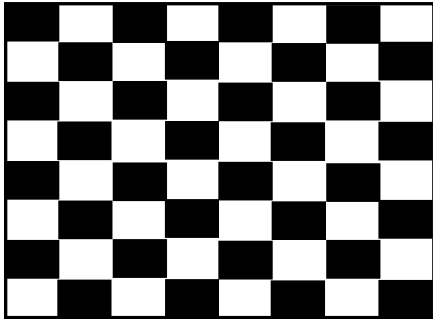

Active Area

b. White Pattern

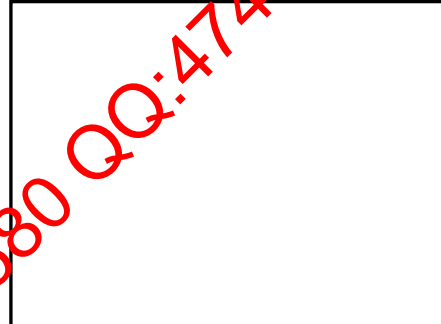

Active Area

深圳市诚易盛电子TEL：18818991580 QQ:474684179

4.3.2 SYSTEM PWM SIGNAL SPECIFICATION

Parameter		Symbol	Value			Unit	Note
			Min.	Typ.	Max.		
PWM Control Level	PWM High Level		3.0	-	3.6	V	
	PWM Low Level		0	-	0.5	V	
PWM Control Duty Ratio			5	-	100	%	(1)
PWM Control Permissive Ripple Voltage		VPWM_pp	-	-	100	mV	
PWM Control Frequency		f <sub>PWM</sub>	100	-	2K	Hz	(2)

Note (1) If the PWM control duty ratio is less than 10%, there is some possibility that acoustic noise or backlight flash can be found. And it is also difficult to control the brightness linearity.

Note (2) If PWM control frequency is applied in the range less than 1KHz, the “waterfall” phenomenon on the screen may be found. To avoid the issue, it’s a suggestion that PWM control frequency should follow the criterion as below.

PWM control frequency f<sub>PWM</sub> should be in the range

$$(N + 0.33) * f \leq f_{PWM} \leq (N + 0.66) * f$$

N : Integer (N ≥ 3)

f : Frame rate

深圳市诚易盛电子 TEL: 188718991580 QQ: 474684179

4.3.3 BACKLIGHT UNIT

Ta = 25 ± 2 °C

Parameter	Symbol	Value			Unit	Note
		Min.	Typ.	Max.		
LED Light Bar Power Supply Voltage	V <sub>L</sub>	25.2	27	29.7	V	(1)(2) (Duty100%)
LED Light Bar Power Supply Current	I <sub>L</sub>	132			mA	
Power Consumption	P <sub>L</sub>		3.564	3.9204	W	(3)
LED Life Time	L <sub>BL</sub>	12,000	-		Hrs	(4)

Note (1) LED current is measured by utilizing a high frequency current meter as shown below :

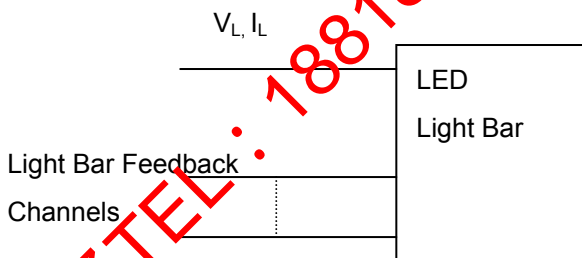

Note (2) For better LED light bar driving quality, it is recommended to utilize the adaptive boost converter with current balancing function to drive LED light-bar.

Note (3)  $P_L = I_L \times V_L$  (Without LED converter transfer efficiency)

Note (4) The lifetime of LED is defined as the time when it continues to operate under the conditions at Ta = 25 ± 2 °C and I<sub>L</sub> = 20 mA(Per EA) until the brightness becomes ≤ 50% of its original value.

#### 4.4 DISPLAY PORT SIGNAL TIMING SPECIFICATION

##### 4.4.1 DISPLAY PORT INTERFACE

Parameter	Symbol	Min.	Typ.	Max.	Unit	Notes
Differential Signal Common Mode Voltage(MainLink and AUX)	V <sub>CM</sub>	0			V	(1)(3)
AUX AC Coupling Capacitor	C <sub>AUX</sub>	75		200	nF	(2)

Note (1) Display port interface related AC coupled signals should follow VESA DisplayPort Standard Version1. Revision 1a and VESA Embedded DisplayPort™ Standard Version 1.1.

(2) The AUX AC Coupling Capacitor should be placed on Source Devices.

(3)The source device should pass the test criteria described in DisplayPortCompliance Test Specification (CTS) 1.1

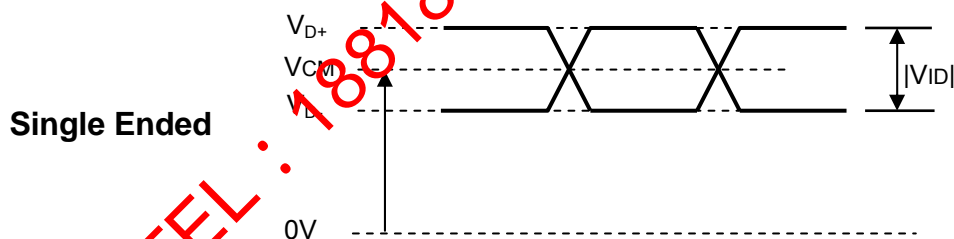

深圳市诚易盛电子TEL: 18818991500

#### 4.5 DISPLAY TIMING SPECIFICATIONS

The input signal timing specifications are shown as the following table and timing diagram.

Signal	Item	Symbol	Min.	Typ.	Max.	Unit	Note
DCLK	Frequency	1/Tc	87.9	138.5	146.4	MHz	-
DE	Vertical Total Time	TV	1104	1112	1120	TH	-
	Vertical Active Display Period	TVD	1080	1080	1080	TH	-
	Vertical Active Blanking Period	TVB	TV-TVD	32	TV-TVD	TH	-
	Horizontal Total Time	TH	2040	2080	2120	Tc	-
	Horizontal Active Display Period	THD	1920	1920	1920	Tc	-
	Horizontal Active Blanking Period	THB	TH-THD	160	TH-THD	Tc	-

**DISPLAY SIGNAL TIMING DIAGRAM**

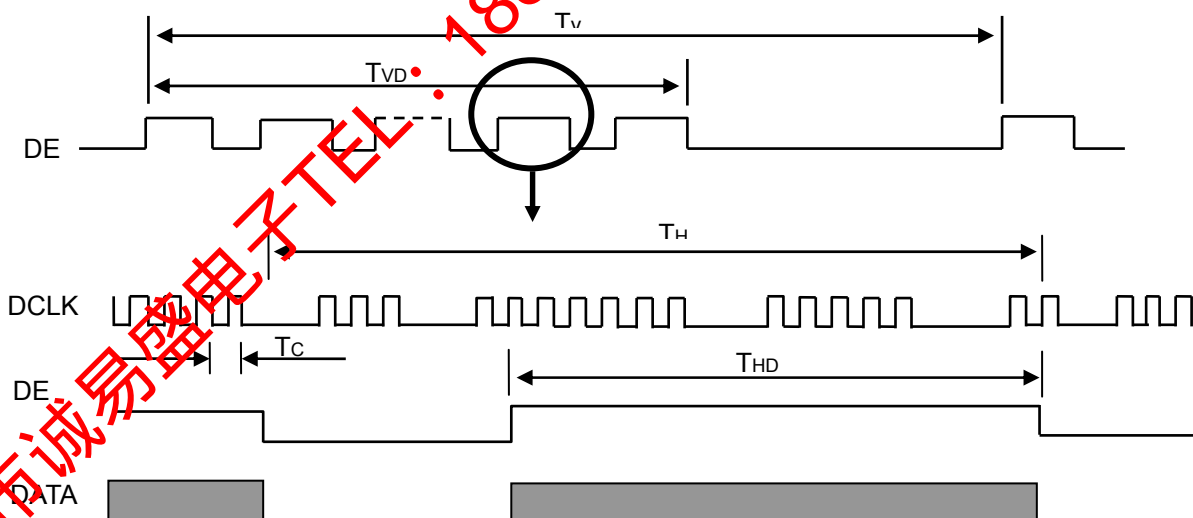

4.6 POWER ON/OFF SEQUENCE

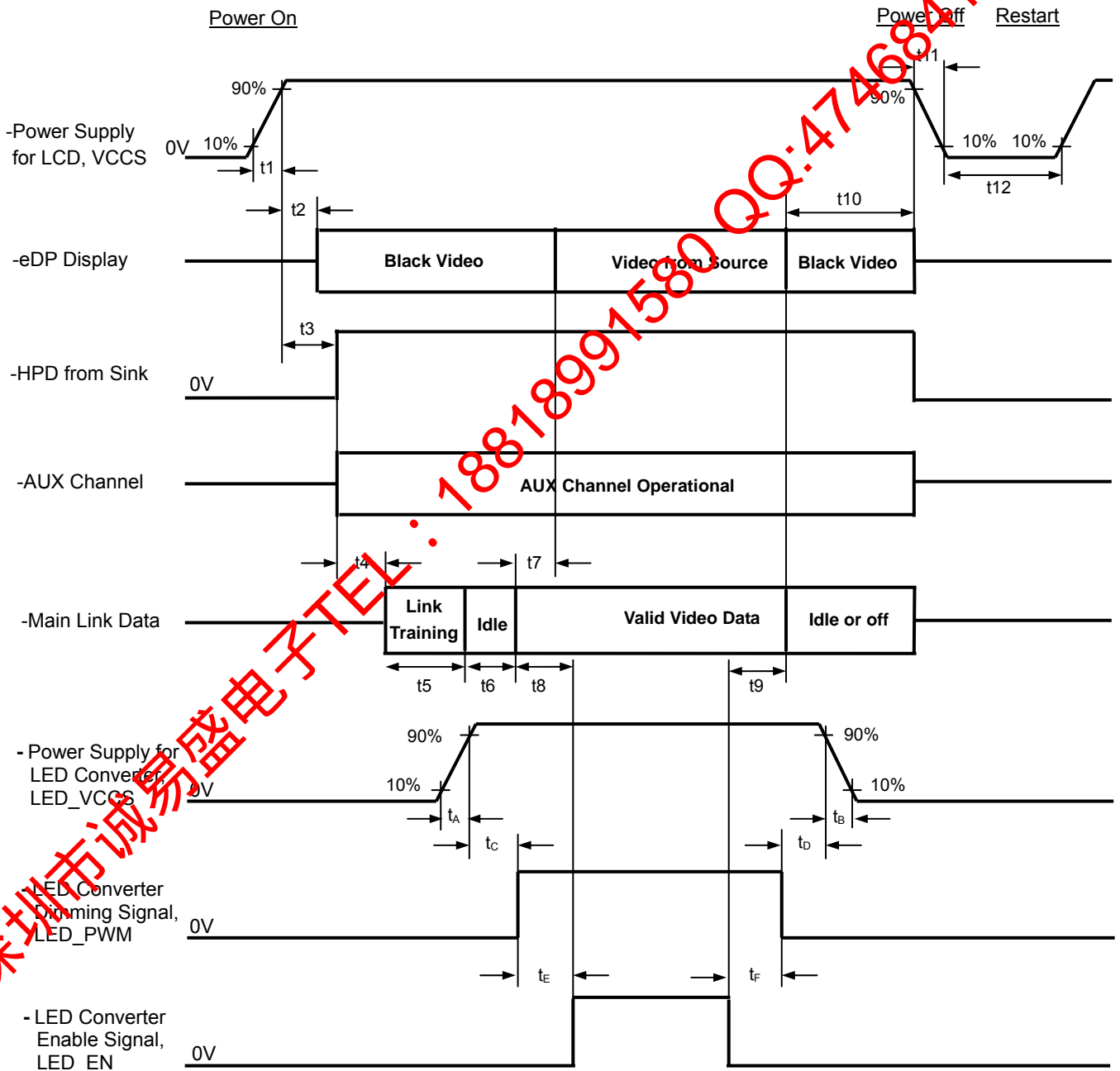

Timing Specifications: Follow VESA Embedded Display Port Standard Version 1

Parameter	Description	Reqd. By	Value		Unit	Notes
			Min	Max		
t1	Power rail rise time, 10% to 90%	Source	0.5	10	ms	-
t2	Delay from LCD,VCCS to black video generation	Sink	0	200	ms	-
t3	Delay from LCD,VCCS to HPD high	Sink	0	200	ms	-
t4	Delay from HPD high to link training initialization	Source	-	-	ms	-
t5	Link training duration	Source	-	-	ms	-
t6	Link idle	Source	-	-	ms	-
t7	Delay from valid video data from Source to video on display	Sink	0	50	ms	-
t8	Delay from valid video data from Source to backlight on	Source	-	-	ms	-
t9	Delay from backlight off to end of valid video data	Source	-	-	ms	-
t10	Delay from end of valid video data from Source to power off	Source	0	500	ms	-
t11	VCCS power rail fall time, 90% to 10%	Source	0.5	10	ms	-
t12	VCCS Power off time	Source	500	-	ms	-
t <sub>A</sub>	LED power rail rise time, 10% to 90%	Source	0.5	10	ms	-
t <sub>B</sub>	LED power rail fall time, 90% to 10%	Source	0	10	ms	-
t <sub>C</sub>	Delay from LED power rising to LED dimming signal	Source	10	-	ms	-
t <sub>D</sub>	Delay from LED dimming signal to LED power falling	Source	10	-	ms	-
t <sub>E</sub>	Delay from LED dimming signal to LED enable signal	Source	10	-	ms	-
t <sub>F</sub>	Delay from LED enable signal to LED dimming signal	Source	10	-	ms	-

Note (1) Please don't plug or unplug the interface cable when system is turned on.

Note (2) Please avoid floating state of the interface signal during signal invalid period.

Note (3) It is recommended that the backlight power must be turned on after the power supply for LCD and the interface signal is valid.

5. OPTICAL CHARACTERISTICS

5.1 TEST CONDITIONS

Item	Symbol	Value	Unit
Ambient Temperature	Ta	25±2	°C
Ambient Humidity	Ha	50±10	%RH
Supply Voltage	V <sub>CC</sub>	3.3	V
Input Signal	According to typical value in "3. ELECTRICAL CHARACTERISTICS"		
LED Light Bar Input Current	I <sub>L</sub>	122	mA

The measurement methods of optical characteristics are shown in Section 5.2. The following items should be measured under the test conditions described in Section 5.1 and stable environment shown in Note (5).

5.2 OPTICAL SPECIFICATIONS

Item	Symbol	Condition	Min.	Typ.	Max.	Unit	Note	
Contrast Ratio	CR	θ <sub>x</sub> =0°, θ <sub>y</sub> =0° Viewing Normal Angle	500	700	-	-	(2), (5), (7)	
Response Time	T <sub>R</sub>		-	14	19	ms	(3), (7)	
	T <sub>F</sub>		-	11	16	ms		
Average Luminance of White	L <sub>Ave</sub>		295	350	-	cd/m <sup>2</sup>	(4), (6), (7)	
Color Chromaticity	Red		R <sub>x</sub>	Typ - 0.03	0.650	Typ + 0.03	-	(1), (7)
			R <sub>y</sub>		0.338		-	
	Green		G <sub>x</sub>		0.329		-	
			G <sub>y</sub>		0.608		-	
	Blue		B <sub>x</sub>		0.148		-	
			B <sub>y</sub>		0.047		-	
	White	W <sub>x</sub>	0.313		-			
		W <sub>y</sub>	0.329		-			
Viewing Angle	Horizontal	θ <sub>x+</sub>	80	89	-	Deg.	(1), (5), (7)	
		θ <sub>x-</sub>	80	89	-			
	Vertical	θ <sub>y+</sub>	80	89	-			
		θ <sub>y-</sub>	80	89	-			
White Variation of 5 Points	δW <sub>5p</sub>	θ <sub>x</sub> =0°, θ <sub>y</sub> =0°	70	80	-	%	(5), (6),	

Note (1) Definition of Viewing Angle (θ<sub>x</sub>, θ<sub>y</sub>)

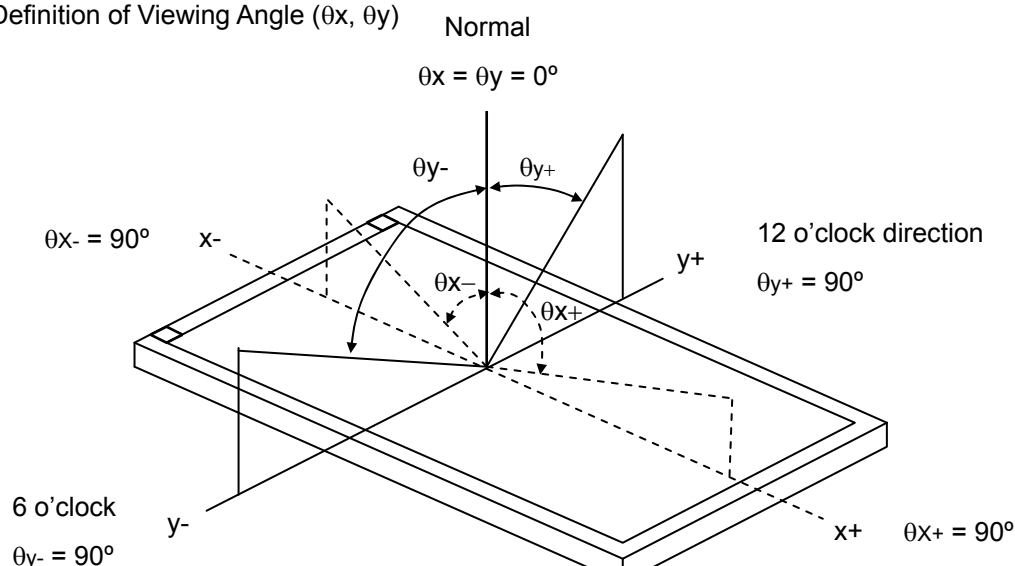



Note (2) Definition of Contrast Ratio (CR):

The contrast ratio can be calculated by the following expression.

$$\text{Contrast Ratio (CR)} = L_{63} / L_0$$

L63: Luminance of gray level 63

L 0: Luminance of gray level 0

$$\text{CR} = \text{CR} (1)$$

CR (X) is corresponding to the Contrast Ratio of the point X at Figure in Note (6).

Note (3) Definition of Response Time ( $T_R$ ,  $T_F$ ):

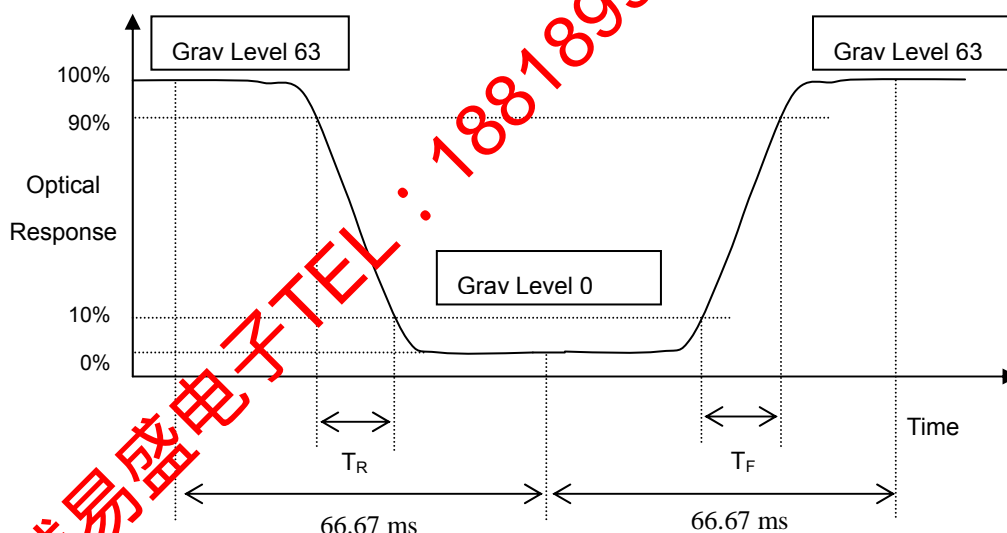

Note (4) Definition of Average Luminance of White ( $L_{AVE}$ ):

Measure the luminance of gray level 63 at 5 points

$$L_{AVE} = [L (1)+ L (2)+ L (3)+ L (4)+ L (5)] / 5$$

L (x) is corresponding to the luminance of the point X at Figure in Note (6)

Note (5) Measurement Setup:

The LCD module should be stabilized at given temperature for 20 minutes to avoid abrupt temperature change during measuring. In order to stabilize the luminance, the measurement should be executed after lighting Backlight for 20 minutes in a windless room.

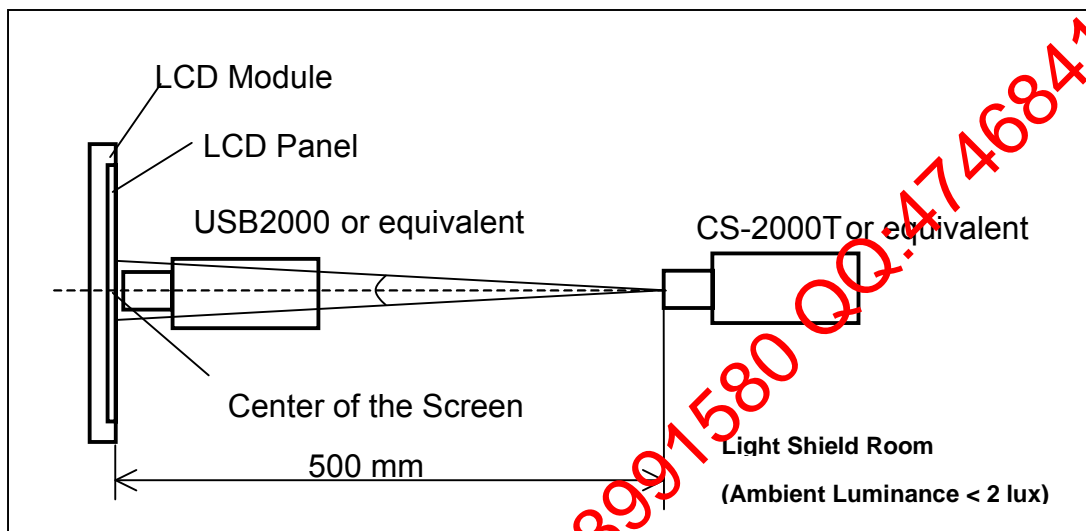

Note (6) Definition of White Variation ( $\delta W$ )

Measure the luminance of gray level 63 at 5 points

$$\delta W_{5p} = \{ \text{Minimum} [L(1) \sim L(5)] / \text{Maximum} [L(1) \sim L(5)] \} * 100\%$$

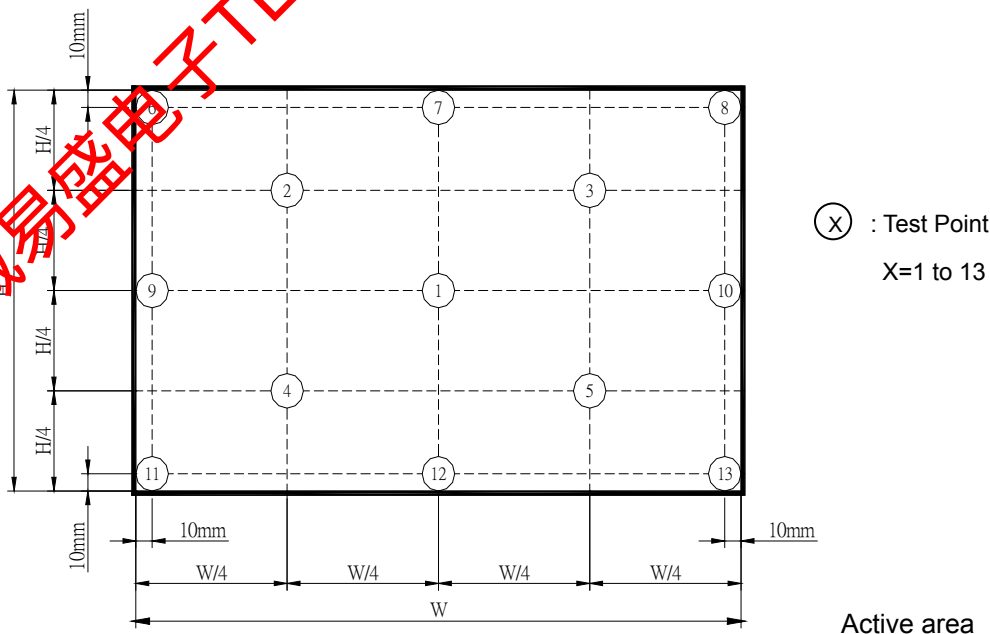

Note (7) The listed optical specifications refer to the initial value of manufacture, but the condition of the specifications after long-term operation will not be warranted.

6. RELIABILITY TEST ITEM

Test Item	Test Condition	Note
High Temperature Storage Test	70°C, 240 hours	(1) (2)
Low Temperature Storage Test	-20°C, 240 hours	
Thermal Shock Storage Test	-20°C, 0.5hour←→70°C, 0.5hour; 100cycles, 1hour/cycle	
High Temperature Operation Test	60°C, 240 hours	
Low Temperature Operation Test	-10°C, 240 hours	
High Temperature & High Humidity Operation Test	60°C, RH 90%, 240hours	
ESD Test (Operation)	150pF, 330Ω, 1ns/cycle Condition 1: Contact Discharge, ±8KV Condition 2: Air Discharge, ±15KV	(1)
Shock (Non-Operating)	220G, 2ms, half sine wave, 1 time for each direction of ±X, ±Y, ±Z	(1)(3)
Vibration (Non-Operating)	1.5G / 10-500 Hz, Sine wave, 30 min/cycle, 1cycle for each X, Y, Z	(1)(3)

Note (1) criteria : Normal display image with no obvious non-uniformity and no line defect.

Note (2) Evaluation should be tested after storage at room temperature for more than two hour

Note (3) At testing, Vibration and Shock, the fixture in holding the module has to be hard and rigid enough so that the module would not be twisted or bent by the fixture.

7. PACKING

7.1 MODULE LABEL

The barcode nameplate is pasted on each module as illustration, and its definitions are as following explanation.



- (a) Model Name: N133HSE – E21
- (b) Revision: Rev. XX, for example: C1, C2 ...etc.
- (c) Serial ID: XXXXXXYMDLNNNN

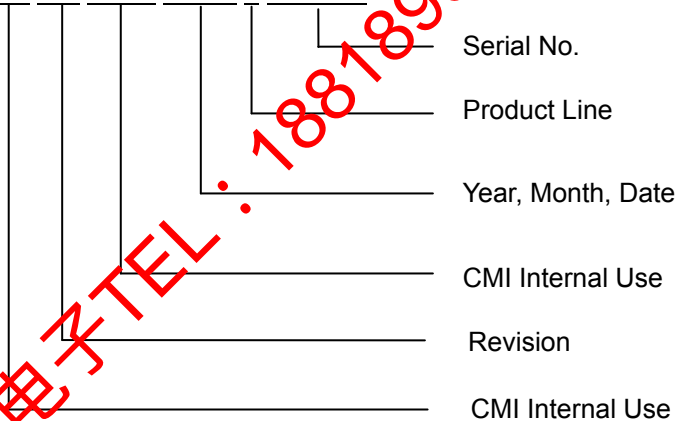

Serial ID includes the information as below:

- (a) Manufactured Date: Year: 0~9, for 2010~2019  
 Month: 1~9, A~C, for Jan. ~ Dec.  
 Day: 1~9, A~Y, for 1<sup>st</sup> to 31<sup>st</sup>, exclude I, O and U
- (b) Revision Code: cover all the change
- (c) Serial No.: Manufacturing sequence of product
- (d) Product Line: 1 -> Line1, 2 -> Line 2, ...etc.
- (e) UL logo: "XXXX" is factory ID

深圳市诚易盛电子 TEL: 18818991580 QQ: 474684179

### 7.2 CARTON

Box Dimensions : 540(L)\*450(W)\*320(H)  
Weight : Approx. 16.62 Kg (40 module .per. 1box)

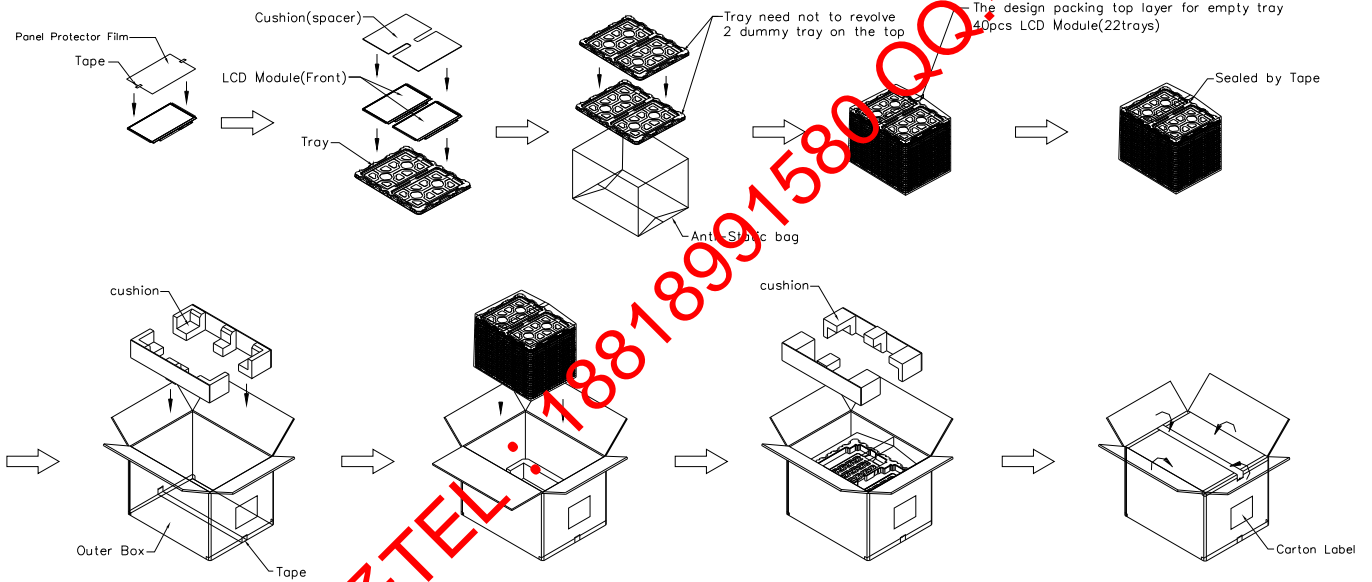

深圳市诚易盛电子 TEL: 78878991580 QQ: 474684179

### 7.3 PALLET

Sea & Land Transportation

Air Transportation

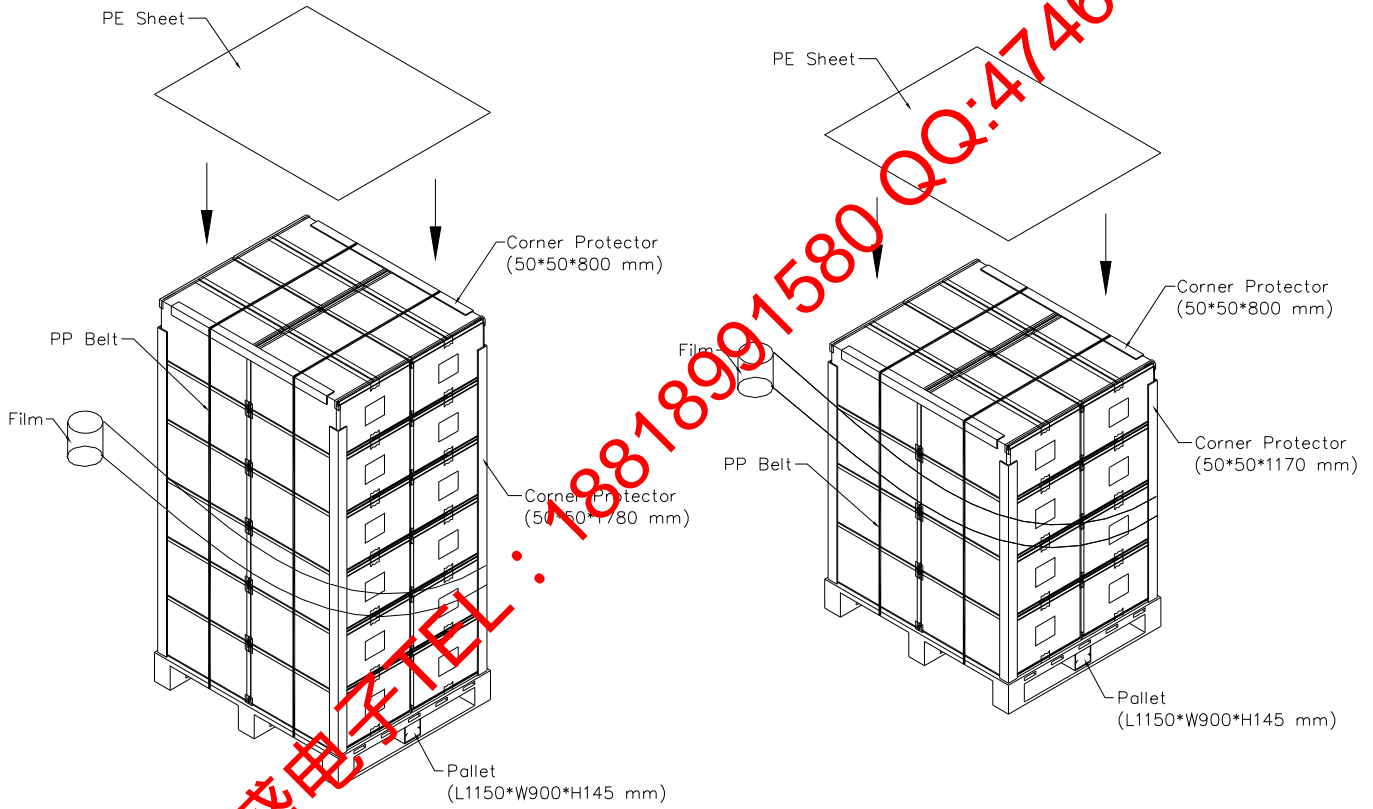

## 8. PRECAUTIONS

### 8.1 HANDLING PRECAUTIONS

- (1) The module should be assembled into the system firmly by using every mounting hole. Be careful not to twist or bend the module.
- (2) While assembling or installing modules, it can only be in the clean area. The dust and oil may cause electrical short or damage the polarizer.
- (3) Use fingerstalls or soft gloves in order to keep display clean during the incoming inspection and assembly process.
- (4) Do not press or scratch the surface harder than a HB pencil lead on the panel because the polarizer is very soft and easily scratched.
- (5) If the surface of the polarizer is dirty, please clean it by some absorbent cotton or soft cloth. Do not use Ketone type materials (ex. Acetone), Ethyl alcohol, Toluene, Ethyl acid or Methyl chloride. It might permanently damage the polarizer due to chemical reaction.
- (6) Wipe off water droplets or oil immediately. Staining and discoloration may occur if they left on panel for a long time.
- (7) If the liquid crystal material leaks from the panel, it should be kept away from the eyes or mouth. In case of contacting with hands, legs or clothes, it must be washed away thoroughly with soap.
- (8) Protect the module from static electricity, it may cause damage to the C-MOS Gate Array IC.
- (9) Do not disassemble the module.
- (10) Do not pull or fold the LED wire.
- (11) Pins of I/F connector should not be touched directly with bare hands.

### 8.2 STORAGE PRECAUTIONS

- (1) High temperature or humidity may reduce the performance of module. Please store LCD module within the specified storage conditions.
- (2) It is dangerous that moisture come into or contacted the LCD module, because the moisture may damage LCD module when it is operating.
- (3) It may reduce the display quality if the ambient temperature is lower than 10 °C. For example, the response time will become slowly, and the starting voltage of LED will be higher than the room temperature.

### 8.3 OPERATION PRECAUTIONS

- (1) Do not pull the I/F connector in or out while the module is operating.
- (2) Always follow the correct power on/off sequence when LCD module is connecting and operating. This can prevent the CMOS LSI chips from damage during latch-up.
- (3) The startup voltage of Backlight is approximately 1000 Volts. It may cause electrical shock while assembling with converter. Do not disassemble the module or insert anything into the Backlight unit.

**Appendix. EDID DATA STRUCTURE**

The EDID (Extended Display Identification Data) data formats are to support displays as defined in the VESA Plug & Display and FPD1 standards.

Byte # (decimal)	Byte # (hex)	Field Name and Comments	Value (hex)	Value (binary)
0	0	Header	00	00000000
1	1	Header	FF	11111111
2	2	Header	FF	11111111
3	3	Header	FF	11111111
4	4	Header	FF	11111111
5	5	Header	FF	11111111
6	6	Header	FF	11111111
7	7	Header	00	00000000
8	8	EISA ID manufacturer name ("CM")	0D	00001101
9	9	EISA ID manufacturer name (Compressed ASCII)	AE	10101110
10	0A	ID product code (N133HSE-E2)	49	01001001
11	0B	ID product code (hex LSB first; N133HSE-E21)	13	00010011
12	0C	ID S/N (fixed "0")	00	00000000
13	0D	ID S/N (fixed "0")	00	00000000
14	0E	ID S/N (fixed "0")	00	00000000
15	0F	ID S/N (fixed "0")	00	00000000
16	10	Week of manufacture (fixed week code)	28	00101000
17	11	Year of manufacture (fixed year code)	16	00010110
18	12	EDID structure version # ("1")	01	00000001
19	13	EDID revision # ("4")	04	00000100
20	14	Audio Input Definition	A5	10100101
21	15	Max H image size ("28.186cm")	1C	00011100
22	16	Max V image size ("16.524cm")	10	00010000
23	17	Display Gamma (Gamma = "2.2")	78	01111000
24	18	Feature support	02	00000010
25	19	Red/Green (Rx1, Rx0, Ry1, Ry0, Gx1, Gx0, Gy1, Gy0)	A7	10100111
26	1A	Blue/White (Bx1, Bx0, By1, By0, Wx1, Wx0, Wy1, Wy0)	05	00000101
27	1B	Red-x (Rx = "0.650")	A6	10100110
28	1C	Red-y (Ry = "0.338")	56	01010110
29	1D	Green-x (Gx = "0.329")	54	01010100
30	1E	Green-y (Gy = "0.608")	9B	10011011
31	1F	Blue-x (Bx = "0.148")	26	00100110
32	20	Blue-y (By = "0.047")	0C	00001100
33	21	White-x (Wx = "0.313")	50	01010000
34	22	White-y (Wy = "0.329")	54	01010100
35	23	Established timings 1	00	00000000
36	24	Established timings 2	00	00000000
37	25	Manufacturer's reserved timings	00	00000000
38	26	Standard timing ID # 1	01	00000001
39	27	Standard timing ID # 1	01	00000001
40	28	Standard timing ID # 2	01	00000001
41	29	Standard timing ID # 2	01	00000001

深圳市诚易盛电子  
 TEL: 18818991580  
 QQ: 474684179



42	2A	Standard timing ID # 3	01	00000001
43	2B	Standard timing ID # 3	01	00000001
44	2C	Standard timing ID # 4	01	00000001
45	2D	Standard timing ID # 4	01	00000001
46	2E	Standard timing ID # 5	01	00000001
47	2F	Standard timing ID # 5	01	00000001
48	30	Standard timing ID # 6	01	00000001
49	31	Standard timing ID # 6	01	00000001
50	32	Standard timing ID # 7	01	00000001
51	33	Standard timing ID # 7	01	00000001
52	34	Standard timing ID # 8	01	00000001
53	35	Standard timing ID # 8	01	00000001
54	36	Detailed timing description # 1 Pixel clock ("138.78MHz", According to VESA CVT Rev1.4)	36	00110110
55	37	# 1 Pixel clock (hex LSB first)	36	00110110
56	38	# 1 H active ("1920")	80	10000000
57	39	# 1 H blank ("160")	A0	10100000
58	3A	# 1 H active : H blank ("1920 :160")	70	01110000
59	3B	# 1 V active ("1080")	38	00111000
60	3C	# 1 V blank ("32")	20	00100000
61	3D	# 1 V active : V blank ("1080 :32")	40	01000000
62	3E	# 1 H sync offset ("46")	2E	00101110
63	3F	# 1 H sync pulse width ("30")	1E	00011110
64	40	# 1 V sync offset : V sync pulse width ("2 : 4")	24	00100100
65	41	# 1 H sync offset : H sync pulse width : V sync offset : V sync width ("46: 30 : 2 : 4")	00	00000000
66	42	# 1 H image size ("282 mm")	1A	00011010
67	43	# 1 V image size ("165 mm")	A5	10100101
68	44	# 1 H image size : V image size ("282 : 165")	10	00010000
69	45	# 1 H boarder ("0")	00	00000000
70	46	# 1 V boarder ("0")	00	00000000
71	47	# 1 Non-interlaced, Normal, no stereo, Separate sync, H/V pol Negatives	18	00011000
72	48	Detailed timing description # 2 Pixel clock ("92.52MHz", According to VESA CVT Rev1.4)	24	00100100
73	49	# 2 Pixel clock (hex LSB first)	24	00100100
74	4A	# 2 H active ("1920")	80	10000000
75	4B	# 2 H blank ("160")	A0	10100000
76	4C	# 2 H active : H blank ("1920 :160")	70	01110000
77	4D	# 2 V active ("1080")	38	00111000
78	4E	# 2 V blank ("32")	20	00100000
79	4F	# 2 V active : V blank ("1080 :32")	40	01000000
80	50	# 2 H sync offset ("46")	2E	00101110
81	51	# 2 H sync pulse width ("30")	1E	00011110
82	52	# 2 V sync offset : V sync pulse width ("2 : 4")	24	00100100
83	53	# 2 H sync offset : H sync pulse width : V sync offset : V sync width ("46: 30 : 2 : 4")	00	00000000
84	54	# 1 H image size ("282 mm")	1A	00011010
85	55	# 1 V image size ("165 mm")	A5	10100101

18818991580 QQ:474684179  
 深圳市诚易盛电子有限公司

86	56	# 1 H image size : V image size ("282 : 165")	10	00010000
87	57	# 2 H boarder ("0")	00	00000000
88	58	# 2 V boarder ("0")	00	00000000
89	59	# 2 Non-interlaced, Normal, no stereo, Separate sync, H/V pol Negatives	18	00011000
90	5A	Detailed timing description # 3	00	00000000
91	5B	# 3 Flag	00	00000000
92	5C	# 3 Reserved	00	00000000
93	5D	# 3 FE (hex) defines ASCII string (Vendor "CMO", ASCII)	FE	11111110
94	5E	# 3 Flag	00	00000000
95	5F	# 3 1st character of string ("C")	43	01000011
96	60	# 3 2nd character of string ("M")	4D	01001101
97	61	# 3 3rd character of string ("N")	4E	01001110
98	62	# 3 New line character indicates end of ASCII string	0A	00001010
99	63	# 3 Padding with "Blank" character	20	00100000
100	64	# 3 Padding with "Blank" character	20	00100000
101	65	# 3 Padding with "Blank" character	20	00100000
102	66	# 3 Padding with "Blank" character	20	00100000
103	67	# 3 Padding with "Blank" character	20	00100000
104	68	# 3 Padding with "Blank" character	20	00100000
105	69	# 3 Padding with "Blank" character	20	00100000
106	6A	# 3 Padding with "Blank" character	20	00100000
107	6B	# 3 Padding with "Blank" character	20	00100000
108	6C	Detailed timing description # 4	00	00000000
109	6D	# 4 Flag	00	00000000
110	6E	# 4 Reserved	00	00000000
111	6F	# 4 FE (hex) defines ASCII string (Model Name"N156B3-L03", ASCII)	FE	11111110
112	70	# 4 Flag	00	00000000
113	71	# 4 1st character of name ("N")	4E	01001110
114	72	# 4 2nd character of name ("1")	31	00110001
115	73	# 4 3rd character of name ("3")	33	00110011
116	74	# 4 4th character of name ("3")	33	00110011
117	75	# 4 5th character of name ("H")	48	01001000
118	76	# 4 6th character of name ("S")	53	01010011
119	77	# 4 7th character of name ("E")	45	01000101
120	78	# 4 8th character of name ("-")	2D	00101101
121	79	# 4 9th character of name ("E")	45	01000101
122	7A	# 4 Ath character of name ("2")	32	00110010
123	7B	# 4 Bth character of name ("1")	31	00110001
124	7C	# 4 New line character indicates end of ASCII string	0A	00001010
125	7D	# 4 Padding with "Blank" character	20	00100000
126	7E	No extension	00	00000000
127	7F	Checksum	6A	01101010

Appendix. OUTLINE DRAWING

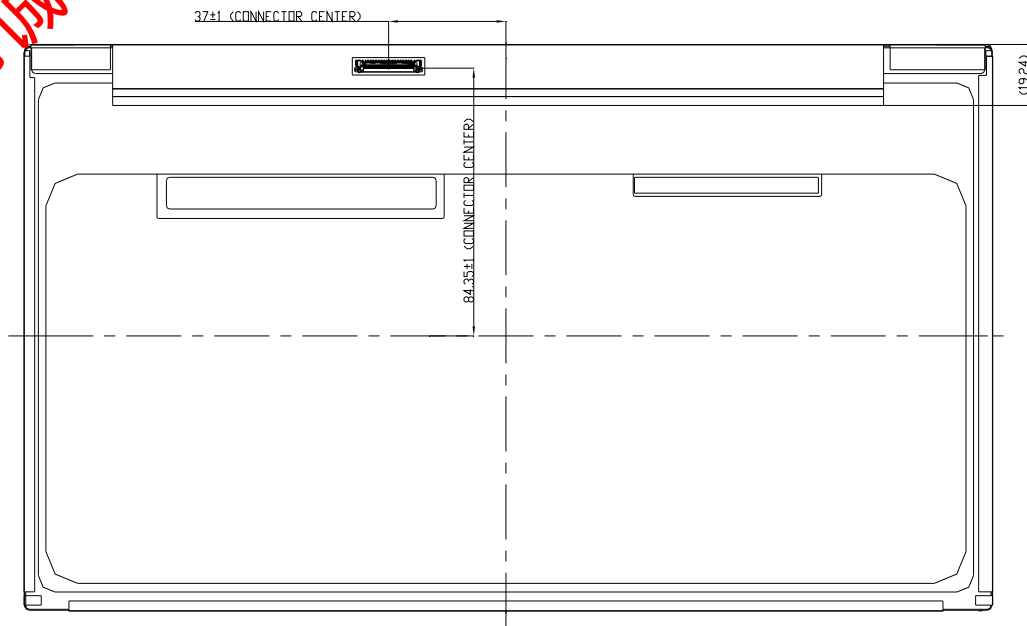
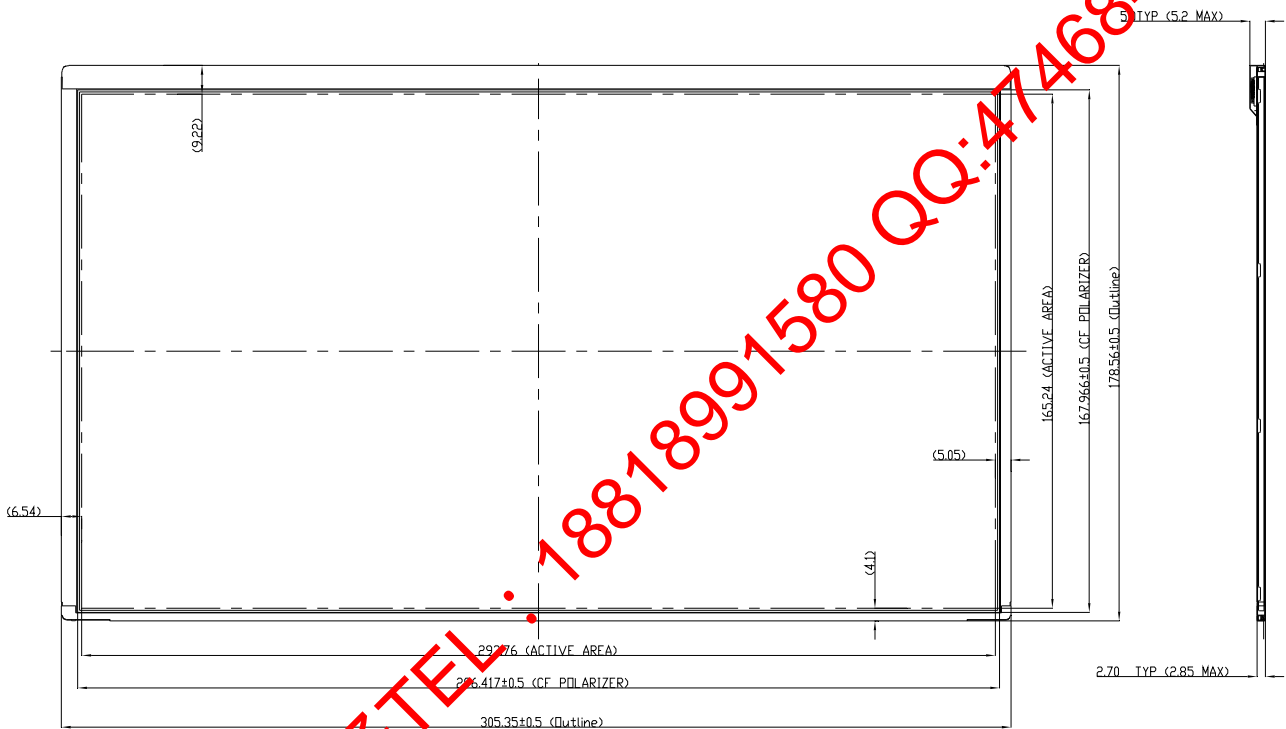

深圳市诚易盛电子TEL: 18818991580 QQ: 474684179

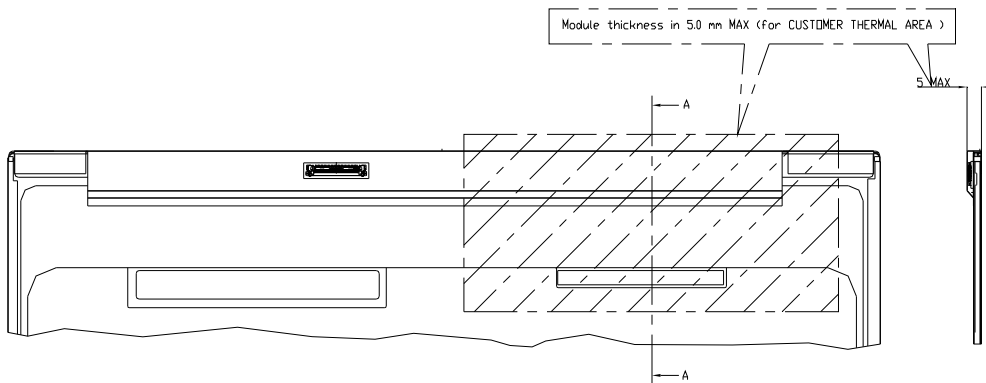
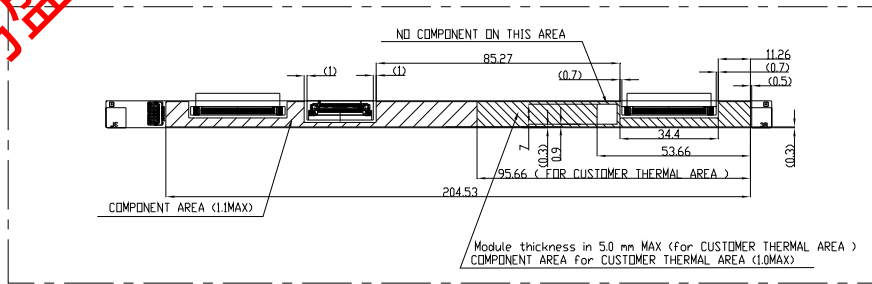
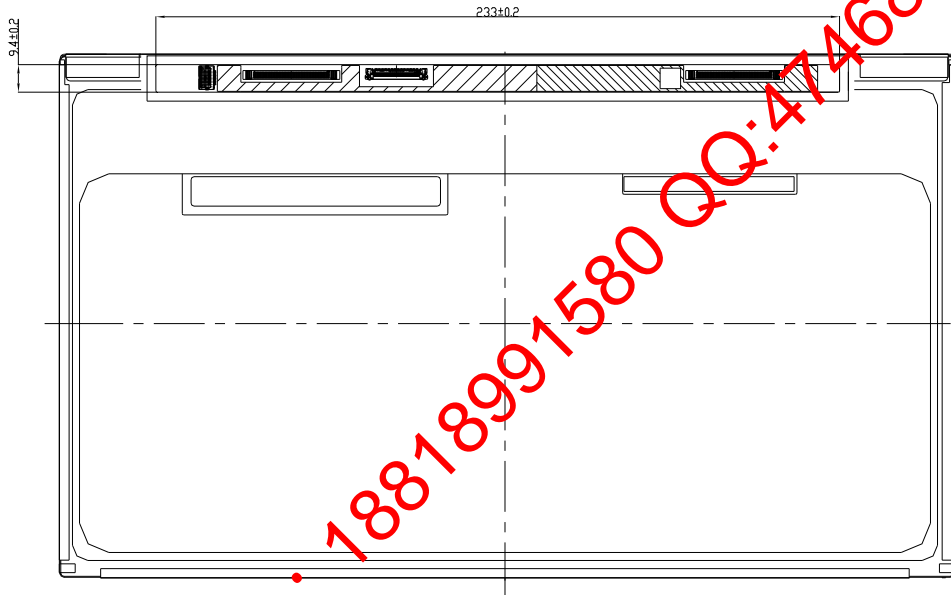

深圳市诚易盛电子 TEL: 18818991580 QQ: 474684179

Appendix. SYSTEM COVER DESIGN NOTICE

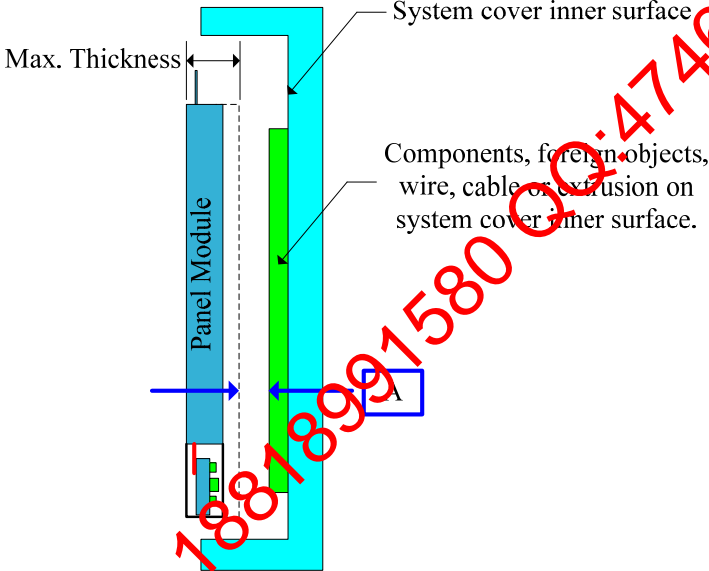
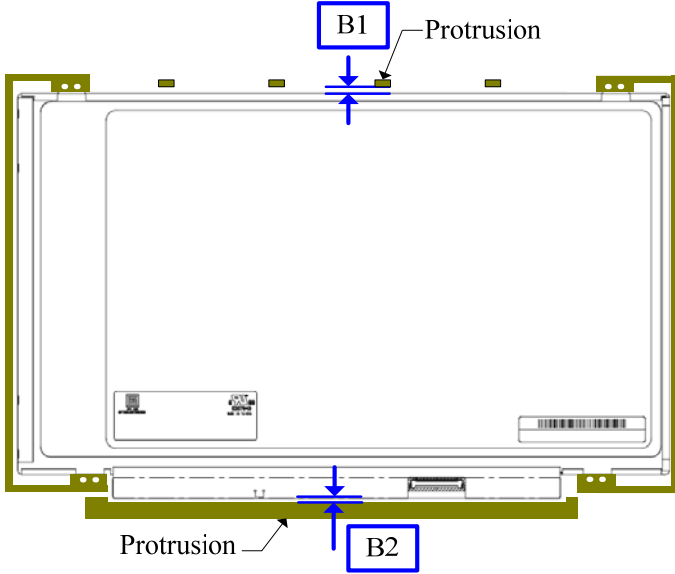
1.	<b>Design gap A between panel &amp; any components on system cover</b>
	
Definition	<p>a). Sufficient gap between panel &amp; system is a must for preventing from backpack or pogo test fail.</p> <p>b). Zero gap from panel's maximum thickness boundary to any components, foreign objects, wire, cable or extrusion on system cover inner surface is forbidden.</p>
2	<b>Design gap B1 &amp; B2 between panel &amp; protrusions</b>
	
Definition	2.0mm min. gap is recommended between panel & protrusions for preventing from shock related failures.
3	<b>Design gap C between system front bezel &amp; panel surface.</b>

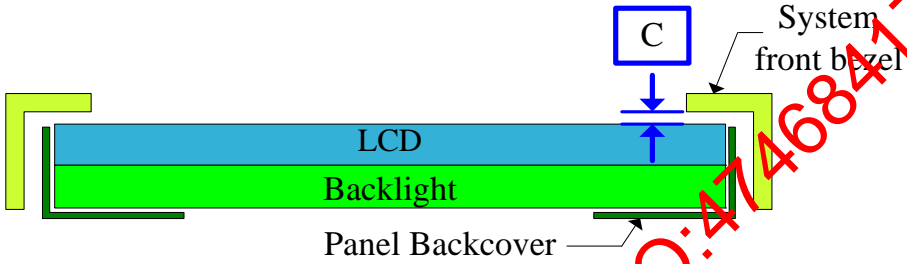
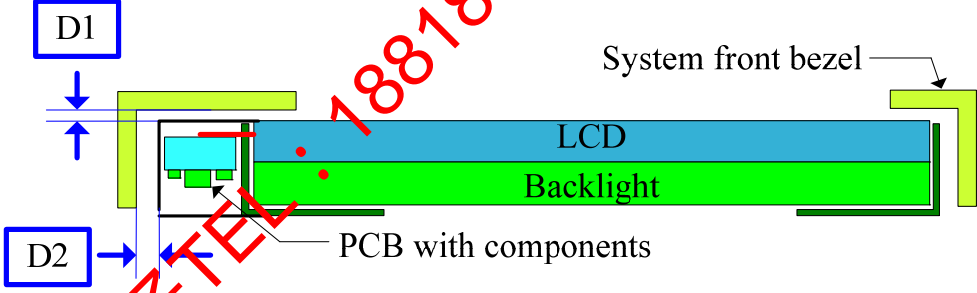
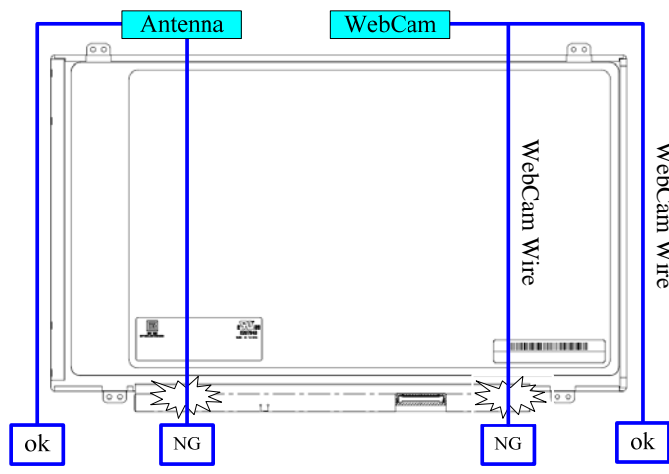
	 <p>System front bezel</p> <p>C</p> <p>LCD</p> <p>Backlight</p> <p>Panel Backcover</p>
Definition	<p>a). Sufficient gap between system front bezel &amp; panel surface is a must for preventing from pooling or glass broken.</p> <p>b). Zero gap or interference is forbidden.</p>
4	<b>Design gap D1 &amp; D2 between system front bezel &amp; PCB Assembly.</b>
	 <p>D1</p> <p>System front bezel</p> <p>LCD</p> <p>Backlight</p> <p>PCB with components</p> <p>D2</p>
Definition	<p>a). Sufficient gap between system front bezel &amp; PCB assembly is a must for preventing from abnormal display after backpack test, hinge test, twist test or pogo test.</p> <p>b). Zero gap or interference is forbidden.</p>
5	<b>Interference examination of antenna cable and WebCam wire</b>
	 <p>Antenna</p> <p>WebCam</p> <p>WebCam Wire</p> <p>WebCam Wire</p> <p>ok</p> <p>NG</p> <p>NG</p> <p>ok</p>
Definition	<p>a). Antenna cable or WebCam wire overlap with panel outline is forbidden for preventing from abnormal display &amp; white spot after backpack test, hinge test, twist test or pogo test.</p> <p>b). Antenna cable or WebCam wire bypass panel outline is recommended.</p>
6	<b>System inner surface examination</b>

深圳市诚易盛电子 TEL: 18818991580 QQ: 474684179

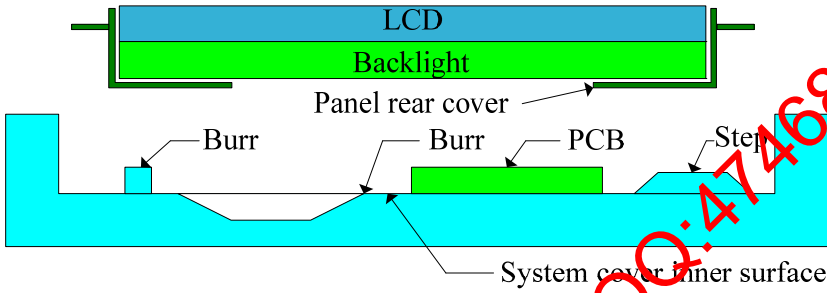
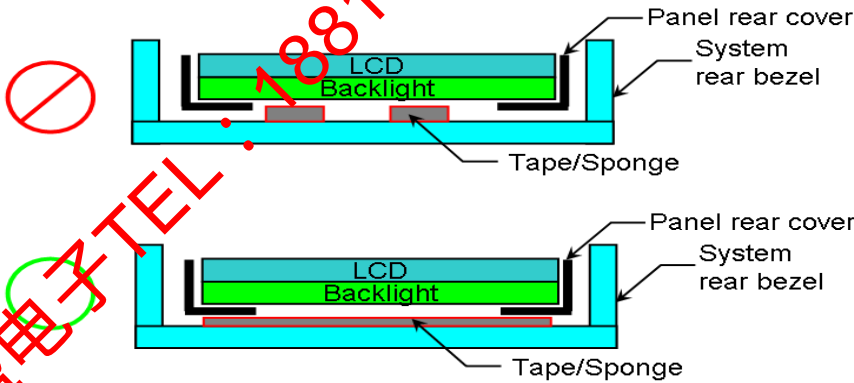
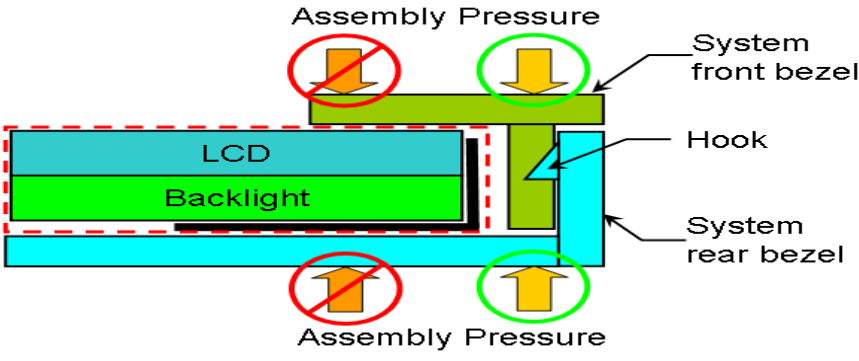
	
<p>Definition</p>	<p>a). Burr at logo edge, step, protrusion or PCB board will easily cause white spot or glass broken.</p> <p>b). Keeping flat surface underneath backlight is recommended.</p>
<p>7</p>	<p>Tape/sponge design on system inner surface</p>
	
<p>Definition</p>	<p>a) To prevent abnormal display &amp; white spot after scuffing test, hinge test, pogo test, backpack test, it is not recommended to add tape/sponge in separate location. Since each tape/sponge may act as pressure concentration location.</p> <p>b) We suggest to design a tape/sponge that well covered under panel rear cover.</p>
<p>8</p>	<p>Assembly SOP examination</p>
	
<p>Definition</p>	<p>To prevent panel crack during system front bezel assembly process with hook design, it is prohibited to press panel or any location that related directly to the panel.</p>
<p>9</p>	<p>Material used for system rear bezel</p>

深圳市诚易盛电子 TEL: 18878991580

QQ: 474684179

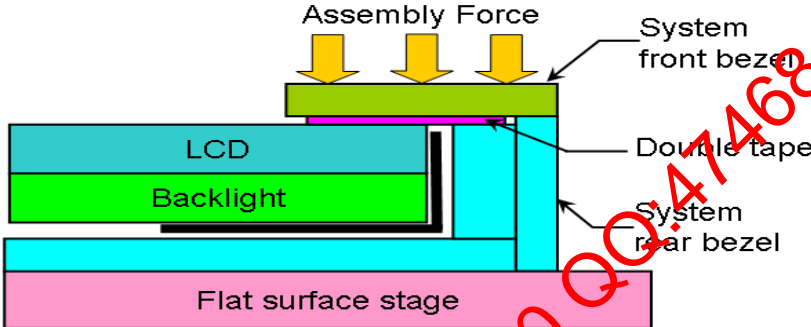
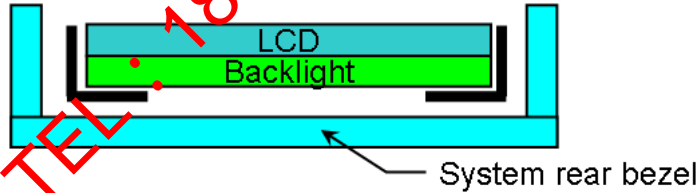
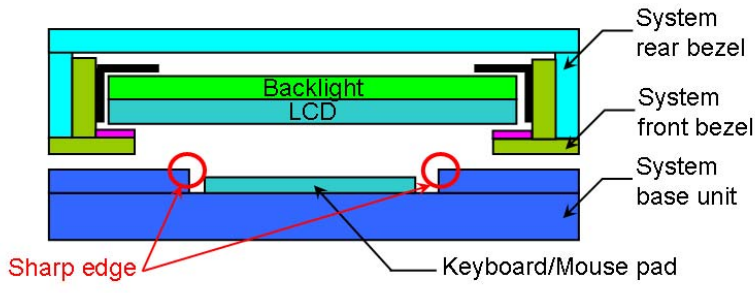
	
<p>Definition</p>	<p>To prevent panel crack during system front bezel assembly process without hook design, it is only allowed to give slight pressure with large contact area. This can help to distribute the stress to prevent point concentration. Also it is suggest to put the system on a flat surface stage during the assembly.</p>
<p>10</p>	<p>Material used for system rear bezel</p>
	
<p>Definition</p>	<p>a) To prevent abnormal display &amp; white spot after scuffing test, hinge test, pogo test, backpack test, as the poor rigidity result from deformation of system rear cover during the test.</p> <p>b) We suggest to use aluminum-magnesium alloy as the rear frame material with thickness min 1.5mm, instead of using PC/ABS.</p>
<p>11</p>	<p>System base unit design near keyboard and mouse pad</p>
	
<p>Definition</p>	<p>To prevent abnormal display &amp; white spot after scuffing test, hinge test, pogo test, backpack test, no sharp edge design is allowed in any area that may damage the panel during the test. We suggest to remove all sharp edges, or to reduce the thickness difference of keyboard/mouse pad from the nearby surface.</p>