

- Tentative Specification
- Preliminary Specification
- Approval Specification

MODEL NO.: N133IGE

Customer: Apple

APPROVED BY

SIGNATURE

Name / Title _____

Note

Please return 1 copy for your confirmation with your signature and comments.

Approved By	Checked By	Prepared By
Sailor.Yang	Stephen.Chen	Robert.Yang

CONTENTS

1. GENERAL DESCRIPTION	4
1.1 OVERVIEW	4
1.2 GENERAL SPECIFICATIONS.....	4
2. MECHANICAL SPECIFICATIONS	4
2.1 CONNECTOR TYPE	4
3. ABSOLUTE MAXIMUM RATINGS	5
3.1 ABSOLUTE RATINGS OF ENVIRONMENT.....	5
3.2 ELECTRICAL ABSOLUTE RATINGS	5
3.2.1 TFT LCD MODULE.....	5
4. ELECTRICAL SPECIFICATIONS	6
4.1 FUNCTION BLOCK DIAGRAM	6
4.2. INTERFACE CONNECTIONS	6
4.3 ELECTRICAL CHARACTERISTICS.....	8
4.3.1 LCD ELECTRONICS SPECIFICATION.....	8
4.3.2 BACKLIGHT UNIT.....	10
4.4 LVDS INPUT SIGNAL TIMING SPECIFICATIONS.....	10
4.4.1 LVDS DC SPECIFICATIONS.....	10
4.4.2 LVDS DATA FORMAT.....	11
4.4.3 COLOR DATA INPUT ASSIGNMENT.....	11
4.5 DISPLAY TIMING SPECIFICATIONS.....	13
4.6 POWER ON/OFF SEQUENCE	14
5. OPTICAL CHARACTERISTICS	15
5.1 TEST CONDITIONS	15
5.2 OPTICAL SPECIFICATIONS.....	15
6. RELIABILITY TEST ITEM	15
7. PACKING	20
7.1 MODULE LABEL	20
7.2 CARTON	21
7.3 PALLET	22
8. PRECAUTIONS	23
8.1 HANDLING PRECAUTIONS	23
8.2 STORAGE PRECAUTIONS	23
8.3 OPERATION PRECAUTIONS.....	23
Appendix. EDID DATA STRUCTURE	24
Appendix. OUTLINE DRAWING.....	27

REVISION HISTORY

Version	Date	Page	Description
0.0	July.1, 2011	All	Spec Ver.0.0 was first issued.
1.0	July.4, 2011	29	Modify 2D drawing.
2.0	Aug.11, 2011	23	Modify packing structure.
3.0	Aug.22, 2011	All	Approval Specification was first issued

1. GENERAL DESCRIPTION

1.1 OVERVIEW

N133IGE – L43 is a 13.3" TFT Liquid Crystal Display module with LED Backlight unit and 30 pins LVDS interface. This module supports 1280 x 800 WXGA mode and can display 262,144 colors. The optimum viewing angle is at 6 o'clock direction. The converter module for Backlight is not built in.

1.2 GENERAL SPECIFICATIONS

Item	Specification	Unit	Note
Screen Size	13.3 diagonal		
Driver Element	a-si TFT active matrix	-	-
Pixel Number	1280 x R.G.B. x 800	pixel	-
Pixel Pitch	0.2235 (H) x 0.2235 (V)	mm	-
Pixel Arrangement	RGB vertical stripe	-	-
Display Colors	262,144	color	-
Transmissive Mode	Normally white	-	-
Surface Treatment	Glare, APCF , 3H	-	-
Luminance, White	330	Cd/m2	
Power Consumption	Total 4.61 W (Max.) @ cell 0.86W (Max.), BL 3.75 W (Max.)		(1)

Note (1) The specified power consumption (with converter efficiency) is under the conditions at VCCS = 3.3 V, $f_v = 60$ Hz, LED_VCCS = Typ, fPWM = 200 Hz, Duty=100% and $T_a = 25 \pm 2$ °C, whereas mosaic pattern is displayed.

2. MECHANICAL SPECIFICATIONS

Item		Min.	Typ.	Max.	Unit	Note
Module Size	Horizontal (H)	296.85	297.15	297.45	mm	(1)
	Vertical (V)	202.8	203.2	203.6	mm	
	Thickness (T)	3.15	3.45	3.75	mm	
Bezel Area	Horizontal	-	-	-	mm	
	Vertical	-	-	-	mm	
Active Area	Horizontal	-	286.08	-	mm	
	Vertical	-	178.8	-	mm	
Weight		--	--	310	g	

Note (1) Please refer to the attached drawings for more information of front and back outline dimensions.

2.1 CONNECTOR TYPE

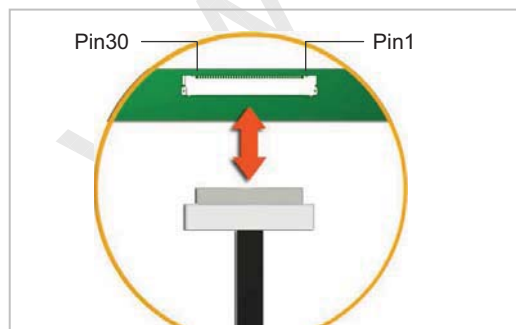

Please refer Appendix Outline Drawing for detail design.

Connector Part No.: 20474-030E-12(I-PEX) or equivalent

User's connector Part No: 20472-030T-10(I-PEX) or equivalent

3. ABSOLUTE MAXIMUM RATINGS

3.1 ABSOLUTE RATINGS OF ENVIRONMENT

Item	Symbol	Value		Unit	Note
		Min.	Max.		
Storage Temperature	T _{ST}	-20	+60	°C	(1)
Operating Ambient Temperature	T _{OP}	0	+50	°C	(1), (2)

Note (1) (a) 90 %RH Max. (Ta <= 40 °C).

(b) Wet-bulb temperature should be 39 °C Max. (Ta > 40 °C).

(c) No condensation.

Note (2) The temperature of panel surface should be 0 °C min. and 60 °C max.

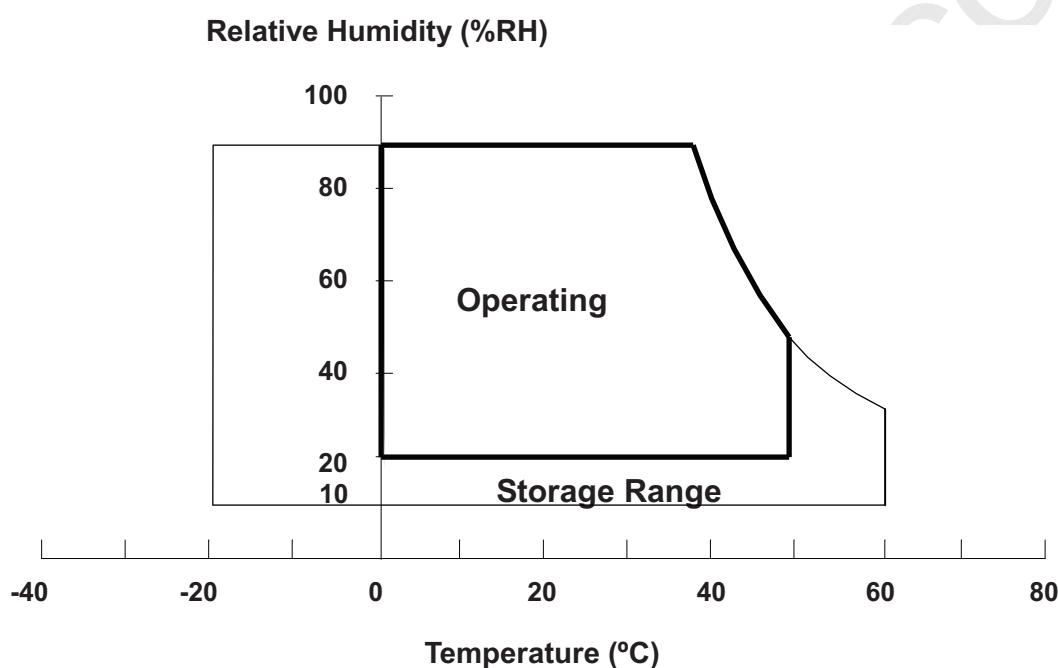

3.2 ELECTRICAL ABSOLUTE RATINGS

3.2.1 TFT LCD MODULE

Item	Symbol	Value		Unit	Note
		Min.	Max.		
Power Supply Voltage	V _{CCS}	-0.3	+4.0	V	(1)
Logic Input Voltage	V _{IN}	-0.3	V _{CCS} +0.3	V	

Note (1) Stresses beyond those listed in above "ELECTRICAL ABSOLUTE RATINGS" may cause permanent damage to the device. Normal operation should be restricted to the conditions described in "ELECTRICAL CHARACTERISTICS".

4. ELECTRICAL SPECIFICATIONS

4.1 FUNCTION BLOCK DIAGRAM

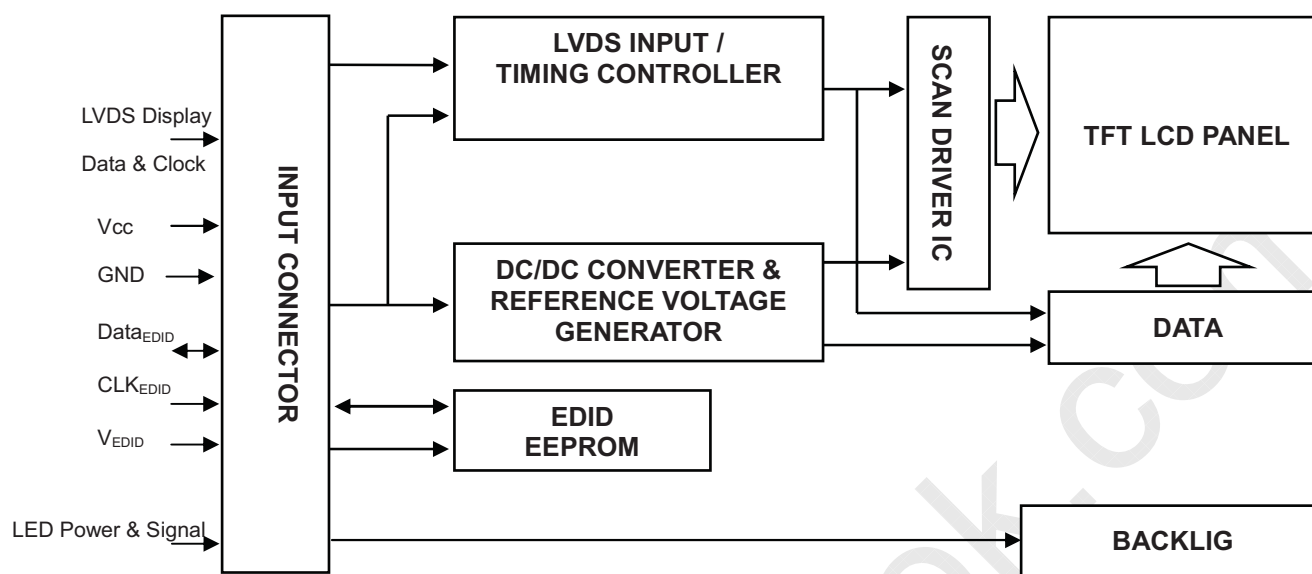

4.2. INTERFACE CONNECTIONS

PIN ASSIGNMENT

Pin	Symbol	Description	Polarity	Remark
1	Vss	Ground		
2	Vcc	Power Supply +3.3 V (typical)		
3	Vcc	Power Supply +3.3 V (typical)		
4	V _{EDID}	DDC 3.3V Power		DDC 3.3V Power
5	NC	No connect		
6	CLK _{EDID}	DDC Clock		DDC Clock
7	DATA _{EDID}	DDC Data		DDC Data
8	Rxin0-	LVDS Differential Data Input	Negative	R0~R5,G0
9	Rxin0+	LVDS Differential Data Input	Positive	-
10	Vss	Ground		
11	Rxin1-	LVDS Differential Data Input	Negative	G1~G5, B0, B1
12	Rxin1+	LVDS Differential Data Input	Positive	-
13	Vss	Ground		
14	Rxin2-	LVDS Differential Data Input	Negative	B2~B5, DE, Hsync, Vsync
15	Rxin2+	LVDS Differential Data Input	Positive	
16	Vss	Ground		
17	CLK-	LVDS Clock Data Input	Negative	LVDS Level Clock
18	CLK+	LVDS Clock Data Input	Positive	
19	Vss	Ground		
20	Vss	Ground		
21	Vdc(1&2&3)	LED Annode (Positive)		
22	Vdc(4&5&6)	LED Annode (Positive)		
23	NC	No connect		
24	Vdc1	LED Cathode (Negative)		
25	Vdc2	LED Cathode (Negative)		
26	Vdc3	LED Cathode (Negative)		

27	Vdc4	LED Cathode (Negative)		
28	Vdc5	LED Cathode (Negative)		
29	Vdc6	LED Cathode (Negative)		
30	Vss	Ground		

Note (1) The first pixel is odd as shown in the following figure.

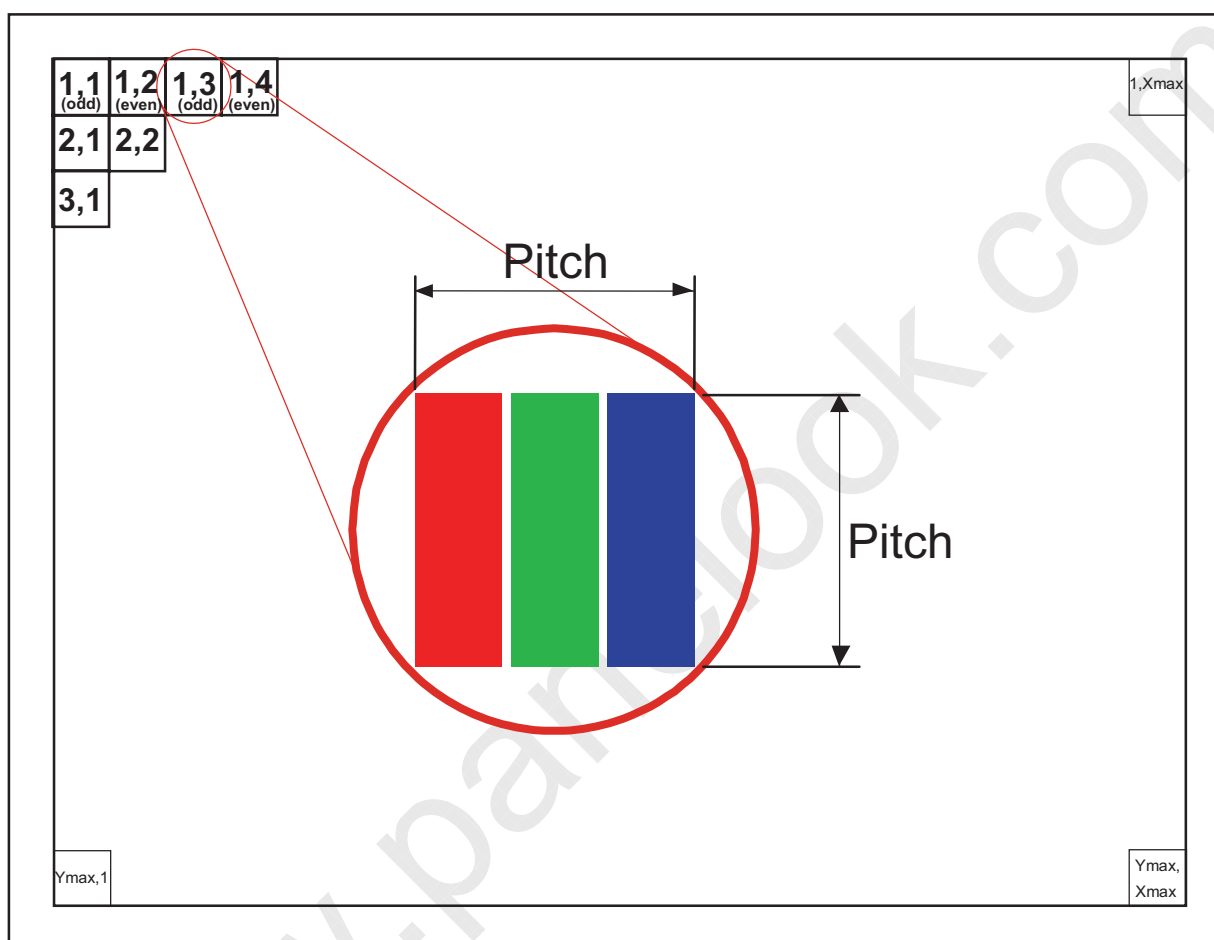

4.3 ELECTRICAL CHARACTERISTICS

4.3.1 LCD ELETRONICS SPECIFICATION

Parameter	Symbol	Value			Unit	Note
		Min.	Typ.	Max.		
Power Supply Voltage	VCCS	3.0	3.3	3.6	V	(1)-
Ripple Voltage	V _{RP}	-	50	-	mV	(1)-
Inrush Current	I _{RUSH}	-	-	1.5	A	(1),(2)
Power Supply Current	Mosaic	-	230	260	mA	(3)a
	Black	-	250	280	mA	(3)b

Note (1) The ambient temperature is $T_a = 25 \pm 2 \text{ }^\circ\text{C}$.

Note (2) I_{RUSH}: the maximum current when VCCS is rising

I_{IS}: the maximum current of the first 100ms after power-on

Measurement Conditions: Shown as the following figure. Test pattern: black.

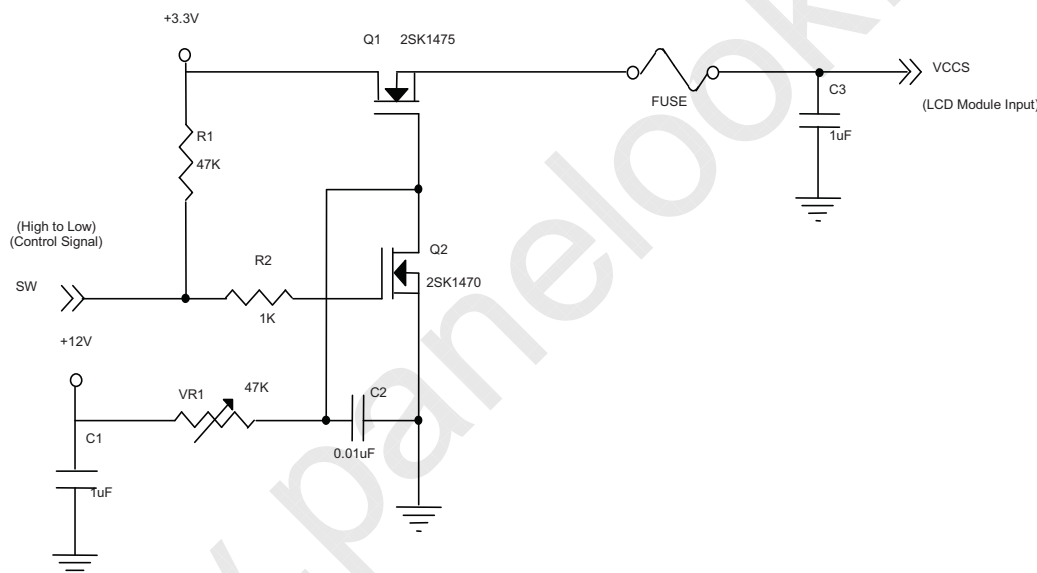

VCCS rising time is 0.5ms

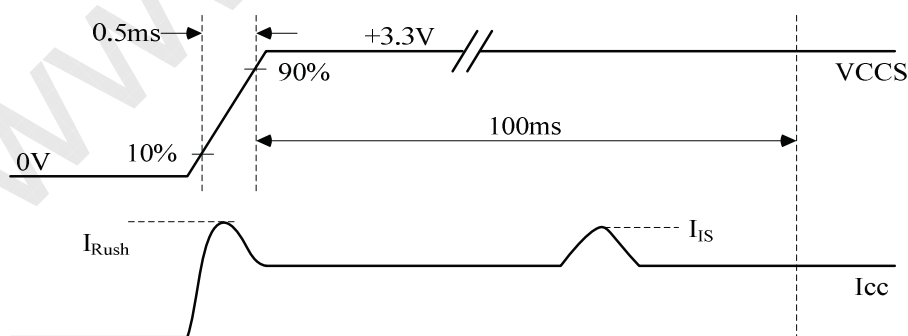

Note (3) The specified power supply current is under the conditions at $V_{CCS} = 3.3\text{ V}$, $T_a = 25 \pm 2\text{ }^\circ\text{C}$, DC Current and $f_v = 60\text{ Hz}$, whereas a power dissipation check pattern below is displayed.

a. Mosaic Pattern

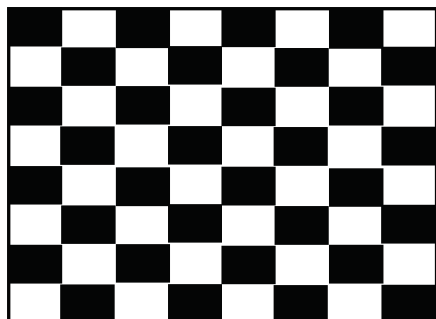

Active Area

b. Black Pattern



Active Area

www.panelook.com

4.3.2 BACKLIGHT UNIT

 $T_a = 25 \pm 2 \text{ }^\circ\text{C}$

Parameter	Symbol	Value			Unit	Note
		Min.	Typ.	Max.		
LED Light Bar Power Supply Voltage	V_L	25.2	26.1	27	V	(1),(2) (Duty 100%)
LED Light Bar Power Supply Current	I_L	125	132	139	mA	
Power Consumption	P_L	3.15	3.45	3.75	W	(3), (Duty 100%)
LED Life Time	L_{BL}	12000	--	--	Hrs	(4)

Note (1) LED current is measured by utilizing a high frequency current meter as shown below :

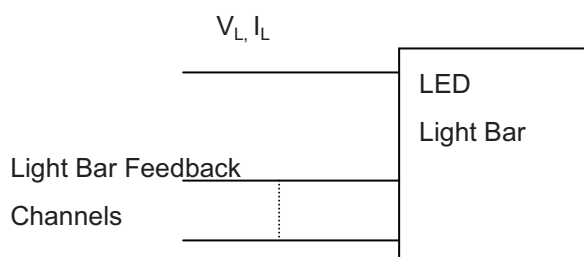

Note (2) For better LED light bar driving quality, it is recommended to utilize the adaptive boost converter with current balancing function to drive LED light-bar.

Note (3) $P_L = I_L \times V_L$ (Without LED converter transfer efficiency)

Note (4) The lifetime of LED is defined as the time when it continues to operate under the conditions at $T_a = 25 \pm 2 \text{ }^\circ\text{C}$ and $I_L = 23 \text{ mA}$ (Per EA) until the brightness becomes $\leq 50\%$ of its original value.

4.4 LVDS INPUT SIGNAL TIMING SPECIFICATIONS

4.4.1 LVDS DC SPECIFICATIONS

Parameter	Symbol	Value			Unit	Note
		Min.	Typ.	Max.		
LVDS Differential Input High Threshold	$V_{TH(LVDS)}$	-	-	+100	mV	(1), $V_{CM}=1.2V$
LVDS Differential Input Low Threshold	$V_{TL(LVDS)}$	-100	-	-	mV	(1), $V_{CM}=1.2V$
LVDS Common Mode Voltage	V_{CM}	1.125	-	1.375	V	(1)
LVDS Differential Input Voltage	$ V_{ID} $	100	-	600	mV	(1)
LVDS Terminating Resistor	R_T	-	100	-	Ohm	-

Note (1) The parameters of LVDS signals are defined as the following figures.

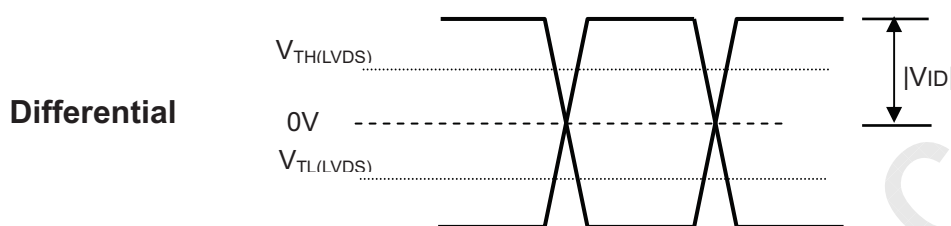
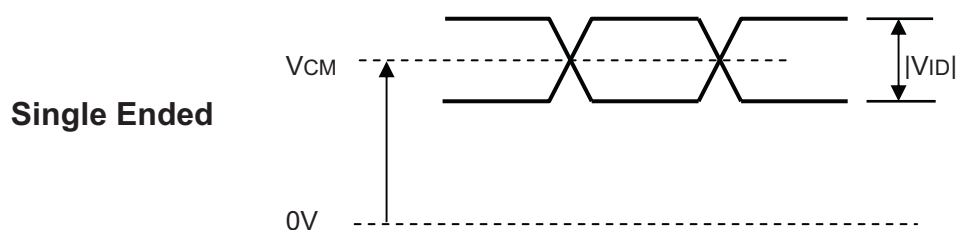

4.4.2 LVDS DATA FORMAT

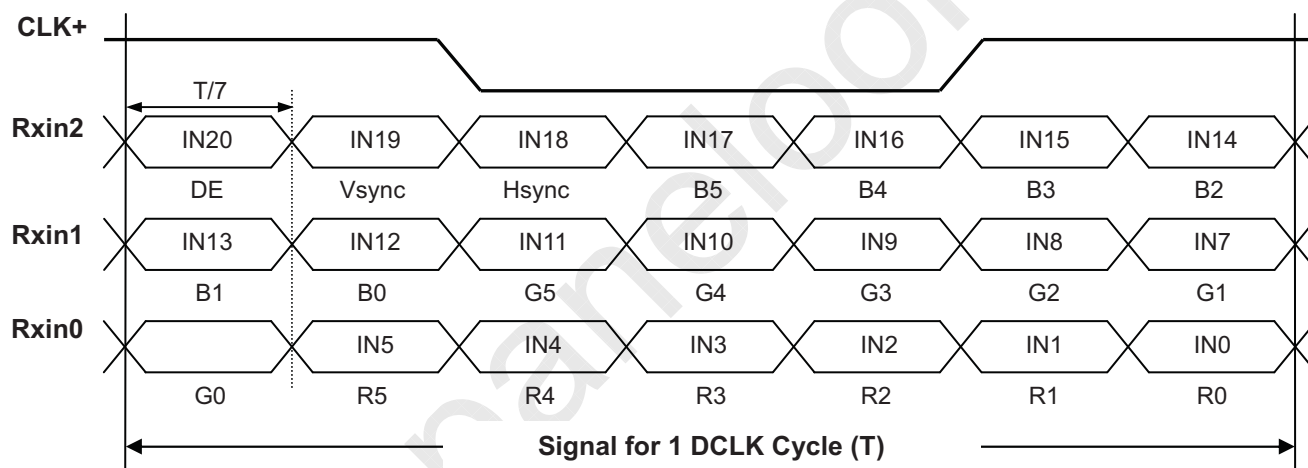

4.4.3 COLOR DATA INPUT ASSIGNMENT

The brightness of each primary color (red, green and blue) is based on the 6-bit gray scale data input for the color. The higher the binary input the brighter the color. The table below provides the assignment of color versus data input.

Color	Data Signal																	
	Red						Green						Blue					
	R5	R4	R3	R2	R1	R0	G5	G4	G3	G2	G1	G0	B5	B4	B3	B2	B1	B0
Basic Colors	Black	0	0	0	0	0	0	0	0	0	0	0	0	0	0	0	0	0
Red	1	1	1	1	1	1	0	0	0	0	0	0	0	0	0	0	0	0
Green	0	0	0	0	0	0	1	1	1	1	1	1	0	0	0	0	0	0
Blue	0	0	0	0	0	0	0	0	0	0	0	0	1	1	1	1	1	1
Cyan	0	0	0	0	0	0	1	1	1	1	1	1	1	1	1	1	1	1
Magenta	1	1	1	1	1	1	0	0	0	0	0	0	1	1	1	1	1	1
Yellow	1	1	1	1	1	1	1	1	1	1	1	1	0	0	0	0	0	0
White	1	1	1	1	1	1	1	1	1	1	1	1	1	1	1	1	1	1

Gray Scale Of Red	Red(0)/Dark	0	0	0	0	0	0	0	0	0	0	0	0	0	0	0	0	0
	Red(1)	0	0	0	0	0	1	0	0	0	0	0	0	0	0	0	0	0
	Red(2)	0	0	0	0	1	0	0	0	0	0	0	0	0	0	0	0	0
	:	:	:	:	:	:	:	:	:	:	:	:	:	:	:	:	:	:
	:	:	:	:	:	:	:	:	:	:	:	:	:	:	:	:	:	:
	:	:	:	:	:	:	:	:	:	:	:	:	:	:	:	:	:	:
	Red(61)	1	1	1	1	0	1	0	0	0	0	0	0	0	0	0	0	0
Red(62)	1	1	1	1	1	0	0	0	0	0	0	0	0	0	0	0	0	
Red(63)	1	1	1	1	1	1	0	0	0	0	0	0	0	0	0	0	0	
Gray Scale Of Green	Green(0)/Dark	0	0	0	0	0	0	0	0	0	0	0	0	0	0	0	0	0
	Green(1)	0	0	0	0	0	0	0	0	0	0	1	0	0	0	0	0	0
	Green(2)	0	0	0	0	0	0	0	0	0	0	1	0	0	0	0	0	0
	:	:	:	:	:	:	:	:	:	:	:	:	:	:	:	:	:	:
	:	:	:	:	:	:	:	:	:	:	:	:	:	:	:	:	:	:
	:	:	:	:	:	:	:	:	:	:	:	:	:	:	:	:	:	:
	Green(61)	0	0	0	0	0	0	1	1	1	1	0	1	0	0	0	0	0
Green(62)	0	0	0	0	0	0	1	1	1	1	1	0	0	0	0	0	0	
Green(63)	0	0	0	0	0	0	1	1	1	1	1	1	0	0	0	0	0	
Gray Scale Of Blue	Blue(0)/Dark	0	0	0	0	0	0	0	0	0	0	0	0	0	0	0	0	0
	Blue(1)	0	0	0	0	0	0	0	0	0	0	0	0	0	0	0	0	1
	Blue(2)	0	0	0	0	0	0	0	0	0	0	0	0	0	0	0	1	0
	:	:	:	:	:	:	:	:	:	:	:	:	:	:	:	:	:	:
	:	:	:	:	:	:	:	:	:	:	:	:	:	:	:	:	:	:
	:	:	:	:	:	:	:	:	:	:	:	:	:	:	:	:	:	:
	Blue(61)	0	0	0	0	0	0	0	0	0	0	0	1	1	1	1	0	1
Blue(62)	0	0	0	0	0	0	0	0	0	0	0	1	1	1	1	1	0	
Blue(63)	0	0	0	0	0	0	0	0	0	0	0	1	1	1	1	1	1	

Note (1) 0: Low Level Voltage, 1: High Level Voltage

4.5 DISPLAY TIMING SPECIFICATIONS

The input signal timing specifications are shown as the following table and timing diagram.

Signal	Item	Symbol	Min.	Typ.	Max.	Unit	Note
DCLK	Frequency	1/Tc	50	71	80	MHz	-
DE	Vertical Total Time	TV	803	823	1028	TH	-
	Vertical Active Display Period	TVD	800	800	800	TH	-
	Vertical Active Blanking Period	TVB	TV-TVD	23	TV-TVD	TH	-
	Horizontal Total Time	TH	1362	1440	1800	Tc	-
	Horizontal Active Display Period	THD	1280	1280	1280	Tc	-
	Horizontal Active Blanking Period	THB	TH-THD	160	TH-THD	Tc	-

Note (1) Because this module is operated by DE only mode, Hsync and Vsync are ignored.

INPUT SIGNAL TIMING DIAGRAM

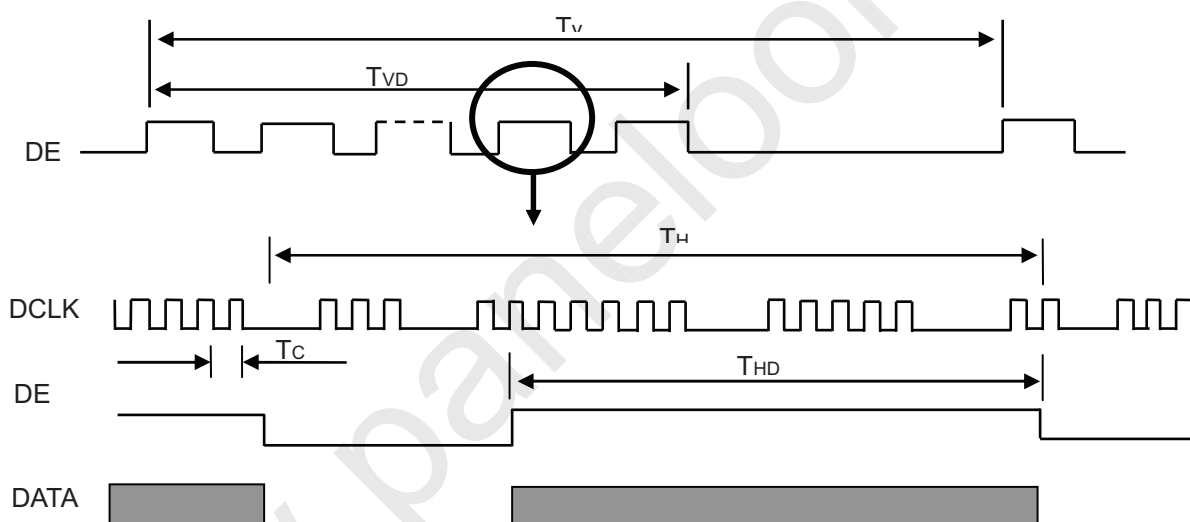

4.6 POWER ON/OFF SEQUENCE

The power sequence specifications are shown as the following table and diagram.

Symbol	Value			Unit	Note
	Min.	Typ.	Max.		
t1	0.5	-	10	ms	
t2	0	-	50	ms	
t3	0	-	50	ms	
t4	500	-	-	ms	
t5	200	-	-	ms	
t6	200	-	-	ms	

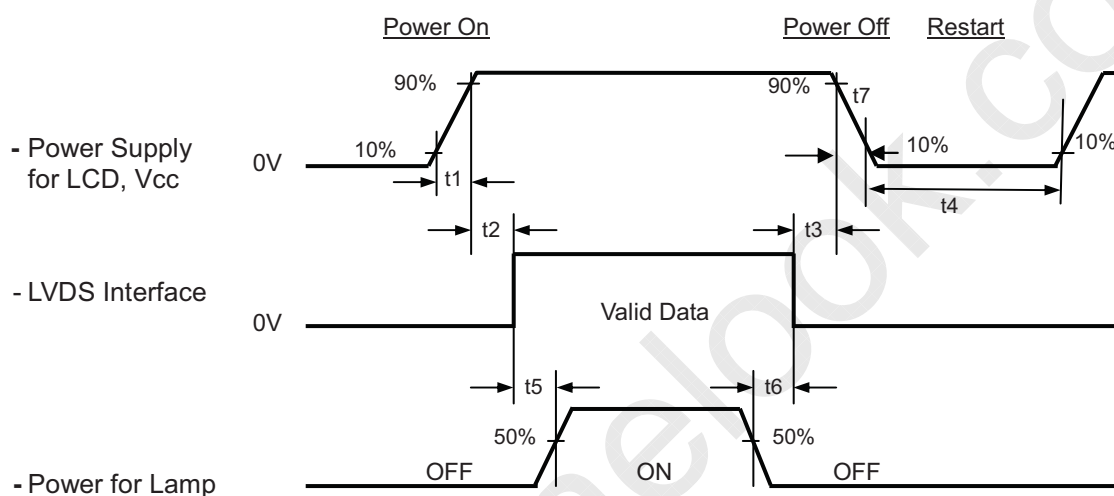

Note (1) Please follow the power on/off sequence described above. Otherwise, the LCD module might be damaged.

Note (2) Please avoid floating state of interface signal at invalid period. When the interface signal is invalid, be sure to pull down the power supply of LCD Vcc to 0 V.

Note (3) The Backlight converter power must be turned on after the power supply for the logic and the interface signal is valid. The Backlight converter power must be turned off before the power supply for the logic and the interface signal is invalid.

Note (4) Sometimes some slight noise shows when LCD is turned off (even backlight is already off). To avoid this phenomenon, we suggest that the Vcc falling time is better to follow

$$5 \leq t7 \leq 300 \text{ ms.}$$

5. OPTICAL CHARACTERISTICS

5.1 TEST CONDITIONS

Item	Symbol	Value	Unit
Ambient Temperature	T _a	25±2	°C
Ambient Humidity	H _a	50±10	%RH
Supply Voltage	V _{CC}	3.3	V
Input Signal	According to typical value in "3. ELECTRICAL CHARACTERISTICS"		
LED Light Bar Input Current	I _L	132	mA

The measurement methods of optical characteristics are shown in Section 5.2. The following items should be measured under the test conditions described in Section 5.1 and stable environment shown in Note (5).

5.2 OPTICAL SPECIFICATIONS

Item		Symbol	Condition	Min.	Typ.	Max.	Unit	Note
Contrast Ratio		CR	θ _x =0°, θ _y =0° Viewing Normal Angle	450	700	-	-	(2), (5)
Response Time		T _R		-	3	10	ms	(3)
		T _F		-	7	15	ms	
Center Luminance of White		L _{ct}		270	340	-	cd/m ²	(4), (5)
Luminance Uniformity		U		50	-	-	%	(5)
Color Chromaticity	Red	R _x		Typ (+0.05)	Typ (+0.05)	0.640	-	(5)
		R _y				0.335		
	Green	G _x				0.315		
		G _y				0.615		
	Blue	B _x				0.150		
		B _y	0.060					
	White	W _x	0.313					
		W _y	0.329					
Viewing Angle	Horizontal	θ _{x+}	50	70	-	Deg.	(1)	
		θ _{x-}	50	70				
	Vertical	θ _{y+}	45	55				
		θ _{y-}	45	55				

Note (1) Definition of Viewing Angle (θ_x, θ_y):

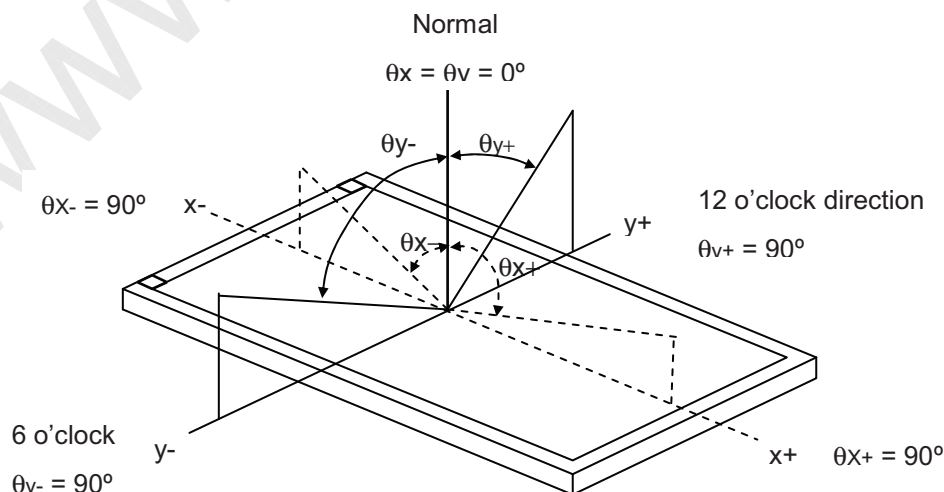

Note (2) Definition of Contrast Ratio (CR):

The contrast ratio can be calculated by the following expression.

$$\text{Contrast Ratio (CR)} = L_{63} / L_0$$

L63: Luminance of gray level 63

L 0: Luminance of gray level 0

$$\text{CR} = \text{CR} (1)$$

CR (X) is corresponding to the Contrast Ratio of the point X at Figure in Note (7).

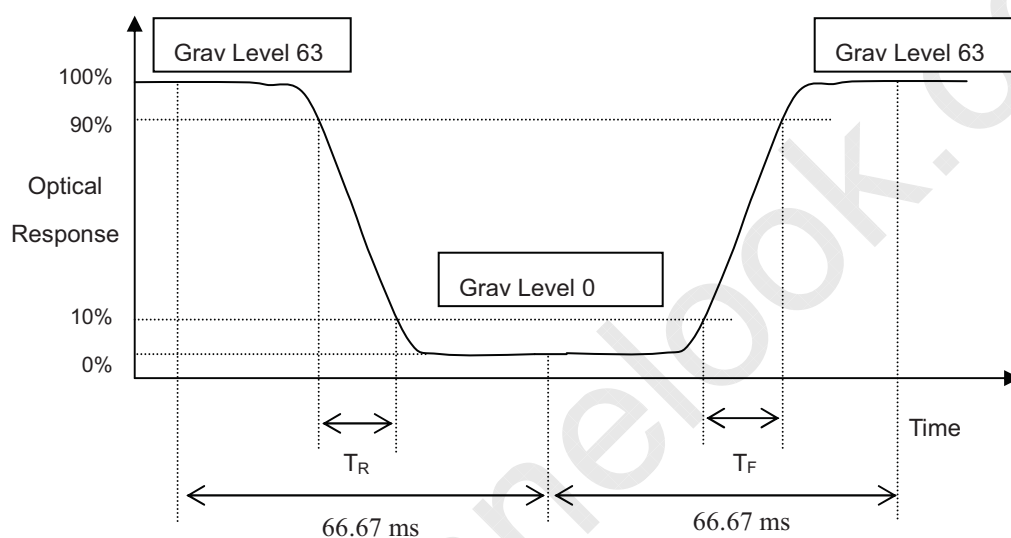
Note (3) Definition of Response Time (T_R , T_F):

Note (4) Definition of Center Luminance of White (L_{ct}):

Measure the luminance of gray level 63 at center points

$$L_{ct} = L (1)$$

L (x) is corresponding to the luminance of the point X at Figure in Note (7).

Note (5) Measurement Setup:

The LCD module should be stabilized at given temperature for 15 minutes to avoid abrupt temperature change during measuring. In order to stabilize the luminance, the measurement should be executed after lighting Backlight for 15 minutes in a windless room.

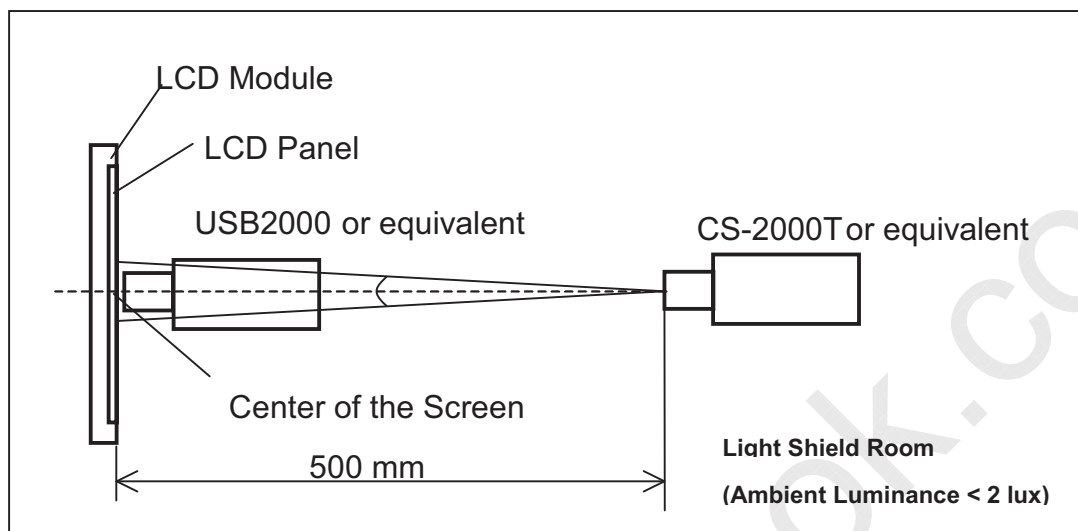

Note (6) Definition of Cross-talk (D_{SHA})

$$D_{SHA} = |Y_B - Y_A| / Y_A \times 100 (\%)$$

Where:

Y_A = Luminance of measured location without gray level 0 pattern (cd/m^2)

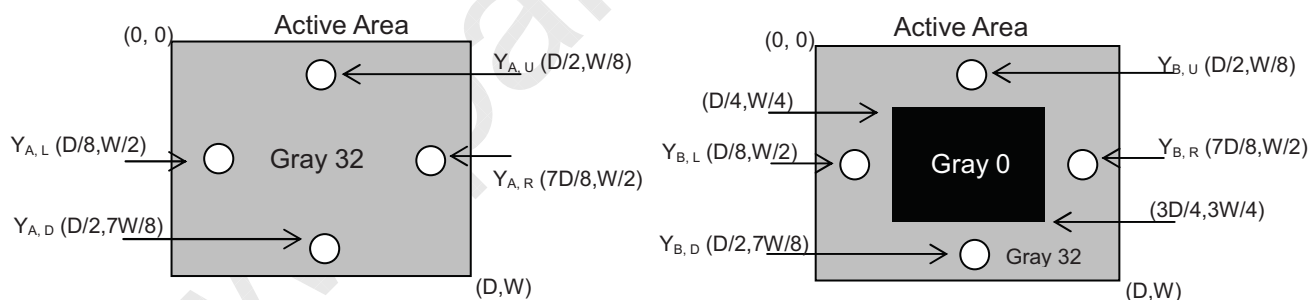
Y_B = Luminance of measured location with gray level 0 pattern (cd/m^2)



Note (7) Definition of White Variation (δW):

Measure the luminance of gray level 63 at 5 points

$$\delta W_{5p} = \{ \text{Minimum [L (1) ~ L (5)]} / \text{Maximum [L (1) ~ L (5)]} \} * 100\%$$

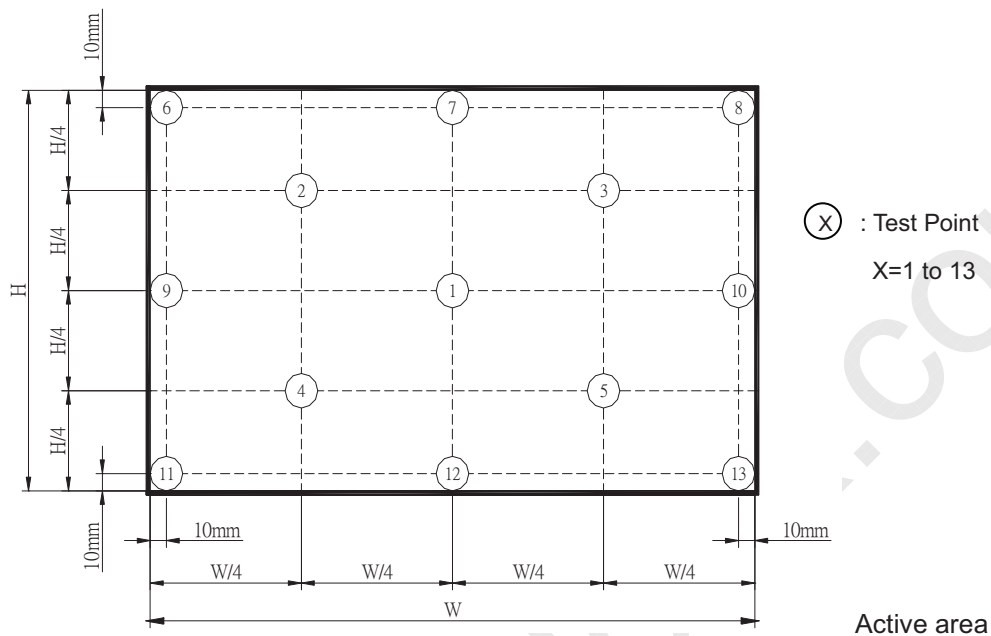

Note (12) The listed optical specifications refer to the initial value of manufacture, but the condition of the specifications after long-term operation will not be warranted.

6. RELIABILITY TEST ITEM

Test Item	Test Condition	Note
High Temperature Storage Test	60°C, 240 hours	(1) (2)
Low Temperature Storage Test	-20°C, 240 hours	
Thermal Shock Storage Test	-20°C, 0.5hour←→60°C, 0.5hour; 100cycles, 1hour/cycle	
High Temperature Operation Test	50°C, 240 hours	
Low Temperature Operation Test	0°C, 240 hours	
High Temperature & High Humidity Operation Test	50°C, RH 80%, 240hours	
ESD Test (Operation)	150pF, 330Ω, 1sec/cycle Condition 1 : Contact Discharge, ±8KV Condition 2 : Air Discharge, ±15KV	(1)
Shock (Non-Operating)	220G, 2ms, half sine wave, 1 time for each direction of ±X, ±Y, ±Z	(1)(3)
Vibration (Non-Operating)	1.5G / 10-500 Hz, Sine wave, 30 min/cycle, 1cycle for each X, Y, Z	(1)(3)

Note (1) Criteria: normal display image with no obvious non-uniformity and no line defect.

Note (2) Evaluation should be tested after storage at room temperature for more than two hour

Note (3) At testing Vibration and Shock, the fixture in holding the module has to be hard and rigid enough so that the module would not be twisted or bent by the fixture.

7. PACKING

7.1 MODULE LABEL

The barcode nameplate is pasted on each module as illustration, and its definitions are as following explanation.



(1) Model Number: N133IGE

(2) Serial ID (CMI Internal Use): $Z_1 Z_2 Z_3 Z_4 Z_5 Z_6 - Z_7 - Z_8 Z_9 Z_{10} Z_{11} Z_{12}$

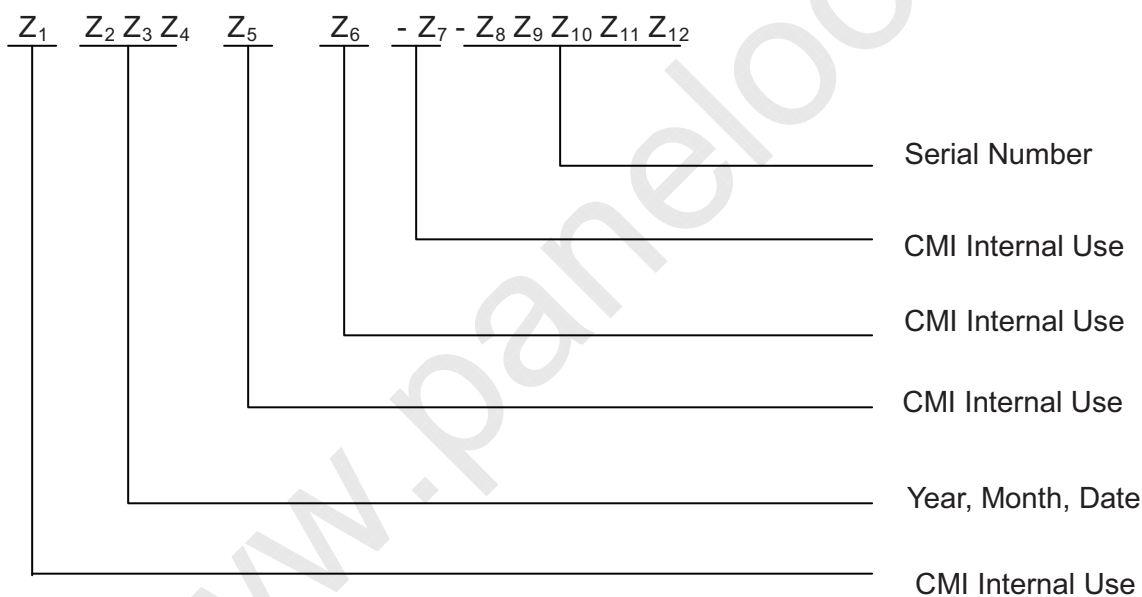

Serial ID includes the information as below:

(a) Manufactured Date:

Year: 0~9, for 2010~2019;

Month: 1~9 & A~C for Jan. ~Dec. ;

Date: 1~9 & A~Z (Exclude I,O,Q,U) for 1st~31st.

(b) Serial Number: Module manufacturing sequence number

7.2 CARTON

Box Dimensions : 425(L)*340(W)*260(H)

Weight: Approx. 12.34kg(25 module ,per. 1 box)

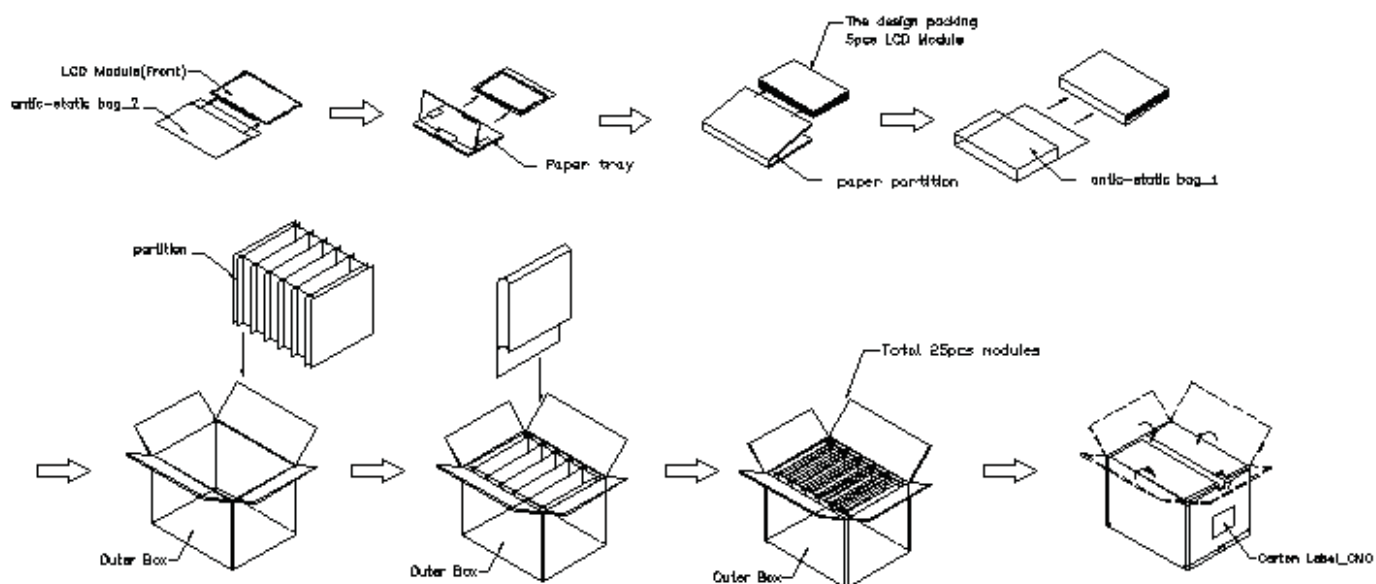

Figure. 7-2 Packing

7.3 PALLET

Sea & Land Transportation

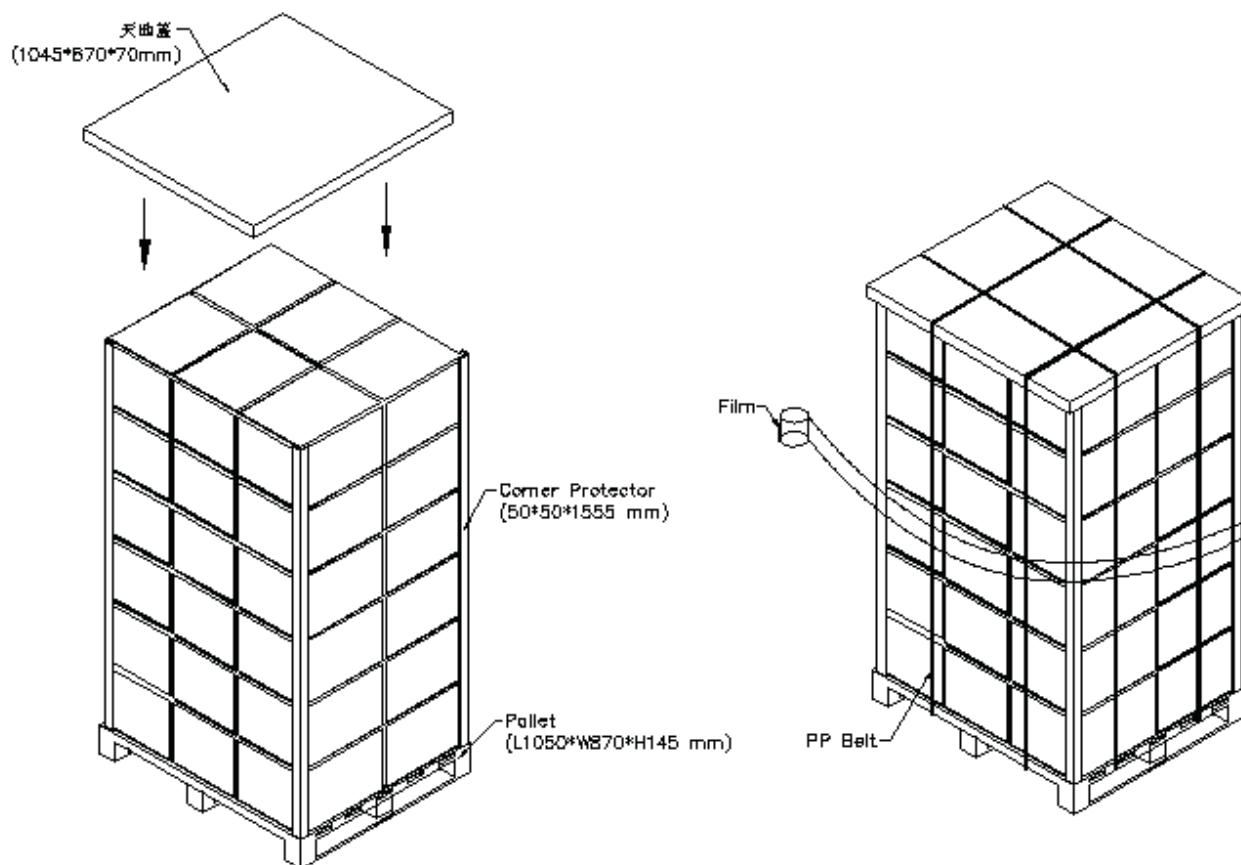

Figure. 7-3 Packing

8. PRECAUTIONS

8.1 HANDLING PRECAUTIONS

- (1) The module should be assembled into the system firmly by using every mounting hole. Be careful not to twist or bend the module.
- (2) While assembling or installing modules, it can only be in the clean area. The dust and oil may cause electrical short or damage the polarizer.
- (3) Use fingerstalls or soft gloves in order to keep display clean during the incoming inspection and assembly process.
- (4) Do not press or scratch the surface harder than a HB pencil lead on the panel because the polarizer is very soft and easily scratched.
- (5) If the surface of the polarizer is dirty, please clean it by some absorbent cotton or soft cloth. Do not use Ketone type materials (ex. Acetone), Ethyl alcohol, Toluene, Ethyl acid or Methyl chloride. It might permanently damage the polarizer due to chemical reaction.
- (6) Wipe off water droplets or oil immediately. Staining and discoloration may occur if they left on panel for a long time.
- (7) If the liquid crystal material leaks from the panel, it should be kept away from the eyes or mouth. In case of contacting with hands, legs or clothes, it must be washed away thoroughly with soap.
- (8) Protect the module from static electricity, it may cause damage to the C-MOS Gate Array IC.
- (9) Do not disassemble the module.
- (10) Do not pull or fold the LED wire.
- (11) Pins of I/F connector should not be touched directly with bare hands.

8.2 STORAGE PRECAUTIONS

- (1) High temperature or humidity may reduce the performance of module. Please store LCD module within the specified storage conditions.
- (2) It is dangerous that moisture come into or contacted the LCD module, because the moisture may damage LCD module when it is operating.
- (3) It may reduce the display quality if the ambient temperature is lower than 10 °C. For example, the response time will become slowly, and the starting voltage of LED will be higher than the room temperature.

8.3 OPERATION PRECAUTIONS

- (1) Do not pull the I/F connector in or out while the module is operating.
- (2) Always follow the correct power on/off sequence when LCD module is connecting and operating. This can prevent the CMOS LSI chips from damage during latch-up.
- (3) Do not disassemble the module or insert anything into the Backlight unit.

Appendix. EDID DATA STRUCTURE

The EDID (Extended Display Identification Data) data formats are to support displays as defined in the VESA Plug & Display and FPD standards.

Byte # (decimal)	Byte # (hex)	Field Name and Comments	Value (hex)	Value (binary)
0	0	Header	00	00000000
1	1	Header	FF	11111111
2	2	Header	FF	11111111
3	3	Header	FF	11111111
4	4	Header	FF	11111111
5	5	Header	FF	11111111
6	6	Header	FF	11111111
7	7	Header	00	00000000
8	8	EISA ID manufacturer name ("APP")	06	00000110
9	9	EISA ID manufacturer name (Compressed ASCII)	10	00010000
10	0A	ID product code (N133IGE)	C9	11001001
11	0B	ID product code (hex LSB first; N133IGE)	9C	10011100
12	0C	ID S/N (fixed "0")	00	00000000
13	0D	ID S/N (fixed "0")	00	00000000
14	0E	ID S/N (fixed "0")	00	00000000
15	0F	ID S/N (fixed "0")	00	00000000
16	10	Week of manufacture (fixed 12 th)	0C	00001100
17	11	Year of manufacture (fixed "2010")	14	00010100
18	12	EDID structure version # ("1")	01	00000001
19	13	EDID revision # ("3")	03	00000011
20	14	Video I/P definition ("digital")	80	10000000
21	15	Max H image size ("29.7cm")	1D	00011101
22	16	Max V image size ("19.2cm")	13	00010011
23	17	Display Gamma (Gamma = "2.2")	78	01111000
24	18	Feature support ("Active off, RGB Color")	0A	00001010
25	19	Red/Green (Rx1, Rx0, Ry1, Ry0, Gx1, Gx0, Gy1, Gy0)	F5	11110101
26	1A	Blue/White (Bx1, Bx0, By1, By0, Wx1, Wx0, Wy1, Wy0)	95	10010101
27	1B	Red-x (Rx = "0.640")	A3	10100011
28	1C	Red-y (Ry = "0.335")	55	01010101
29	1D	Green-x (Gx = "0.310")	4F	01001111
30	1E	Green-y (Gy = "0.610")	9C	10011100
31	1F	Blue-x (Bx = "0.150")	26	00100110
32	20	Blue-y (By = "0.060")	0F	00001111
33	21	White-x (Wx = "0.313")	50	01010000
34	22	White-y (Wy = "0.329")	54	01010100
35	23	Established timings 1	00	00000000
36	24	Established timings 2 (1280x800@60Hz)	00	00000000
37	25	Manufacturer's reserved timings	00	00000000
38	26	Standard timing ID # 1	01	00000001
39	27	Standard timing ID # 1	01	00000001
40	28	Standard timing ID # 2	01	00000001
41	29	Standard timing ID # 2	01	00000001

42	2A	Standard timing ID # 3	01	00000001
43	2B	Standard timing ID # 3	01	00000001
44	2C	Standard timing ID # 4	01	00000001
45	2D	Standard timing ID # 4	01	00000001
46	2E	Standard timing ID # 5	01	00000001
47	2F	Standard timing ID # 5	01	00000001
48	30	Standard timing ID # 6	01	00000001
49	31	Standard timing ID # 6	01	00000001
50	32	Standard timing ID # 7	01	00000001
51	33	Standard timing ID # 7	01	00000001
52	34	Standard timing ID # 8	01	00000001
53	35	Standard timing ID # 8	01	00000001
54	36	Detailed timing description # 1 Pixel clock ("72.5MHz", According to VESA CVT Rev1.1)	52	01010010
55	37	# 1 Pixel clock (hex LSB first)	1C	00011100
56	38	# 1 H active ("1280")	00	00000000
57	39	# 1 H blank ("160")	A0	10100000
58	3A	# 1 H active : H blank ("1280 : 160")	50	01010000
59	3B	# 1 V active ("800")	20	00100000
60	3C	# 1 V blank ("23")	17	00010111
61	3D	# 1 V active : V blank ("800 :23")	30	00110000
62	3E	# 1 H sync offset ("48")	30	00110000
63	3F	# 1 H sync pulse width ("32")	20	00100000
64	40	# 1 V sync offset : V sync pulse width ("3 : 6")	36	00110110
65	41	# 1 H sync offset : H sync pulse width : V sync offset : V sync width ("48: 32 : 3 : 6")	00	00000000
66	42	# 1 H image size ("286.08 mm")	1E	00011110
67	43	# 1 V image size ("178.8 mm")	B2	10110010
68	44	# 1 H image size : V image size ("286 : 178")	10	00010000
69	45	# 1 H boarder ("0")	00	00000000
70	46	# 1 V boarder ("0")	00	00000000
71	47	# 1 Non-interlaced, Normal, no stereo, Separate sync, H/V pol Negatives	18	00011000
72	48	Detailed timing/monitor	00	00000000
73	49	descriptor #2	00	00000000
74	4A		00	00000000
75	4B		01	00000001
76	4C	Version	00	00000000
77	4D	Apple edid signature	06	00000110
78	4E	Apple edid signature	10	00010000
79	4F	Link Type (LVDS Link,MSB justified)	20	00100000
80	50	Pixel and link component format (6-bit panel interface)	00	00000000
81	51	Panel features (No inverter)	00	00000000
82	52		00	00000000
83	53		00	00000000
84	54		00	00000000
85	55		00	00000000
86	56		00	00000000

87	57		00	00000000
88	58		0A	00001010
89	59		20	00100000
90	5A	Detailed timing description # 3	00	00000000
91	5B	# 3 Flag	00	00000000
92	5C	# 3 Reserved	00	00000000
93	5D	# 3 FE (hex) defines ASCII string (Model Name "N133I6-L10", ASCII)	FE	11111110
94	5E	# 3 Flag	00	00000000
95	5F	# 3 1st character of name ("N")	4E	01001110
96	60	# 3 2nd character of name ("1")	31	00110001
97	61	# 3 3rd character of name ("3")	33	00110011
98	62	# 3 4th character of name ("3")	33	00110011
99	63	# 3 5th character of name ("1")	49	01001001
100	64	# 3 6th character of name ("G")	47	01000111
101	65	# 3 7th character of name ("E")	45	01000101
102	66	# 3 8th character of name ("-")	2D	00101101
103	67	# 3 9th character of name ("L")	4C	01001100
104	68	# 3 10th character of name ("4")	34	00110100
105	69	# 3 11th character of name ("1")	31	00110001
106	6A	# 3 New line character indicates end of ASCII string	0A	00001010
107	6B	# 3 Padding with "Blank" character	20	00100000
108	6C	Detailed timing description # 4	00	00000000
109	6D	# 4 Flag	00	00000000
110	6E	# 4 Reserved	00	00000000
111	6F	# 4 FC (hex) defines Monitor name ("Color LCD", ASCII)	FC	11111100
112	70	# 4 Flag	00	00000000
113	71	# 4 1st character of name ("C")	43	01000011
114	72	# 4 2nd character of name ("o")	6F	01101111
115	73	# 4 3rd character of name ("l")	6C	01101100
116	74	# 4 4th character of name ("o")	6F	01101111
117	75	# 4 5th character of name ("r")	72	01110010
118	76	# 4 6th character of name (<space>)	20	00100000
119	77	# 4 7th character of name ("L")	4C	01001100
120	78	# 4 8th character of name ("C")	43	01000011
121	79	# 4 9th character of name ("D")	44	01000100
122	7A	# 4 New line character # 4 indicates end of Monitor name	0A	00001010
123	7B	# 4 Padding with "Blank" character	20	00100000
124	7C	# 4 Padding with "Blank" character	20	00100000
125	7D	# 4 Padding with "Blank" character	20	00100000
126	7E	Extension flag	00	00000000
127	7F	Checksum	23	00100011

Appendix. OUTLINE DRAWING

