

# TFT LCD Approval Specification

## MODEL NO.: N140A1 - L02

Customer: HP

Approved by:

Note:

Liquid Crystal Display Division	
QRA Division.	OA Head Division.
Approval	Approval

**- CONTENTS -****REVISION HISTORY****1. GENERAL DESCRIPTION**

- 1.1 OVERVIEW
- 1.2 FEATURES
- 1.3 APPLICATION
- 1.4 GENERAL SPECIFICATIONS
- 1.5 MECHANICAL SPECIFICATIONS

**2. ABSOLUTE MAXIMUM RATINGS**

- 2.1 ABSOLUTE RATINGS OF ENVIRONMENT
- 2.2 ELECTRICAL ABSOLUTE RATINGS
  - 2.2.1 TFT LCD MODULE
  - 2.2.2 BACKLIGHT UNIT

**3. ELECTRICAL CHARACTERISTICS**

- 3.1 TFT LCD MODULE
- 3.2 BACKLIGHT UNIT

**4. BLOCK DIAGRAM**

- 4.1 TFT LCD MODULE
- 4.2 BACKLIGHT UNIT

**5. INPUT TERMINAL PIN ASSIGNMENT**

- 5.1 TFT LCD MODULE
- 5.2 BACKLIGHT UNIT
- 5.3 TIMING DIAGRAM OF LVDS INPUT SIGNAL
- 5.4 COLOR DATA INPUT ASSIGNMENT
- 5.5 EDID DATA STRUCTURE

**6. INTERFACE TIMING**

- 6.1 INPUT SIGNAL TIMING SPECIFICATIONS
- 6.2 POWER ON/OFF SEQUENCE

**7. OPTICAL CHARACTERISTICS**

- 7.1 TEST CONDITIONS
- 7.2 OPTICAL SPECIFICATIONS

**8. PRECAUTIONS**

- 8.1 ASSEMBLY AND HANDLING PRECAUTIONS
- 8.2 SAFETY PRECAUTIONS

**9. DEFINITION OF LABELS**

- 9.1 CMO MODULE LABEL
- 9.2 CMO CARTON LABEL

**10. PACKAGING**

- 10.1 Packing Specification
- 10.2 Packing Method

**REVISION HISTORY**

Version	Date	Page (New)	Section	Description
3.0	01,13,'05	All	All	Approval spec was first issued
3.1	02,21,'05	last		Add CCFL cable's Kapton tape in outline drawing.

## 1. GENERAL DESCRIPTION

### 1.1 OVERVIEW

N140A1 - L02 is a 14.0" TFT Liquid Crystal Display module with single CCFL Backlight unit and 30 pins LVDS interface. This module supports 1280 x 768 XGA mode and can display 262,144 colors. The optimum viewing angle is at 6 o'clock direction. The inverter module for Backlight is not built in.

### 1.2 FEATURES

- Thin and Light Weight
- XGA (1280 x 768 pixels) resolution
- DE only mode
- 3.3V LVDS (Low Voltage Differential Signaling) interface with 1 pixel/clock

### 1.3 APPLICATION

- TFT LCD Notebook

### 1.4 GENERAL SPECIFICATIONS

Item	Specification	Unit	Note
Active Area	305.28(H) X 183.168(V)	mm	(1)
Bezel Opening Area	308.48 (H) x 186.37 (V)	mm	
Driver Element	a-si TFT active matrix	-	-
Pixel Number	1280 x R.G.B. x 768	pixel	-
Pixel Pitch	0.2385 (H) x 0.2385 (V)	mm	-
Pixel Arrangement	RGB vertical stripe	-	-
Display Colors	262,144	color	-
Transmissive Mode	Normally white	-	-
Surface Treatment	Hard coating (2H), Glare type	-	-

### 1.5 MECHANICAL SPECIFICATIONS

Item	Min.	Typ.	Max.	Unit	Note	
Module Size	Horizontal(H)	315.5	320	320.5	mm	(1)
	Vertical(V)	198.7	199	199.3	mm	
	Depth(D)	--	5.2	5.5	mm	
Weight	--	420	435	g	-	

Note (1) Please refer to the attached drawings for more information of front and back outline dimensions.

## 2. ABSOLUTE MAXIMUM RATINGS

### 2.1 ABSOLUTE RATINGS OF ENVIRONMENT

Item	Symbol	Value		Unit	Note
		Min.	Max.		
Storage Temperature	T <sub>ST</sub>	-20	+60	°C	(1)
Operating Ambient Temperature	T <sub>OP</sub>	0	+50	°C	(1), (2)
Shock (Non-Operating)	S <sub>NOP</sub>	-	200	G	(3), (5)
Vibration (Non-Operating)	V <sub>NOP</sub>	-	2.0	G	(4), (5)

Note (1) Temperature and relative humidity range is shown in the figure below.

(a) 90 %RH Max. ( $T_a \leq 40$  °C).

(b) Wet-bulb temperature should be 39 °C Max. ( $T_a > 40$  °C).

(c) No condensation.

Note (2) The ambient temperature means the temperature of panel surface.

Note (3) 2ms, half sine wave, 1 times for  $\pm X$ ,  $\pm Y$ ,  $\pm Z$ .

Note (4) 10 ~ 500 ~ 10 Hz, Sweep rate 10min, 30min for X, Y, Z. The fixing condition is shown as below:

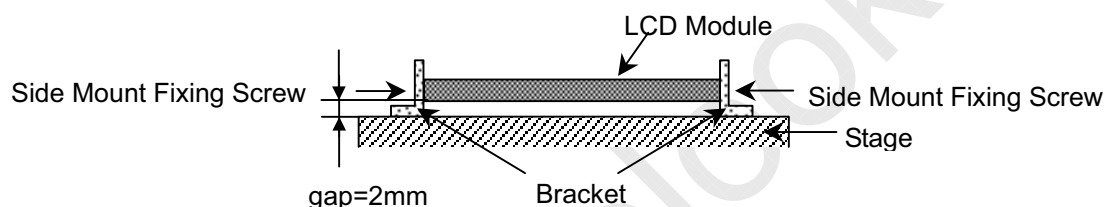

Note (5) At testing Vibration and Shock, the fixture in holding the module has to be hard and rigid enough so that the module would not be twisted or bent by the fixture.

### Relative Humidity (%RH)

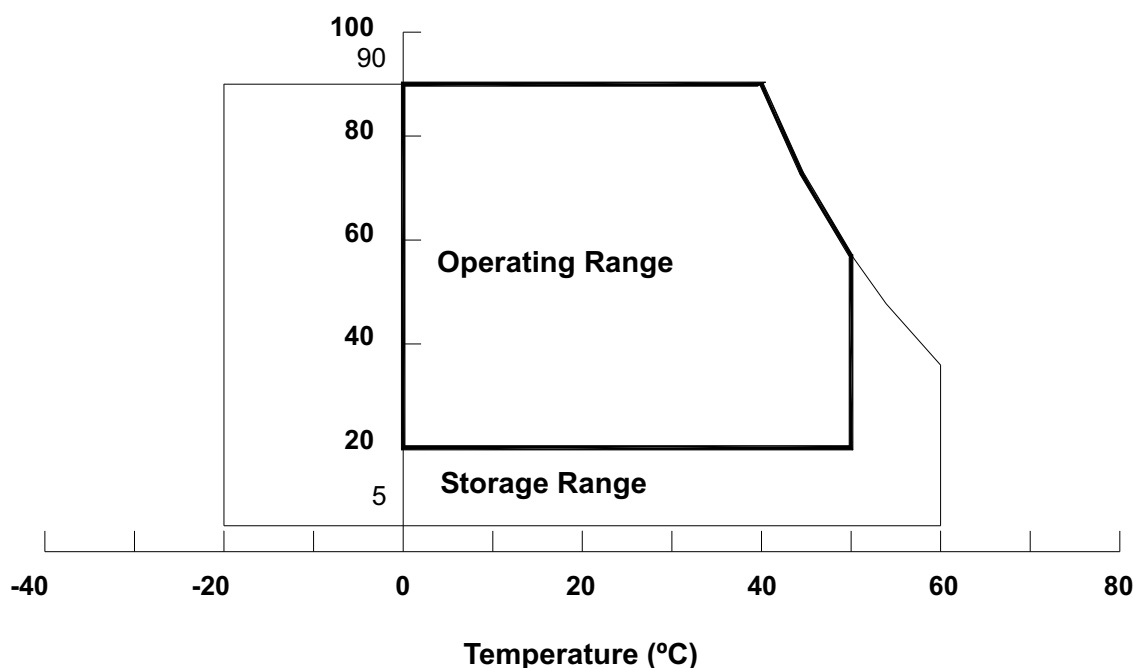

## 2.2.1 TFT LCD MODULE

Item	Symbol	Value		Unit	Note
		Min.	Max.		
Power Supply Voltage	$V_{CC}$	-0.3	+4.0	V	(1)
Logic Input Voltage	$V_{IN}$	-0.3	$V_{CC}+0.3$	V	

## 2.2.2 BACKLIGHT UNIT

Item	Symbol	Value		Unit	Note
		Min.	Max.		
Lamp Voltage	$V_L$	-	2.5K	$V_{RMS}$	(1), (2), $I_L = 6.0 \text{ mA}$
Lamp Current	$I_L$	-	7.5	$\text{mA}_{RMS}$	(1), (2)
Lamp Frequency	$F_L$	-	80	KHz	

Note (1) Permanent damage to the device may occur if maximum values are exceeded. Function operation should be restricted to the conditions described under Normal Operating Conditions.

Note (2) Specified values are for lamp (Refer to 3.2 for further information).

## 3. ELECTRICAL CHARACTERISTICS

## 3.1 TFT LCD MODULE

 $T_a = 25 \pm 2 \text{ }^\circ\text{C}$ 

Parameter	Symbol	Value			Unit	Note	
		Min.	Typ.	Max.			
Power Supply Voltage	$V_{CC}$	3.0	3.3	3.6	V	-	
Ripple Voltage	$V_{RP}$	-	-	100	mV	-	
Rush Current	$I_{RUSH}$	-	-	1.5	A	(2)	
Power Supply Current	White	$I_{CC}$	-	300	340	mA	(3)a
	Black		-	360	410	mA	(3)b
Logical Input Voltage	"H" Level	$V_{IL}$	-	-	+100	mV	-
	"L" Level	$V_{IH}$	-100	-	-	mV	-
Terminating Resistor	$R_T$	-	100	-	Ohm	-	
Power per EBL WG	$P_{EBL}$	-	3.32	-	W	(4)	

Note (1) The module should be always operated within above ranges.

Note (2) Measurement Conditions:

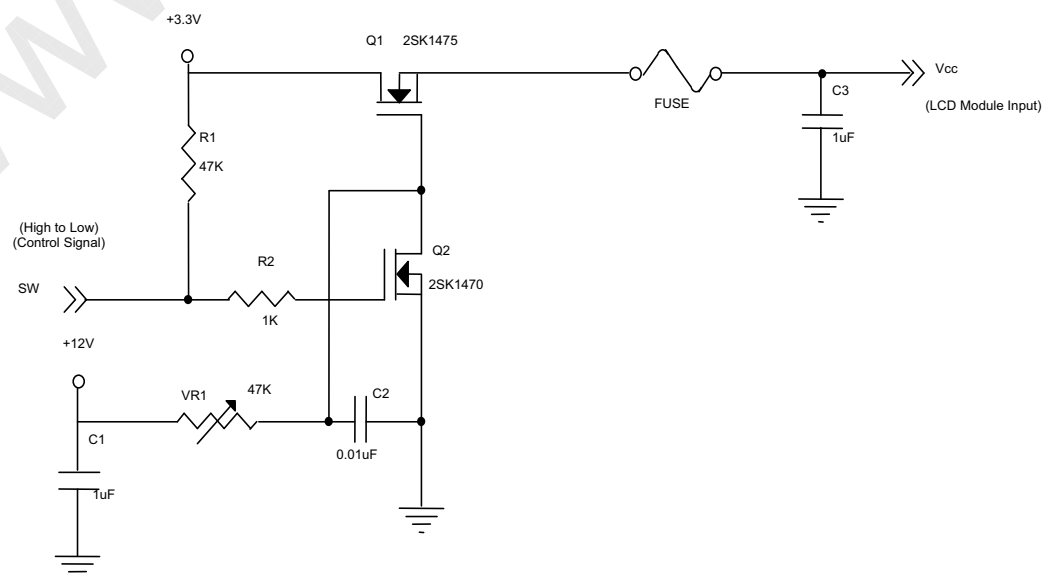

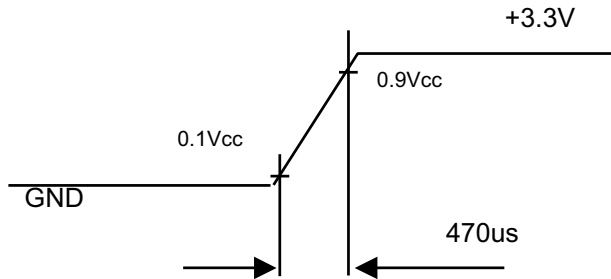
**Vcc rising time is 470us**

Note (3) The specified power supply current is under the conditions at  $V_{cc} = 3.3 \text{ V}$ ,  $T_a = 25 \pm 2 \text{ }^\circ\text{C}$ ,  $f_v = 60 \text{ Hz}$ , whereas a power dissipation check pattern below is displayed.

a. White Pattern



Active Area

b. Black Pattern

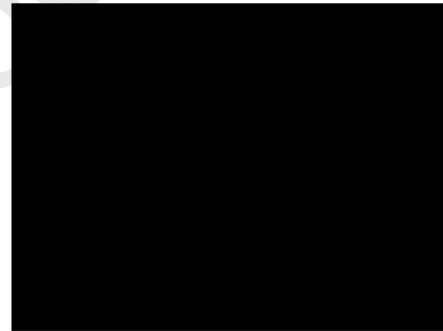

Active Area

Note (4) The specified power are the sum of LCD panel electronics input power and the inverter input power. Test conditions are as follows.

- $V_{cc} = 3.3 \text{ V}$ ,  $T_a = 25 \pm 2 \text{ }^\circ\text{C}$ ,  $f_v = 60 \text{ Hz}$ ,
- The pattern used is a black and white 32 x 36 checkerboard, slide #100 from the VESA file "Flat Panel Display Monitor Setup Patterns", FPDMSU.ppt.
- Luminance: 60 nits.
- The inverter used is provided from [Logah \(www.logah.com\)](http://www.logah.com). Please contact Logah for detail information. CMO doesn't provide the inverter in this product.

## 3.2 BACKLIGHT UNIT

Ta = 25 ± 2 °C

Parameter	Symbol	Value			Unit	Note
		Min.	Typ.	Max.		
Lamp Input Voltage	V <sub>L</sub>	612	680	748	V <sub>RMS</sub>	I <sub>L</sub> = 6.0 mA
Lamp Current	I <sub>L</sub>	2.0	6.0	6.5	mA <sub>RMS</sub>	(1)
Lamp Turn On Voltage	V <sub>s</sub>	---	---	1380 (25 °C)	V <sub>RMS</sub>	(2)
		---	---	1570 (0 °C)	V <sub>RMS</sub>	(2)
Operating Frequency	F <sub>L</sub>	45	---	80	KHz	(3)
Lamp Life Time	L <sub>BL</sub>	10,000	---	---	Hrs	(5)
Power Consumption	P <sub>L</sub>	---	4.08	---	W	(4), I <sub>L</sub> = 6.0 mA

Note (1) Lamp current is measured by utilizing a high frequency current meter as shown below:

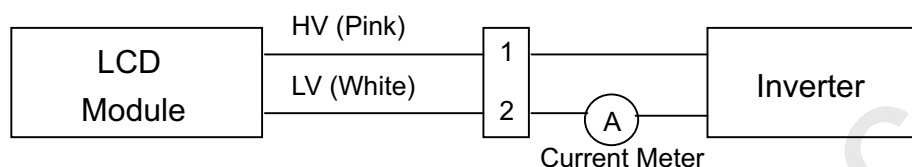

Note (2) The voltage shown above should be applied to the lamp for more than 1 second after startup. Otherwise the lamp may not be turned on.

Note (3) The lamp frequency may produce interference with horizontal synchronous frequency from the display, and this may cause line flow on the display. In order to avoid interference, the lamp frequency should be detached from the horizontal synchronous frequency and its harmonics as far as possible.

Note (4)  $P_L = I_L \times V_L$

Note (5) The lifetime of lamp can be defined as the time in which it continues to operate under the condition Ta = 25 ± 2 °C and I<sub>L</sub> = 6.0 mA<sub>RMS</sub> until one of the following events occurs:

- When the brightness becomes or lower than 50% of its original value.
- When the effective ignition length becomes or lower than 80% of its original value. (Effective ignition length is defined as an area that has less than 70% brightness compared to the brightness in the center point.)

Note (6) The waveform of the voltage output of inverter must be area-symmetric and the design of the inverter must have specifications for the modularized lamp. The performance of the Backlight, such as lifetime or brightness, is greatly influenced by the characteristics of the DC-AC inverter for the lamp. All the parameters of an inverter should be carefully designed to avoid producing too much current leakage from high voltage output of the inverter. When designing or ordering the inverter please make sure that a poor lighting caused by the mismatch of the Backlight and the inverter (miss-lighting, flicker, etc.) never occurs. If the above situation is confirmed, the module should be operated in the same manners when it is installed in your instrument.

The output of the inverter must have symmetrical (negative and positive) voltage waveform and symmetrical current waveform. (Unsymmetrical ratio is less than 10%) Please do not use the inverter



which has unsymmetrical voltage and unsymmetrical current and spike wave. Lamp frequency may produce interface with horizontal synchronous frequency and as a result this may cause beat on the display. Therefore lamp frequency shall be as away possible from the horizontal synchronous frequency and from its harmonics in order to prevent interference.

Requirements for a system inverter design, which is intended to have a better display performance, a better power efficiency and a more reliable lamp. It shall help increase the lamp lifetime and reduce its leakage current.

- The asymmetry rate of the inverter waveform should be 10% below.
- The distortion rate of the waveform should be within  $\sqrt{2} \pm 10\%$ .
- The ideal sine wave form shall be symmetric in positive and negative polarities.

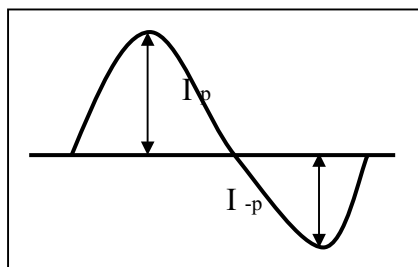

\* Asymmetry rate:

$$|I_p - I_{-p}| / I_{rms} * 100\%$$

\* Distortion rate

$$I_p \text{ (or } I_{-p}) / I_{rms}$$

## 4. BLOCK DIAGRAM

### 4.1 TFT LCD MODULE

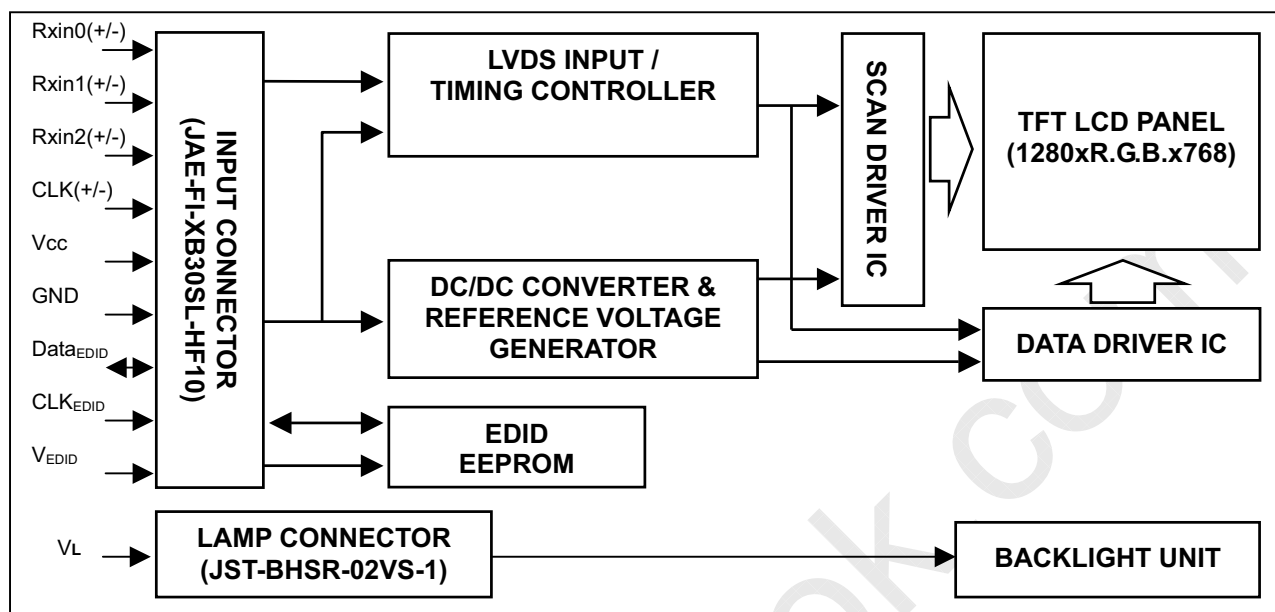

### 4.2 BACKLIGHT UNIT



## 5. INPUT TERMINAL PIN ASSIGNMENT

### 5.1 TFT LCD MODULE

Pin	Symbol	Description	Polarity	Remark
1	V <sub>ss</sub>	Ground		
2	V <sub>cc</sub>	Power Supply +3.3 V (typical)		
3	V <sub>cc</sub>	Power Supply +3.3 V (typical)		
4	V <sub>EDID</sub>	DDC 3.3V Power		DDC 3.3V Power
5	NC	Non-Connection		
6	CLK <sub>EDID</sub>	DDC Clock		DDC Clock
7	DATA <sub>EDID</sub>	DDC Data		DDC Data
8	Rxin0-	LVDS Differential Data Input	Negative	R0~R5, G0
9	Rxin0+	LVDS Differential Data Input	Positive	-
10	V <sub>ss</sub>	Ground		
11	Rxin1-	LVDS Differential Data Input	Negative	G1~G5, B0, B1
12	Rxin1+	LVDS Differential Data Input	Positive	-
13	V <sub>ss</sub>	Ground		
14	Rxin2-	LVDS Differential Data Input	Negative	B2~B5, DE, Hsync, Vsync

15	Rxin2+	LVDS Differential Data Input	Positive	
16	Vss	Ground		
17	CLK-	LVDS Clock Data Input	Negative	LVDS Level Clock
18	CLK+	LVDS Clock Data Input	Positive	
19	Vss	Ground		
20	NC	Non-Connection		
21	NC	Non-Connection		
22	NC	Non-Connection		
23	NC	Non-Connection		
24	NC	Non-Connection		
25	NC	Non-Connection		
26	NC	Non-Connection		
27	NC	Non-Connection		
28	NC	Non-Connection		
29	NC	Non-Connection		
30	NC	Non-Connection		

Note (1) Connector Part No.: JAE-FI-XB30SL-HF10 or equivalent

Note (2) User's connector Part No: FI-X30C2L or equivalent

Note (3) The first pixel is even.

## 5.2 BACKLIGHT UNIT

Pin	Symbol	Description	Color
1	HV	High Voltage	Pink
2	LV	Ground	White

Note (1) Connector Part No.: JST- BHSR-02VS-1 or equivalent

Note (2) User's connector Part No.: SM02B-BHSS-1-TB or equivalent

## 5.3 TIMING DIAGRAM OF LVDS INPUT SIGNAL

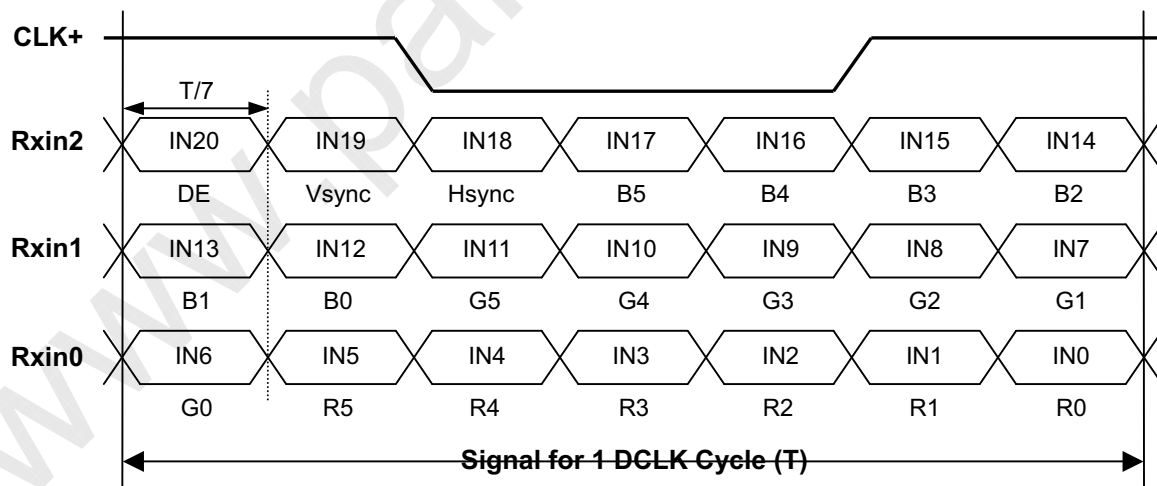

#### 5.4 COLOR DATA INPUT ASSIGNMENT

The brightness of each primary color (red, green and blue) is based on the 6-bit gray scale data input for the color. The higher the binary input, the brighter the color. The table below provides the assignment of color versus data input.

Color		Data Signal																	
		Red						Green						Blue					
		R5	R4	R3	R2	R1	R0	G5	G4	G3	G2	G1	G0	B5	B4	B3	B2	B1	B0
Basic Colors	Black	0	0	0	0	0	0	0	0	0	0	0	0	0	0	0	0	0	0
	Red	1	1	1	1	1	1	0	0	0	0	0	0	0	0	0	0	0	0
	Green	0	0	0	0	0	0	1	1	1	1	1	1	0	0	0	0	0	0
	Blue	0	0	0	0	0	0	0	0	0	0	0	0	1	1	1	1	1	1
	Cyan	0	0	0	0	0	0	1	1	1	1	1	1	1	1	1	1	1	1
	Magenta	1	1	1	1	1	1	0	0	0	0	0	0	0	1	1	1	1	1
	Yellow	1	1	1	1	1	1	1	1	1	1	1	1	0	0	0	0	0	0
	White	1	1	1	1	1	1	1	1	1	1	1	1	1	1	1	1	1	1
Gray Scale Of Red	Red(0)/Dark	0	0	0	0	0	0	0	0	0	0	0	0	0	0	0	0	0	0
	Red(1)	0	0	0	0	0	1	0	0	0	0	0	0	0	0	0	0	0	0
	Red(2)	0	0	0	0	1	0	0	0	0	0	0	0	0	0	0	0	0	0
	:	:	:	:	:	:	:	:	:	:	:	:	:	:	:	:	:	:	:
	:	:	:	:	:	:	:	:	:	:	:	:	:	:	:	:	:	:	:
	:	:	:	:	:	:	:	:	:	:	:	:	:	:	:	:	:	:	:
	Red(61)	1	1	1	1	0	1	0	0	0	0	0	0	0	0	0	0	0	0
	Red(62)	1	1	1	1	1	0	0	0	0	0	0	0	0	0	0	0	0	0
Red(63)	1	1	1	1	1	1	0	0	0	0	0	0	0	0	0	0	0	0	
Gray Scale Of Green	Green(0)/Dark	0	0	0	0	0	0	0	0	0	0	0	0	0	0	0	0	0	0
	Green(1)	0	0	0	0	0	0	0	0	0	0	0	1	0	0	0	0	0	0
	Green(2)	0	0	0	0	0	0	0	0	0	0	1	0	0	0	0	0	0	0
	:	:	:	:	:	:	:	:	:	:	:	:	:	:	:	:	:	:	:
	:	:	:	:	:	:	:	:	:	:	:	:	:	:	:	:	:	:	:
	:	:	:	:	:	:	:	:	:	:	:	:	:	:	:	:	:	:	:
	Green(61)	0	0	0	0	0	0	1	1	1	1	0	1	0	0	0	0	0	0
	Green(62)	0	0	0	0	0	0	1	1	1	1	1	0	0	0	0	0	0	0
Green(63)	0	0	0	0	0	0	1	1	1	1	1	1	0	0	0	0	0	0	
Gray Scale Of Blue	Blue(0)/Dark	0	0	0	0	0	0	0	0	0	0	0	0	0	0	0	0	0	0
	Blue(1)	0	0	0	0	0	0	0	0	0	0	0	0	0	0	0	0	0	1
	Blue(2)	0	0	0	0	0	0	0	0	0	0	0	0	0	0	0	0	1	0
	:	:	:	:	:	:	:	:	:	:	:	:	:	:	:	:	:	:	:
	:	:	:	:	:	:	:	:	:	:	:	:	:	:	:	:	:	:	:
	:	:	:	:	:	:	:	:	:	:	:	:	:	:	:	:	:	:	:
	Blue(61)	0	0	0	0	0	0	0	0	0	0	0	0	1	1	1	1	0	1
	Blue(62)	0	0	0	0	0	0	0	0	0	0	0	0	1	1	1	1	1	0
Blue(63)	0	0	0	0	0	0	0	0	0	0	0	0	1	1	1	1	1	1	

Note (1) 0: Low Level Voltage, 1: High Level Voltage

## 5.5 EDID DATA STRUCTURE

The EDID (Extended Display Identification Data) data formats are to support displays as defined in the VESA Plug & Display and FPD standards.

Byte # (decimal)	Byte # (hex)	Field Name and Comments	Value (hex)	Value (binary)
0	0	Header , Fixed	00	00000000
1	1	Header , Fixed	FF	11111111
2	2	Header , Fixed	FF	11111111
3	3	Header , Fixed	FF	11111111
4	4	Header , Fixed	FF	11111111
5	5	Header , Fixed	FF	11111111
6	6	Header , Fixed	FF	11111111
7	7	Header , Fixed	00	00000000
8	8	EISA Mfg. Code LSB 3 character in compressed ASCII: "CMO" -> 0D AF	0D	00001101
9	9	EISA Mfg. Code LSB 3 character in compressed ASCII: "CMO" -> 0D AF	AF	10101111
10	0A	Product code 1403, (hex, LSB first)	03	00000011
11	0B	Product code 1403, (hex, LSB first)	14	00010100
12	0C	32-bit serial # Unused(01h for VESA, 00h for SPWG)	00	00000000
13	0D	32-bit serial # Unused(01h for VESA, 00h for SPWG)	00	00000000
14	0E	32-bit serial # Unused(01h for VESA, 00h for SPWG)	00	00000000
15	0F	32-bit serial # Unused(01h for VESA, 00h for SPWG)	00	00000000
16	10	Week of manufacture 1 - 53 (unused: 00h) : 02h fixed by CMO	02	00000010
17	11	Year of manufacture year - 1990(used:00h) : 0Dh (Year 2004) fixed by CMO	0D	00001101
18	12	Version=1	01	00000001
19	13	Revision=3	03	00000011
20	14	Digital	80	10000000
21	15	Active area horizontal 30.53cm	1F	00011111
22	16	Active area vertical 18.32cm	12	00010010
23	17	gamma * 100-100 = 2.2*100-100=120	78	01111000
24	18	Feature support (no DPMS, Active off, RGB, Preferred Timing Mode)	0A	00001010
25	19	Rx1 Rx0 Ry1 Ry0 Gx1 Gx0 Gy1 Gy0	E0	11100000
26	1A	Bx1 Bx0 By1 By0 Wx1 Wx0 Wy1 Wy0	D5	11010101
27	1B	Rx=0.589	96	10010110
28	1C	Ry=0.338	56	01010110
29	1D	Gx=0.320	52	01010010
30	1E	Gy=0.535	89	10001001
31	1F	Bx=0.155	27	00100111
32	20	By=0.134	22	00100010
33	21	Wx=0.313	50	01010000
34	22	Wy=0.329	54	01010100
35	23	Not supported	00	00000000
36	24	Not supported	00	00000000
37	25	No manufacturer's specific timing	00	00000000
Byte #	Byte #	Field Name and Comments	Value	Value

(decimal)	(hex)		(hex)	(binary)
38	26	01h: Blank	01	00000001
39	27	01h: Blank	01	00000001
40	28	01h: Blank	01	00000001
41	29	01h: Blank	01	00000001
42	2A	01h: Blank	01	00000001
43	2B	01h: Blank	01	00000001
44	2C	01h: Blank	01	00000001
45	2D	01h: Blank	01	00000001
46	2E	01h: Blank	01	00000001
47	2F	01h: Blank	01	00000001
48	30	01h: Blank	01	00000001
49	31	01h: Blank	01	00000001
50	32	01h: Blank	01	00000001
51	33	01h: Blank	01	00000001
52	34	01h: Blank	01	00000001
53	35	01h: Blank	01	00000001
54	36	Pixel clock/10000(LSB first)	BC	10111100
55	37	71MHz/10000 = 7100 = 1BBCh	1B	00011011
56	38	HActive(D7-D0) = 1280 mod 256	00	00000000
57	39	HBlank(D7-D0) = 160 mod 256	A0	10100000
58	3A	HActive(D11-D8) : HBlank(D11-D8) = 1280/256 : 160/256	50	01010000
59	3B	VActive(D7-D0) = 768 mod 256	00	00000000
60	3C	VBlank(D7-D0) = 55 mod 256	37	00110111
61	3D	VActive(D11-D8) : VBlank(D11-D8) = 768/256 : 55/256	30	00110000
62	3E	HSyncOffset(D7-D0) = HBorder+HFrontPorch = 48	30	00110000
63	3F	HSyncWidth(D7-D0) = 32	20	00100000
64	40	VSynOffset(D3-D0) : VSynWidth(D3-D0)	36	00110110
65	41	H sync offset : H sync pulse width : V sync offset : V sync width (" 48 : 32 : 3 : 6" )	00	00000000
66	42	HImageSize(mm, D7-D0) = 305 mod 256	31	00110001
67	43	VImageSize(mm, D7-D0) = 183 mod 256	B7	10110111
68	44	HImageSize(D11-D8) : VImageSize(D11-D8) = 305/256 : 183/256	10	00010000
69	45	Hborder=0	00	00000000
70	46	Vborder=0	00	00000000
71	47	Non-interlaced, Normal Display, Digital separate	18	00011000
72	48	Detailed timing description # 2	00	00000000
73	49	# 2 Flag	00	00000000
74	4A	# 2 Reserved	00	00000000
75	4B	# 2 FE (hex) defines ASCII string (Model Name "N140A1", ASCII)	FE	11111110
76	4C	# 2 Flag	00	00000000
77	4D	# 2 1 <sup>st</sup> character of string ("N")	4E	01001110
78	4E	# 2 2 <sup>nd</sup> character of string ("1")	31	00110001
79	4F	# 2 3 <sup>rd</sup> character of string ("4")	34	00110100
80	50	# 2 4 <sup>th</sup> character of string ("0")	30	00110000
81	51	# 2 5 <sup>th</sup> character of string ("A")	41	01000001
Byte #	Byte #	Field Name and Comments	Value	Value

(decimal)	(hex)		(hex)	(binary)
82	52	# 2 6 <sup>th</sup> character of string ("1")	31	00110001
83	53	# 2 New line character # 2 indicates end of ASCII string	0A	00001010
84	54	# 2 Padding with "Blank" character	20	00100000
85	55	# 2 Padding with "Blank" character	20	00100000
86	56	# 2 Padding with "Blank" character	20	00100000
87	57	# 2 Padding with "Blank" character	20	00100000
88	58	# 2 Padding with "Blank" character	20	00100000
89	59	# 2 Padding with "Blank" character	20	00100000
90	5A	Detailed timing description # 3	00	00000000
91	5B	# 3 Flag	00	00000000
92	5C	# 3 Reserved	00	00000000
93	5D	# 3 FE (hex) defines ASCII string (Vendor "CMO", ASCII)	FE	11111110
94	5E	# 3 Flag	00	00000000
95	5F	# 3 1 <sup>st</sup> character of string ("C")	43	01000011
96	60	# 3 2 <sup>nd</sup> character of string ("M")	4D	01001101
97	61	# 3 3 <sup>rd</sup> character of string ("O")	4F	01001111
98	62	# 3 New line character # 3 indicates end of ASCII string	0A	00001010
99	63	# 3 Padding with "Blank" character	20	00100000
100	64	# 3 Padding with "Blank" character	20	00100000
101	65	# 3 Padding with "Blank" character	20	00100000
102	66	# 3 Padding with "Blank" character	20	00100000
103	67	# 3 Padding with "Blank" character	20	00100000
104	68	# 3 Padding with "Blank" character	20	00100000
105	69	# 3 Padding with "Blank" character	20	00100000
106	6A	# 3 Padding with "Blank" character	20	00100000
107	6B	# 3 Padding with "Blank" character	20	00100000
108	6C	Detailed timing description # 4	00	00000000
109	6D	# 4 Flag	00	00000000
110	6E	# 4 Reserved	00	00000000
111	6F	# 4 FC (hex) defines Monitor name (Model Name"N140A1-L01", ASCII)	FC	11111100
112	70	# 4 Flag	00	00000000
113	71	# 4 1 <sup>st</sup> character of name ("N")	4E	01001110
114	72	# 4 2 <sup>nd</sup> character of name ("1")	31	00110001
115	73	# 4 3 <sup>rd</sup> character of name ("4")	34	00110100
116	74	# 4 4 <sup>th</sup> character of name ("0")	30	00110000
117	75	# 4 5 <sup>th</sup> character of name ("A")	41	01000001
118	76	# 4 6 <sup>th</sup> character of name ("1")	31	00110001
119	77	# 4 7 <sup>th</sup> character of name ("-")	2D	00101101
120	78	# 4 8 <sup>th</sup> character of name ("L")	4C	01001100
121	79	# 4 9 <sup>th</sup> character of name ("0")	30	00110000
122	7A	# 4 9 <sup>th</sup> character of name ("1")	31	00110001
123	7B	# 4 New line character # 4 indicates end of ASCII string	0A	00001010
124	7C	# 4 Padding with "Blank" character	20	00100000
125	7D	# 4 Padding with "Blank" character	20	00100000
126	7E	Extension flag	00	00000000
127	7F	One-byte checksum of entire 128 bytes EDID equals 00h.	17	00010111

## 6. INTERFACE TIMING

### 6.1 INPUT SIGNAL TIMING SPECIFICATIONS

The specifications of input signal timing are as the following table and timing diagram.

Signal	Item	Symbol	Min.	Typ.	Max.	Unit	Note
DCLK	Frequency	1/Tc	50	68.25	80	MHz	-
DE	Vertical Total Time	TV	778	790	2000	TH	-
	Vertical Addressing Time	TVD	768	768	768	TH	-
	Horizontal Total Time	TH	1350	1440	1900	Tc	-
	Horizontal Addressing Time	THD	1280	1280	1280	Tc	-

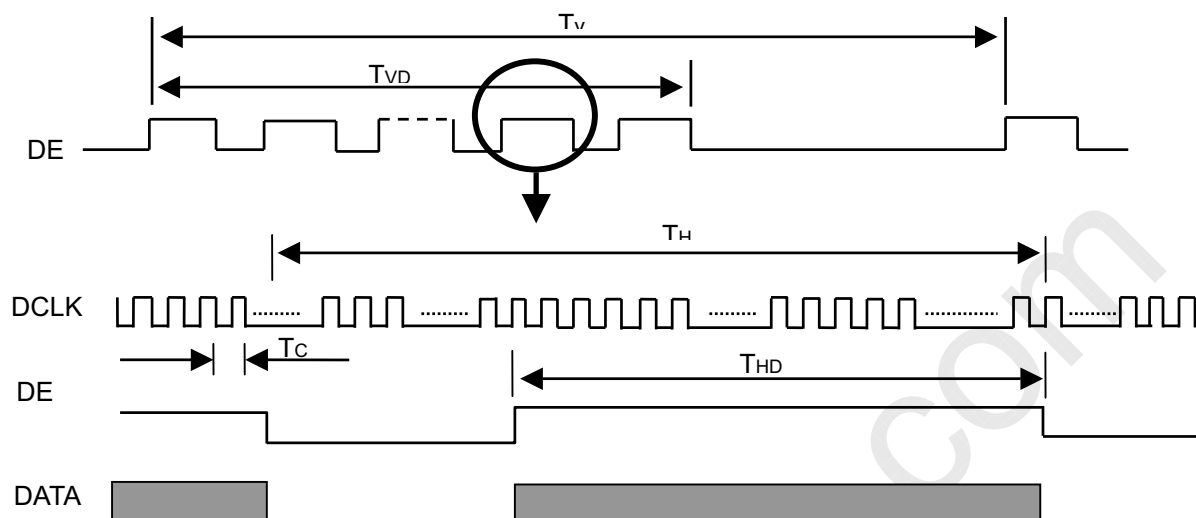
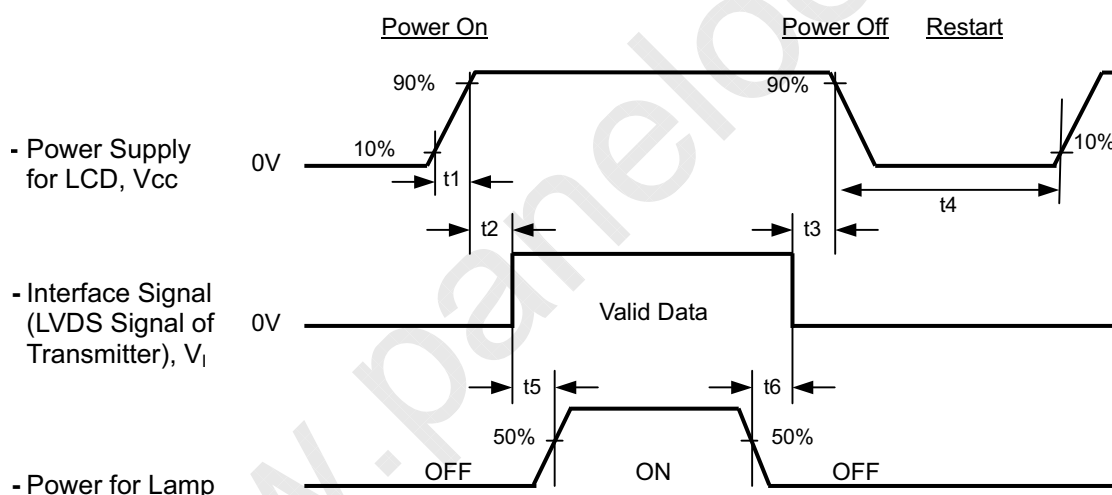

**INPUT SIGNAL TIMING DIAGRAM****6.2 POWER ON/OFF SEQUENCE****Timing Specifications:**

$$0.5 < t_1 \leq 10 \text{ msec}$$

$$0 < t_2 \leq 50 \text{ msec}$$

$$0 < t_3 \leq 50 \text{ msec}$$

$$t_4 \geq 500 \text{ msec}$$

$$t_5 \geq 200 \text{ msec}$$

$$t_6 \geq 200 \text{ msec}$$

Note (1) Please avoid floating state of interface signal at invalid period.

Note (2) When the interface signal is invalid, be sure to pull down the power supply of LCD V<sub>cc</sub> to 0 V.

Note (3) The Backlight inverter power must be turned on after the power supply for the logic and the interface signal is valid. The Backlight inverter power must be turned off before the power supply for the logic and the interface signal is invalid.

Note (4) Sometimes some slight noise shows when LCD is turned off (even backlight is already off). To avoid this phenomenon, we suggest that the Vcc falling time had better to follow

$$t7 \geq 5 \text{ msec}$$

## 7. OPTICAL CHARACTERISTICS

### 7.1 TEST CONDITIONS

Item	Symbol	Value	Unit
Ambient Temperature	Ta	25±2	°C
Ambient Humidity	Ha	50±10	%RH
Supply Voltage	V <sub>CC</sub>	3.3	V
Input Signal	According to typical value in "3. ELECTRICAL CHARACTERISTICS"		
Inverter Current	I <sub>L</sub>	6	mA
Inverter Driving Frequency	F <sub>L</sub>	55	KHz
Inverter	H05-4915		

The relative measurement methods of optical characteristics are shown in 6.2. The following items should be measured under the test conditions described in 6.1 and stable environment shown in Note (6).

### 7.2 OPTICAL SPECIFICATIONS

Item		Symbol	Condition	Min.	Typ.	Max.	Unit	Note
Response Time		T <sub>R</sub>	$\theta_x=0^\circ, \theta_y=0^\circ$	-	5	10	ms	(3)
		T <sub>F</sub>		-	11	16	ms	
White Variation		$\delta W$	$\theta_x=0^\circ, \theta_y=0^\circ$	-	-	1.4	-	(6), (7)
Cross Talk		CT	BM-5A	-	-	3.0	%	(5), (6)
Center Luminance of White		L	$\theta_x=0^\circ, \theta_y=0^\circ$ CS-1000T	160	200	-	cd/m <sup>2</sup>	(4), (6)
Contrast Ratio		CR		250	400	-	-	(2), (6)
Color Chromaticity	Red	R <sub>x</sub>		$\theta_x=0^\circ, \theta_y=0^\circ$ CS-1000T	TYP -0.03	TYP +0.03	-	(1), (6)
		R <sub>y</sub>					0.590	
	Green	G <sub>x</sub>	0.340				-	
		G <sub>y</sub>	0.317				-	
	Blue	B <sub>x</sub>	0.541				-	
		B <sub>y</sub>	0.150				-	
White	W <sub>x</sub>	0.134	-					
	W <sub>y</sub>	0.313	-					
Viewing Angle	Horizontal	$\theta_{x+}$	CR≥10 BM-5A	40	45		Deg.	
		$\theta_{x-}$		40	45			
	Vertical	$\theta_{y+}$		15	20			
		$\theta_{y-}$		40	45			

Note (1) Definition of Viewing Angle ( $\theta_x$ ,  $\theta_y$ ):

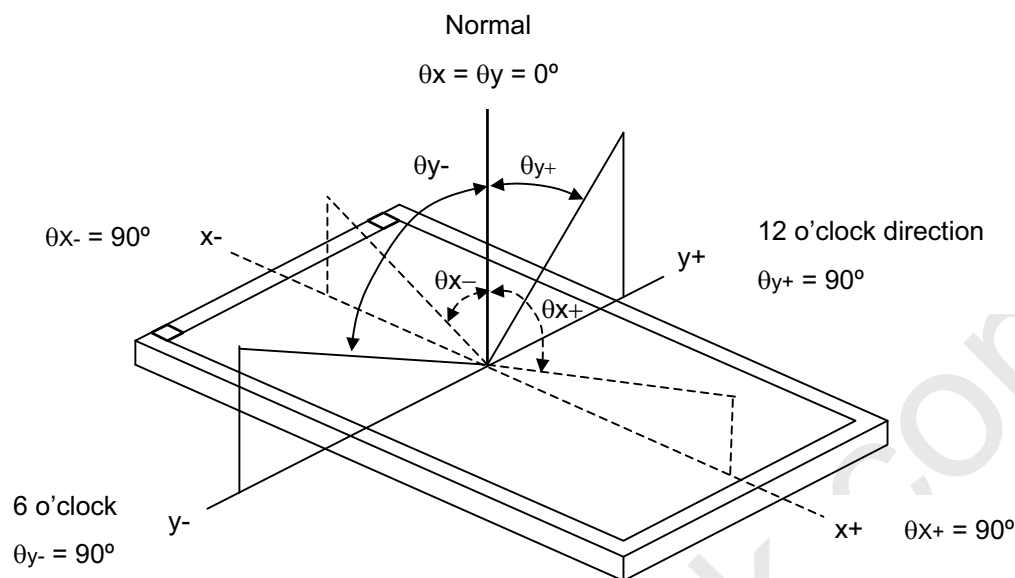

Note (2) Definition of Contrast Ratio (CR):

The contrast ratio can be calculated by the following expression.

$$\text{Contrast Ratio (CR)} = L_{63} / L_0$$

L63: Luminance of gray level 63

L 0: Luminance of gray level 0

$$\text{CR} = \text{CR} (5)$$

CR (X) is corresponding to the Contrast Ratio of the point X at Figure in Note (7).

Note (3) Definition of Response Time ( $T_R$ ,  $T_F$ ) and measurement method:

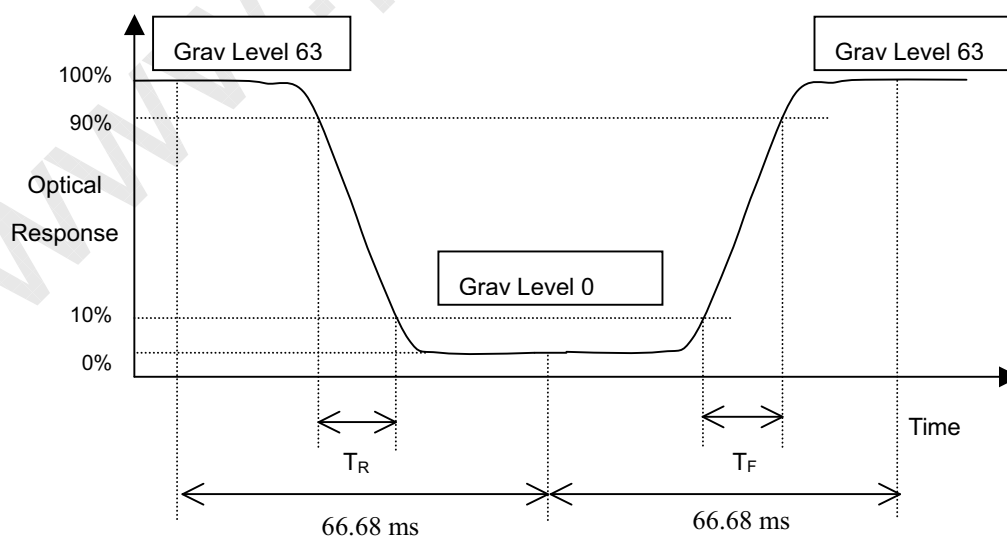

Note (4) Definition of Center Luminance of White (L):

Measure the luminance of gray level 63 at center point

$$L = L(5)$$

L(5) is corresponding to the luminance of the point 5 at Figure in Note (7).

Note (5) Definition of Cross Talk (CT):

$$CT = |Y_B - Y_A| / Y_A \times 100 (\%)$$

Where:

$Y_A$  = Luminance of measured location without gray level 0 pattern ( $\text{cd}/\text{m}^2$ )

$Y_B$  = Luminance of measured location with gray level 0 pattern ( $\text{cd}/\text{m}^2$ )

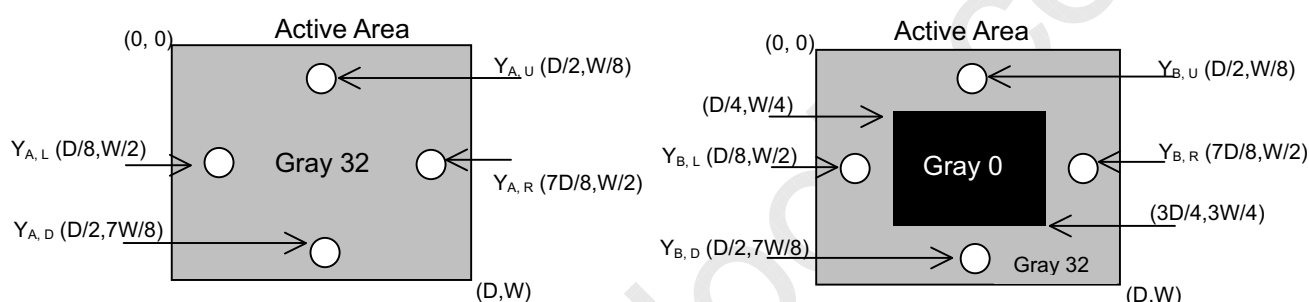

Note (6) Measurement Setup:

The LCD module should be stabilized at given temperature for 20 minutes to avoid abrupt temperature change during measuring. In order to stabilize the luminance, the measurement should be executed after lighting Backlight for 20 minutes in a windless room.

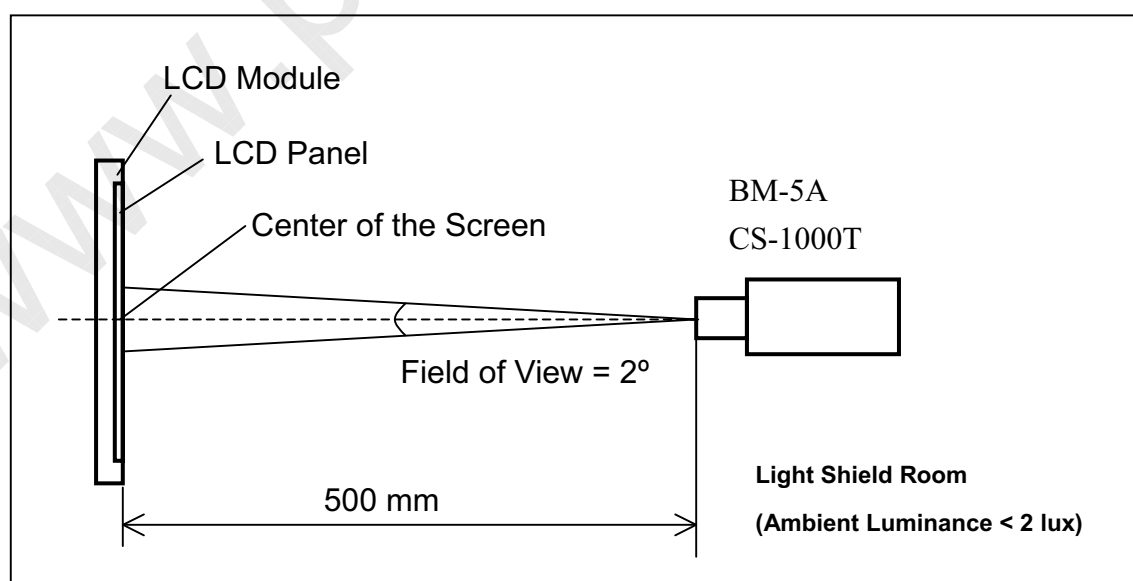

Note (7) Definition of White Variation ( $\delta W$ ):

Measure the luminance of gray level 63 at 5 points

$$\delta W = \text{Maximum [L (1), L (2), L (3), L (4), L (5)]} / \text{Minimum [L (1), L (2), L (3), L (4), L (5)]}$$

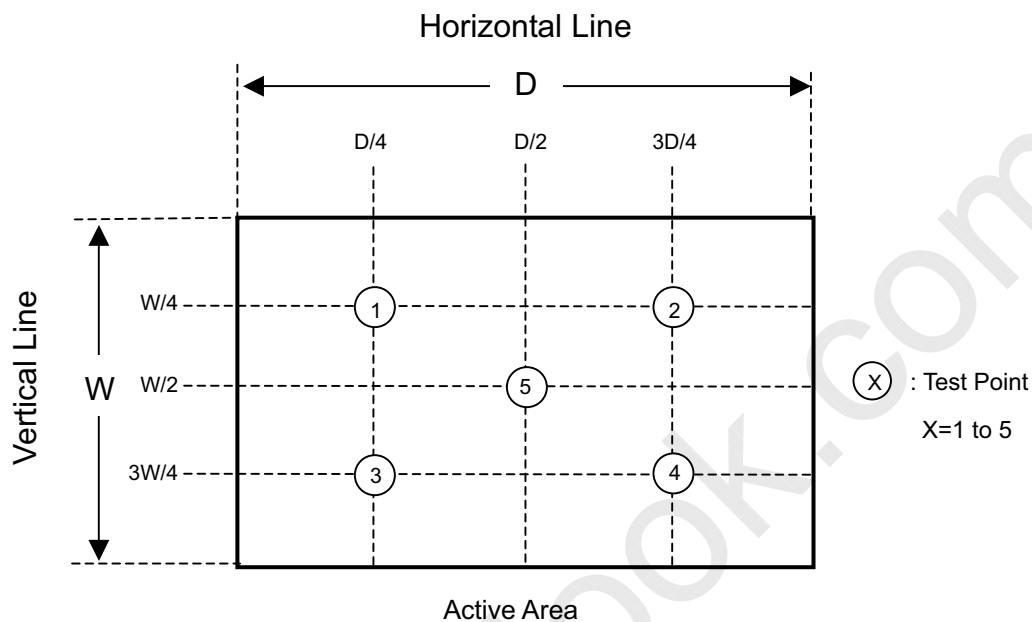

## 8. PRECAUTIONS

### 8.1 ASSEMBLY AND HANDLING PRECAUTIONS

- (1) Do not apply rough force such as bending or twisting to the module during assembly.
- (2) To assemble or install module into user's system can be only in clean working areas. The dust and oil may cause electrical short or worsen the polarizer.
- (3) It's not permitted to have pressure or impulse on the module because the LCD panel and Backlight will be damaged.
- (4) Always follow the correct power sequence when LCD module is connecting and operating. This can prevent damage to the CMOS LSI chips during latch-up.
- (5) Do not pull the I/F connector in or out while the module is operating.
- (6) Do not disassemble the module.
- (7) Use a soft dry cloth without chemicals for cleaning, because the surface of polarizer is very soft and easily scratched.
- (8) It is dangerous that moisture come into or contacted the LCD module, because moisture may damage LCD module when it is operating.
- (9) High temperature or humidity may reduce the performance of module. Please store LCD module within the specified storage conditions.
- (10) When ambient temperature is lower than 10°C may reduce the display quality. For example, the response time will become slowly, and the starting voltage of CCFL will be higher than room temperature.

### 8.2 SAFETY PRECAUTIONS

- (1) The startup voltage of Backlight is approximately 1000 Volts. It may cause electrical shock while assembling with inverter. Do not disassemble the module or insert anything into the Backlight unit.
- (2) If the liquid crystal material leaks from the panel, it should be kept away from the eyes or mouth. In case of contact with hands, skin or clothes, it has to be washed away thoroughly with soap.
- (3) After the module's end of life, it is not harmful in case of normal operation and storage.

## 9. DEFINITION OF LABELS

### 9.1 CMO MODULE LABEL

The barcode nameplate is pasted on each module as illustration, and its definitions are as following explanation.



(a) Model Name: N140A1 - L02

(b) Revision: Rev. XX: ES : A1, A2, A3,..., etc.

CS & MP : C1, C2, C3,...,etc.

Note: It will happen that revision code changed without product changed in developing duration because of CMO internal stage change, for example: AX → B1, BX → C1.

(c) Serial ID: XXXXXXXXYMDLNNNN

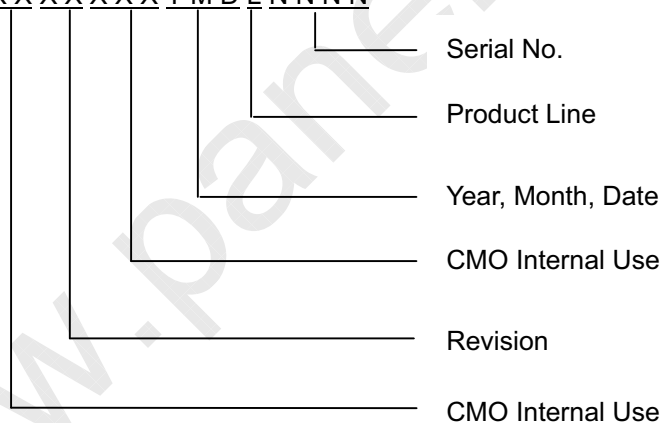

Serial ID includes the information as below:

(a) Manufactured Date: Year: 0 ~ 9, for 2000 ~ 2009.

Month: 1 ~ 9, A ~ C, for Jan. ~ Dec.

Day: 1 ~ 9, A ~ Y, for 1<sup>st</sup> to 31<sup>st</sup>, exclude I, O and U.

(b) Revision Code: cover all the changes.

(c) Serial No.: Manufacturing sequence of product.

(d) Product Line: 1 -> Line1, 2 -> Line 2, ...etc.

## 9.2 CMO CARTON LABEL

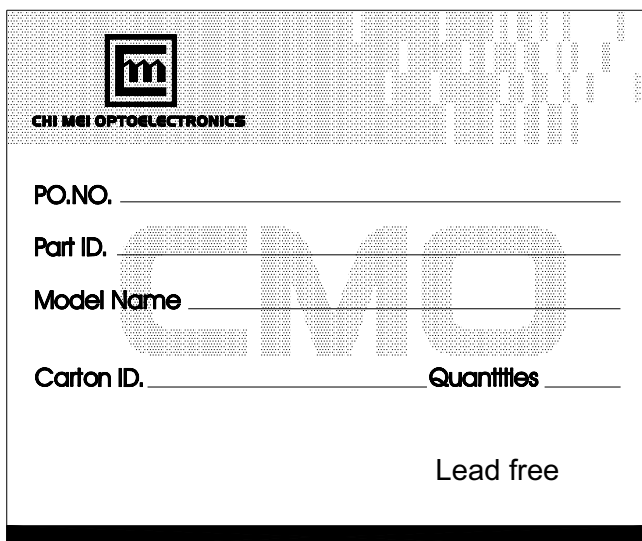

The image shows a template for a CMO (Carton Material Order) label. It features the CHI MEI OPTOELECTRONICS logo at the top left. Below the logo, there are four lines for inputting information: PO.NO., Part ID., Model Name, and Carton ID. The word 'CMO' is printed in large, semi-transparent letters across the middle of the form. To the right of the 'Carton ID.' line, there is a field for 'Quantities'. At the bottom center of the form, it says 'Lead free'. A large, diagonal watermark 'www.panelook.com' is overlaid on the entire page.

  
CHI MEI OPTOELECTRONICS

PO.NO. \_\_\_\_\_

Part ID. \_\_\_\_\_

Model Name \_\_\_\_\_

Carton ID. \_\_\_\_\_ Quantities \_\_\_\_\_

Lead free



## 10. PACKAGING

### 10.1 PACKING SPECIFICATIONS

- (1) 20 LCD modules / 1 Box
- (2) Box dimensions : 500(L) X 400(W) X 330(H) mm
- (3) Weight : approximately 11.2Kg (20 modules per box)

### 10.2 PACKING METHOD

(1) Carton Packing should have no failure in the following reliability test items.

Test Item	Test Conditions	Note
Vibration	Random, 2-200 Hz, follow ISTA standard	Non Operation
Dropping Test	1 Angle, 3 Edge, 6 Face, 60cm	Non Operation

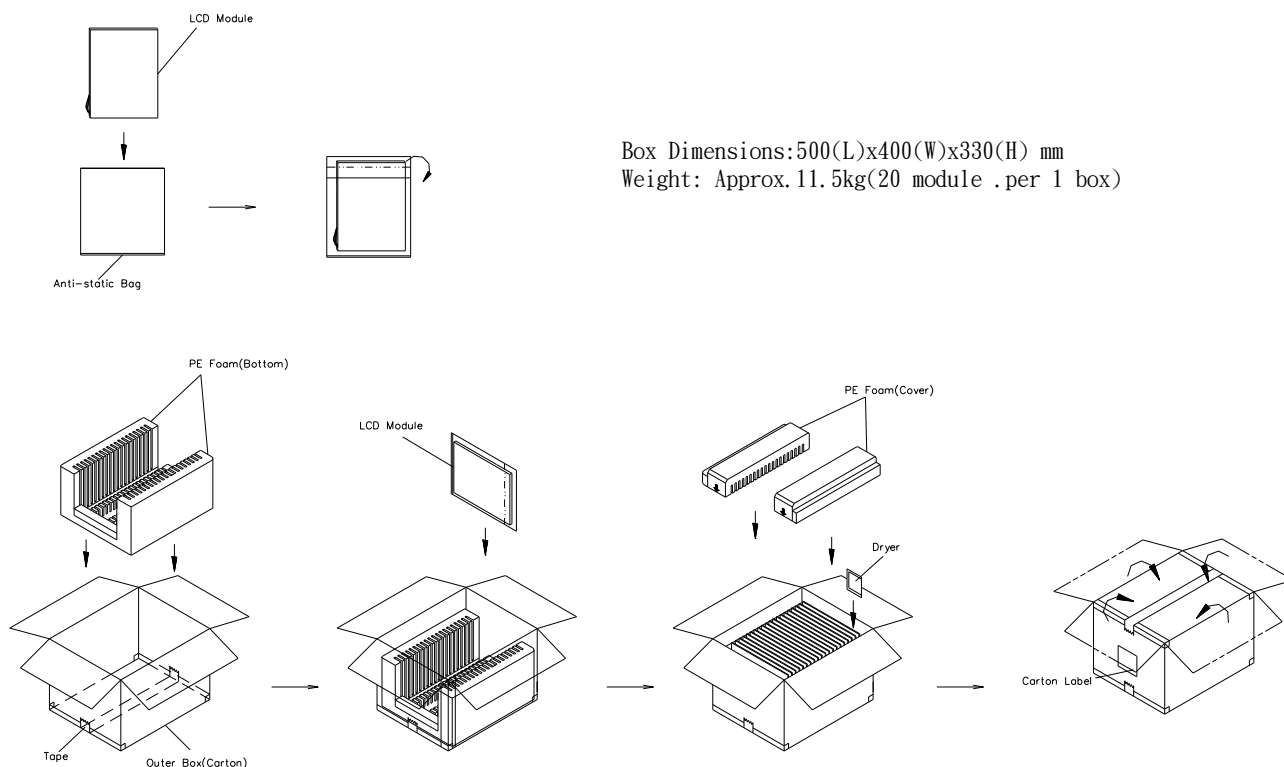

**Figure. 10-1 Packing method**

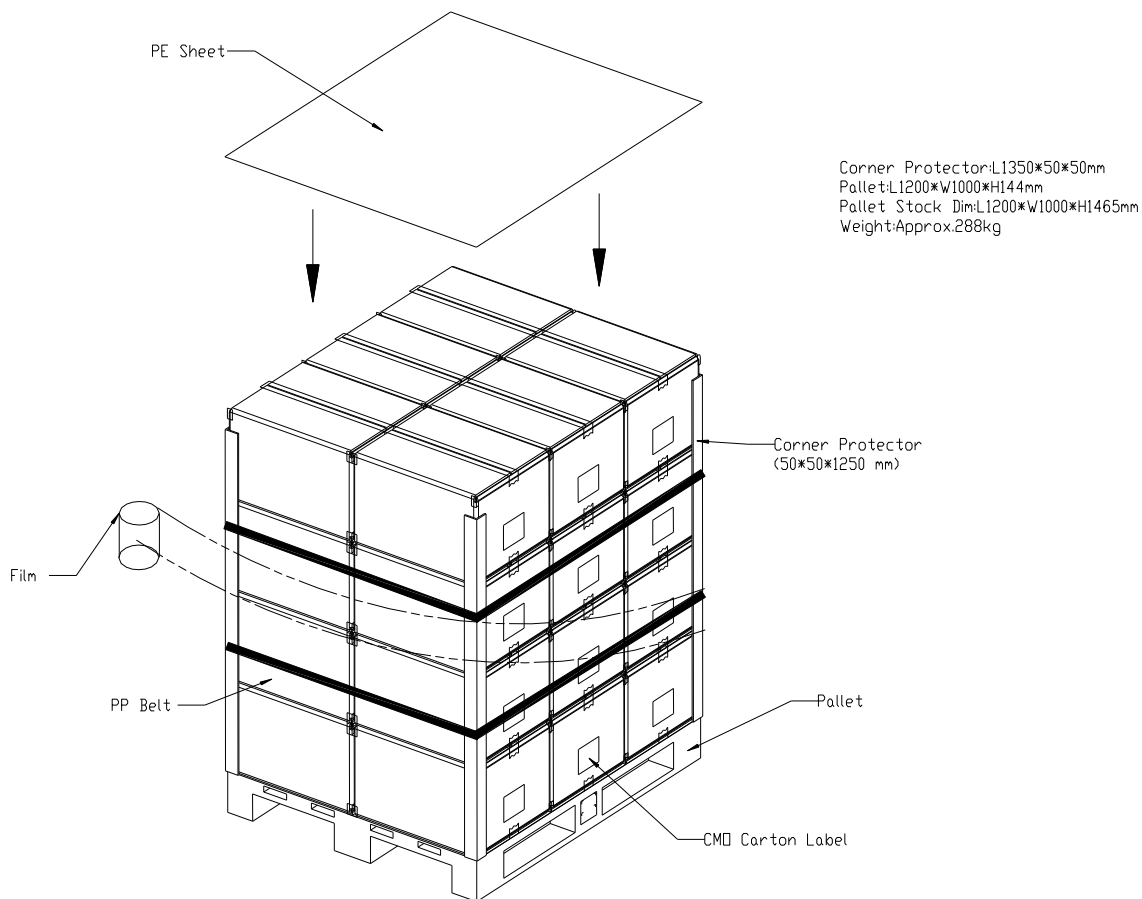

**Figure. 10-2 Packing method**

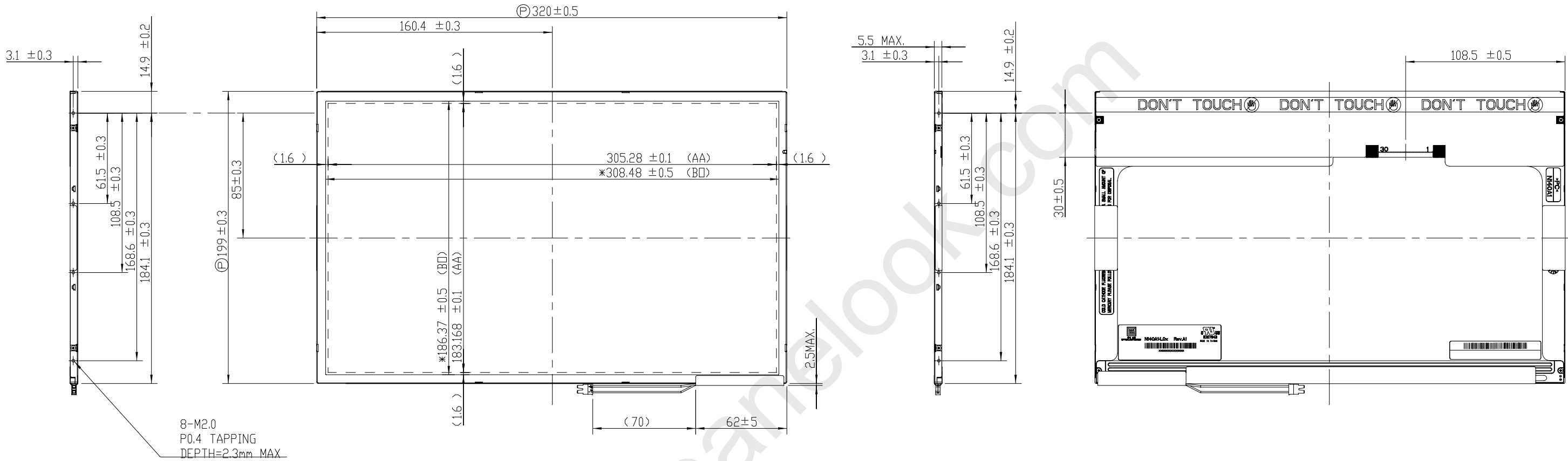

NOTES:  
 1.\* MARKS THE DESIGN CRITICAL DIMENSION.  
 2.Ⓢ MARKS THE PROCESS CRITICAL DIMENSION.  
 3.MAX.SCREW LENGTH:2.3 mm.  
 4.MAX.SCREW TORQUE:2.0 kgf-cm.  
 5.SIGNAL INTERFACE CONNECTOR: FI-XB30SL-HF10 (JAE)  
 6.CCFL CONNECTOR: BHSR-02VS-1 (JST)

TITLE	Module Outline N140A1			2D REV. A
				3D REV. 1.24
Approved	Bill Sheu	Drawing No.	N14014101A	
Checked	Yule Lin	Part No.	NA	
Drawer	Shunnan	Material	NA	Sheet 1 / 1 A2
Designer	Shunnan	Date	17-Feb-2005	Scale 1:2 Unit:mm
		CHI MEI OPTOELECTRONICS CORP. ALL RIGHTS RESERVED, COPYING FORBIDDEN.		

Mark	Description	Date	Changed_By	Approved_By	ECN No.	Remark
1						
2						
3						
4						
5						
6						
7						
8						