

# PRODUCT SPECIFICATION

**Doc. Number:**

- Tentative Specification
- Preliminary Specification
- Approval Specification

**MODEL NO.: N140BGE**  
**SUFFIX: P23**

<b>Customer:</b>	
<b>APPROVED BY</b>	<b>SIGNATURE</b>
<b>Name / Title</b>	_____
Note	_____
<p>_____</p> <p>Please return 1 copy for your confirmation with your signature and comments.</p>	

<b>Approved By</b> 楊竣傑 2013-06-08 15:50:37 CST	<b>Checked By</b> 曹文彬 2013-05-30 17:24:27 CST	<b>Prepared By</b> 王淑玲 2013-05-29 19:00:47 CST
---	--	---

**CONTENTS**

<b>1. GENERAL DESCRIPTION .....</b>	<b>4</b>
1.1 OVERVIEW .....	4
1.2 GENERAL SPECIFICATIONS .....	4
<b>2. MECHANICAL SPECIFICATIONS .....</b>	<b>4</b>
2.1 CONNECTOR TYPE .....	4
2.1.2 LED Light-Bar Connector .....	5
<b>3. ABSOLUTE MAXIMUM RATINGS .....</b>	<b>6</b>
3.1 ABSOLUTE RATINGS OF ENVIRONMENT .....	6
3.2 ABSOLUTE RATINGS OF ENVIRONMENT(OPEN CELL) .....	6
3.3 ELECTRICAL ABSOLUTE RATINGS(OPEN CELL) .....	7
3.3.1 TFT LCD MODULE .....	7
<b>4. ELECTRICAL SPECIFICATIONS.....</b>	<b>8</b>
4.1 FUNCTION BLOCK DIAGRAM.....	8
4.2. INTERFACE CONNECTIONS .....	8
4.3 ELECTRICAL CHARACTERISTICS.....	10
4.3.1 LCD ELETRONICS SPECIFICATION .....	10
4.3.2 LED CONVERTER SPECIFICATION.....	12
4.4 LVDS INPUT SIGNAL TIMING SPECIFICATIONS .....	14
4.4.1 LVDS DC SPECIFICATIONS .....	14
4.4.2 LVDS DATA FORMAT .....	14
4.4.3 COLOR DATA INPUT ASSIGNMENT .....	15
4.5 DISPLAY TIMING SPECIFICATIONS .....	16
4.6 POWER ON/OFF SEQUENCE .....	17
<b>5. OPTICAL CHARACTERISTICS .....</b>	<b>18</b>
5.1 TEST CONDITIONS.....	18
5.2 OPTICAL SPECIFICATIONS .....	18
<b>6. PACKING.....</b>	<b>22</b>
6.1 INNOLUX OPEN CELL LABEL .....	22
6.2 CARTON .....	23
6.3 PALLET.....	24
6.4 UNPACKING .....	25
<b>7. PRECAUTIONS .....</b>	<b>26</b>
7.1 HANDLING PRECAUTIONS.....	26
7.2 STORAGE PRECAUTIONS .....	26
7.3 OPERATION PRECAUTIONS.....	26
Appendix. OUTLINE DRAWING .....	27

## REVISION HISTORY

Version	Date	Page	Description
2.0	May. 22, 2013	All	Approval Spec Ver.2.0 was first issued.

## 1. GENERAL DESCRIPTION

### 1.1 OVERVIEW

N140BGE-P23 is a 14.0" (14.0" diagonal) TFT Liquid Crystal Display module with LED Backlight unit and 40 pins LVDS interface. This module supports 1366 x 768 HD mode and can display 262,144 colors. The optimum viewing angle is at 6 o'clock direction.

### 1.2 GENERAL SPECIFICATIONS

Item	Specification	Unit	Note
Screen Size	14.0" diagonal		
Driver Element	a-si TFT active matrix	-	-
Pixel Number	1366 x R.G.B. x 768	pixel	-
Pixel Pitch	0.2265 (H) x 0.2265 (V)	mm	-
Pixel Arrangement	RGB vertical stripe	-	-
Display Colors	262,144	color	-
Transmissive Mode	Normally white	-	-
Surface Treatment	Hard coating (3H), Glare	-	-

## 2. MECHANICAL SPECIFICATIONS

item		Min.	Typ.	Max.	Unit	Note
Size	Horizontal (H) with PCB	318.39	318.49	318.59	mm	(1) (2) g
	Horizontal (H) w/o PCB	318.39	318.49	318.59	mm	
	Vertical (V) with PCB	223.65	224.65	225.65	mm	
	Vertical (V) w/o PCB	182.75	182.85	182.95	mm	
	Thickness (T) with PCB	-	-	1.65	mm	
	Thickness (T) w/o PCB	1.21	1.27	1.33	mm	
Weight		-	170	180	-	
I/F connector mounting position		The mounting inclination of the connector makes the screen center within $\pm 0.5\text{mm}$ as the horizontal.				

Note (1) Please refer to the attached drawings for more information of front and back outline dimensions.

(2) Connector mounting position

### 2.1 CONNECTOR TYPE

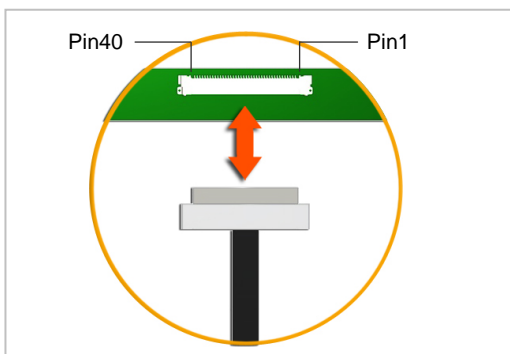

Please refer Appendix Outline Drawing for detail design.

Connector Part No.: IPEX-20455-040E-12 or TYCO 5-2069716-3.

User's connector Part No: IPEX-20453-040T-01.

## 2.1.2 LED Light-Bar Connector

北京鑫源意通	1-050010-0
信盛	STM: MSK24022P10A (10 Pin 下接觸)

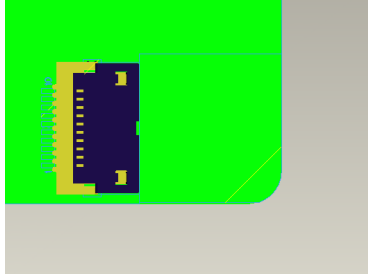

**3. ABSOLUTE MAXIMUM RATINGS**

**3.1 ABSOLUTE RATINGS OF ENVIRONMENT**

Item	Symbol	Value		Unit	Note
		Min.	Max.		
Storage Temperature	T <sub>ST</sub>	-20	+60	°C	(1)
Operating Ambient Temperature	T <sub>OP</sub>	0	+50	°C	(1), (2)

Note (1) (a) 90 %RH Max. (Ta <= 40 °C).

(b) Wet-bulb temperature should be 39 °C Max. (Ta > 40 °C).

(c) No condensation.

Note (2) The temperature of panel surface should be 0 °C min. and 60 °C max.

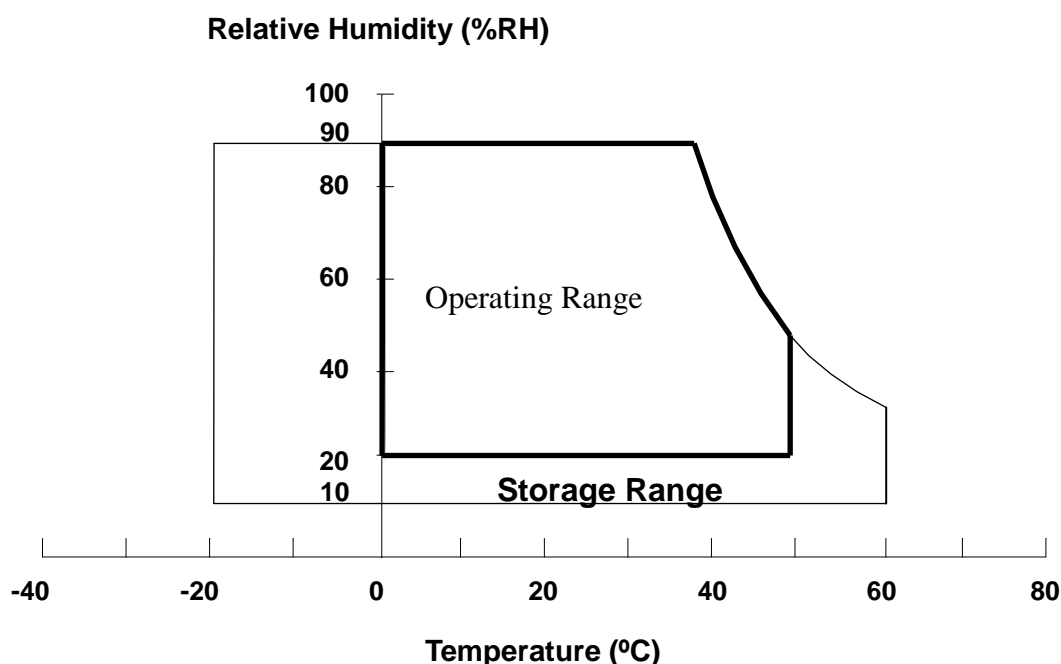

**3.2 ABSOLUTE RATINGS OF ENVIRONMENT(OPEN CELL)**

High temperature or humidity may reduce the performance of panel. Please store LCD panel within the specified storage conditions.

Storage Condition: With packing.

Storage temperature range: 25±5 °C.

Storage humidity range: 50±10%RH.

Shelf life: 30days

## 3.3 ELECTRICAL ABSOLUTE RATINGS(OPEN CELL)

### 3.3.1 TFT LCD MODULE

Item	Symbol	Value		Unit	Note
		Min.	Max.		
Power Supply Voltage	VCCS	-0.3	+4.0	V	(1)
Logic Input Voltage	V <sub>IN</sub>	-0.3	VCCS+0.3	V	
Converter Input Voltage	LED_VCCS	-0.3	26.0	V	(1)
Converter Control Signal Voltage	LED_PWM,	-0.3	5.0	V	(1)
Converter Control Signal Voltage	LED_EN	-0.3	5.0	V	(1)

Note (1) Stresses beyond those listed in above “ELECTRICAL ABSOLUTE RATINGS” may cause permanent damage to the device. Normal operation should be restricted to the conditions described in “ELECTRICAL CHARACTERISTICS”.

**4. ELECTRICAL SPECIFICATIONS**

**4.1 FUNCTION BLOCK DIAGRAM**

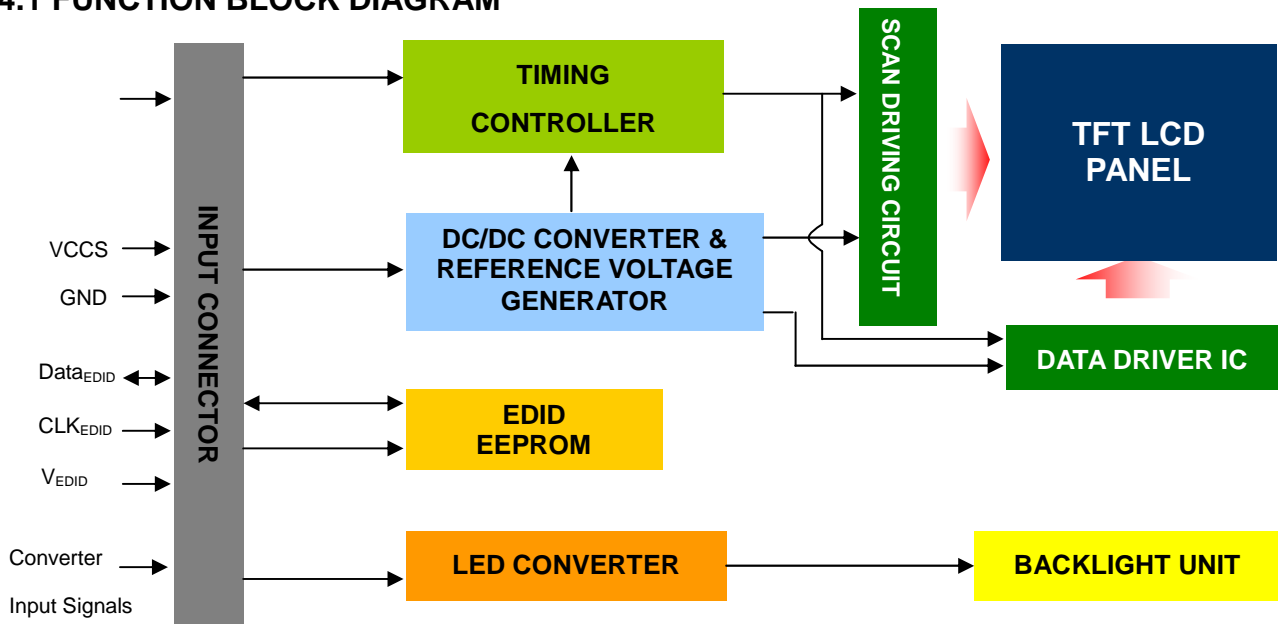

**4.2. INTERFACE CONNECTIONS**

PIN ASSIGNMENT

Pin	Symbol	Description	Remark
1	NC	No Connection (Reserve)	
2	VCCS	Power Supply (3.3V typ.)	
3	VCCS	Power Supply (3.3V typ.)	
4	VEDID	DDC 3.3V power	
5	NC	No Connection (Reserved for INNOLUX test)	
6	CLKEDID	DDC clock	
7	DATAEDID	DDC data	
8	Rxin0-	LVDS differential data input	R0-R5, G0
9	Rxin0+	LVDS differential data input	
10	VSS	Ground	
11	Rxin1-	LVDS differential data input	G1-G5, B0, B1
12	Rxin1+	LVDS differential data input	
13	VSS	Ground	
14	Rxin2-	LVDS Differential Data Input	B2-B5,HS,VS, DE
15	Rxin2+	LVDS Differential Data Input	
16	VSS	Ground	
17	RxCLK-	LVDS differential clock input	LVDS CLK
18	RxCLK+	LVDS differential clock input	
19	VSS	Ground	
20	NC	No Connection (Reserve)	
21	NC	No Connection (Reserve)	
22	VSS	Ground	
23	NC	No Connection (Reserve)	



24	NC	No Connection (Reserve)	
25	VSS	Ground	
26	NC	No Connection (Reserve)	
27	NC	No Connection (Reserve)	
28	VSS	Ground	
29	NC	No Connection (Reserve)	
30	NC	No Connection (Reserve)	
31	LED_GND	LED Ground	
32	LED_GND	LED Ground	
33	LED_GND	LED Ground	
34	NC	No Connection (Reserve)	
35	LED_PWM	PWM Control Signal of LED Converter	
36	LED_EN	Enable Control Signal of LED Converter	
37	NC	No Connection (Reserve)	
38	LED_VCCS	LED Power Supply	
39	LED_VCCS	LED Power Supply	
40	LED_VCCS	LED Power Supply	

Note (1) The first pixel is odd as shown in the following figure.

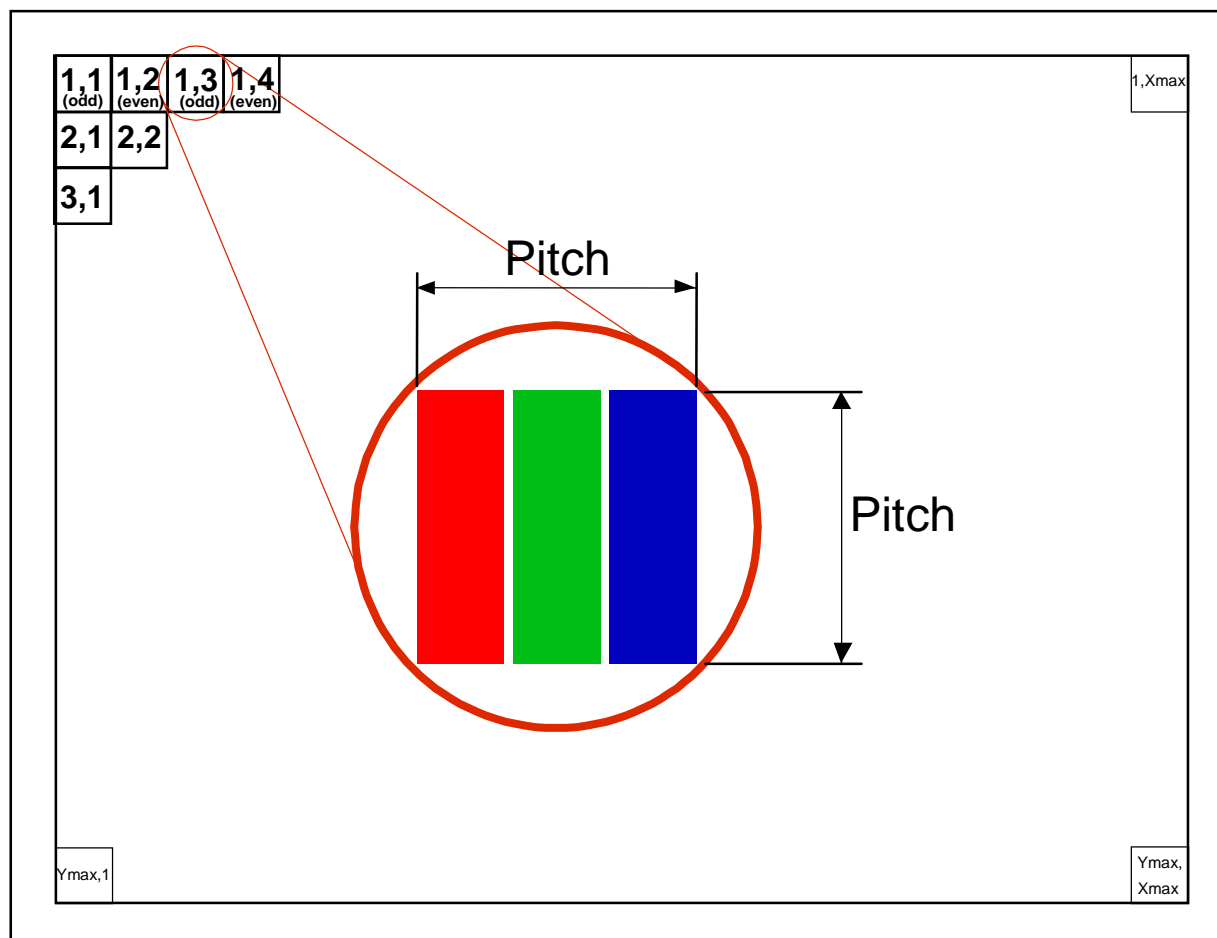

**4.3 ELECTRICAL CHARACTERISTICS**

**4.3.1 LCD ELETRONICS SPECIFICATION**

Parameter	Symbol	Value			Unit	Note
		Min.	Typ.	Max.		
Power Supply Voltage	VCCS	3.0	3.3	3.6	V	(1)
Ripple Voltage	V <sub>RP</sub>	-	50	-	mV	(1)
Inrush Current	I <sub>RUSH</sub>	-	-	1.5	A	(1),(2)
Power Supply Current	Mosaic	-	206	224	mA	(3)a
	Black	-	201	219	mA	(3)

Note (1) The ambient temperature is Ta = 25 ± 2 °C.

Note (2) I<sub>RUSH</sub>: the maximum current when VCCS is rising

I<sub>IS</sub>: the maximum current of the first 100ms after power-on

Measurement Conditions: Shown as the following figure. Test pattern: black.

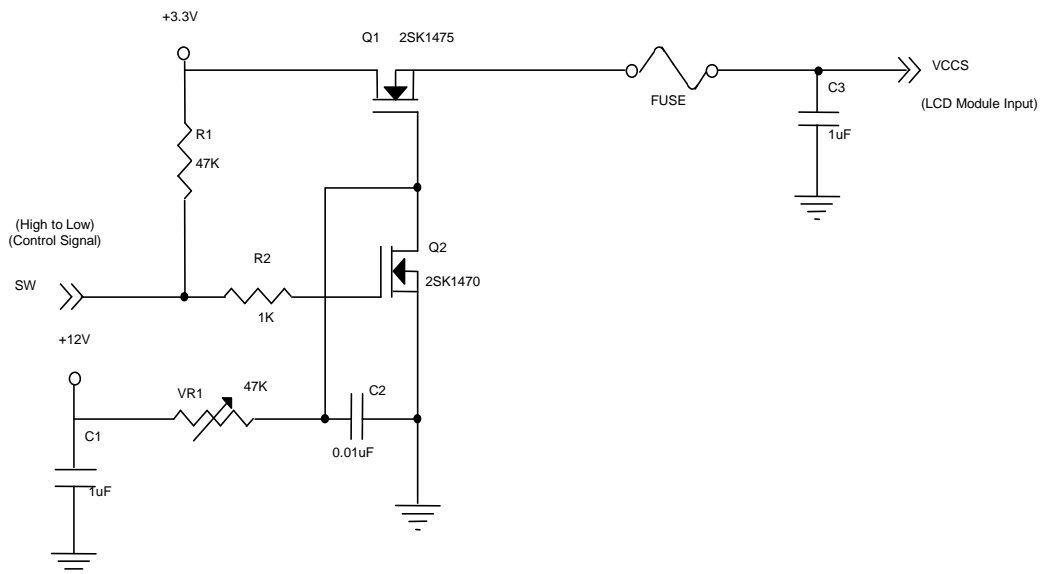

**VCCS rising time is 0.5ms**

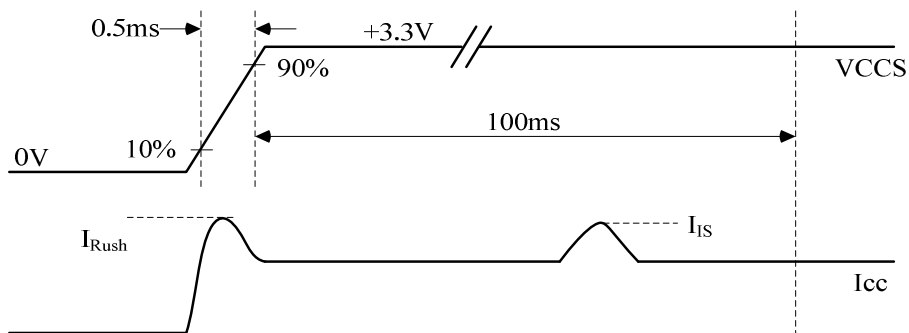

Note (3) The specified power supply current is under the conditions at  $V_{CCS} = 3.3\text{ V}$ ,  $T_a = 25 \pm 2\text{ }^\circ\text{C}$ , DC Current and  $f_v = 60\text{ Hz}$ , whereas a specified power dissipation check pattern is displayed

a. Mosaic Pattern

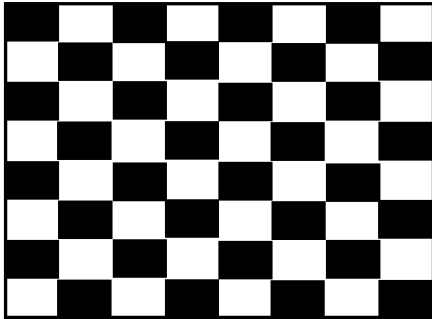

Active Area

**4.3.2 LED CONVERTER SPECIFICATION**

Parameter		Symbol	Value			Unit	Note
			Min.	Typ.	Max.		
Converter Input power supply voltage		LED_Vccs	5.0	12.0	21.0	V	
Converter Inrush Current		I <sub>LED_RUSH</sub>	-	-	1.5	A	(1)
EN Control Level	Backlight On		2.2	-	3.6	V	
	Backlight Off		0	-	0.6	V	
PWM Control Level	PWM High Level		2.2	-	3.6	V	
	PWM Low Level		0	-	0.6	V	
PWM Control Duty Ratio			5	-	100	%	
PWM Control Permissible Ripple Voltage		V <sub>PWM_pp</sub>	-	-	100	mV	
PWM Control Frequency		f <sub>PWM</sub>	190	-	2K	Hz	(2)
LED Power Current	LED_VCCS =Typ.	I <sub>LED</sub>	-	175	202	mA	(3)

Note (1) I<sub>LED\_RUSH</sub>: the maximum current when LED\_VCCS is rising,

I<sub>LED\_S</sub>: the maximum current of the first 100ms after power-on,

Measurement Conditions: Shown as the following figure. LED\_VCCS = Typ, Ta = 25 ± 2 °C, f<sub>PWM</sub> = 200 Hz, Duty=100%.

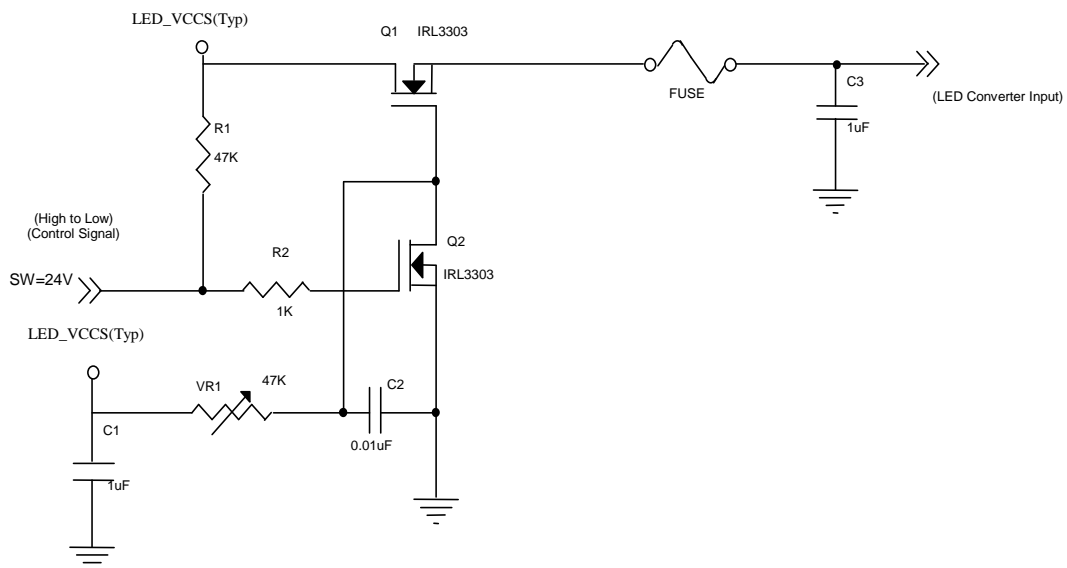

# PRODUCT SPECIFICATION

**VLED rising time is 0.5ms**

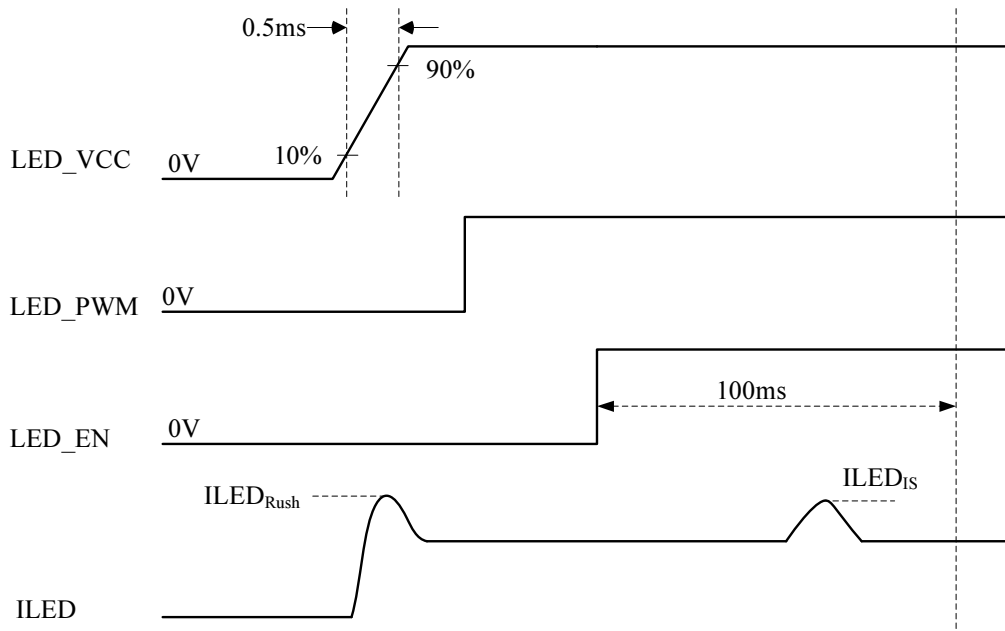

Note (2) If PWM control frequency is applied in the range less than 1KHz, the “waterfall” phenomenon on the screen may be found. To avoid the issue, it’s a suggestion that PWM control frequency should follow the criterion as below.

PWM control frequency  $f_{PWM}$  should be in the range

$$(N + 0.33) * f \leq f_{PWM} \leq (N + 0.66) * f$$

$N$  : Integer ( $N \geq 3$ )

$f$  : Frame rate

Note (3) The specified LED power supply current is under the conditions at “LED\_VCCS = Typ.”,  $T_a = 25 \pm 2 \text{ }^\circ\text{C}$ ,  $f_{PWM} = 200 \text{ Hz}$ , Duty=100%.

**4.4 LVDS INPUT SIGNAL TIMING SPECIFICATIONS**

**4.4.1 LVDS DC SPECIFICATIONS**

Parameter	Symbol	Value			Unit	Note
		Min.	Typ.	Max.		
LVDS Differential Input High Threshold	$V_{TH(LVDS)}$	-	-	+100	mV	(1), $V_{CM}=1.2V$
LVDS Differential Input Low Threshold	$V_{TL(LVDS)}$	-100	-	-	mV	(1) $V_{CM}=1.2V$
LVDS Common Mode Voltage	$V_{CM}$	1.125	-	1.375	V	(1)
LVDS Differential Input Voltage	$ V_{ID} $	100	-	600	mV	(1)
LVDS Terminating Resistor	$R_T$		100		Ohm	-

Note (1) The parameters of LVDS signals are defined as the following figures.

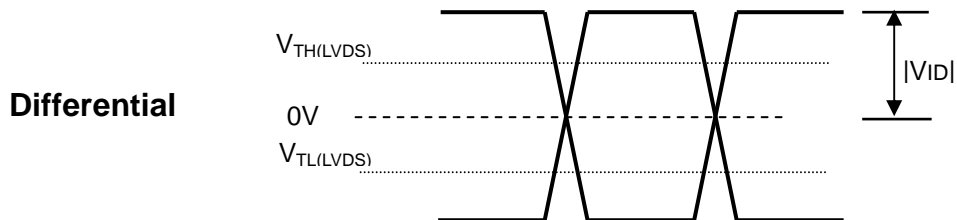
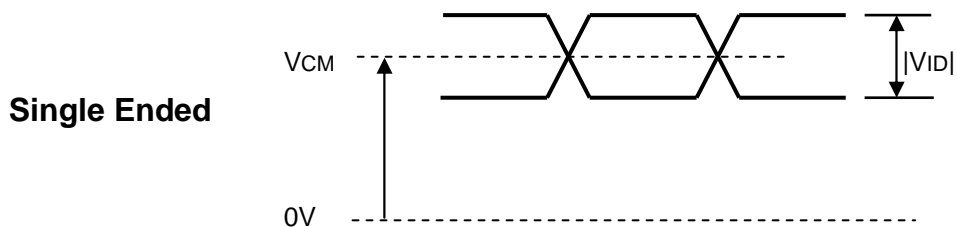

**4.4.2 LVDS DATA FORMAT**

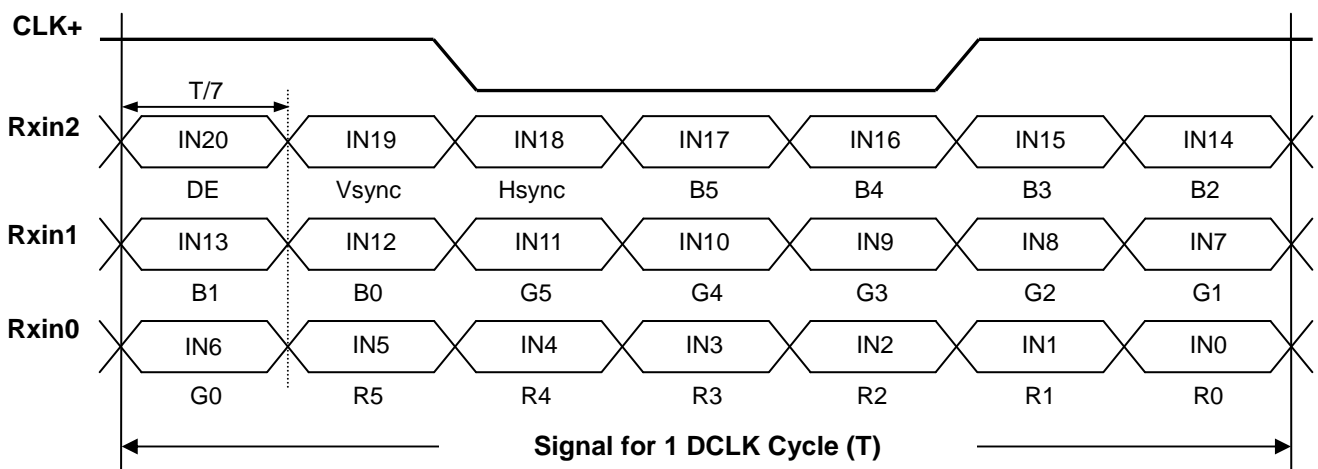

## 4.4.3 COLOR DATA INPUT ASSIGNMENT

The brightness of each primary color (red, green and blue) is based on the 6-bit gray scale data input for the color. The higher the binary input the brighter the color. The table below provides the assignment of color versus data input.

Color		Data Signal																	
		Red						Green						Blue					
		R5	R4	R3	R2	R1	R0	G5	G4	G3	G2	G1	G0	B5	B4	B3	B2	B1	B0
Basic Colors	Black	0	0	0	0	0	0	0	0	0	0	0	0	0	0	0	0	0	0
	Red	1	1	1	1	1	1	0	0	0	0	0	0	0	0	0	0	0	0
	Green	0	0	0	0	0	0	1	1	1	1	1	1	0	0	0	0	0	0
	Blue	0	0	0	0	0	0	0	0	0	0	0	0	1	1	1	1	1	1
	Cyan	0	0	0	0	0	0	1	1	1	1	1	1	1	1	1	1	1	1
	Magenta	1	1	1	1	1	1	0	0	0	0	0	0	1	1	1	1	1	1
	Yellow	1	1	1	1	1	1	1	1	1	1	1	1	0	0	0	0	0	0
	White	1	1	1	1	1	1	1	1	1	1	1	1	1	1	1	1	1	1
Gray Scale Of Red	Red(0)/Dark	0	0	0	0	0	0	0	0	0	0	0	0	0	0	0	0	0	
	Red(1)	0	0	0	0	0	1	0	0	0	0	0	0	0	0	0	0	0	
	Red(2)	0	0	0	0	1	0	0	0	0	0	0	0	0	0	0	0	0	
	:	:	:	:	:	:	:	:	:	:	:	:	:	:	:	:	:	:	
	:	:	:	:	:	:	:	:	:	:	:	:	:	:	:	:	:	:	
	Red(61)	1	1	1	1	0	1	0	0	0	0	0	0	0	0	0	0	0	
	Red(62)	1	1	1	1	1	0	0	0	0	0	0	0	0	0	0	0	0	
	Red(63)	1	1	1	1	1	1	0	0	0	0	0	0	0	0	0	0	0	
Gray Scale Of Green	Green(0)/Dark	0	0	0	0	0	0	0	0	0	0	0	0	0	0	0	0	0	
	Green(1)	0	0	0	0	0	0	0	0	0	0	0	1	0	0	0	0	0	
	Green(2)	0	0	0	0	0	0	0	0	0	0	1	0	0	0	0	0	0	
	:	:	:	:	:	:	:	:	:	:	:	:	:	:	:	:	:	:	
	:	:	:	:	:	:	:	:	:	:	:	:	:	:	:	:	:	:	
	Green(61)	0	0	0	0	0	0	1	1	1	1	0	1	0	0	0	0	0	
	Green(62)	0	0	0	0	0	0	1	1	1	1	1	0	0	0	0	0	0	
	Green(63)	0	0	0	0	0	0	1	1	1	1	1	1	0	0	0	0	0	
Gray Scale Of Blue	Blue(0)/Dark	0	0	0	0	0	0	0	0	0	0	0	0	0	0	0	0	0	
	Blue(1)	0	0	0	0	0	0	0	0	0	0	0	0	0	0	0	0	1	
	Blue(2)	0	0	0	0	0	0	0	0	0	0	0	0	0	0	0	1	0	
	:	:	:	:	:	:	:	:	:	:	:	:	:	:	:	:	:	:	
	:	:	:	:	:	:	:	:	:	:	:	:	:	:	:	:	:	:	
	Blue(61)	0	0	0	0	0	0	0	0	0	0	0	0	1	1	1	1	0	
	Blue(62)	0	0	0	0	0	0	0	0	0	0	0	0	1	1	1	1	0	
	Blue(63)	0	0	0	0	0	0	0	0	0	0	0	0	1	1	1	1	1	

Note (1) 0: Low Level Voltage, 1: High Level Voltage

**4.5 DISPLAY TIMING SPECIFICATIONS**

The input signal timing specifications are shown as the following table and timing diagram.

Signal	Item	Symbol	Min.	Typ.	Max.	Unit	Note
DCLK	Frequency	1/Tc	72.6	76.42	80.24	MHz	-
DE	Vertical Total Time	TV	775	800	808	TH	-
	Vertical Active Display Period	TVD	768	768	768	TH	-
	Vertical Active Blanking Period	TVB	TV-TVD	32	TV-TVD	TH	-
	Horizontal Total Time	TH	1466	1592	1648	Tc	-
	Horizontal Active Display Period	THD	1366	1366	1366	Tc	-
	Horizontal Active Blanking Period	THB	TH-THD	226	TH-THD	Tc	-

Note (1) Because this module is operated by DE only mode, Hsync and Vsync are ignored.

**INPUT SIGNAL TIMING DIAGRAM**

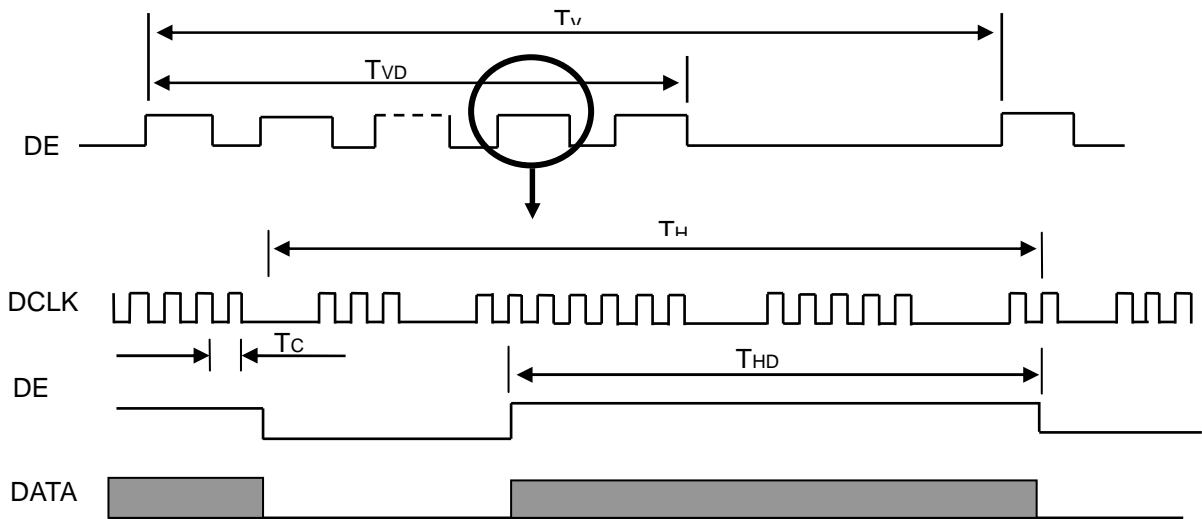



**4.6 POWER ON/OFF SEQUENCE**

The power sequence specifications are shown as the following table and diagram.

Symbol	Value			Unit	Note
	Min.	Typ.	Max.		
t1	0.5	-	10	ms	
t2	0	-	50	ms	
t3	0	-	50	ms	
t4	500	-	-	ms	
t5	200	-	-	ms	
t6	200	-	-	ms	
t7	0.5	-	10	ms	
t <sub>A</sub>	0.5	-	10	ms	
t <sub>B</sub>	0	-	10	ms	
t <sub>C</sub>	1	-	-	ms	
t <sub>D</sub>	1	-	-	ms	
t <sub>E</sub>	1	-	-	ms	
t <sub>F</sub>	1	-	-	ms	

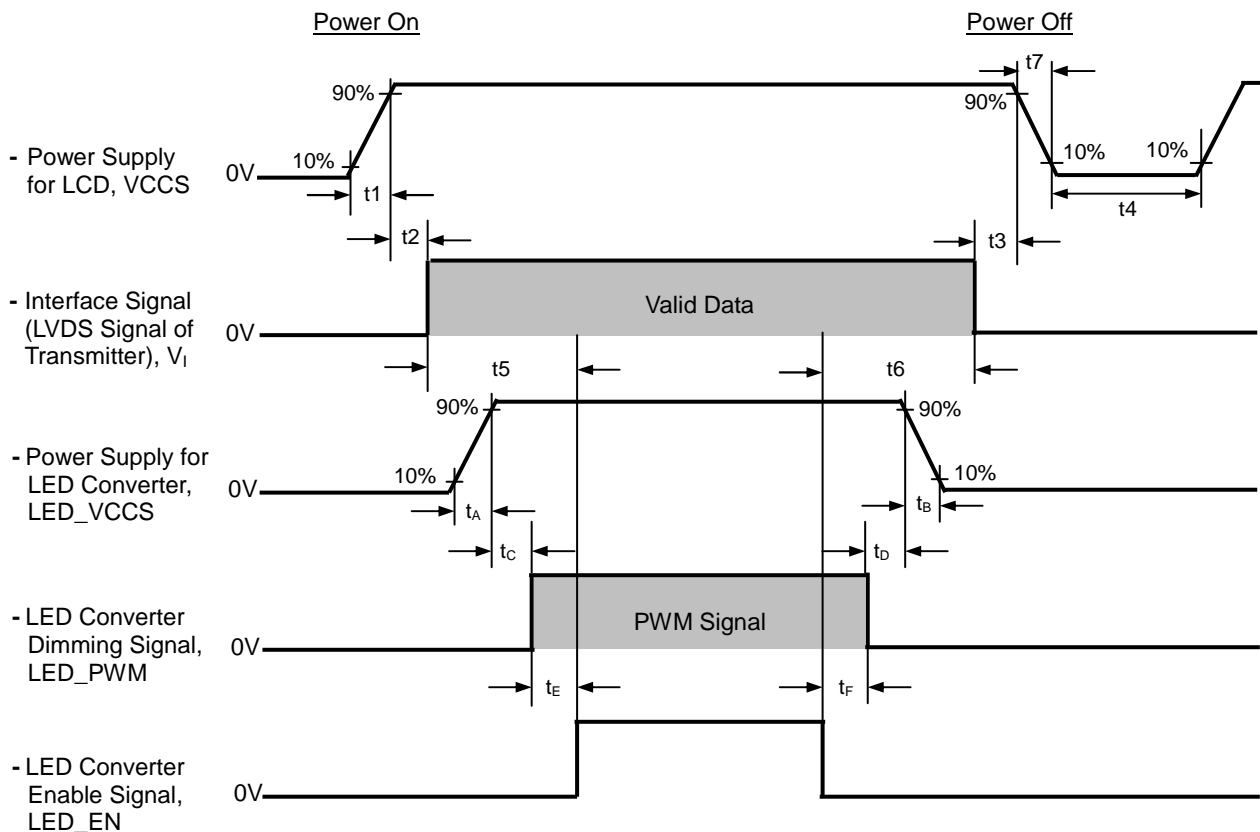

Note (1) Please don't plug or unplug the interface cable when system is turned on.

Note (2) Please avoid floating state of the interface signal during signal invalid period.

Note (3) It is recommended that the backlight power must be turned on after the power supply for LCD and the interface signal is valid.

## 5. OPTICAL CHARACTERISTICS

### 5.1 TEST CONDITIONS

Item	Symbol	Value	Unit
Ambient Temperature	Ta	25±2	°C
Ambient Humidity	Ha	50±10	%RH
Supply Voltage	V <sub>CC</sub>	3.3	V
Input Signal	According to typical value in "3. ELECTRICAL CHARACTERISTICS"		

The measurement methods of optical characteristics are shown in Section 5.2. The following items should be measured under the test conditions described in Section 5.1 and stable environment shown in Note (5).

### 5.2 OPTICAL SPECIFICATIONS

Item		Symbol	Condition	Min.	Typ.	Max.	Unit	Note	
Center Transmittance		T%	$\theta_x=0^\circ, \theta_y=0^\circ$	6.0	7.1			(1), (5), (8)	
Contrast Ratio		CR	CS-1000T, INNOLUX BLU	350	500			(1), (3), (5)	
Transmittance uniformity		$\delta$ T%	$\theta_x=0^\circ, \theta_y=0^\circ$ BM-5A			1.25		(1), (5), (7)	
Response Time		T <sub>R</sub>	$\theta_x=0^\circ, \theta_y=0^\circ$	-	3	8	ms	(4)	
		T <sub>F</sub>		-	7	13	ms		
Color Chromaticity	Red	Rcx	$\theta_x=0^\circ, \theta_y=0^\circ$ CS-1000T Standard light source "C"	Typ.- 0.03	0.599	Typ.+ 0.03	-	(0), (5)	
		Rcy			0.332		-		
	Green	Gcx			0.289		-		
		Gcy			0.542		-		
	Blue	Bcx			0.145		-		
		Bcy			0.202		-		
	White	Wcx			0.304		-		
		Wcy			0.357		-		
Viewing Angle	Horizontal	$\theta_{x+}$	CR≥10 BM-5A	40	45	-	Deg.	(1),(3),(5)	
		$\theta_{x-}$			45				
	Vertical	$\theta_{y+}$			15				20
		$\theta_{y-}$			40				45

Note (0) Light source is the standard light source "C" which is defined by CIE and driving voltages are based on suitable gamma voltages. The calculating method is as following :

1. Measure Module's and BLU's spectrums. White is without signal input and R, G, B are with signal input. BLU is supplied by INNOLUX.
2. Calculate cell's spectrum.
3. Calculate cell's chromaticity by using the spectrum of standard light source "C"

# PRODUCT SPECIFICATION

Note (1) Light source is the BLU which is supplied by INNOLUX and driving voltages are based on suitable gamma voltages. White is without signal input and R, G, B are with signal input. SPEC is judged by INNOLUX's golden sample.

Note (2) Definition of Viewing Angle ( $\theta_x, \theta_y$ ):

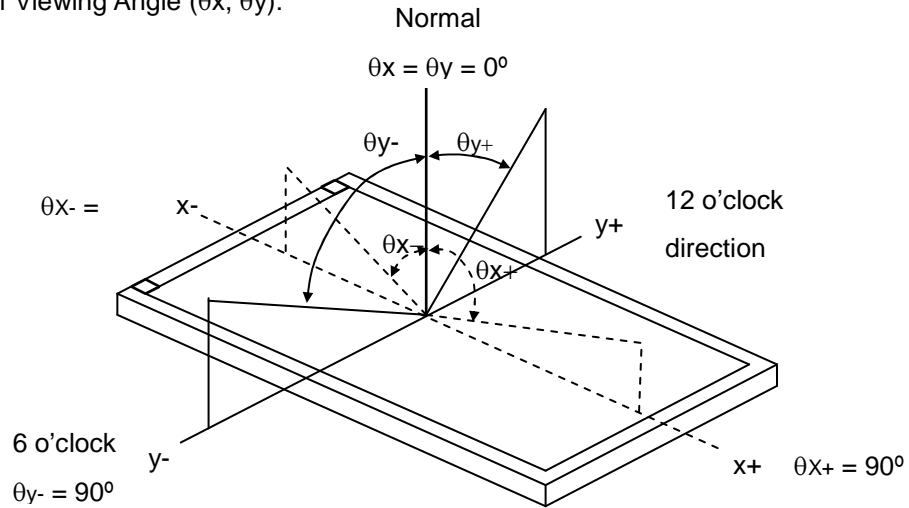

Note (3) Definition of Contrast Ratio (CR):

The contrast ratio can be calculated by the following expression.

$$\text{Contrast Ratio (CR)} = L_{63} / L_0$$

L63: Luminance of gray level 63

L 0: Luminance of gray level 0

$$\text{CR} = \text{CR} (1)$$

CR (X) is corresponding to the Contrast Ratio of the point X at Figure in Note (6).

Note (4) Definition of Response Time ( $T_R, T_F$ ):

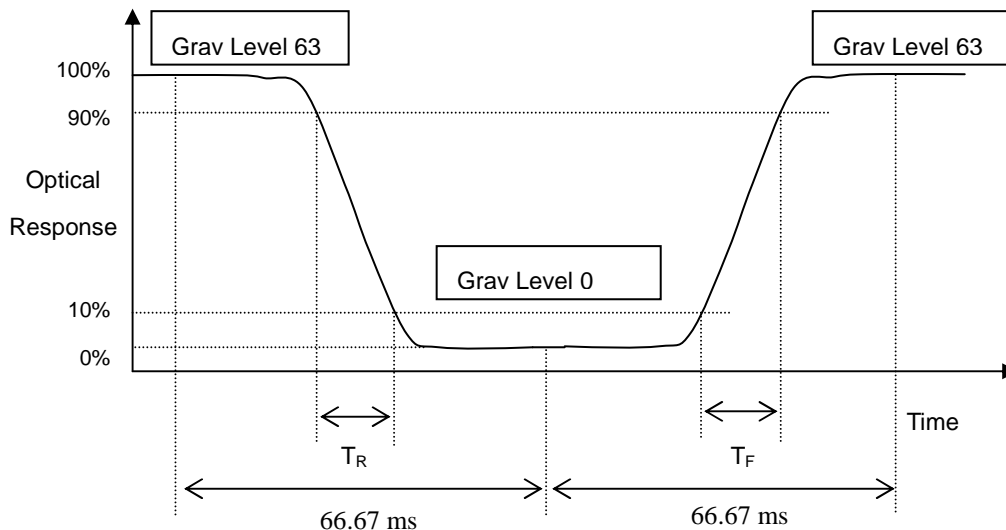

Note (5) Measurement Setup:

The LCD module should be stabilized at given temperature for 20 minutes to avoid abrupt temperature change during measuring. In order to stabilize the luminance, the measurement should be executed after lighting Backlight for 20 minutes in a windless room.

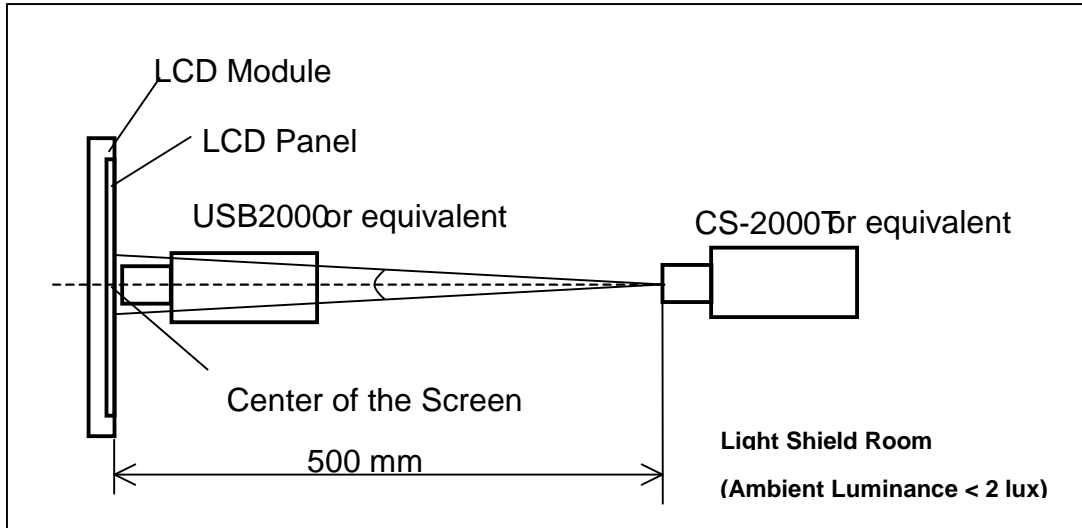

Note (6) Definition of Transmittance Variation ( $\delta T\%$ ):

Measure the transmittance at 5 points

$$\delta T\% = \frac{\text{Maximum } [T\%(1), T\%(2), \dots T\%(5)]}{\text{Minimum } [T\%(1), T\%(2), \dots T\%(5)]}$$

Note (7) Definition of Transmittance (T%):

Module is without signal input.

BLU is supplied by INNOLUX.

$$\text{Transmittance} = \frac{\text{Luminance of LCD module}}{\text{Luminance of backlight}} * 100\%$$

# PRODUCT SPECIFICATION

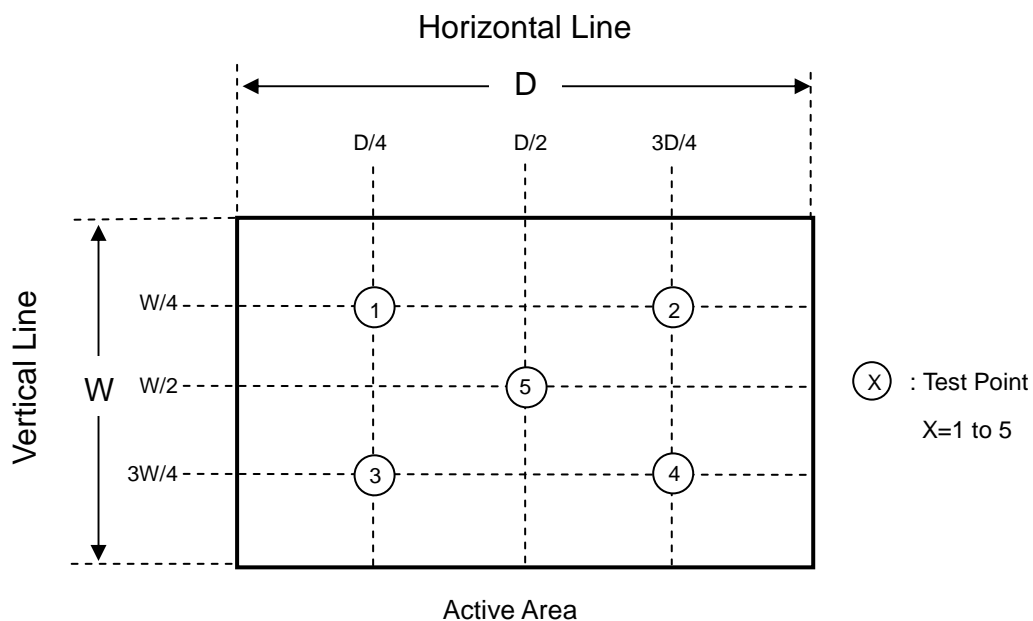

Note (8) The listed optical specifications refer to the initial value of manufacture, but the condition of the specifications after long-term operation will not be warranted.

**6. PACKING**

**6.1 INNOLUX OPEN CELL LABEL**

The barcode nameplate is pasted on each OPEN CELL as illustration for INNOLUX internal control.



- (a) Model Name: N140BGE - P23
- (b) Revision: Rev. XX, for example: C1, C2 ...etc.
- (c) Serial ID: X X X X X X Y M D L N N N N

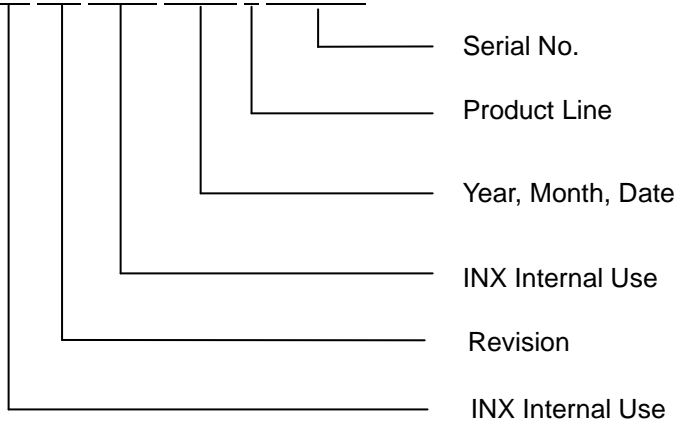

- (d) Production Location: MADE IN XXXX.
- (e) UL/CB logo: XXXX is UL factory ID.

Serial ID includes the information as below:

- (a) Manufactured Date: Year: 0~9, for 2010~2019  
 Month: 1~9, A~C, for Jan. ~ Dec.  
 Day: 1~9, A~Y, for 1<sup>st</sup> to 31<sup>st</sup>, exclude I , O and U
- (b) Revision Code: cover all the change
- (c) Serial No.: Manufacturing sequence of product
- (d) Product Line: 1 -> Line1, 2 -> Line 2, ...etc.

**6.2 CARTON**

(1) Carton Dimensions: 475(L)x390(W)x320(H)mm

(2) 27 LCD Cells+PCB/Carton

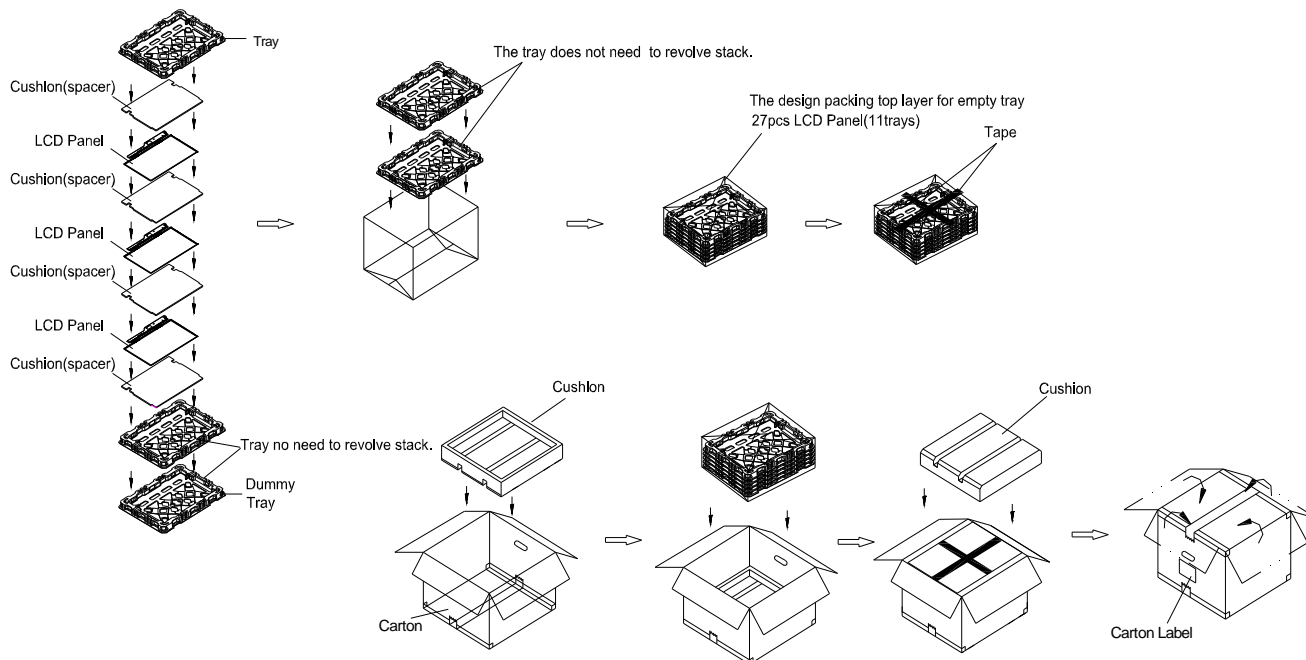

Figure. 6-2 Packing method

**6.3 PALLET**

Sea and Land Transportation

Air Transportation

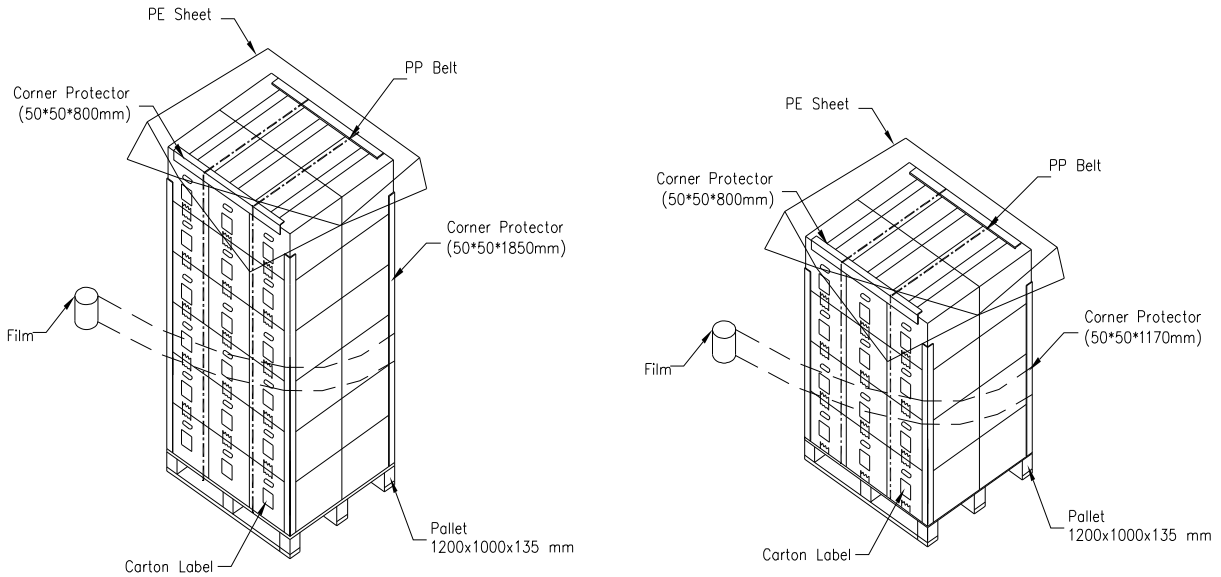

Figure. 6-3 Packing method



## 6.4 UNPACKING

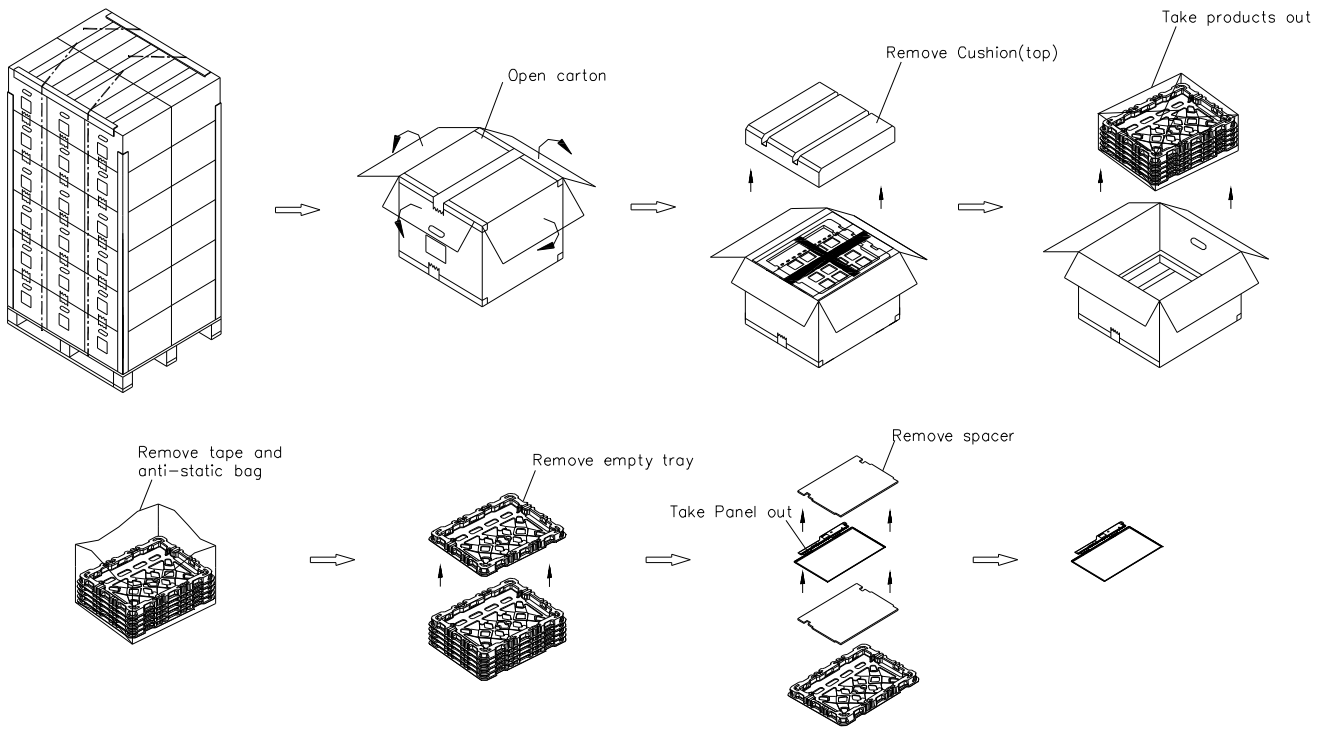

Figure. 6-4 Unpacking method

**7. PRECAUTIONS****7.1 HANDLING PRECAUTIONS**

- (1) The module should be assembled into the system firmly by using every mounting hole. Be careful not to twist or bend the module.
- (2) While assembling or installing modules, it can only be in the clean area. The dust and oil may cause electrical short or damage the polarizer.
- (3) Use fingerstalls or soft gloves in order to keep display clean during the incoming inspection and assembly process.
- (4) Do not press or scratch the surface harder than a HB pencil lead on the panel because the polarizer is very soft and easily scratched.
- (5) If the surface of the polarizer is dirty, please clean it by some absorbent cotton or soft cloth. Do not use Ketone type materials (ex. Acetone), Ethyl alcohol, Toluene, Ethyl acid or Methyl chloride. It might permanently damage the polarizer due to chemical reaction.
- (6) Wipe off water droplets or oil immediately. Staining and discoloration may occur if they left on panel for a long time.
- (7) If the liquid crystal material leaks from the panel, it should be kept away from the eyes or mouth. In case of contacting with hands, legs or clothes, it must be washed away thoroughly with soap.
- (8) Protect the module from static electricity, it may cause damage to the C-MOS Gate Array IC.
- (9) Do not disassemble the module.
- (10) Do not pull or fold the LED wire.
- (11) Pins of I/F connector should not be touched directly with bare hands.

**7.2 STORAGE PRECAUTIONS**

- (1) High temperature or humidity may reduce the performance of module. Please store LCD module within the specified storage conditions.
- (2) It is dangerous that moisture come into or contacted the LCD module, because the moisture may damage LCD module when it is operating.
- (3) It may reduce the display quality if the ambient temperature is lower than 10 °C. For example, the response time will become slowly, and the starting voltage of LED will be higher than the room temperature.

**7.3 OPERATION PRECAUTIONS**

- (1) Do not pull the I/F connector in or out while the module is operating.
- (2) Always follow the correct power on/off sequence when LCD module is connecting and operating. This can prevent the INXS LSI chips from damage during latch-up.
- (3) The startup voltage of Backlight is approximately 1000 Volts. It may cause electrical shock while assembling with converter. Do not disassemble the module or insert anything into the Backlight unit.

**Appendix. OUTLINE DRAWING**

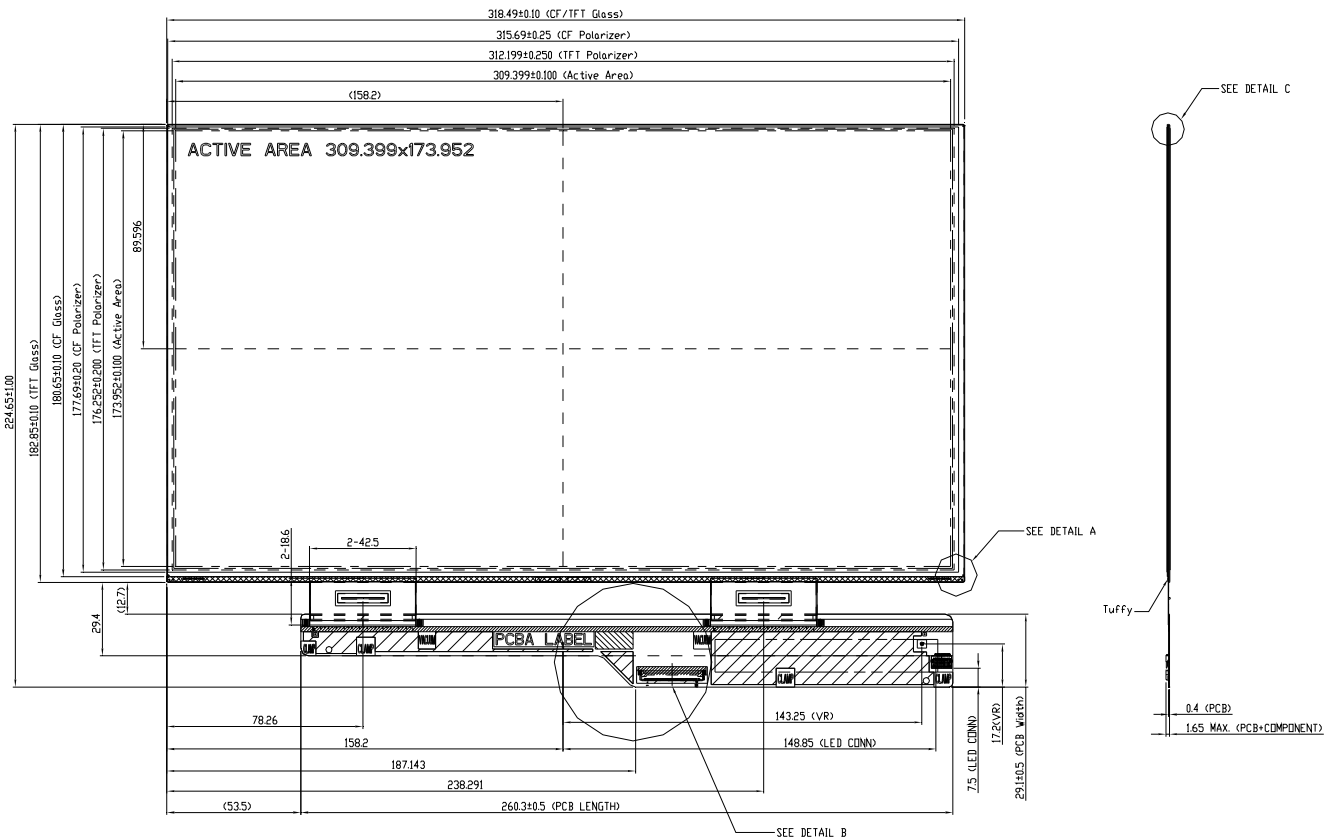

Note:

- 1.General Tolerance: ±0.2mm
- 2.LVDS Connector : I-PEX 20455-040E-12 or TYCD 5-2069716-3.
- 3.LED Connector : STM MSK24022P10A or Xin Da Yi Tong 1-050010-0

# PRODUCT SPECIFICATION

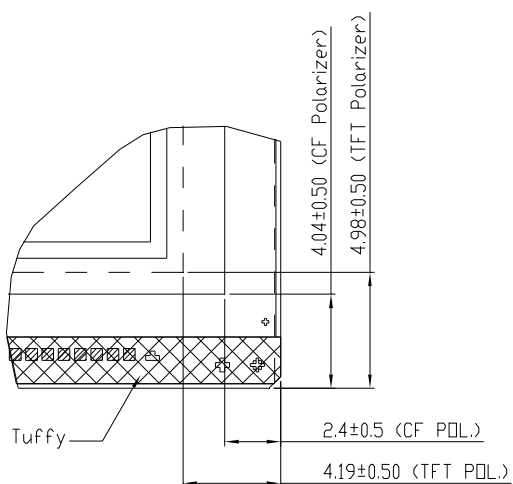

DETAIL A  
SCALE 5:1

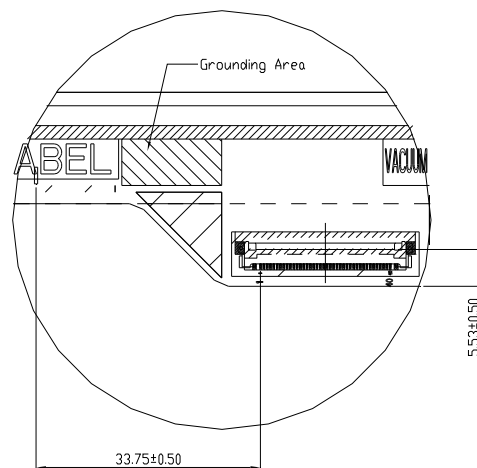

DETAIL B  
SCALE 2:1

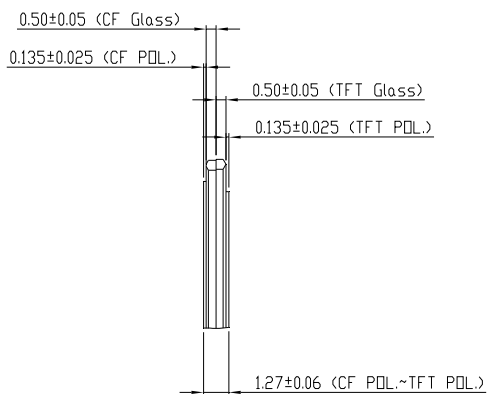

DETAIL C  
SCALE 5:1