

TFT LCD Approval Specification

MODEL NO.: N141I3 - L05

Customer:

Approved by:

Note:

- CONTENTS -

REVISION HISTORY	-----	3
1. GENERAL DESCRIPTION	-----	5
1.1 OVERVIEW		
1.2 FEATURES		
1.3 APPLICATION		
1.4 GENERAL SPECIFICATIONS		
1.5 MECHANICAL SPECIFICATIONS		
2. ABSOLUTE MAXIMUM RATINGS	-----	6
2.1 ABSOLUTE RATINGS OF ENVIRONMENT		
2.2 ELECTRICAL ABSOLUTE RATINGS		
2.2.1 TFT LCD MODULE		
2.2.2 BACKLIGHT UNIT		
3. ELECTRICAL CHARACTERISTICS	-----	8
3.1 TFT LCD MODULE		
3.2 BACKLIGHT UNIT		
4. BLOCK DIAGRAM	-----	12
4.1 TFT LCD MODULE		
4.2 BACKLIGHT UNIT		
5. INPUT TERMINAL PIN ASSIGNMENT	-----	13
5.1 TFT LCD MODULE		
5.2 BACKLIGHT UNIT		
5.3 TIMING DIAGRAM OF LVDS INPUT SIGNAL		
5.4 COLOR DATA INPUT ASSIGNMENT		
5.5 EDID DATA STRUCTURE		
6. INVERTER SPECIFICATION	-----	19
6.1 CONNECTOR TYPE		
6.2 INPUT CONNECTOR PIN ASSIGNMENT		
6.3 OUTPUT CONNECTOR PIN ASSIGNMENT		
6.4 GENERAL ELECTRICAL SPECIFICATION		
7. INTERFACE TIMING	-----	23
7.1 INPUT SIGNAL TIMING SPECIFICATIONS		
7.2 POWER ON/OFF SEQUENCE		
8. OPTICAL CHARACTERISTICS	-----	25
8.1 TEST CONDITIONS		
8.2 OPTICAL SPECIFICATIONS		
9. PRECAUTIONS	-----	29
9.1 HANDLING PRECAUTIONS		
9.2 STORAGE PRECAUTIONS		
9.3 OPERATION PRECAUTIONS		
10. PACKING	-----	30
10.1 CARTON		
10.2 PALLET (For Sea)		
10.3 PALLET (For Air)		

11. DEFINITION OF LABELS
11.1 CMO MODULE LABEL
11.2 CMO CARTON LABE

----- 33

REVISION HISTORY

Version	Date	Page (New)	Section	Description
0.0	Oct, 11, '06	All	All	Tentative specification was first issued.
1.0	Feb, 7, 07	All	All	Preliminary specification was first issued.
2.0	Mar, 22, 07	All	All	Approval specification was first issued.
2.1	May, 10, 07	16,22	5.5, 6.4	EDID was changed for 8 steps.
2.2	Apr, 25, 08	16	5.5	Update EDID Code to match new part number.

1 GENERAL DESCRIPTION

1.1 OVERVIEW

N141I3 - L05 is a 14.1" TFT Liquid Crystal Display module with single CCFL Backlight unit and 30 pins LVDS interface. This module supports 1280 x 800 WXGA mode and can display 262,144 colors. The optimum viewing angle is at 6 o'clock direction. The inverter module for Backlight is built in.

1.2 FEATURES

- Thin and Light Weight
- WXGA (1280 x 800 pixels) resolution
- DE only mode
- 3.3V LVDS (Low Voltage Differential Signaling) interface with 1 pixel/clock
- RoHS compliance

1.3 APPLICATION

- TFT LCD Notebook

1.4 GENERAL SPECIFICATIONS

Item	Specification	Unit	Note
Active Area	303.36(H) X 189.6(V)	mm	(1)
Bezel Opening Area	306.76 (H) x 193 (V)	mm	
Driver Element	a-si TFT active matrix	-	-
Pixel Number	1280 x R.G.B. x 800	pixel	-
Pixel Pitch	0.237 (H) x 0.237 (V)	mm	-
Pixel Arrangement	RGB vertical stripe	-	-
Display Colors	262,144	color	-
Transmissive Mode	Normally white	-	-
Surface Treatment	Anti-glare , Haze 44,3H	-	-

1.5 MECHANICAL SPECIFICATIONS

Item	Min.	Typ.	Max.	Unit	Note	
Module Size	Horizontal(H)	319	319.5	320	mm	(1)
	Vertical(V)	205	205.5	206	mm	
	Depth(D)	--	5.2	5.5	mm	
Weight	--	435	440	g	(2)	
Weight	--	440	450	g	(3)	

Note (1) Please refer to the attached drawings for more information of front and back outline dimensions

(2) Weight without inverter

(3) Weight with inverter.

2 ABSOLUTE MAXIMUM RATINGS

2.1 ABSOLUTE RATINGS OF ENVIRONMENT

Item	Symbol	Value		Unit	Note
		Min.	Max.		
Storage Temperature	T _{ST}	-20	+60	°C	(1)
Operating Ambient Temperature	T _{OP}	0	+50	°C	(1), (2)
Shock (Non-Operating)	S _{NOP}	-	220/2	G/ms	(3), (5)
Vibration (Non-Operating)	V _{NOP}	-	1.5	G	(4), (5)

Note (1) Temperature and relative humidity range is shown in the figure below.

- (a) 90 %RH Max. ($T_a \leq 40$ °C).
- (b) Wet-bulb temperature should be 39 °C Max. ($T_a > 40$ °C).
- (c) No condensation.

Note (2) The ambient temperature means the temperature of panel surface.

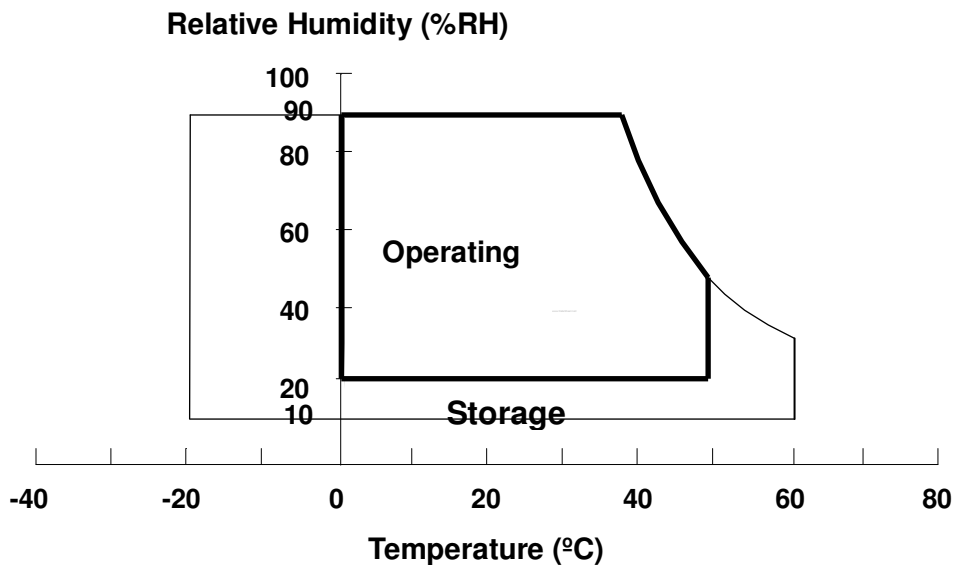

Note (3) 1 time for $\pm X, \pm Y, \pm Z$. for Condition (220G / 2ms) is half Sine Wave.

Note (4) 10 ~ 500 Hz, 30 min / Cycle, 1 cycles for each X, Y, Z axis.

Note (5) At testing Vibration and Shock, the fixture in holding the module has to be hard and rigid enough so that the module would not be twisted or bent by the fixture.

The fixing condition is shown as below:

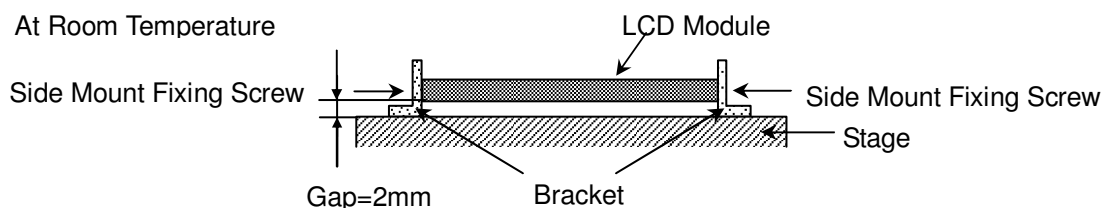

2.2 ELECTRICAL ABSOLUTE RATINGS

2.2.1 TFT LCD MODULE

Item	Symbol	Value		Unit	Note
		Min.	Max.		
Power Supply Voltage	V_{CC}	-0.3	+4.0	V	(1)
Logic Input Voltage	V_{IN}	-0.3	$V_{CC}+0.3$	V	

2.2.2 BACKLIGHT UNIT

Item	Symbol	Value		Unit	Note
		Min.	Max.		
Lamp Voltage	V_L	-	2.5K	V_{RMS}	(1), (2), $I_L = 6.0 \text{ mA}$
Lamp Current	I_L	2.0	6.5	mA_{RMS}	(1), (2)
Lamp Frequency	F_L	45	80	KHz	

Note (1) Permanent damage to the device may occur if maximum values are exceeded. Function operation should be restricted to the conditions described under Normal Operating Conditions.

Note (2) Specified values are for lamp (Refer to 3.2 for further information).

3 ELECTRICAL CHARACTERISTICS

3.1 TFT LCD MODULE

Ta = 25 ± 2 °C

Parameter	Symbol	Value			Unit	Note
		Min.	Typ.	Max.		
Power Supply Voltage	V _{CC}	3.0	3.3	3.6	V	-
Permissible Ripple Voltage	V _{RP}		50		mV	-
Rush Current	I _{RUSH}			1.5	A	(2)
Initial Stage Current	I _{IS}			1.0	A	(2)
Power Supply Current	I _{CC}	White	335	375	mA	(3)a
		Black	400	450	mA	(3)b
LVDS Differential Input High Threshold	V _{TH(LVDS)}			+100	mV	(5), V _{CM} =1.2V
LVDS Differential Input Low Threshold	V _{TL(LVDS)}	-100			mV	(5) V _{CM} =1.2V
LVDS Common Mode Voltage	V _{CM}	1.125		1.375	V	(5)
LVDS Differential Input Voltage	V _{ID}	100		600	mV	(5)
Terminating Resistor	R _T		100		Ohm	
Power per EBL WG	P _{EBL}	-	3.38	-	W	(4)

Note (1) The ambient temperature is Ta = 25 ± 2 °C.

Note (2) I_{RUSH}: the maximum current when V_{CC} is rising

I_{IS}: the maximum current of the first 100ms after power-on

Measurement Conditions: Shown as the following figure. Test pattern: black

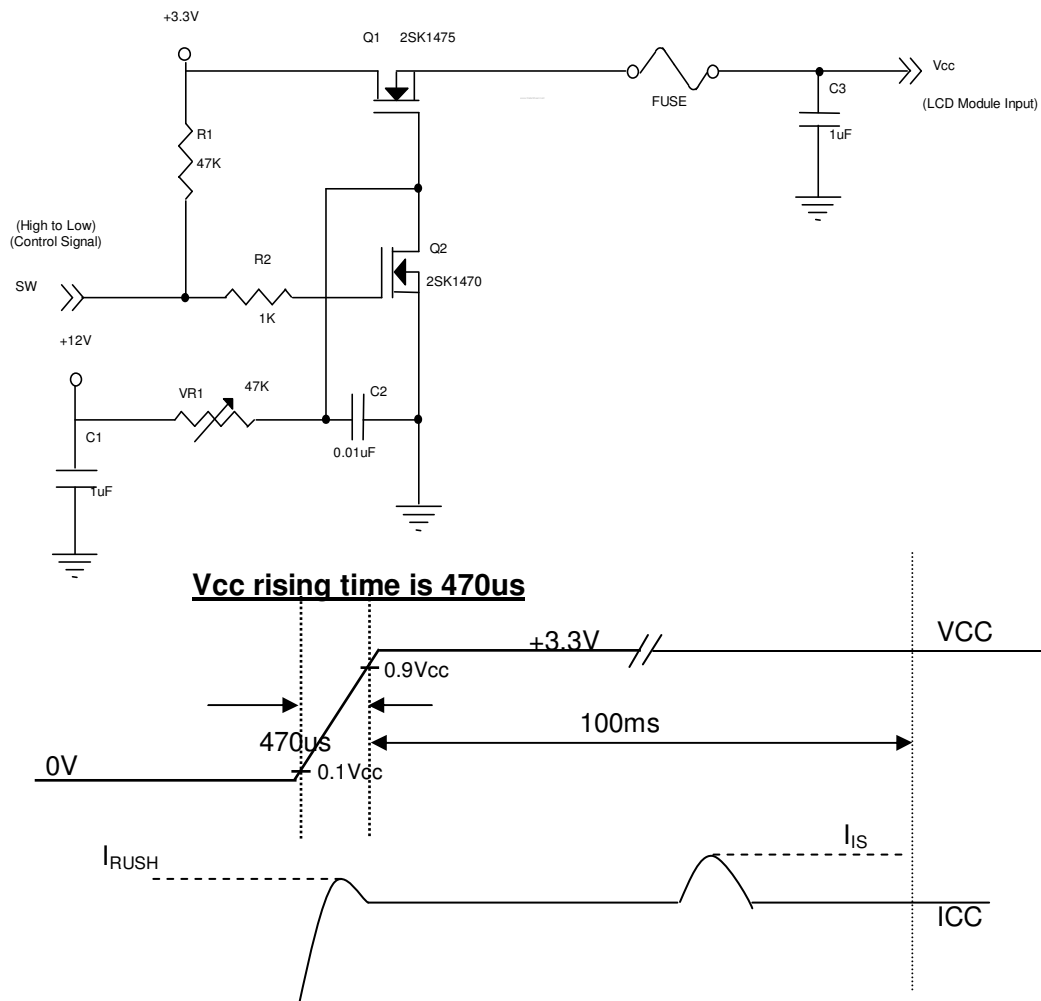

Note (3) The specified power supply current is under the conditions at $V_{CC} = 3.3\text{ V}$, $T_a = 25 \pm 2\text{ }^\circ\text{C}$, $f_v = 60\text{ Hz}$, whereas a power dissipation check pattern below is displayed.

a. White Pattern

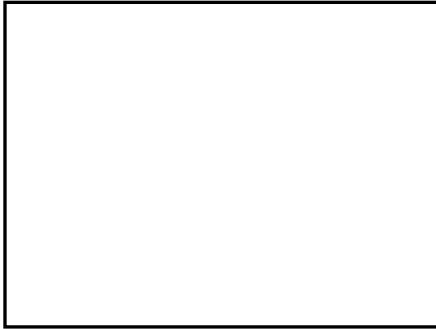

Active Area

b. Black Pattern



Active Area

Note (4) The specified power are the sum of LCD panel electronics input power and the inverter input power. Test conditions are as follows.

- (a) $V_{CC} = 3.3\text{ V}$, $T_a = 25 \pm 2\text{ }^\circ\text{C}$, $f_v = 60\text{ Hz}$,
- (b) The pattern used is a black and white 32 x 36 checkerboard, slide #100 from the VESA file "Flat Panel Display Monitor Setup Patterns", FPDMSU.ppt.
- (c) Luminance: 60 nits.
- (d) The inverter used is provided from Sumida. Please contact them for detail information. CMO doesn't provide the inverter in this product.

Note (5) The parameters of LVDS signals are defined as the following figures.

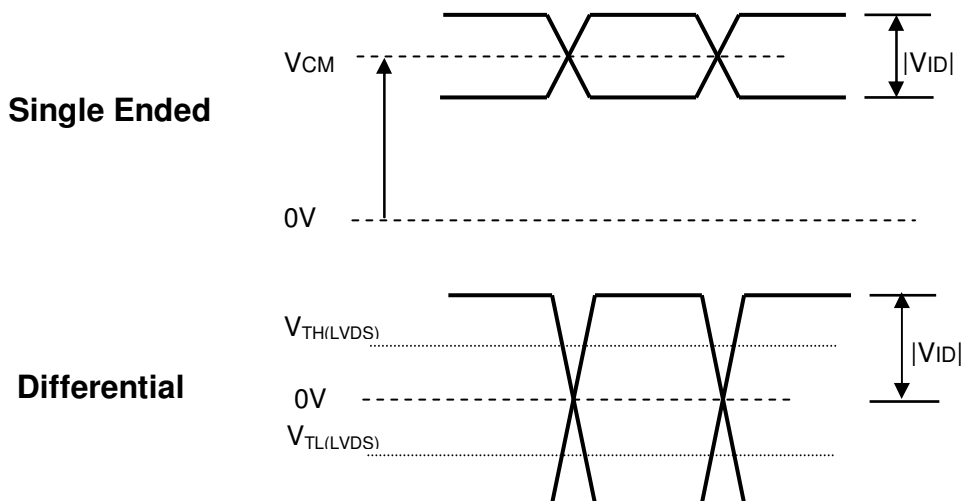

3.2 BACKLIGHT UNIT

Ta = 25 ± 2 °C

Parameter	Symbol	Value			Unit	Note
		Min.	Typ.	Max.		
Lamp Input Voltage	V _L	612	680	748	V _{RMS}	I _L = 6.0 mA
Lamp Current	I _L	2.0	6.0	6.5	mA _{RMS}	(1)
Lamp Turn On Voltage	V _S	---	---	1370 (25 °C)	V _{RMS}	(2)
		---	---	1520 (0 °C)	V _{RMS}	(2)
Operating Frequency	F _L	45	---	80	KHz	(3)
Lamp Life Time	L _{BL}	15,000	---	---	Hrs	(5)
Power Consumption	P _{BL}	-	---	5.7	W	(4)

Note (1) Lamp current is measured by utilizing a high frequency current meter as shown below:

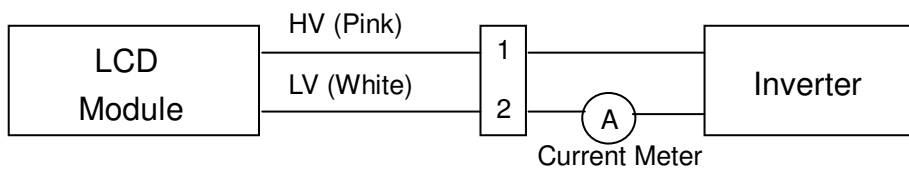

Note (2) The voltage that must be larger than V_S should be applied to the lamp for more than 1 second after startup. Otherwise the lamp may not be turned on.

Note (3) The lamp frequency may produce interference with horizontal synchronous frequency from the display, and this may cause line flow on the display. In order to avoid interference, the lamp frequency should be detached from the horizontal synchronous frequency and its harmonics as far as possible.

Note (4) P_{BL} = Inverter input power

Inverter input power is measured at 8th step (the max brightness step) @Vin=12V

Note (5) The lifetime of lamp can be defined as the time in which it continues to operate under the condition Ta = 25 ± 2 °C and I_L = 6 mA_{RMS} until one of the following events occurs:

- (a) When the brightness becomes or lower than 50% of its original value.
- (b) When the effective ignition length becomes or lower than 80% of its original value. (Effective ignition length is defined as an area that has less than 70% brightness compared to the brightness in the center point.)

Note (6) The waveform of the voltage output of inverter must be area-symmetric and the design of the inverter must have specifications for the modularized lamp. The performance of the Backlight, such as lifetime or brightness, is greatly influenced by the characteristics of the DC-AC inverter for the lamp. All the parameters of an inverter should be carefully designed to avoid producing too much current leakage from high voltage output of the inverter. When designing or ordering the inverter please make sure that a poor lighting caused by the mismatch of the Backlight and the inverter (miss-lighting, flicker, etc.) never occurs. If the above situation is confirmed, the module should be operated in the same manners when it is installed in your instrument.

The output of the inverter must have symmetrical (negative and positive) voltage waveform and

symmetrical current waveform. (Unsymmetrical ratio is less than 10%) Please do not use the inverter which has unsymmetrical voltage and unsymmetrical current and spike wave. Lamp frequency may produce interference with horizontal synchronous frequency and as a result this may cause beat on the display. Therefore lamp frequency shall be as away possible from the horizontal synchronous frequency and from its harmonics in order to prevent interference.

Requirements for a system inverter design, which is intended to have a better display performance, a better power efficiency and a more reliable lamp. It shall help increase the lamp lifetime and reduce its leakage current.

- a. The asymmetry rate of the inverter waveform should be 10% below.
- b. The distortion rate of the waveform should be within $\sqrt{2} \pm 10\%$.
- c. The ideal sine wave form shall be symmetric in positive and negative polarities.

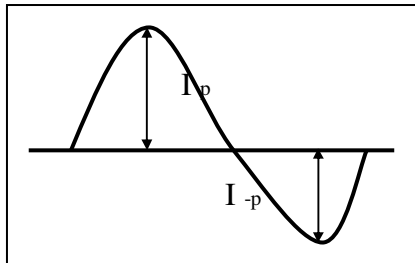

* Asymmetry rate:

$$\frac{|I_p - I_{-p}|}{I_{rms}} * 100\%$$

* Distortion rate

$$I_p \text{ (or } I_{-p}) / I_{rms}$$

4 BLOCK DIAGRAM

4.1 TFT LCD MODULE

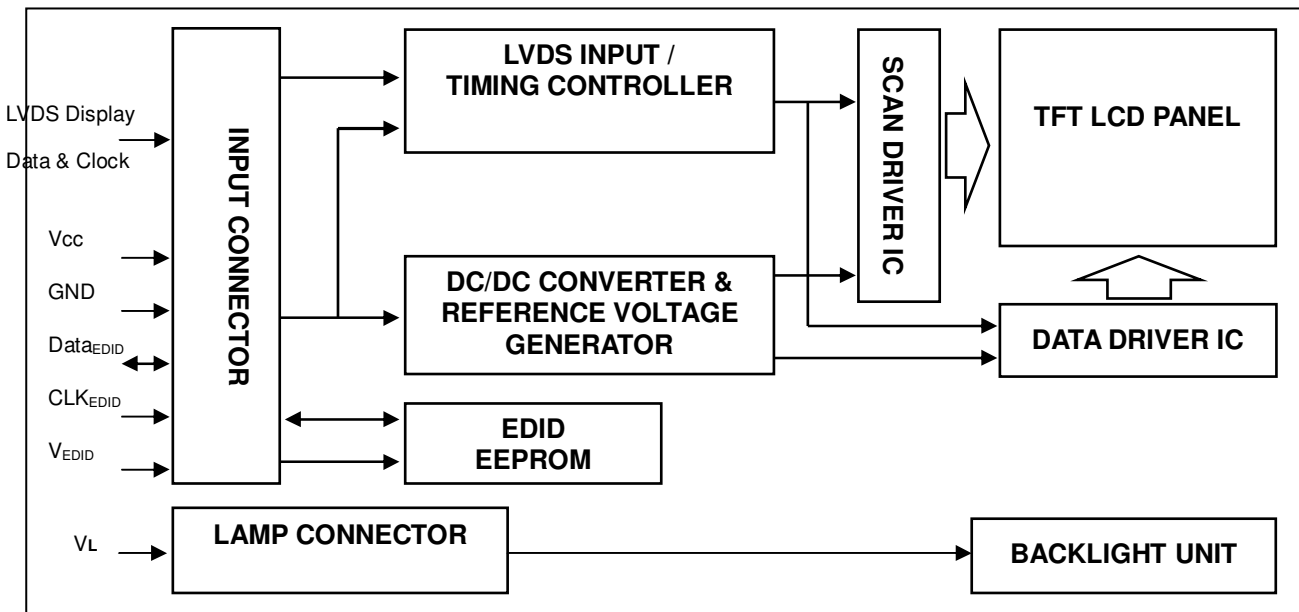

4.2 BACKLIGHT UNIT

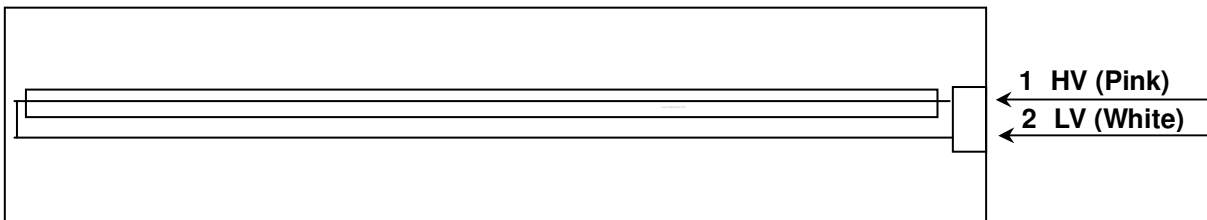

5 INPUT TERMINAL PIN ASSIGNMENT

5.1 TFT LCD MODULE

Pin	Symbol	Description	Polarity	Remark
1	Vss	Ground		
2	Vcc	Power Supply +3.3 V (typical)		
3	Vcc	Power Supply +3.3 V (typical)		
4	V _{EDID}	DDC 3.3V Power		DDC 3.3V Power
5	BIST	Panel BIST enable		
6	CLK _{EDID}	DDC Clock		DDC Clock
7	DATA _{EDID}	DDC Data		DDC Data
8	Rxin0-	LVDS Differential Data Input	Negative	R0~R5, G0
9	Rxin0+	LVDS Differential Data Input	Positive	
10	Vss	Ground		
11	Rxin1-	LVDS Differential Data Input	Negative	G1~G5, B0, B1
12	Rxin1+	LVDS Differential Data Input	Positive	
13	Vss	Ground		
14	Rxin2-	LVDS Differential Data Input	Negative	B2~B5, DE, Hsync, Vsync
15	Rxin2+	LVDS Differential Data Input	Positive	
16	Vss	Ground		
17	CLK-	LVDS Clock Data Input	Negative	LVDS Level Clock
18	CLK+	LVDS Clock Data Input	Positive	
19	Vss	Ground		
20	NC	Non-Connection		
21	NC	Non-Connection		
22	NC	Non-Connection		
23	NC	Non-Connection		
24	NC	Non-Connection		
25	NC	Non-Connection		
26	NC	Non-Connection		
27	NC	Non-Connection		
28	NC	Non-Connection		
29	NC	Non-Connection		
30	NC	Non-Connection		

Note (1) Connector Part No.: JAE-FI-XB30SRL-HF11 or equivalent

Note (2) User's connector Part No: FI-X30M or equivalent

Note (3) The first pixel is odd as shown in the following figure.

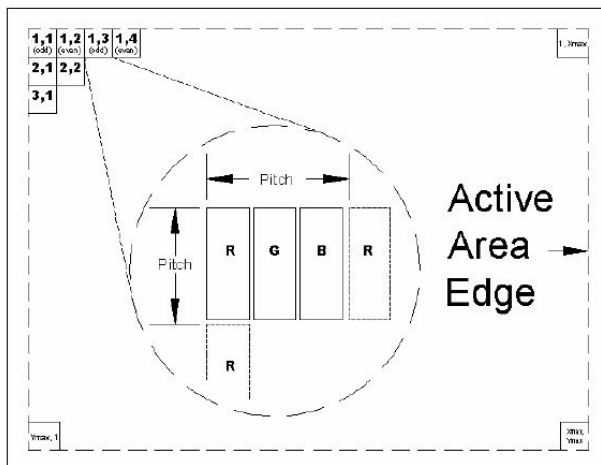

5.2 BACKLIGHT UNIT

Pin	Symbol	Description	Color
1	HV	High Voltage	Pink
2	LV	Ground	White

Note (1) Connector Part No.: JST- BHSR-02VS-1 or equivalent

Note (2) User's connector Part No.: SM02B-BHSS-1-TB or equivalent

5.3 TIMING DIAGRAM OF LVDS INPUT SIGNAL

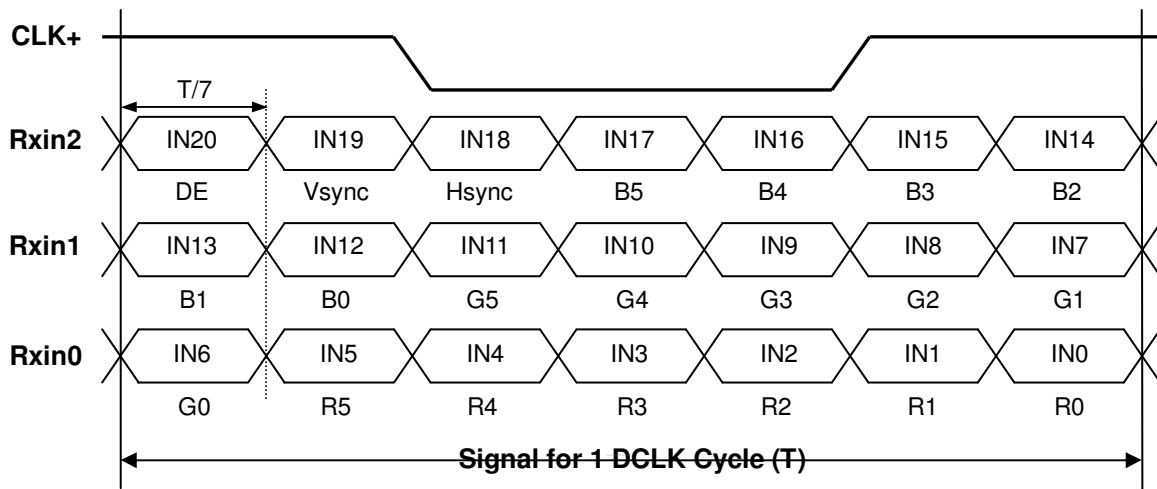

5.4 COLOR DATA INPUT ASSIGNMENT

The brightness of each primary color (red, green and blue) is based on the 6-bit gray scale data input for the color. The higher the binary input, the brighter the color. The table below provides the assignment of color versus data input.

Color		Data Signal																	
		Red						Green						Blue					
		R5	R4	R3	R2	R1	R0	G5	G4	G3	G2	G1	G0	B5	B4	B3	B2	B1	B0
Basic Colors	Black	0	0	0	0	0	0	0	0	0	0	0	0	0	0	0	0	0	0
	Red	1	1	1	1	1	1	0	0	0	0	0	0	0	0	0	0	0	0
	Green	0	0	0	0	0	0	1	1	1	1	1	1	0	0	0	0	0	0
	Blue	0	0	0	0	0	0	0	0	0	0	0	0	1	1	1	1	1	1
	Cyan	0	0	0	0	0	0	1	1	1	1	1	1	1	1	1	1	1	1
	Magenta	1	1	1	1	1	1	0	0	0	0	0	0	1	1	1	1	1	1
	Yellow	1	1	1	1	1	1	1	1	1	1	1	1	0	0	0	0	0	0
	White	1	1	1	1	1	1	1	1	1	1	1	1	1	1	1	1	1	1
Gray Scale Of Red	Red(0)/Dark	0	0	0	0	0	0	0	0	0	0	0	0	0	0	0	0	0	0
	Red(1)	0	0	0	0	0	1	0	0	0	0	0	0	0	0	0	0	0	0
	Red(2)	0	0	0	0	1	0	0	0	0	0	0	0	0	0	0	0	0	0
	:	:	:	:	:	:	:	:	:	:	:	:	:	:	:	:	:	:	:
	:	:	:	:	:	:	:	:	:	:	:	:	:	:	:	:	:	:	:
	:	:	:	:	:	:	:	:	:	:	:	:	:	:	:	:	:	:	:
	Red(61)	1	1	1	1	0	1	0	0	0	0	0	0	0	0	0	0	0	0
	Red(62)	1	1	1	1	1	0	0	0	0	0	0	0	0	0	0	0	0	0
Red(63)	1	1	1	1	1	1	0	0	0	0	0	0	0	0	0	0	0	0	
Gray Scale Of Green	Green(0)/Dark	0	0	0	0	0	0	0	0	0	0	0	0	0	0	0	0	0	0
	Green(1)	0	0	0	0	0	0	0	0	0	0	0	1	0	0	0	0	0	0
	Green(2)	0	0	0	0	0	0	0	0	0	0	1	0	0	0	0	0	0	0
	:	:	:	:	:	:	:	:	:	:	:	:	:	:	:	:	:	:	:
	:	:	:	:	:	:	:	:	:	:	:	:	:	:	:	:	:	:	:
	:	:	:	:	:	:	:	:	:	:	:	:	:	:	:	:	:	:	:
	Green(61)	0	0	0	0	0	0	1	1	1	1	0	1	0	0	0	0	0	0
	Green(62)	0	0	0	0	0	0	1	1	1	1	1	0	0	0	0	0	0	0
Green(63)	0	0	0	0	0	0	1	1	1	1	1	1	0	0	0	0	0	0	
Gray Scale Of Blue	Blue(0)/Dark	0	0	0	0	0	0	0	0	0	0	0	0	0	0	0	0	0	0
	Blue(1)	0	0	0	0	0	0	0	0	0	0	0	0	0	0	0	0	0	1
	Blue(2)	0	0	0	0	0	0	0	0	0	0	0	0	0	0	0	0	1	0
	:	:	:	:	:	:	:	:	:	:	:	:	:	:	:	:	:	:	:
	:	:	:	:	:	:	:	:	:	:	:	:	:	:	:	:	:	:	:
	:	:	:	:	:	:	:	:	:	:	:	:	:	:	:	:	:	:	:
	Blue(61)	0	0	0	0	0	0	0	0	0	0	0	0	1	1	1	1	0	1
	Blue(62)	0	0	0	0	0	0	0	0	0	0	0	0	1	1	1	1	1	0
Blue(63)	0	0	0	0	0	0	0	0	0	0	0	0	1	1	1	1	1	1	

Note (1) 0: Low Level Voltage, 1: High Level Voltage

5.5 EDID DATA STRUCTURE

The EDID (Extended Display Identification Data) data formats are to support displays as defined in the VESA Plug & Display and FPD standards.

Byte # (decimal)	Byte # (hex)	Field Name and Comments	Value (hex)	Value (binary)
0	0	Header	00	00000000
1	1	Header	FF	11111111
2	2	Header	FF	11111111
3	3	Header	FF	11111111
4	4	Header	FF	11111111
5	5	Header	FF	11111111
6	6	Header	FF	11111111
7	7	Header	00	00000000
8	8	EISA ID manufacturer name ("CMO")	0D	00001101
9	9	EISA ID manufacturer name (Compressed ASCII)	AF	10101111
10	0A	ID product code (N141I3-L05)	26	00100110
11	0B	ID product code (hex LSB first; N141I3-L05)	14	00010100
12	0C	ID S/N (fixed "0")	00	00000000
13	0D	ID S/N (fixed "0")	00	00000000
14	0E	ID S/N (fixed "0")	00	00000000
15	0F	ID S/N (fixed "0")	00	00000000
16	10	Week of manufacture (fixed week code)	0C	00001100
17	11	Year of manufacture (fixed year code)	11	00010001
18	12	EDID structure version # ("1")	01	00000001
19	13	EDID revision # ("3")	03	00000011
20	14	Video I/P definition ("digital")	80	10000000
21	15	Active area horizontal 30.336cm	1E	00011110
22	16	Active area vertical 18.96cm	13	00010011
23	17	Display Gamma (Gamma = "2.2")	78	01111000
24	18	Feature support ("Active off, RGB Color")	0A	00001010
25	19	Rx1 Rx0 Ry1 Ry0 Gx1 Gx0 Gy1 Gy0	47	01000111
26	1A	Bx1 Bx0 By1 By0 Wx1 Wx0 Wy1 Wy0	A0	10100000
27	1B	Rx=0.58	94	10010100
28	1C	Ry=0.34	57	01010111
29	1D	Gx=0.31	4F	01001111
30	1E	Gy=0.55	8C	10001100
31	1F	Bx=0.155	27	00100111
32	20	By=0.155	27	00100111
33	21	Wx=0.313	50	01010000
34	22	Wy=0.329	54	01010100
35	23	Established timings 1	00	00000000
36	24	Established timings 2 (1280*800@60Hz)	00	00000000
37	25	Manufacturer's reserved timings	00	00000000
38	26	Standard timing ID # 1	01	00000001
39	27	Standard timing ID # 1	01	00000001
40	28	Standard timing ID # 2	01	00000001
41	29	Standard timing ID # 2	01	00000001

42	2A	Standard timing ID # 3	01	00000001
43	2B	Standard timing ID # 3	01	00000001
44	2C	Standard timing ID # 4	01	00000001
45	2D	Standard timing ID # 4	01	00000001
46	2E	Standard timing ID # 5	01	00000001
47	2F	Standard timing ID # 5	01	00000001
48	30	Standard timing ID # 6	01	00000001
49	31	Standard timing ID # 6	01	00000001
50	32	Standard timing ID # 7	01	00000001
51	33	Standard timing ID # 7	01	00000001
52	34	Standard timing ID # 8	01	00000001
53	35	Standard timing ID # 8	01	00000001
54	36	Detailed timing description # 1 Pixel clock ("71.4MHz", According to VESA CVT Rev1.1)	E4	11100100
55	37	# 1 Pixel clock (hex LSB first)	1B	00011011
56	38	# 1 H active ("1280")	00	00000000
57	39	# 1 H blank ("165")	A5	10100101
58	3A	# 1 H active : H blank ("1280 : 165")	50	01010000
59	3B	# 1 V active ("800")	20	00100000
60	3C	# 1 V blank ("23")	17	00010111
61	3D	# 1 V active : V blank ("800 : 23")	30	00110000
62	3E	# 1 H sync offset ("48")	30	00110000
63	3F	# 1 H sync pulse width ("32")	20	00100000
64	40	# 1 V sync offset : V sync pulse width ("3 : 6")	36	00110110
65	41	# 1 H sync offset : H sync pulse width : V sync offset : V sync width ("48: 32 : 3 : 6")	00	00000000
66	42	# 1 H image size ("303 mm")	2F	00101111
67	43	# 1 V image size ("190 mm")	BE	10111110
68	44	# 1 H image size : V image size ("303 : 190")	10	00010000
69	45	# 1 H boarder ("0")	00	00000000
70	46	# 1 V boarder ("0")	00	00000000
71	47	# 1 Non-interlaced, Normal, no stereo, Separate sync, H/V pol Negatives	19	00011001
72	48	Detailed timing description # 2 Pixel clock ("0 MHz")	00	00000000
73	49	# 2 Pixel clock (hex LSB first)	00	00000000
74	4A	# 2 H active ("0")	00	00000000
75	4B	# 2 H blank ("0")	00	00000000
76	4C	# 2 H active : H blank ("0 : 0")	00	00000000
77	4D	# 2 V active ("0")	00	00000000
78	4E	# 2 V blank ("0")	00	00000000
79	4F	# 2 V active : V blank ("0 : 0")	00	00000000
80	50	# 2 H sync offset ("0")	00	00000000
81	51	# 2 H sync pulse width ("0")	00	00000000
82	52	# 2 V sync offset : V sync pulse width ("0 : 0")	00	00000000
83	53	# 2 H sync offset : H sync pulse width : V sync offset : V sync width ("0 : 0 : 0 : 0")	00	00000000
84	54	# 2 H image size ("0 mm")	00	00000000
85	55	# 2 V image size ("0 mm")	00	00000000

86	56	# 2 H image size : V image size ("0 : 0")	00	00000000
87	57	# 2 H boarder ("0")	00	00000000
88	58	# 2 V boarder ("0")	00	00000000
89	59	Module "A" Revision = Example: 00, 01, 02, 03, etc.	00	00000000
90	5A	Detailed timing description # 3	00	00000000
91	5B	# 3 Flag	00	00000000
92	5C	# 3 Reserved	00	00000000
93	5D	# 3 FE (hex) defines ASCII string (Model Name "N141I3", ASCII)	FE	11111110
94	5E	# 3 Flag	00	00000000
95	5F	# Dell P/N " R767G" 1st character ("R")	52	01010010
96	60	# Dell P/N " R767G" 1st character ("7")	37	00110111
97	61	# Dell P/N " R767G" 1st character ("6")	36	00110110
98	62	# Dell P/N " R767G" 1st character ("7")	37	00110111
99	63	# Dell P/N " R767G" 1st character ("G")	47	01000111
100	64	LCD Supplier EEDID Revision #: "7"	38	00111000
101	65	Manufacturer P/N ("N")	4E	01001110
102	66	Manufacturer P/N ("1")	31	00110001
103	67	Manufacturer P/N ("4")	34	00110100
104	68	Manufacturer P/N ("1")	31	00110001
105	69	Manufacturer P/N ("I")	49	01001001
106	6A	Manufacturer P/N ("3")	33	00110011
107	6B	Manufacturer P/N (If <13 char, then terminate with ASCII code 0Ah, set remaining char = 20h)	0A	00001010
108	6C	Flag	00	00000000
109	6D	Flag	00	00000000
110	6E	Flag	00	00000000
111	6F	Data Type Tag:	FE	11111110
112	70	Flag	00	00000000
113	71	SMBUS value @ 10nits = 44d	2C	00101100
114	72	SMBUS value @ 17nits = 64d	40	01000000
115	73	SMBUS value @ 24nits = 77d	4D	01001101
116	74	SMBUS value @ 30nits = 86d	56	01010110
117	75	SMBUS value @ 60nits = 122d	7A	01111010
118	76	SMBUS value @ 100nits = 159d	9F	10011111
119	77	SMBUS value @ 160nits = 219d	DB	11011011
120	78	SMBUS value @ max nits = 255d	FF	11111111
121	79	Numbers of LVDS Receiver chip = 1	01	00000001
122	7A	BIST Enable: Yes = '01' No = '00' ("Yes")	01	00000001
123	7B	(If <13 char, then terminate with ASCII code 0Ah, set remaining char = 20h)	0A	00001010
124	7C	(If <13 char, then terminate with ASCII code 0Ah, set remaining char = 20h)	20	00100000
125	7D	(If <13 char, then terminate with ASCII code 0Ah, set remaining char = 20h)	20	00100000
126	7E	Extension flag	00	00000000
127	7F	Checksum	ED	11101101

6 INVERTER SPECIFICATION

6.1 Connector type

Input connector type: **LVC-D20SFYG** (HONDA)

Output connector: **JST SM02B-BHSS-1-TB** (JST)

6.2 Input connector pin assignment

Input Connector pin assignment:

Input connector		Comments
HONDA	LVC-D20SFYG	
Pin	Function	
1	INV_SRC	This power rail should be used as a power rail to drive the backlight DC-AC converter
2	INV_SRC	This power rail should be used as a power rail to drive the backlight DC-AC converter
3	INV_SRC	This power rail should be used as a power rail to drive the backlight DC-AC converter
4	INV_SRC	This power rail should be used as a power rail to drive the backlight DC-AC converter
5	GND	Ground
6	NC	No Connection
7	5VALW	This should be used as power source that stores the brightness/contrast values & the circuit that interfaces with SMB_CLK & SMB_DAT
8	GND	Ground
9	SMB_DAT	SMBus interface for sending brightness & contrast information to the inverter/panel
10	SMB_CLK	SMBus interface for sending brightness & contrast information to the inverter/panel
11	GND	Ground
12	INV_PWM	System side PWM input signal for brightness control
13	GND	Ground
14	NC	No Connection
15	DIAG_LOOP	Diag pin for Dell testing. Pin15 & 20 must be connected electrically on the inverter board.
16	GND	Ground
17	5VALW	This should be used as power source that stores the brightness/contrast values & the circuit that interfaces with SMB_CLK & SMB_DAT
18	5VALW	This should be used as power source that stores the brightness/contrast values & the circuit that interfaces with SMB_CLK & SMB_DAT
19	NC	No Connection
20	DIAG_LOOP	Diag pin for Dell testing. Pin15 & 20 must be connected electrically on the inverter board.

6.2.1 Absolute maximum ratings

Items	Absolute max. ratings	Unit
INV_SRC (Voltage)	-1.0~23.5	V
FPBACK/SMB_CLK/SMB_DAT (Voltage)	-1.0~5.5	V

6.3 Output connector pin assignment

Pin	Name	Description
1	CFL-High	High-voltage output to the CCFL
2	CFL-Low	Low-voltage output to the CCFL

6.4 General electrical specification:

6.4.1 Absolute maximum ratings

Items	Absolute max. ratings	Unit
INV_SRC (Voltage)	-1.0~23.5	V
FPBACK/SMB_CLK/SMB_DAT (Voltage)	-1.0~5.5	V

6.4.2 Electrical characteristics:

No.	Item	Symbol	Condition	Min.	Typ.	Max.	Unit
1	Input Voltage	INV_SRC	—	7.5	14.4	21	V
2	Input Signal Level for 5VSUS	5VSUS		4.85	5	5.2	V
3	Input Signal Level for 5VALW	5VALW		4.85	5	5.2	V
4	Input Power	Pin(Max)	Vin=7.5V~21V SMB_DAT=FFH	--	--	5.7	W
5	Lamp Power	Po	Vin=7.5V~21V SMB_DAT=FFH	--	--	4.9	W
6	Backlight ON/OFF Control	FPBACK=ON	Enable the inverter	2.0	-	5.25	V
		FPBACK=OFF	Disable the inverter	-0.3	-	0.8	V
7	Brightness Adjust (Lamp Current Control)	SMB_DAT	Control by SMBus(256 steps dimming control)	00H	-	FFH	-
8	Output Voltage	Vout	IL = 6.0mA(typ)	612	680	748	Vrms

9	Output Current	I _{out} (Min)	V _{in} =7.5V~21V SMB_DAT=00H T _a =25°C, after running 30 min.	1.5	1.8	2.1	mArms
		I _{out} (Max)	V _{in} =7.5V~21V SMB_DAT=FFH T _a =25°C, after running 30 min.	6.0	6.3	6.6	mArms
10	Operation Frequency	F _{req}	V _{in} =7.5V~21V	45	-	65	KHz
11	Burst mode frequency	f _B	V _{in} =7.5V~21V	200	-	220	Hz
12	Open Lamp Voltage	V _{open}	No Load	1370	--	1520	V _{rms}
13	Striking Time	T _s	No Load	0.6	1	1.4	Sec
14	Efficiency	η	V _{in} =7.5V, SMB_DAT=FFH (RES LOAD=100K ohm)	80	-	-	%
15	Start and Delay Time		V _{in} =14.4V, SMB_DAT=00H	-	130	200	uS
16	Start -up time (Turn on delay time)		V _{in} =14.4V, SMB_DAT=FFH	-	-	0.1	Sec

- Input Voltage
 The operating input voltage of inverter shall be defined.
 The inverter shall ignite the CCFL lamp at minimum input voltage at any environment conditions.
- On/Off control
 Enable: At "ON" condition (FPBACK=Hi), enable the inverter.
 Disable: At "OFF" condition (FPBACK=Lo), disable the inverter.
- Quiescent current
 At the inverter "OFF" condition, input quiescent should be less than 0.1mA.
- Open lamp voltage
 The inverter start-up output voltage will be above "V_{open}" for "T_s" minimum at any condition under specify until lamp to be ignited. The inverter should be shutdown if lamp ignition was failed in "T_s" maximum. The inverter shall be capable of withstanding the output connections open without component over-stress / fire / smoke /arc.
- Burst mode frequency
 The burst mode frequency should be in specification in any environment condition and electrical condition.
- Brightness control
 SM-BUS values for panel luminance are to be included in the on LCD board EEDID ROM chip table. The supplier will measure panel luminance in a system and define the SMBUS values for each of the 8 required luminance levels. The panel luminance, for which SMBUS values will be provided in the EEDID from byte # 113(hex #71), to byte # 120, (hex # 78), is show in the table below. The inverter supplier should provide

these appropriate values to CMO.

Step Count	Step 1	Step 2	Step3	Step 4	Step 5	Step 6	Step 7	Step 8
Address	Byte 113	Byte 114	Byte 115	Byte 116	Byte 117	Byte 118	Byte 119	Byte 120
SM-Bus Data Value	44	64	77	86	122	159	219	255
Luminance (nits)	10	17	24	30	60	100	160	220

- Output ripple ratio

$$\text{Ripple ratio} = 2 * (I_{\text{peak}} - I_{\text{valley}}) / (I_{\text{peak}} + I_{\text{valley}}) * 100\%$$

The Ripple ratio should be less than 5% and ripple frequency should be less than 200 Hz.

- Power up Overshoot & Undershoot

Overshoot & Undershoot at power up should not exceed the following limits.

V _{in}	Output current I _o (rms)	I _o (dI) Overshoot/Undershoot	Settling time (dT)
0→V _{in} (min.)	I _o (max.)	150% / 50%	5 ms max.
	I _o (min.)		
0→V _{in} (typ.)	I _o (max.)	150% / 50%	5 ms max.
	I _o (min.)		
0→V _{in} (max.)	I _o (max.)	150% / 50%	5 ms max.
	I _o (min.)		

$$dI = I_{\text{max.}} - I_{\text{o}} \quad \text{or} \quad dI = (I_{\text{o}} - I_{\text{min.}}) / I_{\text{o}}$$

- Output connections short protection

The inverter shall be capable of withstanding the output connections short without damage or over-stress.

And the inverter maximum input power shall be limited within 1W.

6.4.3 Mechanical Drawing

Please refer to CMO's previous mechanical drawing of appendix (07N2737_mech.pdf)

7 INTERFACE TIMING

7.1 INPUT SIGNAL TIMING SPECIFICATIONS

The specifications of input signal timing are as the following table and timing diagram.

Signal	Item	Symbol	Min.	Typ.	Max.	Unit	Note
DCLK	Frequency	1/Tc	50	71	80	MHz	-
DE	Vertical Total Time	TV	810	823	1023	TH	-
	Vertical Addressing Time	TVD	800	800	800	TH	-
	Horizontal Total Time	TH	1360	1440	1800	Tc	-
	Horizontal Addressing Time	THD	1280	1280	1280	Tc	-

INPUT SIGNAL TIMING DIAGRAM

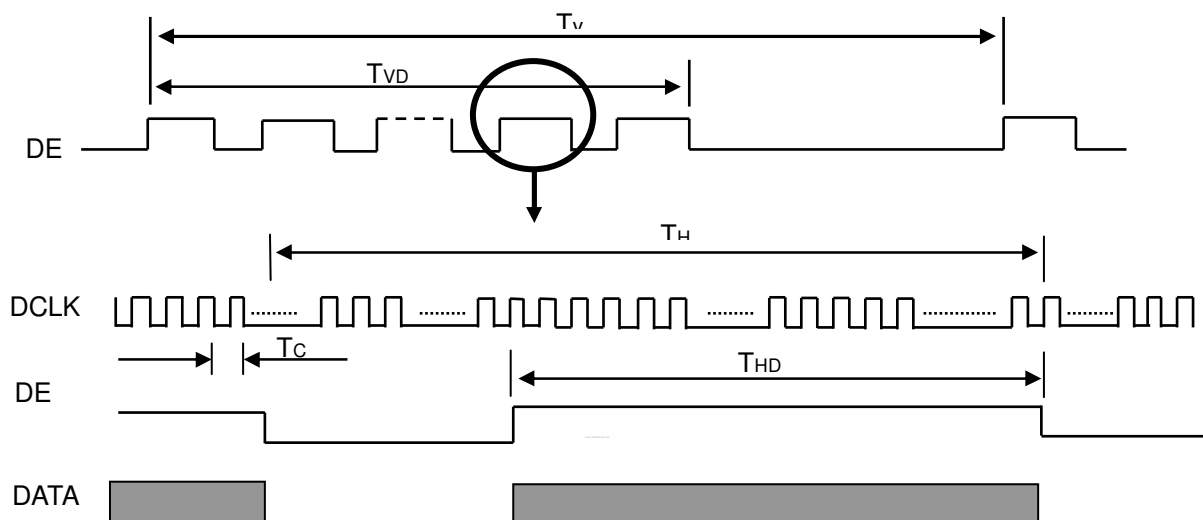

7.2 POWER ON/OFF SEQUENCE

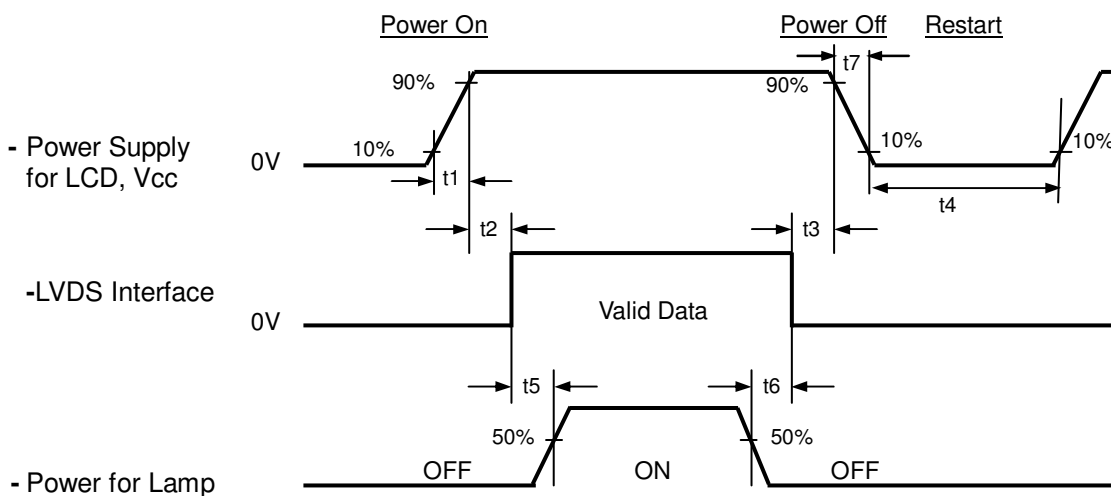

Timing Specifications:

$$0.5 < t1 \leq 10 \text{ msec}$$

$$0 < t2 \leq 50 \text{ msec}$$

$$0 < t3 \leq 50 \text{ msec}$$

$$t4 \geq 500 \text{ msec}$$

$$t5 \geq 200 \text{ msec}$$

$$t6 \geq 200 \text{ msec}$$

Note (1) Please follow the power on/off sequence described above. Otherwise, the LCD module might be damaged.

Note (2) Please avoid floating state of interface signal at invalid period. When the interface signal is invalid, be sure to pull down the power supply of LCD Vcc to 0 V.

Note (3) The Backlight inverter power must be turned on after the power supply for the logic and the interface signal is valid. The Backlight inverter power must be turned off before the power supply for the logic and the interface signal is invalid.

Note (4) Sometimes some slight noise shows when LCD is turned off (even backlight is already off). To avoid this phenomenon, we suggest that the Vcc falling time is better to follow $5 \leq t7 \leq 300 \text{ ms}$

8 OPTICAL CHARACTERISTICS

8.1 TEST CONDITIONS

Item	Symbol	Value	Unit
Ambient Temperature	T _a	25±2	°C
Ambient Humidity	H _a	50±10	%RH
Supply Voltage	V _{CC}	3.3	V
Input Signal	According to typical value in "3. ELECTRICAL CHARACTERISTICS"		
Inverter Current	I _L	6	mA
Inverter Driving Frequency	F _L	61	KHz
Inverter	H05-4915		

The relative measurement methods of optical characteristics are shown in 8.2. The following items should be measured under the test conditions described in 8.1 and stable environment shown in Note (6).

8.2 OPTICAL SPECIFICATIONS

Item		Symbol	Condition	Min.	Typ.	Max.	Unit	Note	
Contrast Ratio		CR	θ _x =0°, θ _y =0° Viewing Normal Angle	300	400	-	-	(2), (5)	
Response Time		T _R		-	3	8	ms	(3)	
		T _F		-	7	12	ms		
Average Luminance of White		L _{5p}		200	220		cd/m ²	(4), (5)	
Luminance Non-Uniformity		δW _{5p}		-	-	20	%	(5), (6)	
		δW _{13p}		-	-	35	%		
Color Gamut		C.G		42	45	-	%	(5), (7)	
Color Chromaticity	Red	R _x		—	TYP -0.02	0.580	TYP +0.02	-	(1), (5)
		R _y				0.340		-	
	Green	G _x				0.310		-	
		G _y	0.550			-			
	Blue	B _x	0.155			-			
		B _y	0.155			-			
	White	W _x	0.313			-			
		W _y	0.329			-			
Viewing Angle	Horizontal	θ _{x+}	CR≥10	40	45	-	Deg.		
		θ _{x-}		40	45	-			
	Vertical	θ _{y+}		15	20	-			
		θ _{y-}		40	45	-			

Note (1) Definition of Viewing Angle (θ_x, θ_y):

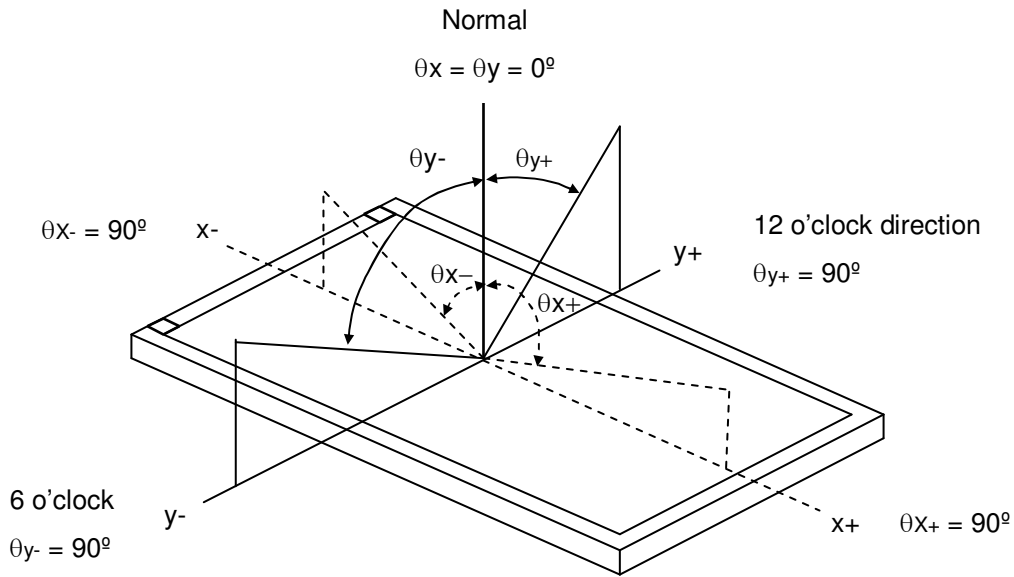

Note (2) Definition of Contrast Ratio (CR):

The contrast ratio can be calculated by the following expression.

$$\text{Contrast Ratio (CR)} = L_{63} / L_0$$

L_{63} : Luminance of gray level 63

L_0 : Luminance of gray level 0

$$\text{CR} = \text{CR} (5)$$

CR (X) is corresponding to the Contrast Ratio of the point X at Figure in Note (6).

Note (3) Definition of Response Time (T_R, T_F):

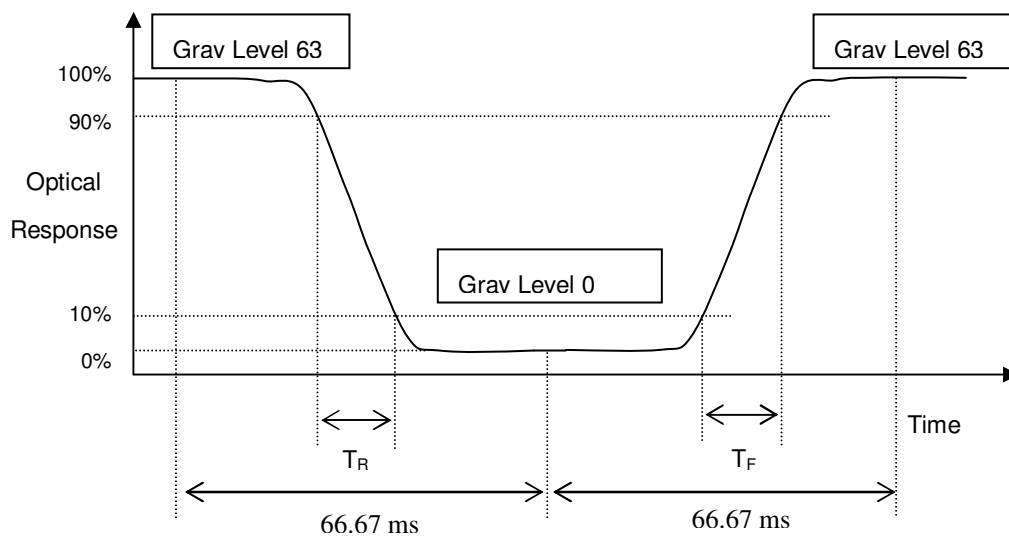

Note (4) Definition of Average Luminance of White (L_{5p}):

Measure the luminance of gray level 63 at 5 points

$$L_{5p} = [L(5) + L(10) + L(11) + L(12) + L(13)] / 5$$

L(x) is corresponding to the luminance of the point X at Figure in Note (6)

Note (5) Measurement Setup:

The LCD module should be stabilized at given temperature for 20 minutes to avoid abrupt temperature change during measuring. In order to stabilize the luminance, the measurement should be executed after lighting Backlight for 20 minutes in a windless room.

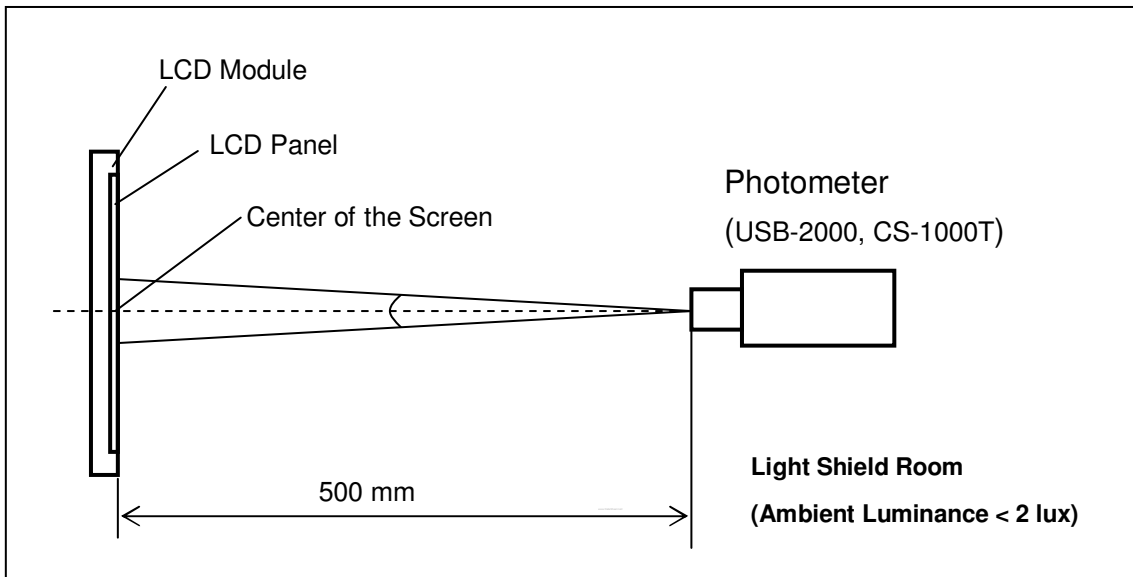

Note (6) Definition of White Variation (δW_{5p} , δW_{13p}):

Measure the luminance of gray level 63 at 5, 13 points

$$\delta W_{5p} = \{1 - \{ \text{Minimum} [L(5) + L(10) + L(11) + L(12) + L(13)] / \text{Maximum} [L(5) + L(10) + L(11) + L(12) + L(13)] \} \} * 100\%$$

$$\delta W_{13p} = \{1 - \{ \text{Minimum} [L(1) \sim L(13)] / \text{Maximum} [L(1) \sim L(13)] \} \} * 100\%$$

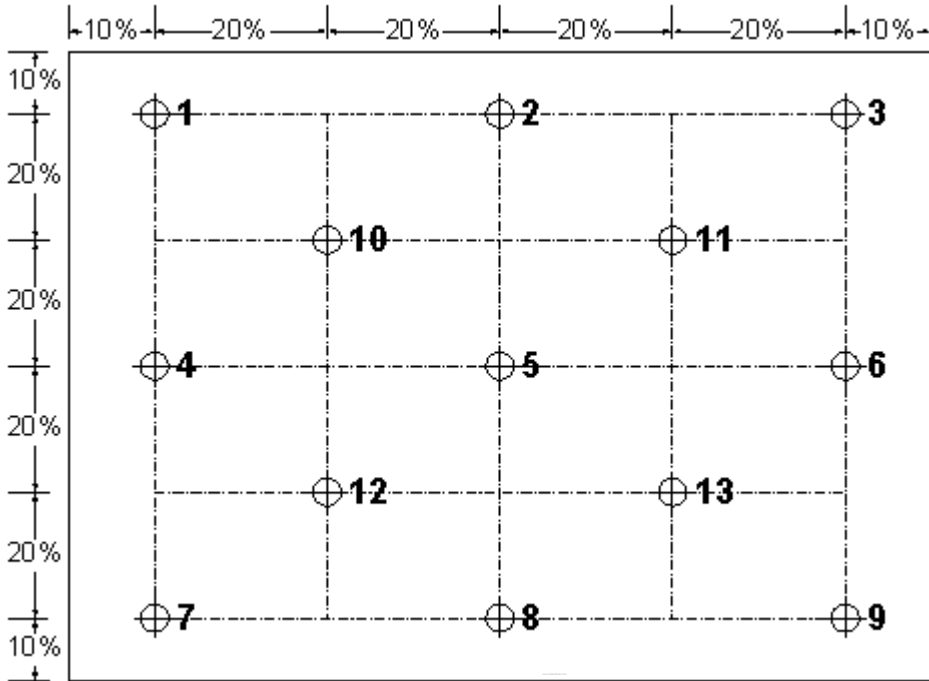

Note (7) Definition of color gamut (C.G):

$$C.G = \Delta R G B / \Delta R_0 G_0 B_0 * 100\%$$

R_0, G_0, B_0 : color coordinates of red, green, and blue defined by NTSC, respectively.

R, G, B : color coordinates of module on 63 gray levels of red, green, and blue, respectively.

$\Delta R_0 G_0 B_0$: area of triangle defined by R_0, G_0, B_0

$\Delta R G B$: area of triangle defined by R, G, B

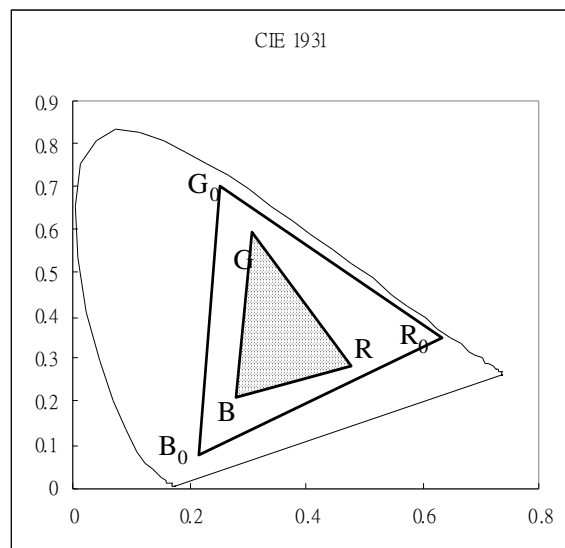

9 PRECAUTIONS

9.1 HANDLING PRECAUTIONS

- (1) The module should be assembled into the system firmly by using every mounting hole. Be careful not to twist or bend the module.
- (2) While assembling or installing modules, it can only be in the clean area. The dust and oil may cause electrical short or damage the polarizer.
- (3) Use fingerstalls or soft gloves in order to keep display clean during the incoming inspection and assembly process.
- (4) Do not press or scratch the surface harder than a HB pencil lead on the panel because the polarizer is very soft and easily scratched.
- (5) If the surface of the polarizer is dirty, please clean it by some absorbent cotton or soft cloth. Do not use Ketone type materials (ex. Acetone), Ethyl alcohol, Toluene, Ethyl acid or Methyl chloride. It might permanently damage the polarizer due to chemical reaction.
- (6) Wipe off water droplets or oil immediately. Staining and discoloration may occur if they left on panel for a long time.
- (7) If the liquid crystal material leaks from the panel, it should be kept away from the eyes or mouth. In case of contacting with hands, legs or clothes, it must be washed away thoroughly with soap.
- (8) Protect the module from static electricity, it may cause damage to the C-MOS Gate Array IC.
- (9) Do not disassemble the module.
- (10) Do not pull or fold the lamp wire.
- (11) Pins of I/F connector should not be touched directly with bare hands.

9.2 STORAGE PRECAUTIONS

- (1) High temperature or humidity may reduce the performance of module. Please store LCD module within the specified storage conditions.
- (2) It is dangerous that moisture come into or contacted the LCD module, because the moisture may damage LCD module when it is operating.
- (3) It may reduce the display quality if the ambient temperature is lower than 10 °C. For example, the response time will become slowly, and the starting voltage of lamp will be higher than the room temperature.

9.3 OPERATION PRECAUTIONS

- (1) Do not pull the I/F connector in or out while the module is operating.
- (2) Always follow the correct power on/off sequence when LCD module is connecting and operating. This can prevent the CMOS LSI chips from damage during latch-up.
- (3) The startup voltage of Backlight is approximately 1000 Volts. It may cause electrical shock while assembling with inverter. Do not disassemble the module or insert anything into the Backlight unit.

10 PACKAGING
 10.1 CARTON

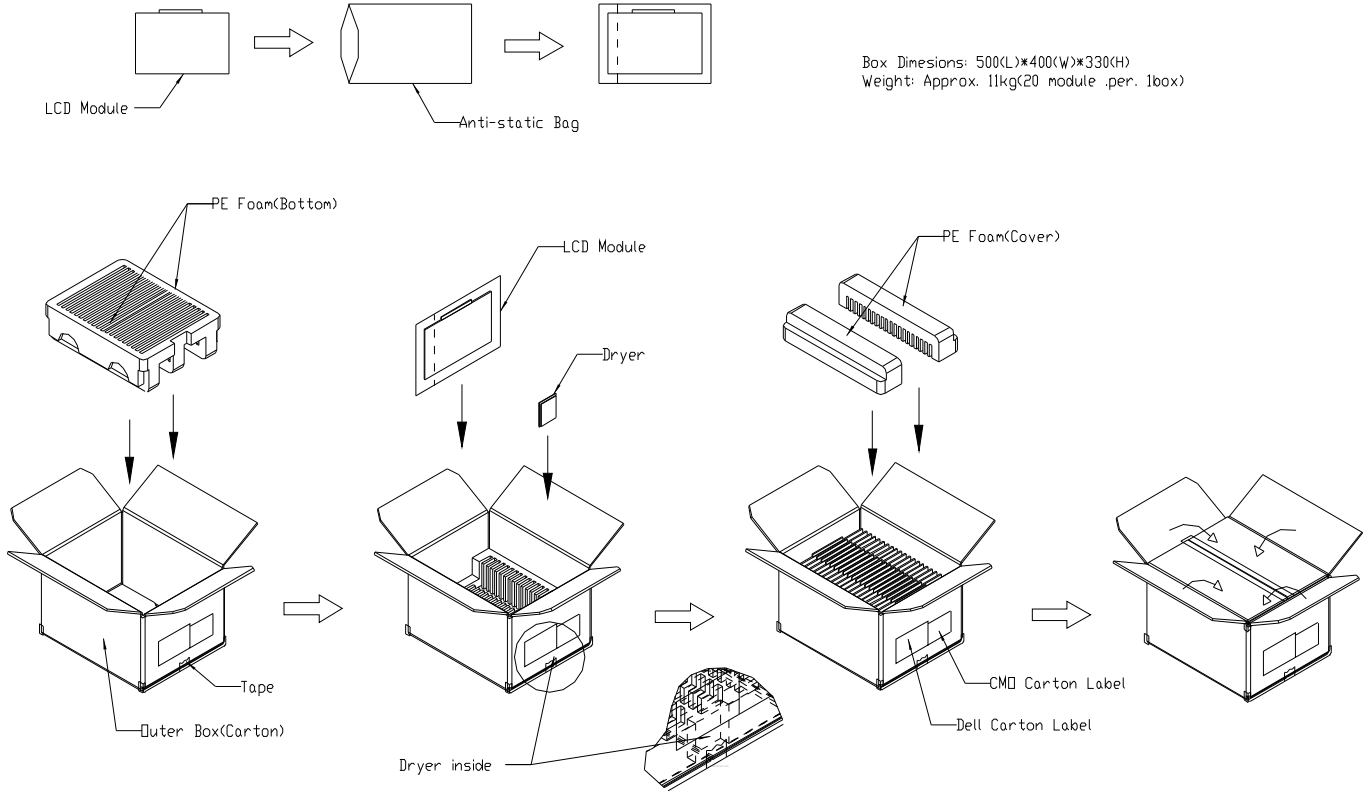

Figure. 10-1 Packing method

10.2 PALLET (For Sea Freight)

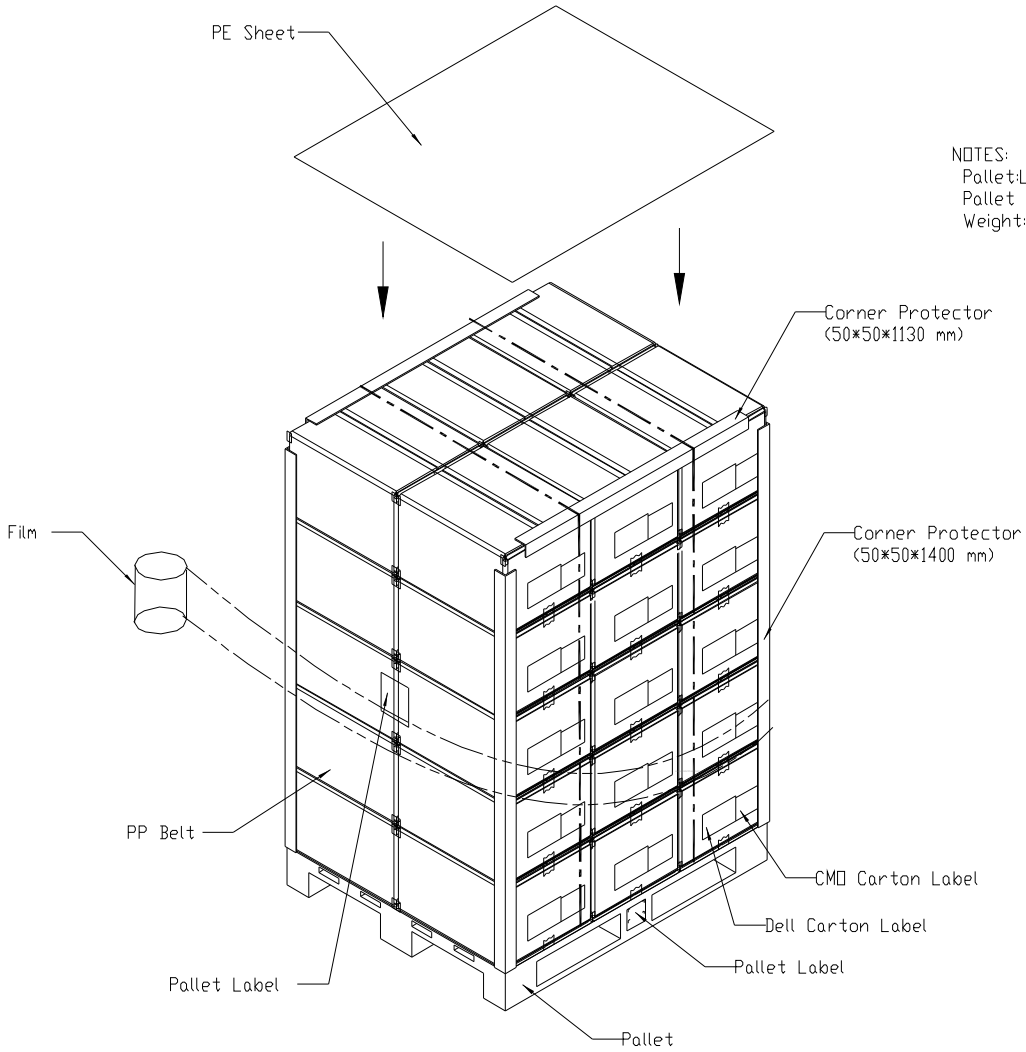

Figure. 10-2 Packing method

10.3 PALLET (For Air Freight)

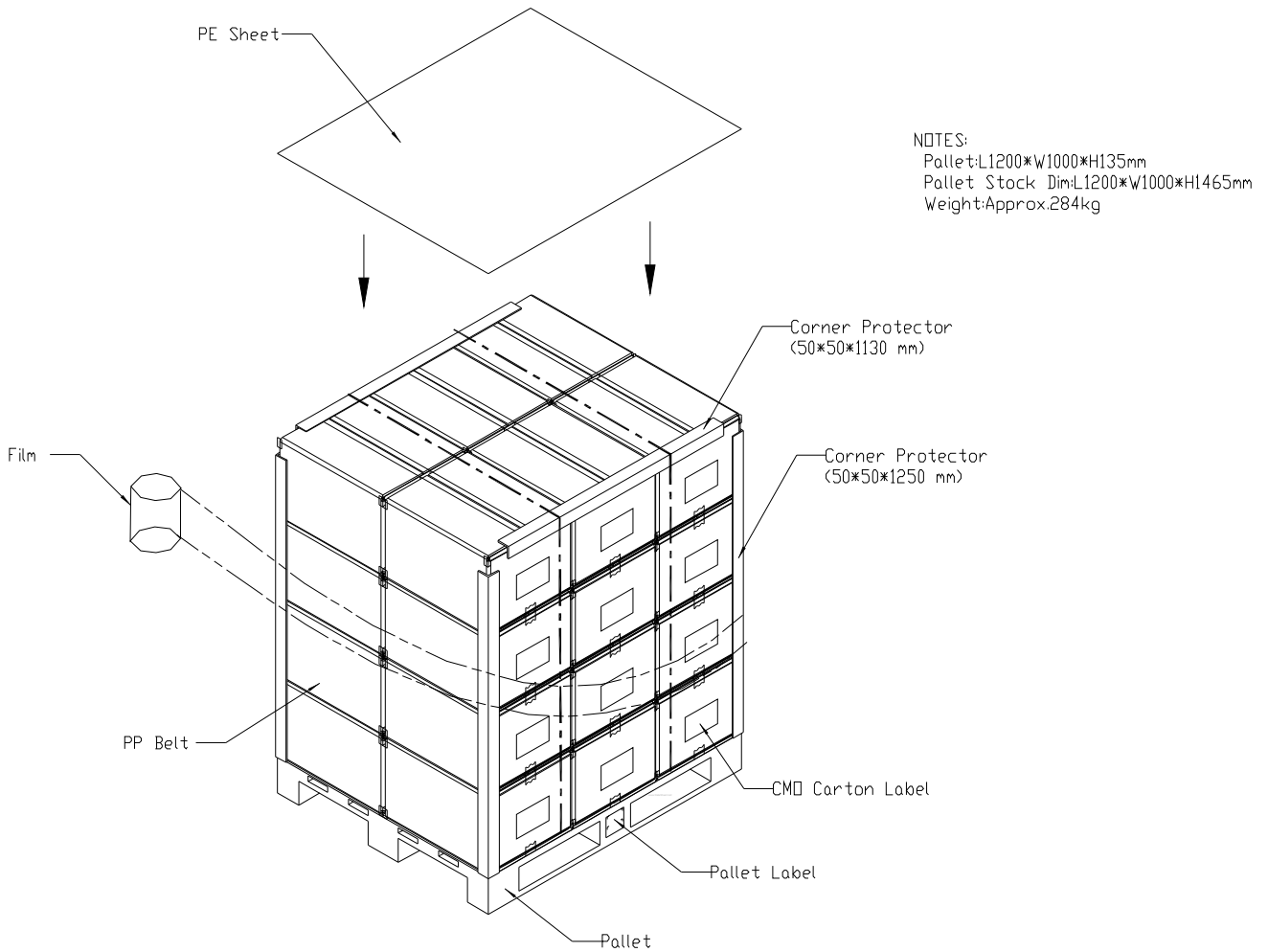
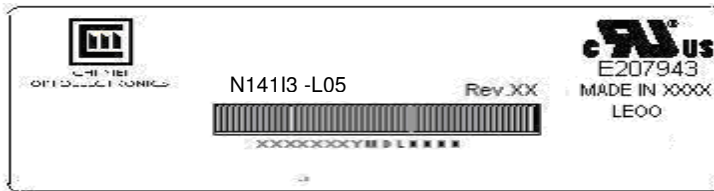

Figure. 10-3 Packing method

11 DEFINITION OF LABELS

11.1 CMO MODULE LABEL

The barcode nameplate is pasted on each module as illustration, and its definitions are as following explanation.



- (a) Model Name: N141I3 - L05
- (b) Revision: Rev. XX, for example: A1, ..., C1, C2 ...etc.
- (c) Serial ID: X X X X X X X Y M D X N N N N
 - Serial No.
 - CMO Internal Use
 - Year, Month, Date
 - CMO Internal Use
 - Revision
 - CMO Internal Use
- (d) Production Location: MADE IN XXXX. XXXX stands for production location.
- (e) UL/CB logo: "LEOO" especially stands for panel manufactured by CMO Ningbo satisfying UL/CB requirement. "LEOO" is the CMO's UL factory code for Ningbo factory.

Serial ID includes the information as below:

- (a) Manufactured Date: Year: 1~9, for 2001~2009
 Month: 1~9, A~C, for Jan. ~ Dec.
 Day: 1~9, A~Y, for 1st to 31st, exclude I , O and U
- (b) Revision Code: cover all the change
- (c) Serial No.: Manufacturing sequence of product

Dell PPID label contains information as below:



- (a) Serial ID: TW-0SSSSS-70896-YMD-XXXX
 - Serial Numbers
 - Production Year, Month, Date
 - Manufacturing ID
 - Part Number
- (b) Production location: Made in XXXX.
- (c) Revision code: X00, X10, X20, A00..etc.

11.2 CMO CARTON LABEL

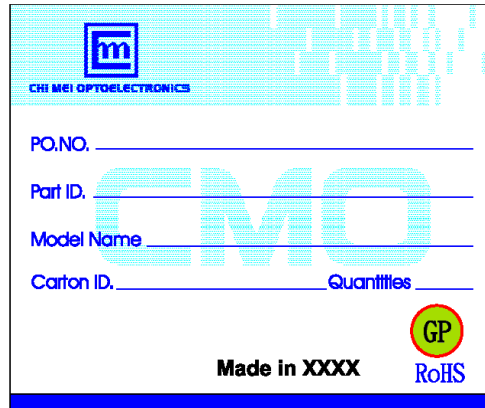

(a) Production location: Made In XXXX. XXXX stands for production location.

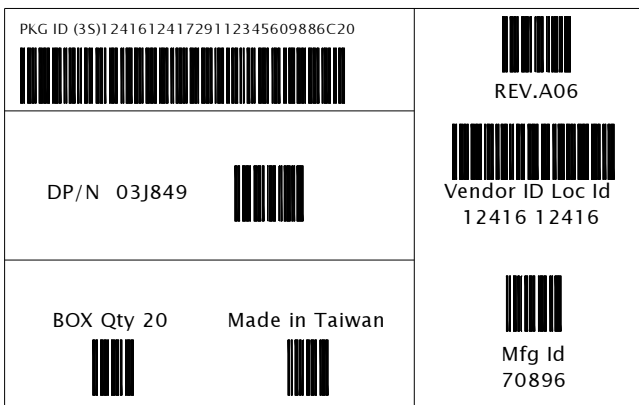

11.3 CARTON LABEL



Type J Label

- Verdana font or equivalent,bold
- 20pt.-all fields
- 203 DPI printer minimum
- Code 128B
- 10-15 mil minimum narrow bar
- .75"minimum barcode height
- .10" or greater quiet zone
- 4.0" x 6.0" label size
- Brady THT -25-402-1 or equivalent
- Brady R6107 series ribbon or equivalent

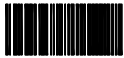
11.4 PALLET LABEL

FROM : CMO Corporation Tainan, Taiwan 744 R.O.C		TO: DELL COMPUTER 2128 West Braker Austin TX	
P.O. NUMBER 12345678			
		DELL P/N 12345	
COUNTRY OF ORIGIN TW			
		PACKING LIST# 1234567890123	
PACKING LIST QTY 654321			
		DESTINATION MAS LOC 60	
DESTINATION LOCATION B4			
AIRBILL NUMBER 12345678901234567890			
			
PKG CNT 999 OF 999	BOX CNT 12345	REVISION A00-00	SHIP DATE Apr 29,2003
PART DESCRIPTION XXXXXXXXXXXXXXXXXXXXXXXX 12345678901234567890123456789012345678901			

Type K Label

- Verdana font or equivalent, bold
- 12pt.-all descript fields
- 10pt.-all data fields
- 203 DPI printer minimum
- Code 128B
- 10 mil minimum narrow bar
- .30-.50" minimum barcode height
- .10" or greater quiet zone
- 4.0" x 6.5" label size
- Brady THT -78-402-.9 or equivalent
- Brady R6107 series ribbon or equivalent