

TFT LCD Approval Specification

MODEL NO.: N141I6

Suffix:-D11

Customer : _____

Approved by : _____

Note :

核准時間	部門	審核	角色	投票
2010-06-07 11:05:16	NB 產品管理處		Director	Accept

- CONTENTS -

REVISION HISTORY	-----	3
1. GENERAL DESCRIPTION	-----	4
1.1 OVERVIEW		
1.2 FEATURES		
1.3 APPLICATION		
1.4 GENERAL SPECIFICATIONS		
1.5 MECHANICAL SPECIFICATIONS		
2. ABSOLUTE MAXIMUM RATINGS	-----	5
2.1 ABSOLUTE RATINGS OF ENVIRONMENT		
2.2 ELECTRICAL ABSOLUTE RATINGS		
3. ELECTRICAL CHARACTERISTICS	-----	7
3.1 TFT LCD MODULE		
3.2 DISPLAY PORT INTERFACE		
3.3 BACKLIGHT UNIT		
4. BLOCK DIAGRAM	-----	11
4.1 TFT LCD MODULE		
5. INPUT TERMINAL PIN ASSIGNMENT	-----	12
5.1 TFT LCD MODULE		
5.2 COLOR DATA INPUT ASSIGNMENT		
5.3 EDID DATA STRUCTURE		
6. CONVERTER	-----	18
6.1 ABSOLUTE MAXIMUM RATINGS		
6.2 RECOMMENDED OPERATING RATINGS		
7. INTERFACE TIMING	-----	21
7.1 DISPLAY SIGNAL TIMING SPECIFICATIONS		
7.2 POWER ON/OFF SEQUENCE		
8. OPTICAL CHARACTERISTICS	-----	24
8.1 TEST CONDITIONS		
8.2 OPTICAL SPECIFICATIONS		
9. PRECAUTIONS	-----	28
9.1 HANDLING PRECAUTIONS		
9.2 STORAGE PRECAUTIONS		
9.3 OPERATION PRECAUTIONS		
10. SAFETY REVIEW	-----	29
10.1 SAFETY STANDARDS		
11. PACKING	-----	29
11.1 CARTON		
11.2 PALLET		
12. DEFINITION OF LABELS	-----	31
12.1 CMO MODULE LABEL		
12.2 DELL MODULE LABEL		
12.3 CMO CARTON LABEL		
12.4 DELL CARTON LABEL		

REVISION HISTORY

Version	Date	Page (New)	Section	Description
Ver 0.0	Mar. 11,'10	All	All	Tentative specification 0.0 was first issued for N141I6-D11.
Ver 1.0	Apr. 23,'10	All	All	Preliminary specification 1.0 was first issued for N141I6-D11.
Ver 2.0	Jun.01.'10	All	All	Approval specification 2.0 was first issued for N141I6-D11.

1. GENERAL DESCRIPTION

1.1 OVERVIEW

N141I6-D11 is a 14.1" TFT Liquid Crystal Display module with LED Backlight unit and 30-pin DisplayPort interface. This module supports 1280 x 800 WXGA mode and can display 262,144 colors. The optimum viewing angle is at 6 o'clock direction.

1.2 FEATURES

- WXGA (1280 x 800 pixels) resolution
- Display port interface
- White LED Backlight
- LED converter embedded

1.3 APPLICATION

- TFT LCD Notebook

1.4 GENERAL SPECIFICATIONS

Item	Specification	Unit	Note
Active Area	303.36 (H) x 189.6 (V) (14.1" diagonal)	mm	(1)
Bezel Opening Area	308.65 (H) x 193.35 (V)	mm	
Driver Element	a-si TFT active matrix	-	-
Pixel Number	1280 x R.G.B. x 800	pixel	-
Pixel Pitch	0.237 (H) x 0.237 (V)	mm	-
Pixel Arrangement	RGB vertical stripe	-	-
Display Colors	262,144	color	-
Transmissive Mode	Normally white	-	-
Surface Treatment	3H, Anti-glare type	-	-

1.5 MECHANICAL SPECIFICATIONS

Item	Min.	Typ.	Max.	Unit	Note	
Module Size	Horizontal(H)	319	319.5	320	mm	(1)
	Vertical(V)	206	206.5	207	mm	
	Thickness(T)	-	5.2	5.5	mm	
Weight	-	360	375	g	-	

Note (1) Please refer to the attached drawings for more information of front and back outline dimensions.

2. ABSOLUTE MAXIMUM RATINGS

2.1 ABSOLUTE RATINGS OF ENVIRONMENT

Item	Symbol	Value		Unit	Note
		Min.	Max.		
Storage Temperature	T_{ST}	-20	+60	°C	(1)
Operating Ambient Temperature	T_{OP}	0	+50	°C	(1), (2)
Shock (Non-Operating)	S_{NOP}	-	220/2	G/ms	(3), (5)
Vibration (Non-Operating)	V_{NOP}	-	1.5	G	(4), (5)

Note (1) (a) 90 %RH Max. ($T_a \leq 40$ °C).

(b) Wet-bulb temperature should be 39 °C Max. ($T_a > 40$ °C).

(c) No condensation.

Note (2) The temperature of panel surface should be 0 °C min. and 50 °C max.

Relative Humidity (%RH)

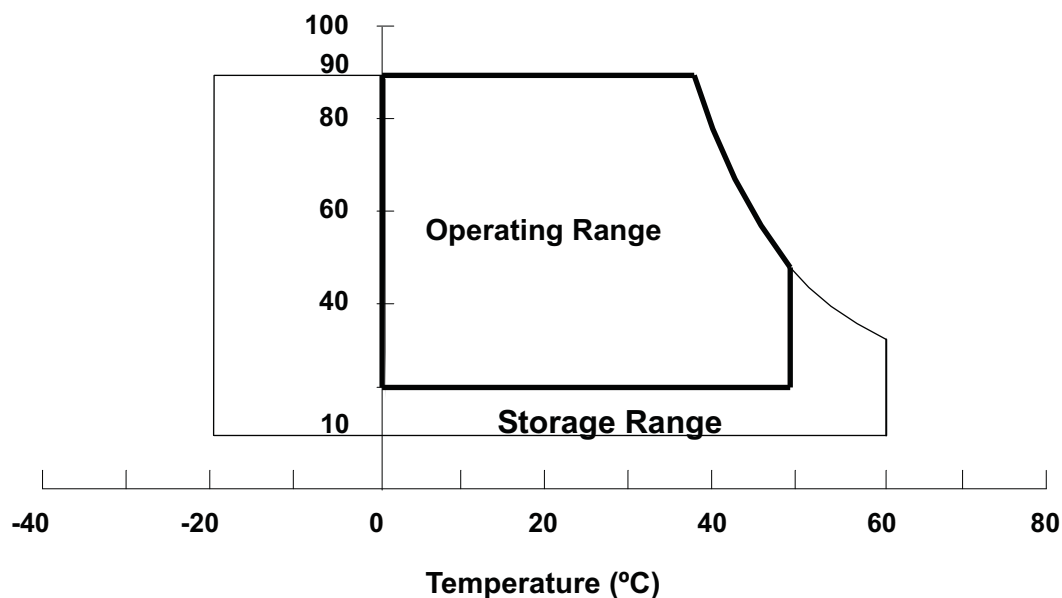

Note (3) 1 time for $\pm X$, $\pm Y$, $\pm Z$. for Condition (220G / 2ms) is half Sine Wave,.

Note (4) 10~500 Hz, 0.5hr/cycle 1cycle for X,Y,Z

Note (5) At testing Vibration and Shock, the fixture in holding the module has to be hard and rigid enough so that the module would not be twisted or bent by the fixture.

The fixing condition is shown as below:

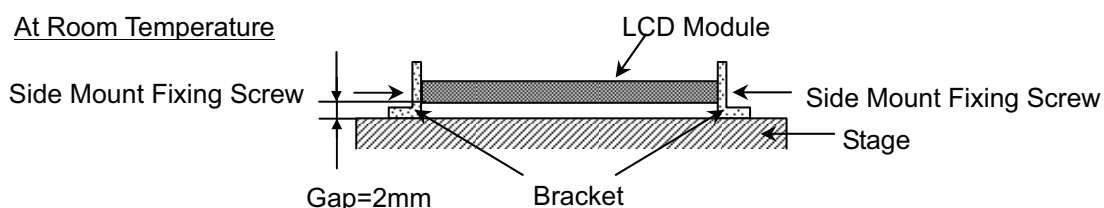

2.2 ELECTRICAL ABSOLUTE RATINGS

2.2.1 TFT LCD MODULE

Item	Symbol	Value		Unit	Note
		Min.	Max.		
Power Supply Voltage	V_{CC}	-0.3	+4.0	V	(1)
Logic Input Voltage	V_{IN}	-0.3	$V_{CC}+0.3$	V	

Note (1) Permanent damage to the device may occur if maximum values are exceeded. Function operation should be restricted to the conditions described under Normal Operating Conditions.

2.2.2 BACKLIGHT UNIT

Item	Symbol	Value		Unit	Note
		Min.	Max.		
LED Light Bar Power Supply Voltage	VL	-35	24.5	V	(1), (2)
LED Light Bar Power Supply Current	IL	0	150	mA	

Note (1) Permanent damage to the device may occur if maximum values are exceeded. Function operation should be restricted to the conditions described under Normal Operating Conditions.

Note (2) Specified values are for LED (Refer to Section 3.3 for further information)

3. ELECTRICAL CHARACTERISTICS

3.1 TFT LCD MODULE

Ta = 25 ± 2 °C

Parameter	Symbol	Value			Unit	Note
		Min.	Typ.	Max.		
Power Supply Voltage	VCCS	3.0	3.3	3.6	V	-
Permissible Ripple Voltage	V _{RP}	-	50	-	mV	-
Rush Current	I _{RUSH}	-	-	1.5	A	(2)
Initial Stage Current	I _{IS}	-	-	1.0	A	(2)
Power Supply Current	White	-	190	230	mA	(3)a
	Black	-	310	360	mA	(3)b
Power per EBL WG	P _{EBL}	-	1.5	-	W	(4)

Note (1) The ambient temperature is Ta = 25 ± 2 °C.

Note (2) I_{RUSH}: the maximum current when VCCS is risingI_{IS}: the maximum current of the first 100ms after power-on

Measurement Conditions: Shown as the following figure. Test pattern: black.

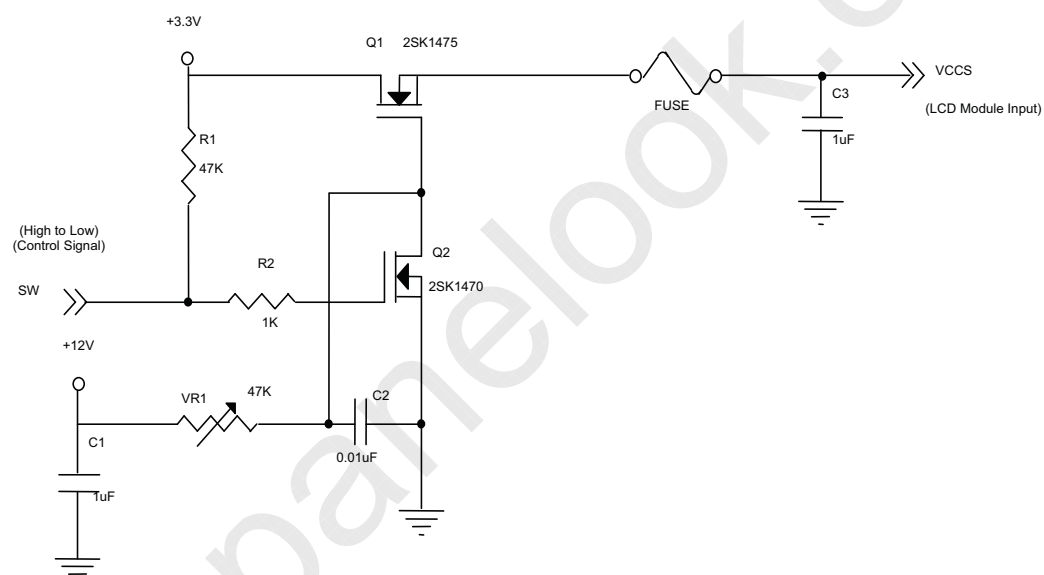

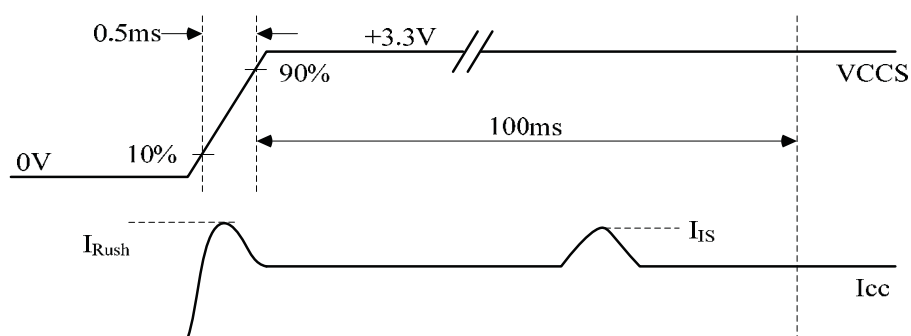
VCCS rising time is 0.5ms

Note (3) The specified power supply current is under the conditions at $VCCS = 3.3\text{ V}$, $T_a = 25 \pm 2\text{ }^\circ\text{C}$, DC Current and $f_v = 60\text{ Hz}$, whereas a power dissipation check pattern below is displayed.

a. White Pattern



Active Area

b. Black Pattern



Active Area

Note (4) The specified power are the sum of LCD panel electronics input power and the converter input power. Test conditions are as follows.

(a) $VCCS = 3.3\text{ V}$, $T_a = 25 \pm 2\text{ }^\circ\text{C}$, $f_v = 60\text{ Hz}$,

(b) The pattern used is a black and white 32 x 36 checkerboard, slide #100 from the VESA file "Flat Panel Display Monitor Setup Patterns", FPDMSU.ppt.

(c) Luminance: 60 nits.

3.2 DISPLAY PORT INTERFACE

Parameter	Symbol	Min.	Typ.	Max.	Unit	Notes
MainLink Input Signal Peak-to-peak Voltage	$ VDIFF_{P-P} _{(MainLink)}$	120	-	-	mV	High bit rate
		40	-	-	mV	Reduced bit rate
AUX Differential Input Voltage	$ V_{ID} _{(AUX)}$	160	-	680	mV	
Differential Signal Common Mode Voltage	VCM	0		2	V	
AUX AC Coupling Capacitor	C_{AUX}	75		200	nF	
Lane Intra-pair Skew	$V_{RX-SKEW-INTRA_PAIR}$	-	-	100	ps	High bit rate
		-	-	300		Reduced bit rate

Note (1) Display port interface related AC coupled signals are following VESA Display Port Standard V1.1a

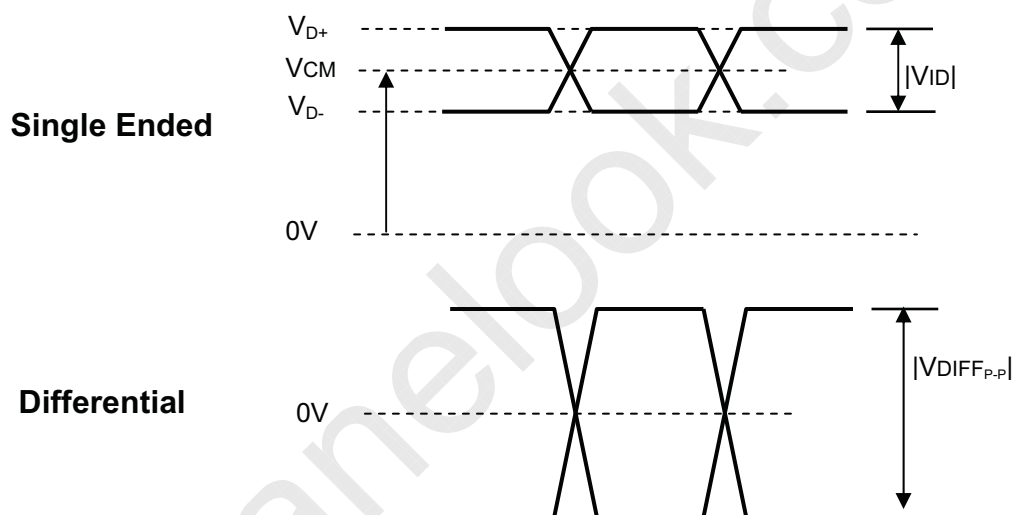

3.3 BACKLIGHT UNIT

Ta = 22 ± 2 °C

Parameter	Symbol	Value				Notes
		Min.	Typ.	Max.		
LED Quantity			42		Pcs	(1)
LED Light Bar Power Supply Voltage	VL	19.6	21.7	23.8	V	(1),(2)
LED Light Bar Power Supply Current	IL	102.6	108	113.4	mA	
Power Consumption	PL	2.01	2.34	2.69	W	(3), Duty=100%
LED Life Time	LBL	12000	-	-	Hrs	(4)

Note (1) LED light bar configuration is shown as below.

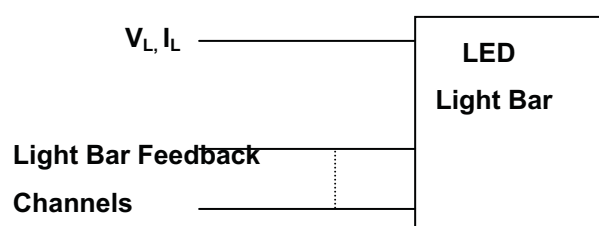

Note (2) For better LED light bar driving quality, it is recommended to utilize the adaptive boost converter with current balancing function to drive LED light-bar.

Note (3) $P_L = I_L \times V_L$

Note (4) LED Lifetime was defined as the time when it continues to operate under the conditions at $T_a = 25 \pm 2 \text{ }^\circ\text{C}$ and $I_L = 18 \text{ mA}$ (Per EA) until the brightness becomes $\leq 50\%$ of its original value.

4. BLOCK DIAGRAM

4.1 TFT LCD MODULE

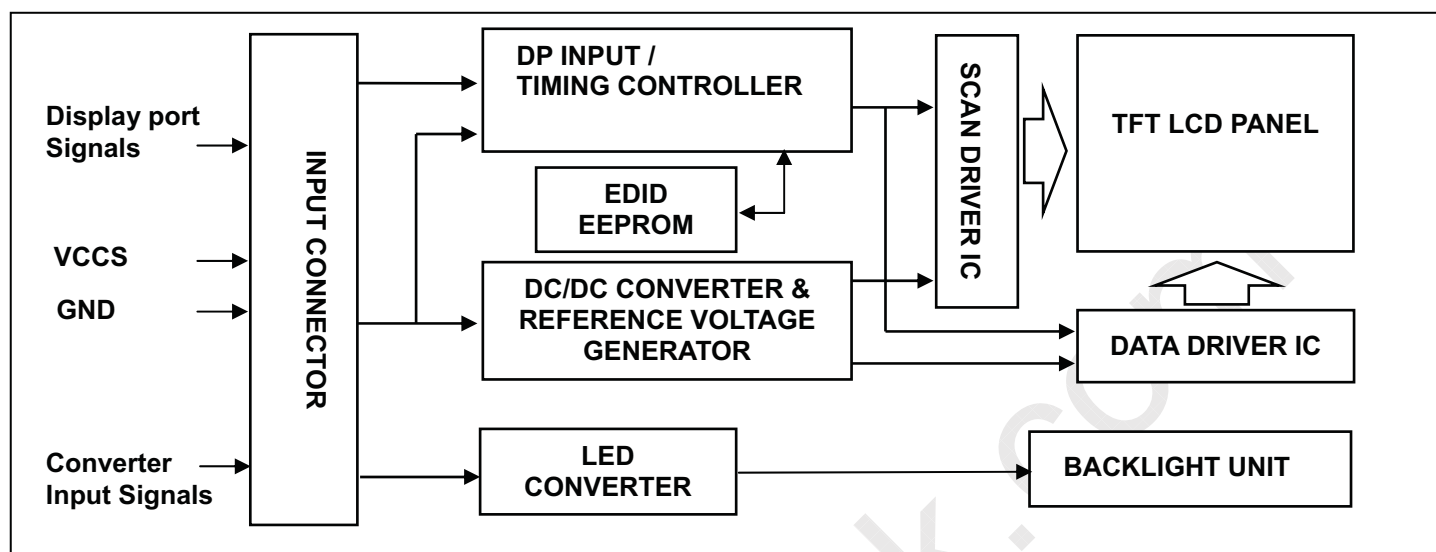

5. INPUT TERMINAL PIN ASSIGNMENT**5.1 TFT LCD MODULE**

Pin	Symbol	Description	Remark
1	PAID	Conn. Continuity Test	
2	NC	No Connection (Reserved)	
3	NC	No Connection (Reserved)	
4	NC	No Connection (Reserved)	
5	H_GND	High Speed Ground	
6	ML0-	Complement Signal-Lane 0	
7	ML0+	True Signal-Main Lane 0	
8	H_GND	High Speed Ground	
9	AUX+	True Signal-Auxiliary Channel	
10	AUX-	Complement Signal-Auxiliary Channel	
11	H_GND	High Speed Ground	
12	VCCS	Power Supply +3.3 V (typical)	
13	VCCS	Power Supply +3.3 V (typical)	
14	BIST	Built-In Self Test (active high)	
15	GND	Ground	
16	GND	Ground	
17	HPD	Hot Plug Detect	
18	BL_GND	BL Ground	
19	BL_GND	BL Ground	
20	BL_GND	BL Ground	
21	BL_GND	BL Ground	
22	NC	(CMO Reserved)	
23	LED_PWM	PWM Dimming Control Signal of LED Converter	
24	SMBUS_CLK	Backlight Control CLK	
25	SMBUS_DATA	Backlight Control Data	
26	LED_VCCS	BL Power	(Support 7.5 ~ 21V)
27	LED_VCCS	BL Power	(Support 7.5 ~ 21V)
28	LED_VCCS	BL Power	(Support 7.5 ~ 21V)
29	LED_VCCS	BL Power	(Support 7.5 ~ 21V)
30	PAID	Conn. Continuity Test	

Note (1) Connector Part No.: I-PEX 20455-030E-12 or equivalent

Note (2) User's connector Part No.: I-PEX 20453-030T-11 or equivalent

Note (3) The first pixel is odd as shown in the following figure.

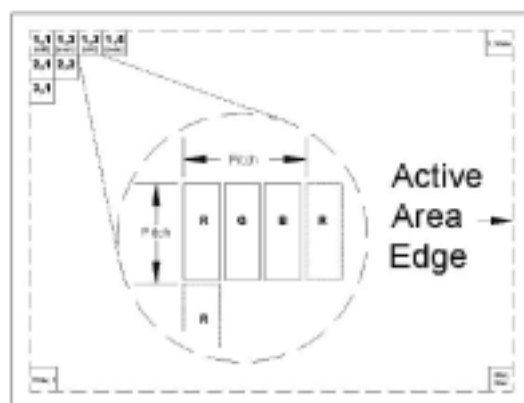

5.2 COLOR DATA INPUT ASSIGNMENT

The brightness of each primary color (red, green and blue) is based on the 6-bit gray scale data input for the color. The higher the binary input the brighter the color. The table below provides the assignment of color versus data input.

Color		Data Signal																	
		Red						Green						Blue					
		R5	R4	R3	R2	R1	R0	G5	G4	G3	G2	G1	G0	B5	B4	B3	B2	B1	B0
Basic Colors	Black	0	0	0	0	0	0	0	0	0	0	0	0	0	0	0	0	0	0
	Red	1	1	1	1	1	1	0	0	0	0	0	0	0	0	0	0	0	0
	Green	0	0	0	0	0	0	1	1	1	1	1	1	0	0	0	0	0	0
	Blue	0	0	0	0	0	0	0	0	0	0	0	0	1	1	1	1	1	1
	Cyan	0	0	0	0	0	0	1	1	1	1	1	1	1	1	1	1	1	1
	Magenta	1	1	1	1	1	1	0	0	0	0	0	0	1	1	1	1	1	1
	Yellow	1	1	1	1	1	1	1	1	1	1	1	1	0	0	0	0	0	0
	White	1	1	1	1	1	1	1	1	1	1	1	1	1	1	1	1	1	1
Gray Scale Of Red	Red(0)/Dark	0	0	0	0	0	0	0	0	0	0	0	0	0	0	0	0	0	0
	Red(1)	0	0	0	0	0	1	0	0	0	0	0	0	0	0	0	0	0	0
	Red(2)	0	0	0	0	1	0	0	0	0	0	0	0	0	0	0	0	0	0
	:	:	:	:	:	:	:	:	:	:	:	:	:	:	:	:	:	:	:
	:	:	:	:	:	:	:	:	:	:	:	:	:	:	:	:	:	:	:
	Red(61)	1	1	1	1	0	1	0	0	0	0	0	0	0	0	0	0	0	0
	Red(62)	1	1	1	1	1	0	0	0	0	0	0	0	0	0	0	0	0	0
Red(63)	1	1	1	1	1	1	0	0	0	0	0	0	0	0	0	0	0	0	
Gray Scale Of Green	Green(0)/Dark	0	0	0	0	0	0	0	0	0	0	0	0	0	0	0	0	0	0
	Green(1)	0	0	0	0	0	0	0	0	0	0	1	0	0	0	0	0	0	0
	Green(2)	0	0	0	0	0	0	0	0	0	0	1	0	0	0	0	0	0	0
	:	:	:	:	:	:	:	:	:	:	:	:	:	:	:	:	:	:	:
	:	:	:	:	:	:	:	:	:	:	:	:	:	:	:	:	:	:	:
	Green(61)	0	0	0	0	0	0	1	1	1	1	0	1	0	0	0	0	0	0
	Green(62)	0	0	0	0	0	0	1	1	1	1	1	0	0	0	0	0	0	0
Green(63)	0	0	0	0	0	0	1	1	1	1	1	1	0	0	0	0	0	0	
Gray Scale Of Blue	Blue(0)/Dark	0	0	0	0	0	0	0	0	0	0	0	0	0	0	0	0	0	0
	Blue(1)	0	0	0	0	0	0	0	0	0	0	0	0	0	0	0	0	0	1
	Blue(2)	0	0	0	0	0	0	0	0	0	0	0	0	0	0	0	0	1	0
	:	:	:	:	:	:	:	:	:	:	:	:	:	:	:	:	:	:	:
	:	:	:	:	:	:	:	:	:	:	:	:	:	:	:	:	:	:	:
	Blue(61)	0	0	0	0	0	0	0	0	0	0	0	0	1	1	1	1	0	1
	Blue(62)	0	0	0	0	0	0	0	0	0	0	0	0	1	1	1	1	1	0
Blue(63)	0	0	0	0	0	0	0	0	0	0	0	0	1	1	1	1	1	1	

Note (1) 0: Low Level Voltage, 1: High Level Voltage

5.3 EDID DATA STRUCTURE

The EDID (Extended Display Identification Data) data formats are to support displays as defined in the VESA Plug & Display and FPD1 standards.

Byte # (decimal)	Byte # (hex)	Field Name and Comments	Value (hex)	Value (binary)
0	0	Header , Fixed	00	00000000
1	1	Header , Fixed	FF	11111111
2	2	Header , Fixed	FF	11111111
3	3	Header , Fixed	FF	11111111
4	4	Header , Fixed	FF	11111111
5	5	Header , Fixed	FF	11111111
6	6	Header , Fixed	FF	11111111
7	7	Header , Fixed	00	00000000
8	8	ID system manufacturer name	0D	00001101
9	9	ID system manufacturer name	AF	10101111
10	0A	ID system Product Code (LSB)	62	01100010
11	0B	ID system Product Code (MSB)	14	00010100
12	0C	32-bit serial # Unused(01h for VESA, 00h for SPWG)	00	00000000
13	0D	32-bit serial # Unused(01h for VESA, 00h for SPWG)	00	00000000
14	0E	32-bit serial # Unused(01h for VESA, 00h for SPWG)	00	00000000
15	0F	32-bit serial # Unused(01h for VESA, 00h for SPWG)	00	00000000
16	10	Week of manufacture 1 - 53 (unused: 00h) : 10h fixed by CMO	12	00010010
17	11	Year of manufacture year - 1990(unsed:00h) : 13h (Year 2009) fixed by CMO	14	00010100
18	12	Version=1	01	00000001
19	13	Revision=4	04	00000100
20	14	Digital	95	10010101
21	15	Active area horizontal 303.36cm	1E	00011110
22	16	Active area vertical 189.6cm	13	00010011
23	17	Display Gamma (Gamma = "2.2")	78	01111000
24	18	Feature support ("Active off, RGB Color")	02	00000010
25	19	Rx1, Rx0, Ry1, Ry0, Gx1, Gx0, Gy1, Gy0	87	10000111
26	1A	Bx1, Bx0, By1, By0, Wx1, Wx0, Wy1, Wy0	F5	11110101
27	1B	Rx=0.58	94	10010100
28	1C	Ry=0.34	57	01010111
29	1D	Gx=0.31	4F	01001111
30	1E	Gy=0.55	8C	10001100
31	1F	Bx=0.155	27	00100111
32	20	By=0.155	27	00100111
33	21	Wx=0.313	50	01010000
34	22	Wy=0.329	54	01010100
35	23	Established timings 1	00	00000000
36	24	Established timings 2 (1280x800@60Hz)	00	00000000
37	25	No manufacturer's specific timing	00	00000000
38	26	Standard timing ID # 1	01	00000001
39	27	Standard timing ID # 1	01	00000001

Approval

Byte # (decimal)	Byte # (hex)	Field Name and Comments	Value (hex)	Value (binary)
40	28	Standard timing ID # 2	01	00000001
41	29	Standard timing ID # 2	01	00000001
42	2A	Standard timing ID # 3	01	00000001
43	2B	Standard timing ID # 3	01	00000001
44	2C	Standard timing ID # 4	01	00000001
45	2D	Standard timing ID # 4	01	00000001
46	2E	Standard timing ID # 5	01	00000001
47	2F	Standard timing ID # 5	01	00000001
48	30	Standard timing ID # 6	01	00000001
49	31	Standard timing ID # 6	01	00000001
50	32	Standard timing ID # 7	01	00000001
51	33	Standard timing ID # 7	01	00000001
52	34	Standard timing ID # 8	01	00000001
53	35	Standard timing ID # 8	01	00000001
54	36	Detailed timing description # 1 Pixel clock ("68.84MHz", According to VESA CVT Rev1.1)	E4	11100100
55	37	68.84MHz/10000 =6884=1AE4(Hex)	1A	00011010
56	38	HActive(D7-D0) = 1280 mod 256	00	00000000
57	39	HBlank(D7-D0) = 114 mod 256	72	01110010
58	3A	HActive(D11-D8) : HBlank(D11-D8) = 1280/256 : 114/256	50	01010000
59	3B	VActive(D7-D0) =800 mod 256	20	00100000
60	3C	VBlank(D7-D0) = 23 mod 256	17	00010111
61	3D	VActive(D11-D8) : VBlank(D11-D8) = 800/256 : 23/256	30	00110000
62	3E	HSyncOffset(D7-D0) = HBorder+HFrontPorch = 48	30	00110000
63	3F	HSyncWidth(D7-D0) = 32	20	00100000
64	40	VSyncoffset(D3-D0)=3 : VSyncoffset(D3-D0)=6	36	00110110
65	41	HSyncOffset(D9-D8) : HSyncWidth(D9-D8) : VSyncoffset(D5-D4) : VSyncoffset(D5-D4)	00	00000000
66	42	HImageSize(mm, D7-D0) = 303mod 256	2F	00101111
67	43	VImageSize(mm, D7-D0) = 189mod 256	BD	10111101
68	44	HImageSize(D11-D8) : VImageSize(D11-D8) = 303/256 : 189/256	10	00010000
69	45	Horizontal Border=0	00	00000000
70	46	Vertical Border=0	00	00000000
71	47	Non-interlaced, Normal Display, Digital separate, Positive Hsync, Negative Vsync	1A	00011010
72	48	Detailed timing description # 1 Pixel clock ("45.89MHz", According to VESA CVT Rev1.1)	ED	11101101
73	49	45.89MHz/10000 =4589=11ED(Hex)	11	00010001
74	4A	HActive(D7-D0) = 1280 mod 256	00	00000000
75	4B	HBlank(D7-D0) = 114 mod 256	72	01110010
76	4C	HActive(D11-D8) : HBlank(D11-D8) = 1280/256 : 114/256	50	01010000
77	4D	VActive(D7-D0) =800 mod 256	20	00100000
78	4E	VBlank(D7-D0) = 23 mod 256	17	00010111
79	4F	VActive(D11-D8) : VBlank(D11-D8) = 800/256 : 23/256	30	00110000
80	50	HSyncOffset(D7-D0) = HBorder+HFrontPorch = 48	30	00110000
81	51	HSyncWidth(D7-D0) = 32	20	00100000

Approval

Byte # (decimal)	Byte # (hex)	Field Name and Comments	Value (hex)	Value (binary)
82	52	VSyncOffset(D3-D0)=3 : VSyncWidth(D3-D0)=6	36	00110110
83	53	HSyncOffset(D9-D8) : HSyncWidth(D9-D8) : VSyncOffset(D5-D4) : VSyncWidth(D5-D4)	00	00000000
84	54	HImageSize(mm, D7-D0) = 303mod 256	2F	00101111
85	55	VImageSize(mm, D7-D0) = 189mod 256	BD	10111101
86	56	HImageSize(D11-D8) : VImageSize(D11-D8) = 303/256 : 189/256	10	00010000
87	57	Horizontal Border=0	00	00000000
88	58	Vertical Border=0	00	00000000
89	59	Non-interlaced, Normal Display, Digital separate, Positive Hsync, Negative Vsync	1A	00011010
90	5A	Flag	00	00000000
91	5B	Flag	00	00000000
92	5C	Flag	00	00000000
93	5D	Data Type Tag: Alphanumeric Data String (ASCII)	FE	11111110
94	5E	Flag	00	00000000
95	5F	Dell P/N 1st Character "J"	4A	01001010
96	60	Dell P/N 2nd Character "X"	58	01011000
97	61	Dell P/N 3rd Character "C"	43	01000011
98	62	Dell P/N 4th Character "N"	4E	01001110
99	63	Dell P/N 5th Character "8"	38	00111000
100	64	EDID Revision	80	00000000
101	65	Manufacturer P/N "N"	4E	01001110
102	66	Manufacturer P/N "1"	31	00110001
103	67	Manufacturer P/N "4"	34	00110100
104	68	Manufacturer P/N "1"	31	00110001
105	69	Manufacturer P/N "I"	49	01001001
106	6A	Manufacturer P/N "6"	36	00110110
107	6B	Manufacturer P/N (If <13 char, then terminate with ASCII code 0Ah, set remaining char = 20h)	0A	00001010
108	6C	Flag	00	00000000
109	6D	Flag	00	00000000
110	6E	Flag	00	00000000
111	6F	Data Type Tag: Manufacturer Specified Data 00	00	00000000
112	70	Flag	00	00000000
113	71	Color Management (defined below)	00	00000000
114	72	Panel Type and Revision (defined below)	41	01000001
115	73	Frame Rate (defined below)	31	00110001
116	74	Light Controller Interface and Maximum Typical Luminance (defined below)	16	00010110
117	75	Outdoor Features and Polarizer (defined below)	00	00000000
118	76	Multi-Media Features (defined below)	00	00000000
119	77	Multi-Media Features (defined below)	00	00000000
120	78	Special Features (defined below)	00	00000000
121	79	Special Feature (defined below)	09	00001001
122	7A	Special Features (defined below)	01	00000001

Approval

Byte # (decimal)	Byte # (hex)	Field Name and Comments	Value (hex)	Value (binary)
123	7B	(If <13 char, then terminate with ASCII code 0Ah, set remaining char = 20h)	0A	00001010
124	7C	(If <13 char, then terminate with ASCII code 0Ah, set remaining char = 20h)	20	00100000
125	7D	(If <13 char, then terminate with ASCII code 0Ah, set remaining char = 20h)	20	00100000
126	7E	No extension	00	00000000
127	7F	Checksum	6D	11101101

6. CONVERTER

6.1 ABSOLUTE MAXIMUM RATING

Symbol	Ratings
LED_VCCS	-0.3V~25V
LED_PWM	-0.3V~5.5V
SMBUS_CLK	-0.3V~5.5V
SMBUS_DATA	-0.3V~5.5V

6.2 RECOMMENDED OPERATING RATINGS

Parameter	Symbol	Value			Unit	Note
		Min.	Typ.	Max.		
Converter Input power supply voltage	LED_VCCS	7.5	12.0	21.0	V	-
Converter Rush Current	I _{LED_RUSH}	-	-	1.5	A	(1)
Converter Initial Stage Current	I _{LED_IS}	-	-	1.5	A	(1)
PWM Control Level	PWM High Level	2.3	-	5.5	V	-
	PWM Low Level	0	-	0.5	V	-
PWM Control Duty Ratio		10	-	100	%	-
		5	-	100	%	(2)
PWM Control Permissive Ripple Voltage	V _{PWM_pp}	-	-	100	mV	-
PWM Control Frequency	f _{PWM}	190	-	2K	Hz	(3)
LED Power Current	LED_VCCS =Min.	329	419	497	mA	(4)
	LED_VCCS =Typ.	206	262	310	mA	(4)
	LED_VCCS =Max.	117	150	177	mA	(4)
SM_Bus Interface	SM_Bus High Level	2.1	-	5.5	V	
	SM_Bus Low Level	0	-	0.8	V	
	Operatiing Frequency	10	-	100	kHz	
	Data Hold Time	T _{HD:DAT}	300	-	-	ns

Note (1) I_{LED_RUSH}: the maximum current when LED_VCCS is rising,

I_{LED_IS}: the maximum current of the first 100ms after power-on,

Measurement Conditions: Shown as the following figure. LED_VCCS = Typ, Ta = 25 ± 2 °C, f_{PWM} = 200 Hz, Duty=100%.

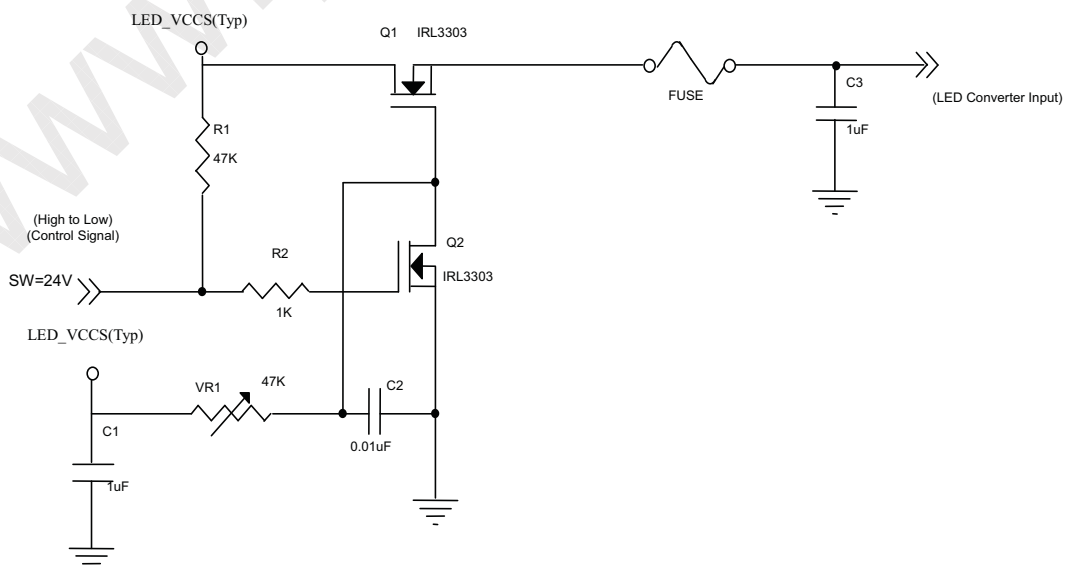

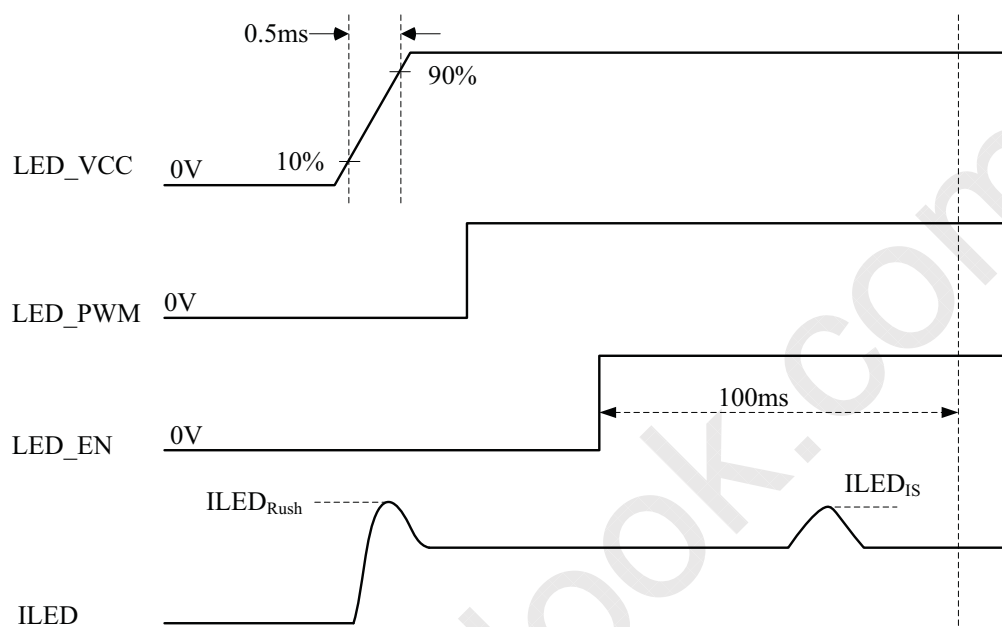
VLED rising time is 0.5ms

Note (2) If the PWM control duty ratio is less than 10%, there is some possibility that acoustic noise or backlight flash can be found. And it is also difficult to control the brightness linearity.

Note (3) If PWM control frequency is applied in the range less than 1KHz, the “waterfall” phenomenon on the screen may be found. To avoid the issue, it’s a suggestion that PWM control frequency should follow the criterion as below.

PWM control frequency f_{PWM} should be in the range

$$(N + 0.33) * f \leq f_{PWM} \leq (N + 0.66) * f$$

N : Integer ($N \geq 3$)

f : Frame rate

Note (4) The specified LED power supply current is under the conditions at “LED_VCCS = Min., Typ., Max.”,
 $T_a = 25 \pm 2 \text{ }^\circ\text{C}$, $f_{PWM} = 200 \text{ Hz}$, Duty=100%.

Note (5) SMBUS Interface

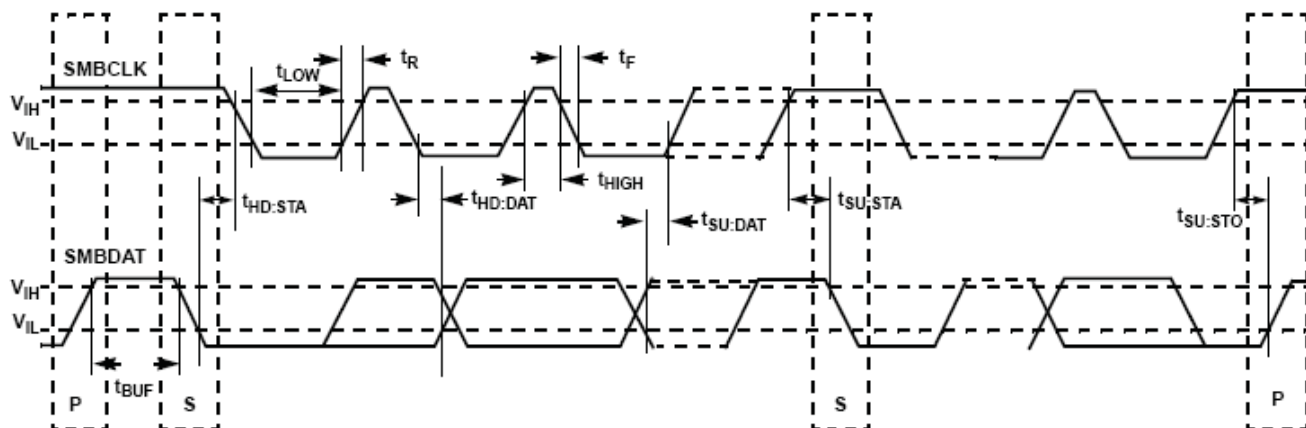

NOTES:

SMBus Description

S = start condition

P = stop condition

A = acknowledge

 \bar{A} = not acknowledgeR/ \bar{W} = read enable at high; write enable at low

7. INTERFACE TIMING

7.1 DISPLAY SIGNAL TIMING SPECIFICATIONS

The display signal timing specifications are shown as the following table and timing diagram.

Signal	Item	Symbol	Min.	Typ.	Max.	Unit	Note
DCLK	Frequency	1/Tc	-	68.84	-	MHz	-
DE	Vertical Total Time	TV	-	823	-	TH	-
	Vertical Active Display Period	TVD	800	800	800	TH	-
	Vertical Active Blanking Period	TVB	TV-TVD	23	TV-TVD	TH	-
	Horizontal Total Time	TH	-	1394	-	Tc	-
	Horizontal Active Display Period	THD	1280	1280	1280	Tc	-
	Horizontal Active Blanking Period	THB	TH-THD	114	TH-THD	Tc	-

Note (1) Display timing signal should be contained and transferred by Display Port Main Link stream data packing described in VESA Display Port Standard V1.1a

DISPLAY SIGNAL TIMING DIAGRAM

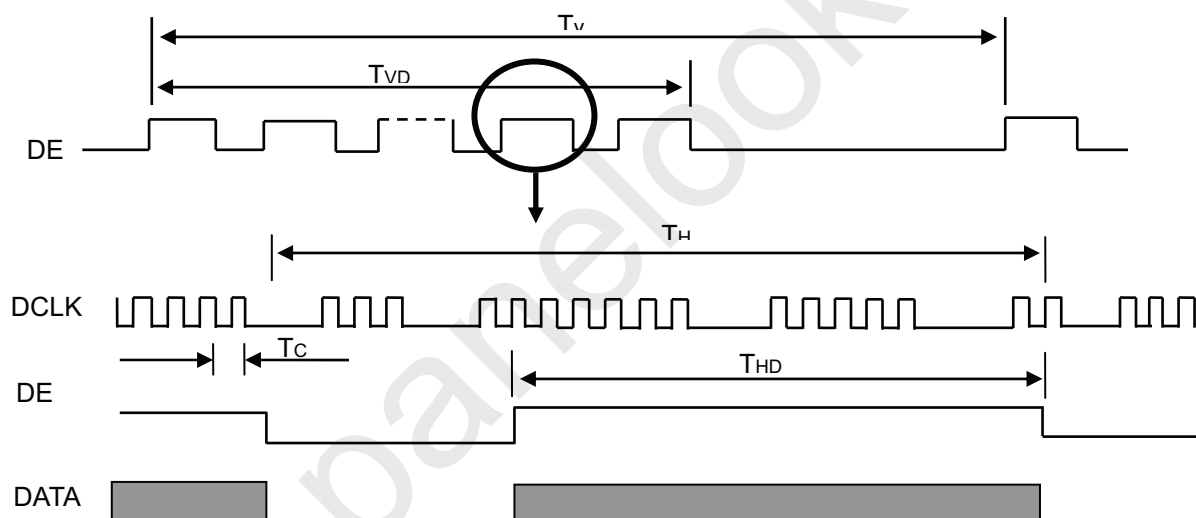

7.2 POWER ON/OFF SEQUENCE

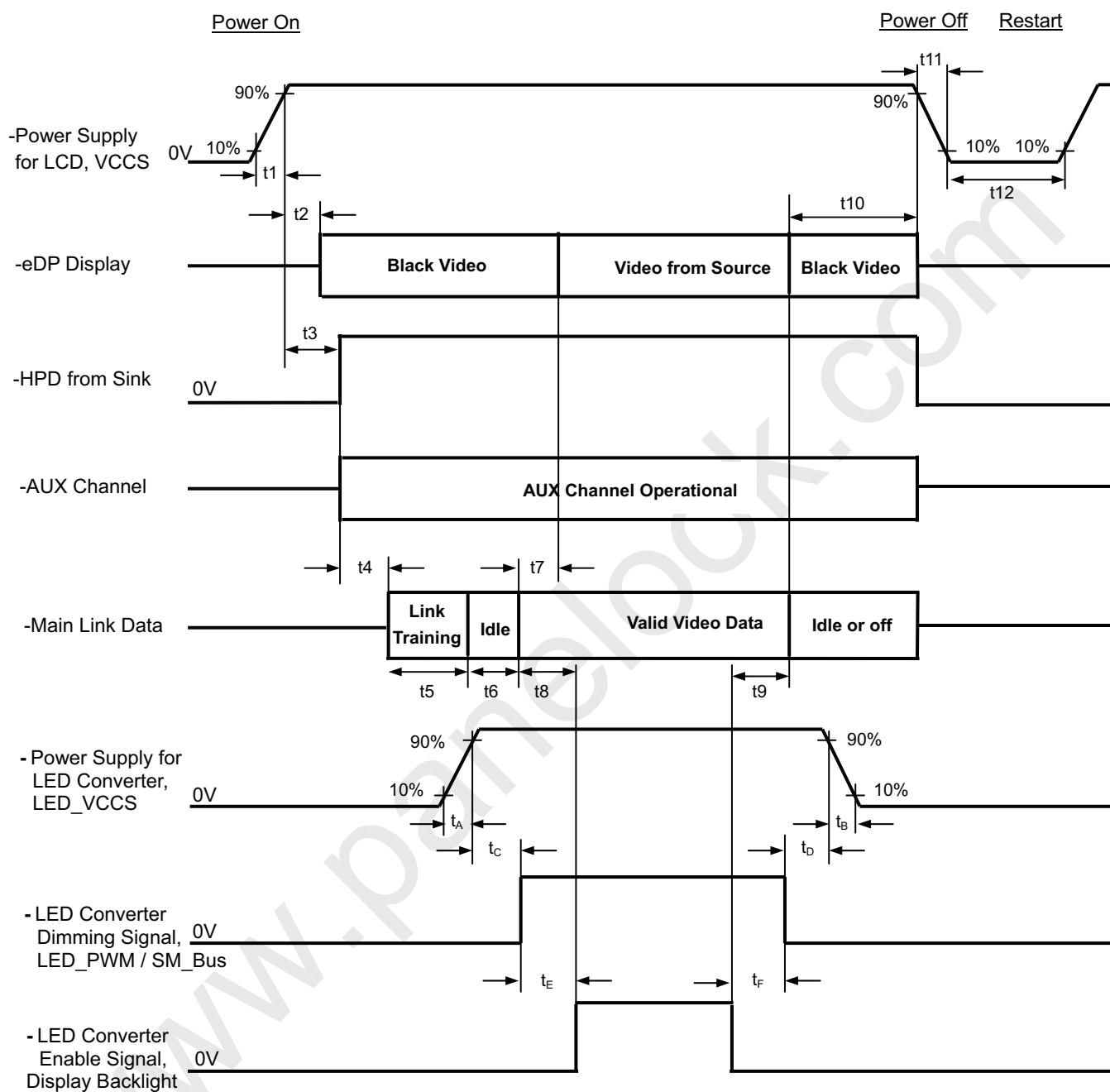

Timing Specifications: Follow VESA Embedded Display Port Standard Version 1

Parameter	Description	Reqd. By	Value		Unit	Notes
			Min	Max		
t1	Power rail rise time, 10% to 90%	Source	0.5	10	ms	-
t2	Delay from LCD,VCCS to black video generation	Sink	0	200	ms	-
t3	Delay from LCD,VCCS to HPD high	Sink	0	200	ms	-
t4	Delay from HPD high to link training initialization	Source	-	-	ms	-
t5	Link training duration	Source	-	-	ms	-
t6	Link idle	Source	-	-	ms	-
t7	Delay from valid video data from Source to video on display	Sink	0	50	ms	-
t8	Delay from valid video data from Source to backlight on	Source	-	-	ms	-
t9	Delay from backlight off to end of valid video data	Source	-	-	ms	-
t10	Delay from end of valid video data from Source to power off	Source	0	500	ms	-
t11	VCCS power rail fall time, 90% to 10%	Source	0.5	10	ms	-
t12	VCCS Power off time	Source	500	-	ms	-
t _A	LED power rail rise time, 10% to 90%	Source	0.5	10	ms	-
t _B	LED power rail fall time, 90% to 10%	Source	0	10	ms	-
t _C	Delay from LED power rising to LED dimming signal	Source	10	-	ms	-
t _D	Delay from LED dimming signal to LED power falling	Source	10	-	ms	-
t _E	Delay from LED dimming signal to LED enable signal	Source	10	-	ms	-
t _F	Delay from LED enable signal to LED dimming signal	Source	10	-	ms	-

Note (1) Please follow the power on/off sequence described above. Otherwise, the LCD module might abnormal display or be damaged.

Note (2) Please avoid floating state of interface signal at invalid period. When the interface signal is invalid, be sure to pull down the power supply of LCD VCCS to 0 V.

Note (3) The backlight must be turned on after the power supply for the logic and the interface signal is valid. The backlight must be turned off before the power supply for the logic and the interface signal is invalid.

Note (4) Please follow the LED backlight power sequence as above. If the customer could not follow, it might cause backlight flash issue during display ON/OFF or damage the LED backlight controller

8. OPTICAL CHARACTERISTICS

8.1 TEST CONDITIONS

Item	Symbol	Value	Unit
Ambient Temperature	Ta	22±2	°C
Ambient Humidity	Ha	50±10	%RH
Supply Voltage	Vcc	3.3	V
Input Signal	According to typical value in "3. ELECTRICAL CHARACTERISTICS"		
Converter Current	I _L	108	mA

The measurement methods of optical characteristics are shown in Section 8.2. The following items should be measured under the test conditions described in Section 8.1 and stable environment shown in Note (5).

8.2 OPTICAL SPECIFICATIONS

Item		Symbol	Condition	Min.	Typ.	Max.	Unit	Note
Contrast Ratio		CR	$\theta_x=0^\circ, \theta_y=0^\circ$ Viewing Normal Angle	300	500	-	-	(2), (5), (7)
Response Time		T _R		-	4	8	ms	(3), (7)
		T _F		-	12	17	ms	
Average Luminance of White		L _{AVE}		200	220		cd/m ²	(4), (6), (7)
Color Chromaticity	Red	R _x		TYP. -0.03	TYP. +0.03	0.580	-	(1), (7)
		R _y				0.340	-	
	Green	G _x				0.310	-	
		G _y				0.550	-	
	Blue	B _x				0.155	-	
		B _y				0.155	-	
	White	W _x	0.313			-		
		W _y	0.329			-		
Viewing Angle	Horizontal	θ_{x+}	40	45	-	Deg.	(1), (5), (7)	
		θ_{x-}	40	45	-			
	Vertical	θ_{y+}	15	20	-			
		θ_{y-}	40	45	-			
White Variation		δW_{5p}	$\theta_x=0^\circ, \theta_y=0^\circ$	80	-	%	(5), (6), (7)	
		δW_{13p}		65	-			
Color Gamut				45			(7), (8)	

Note (1) Definition of Viewing Angle (θ_x , θ_y):

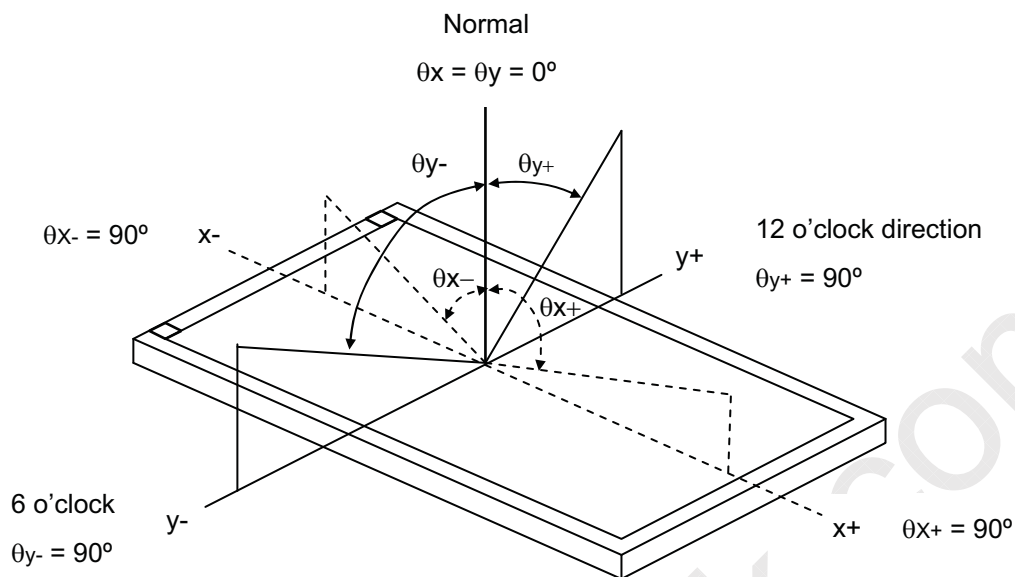

Note (2) Definition of Contrast Ratio (CR):

The contrast ratio can be calculated by the following expression.

$$\text{Contrast Ratio (CR)} = L_{63} / L_0$$

L63: Luminance of gray level 63

L 0: Luminance of gray level 0

$$\text{CR} = \text{CR} (1)$$

CR (X) is corresponding to the Contrast Ratio of the point X at Figure in Note (6).

Note (3) Definition of Response Time (T_R , T_F):

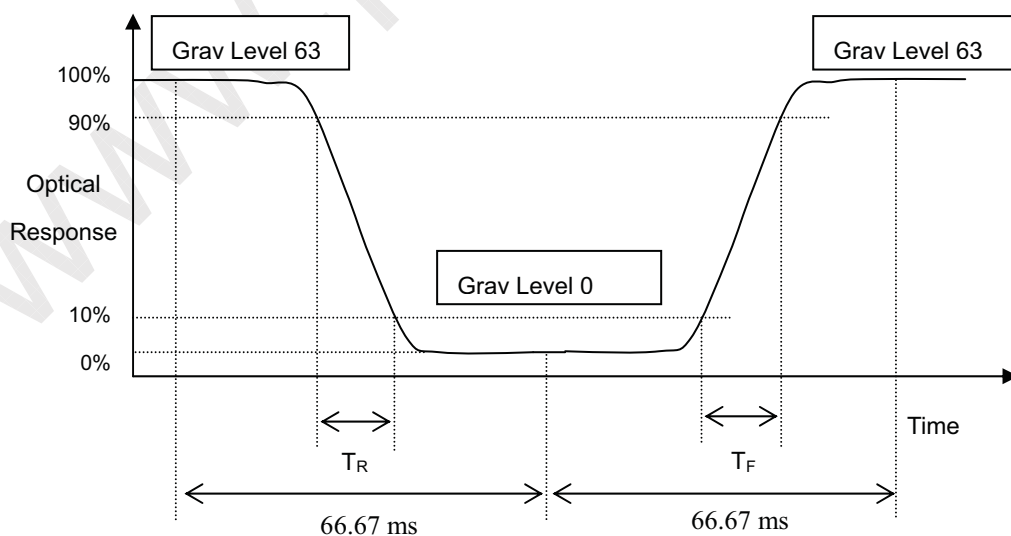

Note (4) Definition of Average Luminance of White (L_{AVE}):

Measure the luminance of gray level 63 at 5 points

$$L_{AVE} = [L(1) + L(2) + L(3) + L(4) + L(5)] / 5$$

$L(x)$ is corresponding to the luminance of the point X at Figure in Note (6).

Note (5) Measurement Setup:

The LCD module should be stabilized at given temperature for 20 minutes to avoid abrupt temperature change during measuring. In order to stabilize the luminance, the measurement should be executed after lighting Backlight for 20 minutes in a windless room.

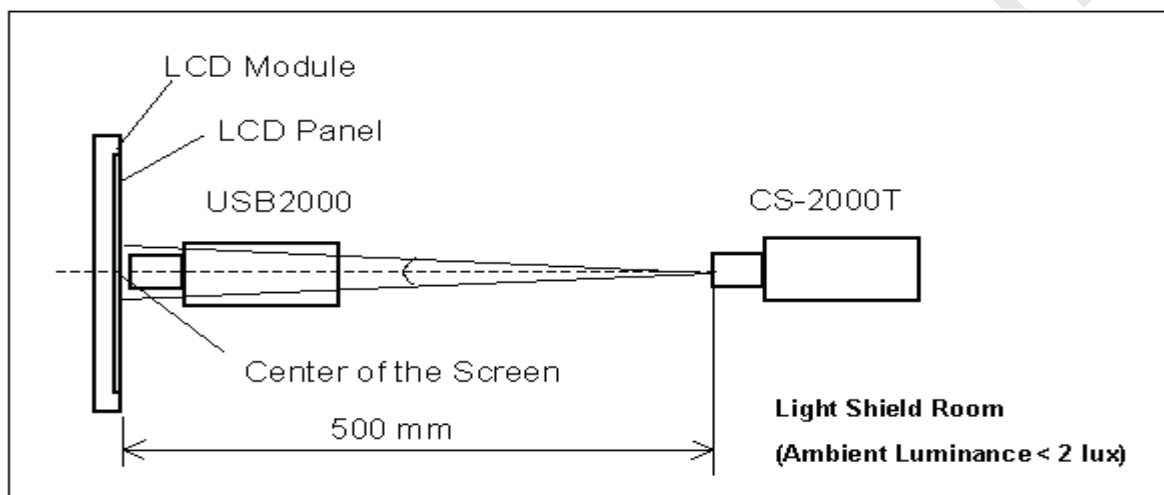
**Note (6) Definition of White Variation (δW):**

Measure the luminance of gray level 63 at 5 points

$$\delta W_{5p} = \{ \text{Minimum } [L(1) \sim L(5)] / \text{Maximum } [L(1) \sim L(5)] \} * 100\%$$

$$\delta W_{13p} = \{ \text{Minimum } [L(1) \sim L(13)] / \text{Maximum } [L(1) \sim L(13)] \} * 100\%$$

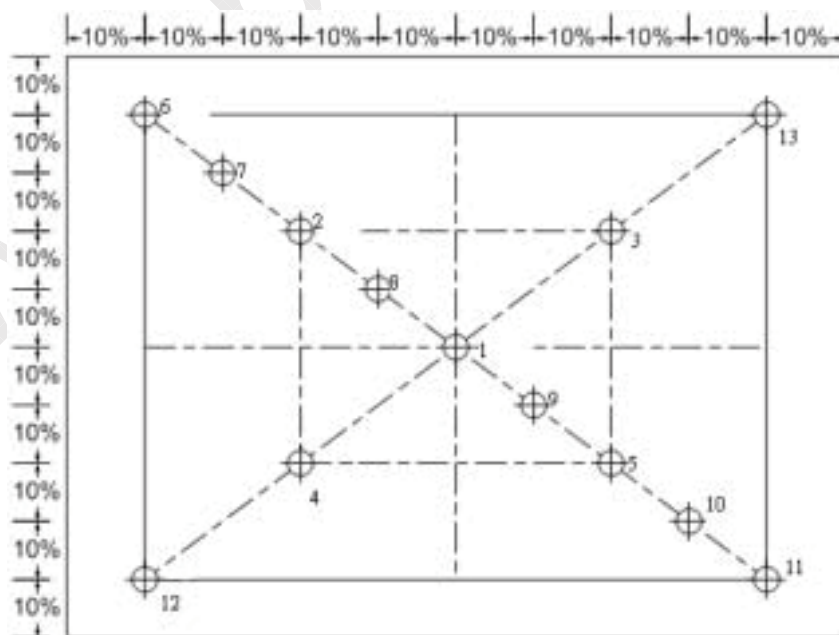

(X) : Test Point
X=1 to 13

Active area

Note (7) The listed optical specifications refer to the initial value of manufacture, but the condition of the specifications after long-term operation will not be warranted.

Note (8) Definition of color gamut (C.G%):

$$C.G\% = \frac{R G B}{R_0 G_0 B_0} \cdot 100\%$$

R_0, G_0, B_0 : color coordinates of red, green, and blue defined by NTSC, respectively.

R, G, B : color coordinates of module on 63 gray levels of red, green, and blue, respectively.

$R_0 G_0 B_0$: area of triangle defined by R_0, G_0, B_0

$R G B$: area of triangle defined by R, G, B

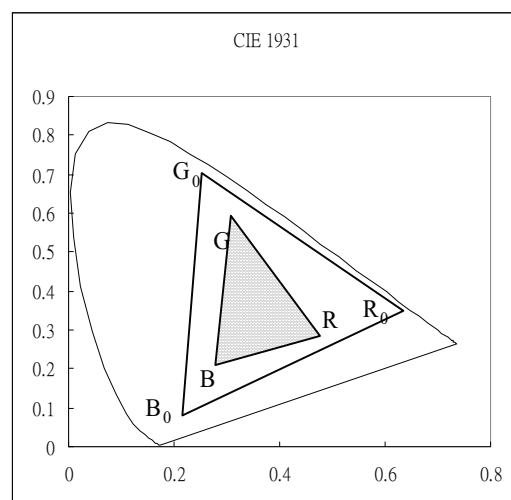

9. PRECAUTIONS

9.1 HANDLING PRECAUTIONS

- (1) The module should be assembled into the system firmly by using every mounting hole. Be careful not to twist or bend the module.
- (2) While assembling or installing modules, it can only be in the clean area. The dust and oil may cause electrical short or damage the polarizer.
- (3) Use fingerstalls or soft gloves in order to keep display clean during the incoming inspection and assembly process.
- (4) Do not press or scratch the surface harder than a HB pencil lead on the panel because the polarizer is very soft and easily scratched.
- (5) If the surface of the polarizer is dirty, please clean it by some absorbent cotton or soft cloth. Do not use Ketone type materials (ex. Acetone), Ethyl alcohol, Toluene, Ethyl acid or Methyl chloride. It might permanently damage the polarizer due to chemical reaction.
- (6) Wipe off water droplets or oil immediately. Staining and discoloration may occur if they left on panel for a long time.
- (7) If the liquid crystal material leaks from the panel, it should be kept away from the eyes or mouth. In case of contacting with hands, legs or clothes, it must be washed away thoroughly with soap.
- (8) Protect the module from static electricity, it may cause damage to the C-MOS Gate Array IC.
- (9) Do not disassemble the module.
- (10) Do not pull or fold the LED wire.
- (11) Pins of I/F connector should not be touched directly with bare hands.

9.2 STORAGE PRECAUTIONS

- (1) High temperature or humidity may reduce the performance of module. Please store LCD module within the specified storage conditions.
- (2) It is dangerous that moisture come into or contacted the LCD module, because the moisture may damage LCD module when it is operating.
- (3) It may reduce the display quality if the ambient temperature is lower than 10 °C. For example, the response time will become slowly, and the starting voltage of LED will be higher than the room temperature.

9.3 OPERATION PRECAUTIONS

- (1) Do not pull the I/F connector in or out while the module is operating.
- (2) Always follow the correct power on/off sequence when LCD module is connecting and operating. This can prevent the CMOS LSI chips from damage during latch-up.
- (3) The startup voltage of Backlight is approximately 1000 Volts. It may cause electrical shock while assembling with converter. Do not disassemble the module or insert anything into the Backlight unit.

10. SAFETY REVIEW

10.1 SAFETY STANDARDS

The LCD module should be certified with safety regulations as follows:

Requirement	Standard	Remark
UL	UL60950-1:2006 or Ed.2:2007	
cUL/CSA	CAN/CSA C22.2 No.60950-1-03 or 60950-1-07	
CB	IEC60950-1:2005 / EN60950-1:2006+ A11:2009	

11. PACKING

11.1 CARTON

Box Dimensions : 422(L)*286(W)*320(H)
Weight: Approx. 8.6kg(20 module .per. 1 box)

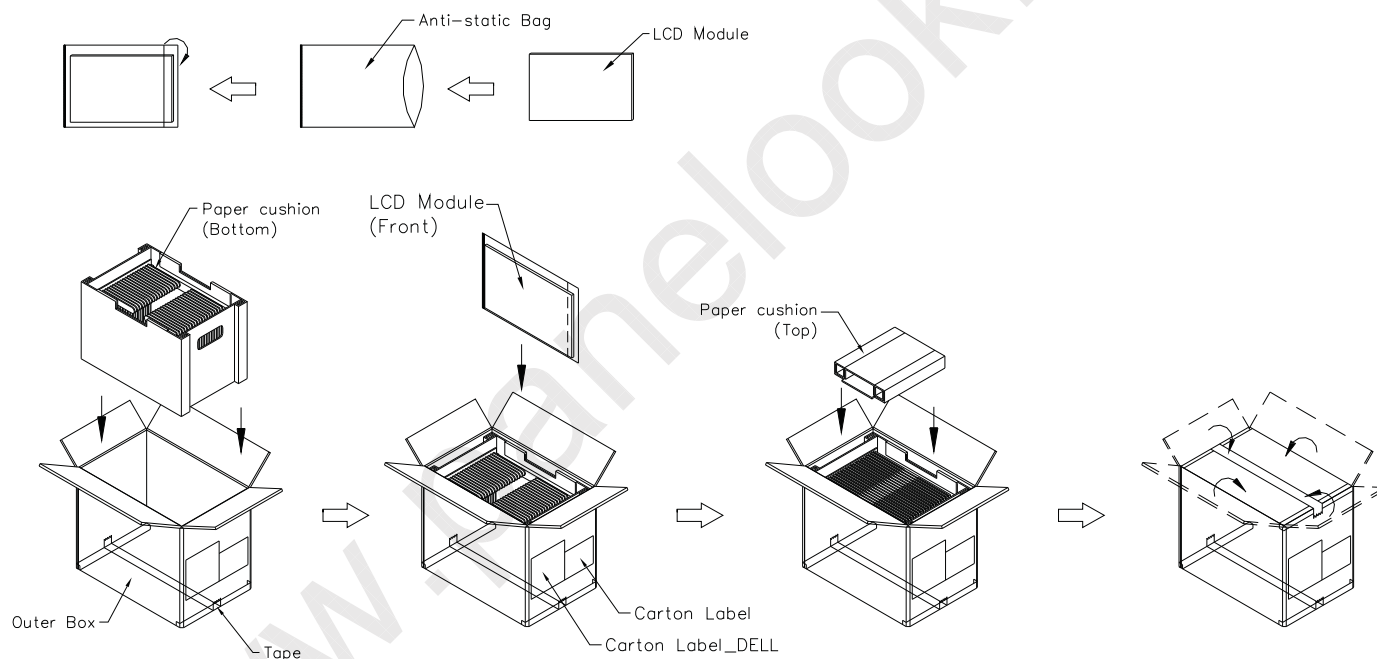

Figure. 11-1 Packing method

11.2 PALLET

Sea & Land Transportation

Air Transportation

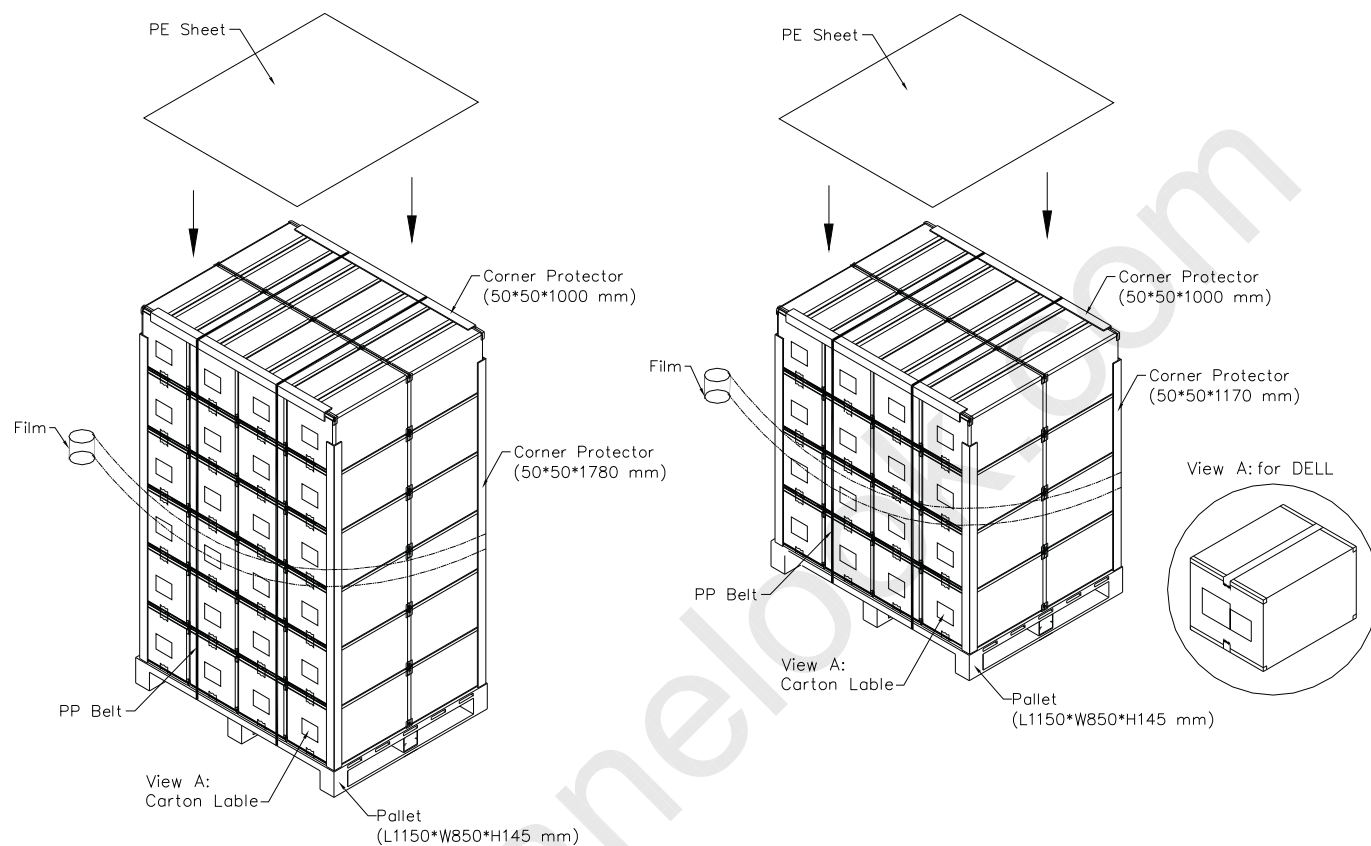

Figure. 11-2 Packing method

12. DEFINITION OF LABELS

12.1 CMO MODULE LABEL

The barcode nameplate is pasted on each module as illustration, and its definitions are as following explanation.



- (a) Model Name: N141I6-D11
- (b) Revision: Rev. XX, for example: A1,C1, C2 ...etc.
- (c) Serial ID: XXXXXXYYMDLNNNN

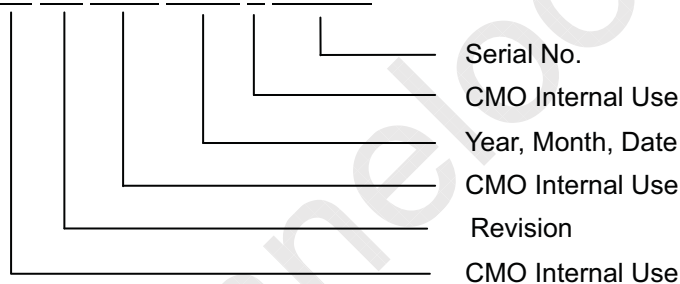

- (d) Production Location: MADE IN XXXX. XXXX stands for production location.
- (e) UL logo: "AAAA" especially stands for panel manufactured by CMO Ningbo satisfying UL requirement. "LEOO" is CMO's UL factory code for Ningbo factory.

Serial ID includes the information as below:

- (a) Manufactured Date: Year: 1~9, for 2001~2009
Month: 1~9, A~C, for Jan. ~ Dec.
Day: 1~9, A~Y, for 1st to 31st, exclude I, O and U
- (b) Revision Code: cover all the change
- (c) Serial No.: Manufacturing sequence of production

12.2 Dell MODULE LABEL

Dell 2D label contains information as below:

(a) Serial ID: CN-0SSSSS-70896-YMD-XXXX-ZZZ

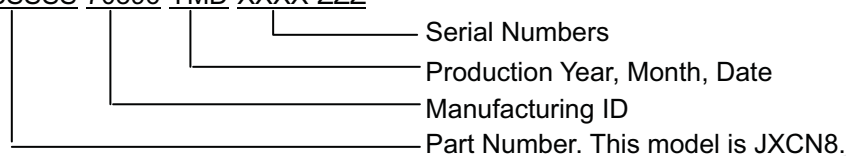

(b) Production location: Made in XXXX.

(c) ZZZ :Revision code: X00, X10, X20, A00..etc.

12.3 CMO CARTON LABEL

CHI MEI OPTOELECTRONICS

PO.No. _____

Part ID. _____

Model Name N141I6-D11

Carton ID. _____ Quantities 20

Lead Free

Made in XXXX

GP
RoHS

Production location: Made In XXXX. XXXX stands for production location.

12.4 DELL CARTON LABEL

Dell carton label contains information as below:



(a) PKG ID: 04688-70896-YMD-XXXXXX-0SSSSS-ZZ

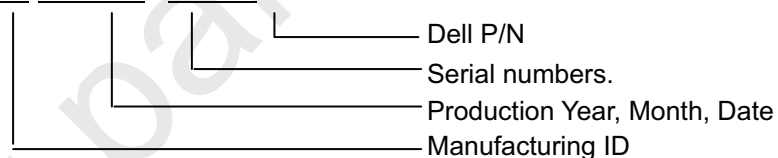

(b) Production location: Made in XXXX.

(c) Revision code: X00, X10, X20, A00..etc.

(d) BOX Quantity :ZZ

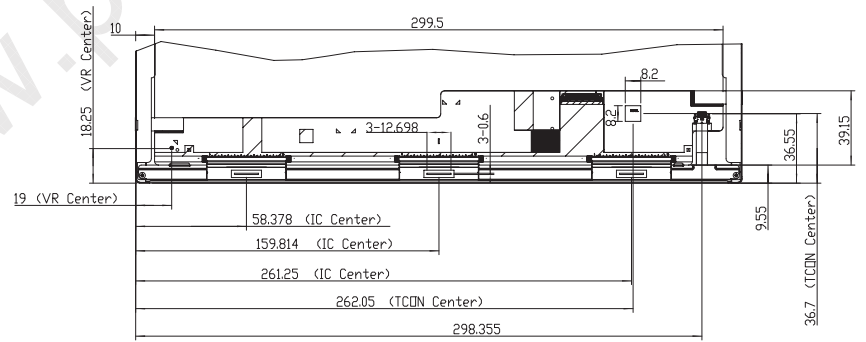
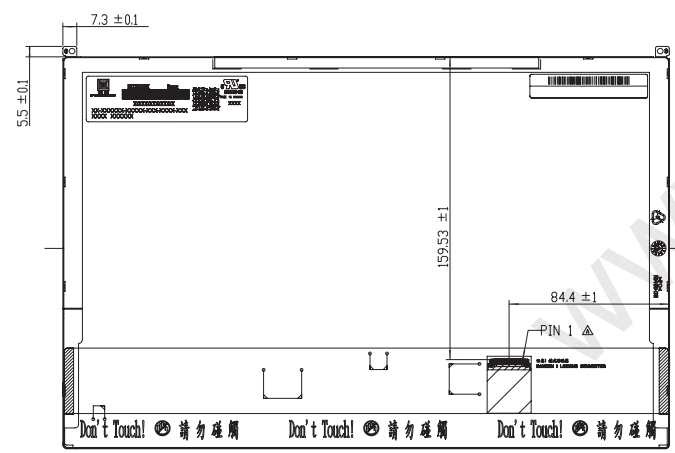
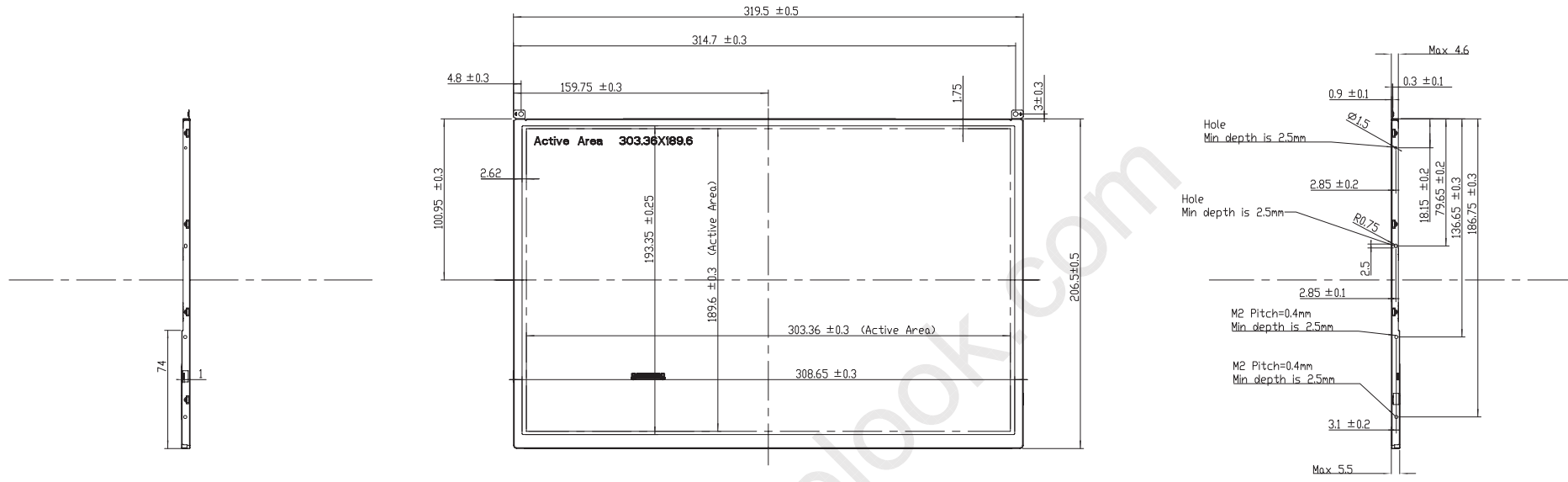

- NOTES
1. MAX. SCREW DEPTH 2.5mm
 2. MAX. SCREW TORQUE 2 kgf-cm
 3. LCD MIDDLE INPUT CONNECTOR (PIN 1) 20130408-01 OR EQUIVALENT
 4. GAP BETWEEN BEZEL AND PANEL 0.5mm MAX.
 5. IN ORDER TO AVOID ABNORMAL DISPLAY, POOLING AND WHITE SPOT, NO OVERLAPPING IS SUGGESTED AT CABLES, ANTENNAS, CAMERA, WLAN, WMM OR OTHER FOREIGN OBJECTS OVER TCON AND VR LOCATION.
 6. MIDDLE FLATNESS 0.5mm MAX.
 7. < > MARKS THE REFERENCE DIMENSIONS.

Mark	Description	Date	Changed_By	Approved_By	ECN No.	Remark
Δ	GLOBAL LCD EXCHANGE CENTER	2023-05-19	LENA	Shunan Cheng	FAB007581	

TITLE OUTLINE DRAWING 16410-011		REV. 1.0	
Approved	SHUNAN CHENG	Drawing No.	16410A011
Checked	EXCHANGE	Part No.	NA
Drawn	LENA	Material	NA
Designer	LENA	Date	2023-05-19
Scale		1:1	
CHI MEI OPTOELECTRONICS CORP.		ALL RIGHTS RESERVED. OFF-PANEL FORBIDDEN.	