



## TFT LCD Preliminary Specification

# MODEL NO.: N141I6 - L03

Customer :

Approved by : \_\_\_\_\_

Note :

核准時間	部門	審核	角色	投票
2009-04-10 16:30:51	NB 產品管理處	徐 2009.04.10 凡 琇	Director	Accept

**- CONTENTS -**

<b>REVISION HISTORY</b>	-----	3
<b>1. GENERAL DESCRIPTION</b>	-----	4
1.1 OVERVIEW		
1.2 FEATURES		
1.3 APPLICATION		
1.4 GENERAL SPECIFICATIONS		
1.5 MECHANICAL SPECIFICATIONS		
<b>2. ABSOLUTE MAXIMUM RATINGS</b>	-----	5
2.1 ABSOLUTE RATINGS OF ENVIRONMENT		
2.2 ELECTRICAL ABSOLUTE RATINGS		
2.2.1 TFT LCD MODULE		
2.2.2 BACKLIGHT UNIT		
<b>3. ELECTRICAL CHARACTERISTICS</b>	-----	7
3.1 TFT LCD MODULE		
3.2 BACKLIGHT UNIT		
<b>4. BLOCK DIAGRAM</b>	-----	10
4.1 TFT LCD MODULE		
<b>5. INPUT TERMINAL PIN ASSIGNMENT</b>	-----	11
5.1 TFT LCD MODULE		
5.2 BACKLIGHT UNIT		
5.3 TIMING DIAGRAM OF LVDS INPUT SIGNAL		
5.4 COLOR DATA INPUT ASSIGNMENT		
5.5 EDID DATA STRUCTURE		
<b>6. CONVERTER SPECIFICATION</b>	-----	
6.1 ABSOLUTE MAXIMUM RATINGS		
6.2 RECOMMENDED OPERATING RATINGS		
<b>7. INTERFACE TIMING</b>	-----	14
7.1 INPUT SIGNAL TIMING SPECIFICATIONS		
7.2 POWER ON/OFF SEQUENCE		
<b>8. OPTICAL CHARACTERISTICS</b>	-----	20
8.1 TEST CONDITIONS		
8.2 OPTICAL SPECIFICATIONS		
<b>9. PRECAUTIONS</b>	-----	24
9.1 HANDLING PRECAUTIONS		
9.2 STORAGE PRECAUTIONS		
9.3 OPERATION PRECAUTIONS		
9.4 OTHER OPERATION PRECAUTIONS		
9.5 SAFTY STANDARD		
<b>10. PACKING</b>	-----	26
10.1 CARTON		
10.2 PALLET		
<b>11. DEFINITION OF LABELS</b>	-----	28
11.1 CMO MODULE LABEL		
11.2 CMO CARTON LABEL		

**REVISION HISTORY**

Version	Date	Page (New)	Section	Description
1.0	Mar.23, 2009	All	All	Preliminary specification was first issued.

## 1 GENERAL DESCRIPTION

### 1.1 OVERVIEW

N141I6 - L03 is a 14.1" TFT Liquid Crystal Display module with white LED Backlight unit and 30 pins LVDS interface. This module supports 1280 x 800 WXGA mode and can display 262,144 colors. The optimum viewing angle is at 6 o'clock direction. The converter module for backlight is not built in.

### 1.2 FEATURES

- White LED Backlight
- WXGA (1280 x 800 pixels) resolution.
- Follow VESA standard.
- 3.3V LVDS (Low Voltage Differential Signaling) interface with 1 pixel/clock

### 1.3 APPLICATION

- TFT LCD Notebook

### 1.4 GENERAL SPECIFICATIONS

Item	Specification	Unit	Note
Active Area	303.36(H) X 189.6(V)	mm	(1)
Bezel Opening Area	306.76 (H) x 193 (V)	mm	
Driver Element	a-si TFT active matrix	-	-
Pixel Number	1280 x R.G.B. x 800	pixel	-
Pixel Pitch	0.237 (H) x 0.237 (V)	mm	-
Pixel Arrangement	RGB vertical stripe	-	-
Display Colors	262,144	color	-
Transmissive Mode	Normally white	-	-
Surface Treatment	Glare, 3H	-	-

### 1.5 MECHANICAL SPECIFICATIONS

Item		Min.	Typ.	Max.	Unit	Note
Module Size	Horizontal(H)	319	319.5	320	mm	(1)
	Vertical(V)	205	205.5	206	mm	
	Depth(D)	--	5.2	5.5	mm	
Weight		--	420	435	g	(2)

Note (1) Please refer to the attached drawings for more information of front and back outline dimensions

(2) Weight without converter

## 2 ABSOLUTE MAXIMUM RATINGS

### 2.1 ABSOLUTE RATINGS OF ENVIRONMENT

Item	Symbol	Value		Unit	Note
		Min.	Max.		
Storage Temperature	$T_{ST}$	-20	+60	°C	(1)
Operating Ambient Temperature	$T_{OP}$	0	+50	°C	(1), (2)
Shock (Non-Operating)	$S_{NOP}$	-	220/2	G/ms	(3), (5)
Vibration (Non-Operating)	$V_{NOP}$	-	1.5	G	(4), (5)

Note (1) Temperature and relative humidity range is shown in the figure below.

(a) 90 %RH Max. ( $T_a \leq 40$  °C).

(b) Wet-bulb temperature should be 39 °C Max. ( $T_a > 40$  °C).

(c) No condensation.

Note (2) The ambient temperature means the temperature of panel surface.

Note (3) 1 time for  $\pm X$ ,  $\pm Y$ ,  $\pm Z$ . for Condition (220G / 2ms) is half Sine Wave,.

Note (4) 10 ~ 500 Hz, 30 min / Cycle, 1 cycles for each X, Y, Z axis. The fixing condition is shown as below:

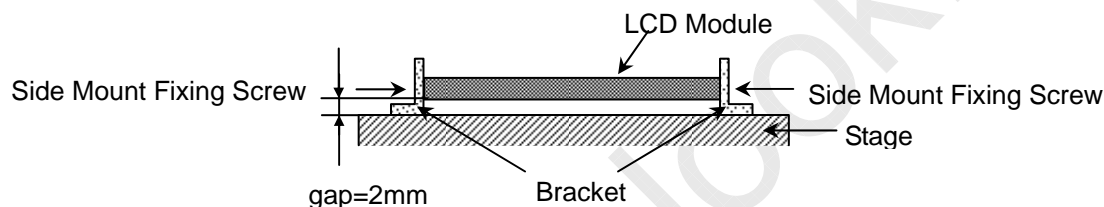

Note (5) At testing Vibration and Shock, the fixture in holding the module has to be hard and rigid enough so that the module would not be twisted or bent by the fixture.

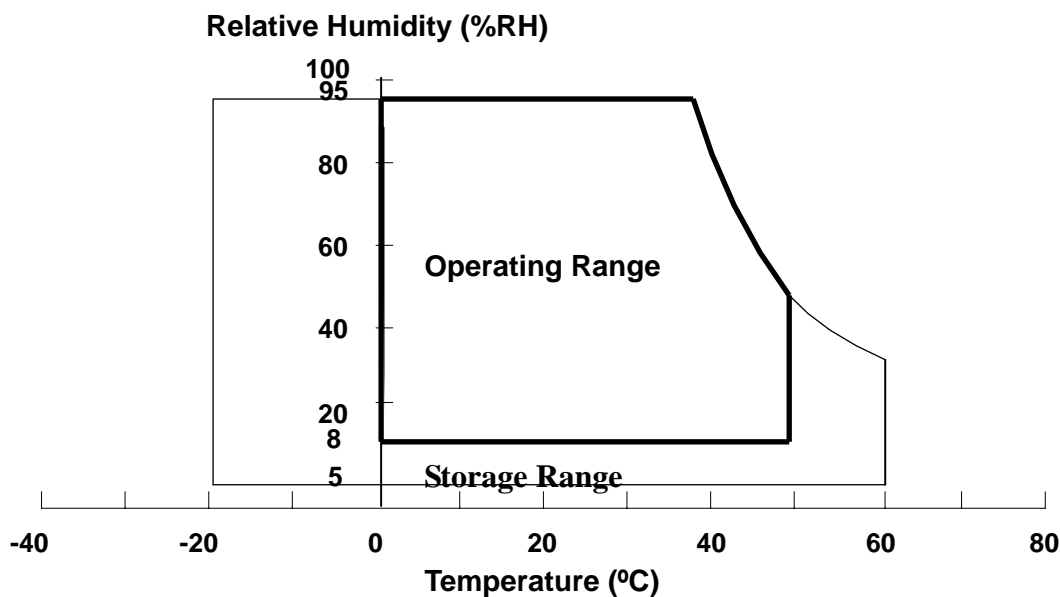



## 2.2 ELECTRICAL ABSOLUTE RATINGS

### 2.2.1 TFT LCD MODULE

Item	Symbol	Value		Unit	Note
		Min.	Max.		
Power Supply Voltage	$V_{CC}$	-0.3	+4.0	V	(1)
Logic Input Voltage	$V_{IN}$	-0.3	$V_{CC}+0.3$	V	

### 2.2.2 BACKLIGHT UNIT

Item	Symbol	Value		Unit	Note
		Min.	Max.		
LED Light Bar Power Supply Voltage	$V_L$	-40	27.2	V	(1), (2)
LED Light Bar Power Supply Current	$I_L$	0	150	mA	

Note (1) Permanent damage to the device may occur if maximum values are exceeded. Function operation should be restricted to the conditions described under Normal Operating Conditions.

Note (2) Specified values are for LED (Refer to 3.2 for further information).

### 3 ELECTRICAL CHARACTERISTICS

#### 3.1 TFT LCD MODULE

 $T_a = 25 \pm 2 \text{ }^\circ\text{C}$ 

Parameter	Symbol	Value			Unit	Note
		Min.	Typ.	Max.		
Power Supply Voltage	V <sub>CC</sub>	3.0	3.3	3.6	V	-
Permissible Ripple Voltage	V <sub>RP</sub>		50		mV	-
Rush Current	I <sub>RUSH</sub>			1.5	A	(2)
Initial Stage Current	I <sub>IS</sub>			1.0	A	(2)
Power Supply Current	White		(235)	(255)	mA	(3)a
	Black		(300)	(330)	mA	(3)b
LVDS Differential Input High Threshold	V <sub>TH(LVDS)</sub>			+100	mV	(5), V <sub>CM</sub> =1.2V
LVDS Differential Input Low Threshold	V <sub>TL(LVDS)</sub>	-100			mV	(5) V <sub>CM</sub> =1.2V
LVDS Common Mode Voltage	V <sub>CM</sub>	1.125		1.375	V	(5)
LVDS Differential Input Voltage	V <sub>ID</sub>	100		600	mV	(5)
Terminating Resistor	R <sub>T</sub>		100		Ohm	
Power per EBL WG	P <sub>EBL</sub>	-	TBD		W	(4)

Note (1) The ambient temperature is  $T_a = 25 \pm 2 \text{ }^\circ\text{C}$ .

Note (2) I<sub>RUSH</sub>: the maximum current when VCC is rising

I<sub>IS</sub>: the maximum current of the first 100ms after power-on

Measurement Conditions: Shown as the following figure. Test pattern: black.

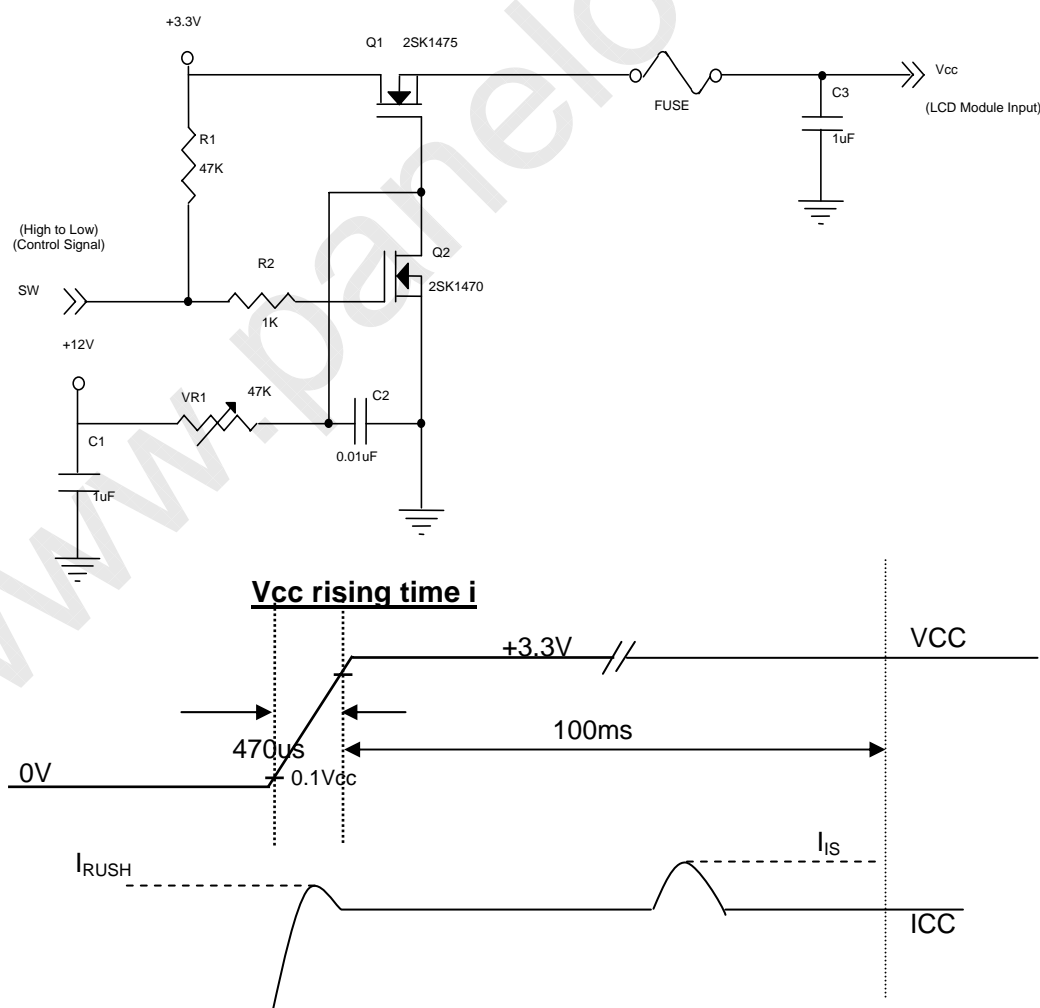

Note (3) The specified power supply current is under the conditions at  $V_{CC} = 3.3 \text{ V}$ ,  $T_a = 25 \pm 2 \text{ }^\circ\text{C}$ ,  $f_v = 60 \text{ Hz}$ , whereas a power dissipation check pattern below is displayed.

a. White Pattern

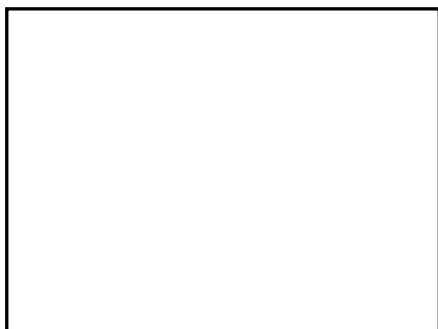

Active Area

b. Black Pattern

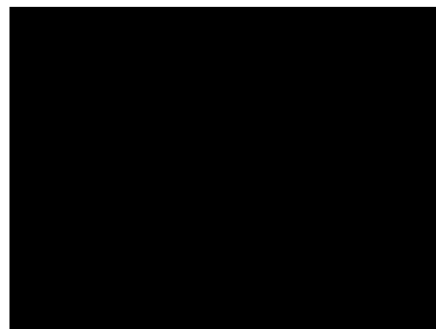

Active Area

Note (4) The specified power are the sum of LCD panel electronics input power and the converter input power. Test conditions are as follows.

- (a)  $V_{CC} = 3.3 \text{ V}$ ,  $T_a = 25 \pm 2 \text{ }^\circ\text{C}$ ,  $f_v = 60 \text{ Hz}$ ,
- (b) The pattern used is a black and white 32 x 36 checkerboard, slide #100 from the VESA file "Flat Panel Display Monitor Setup Patterns", FPDMSU.ppt.
- (c) Luminance: 60 nits.

Note (5) The parameters of LVDS signals are defined as the following figures.

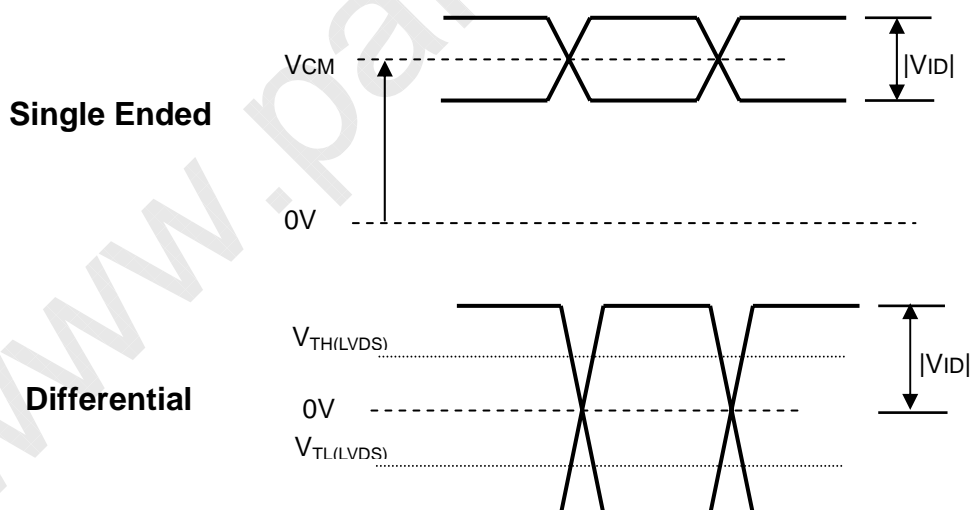



## 3.2 BACKLIGHT UNIT

Ta = 25 ± 2 °C

Parameter	Symbol	Value			Unit	Note
		Min.	Typ.	Max.		
LED light bar Power Supply Voltage	V <sub>L</sub>	24	25.6	27.2	V <sub>dc</sub>	(1), (2)
LED light bar Power Supply Current	I <sub>L</sub>	114	120	126	mA	
LED Life Time	L <sub>BL</sub>	15,000	--	--	Hrs	(4)
Power Consumption	P <sub>L</sub>	2.736	3.024	3.427	W	(3),Duty=100%

Note (1) LED light bar configuration is shown as below:

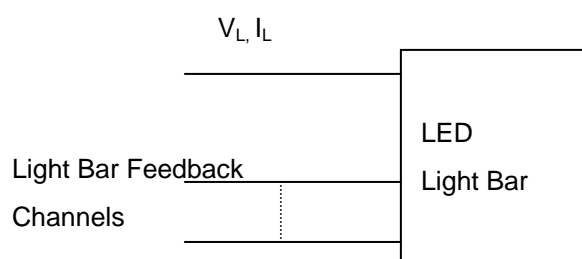

Note (2) For better LED light bar driving quality, it is recommended to utilize the adaptive boost converter with current balancing function to drive LED light-bar.

Note (3)  $P_L = I_L \times V_L$

Note (4) The lifetime of LED is defined as the time when it continues to operate under the conditions at Ta = 25 ± 2 °C and I<sub>L</sub> = 20.0 mA(Per EA) until the brightness becomes 50% of its original value.

## 4 BLOCK DIAGRAM

### 4.1 TFT LCD MODULE

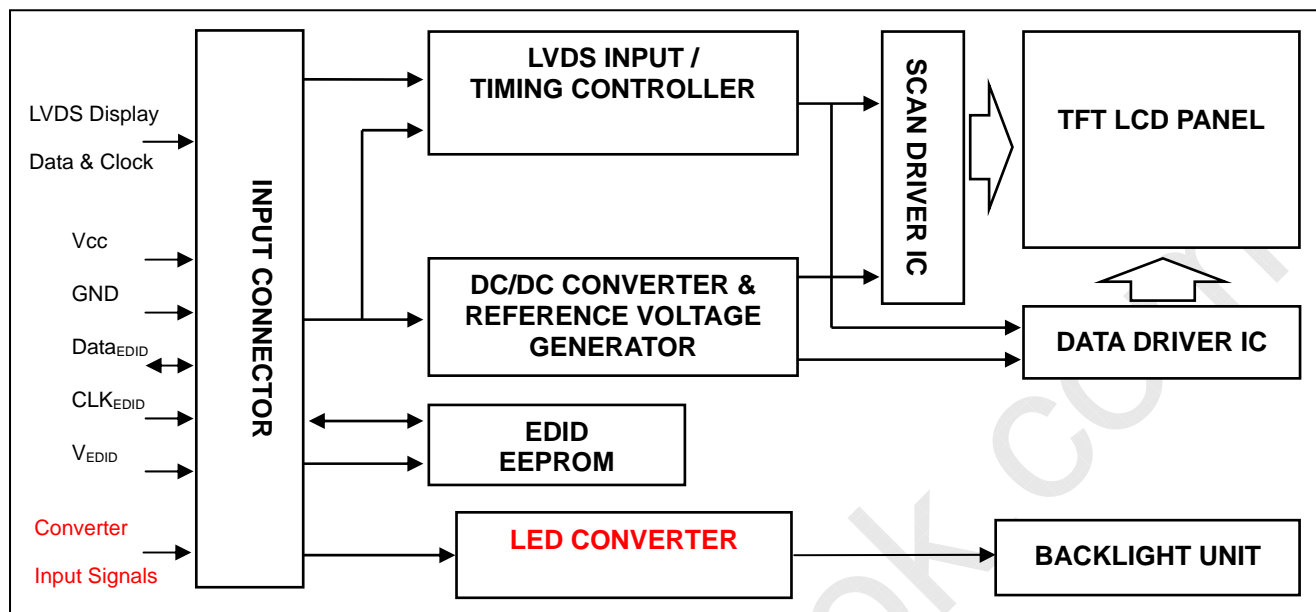

## 5 INPUT TERMINAL PIN ASSIGNMENT

### 5.1 TFT LCD MODULE

Pin	Symbol	Description	Polarity	Remark
1	VSS	Ground		
2	VDD	Power Supply (3.3V typ.)		
3	VDD	Power Supply (3.3V typ.)		
4	V <sub>EDID</sub>	DDC 3.3V Power		
5	NC	No Connection (Reserved for CMO test)		
6	CLK <sub>EDID</sub>	DDC Clock		
7	DATA <sub>EDID</sub>	DDC Data		
8	Rxin0-	LVDS Differential Data Input	Negative	R0~R5,G0
9	Rxin0+	LVDS Differential Data Input	Positive	
10	VSS	Ground		
11	Rxin1-	LVDS Differential Data Input	Negative	G1~G5, B0, B1
12	Rxin1+	LVDS Differential Data Input	Positive	
13	VSS	Ground		
14	Rxin2-	LVDS Differential Data Input	Negative	B2-B5,HS,VS, DE
15	Rxin2+	LVDS Differential Data Input	Positive	
16	VSS	Ground		
17	RxCLK-	LVDS differential clock input	Negative	
18	RxCLK+	LVDS differential clock input	Positive	
19	VSS	Ground		
20	NC	No Connection (Reserve)		
21	NC	No Connection (Reserve)		
22	VSS	Ground		
23	NC	No Connection (Reserve)		
24	NC	No Connection (Reserve)		
25	VSS	Ground		
26	NC	No Connection (Reserve)		
27	NC	No Connection (Reserve)		
28	VSS	Ground		
29	NC	No Connection (Reserve)		
30	NC	No Connection (Reserve)		
31	LED_GND	LED Ground		
32	LED_GND	LED Ground		
33	LED_GND	LED Ground		
34	NC	No Connection (Reserve)		
35	LED_PWM	PWM Control Signal of LED Converter		
36	LED_EN	Enable Control Signal of LED Converter		
37	NC	No Connection (Reserve)		
38	LED_VCCS	LED Power		
39	LED_VCCS	LED Power		
40	LED_VCCS	LED Power		

Note (1) Connector Part No.: I-PEX 20455-040E-12 or equivalent

Note (2) User's connector Part No: I-PEX 20453-040T-12 or equivalent

Note (3) The first pixel is odd.

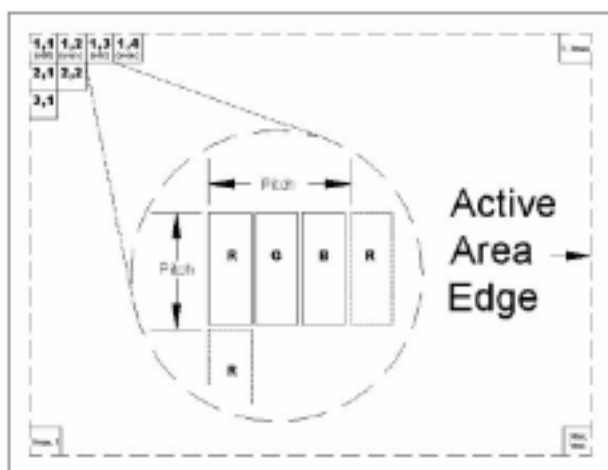

## 5.2 TIMING DIAGRAM OF LVDS INPUT SIGNAL

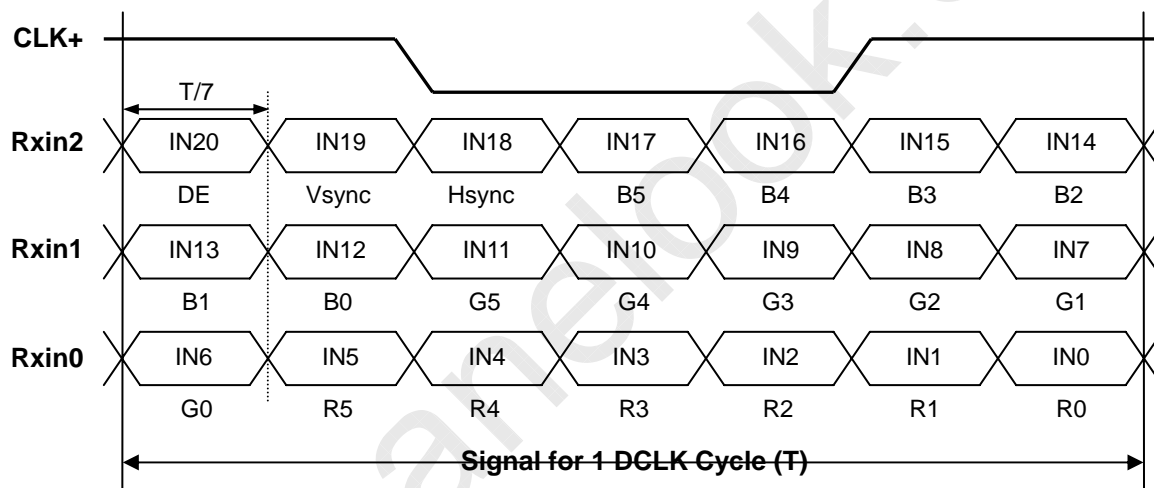



**Preliminary**

### 5.3 COLOR DATA INPUT ASSIGNMENT

The brightness of each primary color (red, green and blue) is based on the 6-bit gray scale data input for the color. The higher the binary input, the brighter the color. The table below provides the assignment of color versus data input.

Color		Data Signal																	
		Red						Green						Blue					
		R5	R4	R3	R2	R1	R0	G5	G4	G3	G2	G1	G0	B5	B4	B3	B2	B1	B0
Basic Colors	Black	0	0	0	0	0	0	0	0	0	0	0	0	0	0	0	0	0	0
	Red	1	1	1	1	1	1	0	0	0	0	0	0	0	0	0	0	0	0
	Green	0	0	0	0	0	0	1	1	1	1	1	1	0	0	0	0	0	0
	Blue	0	0	0	0	0	0	0	0	0	0	0	0	1	1	1	1	1	1
	Cyan	0	0	0	0	0	0	1	1	1	1	1	1	1	1	1	1	1	1
	Magenta	1	1	1	1	1	1	0	0	0	0	0	0	1	1	1	1	1	1
	Yellow	1	1	1	1	1	1	1	1	1	1	1	1	0	0	0	0	0	0
	White	1	1	1	1	1	1	1	1	1	1	1	1	1	1	1	1	1	1
Gray Scale Of Red	Red(0)/Dark	0	0	0	0	0	0	0	0	0	0	0	0	0	0	0	0	0	0
	Red(1)	0	0	0	0	0	1	0	0	0	0	0	0	0	0	0	0	0	0
	Red(2)	0	0	0	0	1	0	0	0	0	0	0	0	0	0	0	0	0	0
	:	:	:	:	:	:	:	:	:	:	:	:	:	:	:	:	:	:	:
	:	:	:	:	:	:	:	:	:	:	:	:	:	:	:	:	:	:	:
	Red(61)	1	1	1	1	0	1	0	0	0	0	0	0	0	0	0	0	0	0
	Red(62)	1	1	1	1	1	0	0	0	0	0	0	0	0	0	0	0	0	0
	Red(63)	1	1	1	1	1	1	0	0	0	0	0	0	0	0	0	0	0	0
Gray Scale Of Green	Green(0)/Dark	0	0	0	0	0	0	0	0	0	0	0	0	0	0	0	0	0	0
	Green(1)	0	0	0	0	0	0	0	0	0	0	1	0	0	0	0	0	0	
	Green(2)	0	0	0	0	0	0	0	0	0	0	1	0	0	0	0	0	0	
	:	:	:	:	:	:	:	:	:	:	:	:	:	:	:	:	:	:	
	:	:	:	:	:	:	:	:	:	:	:	:	:	:	:	:	:	:	
	Green(61)	0	0	0	0	0	0	1	1	1	1	0	1	0	0	0	0	0	
	Green(62)	0	0	0	0	0	0	1	1	1	1	1	0	0	0	0	0	0	
	Green(63)	0	0	0	0	0	0	1	1	1	1	1	1	0	0	0	0	0	
Gray Scale Of Blue	Blue(0)/Dark	0	0	0	0	0	0	0	0	0	0	0	0	0	0	0	0	0	0
	Blue(1)	0	0	0	0	0	0	0	0	0	0	0	0	0	0	0	0	0	1
	Blue(2)	0	0	0	0	0	0	0	0	0	0	0	0	0	0	0	0	1	0
	:	:	:	:	:	:	:	:	:	:	:	:	:	:	:	:	:	:	:
	:	:	:	:	:	:	:	:	:	:	:	:	:	:	:	:	:	:	:
	Blue(61)	0	0	0	0	0	0	0	0	0	0	0	0	1	1	1	1	0	1
	Blue(62)	0	0	0	0	0	0	0	0	0	0	0	0	1	1	1	1	1	0
	Blue(63)	0	0	0	0	0	0	0	0	0	0	0	0	1	1	1	1	1	1

Note (1) 0: Low Level Voltage, 1: High Level Voltage

## 5.4 EDID DATA STRUCTURE

The EDID (Extended Display Identification Data) data formats are to support displays as defined in the VESA Plug & Display and FPD1 standards.

Byte # (decimal)	Byte # (hex)	Field Name and Comments	Value (hex)	Value (binary)
0	0	Header , Fixed	00	00000000
1	1	Header , Fixed	FF	11111111
2	2	Header , Fixed	FF	11111111
3	3	Header , Fixed	FF	11111111
4	4	Header , Fixed	FF	11111111
5	5	Header , Fixed	FF	11111111
6	6	Header , Fixed	FF	11111111
7	7	Header , Fixed	00	00000000
8	8	ID system manufacturer name	30	00110000
9	9	ID system manufacturer name	AE	10101110
10	0A	ID system Product Code (LSB)	35	00110101
11	0B	ID system Product Code (MSB)	40	01000000
12	0C	32-bit serial # Unused(01h for VESA, 00h for SPWG)	00	00000000
13	0D	32-bit serial # Unused(01h for VESA, 00h for SPWG)	00	00000000
14	0E	32-bit serial # Unused(01h for VESA, 00h for SPWG)	00	00000000
15	0F	32-bit serial # Unused(01h for VESA, 00h for SPWG)	00	00000000
16	10	Week of manufacture 1 - 53 (unused: 00h) : 10h fixed by CMO	10	00010000
17	11	Year of manufacture year - 1990(unsed:00h) : 13h (Year 2009) fixed by CMO	13	00010011
18	12	Version=1	01	00000001
19	13	Revision=3	03	00000011
20	14	Digital	80	10000000
21	15	Active area horizontal 303.36cm	1E	00011110
22	16	Active area vertical 189.6cm	13	00010011
23	17	gamma * 100-100 = 2.2*100-100=120	78	01111000
24	18	Feature support (no DPMS, Active off, RGB, Preferred Timing Mode)	EA	11101010
25	19	Rx1 Rx0 Ry1 Ry0 Gx1 Gx0 Gy1 Gy0	93	10010011
26	1A	Bx1 Bx0 By1 By0 Wx1 Wx0 Wy1 Wy0	65	01100101
27	1B	Rx=0.58	94	10010100
28	1C	Ry=0.349	59	01011001
29	1D	Gx=0.336	56	01010110
30	1E	Gy=0.569	91	10010001
31	1F	Bx=0.157	28	00101000
32	20	By=0.135	22	00100010
33	21	Wx=0.313	50	01010000
34	22	Wy=0.329	54	01010100
35	23	Established timings 1	00	00000000
36	24	Established timings 2 (1280x800@60Hz)	00	00000000
37	25	No manufacturer's specific timing	00	00000000
38	26	Standard timing ID # 1	01	00000001
39	27	Standard timing ID # 1	01	00000001
40	28	Standard timing ID # 2	01	00000001
41	29	Standard timing ID # 2	01	00000001
42	2A	Standard timing ID # 3	01	00000001



43	2B	Standard timing ID # 3	01	00000001
44	2C	Standard timing ID # 4	01	00000001
45	2D	Standard timing ID # 4	01	00000001
46	2E	Standard timing ID # 5	01	00000001
47	2F	Standard timing ID # 5	01	00000001
48	30	Standard timing ID # 6	01	00000001
49	31	Standard timing ID # 6	01	00000001
50	32	Standard timing ID # 7	01	00000001
51	33	Standard timing ID # 7	01	00000001
52	34	Standard timing ID # 8	01	00000001
53	35	Standard timing ID # 8	01	00000001
54	36	Detailed timing description # 1 Pixel clock ("69.29MHz", According to VESA CVT Rev1.1)	11	00010001
55	37	69.29MHz/10000 =6929=1B11(Hex)	1B	00011011
56	38	HActive(D7-D0) = 1280 mod 256	00	00000000
57	39	HBlank(D7-D0) = 125 mod 256	7D	01111101
58	3A	HActive(D11-D8) : HBlank(D11-D8) = 1280/256 : 125/256	50	01010000
59	3B	VActive(D7-D0) =800 mod 256	20	00100000
60	3C	VBlank(D7-D0) = 22 mod 256	16	00010110
61	3D	VActive(D11-D8) : VBlank(D11-D8) = 800/256 : 22/256	30	00110000
62	3E	HSyncOffset(D7-D0) = HBorder+HFrontPorch = 48	30	00110000
63	3F	HSyncWidth(D7-D0) = 32	20	00100000
64	40	VSynOffset(D3-D0)=3 : VSynWidth(D3-D0)=6	36	00110110
65	41	HSynOffset(D9-D8) : HSynWidth(D9-D8) : VSynOffset(D5-D4) : VSynWidth(D5-D4)	00	00000000
66	42	HImageSize(mm, D7-D0) = 303mod 256	2F	00101111
67	43	VImageSize(mm, D7-D0) = 190mod 256	BE	10111110
68	44	HImageSize(D11-D8) : VImageSize(D11-D8) = 303/256 : 190/256	10	00010000
69	45	Horizontal Border=0	00	00000000
70	46	Vertical Border=0	00	00000000
71	47	Non-interlaced, Normal Display, Digital separate, Positive Hsync, Negative Vsync	18	00011000
72	48	Detailed timing description # 1 Pixel clock ("57.74MHz", According to VESA CVT Rev1.1)	8E	10001110
73	49	57.74MHz/10000 =5774=168E(Hex)	16	00010110
74	4A	HActive(D7-D0) = 1280 mod 256	00	00000000
75	4B	HBlank(D7-D0) = 125 mod 256	7D	01111101
76	4C	HActive(D11-D8) : HBlank(D11-D8) = 1280/256 : 125/256	50	01010000
77	4D	VActive(D7-D0) =800 mod 256	20	00100000
78	4E	VBlank(D7-D0) = 22 mod 256	16	00010110
79	4F	VActive(D11-D8) : VBlank(D11-D8) = 800/256 : 22/256	30	00110000
80	50	HSyncOffset(D7-D0) = HBorder+HFrontPorch = 48	30	00110000
81	51	HSyncWidth(D7-D0) = 32	20	00100000
82	52	VSynOffset(D3-D0)=3 : VSynWidth(D3-D0)=6	36	00110110
83	53	HSynOffset(D9-D8) : HSynWidth(D9-D8) : VSynOffset(D5-D4) : VSynWidth(D5-D4)	00	00000000
84	54	HImageSize(mm, D7-D0) = 303mod 256	2F	00101111
85	55	VImageSize(mm, D7-D0) = 190mod 256	BE	10111110
86	56	HImageSize(D11-D8) : VImageSize(D11-D8) = 303/256 : 190/256	10	00010000
87	57	Horizontal Border=0	00	00000000
88	58	Vertical Border=0	00	00000000



89	59	Non-interlaced, Normal Display, Digital separate, Positive Hsync, Negative Vsync	18	00011000
90	5A	Flag	00	00000000
91	5B	Flag	00	00000000
92	5C	Flag	00	00000000
93	5D	Data type tag :0F	0F	00001111
94	5E	Flag	00	00000000
95	5F	Low Refresh Rate #1 (Horizontal active pixels / 8 ) - 31=129(81h)	81	10000001
96	60	Low Refresh Rate #1 Image Aspect ratio(16 : 10)	0A	00001010
97	61	Low Refresh Rate #1 Refresh Rate=50Hz	32	00110010
98	62	Low Refresh Rate #2 (Horizontal active pixels / 8 ) - 31=129(81h)	81	10000001
99	63	Low Refresh Rate #2 Image Aspect ratio(16 : 10)	0A	00001010
100	64	Low Refresh Rate #2 Refresh Rate=40Hz	28	00101000
101	65	Brightness (1/10nit) , 220/10=22(=16h)	16	00010110
102	66	Feature Flags	09	00001001
103	67	Reserved	00	00000000
104	68	EISA manufacturer code(3 Character ID) -CMO	0D	00001101
105	69	Compressed ASCII	AF	10101111
106	6A	Panel Supplier Reserved - Product code -1455	55	01010101
107	6B	(Hex, LSB first)	14	00010100
108	6C	Flag	00	00000000
109	6D	Flag	00	00000000
110	6E	Flag	00	00000000
111	6F	Data type tag : FEh	FE	11111110
112	70	Flag	00	00000000
113	71	"N"	4E	01001110
114	72	"1"	31	00110001
115	73	"4"	34	00110100
116	74	"1"	31	00110001
117	75	"I"	49	01001001
118	76	"6"	36	00110110
119	77	"-"	2D	00101101
120	78	"L"	4C	01001100
121	79	"0"	30	00110000
122	7A	"3"	33	00110011
123	7B	(If <13 char, then terminate with ASCII code 0Ah, set remaining char = 20h)	0A	00001010
124	7C	(If <13 char, then terminate with ASCII code 0Ah, set remaining char = 20h)	20	00100000
125	7D	(If <13 char, then terminate with ASCII code 0Ah, set remaining char = 20h)	20	00100000
126	7E	No extension	00	00000000
127	7F	One-byte checksum of entire 128 bytes EDID equals 00h.	F9	11111001



## 6. CONVERTER SPECIFICATION

### 6.1 ABSOLUTE MAXIMUM RATINGS

Symbol	Ratings
LED_VCCS	6~40 V
LED_PWM, LED_EN	-0.3V~5.0V

### 6.2 RECOMMENDED OPERATING RATINGS

Parameter	Symbol	Value			Unit	Note
		Min.	Typ.	Max.		
Converter Input power supply voltage	LED_Vccs	7.0	12.0	21.0	V	
EN Control Level	Backlight On	1.6	---	5.0	V	
	Backlight Off	0	---	0.8	V	
PWM Control Level	PWM High Level	1.3	---	5.0	V	
	PWM Low Level	0	---	0.15	V	
PWM Control Duty Ratio		(2)		(100)	%	
PWM Control Permissive Ripple Voltage	V <sub>PWM_pp</sub>			100	mV	
PWM Control Frequency	f <sub>PWM</sub>	(200)	(210)	(500)	Hz	
Converter Input Current	LED_VCCS=Min	(434)	(516)	(612)	mA	(1)
	LED_VCCS=Typ	(253)	(301)	(357)	mA	(1)
	LED_VCCS=Max	(145)	(172)	(204)	mA	(1)

Note (1) The specified LED power supply current is under the conditions at "LED\_VCCS = Min/Typ/Max",  
 $T_a = 25 \pm 2 \text{ }^\circ\text{C}$ ,  $f_{\text{PWM}} = 200 \text{ Hz}$ , Duty=100%.

### 6.3 LED BACKLIGHT CONTROLL POWER SEQUENCE

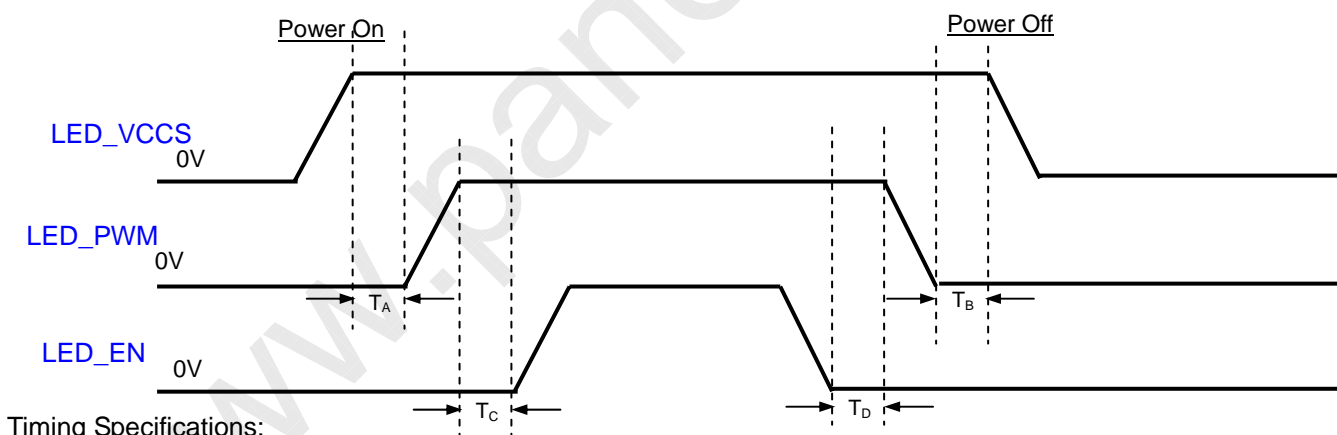

Timing Specifications:

- $T_A$  (0ms)
- $T_B$  (0ms)
- $T_C$  (10ms)
- $T_D$  (0ms)

Note (1) Please follow the LED backlight power sequence as above. If the customer could not follow, it might cause backlight flash issue during display ON/OFF or damage the LED backlight controller

## 7 INTERFACE TIMING

### 7.1 INPUT SIGNAL TIMING SPECIFICATIONS

The specifications of input signal timing are as the following table and timing diagram.

Signal	Item	Symbol	Min.	Typ.	Max.	Unit	Note
DCLK	Frequency	1/Tc	62.34	69.29	72.75	MHz	-
DE	Vertical Total Time	TV	803	822	826	TH	-
	Vertical Active Display Period	TVD	800	800	800	TH	-
	Vertical Active Blanking Period	TVB	TV-TVD	22	TV-TVD	TH	-
	Horizontal Total Time	TH	1294	1405	1468	Tc	-
	Horizontal Active Display Period	THD	1280	1280	1280	Tc	-
	Horizontal Active Blanking Period	THB	TH-THD	125	TH-THD	Tc	-

Note (1) Because this module is operated by DE only mode, Hsync and Vsync are ignored.

#### INPUT SIGNAL TIMING DIAGRAM

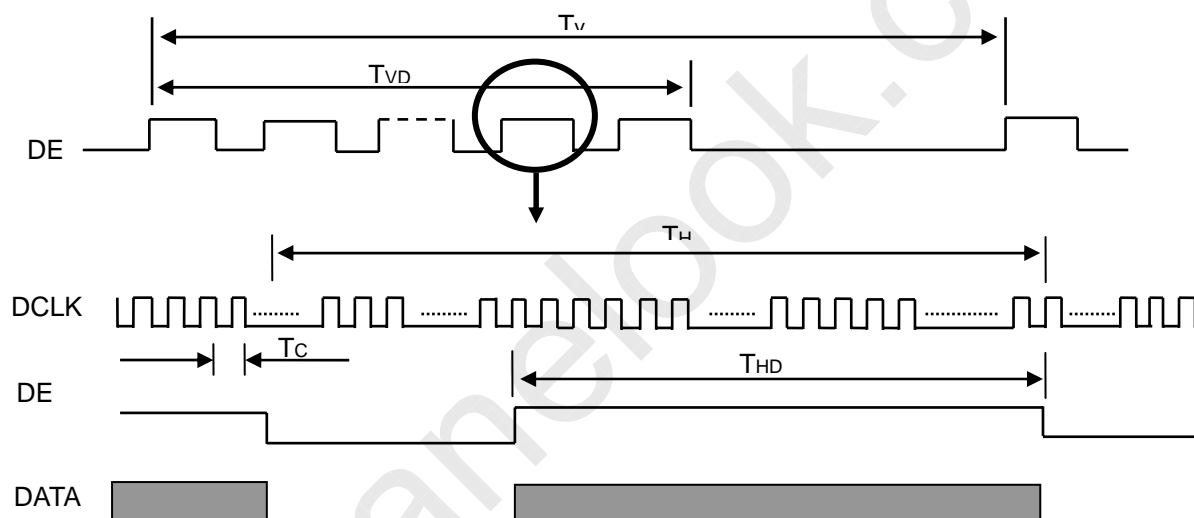

## 7.2 POWER ON/OFF SEQUENCE

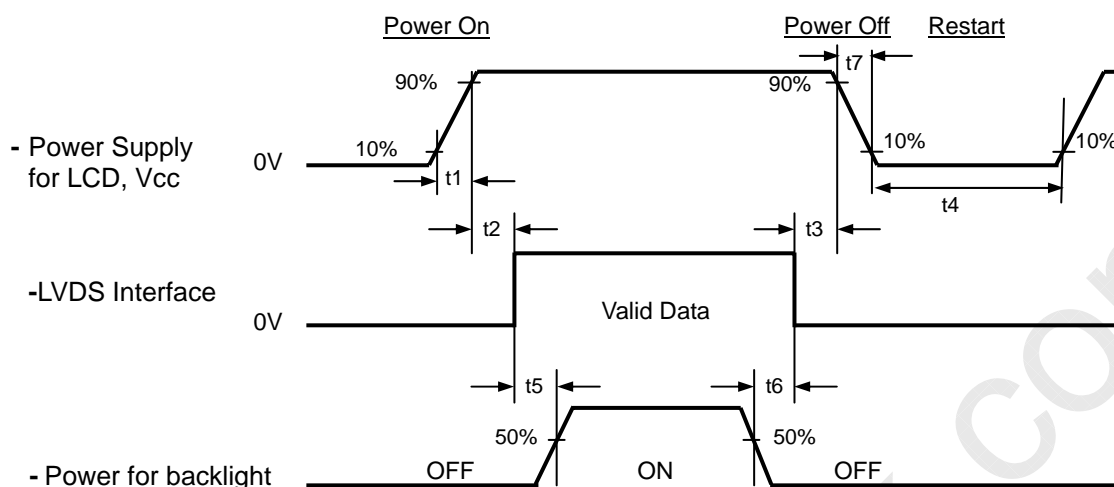

### Timing Specifications:

0.5	t1	10 ms
0	t2	50 ms
0	t3	50 ms
	t4	500 ms
	t5	200 ms
	t6	200 ms

Note (1) Please follow the power on/off sequence described above. Otherwise, the LCD module might be damaged.

Note (2) Please avoid floating state of interface signal at invalid period. When the interface signal is invalid, be sure to pull down the power supply of LCD Vcc to 0 V.

Note (3) The Backlight converter power must be turned on after the power supply for the logic and the interface signal is valid. The Backlight converter power must be turned off before the power supply for the logic and the interface signal is invalid.

Note (4) Sometimes some slight noise shows when LCD is turned off (even backlight is already off). To avoid this phenomenon, we suggest that the Vcc falling time is better to follow (50us) t7 10 ms.

## 8 OPTICAL CHARACTERISTICS

### 8.1 TEST CONDITIONS

Item	Symbol	Value	Unit
Ambient Temperature	Ta	25±2	°C
Ambient Humidity	Ha	50±10	%RH
Supply Voltage	V <sub>CC</sub>	3.3	V
Input Signal	According to typical value in "3. ELECTRICAL CHARACTERISTICS"		
LED Light Bar Input Current	I <sub>o</sub>	120	mA

The relative measurement methods of optical characteristics are shown in 8.2. The following items should be measured under the test conditions described in 8.1 and stable environment shown in Note (6).

### 8.2 OPTICAL SPECIFICATIONS

Item		Symbol	Condition	Min.	Typ.	Max.	Unit	Note	
Contrast Ratio		CR	$\theta_x=0^\circ, \theta_y=0^\circ$ Viewing Normal Angle	400	500	-	-	(2), (6)	
Response Time		T <sub>R</sub>		-	3	8	ms	(3)	
		T <sub>F</sub>		-	7	12	ms		
Average Luminance of White		L <sub>Ave</sub>		190	220	-	cd/m <sup>2</sup>	(4), (6)	
White Variation		$\delta W$		5pts	80			%	(5),(6)
				13pts	60				
Color Chromaticity	Red	Rx		CR≥10	Typ -0.03	0.580	Typ. +0.03	-	(1), (6)
		Ry				0.349		-	
	Green	Gx				0.336		-	
		Gy				0.569		-	
	Blue	Bx	0.157			-			
		By	0.135			-			
	White	Wx	0.313			-			
		Wy	0.329			-			
Viewing Angle	Horizontal	$\theta_{x+}$	40	45	-	Deg.			
		$\theta_{x-}$	40	45	-				
	Vertical	$\theta_{y+}$	15	20	-				
		$\theta_{y-}$	40	45	-				

Note (1) Definition of Viewing Angle ( $\theta_x$ ,  $\theta_y$ ):

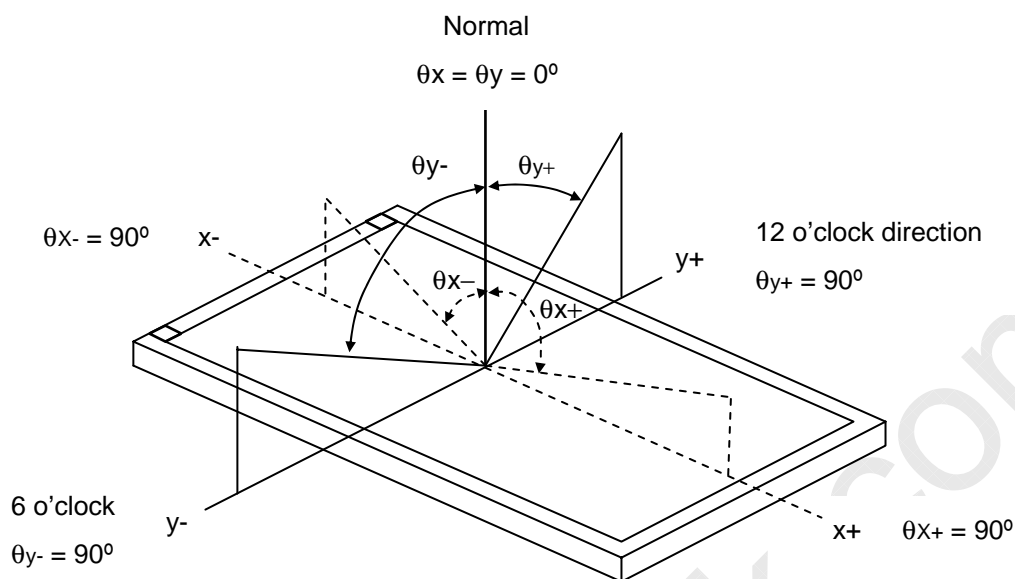

Note (2) Definition of Contrast Ratio (CR):

The contrast ratio can be calculated by the following expression.

$$\text{Contrast Ratio (CR)} = L_{63} / L_0$$

L63: Luminance of gray level 63

L 0: Luminance of gray level 0

$$\text{CR} = \text{CR} (1)$$

CR (X) is corresponding to the Contrast Ratio of the point X at Figure in Note (5).

Note (3) Definition of Response Time ( $T_R$ ,  $T_F$ ):

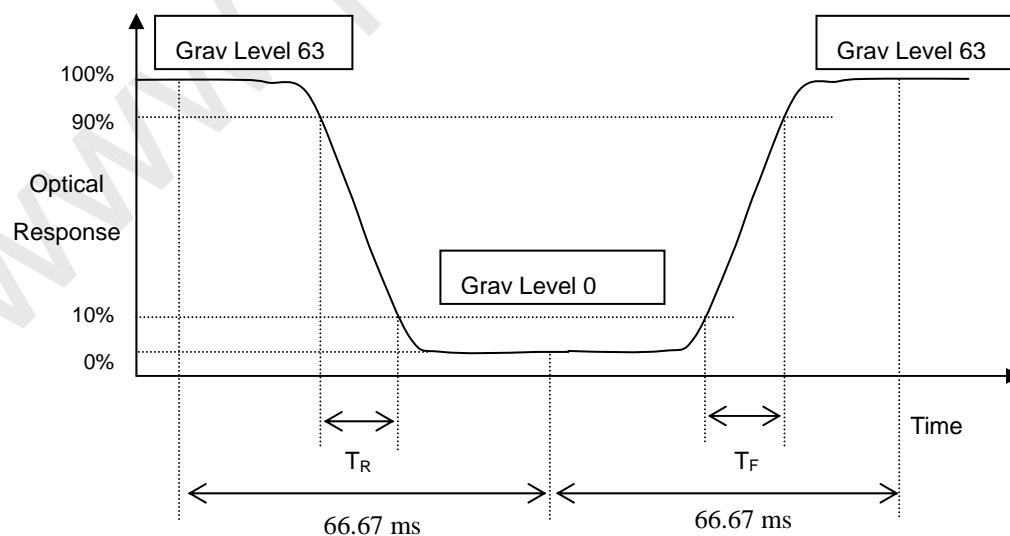

Note (4) Definition of Average Luminance of White ( $L_{AVE}$ ):

Measure the luminance of gray level 63 at 5 points

$$L_{AVE} = [L(1) + L(2) + L(3) + L(4) + L(5)] / 5$$

L(x) is corresponding to the luminance of the point X at Figure in Note (5)

Note (5) Definition of White Variation ( $\delta W$ ):

Measure the luminance of gray level 63 at 5 & 13 points

$$\delta W (5pt) = \text{Minimum} [L(1), L(2), L(3), L(4), L(5)] / \text{Maximum} [L(1), L(2), L(3), L(4), L(5)]$$

$$\delta W (13pt) = \text{Minimum} [L(1), L(2), L(3), L(4), L(5), L(6), L(7), L(8), L(9), L(10), L(11), L(12), L(13)]$$

$$/ \text{Maximum} [L(1), L(2), L(3), L(4), L(5), L(6), L(7), L(8), L(9), L(10), L(11), L(12), L(13)]$$

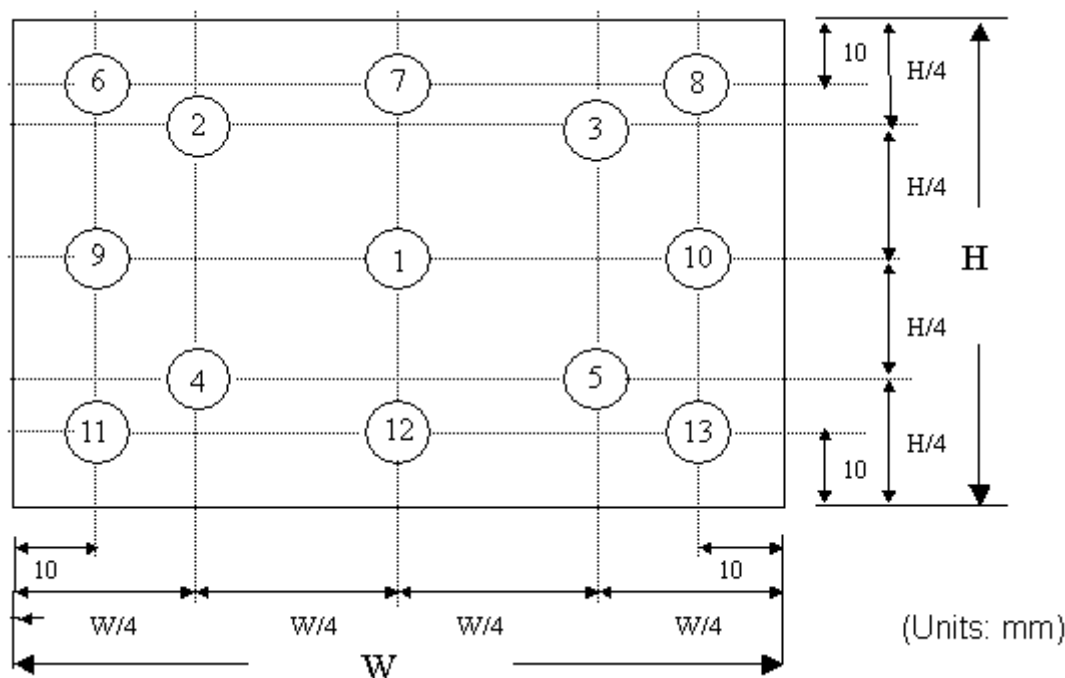

**Note (6) Measurement Setup:**

The LCD module should be stabilized at given temperature for 20 minutes to avoid abrupt temperature change during measuring. In order to stabilize the luminance, the measurement should be executed after lighting Backlight for 20 minutes in a windless room.

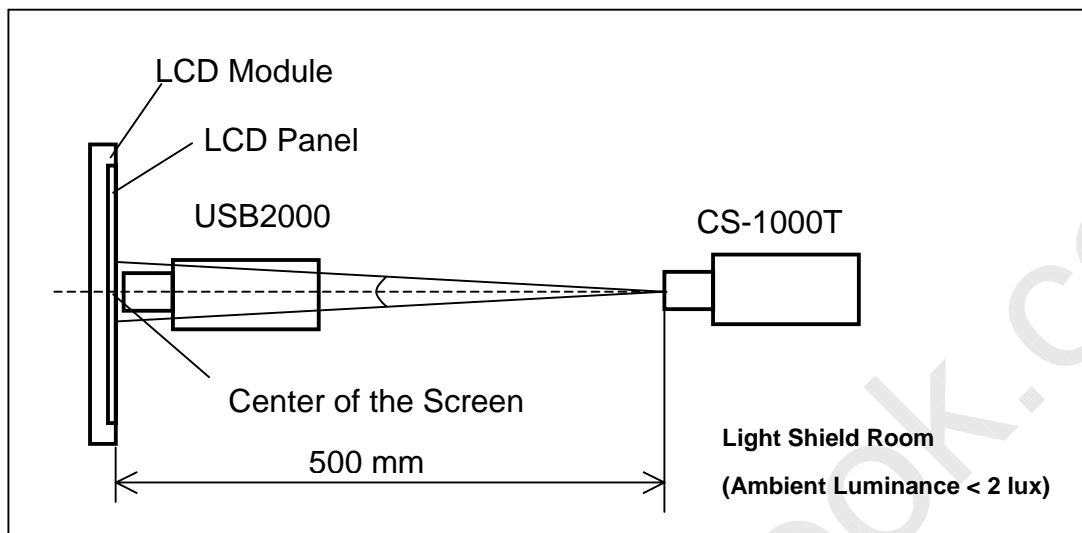

## 9 PRECAUTIONS

### 9.1 HANDLING PRECAUTIONS

- (1) The module should be assembled into the system firmly by using every mounting hole. Be careful not to twist or bend the module.
- (2) While assembling or installing modules, it can only be in the clean area. The dust and oil may cause electrical short or damage the polarizer.
- (3) Use fingerstalls or soft gloves in order to keep display clean during the incoming inspection and assembly process.
- (4) Do not press or scratch the surface harder than a HB pencil lead on the panel because the polarizer is very soft and easily scratched.
- (5) If the surface of the polarizer is dirty, please clean it by some absorbent cotton or soft cloth. Do not use Ketone type materials (ex. Acetone), Ethyl alcohol, Toluene, Ethyl acid or Methyl chloride. It might permanently damage the polarizer due to chemical reaction.
- (6) Wipe off water droplets or oil immediately. Staining and discoloration may occur if they left on panel for a long time.
- (7) If the liquid crystal material leaks from the panel, it should be kept away from the eyes or mouth. In case of contacting with hands, legs or clothes, it must be washed away thoroughly with soap.
- (8) Protect the module from static electricity, it may cause damage to the C-MOS Gate Array IC.
- (9) Do not disassemble the module.
- (10) Do not pull or fold the lamp wire.
- (11) Pins of I/F connector should not be touched directly with bare hands.

### 9.2 STORAGE PRECAUTIONS

- (1) High temperature or humidity may reduce the performance of module. Please store LCD module within the specified storage conditions.
- (2) It is dangerous that moisture come into or contacted the LCD module, because the moisture may damage LCD module when it is operating.
- (3) It may reduce the display quality if the ambient temperature is lower than 10 °C. For example, the response time will become slowly, and the starting voltage of lamp will be higher than the room temperature.





### 9.3 OPERATION PRECAUTIONS

- (1) Do not pull the I/F connector in or out while the module is operating.
- (2) Always follow the correct power on/off sequence when LCD module is connecting and operating. This can prevent the CMOS LSI chips from damage during latch-up.
- (3) The startup voltage of Backlight is approximately 1000 Volts. It may cause electrical shock while assembling with converter. Do not disassemble the module or insert anything into the Backlight unit.

### 9.4 OTHERS PRECAUTIONS

- (1) When fixed patterns are displayed for a long time, remnant image is likely to occur.

### 9.5 SAFETY STANDARDS

The LCD module should be certified with safety regulations as follows:

- (1) UL60950-1 or updated standard.
- (2) IEC60950-1 or updated standard.
- (3) UL60065 or updated standard.
- (4) IEC60065 or updated standard.

10 PACKAGING

10.1 CARTON

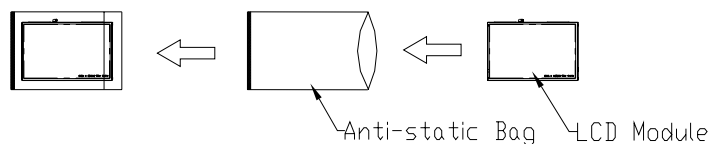

Box Dimesions: 500(L)\*400(W)\*330(H)  
Weight: Approx. 10.8kg(20 module .per. 1box)

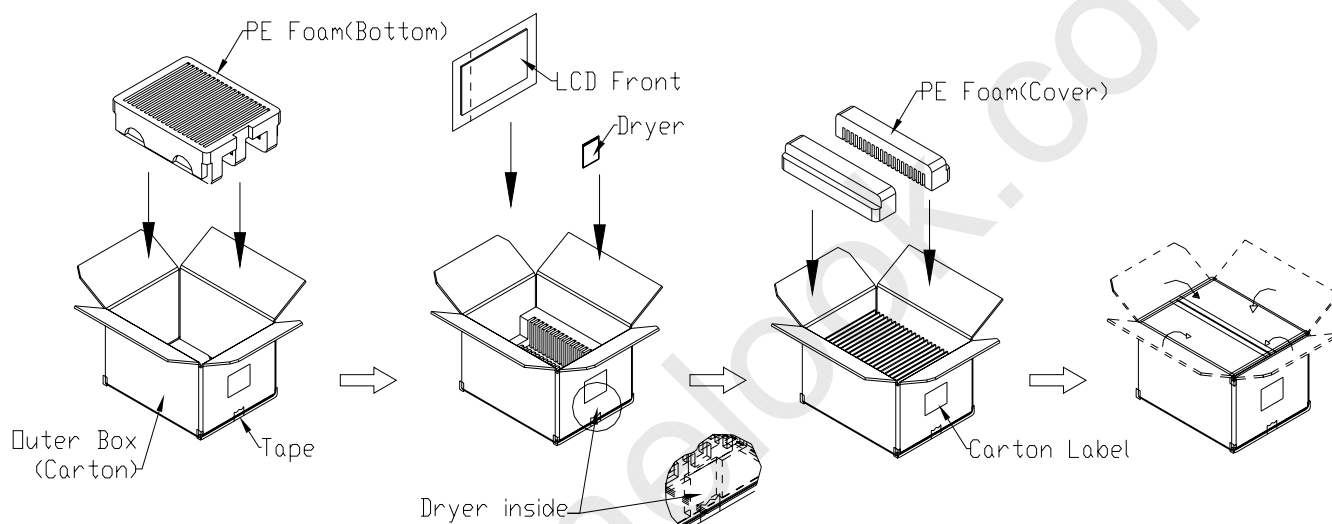
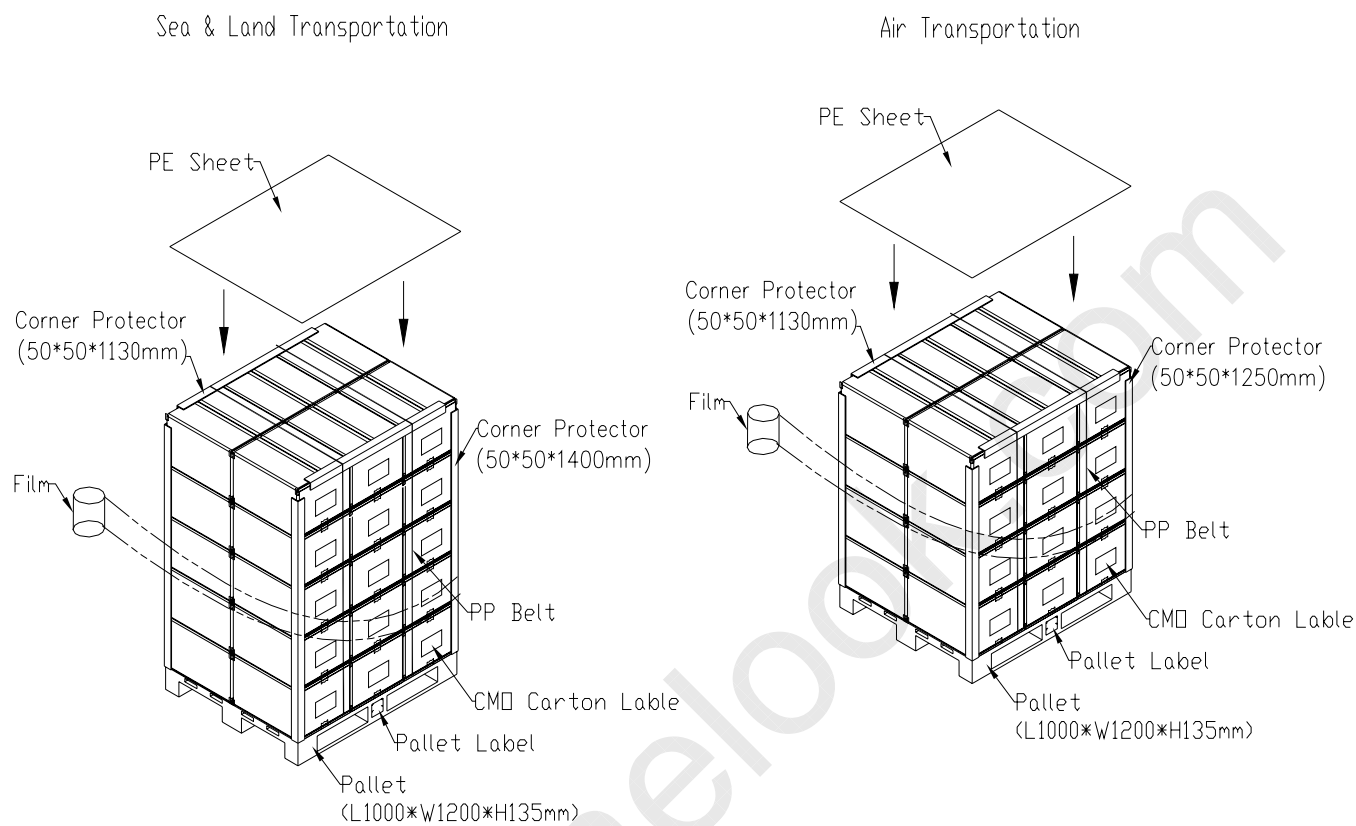

Figure. 10-1 Packing method

## 10.2 Pallet

**Figure. 10-2 Packing method**

11 DEFINITION OF LABELS

11.1 CMO MODULE LABEL

The barcode nameplate is pasted on each module as illustration, and its definitions are as following explanation.



- (a) Model Name: N141I6 - L03
- (b) Revision: Rev. XX, for example: A1, ..., C1, C2 ...etc.
- (c) Serial ID: XXXXXXYMDXNNNN

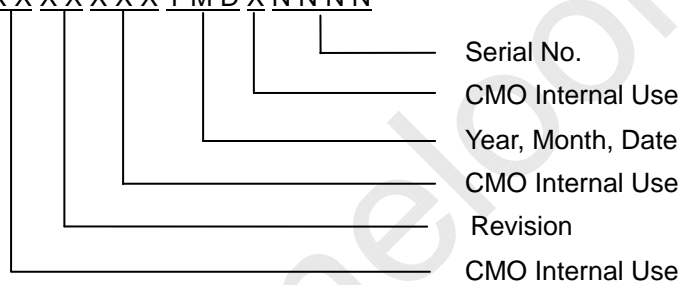

- (d) Production Location: XXXX would be Taiwan or China.
- (e)LEOO is for CMO NingBo satisfying UL requirement.

Serial ID includes the information as below:

- (a) Manufactured Date: Year: 1~9, for 2001~2009  
Month: 1~9, A~C, for Jan. ~ Dec.  
Day: 1~9, A~Y, for 1<sup>st</sup> to 31<sup>st</sup>, exclude I , O and U
- (b) Revision Code: cover all the change
- (c) Serial No.: Manufacturing sequence of product

For Lenovo's barcode content

11S42T0720Z1ZFY3SSSSSS

- (a) 11S: Fixed characters.
- (b) PPPPPPP (P/N): 42T0720
- (c) Z1Z: Fixed characters.
- (d) HHH (Header Code): 1ZFY3
- (e) SSSSSS: Series number.
- (f) YMM: Y: The last character of year. MM: Month

## 11.2 CMO CARTON LABEL

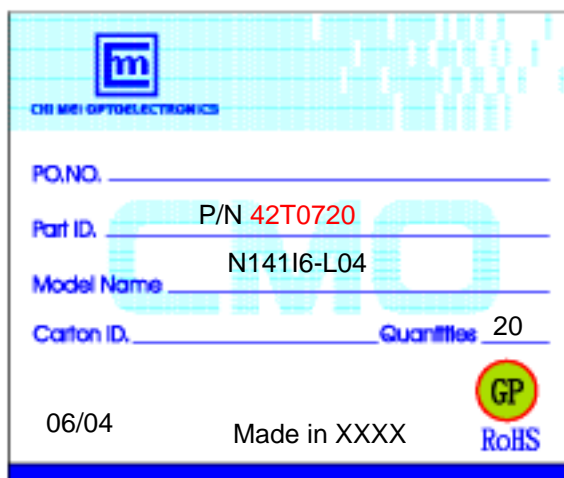

The image shows a CMO carton label with a blue and white background. At the top left is the CHI MEI logo. Below it, the text 'CHI MEI OPTOELECTRONICS' is visible. The label contains the following information: PO.NO. (blank), Part ID: P/N 42T0720, Model Name: N14116-L04, Carton ID. (blank), and Quantities: 20. At the bottom left, the date '06/04' is printed. In the center, it says 'Made in XXXX'. On the right, there is a circular 'GP' logo and the text 'RoHS' below it.

## Carton Label Explanation

- (1) Part ID: 42T0720
- (2) Model Name: CMO's Project Name.
- (3) YY/MM: Manufacturing Year and Month: (YY: The last two character of Year and MM: Month)
- (4) Production Location: Made in XXXX.

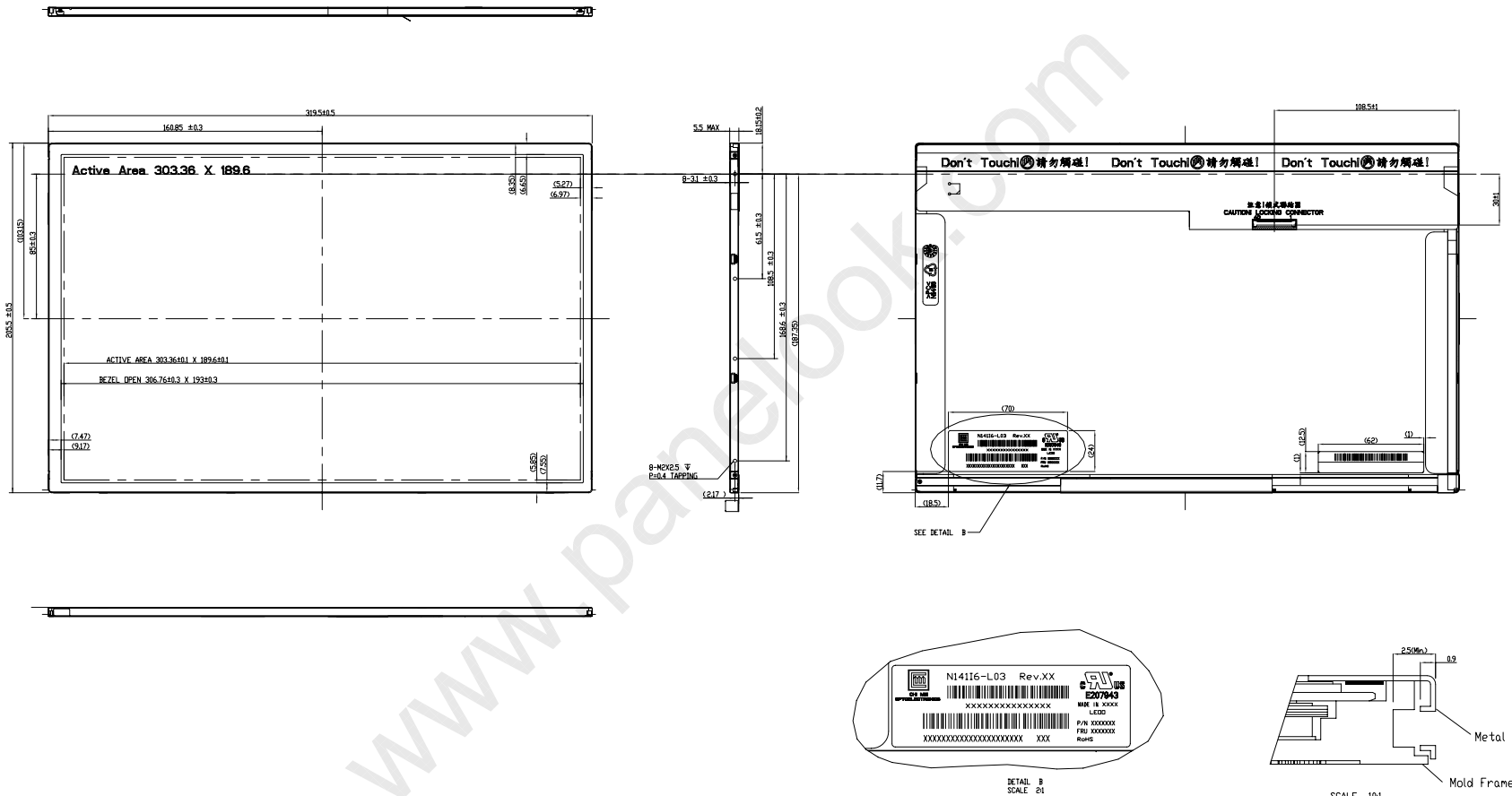

NOTES:  
 1.GENERAL TOLERANCE:±0.5mm.  
 2.ACCEPTABLE MAX. SCREW TORQUE: 2.5 kgf-cm.  
 3.SCREW HOLE DEPTH: MIN. 2.5mm.  
 4.LCD MODULE INPUT CONNECTOR: I-PEX 20455-040E-12 OR EQUIVALENT

Mark	Description	Date	Changed_By	Approved_By	ECN No.	Remark

TITLE	OUTLINE DRAWING N1416-L03	REV. 01
Approved	WILL SHEU	Drawing No. N1416-L03
Checked	CHINESE WU	Part No. NA
Drawn	CHINESE CHANG	Material: NA
Designer	HALLER KE	Date: 19-Feb-2010 Scale: 1:1
CHI MEI ELECTRONICS CORP.	ALL RIGHTS RESERVED. COPYING FORBIDDEN.	