

## TFT LCD Preliminary Specification

# MODEL NO.: N141X7 -L03

Customer : \_\_\_\_\_

Approved by : \_\_\_\_\_

Note :

| Liquid Crystal Display Division  |  |  |
|--|--|--|
| QRA Dept.  | PDD II Dept.   | PD Dept.   |
| Approval   | Approval   | Approval   |
| <br>陳<br>91.11.14<br>永一 | <br>章<br>91.11.13<br>忠光 | <br>林<br>91.11.12<br>添仁 |

**- CONTENTS -**

|   |       |    |
|---|-------|----|
| REVISION HISTORY                        | ----- | 3  |
| 1. GENERAL DESCRIPTION                  | ----- | 4  |
| 1.1 OVERVIEW                            |       |    |
| 1.2 FEATURES                            |       |    |
| 1.3 APPLICATION                         |       |    |
| 1.4 GENERAL SPECIFICATIONS              |       |    |
| 1.5 MECHANICAL SPECIFICATIONS           |       |    |
| 2. ABSOLUTE MAXIMUM RATINGS             | ----- | 5  |
| 2.1 ABSOLUTE RATINGS OF ENVIRONMENT     |       |    |
| 2.2 ELECTRICAL ABSOLUTE RATINGS         |       |    |
| 2.2.1 TFT LCD MODULE                    |       |    |
| 2.2.2 BACKLIGHT UNIT                    |       |    |
| 3. ELECTRICAL CHARACTERISTICS           | ----- | 7  |
| 3.1 TFT LCD MODULE                      |       |    |
| 3.2 BACKLIGHT UNIT                      |       |    |
| 4. BLOCK DIAGRAM                        | ----- | 10 |
| 4.1 TFT LCD MODULE                      |       |    |
| 4.2 BACKLIGHT UNIT                      |       |    |
| 5. INPUT TERMINAL PIN ASSIGNMENT        | ----- | 11 |
| 5.1 TFT LCD MODULE                      |       |    |
| 5.2 BACKLIGHT UNIT                      |       |    |
| 5.3 TIMING DIAGRAM OF LVDS INPUT SIGNAL |       |    |
| 5.4 COLOR DATA INPUT ASSIGNMENT         |       |    |
| 5.5 EDID DATA STRUCTURE                 |       |    |
| 5.6 EDID SIGNAL SPECIFICATION           |       |    |
| 6. INTERFACE TIMING                     | ----- | 18 |
| 6.1 INPUT SIGNAL TIMING SPECIFICATIONS  |       |    |
| 6.2 POWER ON/OFF SEQUENCE               |       |    |
| 7. OPTICAL CHARACTERISTICS              | ----- | 20 |
| 7.1 TEST CONDITIONS                     |       |    |
| 7.2 OPTICAL SPECIFICATIONS              |       |    |
| 8. PRECAUTIONS                          | ----- | 24 |
| 8.1 HANDLING PRECAUTIONS                |       |    |
| 8.2 STORAGE PRECAUTIONS                 |       |    |
| 8.3 OPERATION PRECAUTIONS               |       |    |
| 9. PACKING                              | ----- | 25 |
| 9.1 CARTON                              |       |    |
| 9.2 PALLET                              |       |    |
| 10. DEFINITION OF LABELS                | ----- | 27 |
| 10.1 CMO MODULE LABEL                   |       |    |
| 10.2 CARTON LABEL                       |       |    |

**REVISION HISTORY**

| Version | Date         | Page (New) | Section | Description   |
|---------|--------------|------------|---------|---|
| Ver 0.0 | Aug. 30,'02  | All        | All     | Tentative specification first issued.   |
| Ver 0.1 | Sep. 30.'02  | 21         | 7.2     | Modify contrast ratio (typ) from (200) to (250)   |
|         |              | 21         | 7.2     | Modify average luminance of white from (160) to (170)   |
| Ver 1.0 | Nov. 06. '02 | 07         | 3.1     | Power Supply Current White Icc : TBD(Typ.)→300(Typ.)<br>Power Supply Current Black Icc : TBD(Typ.)→350(Typ.)<br>Power Supply Current Vertical Stripe Icc : TBD(Typ.)→350(Typ.)  |
|         |              | 08         | 3.2     | Lamp Input Voltage VL : 562.5(Min.)/625(Typ.)/687.5(Max.)<br>→576(Min.)/640(Typ.)/704(Max.)<br>Lamp Turn On Voltage Vs : 970(25°C)/1200(0°C)→1110(25°C)/1450(0°C)<br>Power Consumption PL : 4.06(Typ.)→4.16(Typ.)   |
|         |              | 19         | 6.1     | Clock Frequency 1/Tc : TBD(Min.)→40(Min.)<br>Vsync Frequency Frequency Vsync : TBD(Typ.)/70(Max.)<br>→ 60(Typ.)/TBD(Max.)<br>Hsync Frequency Frequency Hsync : TBD(Typ.)/56(Max.)<br>→ 48(Typ.)/TBD(Max.)<br>Frame Frequency Cycle Tv : 770(Min.)/806(Typ.)/1000(Max.)<br>Vertical Active Display Term Display Period Tvd : 706(Typ.)<br>One Line Scanning Time Cycle Th : 1180(Min.)/1344(Typ.)/2000(Max.)<br>Horizontal Active Display Term Display Period Thd : 1024(Typ.)   |
|         |              | 21         | 7.2     | Contrast Ratio CR : TBD(Min.)→(200)(Min.)<br>Average Luminance White LAve : TBD(Min.)→(140)(Min.)<br>Color Chromaticity Red Rx : (0.537)(Min.)/(0.577)(Typ.)/(0.617)(Max.)<br>Color Chromaticity Red Ry : (0.308)(Min.)/(0.338)(Typ.)/(0.368)(Max.)<br>Color Chromaticity Green Gx : (0.280)(Min.)/(0.310)(Typ.)/(0.340)(Max.)<br>Color Chromaticity Green Gy : (0.524)(Min.)/(0.554)(Typ.)/(0.584)(Max.)<br>Color Chromaticity Blue Bx : (0.128)(Min.)/(0.158)(Typ.)/(0.188)(Max.)<br>Color Chromaticity Blue By : (0.084)(Min.)/(0.124)(Typ.)/(0.164)(Max.)<br>Color Chromaticity Color Gamut C.G% : TBD(Typ.)→45(Typ.) |

## 1. GENERAL DESCRIPTION

### 1.1 OVERVIEW

N141X7 -L03 is a 14.1" TFT Liquid Crystal Display module with single CCFL Backlight unit and 30 pins LVDS interface. This module supports 1024 x 768 XGA mode and can display 262,144 colors. The optimum viewing angle is at 6 o'clock direction. The inverter module for Backlight is not built in.

### 1.2 FEATURES

- Thin and light weight
- XGA (1024 x 768 pixels) resolution
- DE (Data Enable) only mode
- 3.3V LVDS (Low Voltage Differential Signaling) interface with 1 pixel/clock
- SPWG (Standard Panel Working Group) Style B compatible

### 1.3 APPLICATION

- TFT LCD Notebook

### 1.4 GENERAL SPECIFICATIONS

| Item               | Specification                           | Unit  | Note |
|--------------------|---|-------|------|
| Active Area        | 285.7 (H) x 214.3 (V) (14.1" diagonal)  | mm    | (1)  |
| Bezel Opening Area | 288.7 (H) x 217.55 (V)                  | mm    |      |
| Driver Element     | a-si TFT active matrix                  | -     | -    |
| Pixel Number       | 1024 x R.G.B. x 768                     | pixel | -    |
| Pixel Pitch        | 0.279 (H) x 0.279 (V)                   | mm    | -    |
| Pixel Arrangement  | RGB vertical stripe                     | -     | -    |
| Display Colors     | 262,144                                 | color | -    |
| Transmissive Mode  | Normally white                          | -     | -    |
| Surface Treatment  | Hard coating (3H), Anti-glare (Haze 25) | -     | -    |

### 1.5 MECHANICAL SPECIFICATIONS

| Item                            | Min.   | Typ.  | Max.  | Unit  | Note |     |
|---------------------------------|--|-------|-------|-------|------|-----|
| Module Size                     | Horizontal(H)  | 298.5 | 299.0 | 299.5 | mm   | (1) |
|                                 | Vertical(V)  | 226   | 226.5 | 227   | mm   |     |
|                                 | Depth(D)   | -     | 5.2   | 5.5   | mm   |     |
| Weight                          | -  | 400   | 415   | g     | -    |     |
| I/F connector mounting position | The mounting inclination of the connector makes the screen center within $\pm 0.5\text{mm}$ as the horizontal. |       |       |       | (2)  |     |

Note (1) Please refer to the attached drawings for more information of front and back outline dimensions.

(2) Connector mounting position



## 2. ABSOLUTE MAXIMUM RATINGS

### 2.1 ABSOLUTE RATINGS OF ENVIRONMENT

| Item                          | Symbol           | Value |      | Unit | Note     |
|-------------------------------|------------------|-------|------|------|----------|
|                               |                  | Min.  | Max. |      |          |
| Storage Temperature           | T <sub>ST</sub>  | -20   | +60  | °C   | (1)      |
| Operating Ambient Temperature | T <sub>OP</sub>  | 0     | +50  | °C   | (1), (2) |
| Shock (Non-Operating)         | S <sub>NOP</sub> | -     | 210  | G    | (3), (5) |
| Vibration (Non-Operating)     | V <sub>NOP</sub> | -     | 1.5  | G    | (4), (5) |

Note (1) Temperature and relative humidity range is shown in the figure below.

(a) 90 %RH Max. ( $T_a \leq 40\text{ }^\circ\text{C}$ ).

(b) Wet-bulb temperature should be 39 °C Max. ( $T_a > 40\text{ }^\circ\text{C}$ ).

(c) No condensation .

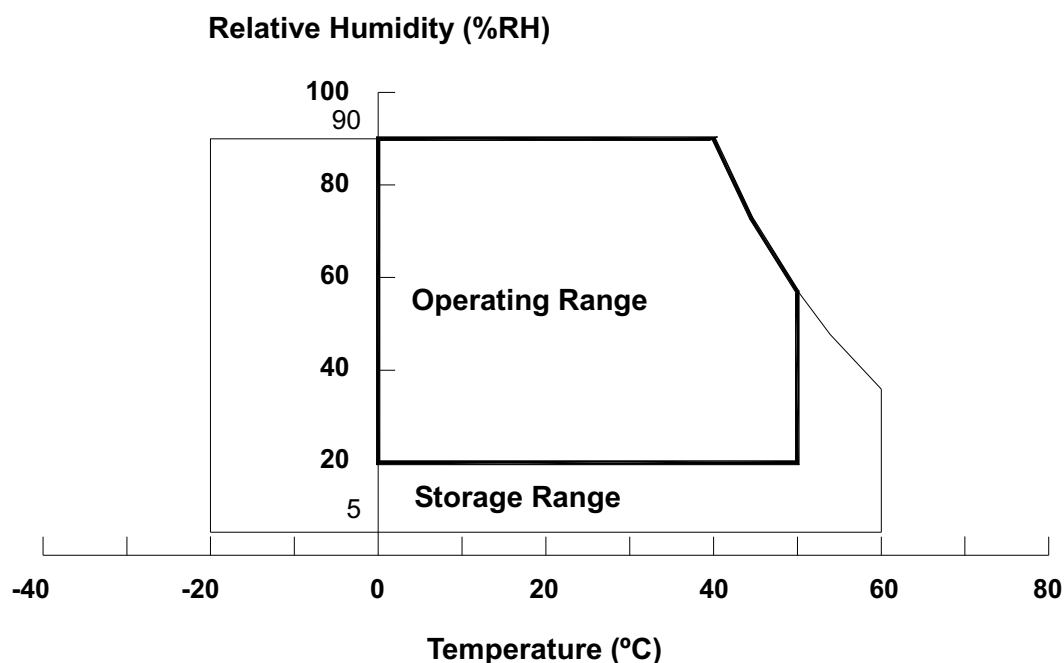

Note (2) The temperature of panel surface should be 0 °C Min. and 50 °C Max.

Note (3) 2.5ms, half sine wave, 1 time for  $\pm X$ ,  $\pm Y$ ,  $\pm Z$ .

Note (4) 10 ~ 200 Hz, 0.5 Hr / Cycle, 1 cycles for each X, Y, Z. The fixing condition is shown as below:

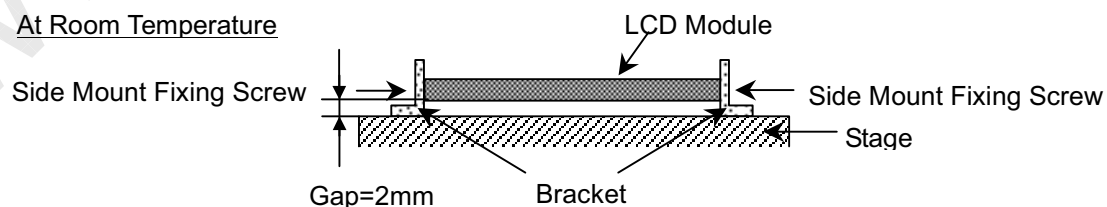

Note (5) At testing Vibration and Shock, the fixture in holding the module has to be hard and rigid enough so that the module would not be twisted or bent by the fixture.

## 2.2 ELECTRICAL ABSOLUTE RATINGS

### 2.2.1 TFT LCD MODULE

| Item                 | Symbol          | Value |                      | Unit | Note |
|----------------------|-----------------|-------|----------------------|------|------|
|                      |                 | Min.  | Max.                 |      |      |
| Power Supply Voltage | V <sub>CC</sub> | -0.3  | +4.0                 | V    | (1)  |
| Logic Input Voltage  | V <sub>IN</sub> | -0.3  | V <sub>CC</sub> +0.3 | V    |      |

### 2.2.2 BACKLIGHT UNIT

| Item           | Symbol         | Value |      | Unit              | Note                                |
|----------------|----------------|-------|------|-------------------|-------------------------------------|
|                |                | Min.  | Max. |                   |                                     |
| Lamp Voltage   | V <sub>L</sub> | -     | 2.5K | V <sub>RMS</sub>  | (1), (2), I <sub>L</sub> = (6.0) mA |
| Lamp Current   | I <sub>L</sub> | -     | 7.0  | mA <sub>RMS</sub> |                                     |
| Lamp Frequency | F <sub>L</sub> | -     | 85   | KHZ               | (1), (2)                            |

Note (1) Permanent damage to the device may occur if maximum values are exceeded. Function operation should be restricted to the conditions described under Normal Operating Conditions.

Note (2) Specified values are for lamp (Refer to Section 3.2 for further information).

### 3. ELECTRICAL CHARACTERISTICS

#### 3.1 TFT LCD MODULE

 $T_a = 25 \pm 2 \text{ }^\circ\text{C}$ 

| Parameter  | Symbol          | Value    |      |      | Unit | Note |
|--|-----------------|----------|------|------|------|------|
|  |                 | Min.     | Typ. | Max. |      |      |
| Power Supply Voltage                                   | $V_{CC}$        | 3.0      | 3.3  | 3.6  | V    | -    |
| Ripple Voltage   | $V_{RP}$        | -        | -    | 100  | mV   | -    |
| Rush Current   | $I_{RUSH}$      | -        | -    | 1.5  | A    | (2)  |
| Power Supply Current                                   | White           | -        | 300  | -    | mA   | (3)a |
|  | Black           | -        | 350  | -    | mA   | (3)b |
|  | Vertical Stripe | -        | 350  | -    | mA   | (3)c |
| Differential Input Voltage for LVDS Receiver Threshold | "H" Level       | $V_{IH}$ | -    | +100 | mV   | -    |
|  | "L" Level       | $V_{IL}$ | -100 | -    | mV   | -    |
| Terminating Resistor                                   | $R_T$           | -        | 100  | -    | Ohm  | -    |

Note (1) The module should be always operated within above ranges.

Note (2) Measurement Conditions:

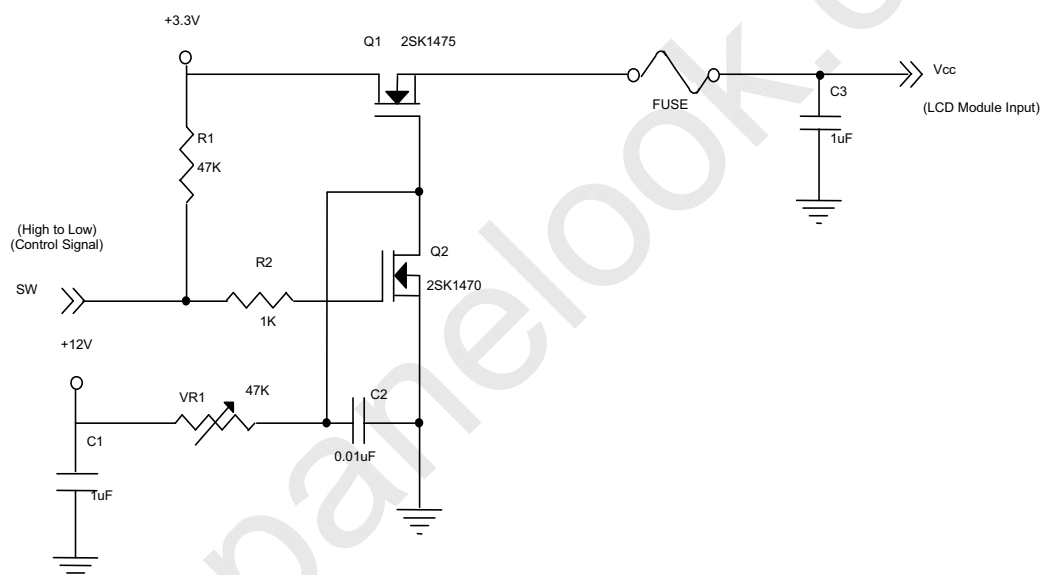

**Vcc rising time is 470us**

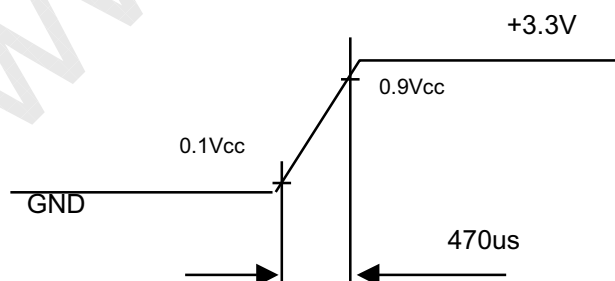

Note (3) The specified power supply current is under the conditions at  $V_{CC} = 3.3\text{ V}$ ,  $T_a = 25 \pm 2\text{ }^\circ\text{C}$ , DC Current and  $f_v = 60\text{ Hz}$ , whereas a power dissipation check pattern below is displayed.

a. White Pattern



Active Area

b. Black Pattern

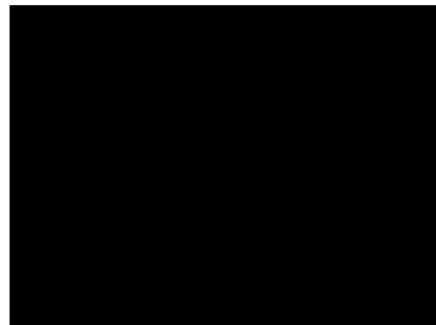

Active Area

c. Vertical Stripe Pattern

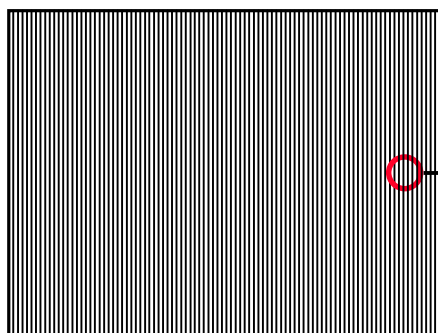

Active Area

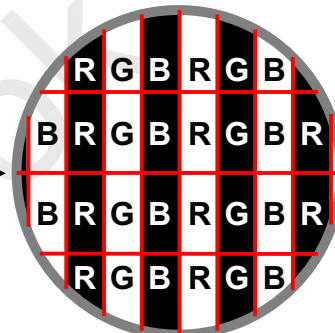

### 3.2 BACKLIGHT UNIT

 $T_a = 25 \pm 2\text{ }^\circ\text{C}$ 

| Parameter            | Symbol   | Value  |      |              | Unit       | Note                       |
|----------------------|----------|--------|------|--------------|------------|----------------------------|
|                      |          | Min.   | Typ. | Max.         |            |                            |
| Lamp Input Voltage   | $V_L$    | 576    | 640  | 704          | $V_{RMS}$  | $I_L = 6.5\text{ mA}$      |
| Lamp Current         | $I_L$    | 2.0    | 6.5  | 7.0          | $mA_{RMS}$ | (1)                        |
| Lamp Turn On Voltage | $V_s$    | -      | -    | 1110 (25 °C) | $V_{RMS}$  | (2)                        |
|                      |          | -      | -    | 1450 (0 °C)  | $V_{RMS}$  | (2)                        |
| Operating Frequency  | $F_L$    | 40     | -    | 80           | KHz        | (3)                        |
| Lamp Life Time       | $L_{BL}$ | 10,000 | -    | -            | Hrs        | (5)                        |
| Power Consumption    | $P_L$    | -      | 4.16 | -            | W          | (4), $I_L = 6.5\text{ mA}$ |

Note (1) Lamp current is measured by utilizing a high frequency current meter as shown below:

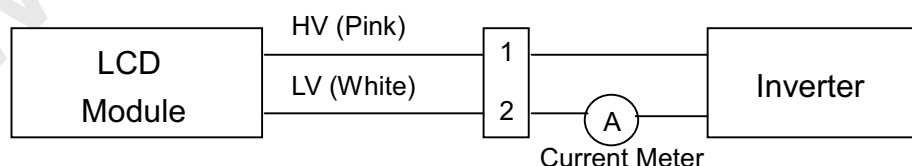

Note (2) The voltage shown above should be applied to the lamp for more than 1 second after startup. Otherwise the lamp may not be turned on.



Note (3) The lamp frequency may generate interference with horizontal synchronous frequency from the display, and this may cause line flow on the display. In order to avoid interference, the lamp frequency should be detached from the horizontal synchronous frequency and its harmonics as far as possible.

Note (4)  $P_L = I_L \times V_L$

Note (5) The lifetime of lamp is defined as the time when it continues to operate under the conditions at  $T_a = 25 \pm 2 \text{ }^\circ\text{C}$  and  $I_L = 6.5 \text{ mA}_{\text{RMS}}$  until one of the following events occurs:

(a) When the brightness becomes  $\leq 50\%$  of its original value.

(b) When the effective ignition length becomes  $\leq 80\%$  of its original value. (Effective ignition length is defined as an area that the brightness is less than 70% compared to the center point.)

Note (6) The waveform of the voltage output of inverter must be area-symmetric and the design of the inverter must have specifications for the modularized lamp. The performance of the Backlight, such as lifetime or brightness, is greatly influenced by the characteristics of the DC-AC inverter for the lamp. All the parameters of an inverter should be carefully designed to avoid generating too much current leakage from high voltage output of the inverter. When designing or ordering the inverter please make sure that a poor lighting caused by the mismatch of the Backlight and the inverter (miss-lighting, flicker, etc.) never occurs. If the above situation is confirmed, the module should be operated in the same manners when it is installed in your instrument.

## 4. BLOCK DIAGRAM

### 4.1 TFT LCD MODULE

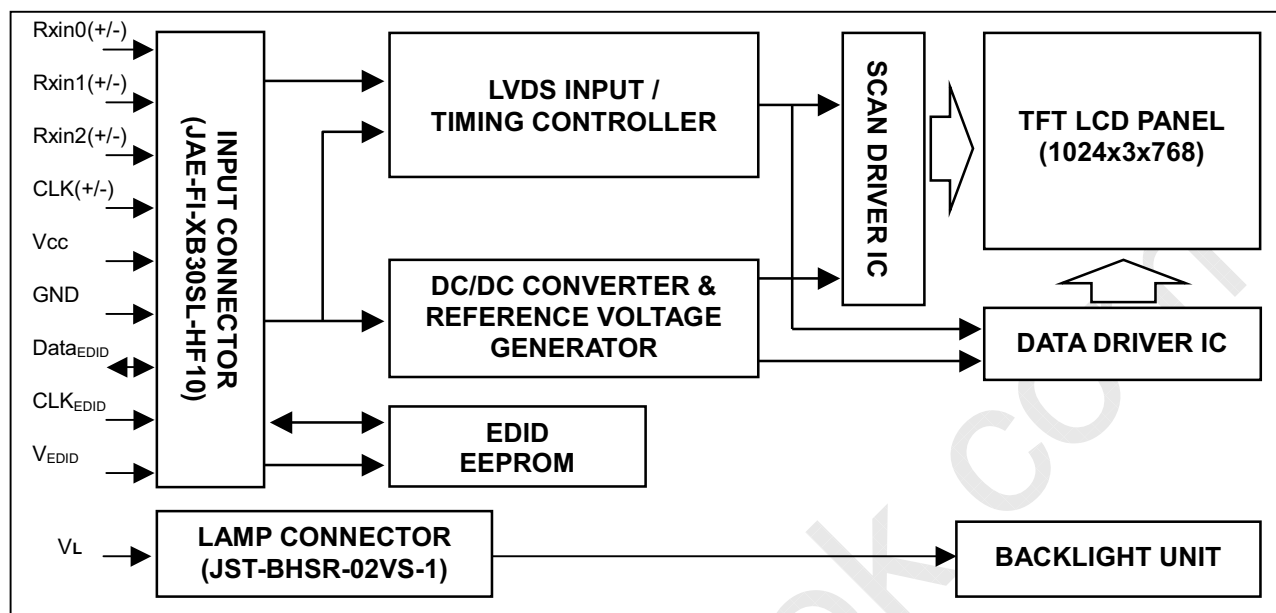

### 4.2 BACKLIGHT UNIT

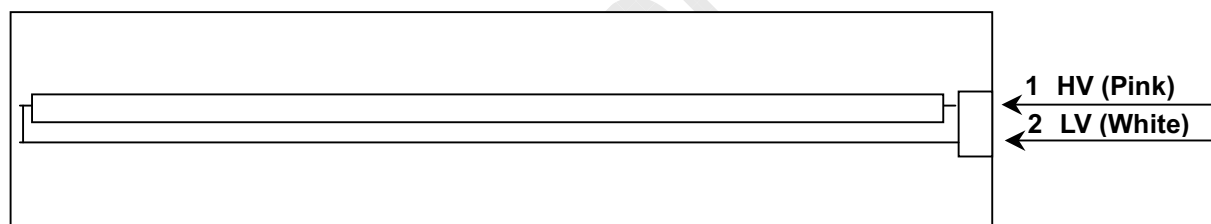

## 5. INPUT TERMINAL PIN ASSIGNMENT

### 5.1 TFT LCD MODULE

| Pin | Symbol               | Description                  | Polarity | Remark               |
|-----|----------------------|------------------------------|----------|----------------------|
| 1   | Vss                  | Ground                       |          | -                    |
| 2   | Vcc                  | Power Supply +3.3 V          |          | -                    |
| 3   | Vcc                  | Power Supply +3.3 V          |          | -                    |
| 4   | V <sub>EDID</sub>    | DDC +3.3 V                   |          |                      |
| 5   | NC                   | -                            | -        | -                    |
| 6   | CLK <sub>EDID</sub>  | DDC Clock                    |          |                      |
| 7   | Data <sub>EDID</sub> | DDC Data                     |          |                      |
| 8   | Rxin0-               | LVDS Differential Data Input | Negative | G1~G5,B0,B1          |
| 9   | Rxin0+               | LVDS Differential Data Input | Positive |                      |
| 10  | Vss                  | Ground                       |          |                      |
| 11  | Rxin1-               | LVDS Differential Data Input | Negative | B2~B5,Hsync,Vsync,DE |
| 12  | Rxin1+               | LVDS Differential Data Input | Positive |                      |
| 13  | Vss                  | Ground                       |          |                      |
| 14  | Rxin2-               | LVDS Differential Data Input | Negative | B2~B5,Hsync,Vsync,DE |
| 15  | Rxin2+               | LVDS Differential Data Input | Positive |                      |
| 16  | Vss                  | Ground                       |          |                      |
| 17  | CLK-                 | LVDS Clock Data Input        | Negative | LVDS Level           |
| 18  | CLK+                 | LVDS Clock Data Input        | Positive |                      |
| 19  | Vss                  | Ground                       |          |                      |
| 20  | NC                   | -                            | -        | -                    |
| 21  | NC                   | -                            | -        | -                    |
| 22  | NC                   | -                            | -        | -                    |
| 23  | NC                   | -                            | -        | -                    |
| 24  | NC                   | -                            | -        | -                    |
| 25  | NC                   | -                            | -        | -                    |
| 26  | NC                   | -                            | -        | -                    |
| 27  | NC                   | -                            | -        | -                    |
| 28  | NC                   | -                            | -        | -                    |
| 29  | NC                   | -                            | -        | -                    |
| 30  | NC                   | -                            | -        | -                    |

Note (1) Connector Part No.: JAE-FI-XB30SL-HF10 or equivalent

Note (2) User's connector Part No: JAE-FI-X30C2L or equivalent

## 5.2 BACKLIGHT UNIT

| Pin | Symbol | Description  | Color |
|-----|--------|--------------|-------|
| 1   | HV     | High Voltage | Pink  |
| 2   | LV     | Ground       | White |

Note (1) Connector Part No.: JST-BHSR-02VS-1 or equivalent

Note (2) User's connector Part No.: JST-SM02B-BHSS-1-TB or equivalent

## 5.3 TIMING DIAGRAM OF LVDS INPUT SIGNAL

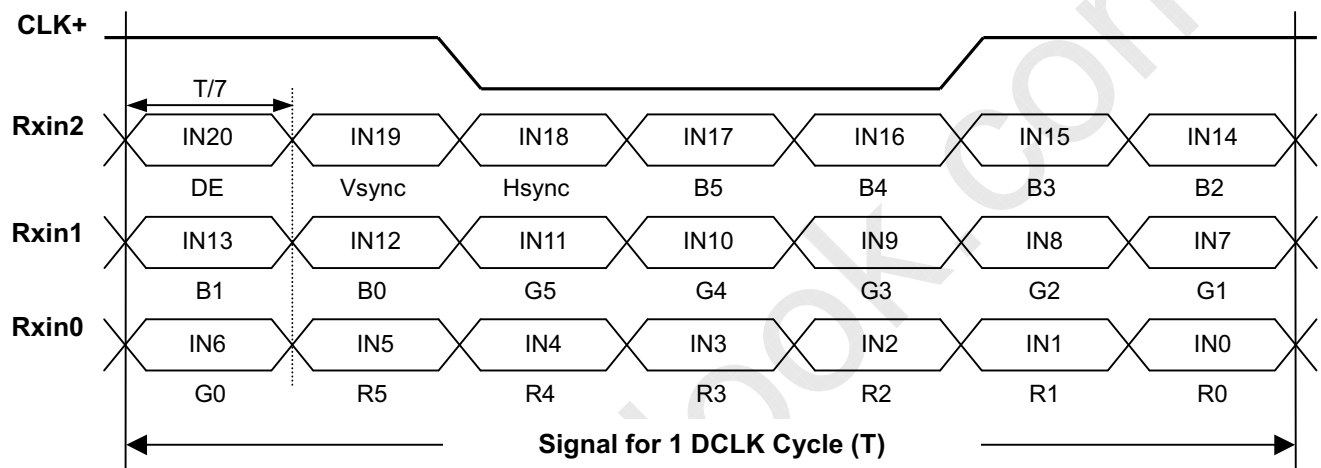

#### 5.4 COLOR DATA INPUT ASSIGNMENT

The brightness of each primary color (red, green and blue) is based on the 6-bit gray scale data input for the color. The higher the binary input the brighter the color. The table below provides the assignment of color versus data input.

| Color               |               | Data Signal |    |    |    |    |    |       |    |    |    |    |    |      |    |    |    |    |    |
|---------------------|---------------|-------------|----|----|----|----|----|-------|----|----|----|----|----|------|----|----|----|----|----|
|                     |               | Red         |    |    |    |    |    | Green |    |    |    |    |    | Blue |    |    |    |    |    |
|                     |               | R5          | R4 | R3 | R2 | R1 | R0 | G5    | G4 | G3 | G2 | G1 | G0 | B5   | B4 | B3 | B2 | B1 | B0 |
| Basic Colors        | Black         | 0           | 0  | 0  | 0  | 0  | 0  | 0     | 0  | 0  | 0  | 0  | 0  | 0    | 0  | 0  | 0  | 0  | 0  |
|                     | Red           | 1           | 1  | 1  | 1  | 1  | 1  | 0     | 0  | 0  | 0  | 0  | 0  | 0    | 0  | 0  | 0  | 0  | 0  |
|                     | Green         | 0           | 0  | 0  | 0  | 0  | 0  | 1     | 1  | 1  | 1  | 1  | 1  | 0    | 0  | 0  | 0  | 0  | 0  |
|                     | Blue          | 0           | 0  | 0  | 0  | 0  | 0  | 0     | 0  | 0  | 0  | 0  | 0  | 1    | 1  | 1  | 1  | 1  | 1  |
|                     | Cyan          | 0           | 0  | 0  | 0  | 0  | 0  | 1     | 1  | 1  | 1  | 1  | 1  | 1    | 1  | 1  | 1  | 1  | 1  |
|                     | Magenta       | 1           | 1  | 1  | 1  | 1  | 1  | 0     | 0  | 0  | 0  | 0  | 0  | 0    | 1  | 1  | 1  | 1  | 1  |
|                     | Yellow        | 1           | 1  | 1  | 1  | 1  | 1  | 1     | 1  | 1  | 1  | 1  | 1  | 0    | 0  | 0  | 0  | 0  | 0  |
|                     | White         | 1           | 1  | 1  | 1  | 1  | 1  | 1     | 1  | 1  | 1  | 1  | 1  | 1    | 1  | 1  | 1  | 1  | 1  |
| Gray Scale Of Red   | Red(0)/Dark   | 0           | 0  | 0  | 0  | 0  | 0  | 0     | 0  | 0  | 0  | 0  | 0  | 0    | 0  | 0  | 0  | 0  | 0  |
|                     | Red(1)        | 0           | 0  | 0  | 0  | 0  | 1  | 0     | 0  | 0  | 0  | 0  | 0  | 0    | 0  | 0  | 0  | 0  | 0  |
|                     | Red(2)        | 0           | 0  | 0  | 0  | 1  | 0  | 0     | 0  | 0  | 0  | 0  | 0  | 0    | 0  | 0  | 0  | 0  | 0  |
|                     | :             | :           | :  | :  | :  | :  | :  | :     | :  | :  | :  | :  | :  | :    | :  | :  | :  | :  | :  |
|                     | :             | :           | :  | :  | :  | :  | :  | :     | :  | :  | :  | :  | :  | :    | :  | :  | :  | :  | :  |
|                     | :             | :           | :  | :  | :  | :  | :  | :     | :  | :  | :  | :  | :  | :    | :  | :  | :  | :  | :  |
|                     | Red(61)       | 1           | 1  | 1  | 1  | 0  | 1  | 0     | 0  | 0  | 0  | 0  | 0  | 0    | 0  | 0  | 0  | 0  | 0  |
|                     | Red(62)       | 1           | 1  | 1  | 1  | 1  | 0  | 0     | 0  | 0  | 0  | 0  | 0  | 0    | 0  | 0  | 0  | 0  | 0  |
| Red(63)             | 1             | 1           | 1  | 1  | 1  | 1  | 0  | 0     | 0  | 0  | 0  | 0  | 0  | 0    | 0  | 0  | 0  | 0  |    |
| Gray Scale Of Green | Green(0)/Dark | 0           | 0  | 0  | 0  | 0  | 0  | 0     | 0  | 0  | 0  | 0  | 0  | 0    | 0  | 0  | 0  | 0  | 0  |
|                     | Green(1)      | 0           | 0  | 0  | 0  | 0  | 0  | 0     | 0  | 0  | 0  | 0  | 1  | 0    | 0  | 0  | 0  | 0  | 0  |
|                     | Green(2)      | 0           | 0  | 0  | 0  | 0  | 0  | 0     | 0  | 0  | 0  | 1  | 0  | 0    | 0  | 0  | 0  | 0  | 0  |
|                     | :             | :           | :  | :  | :  | :  | :  | :     | :  | :  | :  | :  | :  | :    | :  | :  | :  | :  | :  |
|                     | :             | :           | :  | :  | :  | :  | :  | :     | :  | :  | :  | :  | :  | :    | :  | :  | :  | :  | :  |
|                     | :             | :           | :  | :  | :  | :  | :  | :     | :  | :  | :  | :  | :  | :    | :  | :  | :  | :  | :  |
|                     | Green(61)     | 0           | 0  | 0  | 0  | 0  | 0  | 1     | 1  | 1  | 1  | 0  | 1  | 0    | 0  | 0  | 0  | 0  | 0  |
|                     | Green(62)     | 0           | 0  | 0  | 0  | 0  | 0  | 1     | 1  | 1  | 1  | 1  | 0  | 0    | 0  | 0  | 0  | 0  | 0  |
| Green(63)           | 0             | 0           | 0  | 0  | 0  | 0  | 1  | 1     | 1  | 1  | 1  | 1  | 0  | 0    | 0  | 0  | 0  | 0  |    |
| Gray Scale Of Blue  | Blue(0)/Dark  | 0           | 0  | 0  | 0  | 0  | 0  | 0     | 0  | 0  | 0  | 0  | 0  | 0    | 0  | 0  | 0  | 0  | 0  |
|                     | Blue(1)       | 0           | 0  | 0  | 0  | 0  | 0  | 0     | 0  | 0  | 0  | 0  | 0  | 0    | 0  | 0  | 0  | 0  | 1  |
|                     | Blue(2)       | 0           | 0  | 0  | 0  | 0  | 0  | 0     | 0  | 0  | 0  | 0  | 0  | 0    | 0  | 0  | 0  | 1  | 0  |
|                     | :             | :           | :  | :  | :  | :  | :  | :     | :  | :  | :  | :  | :  | :    | :  | :  | :  | :  | :  |
|                     | :             | :           | :  | :  | :  | :  | :  | :     | :  | :  | :  | :  | :  | :    | :  | :  | :  | :  | :  |
|                     | :             | :           | :  | :  | :  | :  | :  | :     | :  | :  | :  | :  | :  | :    | :  | :  | :  | :  | :  |
|                     | Blue(61)      | 0           | 0  | 0  | 0  | 0  | 0  | 0     | 0  | 0  | 0  | 0  | 0  | 1    | 1  | 1  | 1  | 0  | 1  |
|                     | Blue(62)      | 0           | 0  | 0  | 0  | 0  | 0  | 0     | 0  | 0  | 0  | 0  | 0  | 1    | 1  | 1  | 1  | 1  | 0  |
| Blue(63)            | 0             | 0           | 0  | 0  | 0  | 0  | 0  | 0     | 0  | 0  | 0  | 0  | 1  | 1    | 1  | 1  | 1  | 1  |    |

Note (1) 0: Low Level Voltage, 1: High Level Voltage

## 5.5 EDID DATA STRUCTURE

The EDID (Extended Display Identification Data) data formats are to support displays as defined in the VESA Plug & Display and FPD1 standards.

| Byte #<br>(decimal) | Byte #<br>(hex) | Field Name and Comments                             | Value<br>(hex) | Value<br>(binary) |
|---------------------|-----------------|---|----------------|-------------------|
| 0                   | 0               | Header  | TBD            | TBD               |
| 1                   | 1               | Header  | TBD            | TBD               |
| 2                   | 2               | Header  | TBD            | TBD               |
| 3                   | 3               | Header  | TBD            | TBD               |
| 4                   | 4               | Header  | TBD            | TBD               |
| 5                   | 5               | Header  | TBD            | TBD               |
| 6                   | 6               | Header  | TBD            | TBD               |
| 7                   | 7               | Header  | TBD            | TBD               |
| 8                   | 8               | EISA ID manufacturer name ( "TBD" )                 | TBD            | TBD               |
| 9                   | 9               | EISA ID manufacturer name (Compressed ASCII)        | TBD            | TBD               |
| 10                  | 0A              | ID product code (N141X7 = " TBD" )                  | TBD            | TBD               |
| 11                  | 0B              | ID product code (hex LSB first)                     | TBD            | TBD               |
| 12                  | 0C              | ID S/N (fixed "0" )                                 | TBD            | TBD               |
| 13                  | 0D              | ID S/N (fixed "0" )                                 | TBD            | TBD               |
| 14                  | 0E              | ID S/N (fixed "0" )                                 | TBD            | TBD               |
| 15                  | 0F              | ID S/N (fixed "0" )                                 | TBD            | TBD               |
| 16                  | 10              | Week of manufacture (fixed "TBD" )                  | TBD            | TBD               |
| 17                  | 11              | Year of manufacture (fixed "TBD" )                  | TBD            | TBD               |
| 18                  | 12              | EDID structure version # ( "1" )                    | TBD            | TBD               |
| 19                  | 13              | EDID revision # ( "3" )                             | TBD            | TBD               |
| 20                  | 14              | Video I/P definition ( "digital" )                  | TBD            | TBD               |
| 21                  | 15              | Max H image size ( "28 cm" )                        | TBD            | TBD               |
| 22                  | 16              | Max V image size ( "21 cm" )                        | TBD            | TBD               |
| 23                  | 17              | Display Gamma (Gamma = " 2.2" )                     | TBD            | TBD               |
| 24                  | 18              | Feature support ( "RGB, preferred timing" )         | TBD            | TBD               |
| 25                  | 19              | Red/Green (Rx1, Rx0, Ry1, Ry0, Gx1, Gx0, Gy1, Gy0)  | TBD            | TBD               |
| 26                  | 1A              | Blue/White (Bx1, Bx0, By1, By0, Wx1, Wx0, Wy1, Wy0) | TBD            | TBD               |
| 27                  | 1B              | Red-x (Rx = "TBD")                                  | TBD            | TBD               |
| 28                  | 1C              | Red-y (Ry = "TBD")                                  | TBD            | TBD               |
| 29                  | 1D              | Green-x (Gx = " TBD")                               | TBD            | TBD               |
| 30                  | 1E              | Green-y (Gy = " TBD")                               | TBD            | TBD               |
| 31                  | 1F              | Blue-x (Bx = " TBD")                                | TBD            | TBD               |
| 32                  | 20              | Blue-y (By = " TBD")                                | TBD            | TBD               |
| 33                  | 21              | White-x (Wx = " TBD" )                              | TBD            | TBD               |
| 34                  | 22              | White-y (Wy = " TBD" )                              | TBD            | TBD               |
| 35                  | 23              | Established timings 1                               | TBD            | TBD               |
| 36                  | 24              | Established timings 2 (1024x768@60Hz)               | TBD            | TBD               |
| 37                  | 25              | Manufacturer' s reserved timings                    | TBD            | TBD               |
| 38                  | 26              | Standard timing ID # 1                              | TBD            | TBD               |
| 39                  | 27              | Standard timing ID # 1                              | TBD            | TBD               |
| 40                  | 28              | Standard timing ID # 2                              | TBD            | TBD               |
| 41                  | 29              | Standard timing ID # 2                              | TBD            | TBD               |

| Byte #<br>(decimal) | Byte #<br>(hex) | Field Name and Comments  | Value<br>(hex) | Value<br>(binary) |
|---------------------|-----------------|--|----------------|-------------------|
| 42                  | 2A              | Standard timing ID # 3   | TBD            | TBD               |
| 43                  | 2B              | Standard timing ID # 3   | TBD            | TBD               |
| 44                  | 2C              | Standard timing ID # 4   | TBD            | TBD               |
| 45                  | 2D              | Standard timing ID # 4   | TBD            | TBD               |
| 46                  | 2E              | Standard timing ID # 5   | TBD            | TBD               |
| 47                  | 2F              | Standard timing ID # 5   | TBD            | TBD               |
| 48                  | 30              | Standard timing ID # 6   | TBD            | TBD               |
| 49                  | 31              | Standard timing ID # 6   | TBD            | TBD               |
| 50                  | 32              | Standard timing ID # 7   | TBD            | TBD               |
| 51                  | 33              | Standard timing ID # 7   | TBD            | TBD               |
| 52                  | 34              | Standard timing ID # 8   | TBD            | TBD               |
| 53                  | 35              | Standard timing ID # 8   | TBD            | TBD               |
| 54                  | 36              | Detailed timing description # 1 Pixel clock ( "65 MHz" )                                     | TBD            | TBD               |
| 55                  | 37              | # 1 Pixel clock (hex LSB first)  | TBD            | TBD               |
| 56                  | 38              | # 1 H active ( "1024" )  | TBD            | TBD               |
| 57                  | 39              | # 1 H blank ( "320" )  | TBD            | TBD               |
| 58                  | 3A              | # 1 H active: H blank ( "1024 : 320" )   | TBD            | TBD               |
| 59                  | 3B              | # 1 V active ( " 768" )  | TBD            | TBD               |
| 60                  | 3C              | # 1 V blank ( " 38" )  | TBD            | TBD               |
| 61                  | 3D              | # 1 V active: V blank ( " 768 : 38" )  | TBD            | TBD               |
| 62                  | 3E              | # 1 H sync offset ( " 24" )  | TBD            | TBD               |
| 63                  | 3F              | # 1 H sync pulse width ( " 136" )  | TBD            | TBD               |
| 64                  | 40              | # 1 V sync offset: V sync pulse width ( " 3 : 6" )   | TBD            | TBD               |
| 65                  | 41              | # 1 H sync offset: H sync pulse width : V sync offset : V sync width ( " 24 : 136 : 3 : 6" ) | TBD            | TBD               |
| 66                  | 42              | # 1 H image size ( " 285 mm" )   | TBD            | TBD               |
| 67                  | 43              | # 1 V image size ( " 214 mm" )   | TBD            | TBD               |
| 68                  | 44              | # 1 H image size: V image size ( " 285 : 214" )  | TBD            | TBD               |
| 69                  | 45              | # 1 H boarder ( " 0" )   | TBD            | TBD               |
| 70                  | 46              | # 1 V boarder ( " 0" )   | TBD            | TBD               |
| 71                  | 47              | # 1 Flags ( " Non-Interlace, Non-Stereo, Digital Separate" )                                 | TBD            | TBD               |
| 72                  | 48              | Detailed timing description # 2  | TBD            | TBD               |
| 73                  | 49              | # 2 Flag   | TBD            | TBD               |
| 74                  | 4A              | # 2 Reserved   | TBD            | TBD               |
| 75                  | 4B              | # 2 FE (hex) defines ASCII string (Model Name "N141X5" , ASCII)                              | TBD            | TBD               |
| 76                  | 4C              | # 2 Flag   | TBD            | TBD               |
| 77                  | 4D              | # 2 1st character of string ( "N" )  | TBD            | TBD               |
| 78                  | 4E              | # 2 2nd character of string ( "1" )  | TBD            | TBD               |
| 79                  | 4F              | # 2 3rd character of string ( "4" )  | TBD            | TBD               |
| 80                  | 50              | # 2 4th character of string ( "1" )  | TBD            | TBD               |
| 81                  | 51              | # 2 5th character of string ( "X" )  | TBD            | TBD               |
| 82                  | 52              | # 2 6th character of string ( "7" )  | TBD            | TBD               |
| 83                  | 53              | # 2 New line character # 2 indicates end of ASCII string                                     | TBD            | TBD               |
| 84                  | 54              | # 2 Padding with "Blank" character   | TBD            | TBD               |
| 85                  | 55              | # 2 Padding with "Blank" character   | TBD            | TBD               |
| 86                  | 56              | # 2 Padding with "Blank" character   | TBD            | TBD               |

| Byte #<br>(decimal) | Byte #<br>(hex) | Field Name and Comments   | Value<br>(hex) | Value<br>(binary) |
|---------------------|-----------------|---|----------------|-------------------|
| 87                  | 57              | # 2 Padding with "Blank" character                              | TBD            | TBD               |
| 88                  | 58              | # 2 Padding with "Blank" character                              | TBD            | TBD               |
| 89                  | 59              | # 2 Padding with "Blank" character                              | TBD            | TBD               |
| 90                  | 5A              | Detailed timing description # 3                                 | TBD            | TBD               |
| 91                  | 5B              | # 3 Flag  | TBD            | TBD               |
| 92                  | 5C              | # 3 Reserved  | TBD            | TBD               |
| 93                  | 5D              | # 3 FE (hex) defines ASCII string (Model Name "N141X5" , ASCII) | TBD            | TBD               |
| 94                  | 5E              | # 3 Flag  | TBD            | TBD               |
| 95                  | 5F              | # 3 1st character of string ( "N" )                             | TBD            | TBD               |
| 96                  | 60              | # 3 2nd character of string ( "1" )                             | TBD            | TBD               |
| 97                  | 61              | # 3 3rd character of string ( "4" )                             | TBD            | TBD               |
| 98                  | 62              | # 3 4th character of string ( "1" )                             | TBD            | TBD               |
| 99                  | 63              | # 3 5th character of string ( "X" )                             | TBD            | TBD               |
| 100                 | 64              | # 3 6th character of string ( "7" )                             | TBD            | TBD               |
| 101                 | 65              | # 3 New line character # 3 indicates end of ASCII string        | TBD            | TBD               |
| 102                 | 66              | # 3 Padding with "Blank" character                              | TBD            | TBD               |
| 103                 | 67              | # 3 Padding with "Blank" character                              | TBD            | TBD               |
| 104                 | 68              | # 3 Padding with "Blank" character                              | TBD            | TBD               |
| 105                 | 69              | # 3 Padding with "Blank" character                              | TBD            | TBD               |
| 106                 | 6A              | # 3 Padding with "Blank" character                              | TBD            | TBD               |
| 107                 | 6B              | # 3 Padding with "Blank" character                              | TBD            | TBD               |
| 108                 | 6C              | Detailed timing description # 4                                 | TBD            | TBD               |
| 109                 | 6D              | # 4 Flag  | TBD            | TBD               |
| 110                 | 6E              | # 4 Reserved  | TBD            | TBD               |
| 111                 | 6F              | # 4 FC (hex) defines Monitor name ( "Color LCD" , ASCII)        | TBD            | TBD               |
| 112                 | 70              | # 4 Flag  | TBD            | TBD               |
| 113                 | 71              | # 4 1st character of name ( "C" )                               | TBD            | TBD               |
| 114                 | 72              | # 4 2nd character of name ( "o" )                               | TBD            | TBD               |
| 115                 | 73              | # 4 3rd character of name ( "I" )                               | TBD            | TBD               |
| 116                 | 74              | # 4 4th character of name ( "o" )                               | TBD            | TBD               |
| 117                 | 75              | # 4 5th character of name ( "r" )                               | TBD            | TBD               |
| 118                 | 76              | # 4 6th character of name (<space>)                             | TBD            | TBD               |
| 119                 | 77              | # 4 7th character of name ( "L" )                               | TBD            | TBD               |
| 120                 | 78              | # 4 8th character of name ( "C" )                               | TBD            | TBD               |
| 121                 | 79              | # 4 9th character of name ( "D" )                               | TBD            | TBD               |
| 122                 | 7A              | # 4 New line character # 4 indicates end of Monitor name        | TBD            | TBD               |
| 123                 | 7B              | # 4 Padding with "Blank" character                              | TBD            | TBD               |
| 124                 | 7C              | # 4 Padding with "Blank" character                              | TBD            | TBD               |
| 125                 | 7D              | # 4 Padding with "Blank" character                              | TBD            | TBD               |
| 126                 | 7E              | Extension flag  | TBD            | TBD               |
| 127                 | 7F              | Checksum  | TBD            | TBD               |



## 5.6 EDID SIGNAL SPECIFICATION

## (1) EDID Power

| Parameter            | Symbol | Conditions     | Min. | Typ. | Max. | Unit |
|----------------------|--------|----------------|------|------|------|------|
| Power supply voltage | Vcc    | Read Operation | 2.2  | —    | 5.5  | V    |

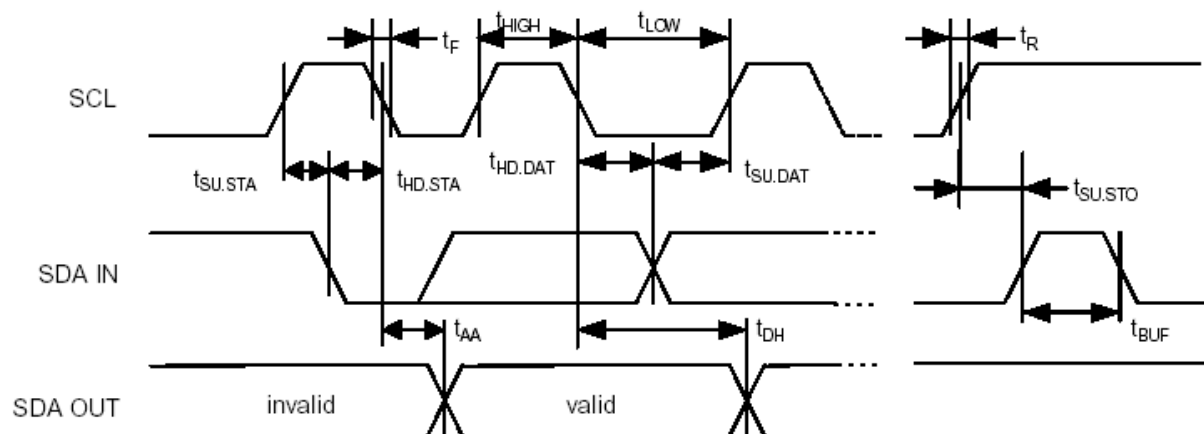

## (2) DC characteristics

|   |              | Symbol                | Min.       | Max.       | Unit | Index                                |
|---|--------------|-----------------------|------------|------------|------|--------------------------------------|
| SCL, SDA terminal input voltage                             | High Voltage | VIH                   | 0.7×Vcc    | —          | V    |                                      |
|   | Low Voltage  | VIL                   | —          | 0.3×Vcc    | V    |                                      |
| Hysteresis Voltage  |              | VHYS                  | 0.05 VCC   | —          | V    |                                      |
| Output Voltage  |              | VOL1<br>VOL2          | —          | 0.4<br>0.6 | V    | IOL=3mA, CC=2.5V<br>IOL=6mA, CC=2.5V |
| Input Leak current<br>(Vin =0.1V~VCC)                       |              | ILI                   | -10<br>-10 | 10<br>50   | uA   | WP=VSS<br>WP=VCC                     |
| Output Leak current   |              | ILO                   | -10        | 10         | uA   | Vout =0.1V~VCC,<br>WP=VSS            |
| Terminal capacity(Input, Output)                            |              | Cin, Cout             | —          | 10         | pF   | VCC=5.0V<br>Ta=25°C,<br>Fclk=1.0MHz  |
| Operating current   |              | ICC Write<br>ICC Read | —          | 3<br>1     | mA   | VCC=5.5V,<br>SCL=400KHz              |
| Stillness current<br>(SDA=SCL=VCC)<br>(WP=VSS,A0,A1,A2=VSS) |              | ICCS                  | —          | 30<br>100  | uA   | VCC=3.0V<br>VCC=5.5V                 |

## (3) AC characteristics (VCC=2.5~5.5V standard operation mode)

| Item                                  | Symbol    | VCC=2.5V-5.5V<br>(Standard operation mode) |      | VCC=4.5V-5.5V<br>(High-speed operation mode) |      | Unit   | Index                |
|---------------------------------------|-----------|--|------|--|------|--------|----------------------|
|                                       |           | Min.                                       | Max. | Min.   | Max. |        |                      |
| Clock frequency                       | Fclk      | —  | 100  | —  | 400  | KHz    |                      |
| Clock High Time                       | THIGH     | 4000                                       | —    | 900  | —    | ns     |                      |
| Clock Low Time                        | TLOW      | 4700                                       | —    | 1300   | —    | ns     |                      |
| SDA, SCL falling time                 | TR        | —  | 1000 | —  | 300  | ns     |                      |
| SDA, SCL rising time                  | TF        | —  | 300  | —  | 300  | ns     |                      |
| START hold time                       | THD: STA  | 4000                                       | —    | 600  | —    | ns     |                      |
| START setup time                      | TSU: STA  | 4700                                       | —    | 600  | —    | ns     |                      |
| Data input hold time                  | THD: Data | 0  | —    | 0  | —    | ns     |                      |
| Data input setup time                 | TSU: Data | 250  | —    | 100  | —    | ns     |                      |
| STOP setup time                       | TSU: STO  | 4700                                       | —    | 600  | —    | ns     |                      |
| Output decision time from a clock     | TAA       | —  | 3500 | 100  | 900  | ns     |                      |
| Bus free time                         | TBUF      | 4700                                       | —    | 1300   | —    | ns     |                      |
| Rising time of Min VIH, VIL           | TOF       | —  | 250  | 20   | 250  | ns     | CB ≤ 100pF           |
| Spike oppression                      | TSP       | —  | 50   | —  | 50   | ns     |                      |
| A write-in cycle time                 | TWR       | —  | 10   | —  | 10   | ms     | Byte and page mode   |
| The number of times of data rewriting | —         | 1M   | —    | 1M   | —    | cycles | VCC=5.0V<br>Ta=25°C, |

## 6. INTERFACE TIMING

### 6.1 INPUT SIGNAL TIMING SPECIFICATIONS

The input signal timing specifications are shown as the following table and timing diagram.

| Signal                         | Item           | Symbol           | Min. | Typ. | Max. | Unit   | Note |
|--------------------------------|----------------|------------------|------|------|------|--------|------|
| Clock                          | Frequency      | 1/Tc             | 40   | 65   | 80   | MHz    | -    |
|                                | High Time      | T <sub>CH</sub>  | 13   | -    | -    | nsec   | -    |
|                                | Low Time       | T <sub>CL</sub>  | 13   | -    | -    | nsec   | -    |
| Data                           | Setup Time     | T <sub>DS</sub>  | 4    | -    | -    | nsec   | -    |
|                                | Hold Time      | T <sub>DH</sub>  | 4    | -    | -    | nsec   | -    |
| Vsync Frequency                | Frequency      | Vsync            | -    | 60   | -    | Hz     | -    |
| Hsync Frequency                | Frequency      | Hsync            | -    | 48   | -    | KHz    | -    |
| Data Enable                    | Pulse width    | T <sub>DEP</sub> | 100  | -    | -    | clocks | (1)  |
| Data Enable                    | Setup Time     | T <sub>ES</sub>  | 3.5  | 4.0  | -    | nsec   | (1)  |
| Frame Frequency                | Cycle          | T <sub>V</sub>   | 770  | 806  | 1000 | lines  | -    |
| Vertical Active Display Term   | Display Period | T <sub>VD</sub>  | -    | 768  | -    | lines  | -    |
| One Line Scanning Time         | Cycle          | T <sub>H</sub>   | 1180 | 1344 | 2000 | clocks | (2)  |
| Horizontal Active Display Term | Display Period | T <sub>HD</sub>  | -    | 1024 | -    | clocks | -    |

Note (1) Because this module is operated by DE only mode, Hsync and Vsync input signals should be set to low logic level or ground. Otherwise, this module would operate abnormally.

Note (2) The duration of DE signal must be longer than 1 clock period at every horizontal sync. period.

#### INPUT SIGNAL TIMING DIAGRAM

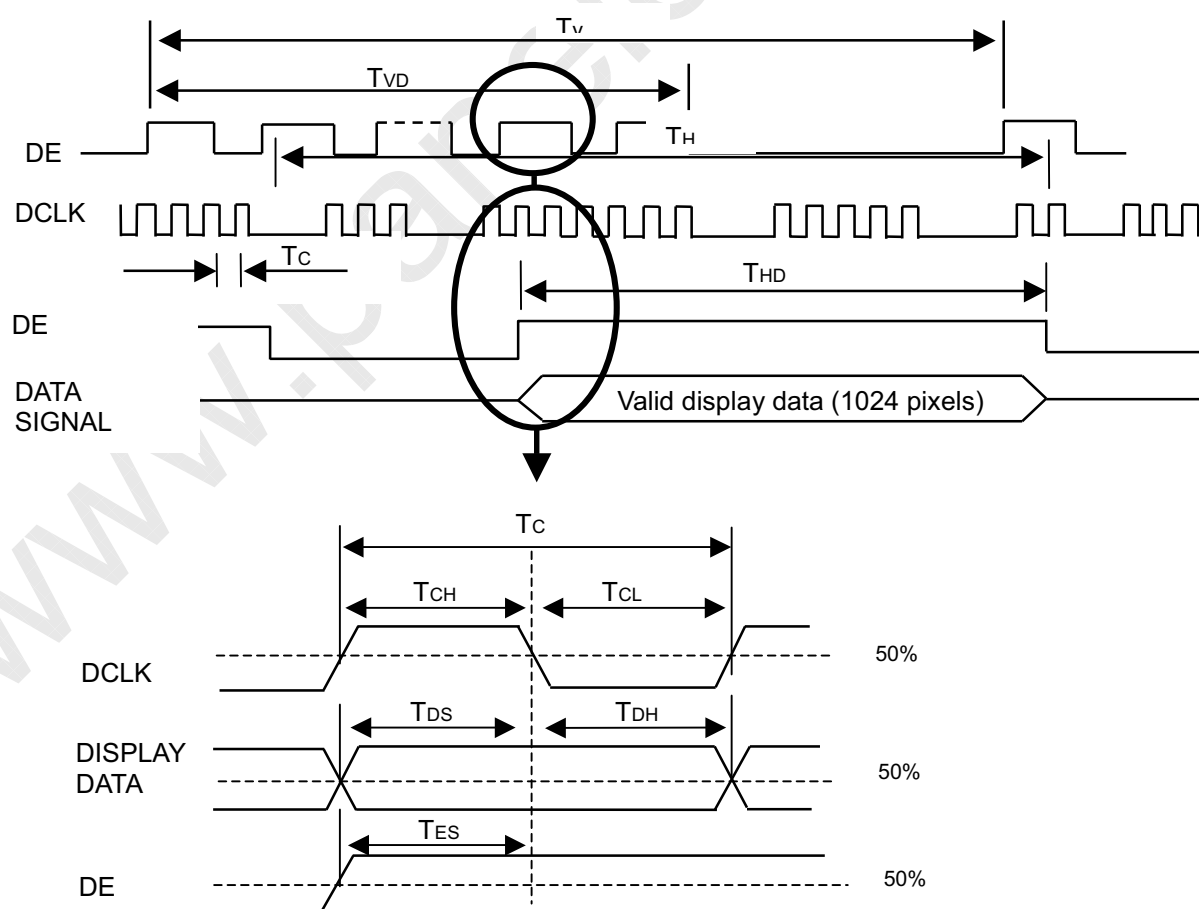

## 6.2 POWER ON/OFF SEQUENCE

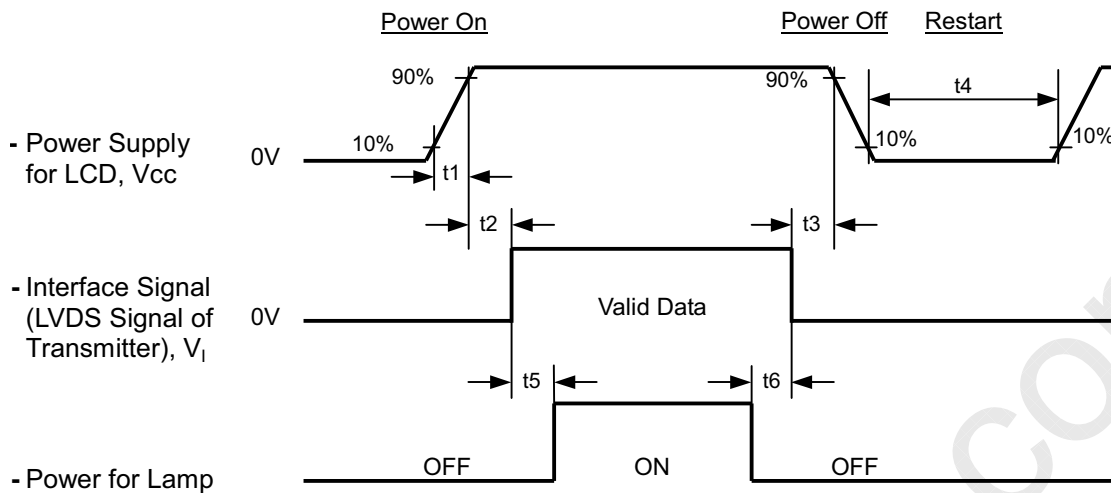

## Timing Specifications:

$$0 < t_1 \leq 15 \text{ msec}$$

$$0 < t_2 \leq 45 \text{ msec}$$

$$0 < t_3 \leq 45 \text{ msec}$$

$$t_4 \geq 400 \text{ msec}$$

$$t_5 \geq 200 \text{ msec}$$

$$t_6 \geq 200 \text{ msec}$$

Note (1) Please avoid floating state of interface signal at invalid period.

Note (2) When the interface signal is invalid, be sure to pull down the power supply of LCD V<sub>cc</sub> to 0 V.

Note (3) The Backlight inverter power must be turned on after the power supply for the logic and the interface signal is valid. The Backlight inverter power must be turned off before the power supply for the logic and the interface signal is invalid.

## 7. OPTICAL CHARACTERISTICS

### 7.1 TEST CONDITIONS

| Item                       | Symbol  | Value | Unit |
|----------------------------|---|-------|------|
| Ambient Temperature        | Ta  | 25±2  | °C   |
| Ambient Humidity           | Ha  | 50±10 | %RH  |
| Supply Voltage             | V <sub>CC</sub>   | 3.3   | V    |
| Input Signal               | According to typical value in "3. ELECTRICAL CHARACTERISTICS" |       |      |
| Inverter Current           | I <sub>L</sub>  | 6.5   | mA   |
| Inverter Driving Frequency | F <sub>L</sub>  | 55    | KHz  |
| Inverter                   | Sumida-H05-4783B  |       |      |

The measurement methods of optical characteristics are shown in Section 7.2. The following items should be measured under the test conditions described in Section 7.1 and stable environment shown in Note (6).

### 7.2 OPTICAL SPECIFICATIONS

| Item                       | Symbol           | Condition  | Min.           | Typ.    | Max.    | Unit              | Note     |          |
|----------------------------|------------------|--|----------------|---------|---------|-------------------|----------|----------|
| Contrast Ratio             | CR               | $\theta_x=0^\circ, \theta_y=0^\circ$<br>Viewing Normal Angle | (200)          | (250)   | -       | -                 | (2), (6) |          |
| Response Time              | T <sub>R</sub>   |  | -              | 15      | 30      | ms                | (3)      |          |
|                            | T <sub>F</sub>   |  | -              | 35      | 50      | ms                |          |          |
| Average Luminance of White | L <sub>Ave</sub> |  | (140)          | (170)   | -       | cd/m <sup>2</sup> | (4), (6) |          |
| White Variation            | $\delta W$       |  | -              | -       | (1.4)   | -                 | (6), (7) |          |
| Cross Talk                 | CT               |  | -              | -       | (4.0)   | %                 | (5), (6) |          |
| Color Chromaticity         | Red              |  | R <sub>x</sub> | (0.537) | (0.577) | (0.617)           | -        | (1), (6) |
|                            |                  |  | R <sub>y</sub> | (0.308) | (0.338) | (0.368)           | -        |          |
|                            | Green            |  | G <sub>x</sub> | (0.280) | (0.310) | (0.340)           | -        |          |
|                            |                  |  | G <sub>y</sub> | (0.524) | (0.554) | (0.584)           | -        |          |
|                            | Blue             | B <sub>x</sub>   | (0.128)        | (0.158) | (0.188) | -                 |          |          |
|                            |                  | B <sub>y</sub>   | (0.084)        | (0.124) | (0.164) | -                 |          |          |
| White                      | W <sub>x</sub>   | (0.283)  | 0.313          | (0.343) | -       |                   |          |          |
|                            | W <sub>y</sub>   | (0.299)  | 0.329          | (0.359) | -       |                   |          |          |
| Color Gamut                | C.G%             |  | 45             | -       | %       | (8)               |          |          |
| Viewing Angle              | Horizontal       | $\theta_{x+}$  | 40             | 45      | -       | Deg.              | (1), (6) |          |
|                            |                  | $\theta_{x-}$  | 40             | 45      | -       |                   |          |          |
|                            | Vertical         | $\theta_{y+}$  | 10             | 15      | -       |                   |          |          |
|                            |                  | $\theta_{y-}$  | 30             | 35      | -       |                   |          |          |

Note (1) Definition of Viewing Angle ( $\theta_x$ ,  $\theta_y$ ):

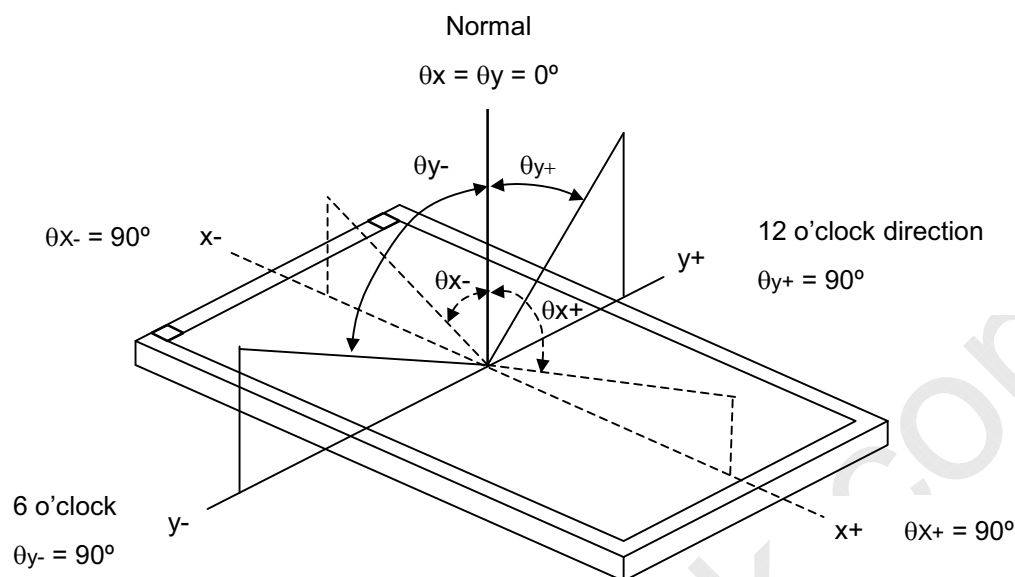

Note (2) Definition of Contrast Ratio (CR):

The contrast ratio can be calculated by the following expression.

$$\text{Contrast Ratio (CR)} = L_{63} / L_0$$

L<sub>63</sub>: Luminance of gray level 63

L<sub>0</sub>: Luminance of gray level 0

$$\text{CR} = \text{CR} (5)$$

CR (X) is corresponding to the Contrast Ratio of the point X at Figure in Note (7).

Note (3) Definition of Response Time ( $T_R$ ,  $T_F$ ):

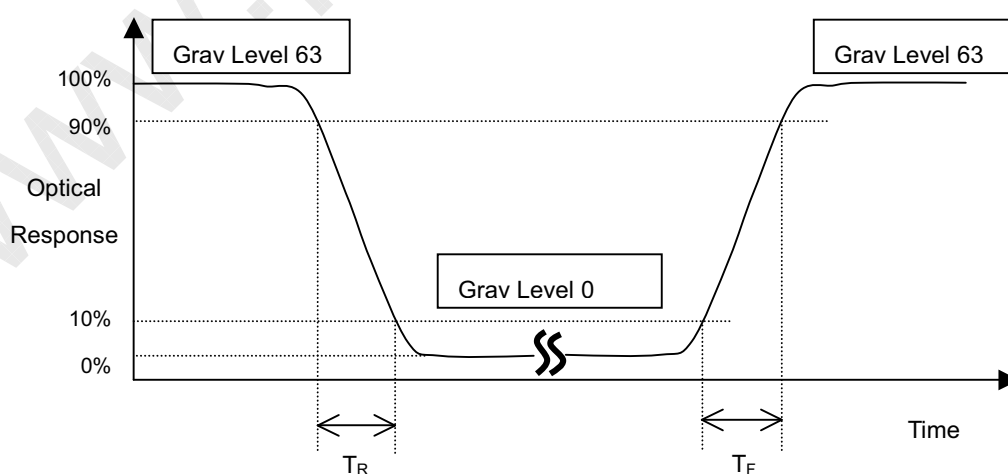

Note (4) Definition of Average Luminance of White ( $L_{AVE}$ ):

Measure the luminance of gray level 63 at 5 points

$$L_{AVE} = [L(1) + L(2) + L(3) + L(4) + L(5)] / 5$$

$L(x)$  is corresponding to the luminance of the point X at Figure in Note (7).

Note (5) Definition of Cross Talk (CT):

$$CT = |Y_B - Y_A| / Y_A \times 100 (\%)$$

Where:

$Y_A$  = Luminance of measured location without gray level 0 pattern ( $cd/m^2$ )

$Y_B$  = Luminance of measured location with gray level 0 pattern ( $cd/m^2$ )

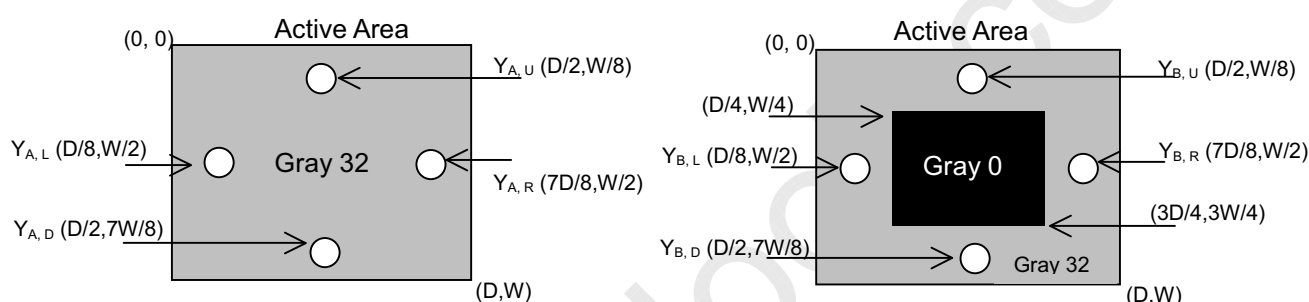

Note (6) Measurement Setup:

The LCD module should be stabilized at given temperature for 20 minutes to avoid abrupt temperature change during measuring. In order to stabilize the luminance, the measurement should be executed after lighting Backlight for 20 minutes in a windless room.

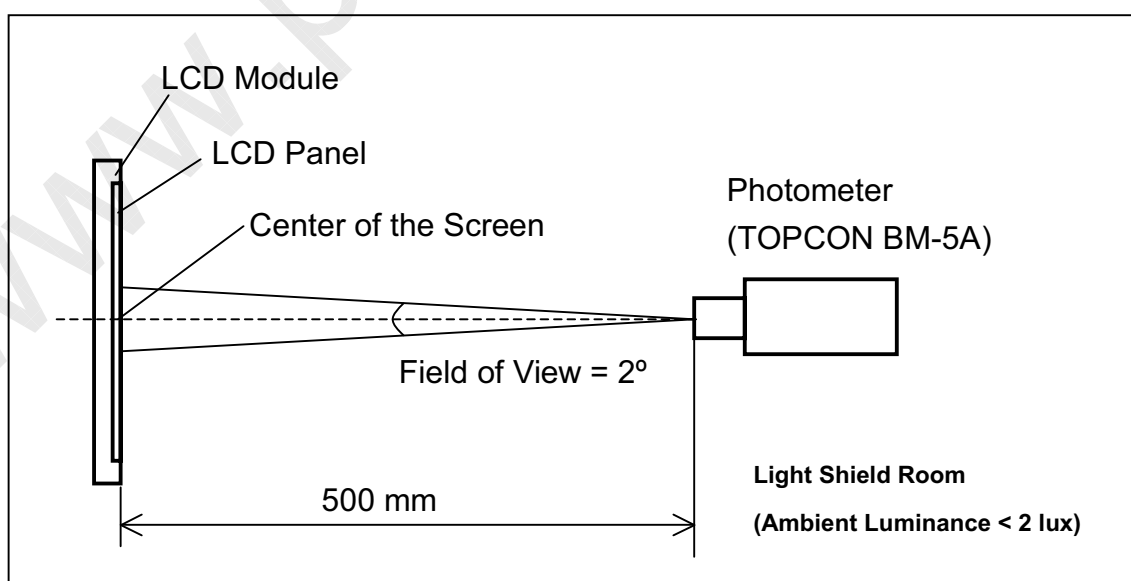

Note (7) Definition of White Variation ( $\delta W$ ):

Measure the luminance of gray level 63 at 5 points

$$\delta W = \text{Maximum [L (1), L (2), L (3), L (4), L (5)] / Minimum [L (1), L (2), L (3), L (4), L (5)]}$$

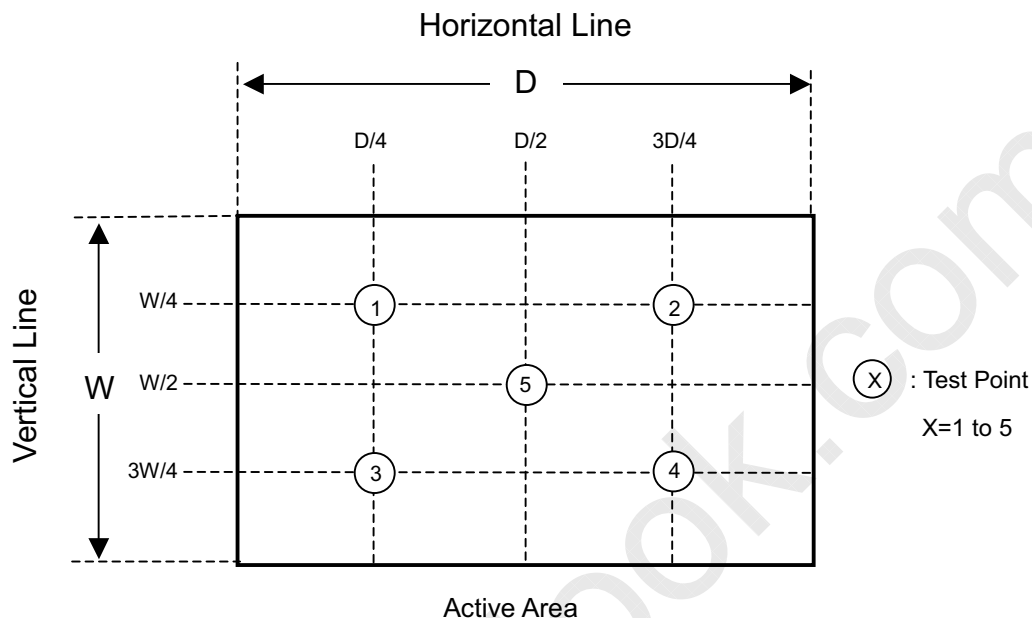

Note (8) Definition of color gamut (C.G%):

$$C.G\% = \Delta R G B / \Delta R_0 G_0 B_0, *100\%$$

$R_0, G_0, B_0$ : color coordinates of red, green, and blue defined by NTSC, respectively.

$R, G, B$ : color coordinates of module on 63 gray levels of red, green, and blue, respectively.

$\Delta R_0 G_0 B_0$ : area of triangle defined by  $R_0, G_0, B_0$

$\Delta R G B$ : area of triangle defined by  $R, G, B$

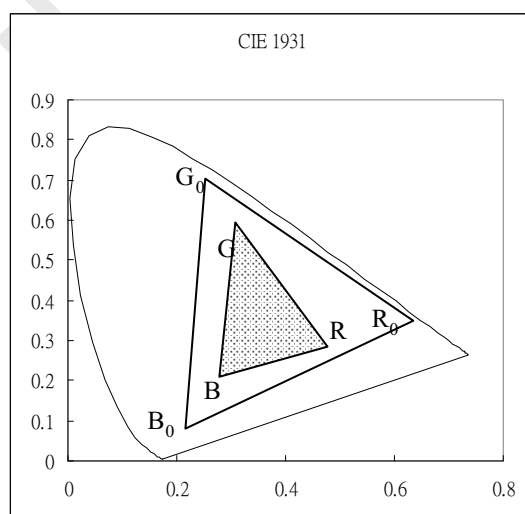



## 8. PRECAUTIONS

### 8.1 HANDLING PRECAUTIONS

- (1) The module should be assembled into the system firmly by using every mounting hole. Be careful not to twist or bend the module.
- (2) While assembling or installing modules, it can only be in the clean area. The dust and oil may cause electrical short or damage the polarizer.
- (3) Use fingerstalls or soft gloves in order to keep display clean during the incoming inspection and assembly process.
- (4) Do not press or scratch the surface harder than a HB pencil lead on the panel because the polarizer is very soft and easily scratched.
- (5) If the surface of the polarizer is dirty, please clean it by some absorbent cotton or soft cloth. Do not use Ketone type materials (ex. Acetone), Ethyl alcohol, Toluene, Ethyl acid or Methyl chloride. It might permanently damage the polarizer due to chemical reaction.
- (6) Wipe off water droplets or oil immediately. Staining and discoloration may occur if they left on panel for a long time.
- (7) If the liquid crystal material leaks from the panel, it should be kept away from the eyes or mouth. In case of contacting with hands, legs or clothes, it must be washed away thoroughly with soap.
- (8) Protect the module from static electricity, it may cause damage to the C-MOS Gate Array IC.
- (9) Do not disassemble the module.
- (10) Do not pull or fold the lamp wire.
- (11) Pins of I/F connector should not be touched directly with bare hands.

### 8.2 STORAGE PRECAUTIONS

- (1) High temperature or humidity may reduce the performance of module. Please store LCD module within the specified storage conditions.
- (2) It is dangerous that moisture come into or contacted the LCD module, because the moisture may damage LCD module when it is operating.
- (3) It may reduce the display quality if the ambient temperature is lower than 10 °C. For example, the response time will become slowly, and the starting voltage of lamp will be higher than the room temperature.

### 8.3 OPERATION PRECAUTIONS

- (1) Do not pull the I/F connector in or out while the module is operating.
- (2) Always follow the correct power on/off sequence when LCD module is connecting and operating. This can prevent the CMOS LSI chips from damage during latch-up.
- (3) The startup voltage of Backlight is approximately 1000 Volts. It may cause electrical shock while assembling with inverter. Do not disassemble the module or insert anything into the Backlight unit.

## 9. PACKING

## 9.1 CARTON

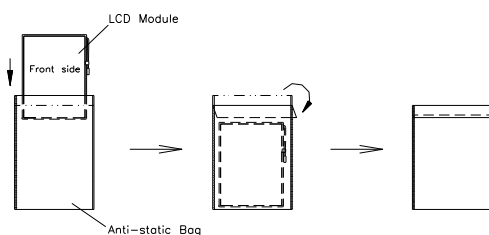

Box dimensions: 422(L)x337(W)x345(H)mm  
Weight: Approx. 7.0Kg(10modules per 1 box)

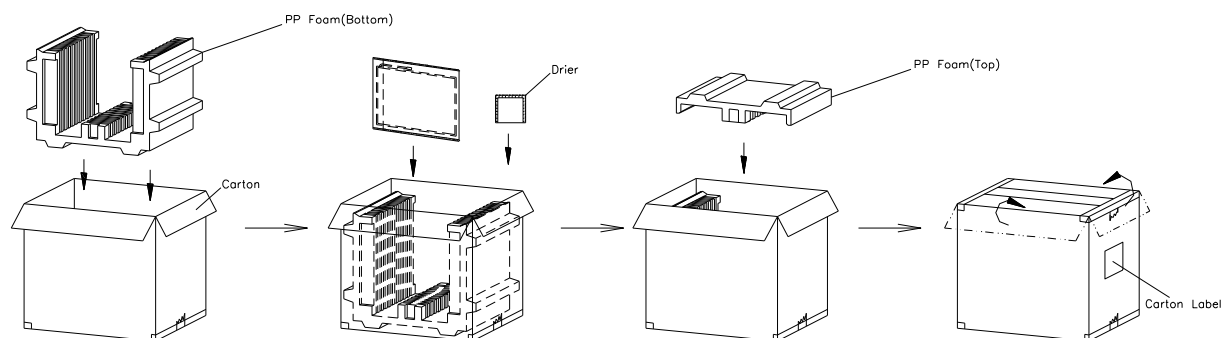

## 9.2 PALLET

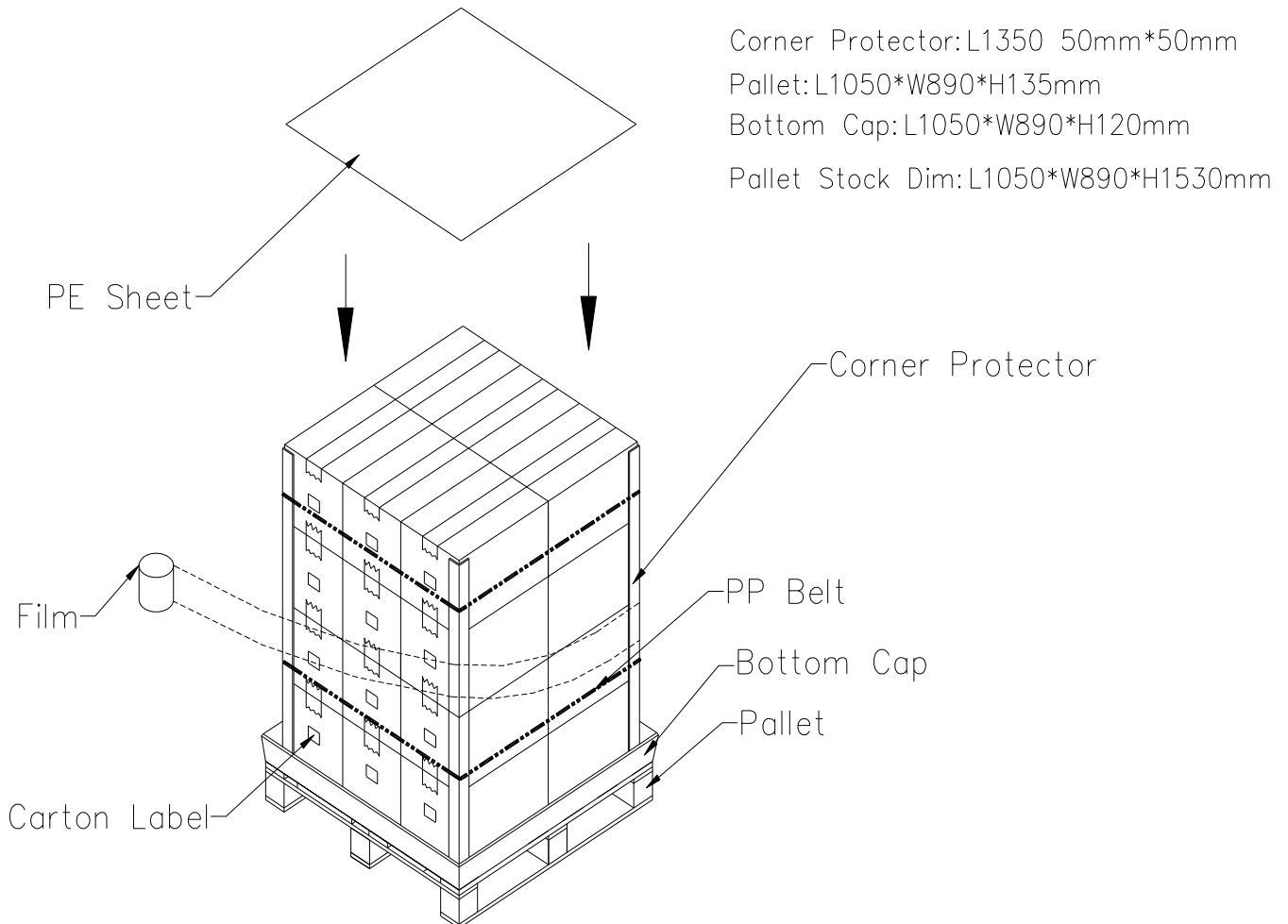

## 10. DEFINITION OF LABELS

### 10.1 CMO MODULE LABEL

The barcode nameplate is pasted on each module as illustration, and its definitions are as following explanation.

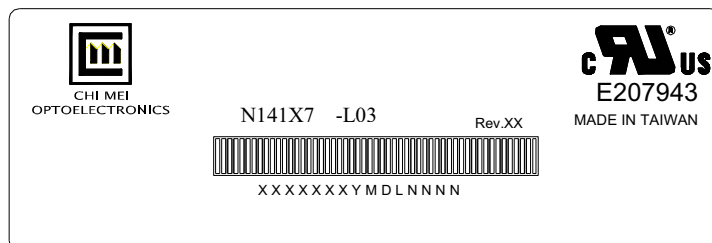

- (a) Model Name: N141X7 - L03  
(b) Revision: Rev. XX, for example: C1, C2 ...etc.  
(c) Serial ID: XXXXXXYMDLNNNN

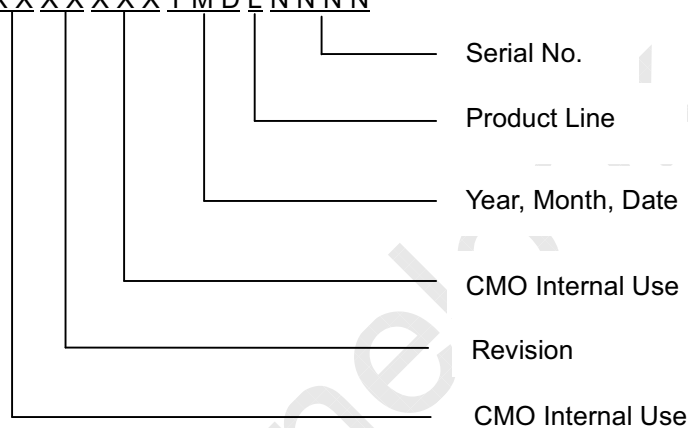

Serial ID includes the information as below:

- (a) Manufactured Date: Year: 1~9, for 2001~2009  
Month: 1~9, A~C, for Jan. ~ Dec.  
Day: 1~9, A~Y, for 1<sup>st</sup> to 31<sup>st</sup>, exclude I , O and U
- (b) Revision Code: cover all the change  
(c) Serial No.: Manufacturing sequence of product  
(d) Product Line: 1 -> Line1, 2 -> Line 2, ...etc.

## 10.2 CARTON LABEL

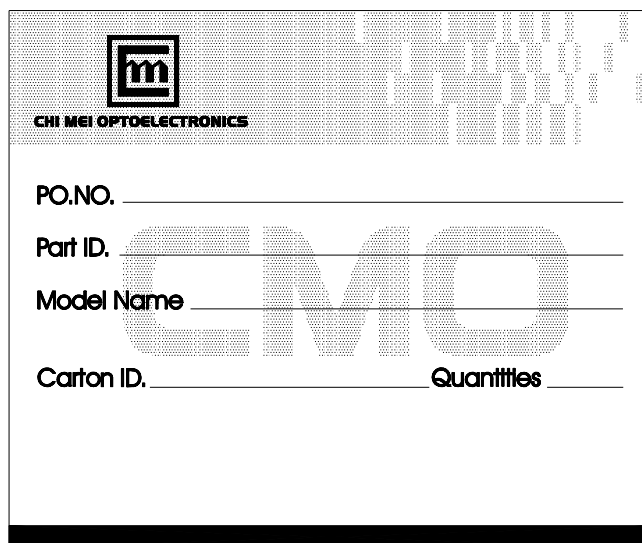

CHI MEI OPTOELECTRONICS

PO.NO. \_\_\_\_\_

Part ID. \_\_\_\_\_

Model Name \_\_\_\_\_

Carton ID. \_\_\_\_\_ Quantities \_\_\_\_\_

www.panelook.com

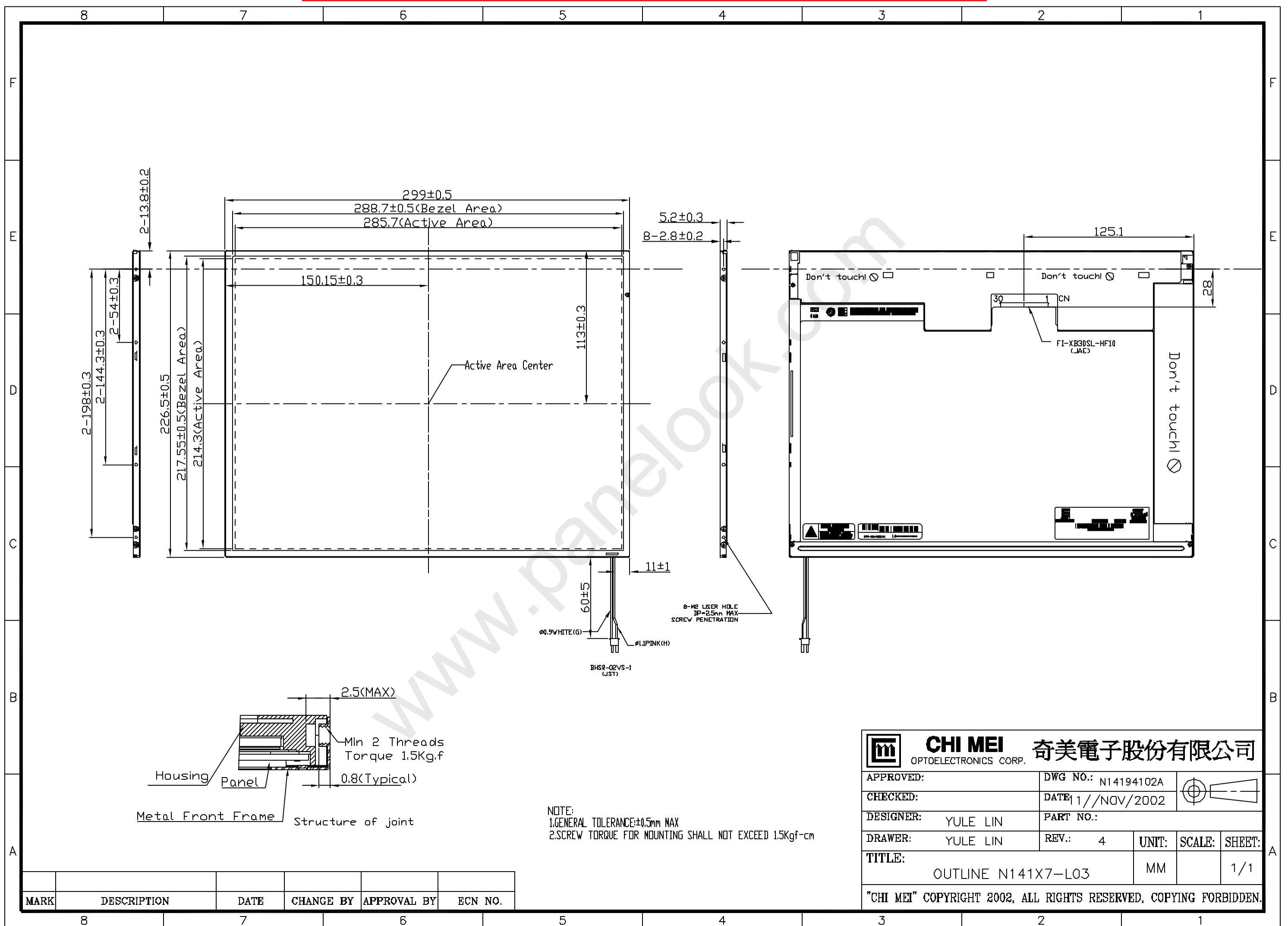

|   |                     |                           |                   |
|---|---------------------|---------------------------|-------------------|
|   |                     | <b>CHI MEI</b> 奇美電子股份有限公司 |                   |
| OPTOELECTRONICS CORP.   |                     |                           |                   |
| APPROVED:   | DWG NO.: N14194102A |                           |                   |
| CHECKED:  | DATE: 11/NOV/2002   |                           |                   |
| DESIGNER: YULE LIN  | PART NO.:           |                           |                   |
| DRAWER: YULE LIN  | REV.: 4             | UNIT: MM                  | SCALE: SHEET: 1/1 |
| TITLE: OUTLINE N141X7-L03   |                     |                           |                   |
| "CHI MEI" COPYRIGHT 2002, ALL RIGHTS RESERVED, COPYING FORBIDDEN. |                     |                           |                   |

| MARK | DESCRIPTION | DATE | CHANGE BY | APPROVAL BY | ECN NO. |
|------|-------------|------|-----------|-------------|---------|
| 8    |             | 7    |           | 6           |         |
|      |             |      |           |             |         |
|      |             |      |           |             |         |
|      |             |      |           |             |         |
|      |             |      |           |             |         |