

TFT LCD Approval Specification



MODEL NO.: N150X1-L02

Customer: Fujitsu Limited

Approved by:

Note:

www.jxlcd.com

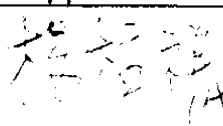
Liquid Crystal Display Division		
QRA Dept.	PDD II Dept.	PD Dept.
Approval	Approval	Approval
		

- CONTENTS -

REVISION HISTORY	-----	3
1. GENERAL DESCRIPTION	-----	5
1.1 OVERVIEW		
1.2 FEATURES		
1.3 APPLICATION		
1.4 GENERAL SPECIFICATIONS		
1.5 MECHANICAL SPECIFICATIONS		
2. ABSOLUTE MAXIMUM RATINGS	-----	6
2.1 ABSOLUTE RATINGS OF ENVIRONMENT		
2.2 ELECTRICAL ABSOLUTE RATINGS		
2.2.1 TFT LCD MODULE		
2.2.2 BACKLIGHT UNIT		
3. ELECTRICAL CHARACTERISTICS	-----	7
3.1 TFT LCD MODULE		
3.2 BACKLIGHT UNIT		
3.3 EDID DATA		
4. BLOCK DIAGRAM	-----	13
4.1 TFT LCD MODULE		
4.2 BACKLIGHT UNIT		
5. INPUT TERMINAL PIN ASSIGNMENT	-----	14
5.1 TFT LCD MODULE		
5.2 BACKLIGHT UNIT		
5.3 TIMING DIAGRAM OF LVDS INPUT SIGNAL		
5.4 COLOR DATA INPUT ASSIGNMENT		
6. INTERFACE TIMING	-----	16
6.1 INPUT SIGNAL TIMING SPECIFICATIONS		
6.2 POWER ON/OFF SEQUENCE		
7. OPTICAL CHARACTERISTICS	-----	18
7.1 TEST CONDITIONS		
7.2 OPTICAL SPECIFICATIONS		
8. DEFINITION OF LABELS	-----	23
8.1 CMO MODULE LABEL		
8.2 CARTON LABEL		
9. Packing	-----	24
9.1 Carton		
9.2 Pallet		
10. PRECAUTIONS	-----	26
10.1 ASSEMBLY AND HANDLING PRECAUTIONS		
10.2 SAFETY PRECAUTIONS		

REVISION HISTORY

Version	Date	Section	Description
Ver 0.0	Oct.19,'02	All	Tentative Specification was first issued.
Ver 1.0	Jul. 2,'02	All	Spec. was revised to preliminary 1.0 version.
Ver 3.0	Aug.13'02	All	<p>Page 2 - <u>CONTENTS</u></p> <p>Add "1.5 mechanical specification" & "3.3 EDID data"</p> <p>Page 5 – <u>1.5 MECHANICAL SPECIFICATIONS</u></p> <p>Modify item 1.5 mechanical specification:</p> <p>Add Depth "min. 6.4" & "max. 7.0"</p> <p>Weight typ. 590 instead of 610; max. 605 instead 615</p> <p>Add connector mounting position drawing</p> <p>Page 7 – <u>2.2 ELECTRICAL ABSOLUTE RATINGS</u></p> <p>Modify the note of 2.2.2 BACKLIGHT UNIT to be "(1), (2), I_L = 6.0 mA"</p> <p>Page 9 – <u>3.2 BACKLIGHT UNIT</u></p> <p>add lamp input voltage "min.612", "typ.680"; "max.748" and I_L="6.0"mA</p> <p>Modify lamp current "min. 2.0" instead of "3.0"; "typ. 6.0" instead of "6.5"; "max. 6.5" instead of "7.0"</p> <p>Revise lamp turn on voltage "max.1150(25°C)" instead of "typ.1080(25°C)</p> <p>Revise lamp turn on voltage "max.1500(0°C)" instead of "typ.1290(0°C)</p> <p>Modify operating frequency "max 80" instead of "max.67"</p> <p>Add lamp life time to be "typ. 15,000"</p> <p>Revise power consumption "typ. 4.08" instead of "typ. 4.2" & note revised to be "(4), I_L = 6.0 mA"</p> <p>Note (5) The lifetime of lamp can be defined as the time in which it continues to operate under the condition Ta = 25 ±2 °C and I_L = 6.0 mA Arms until one of the following events occurs:</p> <p>Page 10 ~ 12 – <u>3.3 EDID DATA</u></p> <p>Add 3.3 EDID data in Page 10 ~ 12</p> <p>Page 16 – <u>6. INTERFACE TIMING</u></p> <p>6.1 Input Signal Timing Specification</p> <p>Add DCLK frequency min. 20 & max. 68</p> <p>Revise frame time cycle "min 771" instead of "min 770"; "max 850" instead of "max 1000"</p> <p>Page 18 – <u>6.2 POWER ON/OFF SEQUENCE</u></p> <p>Timing Specifications:</p> <p style="margin-left: 40px;">$0 < t_1 \leq 10 \text{ msec}$</p> <p style="margin-left: 40px;">$0 < t_2 \leq 50 \text{ msec}$</p> <p style="margin-left: 40px;">$0 < t_3 \leq 50 \text{ msec}$</p> <p style="margin-left: 40px;">$t_4 \geq 200 \text{ msec}$</p> <p style="margin-left: 40px;">$t_5 \geq 200 \text{ msec}$</p> <p style="margin-left: 40px;">$t_6 \geq 5 \text{ msec}$</p>
Version	Date	Section	Description

<p>3.1 3.2</p>	<p>Aug.,21'02 Sep. 4' 02</p>	<p style="text-align: center;"> $0 \leq t7 \leq 50 \text{ msec (given by system)}$ $0 \leq t7 \leq 400 \text{ msec (measured on TFT-LCD module)}$ </p> <p>Page 18 <u>7. OPTICAL CHARACTERISTICS</u> Revise inverter current value=6.0 instead of 6.5 Revise inverter driving frequency value=60 instead of 50</p> <p>Page.18 <u>7.2 OPTICAL SPECIFICATION</u> Add white variation 70% & color gamut: min 50% typ. 60% & surface reflection rate typ. 1.8% max. 2.0% Modify chromatics: Rx min.0.597 typ.0.627 max.0.657 Ry min.0.323 typ. 0.353 max.0.383 Gx min.0.268 typ. 0.298 max.0.328 Gy min.0.556 typ.0.586 max.0.616 Bx min.0.115 typ.0.145 max.0.175 By min.0.066 typ.0.096 max.0.126 Wx min.0.283 typ.0.313 max. 0.343 Wy min.0.299 typ.0.329 max.0.359</p> <p>Page.21 8.1 modify label to add Fujitsu san's product code & version no. Add Section 8.2 Carton Label Add Section 9 Packing 9.1 Carton 9.2 Pallet</p>
--------------------	----------------------------------	--

www.jxlcd.com

1. GENERAL DESCRIPTION

1.1 OVERVIEW

N150X1-L02 is a 15.0" TFT Liquid Crystal Display module with single CCFL Backlight unit and 20 pins LVDS interface. This module supports 1024 x 768 XGA mode and can display 262,144 colors. The optimum viewing angle is at 6 o'clock direction. The inverter module for Backlight is not built in.

1.2 FEATURES

- Thin and light weight
- XGA (1024 x 768 pixels) resolution
- DE (Data Enable) only mode
- 3.3V LVDS (Low Voltage Differential Signaling) interface with 1 pixel/clock

1.3 APPLICATION

- TFT LCD Notebook

1.4 GENERAL SPECIFICATIONS

Item	Specification	Unit	Note
Active Area	304.1 (H) x 228.1 (V) (15.0" diagonal)	mm	(1)
Bezel Opening Area	307.8 (H) x 231.6 (V)	mm	
Driver Element	passive TFT active matrix	-	-
Pixel Number	1024 x R,G,B x 768	pixel	-
Pixel Pitch	0.297 (H) x 0.297 (V)	mm	-
Pixel Arrangement	RGB vertical stripe	-	-
Display Colors	262,144	color	-
Transmissive Mode	Normally white	-	-
Surface Treatment	Hard coating (3H), Anti-glare (Haze 12)	-	-

1.5 MECHANICAL SPECIFICATIONS

Item	Min.	Typ.	Max.	Unit	Note	
Module Size	Horizontal(H)	316.8	317.3	317.8	mm	(1)
	Vertical(V)	241.5	242.0	242.5	mm	
	Depth(D)	6.4	6.7	7.0	mm	
Weight	-	590	605	g	-	

Note (1) Please refer to the attached drawings for more information of front and back outline dimensions.

(2) Connector mounting position

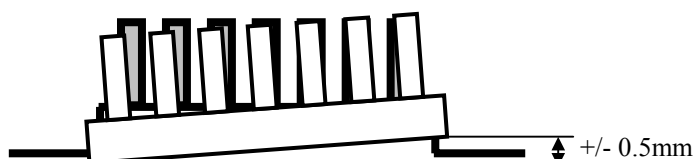

2. ABSOLUTE MAXIMUM RATINGS

2.1 ABSOLUTE RATINGS OF ENVIRONMENT

Item	Symbol	Value		Unit	Note
		Min.	Max.		
Storage Temperature	T _{ST}	-20	+60	°C	(1)
Operating Ambient Temperature	T _{OP}	0	+50	°C	(1), (2)
Shock (Non-Operating)	S _{NOP}	-	200	G	(3), (5)
Vibration (Non-Operating)	V _{NOP}	-	2.0	G	(4), (5)

Note (1) Temperature and relative humidity range is shown in the figure below.

- (a) 90 %RH Max. ($T_a \leq 40^\circ$)
- (b) Wet-bulb temperature should be 39 ° Max. ($T_a > 40^\circ$).
- (c) No condensation.

Note (2) The temperature of panel surface should be 0 °C Min. and 60 °C Max.

Note (3) 2ms, half sine wave, 1 time for $\pm X, \pm Y, \pm Z$.

Note (4) 10 ~ 500 Hz, 0.5 Hr / cycle, 4 cycles for each X, Y, Z.

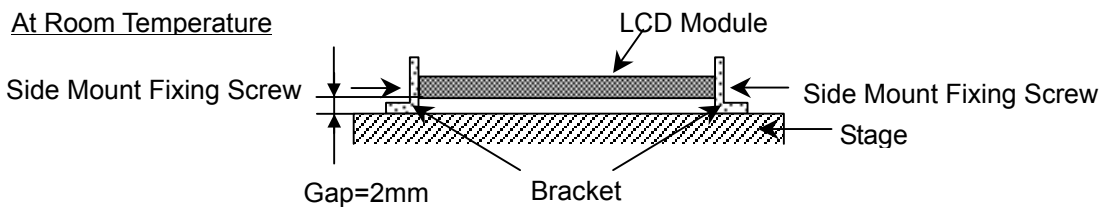

Note (5) At testing Vibration and Shock, the fixture in holding the module has to be hard and rigid enough so that the module would not be twisted or bent by the fixture. The gap between panel and testing table should be less than 2mm.

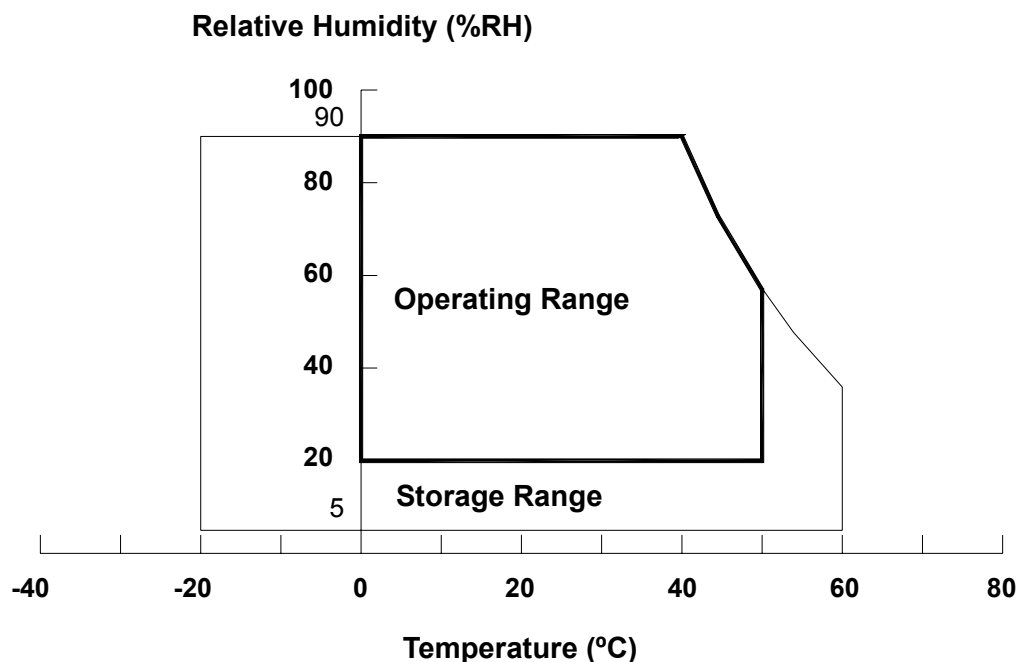

2.2 ELECTRICAL ABSOLUTE RATINGS

2.2.1 TFT LCD MODULE

Item	Symbol	Value		Unit	Note
		Min.	Max.		
Power Supply Voltage	V _{CC}	-0.3	+4.0	V	(1)
Logic Input Voltage	V _{IN}	-0.3	V _{CC} +0.3	V	

2.2.2 BACKLIGHT UNIT

Item	Symbol	Value		Unit	Note
		Min.	Max.		
Lamp Voltage	V _L	-	2.5K	V _{RMS}	(1), (2), I _L = 6.0 mA
Lamp Current	I _L	-	7.5	mA _{RMS}	
Lamp Frequency	F _L	-	80	KHz	(1), (2)

Note (1) Permanent damage to the device may occur if maximum values are exceeded. Function operation should be restricted to the conditions described under Normal Operating Conditions.

Note (2) Specified values are for lamp (Refer to 3.2 for further information).

3. ELECTRICAL CHARACTERISTICS

3.1 TFT LCD MODULE

T_a = 25 ± 2 °C

Parameter	Symbol	Value			Unit	Note
		Min.	Typ.	Max.		
Power Supply Voltage	V _{CC}	3.0	3.3	3.6	V	-
Ripple Voltage	V _{RP}	-	50	-	mV	-
Rush Current	I _{RUSH}	-	-	1.5	A	(2)
Power Supply Current	White	-	400	-	mA	(3)a
	Black	-	600	-	mA	(3)b
Logical Input Voltage	"H" Level	V _{IL}	-	+100	mV	-
	"L" Level	V _{IH}	-100	-	mV	-
Terminating Resistor	R _T	-	100	-	Ohm	-

Note (1) The module should be always operated within above ranges.

Note (2) Measurement Conditions

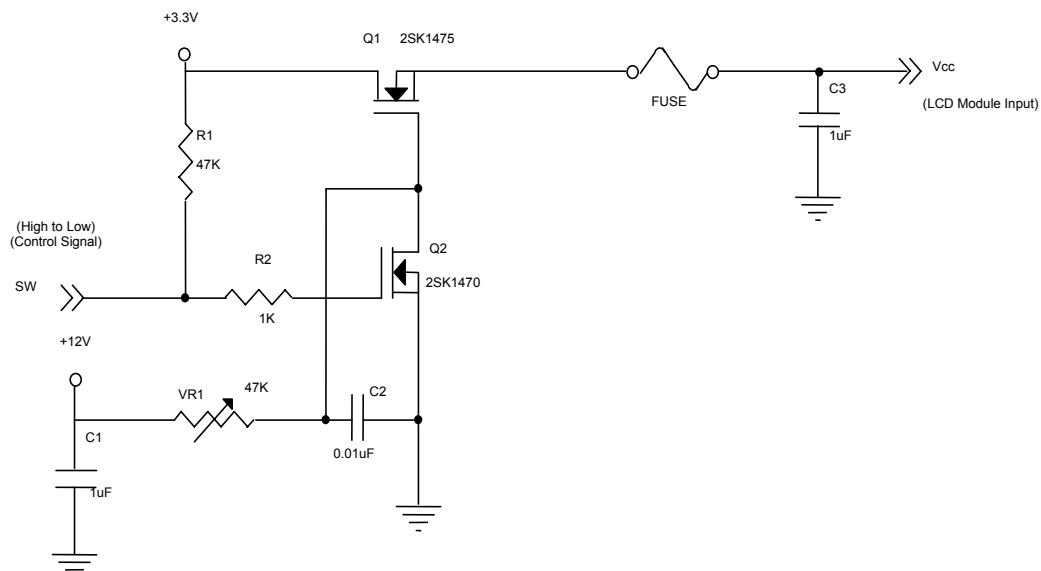

Vcc rising time is 470us

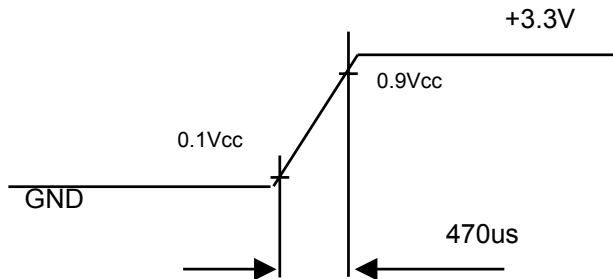

Note (3) The specified power supply current is under the conditions at $V_{cc} = 3.3\text{ V}$, $T_a = 25 \pm 2\text{ }^\circ\text{C}$, $f_v = 60\text{ Hz}$, whereas a power dissipation check pattern below is displayed.

a. White Pattern



Active Area

b. Black Pattern



Active Area

c. Vertical Stripe Pattern

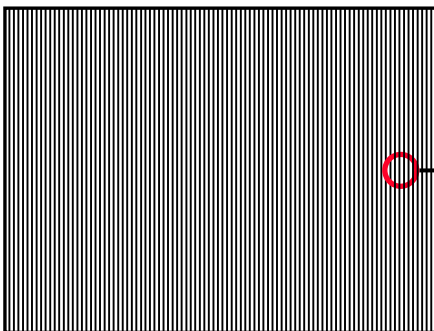

Active Area

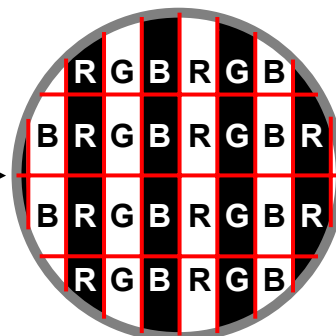

3.2 BACKLIGHT UNIT

Ta = 25 ± 2 °C

Parameter	Symbol	Value			Unit	Note
		Min.	Typ.	Max.		
Lamp Input Voltage	V _L	612	680	748	V _{RMS}	I _L = 6.0 mA
Lamp Current	I _L	2.0	6.0	6.5	mA _{RMS}	(1)
Lamp Turn On Voltage	V _s	-	-	1150 (25 °C)	V _{RMS}	(2)
		-	-	1500 (0 °C)	V _{RMS}	(2)
Operating Frequency	F _L	40	60	80	KHz	(3)
Lamp Life Time	L _{BL}	10,000	15,000	-	Hrs	(5)
Power Consumption	P _L	-	4.08	-	W	(4), I _L = 6.0 mA

Note (1) Lamp current is measured by utilizing a high frequency current meter as shown below:

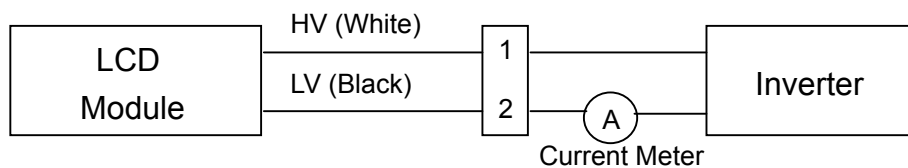

Note (2) The voltage shown above should be applied to the lamp for more than 1 second after startup. Otherwise the lamp may not be turned on.

Note (3) The lamp frequency may produce interference with horizontal synchronous frequency from the display, and this may cause line flow on the display. In order to avoid interference, the lamp frequency should be detached from the horizontal synchronous frequency and its harmonics as far as possible.

Note (4) $P_L = I_L \times V_L$

Note (5) The lifetime of lamp can be defined as the time in which it continues to operate under the condition Ta = 25 ± 2 °C and I_L = 6.0 mA_{RMS} until one of the following events occurs:

- (a) When the brightness becomes or lower than 50% of its original value.
- (b) When the effective ignition length becomes or lower than 80% of its original value. (Effective ignition length is defined as an area that has less than 70% brightness compared to the brightness in the center point.)

Note (6) The waveform of the voltage output of inverter must be area-symmetric and the design of the inverter must have specifications for the modularized lamp. The performance of the Backlight, such as lifetime or brightness, is greatly influenced by the characteristics of the DC-AC inverter for the lamp. All the parameters of an inverter should be carefully designed to avoid producing too much current leakage from high voltage output of the inverter. When designing or ordering the inverter please make sure that a poor lighting caused by the mismatch of the Backlight and the inverter (miss-lighting, flicker, etc.) never occurs. If the above situation is confirmed, the module should be operated in the same manners when it is installed in your instrument.

3.3 EDID DATA

The following data is based on VESA Enhanced EDID proposal.

Byte # (decimal)	Byte # (hex)	Field Name and Comments	Value (hex)	Value (binary)
0	00	Header	00	00000000
1	01	Header	FF	11111111
2	02	Header	FF	11111111
3	03	Header	FF	11111111
4	04	Header	FF	11111111
5	05	Header	FF	11111111
6	06	Header	FF	11111111
7	07	Header	00	00000000
8	08	EISA ID manufacturer name	06	00000110
9	09	EISA ID manufacturer name	10	00010000
10	0A	ID product code	15	00010101
11	0B	ID product code (hex LSB first)	01	00000001
12	0C	ID S/N (fixed "0")	00	00000000
13	0D	ID S/N (fixed "0")	00	00000000
14	0E	ID S/N (fixed "0")	00	00000000
15	0F	ID S/N (fixed "0")	00	00000000
16	10	Week of manufacture (fixed "00")	00	00000000
17	11	Year of manufacture (fixed "2002")	0C	00001100
18	12	EDID structure version # ("1")	01	00000001
19	13	EDID revision # ("3")	03	00000011
20	14	Video I/P definition ("digital")	80	10000000
21	15	Max H image size ("30.4128 cm")	1E	00011110
22	16	Max V image size ("22.8096 cm")	17	00010111
23	17	Display Gamma (Gamma = "2.2")	78	01111000
24	18	Feature support ("Active off, RGB Color")	28	00101000
25	19	Red/Green (Rx1, Rx0, Ry1, Ry0, Gx1, Gx0, Gy1, Gy0)	77	01110111
26	1A	Blue/White (Bx1, Bx0, By1, By0, Wx1, Wx0, Wy1, Wy0)	F1	11110001
27	1B	Red-x (Rx = "0.626")	A0	10100000
28	1C	Red-y (Ry = "0.355")	5A	01011010
29	1D	Green-x (Gx = "0.294")	4B	01001011
30	1E	Green-y (Gy = "0.589")	96	10010110
31	1F	Blue-x (Bx = "0.144")	24	00100100
32	20	Blue-y (By = "0.097")	18	00011000
33	21	White-x (Wx = "0.309")	4F	01001111
34	22	White-y (Wy = "0.329")	54	01010100
35	23	Established timings 1	00	00000000
36	24	Established timings 2 (1024x768@60Hz)	08	00001000
37	25	Manufacturer's reserved timings	00	00000000
38	26	Standard timing ID # 1	01	00000001
39	27	Standard timing ID # 1	01	00000001
40	28	Standard timing ID # 2	01	00000001
41	29	Standard timing ID # 2	01	00000001
42	2A	Standard timing ID # 3	01	00000001
43	2B	Standard timing ID # 3	01	00000001
44	2C	Standard timing ID # 4	01	00000001
45	2D	Standard timing ID # 4	01	00000001
46	2E	Standard timing ID # 5	01	00000001
47	2F	Standard timing ID # 5	01	00000001

Byte # (decimal)	Byte # (hex)	Field Name and Comments	Value (hex)	Value (binary)
48	30	Standard timing ID # 6	01	00000001
49	31	Standard timing ID # 6	01	00000001
50	32	Standard timing ID # 7	01	00000001
51	33	Standard timing ID # 7	01	00000001
52	34	Standard timing ID # 8	01	00000001
53	35	Standard timing ID # 8	01	00000001
54	36	Detailed timing description # 1 Pixel clock ("65 MHz")	64	01100100
55	37	# 1 Pixel clock (hex LSB first)	19	00011001
56	38	# 1 H active ("1024")	00	00000000
57	39	# 1 H blank ("320")	40	01000000
58	3A	# 1 H active : H blank ("1024 : 320")	41	01000001
59	3B	# 1 V active ("768")	00	00000000
60	3C	# 1 V blank ("38")	26	00100110
61	3D	# 1 V active : V blank ("768 : 38")	30	00110000
62	3E	# 1 H sync offset ("24")	18	00011000
63	3F	# 1 H sync pulse width ("136")	88	10001000
64	40	# 1 V sync offset : V sync pulse width ("3 : 6")	36	00110110
65	41	# 1 H sync offset : H sync pulse width : V sync offset : V sync width ("24 : 136 : 3 : 6")	00	00000000
66	42	# 1 H image size ("304.128 mm")	30	00110000
67	43	# 1 V image size ("228.096 mm")	E4	11100100
68	44	# 1 H image size : V image size ("304 : 228")	10	00010000
69	45	# 1 H boarder ("0")	00	00000000
70	46	# 1 V boarder ("0")	00	00000000
71	47	# 1 Flags ("Non-Interlace, Non-Stereo, Digital Separate")	18	00011000
72	48	Detailed timing description # 2	00	00000000
73	49	# 2 Flag	00	00000000
74	4A	# 2 Reserved	00	00000000
75	4B	# 2 FE (hex) defines ASCII string (Model Name "N150X1", ASCII)	FE	11111110
76	4C	# 2 Flag	00	00000000
77	4D	# 2 1 st character of string ("N")	4E	01001110
78	4E	# 2 2 nd character of string ("1")	31	00110001
79	4F	# 2 3 rd character of string ("5")	35	00110101
80	50	# 2 4 th character of string ("0")	30	00110000
81	51	# 2 5 th character of string ("X")	58	01011000
82	52	# 2 6 th character of string ("1")	31	00110001
83	53	# 2 New line character # 2 indicates end of ASCII string	20	00100000
84	54	# 2 Padding with "Blank" character	20	00100000
85	55	# 2 Padding with "Blank" character	20	00100000
86	56	# 2 Padding with "Blank" character	20	00100000
87	57	# 2 Padding with "Blank" character	20	00100000
88	58	# 2 Padding with "Blank" character	20	00100000
89	59	# 2 Padding with "Blank" character	20	00100000
90	5A	Detailed timing description # 3	00	00000000
91	5B	# 3 Flag	00	00000000
92	5C	# 3 Reserved	00	00000000
93	5D	# 3 FE (hex) defines ASCII string (Model Name "N150X1", ASCII)	FE	11111110
94	5E	# 3 Flag	00	00000000
95	5F	# 3 1 st character of string ("N")	4E	01001110
96	60	# 3 2 nd character of string ("1")	31	00110001
97	61	# 3 3 rd character of string ("5")	35	00110101
98	62	# 3 4 th character of string ("0")	30	00110000

Byte # (decimal)	Byte # (hex)	Field Name and Comments	Value (hex)	Value (binary)
99	63	# 3 5 th character of string ("X")	58	01011000
100	64	# 3 6 th character of string ("1")	31	00110001
101	65	# 3 New line character # 3 indicates end of ASCII string	20	00100000
102	66	# 3 Padding with "Blank" character	20	00100000
103	67	# 3 Padding with "Blank" character	20	00100000
104	68	# 3 Padding with "Blank" character	20	00100000
105	69	# 3 Padding with "Blank" character	20	00100000
106	6A	# 3 Padding with "Blank" character	20	00100000
107	6B	# 3 Padding with "Blank" character	20	00100000
108	6C	Detailed timing description # 4	00	00000000
109	6D	# 4 Flag	00	00000000
110	6E	# 4 Reserved	00	00000000
111	6F	# 4 FC (hex) defines Monitor name ("Color LCD", ASCII)	FC	11111100
112	70	# 4 Flag	00	00000000
113	71	# 4 1 st character of name ("C")	43	01000011
114	72	# 4 2 nd character of name ("o")	6F	01101111
115	73	# 4 3 rd character of name ("l")	6C	01101100
116	74	# 4 4 th character of name ("o")	6F	01101111
117	75	# 4 5 th character of name ("r")	72	01110010
118	76	# 4 6 th character of name (<space>)	20	00100000
119	77	# 4 7 th character of name ("L")	4C	01001100
120	78	# 4 8 th character of name ("C")	43	01000011
121	79	# 4 9 th character of name ("D")	44	01000100
122	7A	# 4 New line character # 4 indicates end of Monitor name	0A	00001010
123	7B	# 4 Padding with "Blank" character	20	00100000
124	7C	# 4 Padding with "Blank" character	20	00100000
125	7D	# 4 Padding with "Blank" character	20	00100000
126	7E	Extension flag	00	00000000
127	7F	Checksum	DD	11011101

4. BLOCK DIAGRAM

4.1 TFT LCD MODULE

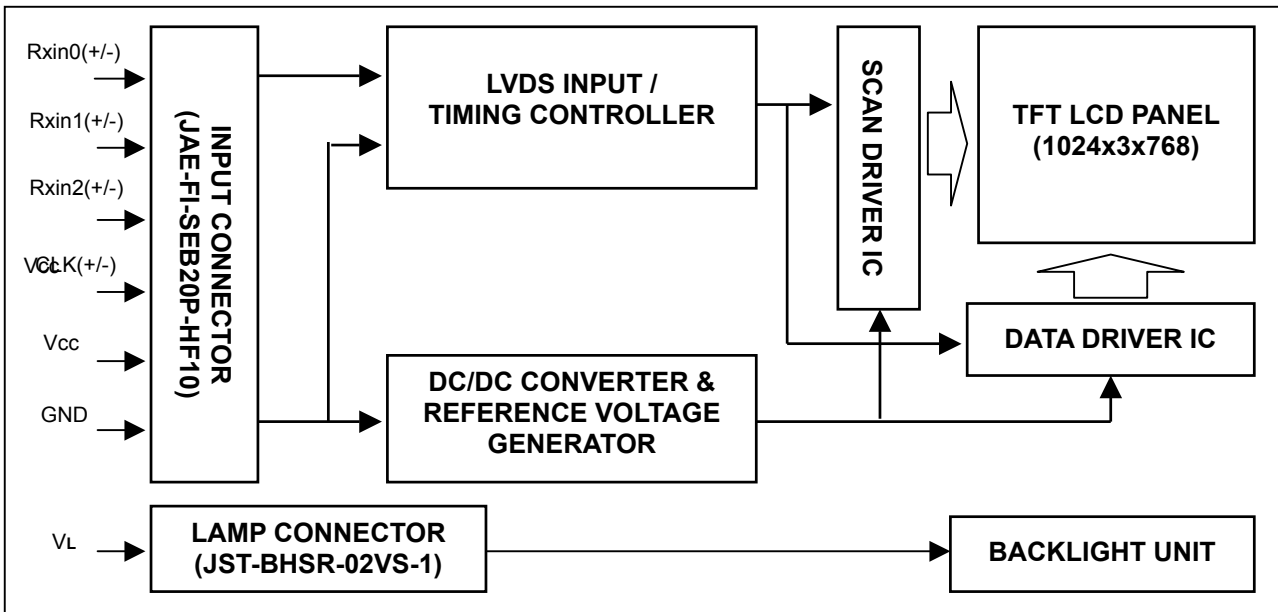

4.2 BACKLIGHT UNIT

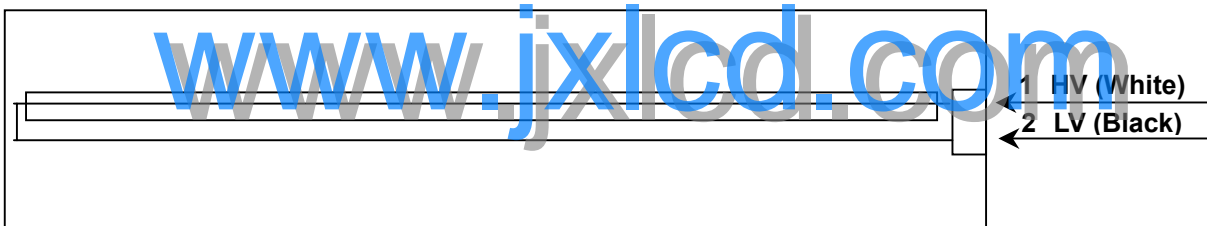

5. INPUT TERMINAL PIN ASSIGNMENT

5.1 TFT LCD MODULE

Pin	Symbol	Description	Polarity	Remark
1	Vcc	Power Supply +3.3 V		-
2	Vcc	Power Supply +3.3 V		-
3	Vss	Ground		-
4	Vss	Ground		-
5	Rxin0-	LVDS Differential Data Input	Negative	R0~R5,G0
6	Rxin0+	LVDS Differential Data Input	Positive	
7	Vss	Ground		-
8	Rxin1-	LVDS Differential Data Input	Negative	G1~G5,B0,B1
9	Rxin1+	LVDS Differential Data Input	Positive	
10	Vss	Ground		-
11	Rxin2-	LVDS Differential Data Input	Negative	B2~B5,DE,Hsync,Vsync
12	Rxin2+	LVDS Differential Data Input	Positive	
13	Vss	Ground		-
14	CLK-	LVDS Clock Data Input	Negative	LVDS Level
15	CLK+	LVDS Clock Data Input	Positive	
16	Vss	Ground		-
17	VEDID	3.3V Power		-
18	NC	Non-Connection		-
19	CLKEDID	DDC Clock		-
20	DATAEDID	DDC Data		-

Note (1) Connector Part No.: JAE-FI-SEB20P-HF10 or equivalent

Note (2) User's connector Part No: JAE-FI-S020S or equivalent

Note (3) The first pixel is even.

www.jxlcd.com

5.2 BACKLIGHT UNIT

Pin	Symbol	Description	Color
1	HV	High Voltage	White
2	LV	Ground	Black

Note (1) Connector Part No.: JST-BHTR-02VS-1 or equivalent

Note (2) User's connector Part No.: JST-SM02B-BHTS-B-TB or equivalent

5.3 TIMING DIAGRAM OF LVDS INPUT SIGNAL

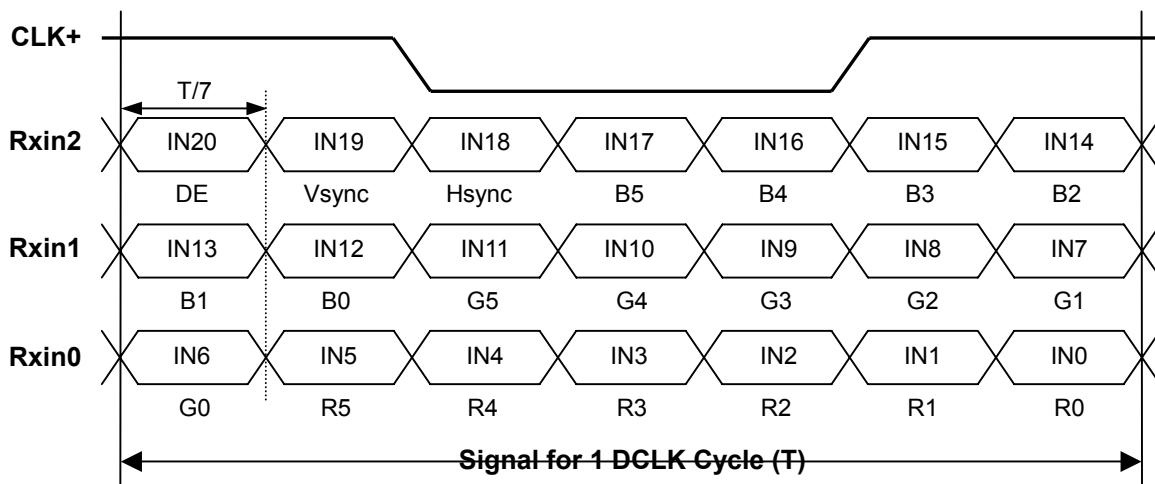

5.4 COLOR DATA INPUT ASSIGNMENT

The brightness of each primary color (red, green and blue) is based on the 6-bit gray scale data input for the color. The higher the binary input, the brighter the color. The table below provides the assignment of color versus data input.

Color		Data Signal																	
		Red						Green						Blue					
		R5	R4	R3	R2	R1	R0	G5	G4	G3	G2	G1	G0	B5	B4	B3	B2	B1	B0
Basic Colors	Black	0	0	0	0	0	0	0	0	0	0	0	0	0	0	0	0	0	0
	Red	1	1	1	1	1	1	0	0	0	0	0	0	0	0	0	0	0	0
	Green	0	0	0	0	0	0	1	1	1	1	1	1	0	0	0	0	0	0
	Blue	0	0	0	0	0	0	0	0	0	0	0	0	1	1	1	1	1	1
	Cyan	0	0	0	0	0	0	1	1	1	1	1	1	1	1	1	1	1	1
	Magenta	1	1	1	1	1	1	0	0	0	0	0	0	1	1	1	1	1	1
	Yellow	1	1	1	1	1	1	1	1	1	1	1	1	0	0	0	0	0	0
	White	1	1	1	1	1	1	1	1	1	1	1	1	1	1	1	1	1	1
Gray Scale Of Red	Red(0)/Dark	0	0	0	0	0	0	0	0	0	0	0	0	0	0	0	0	0	0
	Red(1)	0	0	0	0	0	1	0	0	0	0	0	0	0	0	0	0	0	0
	Red(2)	0	0	0	0	1	0	0	0	0	0	0	0	0	0	0	0	0	0
	⋮	⋮	⋮	⋮	⋮	⋮	⋮	⋮	⋮	⋮	⋮	⋮	⋮	⋮	⋮	⋮	⋮	⋮	⋮
	⋮	⋮	⋮	⋮	⋮	⋮	⋮	⋮	⋮	⋮	⋮	⋮	⋮	⋮	⋮	⋮	⋮	⋮	⋮
	⋮	⋮	⋮	⋮	⋮	⋮	⋮	⋮	⋮	⋮	⋮	⋮	⋮	⋮	⋮	⋮	⋮	⋮	⋮
	Red(61)	1	1	1	1	0	1	0	0	0	0	0	0	0	0	0	0	0	0
	Red(62)	1	1	1	1	1	0	0	0	0	0	0	0	0	0	0	0	0	0
Red(63)	1	1	1	1	1	1	0	0	0	0	0	0	0	0	0	0	0	0	
Gray Scale Of Green	Green(0)/Dark	0	0	0	0	0	0	0	0	0	0	0	0	0	0	0	0	0	0
	Green(1)	0	0	0	0	0	0	0	0	0	0	0	1	0	0	0	0	0	0
	Green(2)	0	0	0	0	0	0	0	0	0	0	1	0	0	0	0	0	0	0
	⋮	⋮	⋮	⋮	⋮	⋮	⋮	⋮	⋮	⋮	⋮	⋮	⋮	⋮	⋮	⋮	⋮	⋮	⋮
	⋮	⋮	⋮	⋮	⋮	⋮	⋮	⋮	⋮	⋮	⋮	⋮	⋮	⋮	⋮	⋮	⋮	⋮	⋮
	⋮	⋮	⋮	⋮	⋮	⋮	⋮	⋮	⋮	⋮	⋮	⋮	⋮	⋮	⋮	⋮	⋮	⋮	⋮
	Green(61)	0	0	0	0	0	1	1	1	1	1	0	1	0	0	0	0	0	0
	Green(62)	0	0	0	0	0	1	1	1	1	1	0	0	0	0	0	0	0	0
Green(63)	0	0	0	0	0	1	1	1	1	1	1	1	0	0	0	0	0	0	
Gray Scale Of Blue	Blue(0)/Dark	0	0	0	0	0	0	0	0	0	0	0	0	0	0	0	0	0	0
	Blue(1)	0	0	0	0	0	0	0	0	0	0	0	0	0	0	0	0	0	1
	Blue(2)	0	0	0	0	0	0	0	0	0	0	0	0	0	0	0	0	1	0
	⋮	⋮	⋮	⋮	⋮	⋮	⋮	⋮	⋮	⋮	⋮	⋮	⋮	⋮	⋮	⋮	⋮	⋮	⋮
	⋮	⋮	⋮	⋮	⋮	⋮	⋮	⋮	⋮	⋮	⋮	⋮	⋮	⋮	⋮	⋮	⋮	⋮	⋮
	⋮	⋮	⋮	⋮	⋮	⋮	⋮	⋮	⋮	⋮	⋮	⋮	⋮	⋮	⋮	⋮	⋮	⋮	⋮
	Blue(61)	0	0	0	0	0	0	0	0	0	0	0	1	1	1	1	1	0	1
	Blue(62)	0	0	0	0	0	0	0	0	0	0	0	1	1	1	1	1	1	0
Blue(63)	0	0	0	0	0	0	0	0	0	0	0	1	1	1	1	1	1	1	

Note (1) 0: Low Level Voltage, 1: High Level Voltage

6. INTERFACE TIMING

6.1 INPUT SIGNAL TIMING SPECIFICATIONS

The input signal timing specifications are shown as the following table and timing diagram.

Signal	Item	Symbol	Min.	Typ.	Max.	Unit	Note
DCLK	Frequency	1/Tc	20	65	68	MHz	-
DE	Frame Time Cycle	TV	771	806	850	TH	-
	Vertical Active Display Period	TVD	768	768	768	TH	-
	One Line Scanning Time Cycle	TH	1200	1344	1600	Tc	-
	Horizontal Active Display Period	THD	1024	1024	1024	Tc	-

Note (1) Because this module is operated by DE only mode, Hsync and Vsync input signals should be set to low logic level or ground. Otherwise, this module would operate abnormally.

INPUT SIGNAL TIMING DIAGRAM

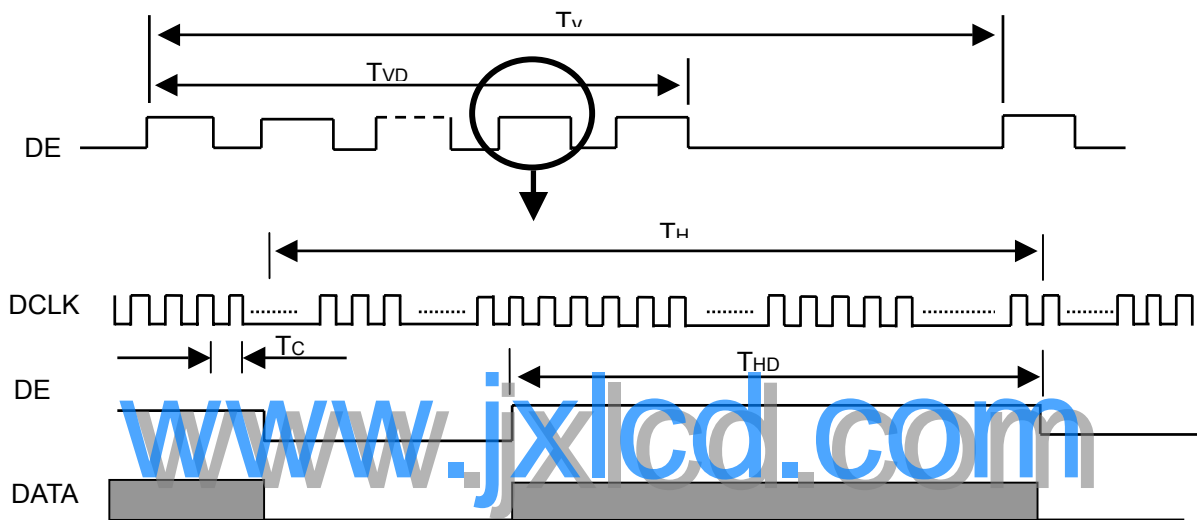

6.2 POWER ON/OFF SEQUENCE

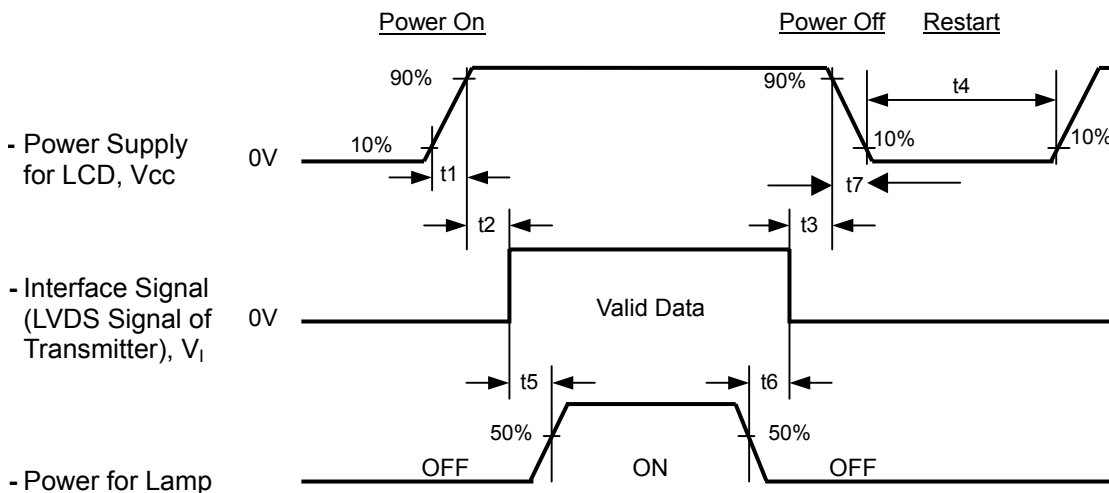

Timing Specifications:

$$0 < t1 \leq 10 \text{ msec}$$

$$0 < t2 \leq 50 \text{ msec}$$

$$0 < t3 \leq 50 \text{ msec}$$

$$t4 \geq 200 \text{ msec}$$

$$t5 \geq 200 \text{ msec}$$

$$t6 \geq 5 \text{ msec}$$

$$0 \leq t7 \leq 50 \text{ msec (given by system)}$$

$$0 \leq t7 \leq 400 \text{ msec (measured on TFT-LCD module)}$$

Note (1) Please avoid floating state of interface signal at invalid period.

Note (2) When the interface signal is invalid, be sure to pull down the power supply of LCD Vcc to 0 V.

Note (3) The Backlight inverter power must be turned on after the power supply for the logic and the interface signal is valid. The Backlight inverter power must be turned off before the power supply for the logic and the interface signal is invalid.

www.jxlcd.com

7. OPTICAL CHARACTERISTICS

7.1 TEST CONDITIONS

Item	Symbol	Value	Unit
Ambient Temperature	T _a	25±2	°C
Ambient Humidity	H _a	50±10	%RH
Supply Voltage	V _{CC}	3.3	V
Input Signal	According to typical value in "3. ELECTRICAL CHARACTERISTICS"		
Inverter Current	I _L	6.0	mA
Inverter Driving Frequency	F _L	60	KHz
Inverter	Sumida H05-4915		

The relative measurement methods of optical characteristics are shown in 6.2. The following items should be measured under the test conditions described in 6.1 and stable environment shown in Note (6).

7.2 OPTICAL SPECIFICATIONS

Item	Symbol	Condition	Min.	Typ.	Max.	Unit	Note	
Contrast Ratio	CR	θ _x =0°, θ _y =0° Viewing Normal Angle	150	250	-	-	(2), (6)	
Response Time	T _R		-	6.0	10.0	ms	(3)	
	T _F		-	17.0	25.0	ms		
Center Luminance of White	L		170	200	-	cd/m ²	(6)	
Average Luminance of White	L _{AVE}		150	180	-	cd/m ²	(4), (6)	
White Variation	δW _A		70	-	-	%	(6), (8)	
	δW _B		70	-	-	%		
Cross Talk	CT		-	-	3.0	%	(5), (6)	
Color Chromaticity	Red		F _x	0.597	0.627	0.657	-	(1), (6)
			R _y	0.323	0.353	0.383	-	
	Green	G _x	0.268	0.298	0.328	-		
		G _y	0.556	0.586	0.616	-		
	Blue	B _x	0.115	0.145	0.175	-		
		B _y	0.066	0.096	0.126	-		
	White	W _x	0.283	0.313	0.343	-		
	W _y	0.299	0.329	0.359	-			
Color Gamut	C.G%	50	60	-	%	(9)		
Viewing Angle	Horizontal	θ _{x+}	40	45	-	Deg.	(1), (6)	
		θ _{x-}	40	45	-			
	Vertical	θ _{y+}	10	15	-			
		θ _{y-}	30	35	-			
Surface Reflection Ratio	S _R	-	1.8	2.0	%	(10)		

Note (1) Definition of Viewing Angle (θ_x, θ_y):

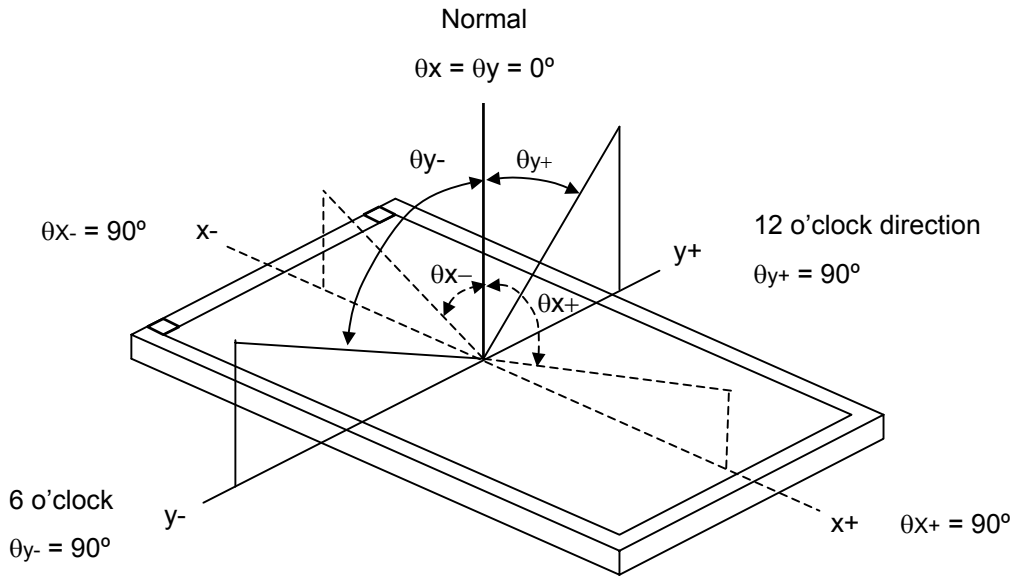

Note (2) Definition of Contrast Ratio (CR):

The contrast ratio can be calculated by the following expression.

$$\text{Contrast Ratio (CR)} = L_{63} / L_0$$

L63: Luminance of gray level 63

L0: Luminance of gray level 0

$$\text{CR} = \text{CR} (5)$$

CR (X) is corresponding to the Contrast Ratio of the point X at Figure in Note (7).

Note (3) Definition of Response Time (T_R, T_F):

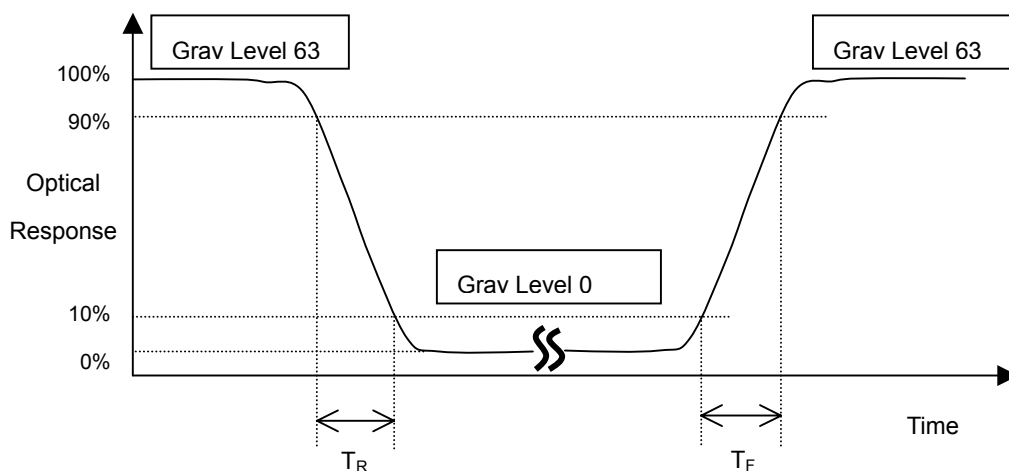

Note (4) Definition of Average Luminance of White (L_{AVE}):

Measure the luminance of gray level 63 at 5 points

$$L_{AVE} = [L(1) + L(2) + L(3) + L(4) + L(5)] / 5$$

$L(x)$ is corresponding to the luminance of the point X at Figure in Note (7).

Note (5) Definition of Cross Talk (CT):

$$CT = |Y_B - Y_A| / Y_A \times 100 (\%)$$

Where:

Y_A = Luminance of measured location without gray level 0 pattern (cd/m^2)

Y_B = Luminance of measured location with gray level 0 pattern (cd/m^2)

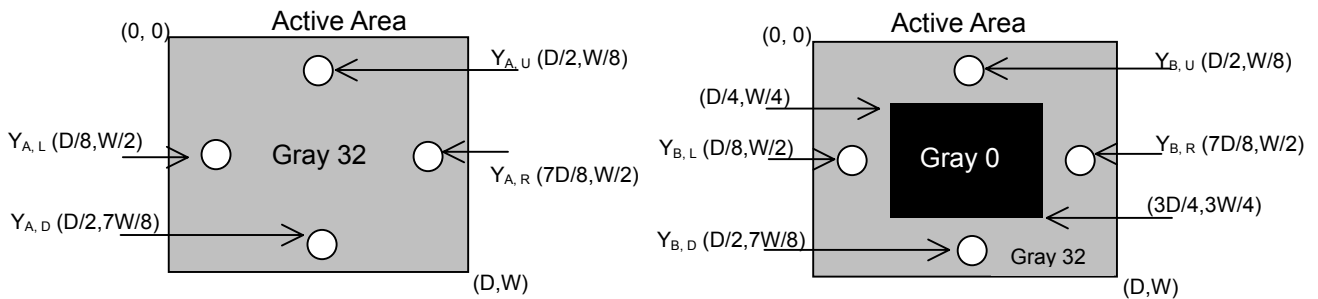

www.jxlcd.com

Note (6) Measurement Setup:

The LCD module should be stabilized at given temperature for 20 minutes to avoid abrupt temperature change during measuring. In order to stabilize the luminance, the measurement should be executed after lighting Backlight for 20 minutes in a windless room.

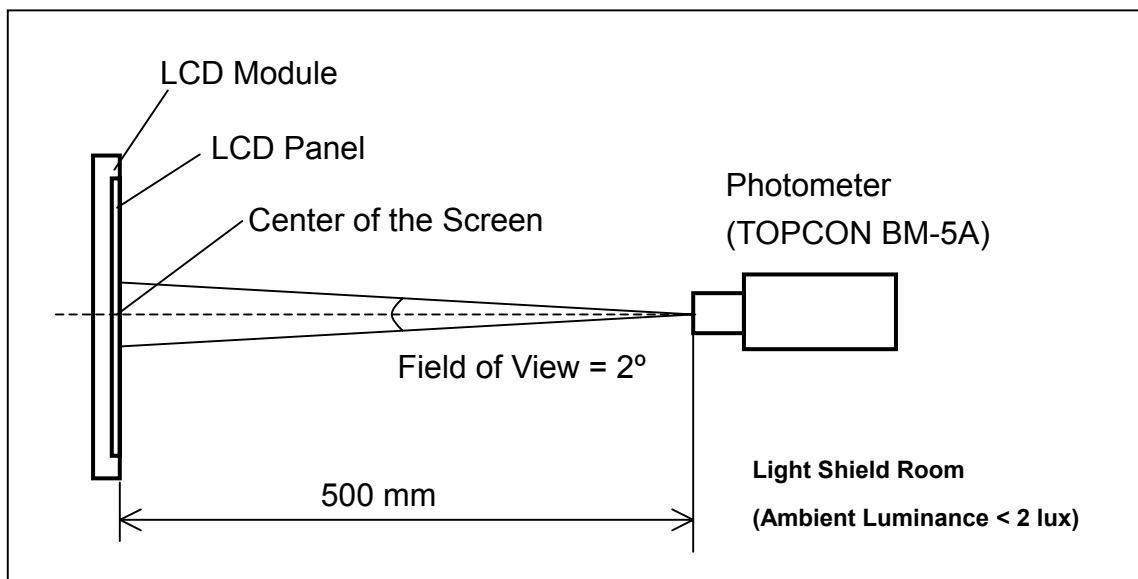

Note (7) Definition of White Variation (δW):

Measure the luminance of gray level 63 at 5 points

$$\delta W = \text{Maximum [L (1), L (2), L (3), L (4), L (5)]} / \text{Minimum [L (1), L (2), L (3), L (4), L (5)]}$$

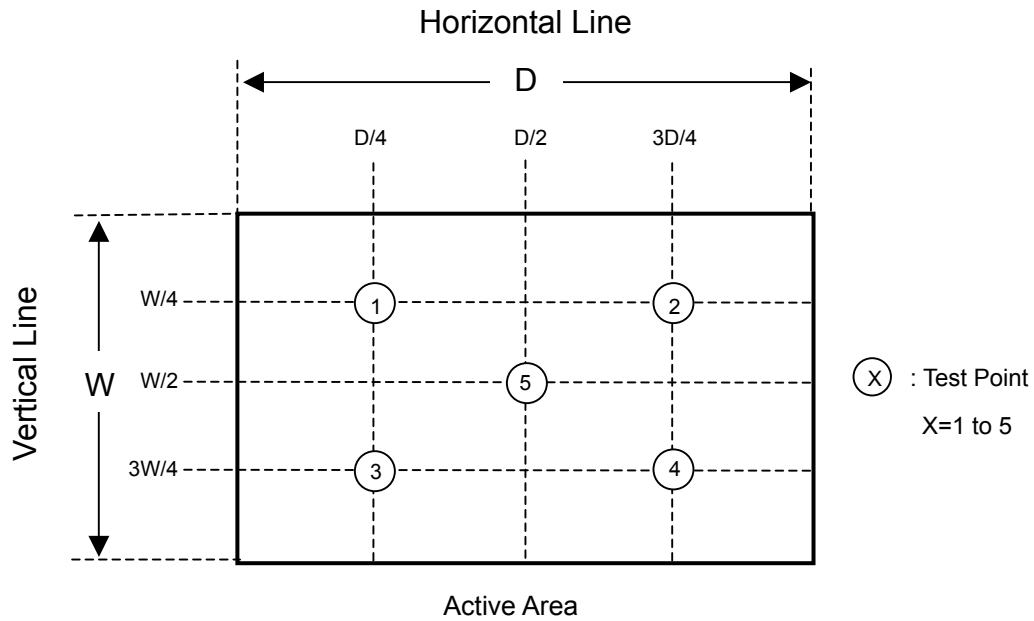

Note (8) Definition of White Variation (δW_A):

Measure the luminance of gray level 63 at any point of range A on active display area

$$\delta W_A = \text{Minimum [L(Any point of area A)]} / \text{Maximum [L(Any point of area A)]} * 100 \%$$

Definition of White Variation (δW_B):

Measure the luminance of gray level 63 at any point of range B on active display area

$$\delta W_B = \text{Minimum [L(Any point of area B)]} / \text{Maximum [L(Any point of area B)]} * 100 \%$$

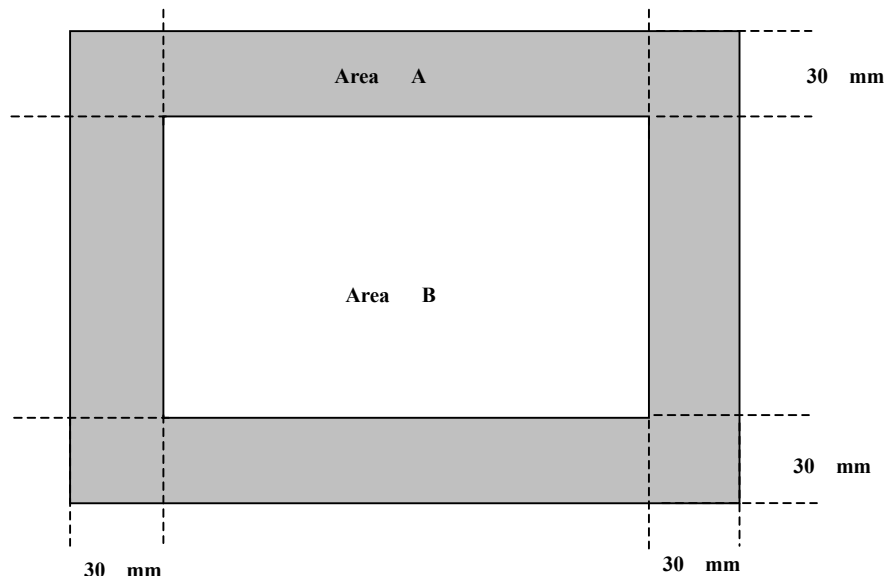

Note (9) Definition of color gamut (C.G%):

$$C.G\% = \Delta R G B / \Delta R_0 G_0 B_0,$$

R_0, G_0, B_0 : color coordinates of red, green, and blue defined by NTSC, respectively.

R, G, B : color coordinates of module on 255 gray levels of red, green, and blue, respectively.

$\Delta R_0 G_0 B_0$: area of triangle defined by R_0, G_0, B_0

$\Delta R G B$: area of triangle defined by R, G, B

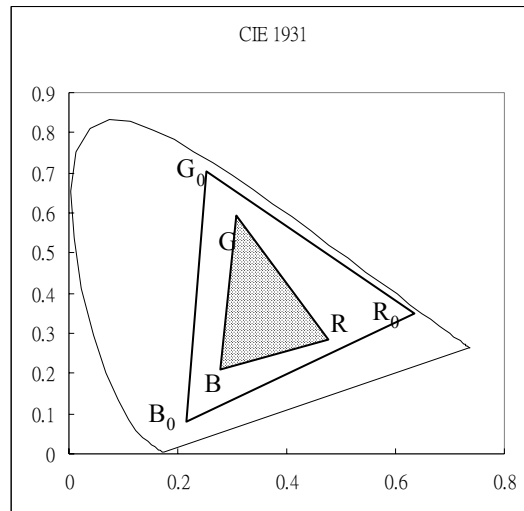

www.jxlcd.com

Note (10) Definition of Surface Reflection Ratio (S_R):

The spec was from the approval sheets of polarizer.

8. DEFINITION OF LABELS

8.1 CMO MODULE LABEL

The barcode nameplate is pasted on each module as illustration, and its definitions are as following explanation.

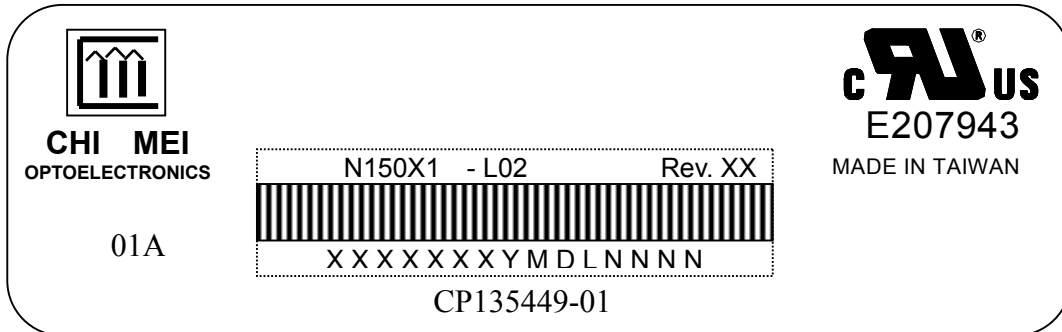

(a) Model Name: **N150X1** - L02

Sub-Model Name for Sub-Model version control

Model Name (For Safety Application, please uses this module name. Sub-Module Name may be changed)

(b) Revision: Rev. XX, for example: A0, A1... B1, B2... or C1, C2...etc.

(c) Serial ID: XXXXXXXYMDLNNNN

Serial No.

Product Line

Year, Month, Date

CMO Internal Use

CMO Internal Use

Revision

CMO Internal Use

(d) Fujitsu product code: CP135449-01

(e) Fujitsu revision no.:01A,02A,.....etc

Serial ID includes the information as below:

(a) Manufactured Date: Year: 1~9, for 2001~2009

Month: 1~9, A~C, for Jan. ~ Dec.

Day: 1~9, A~Y, for 1st to 31st, exclude I,O and U.

(b) Revision Code: Cover all the change

(c) Serial No.: Manufacturing sequence of product

(d) Product Line: 1 -> Line1, 2 -> Line 2, A -> Line A ...etc.

8.2 Carton Label

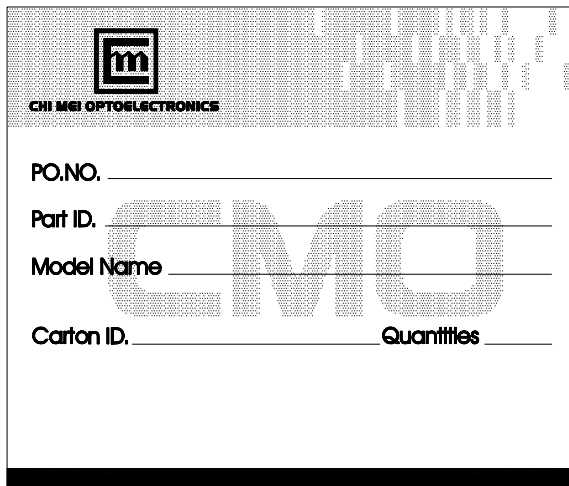

CHI MEI OPTOELECTRONICS

PO.NO. _____

Part ID. _____

Model Name _____

Carton ID. _____ Quantities _____

9. Packing

9.1 Carton

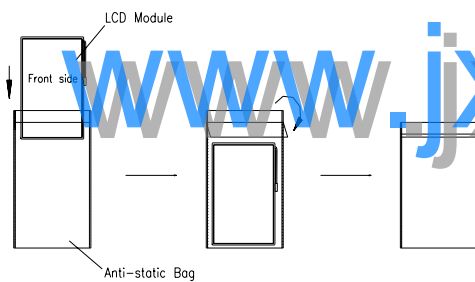

Box dimensions: 422(L)x337(W)x345(H)mm
 Weight: Approx. 8.5Kg(10modules per 1 box)

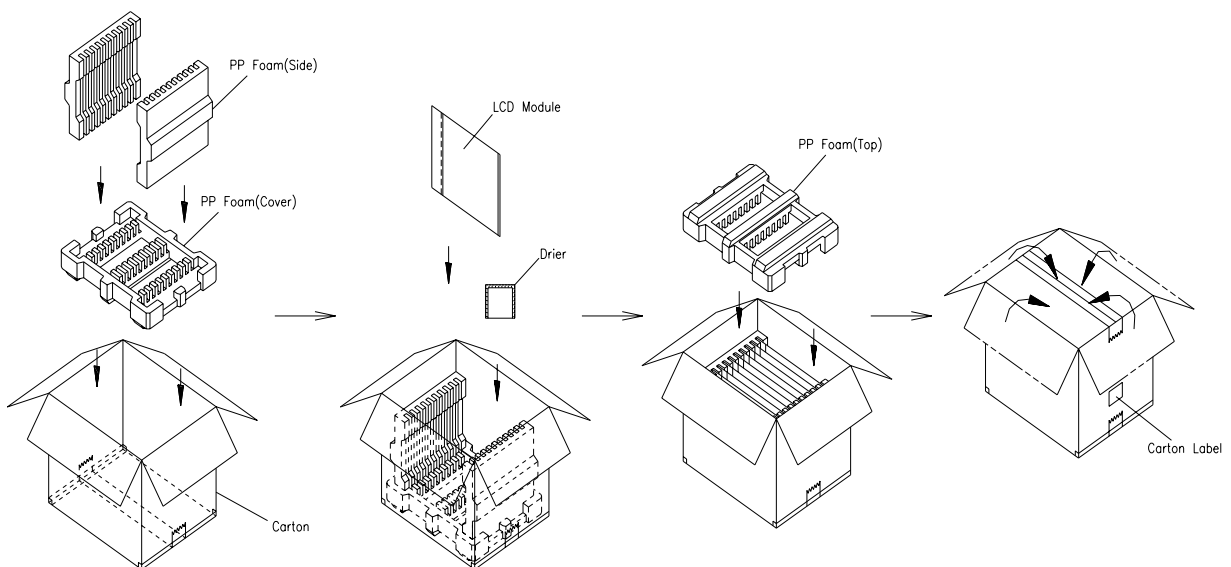

9.2 Pallet

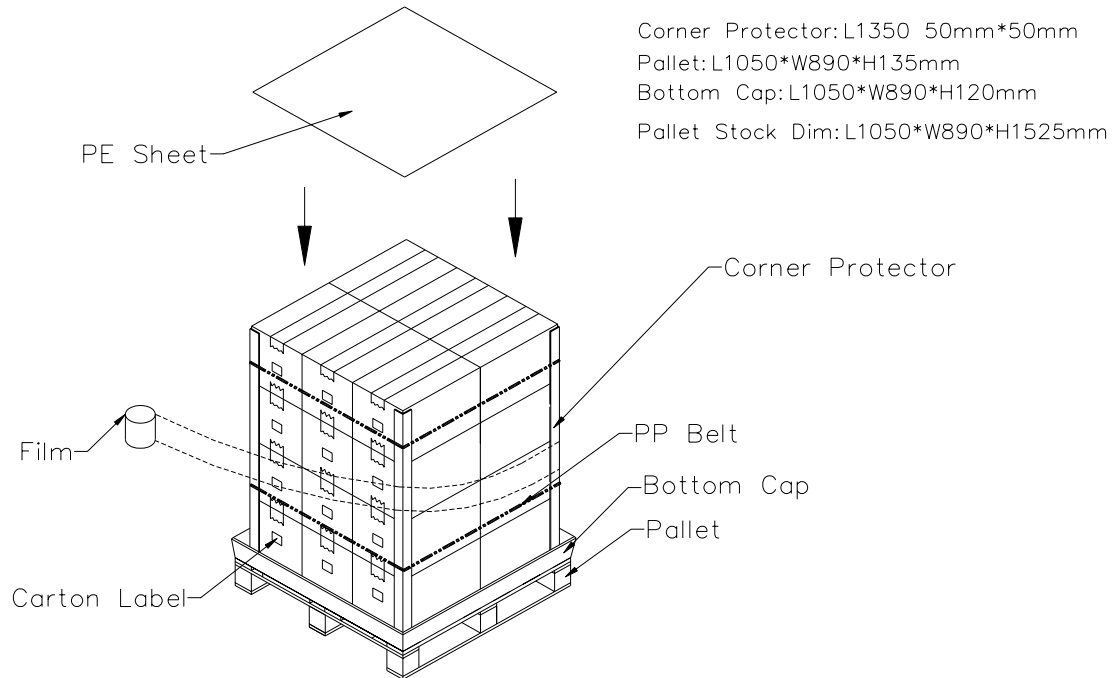

www.jxlcd.com

10. PRECAUTIONS

10.1 ASSEMBLY AND HANDLING PRECAUTIONS

- (1) Do not apply rough force such as bending or twisting to the module during assembly.
- (2) To assemble or install module into user's system can be only in clean working areas. The dust and oil may cause electrical short or worsen the polarizer.
- (3) It's not permitted to have pressure or impulse on the module because the LCD panel and Backlight will be damaged.
- (4) Always follow the correct power sequence when LCD module is connecting and operating. This can prevent damage to the CMOS LSI chips during latch-up.
- (5) Do not pull the I/F connector in or out while the module is operating.
- (6) Do not disassemble the module.
- (7) Use a soft dry cloth without chemicals for cleaning, because the surface of polarizer is very soft and easily scratched.
- (8) It is dangerous that moisture come into or contacted the LCD module, because moisture may damage LCD module when it is operating.
- (9) High temperature or humidity may reduce the performance of module. Please store LCD module within the specified storage conditions.
- (10) When ambient temperature is lower than 10°C may reduce the display quality. For example, the response time will become slowly, and the starting voltage of CCFL will be higher than room temperature.

www.jxlcd.com

10.2 SAFETY PRECAUTIONS

- (1) The startup voltage of Backlight is approximately 1000 Volts. It may cause electrical shock while assembling with inverter. Do not disassemble the module or insert anything into the Backlight unit.
- (2) If the liquid crystal material leaks from the panel, it should be kept away from the eyes or mouth. In case of contact with hands, skin or clothes, it has to be washed away thoroughly with soap.
- (3) After the module's end of life, it is not harmful in case of normal operation and storage.

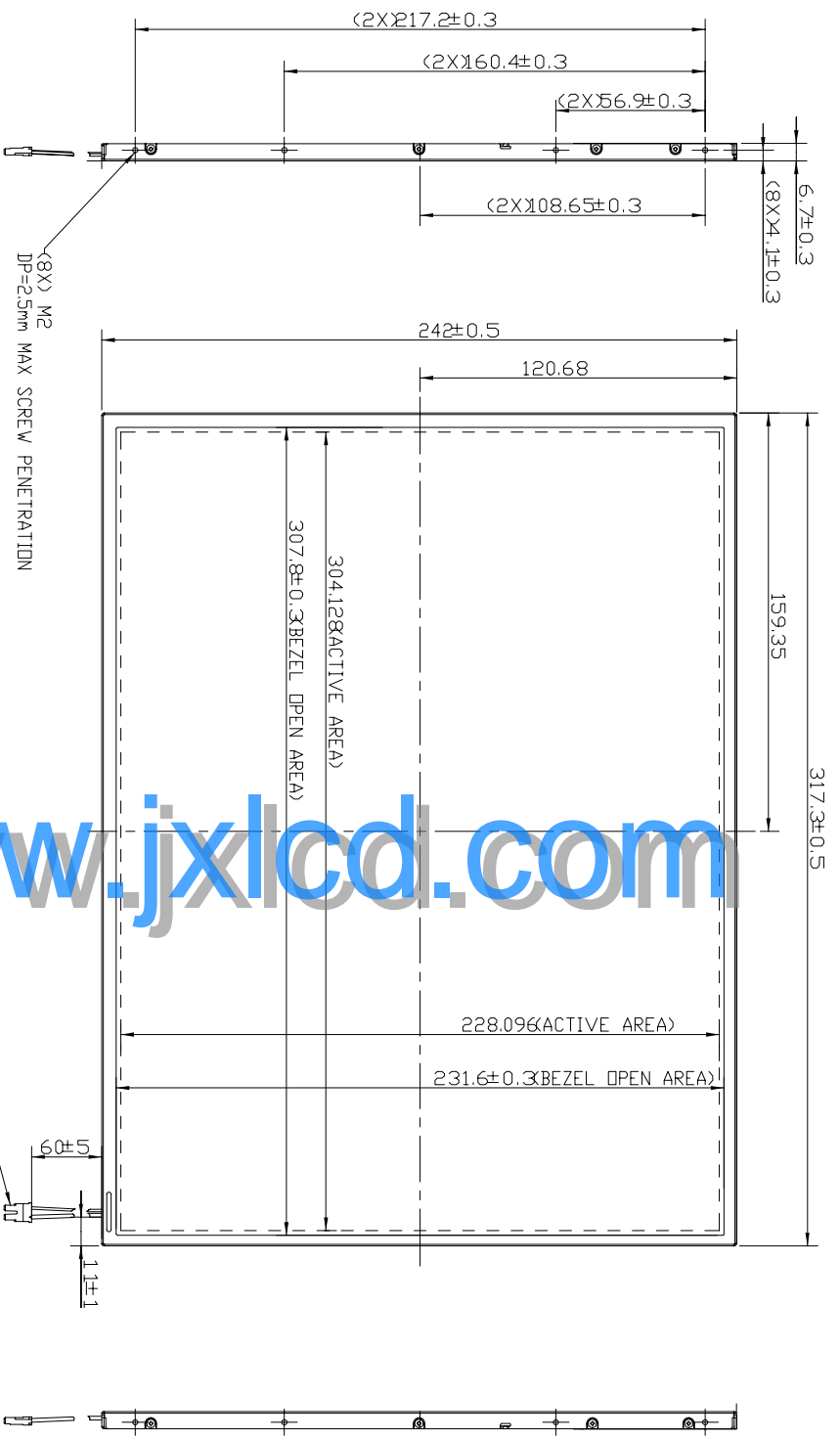

NOTES:
 1.GENERAL TOLERANCE:±0.5,
 2.SCREW TORQUE FOR MOUNTING SHALL NOT EXCEED 2.0kgf-cm.

www.jxlcd.com

CHI MEI
 OPTOELECTRONICS CORP. 奇美電子股份有限公司

APPROVED: DWG NO.: N150241031
 CHECKED: DATE: 05/06/2002

DESIGNER: WANG,CHIEH-KUEN PART NO.:
 DRAWER: WANG,CHIEH-KUEN REV.: 1 UNIT: SCALE: SHEET:

TITLE: OUTLINE N150X1 MM 1/2 1/2

©CHI MEI® COPYRIGHT 2002. ALL RIGHTS RESERVED. COPYING FORBIDDEN.

MARK	DESCRIPTION	DATE	CHANGE BY	APPROVAL BY	ECN NO.
8					
7					
6					
5					
4					
3					
2					
1					

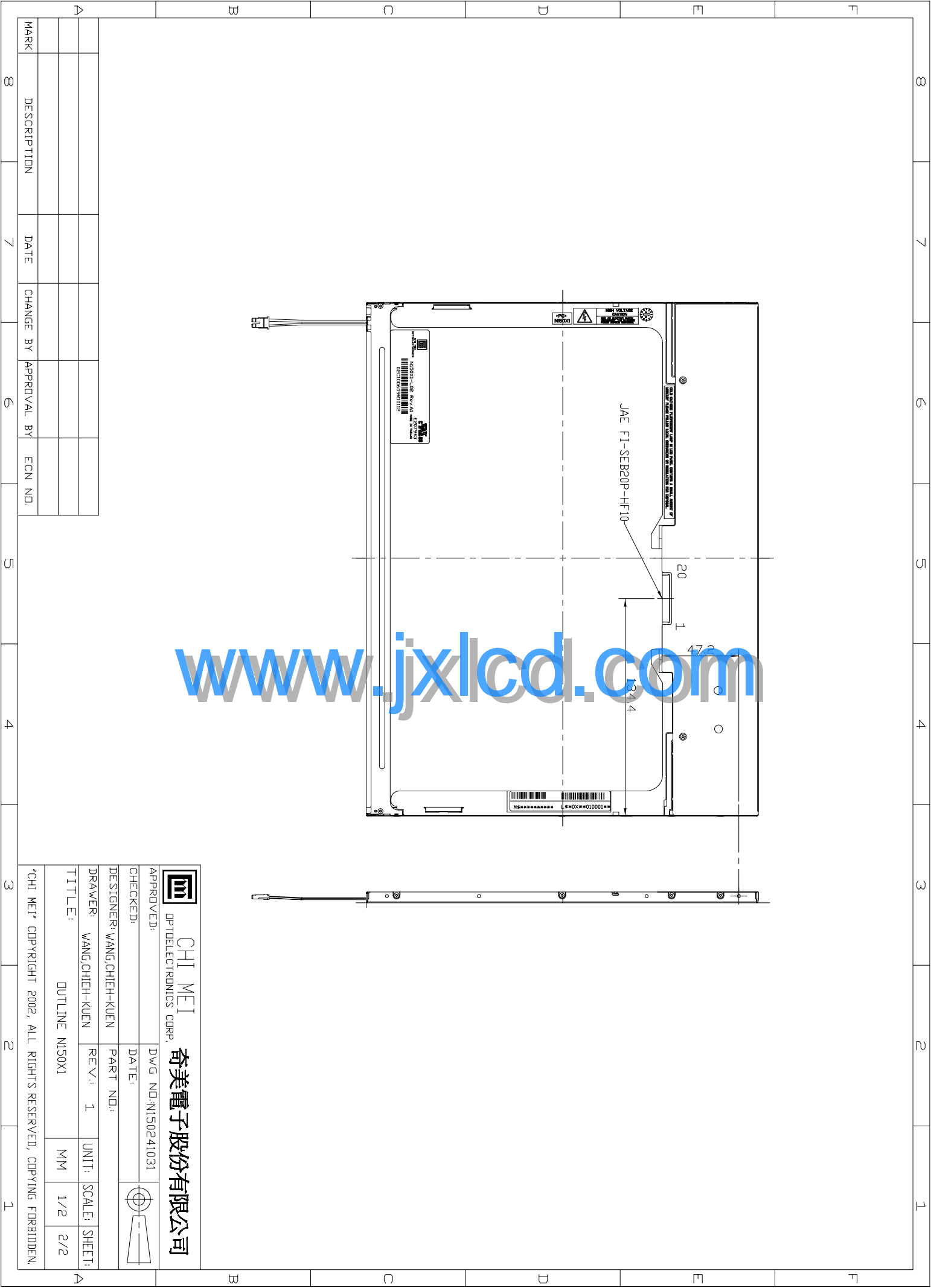

MARK	DESCRIPTION	DATE	CHANGE BY	APPROVAL BY	ECN NO.
8					
7					
6					
5					
4					
3					
2					
1					

CHI MEI
 OPTOELECTRONICS CORP. **奇美電子股份有限公司**

APPROVED: DWG NO.: N150241031

CHECKED: DATE:

DESIGNER: WANG,CHIEH-KUEN PART NO.:

DRAWER: WANG,CHIEH-KUEN REV.: 1 UNIT: MM SCALE: 1/2 SHEET: 2/2

TITLE: OUTLINE N150X1

©CHI MEI® COPYRIGHT 2002, ALL RIGHTS RESERVED, COPYING FORBIDDEN.