

## TFT LCD Tentative Specification

**MODEL NO.: N150X2-L02**

[www.jxlcd.com](http://www.jxlcd.com)

Liquid Crystal Display Division		
QRA Dept.	PDD II Dept.	PD Dept.
Approval	Approval	Approval
		

- CONTENTS -

REVISION HISTORY	-----	3
1. GENERAL DESCRIPTION	-----	4
1.1 OVERVIEW		
1.2 FEATURES		
1.3 APPLICATION		
1.4 GENERAL SPECIFICATIONS		
1.5 MECHANICAL SPECIFICATIONS		
2. ABSOLUTE MAXIMUM RATINGS	-----	5
2.1 ABSOLUTE RATINGS OF ENVIRONMENT		
2.2 ELECTRICAL ABSOLUTE RATINGS		
2.2.1 TFT LCD MODULE		
2.2.2 BACKLIGHT UNIT		
3. ELECTRICAL CHARACTERISTICS	-----	6
3.1 TFT LCD MODULE		
3.2 BACKLIGHT UNIT		
4. BLOCK DIAGRAM	-----	9
4.1 TFT LCD MODULE		
4.2 BACKLIGHT UNIT		
5. INPUT TERMINAL PIN ASSIGNMENT	-----	9
5.1 TFT LCD MODULE		
5.2 BACKLIGHT UNIT		
5.3 TIMING DIAGRAM OF LVDS INPUT SIGNAL		
5.4 COLOR DATA INPUT ASSIGNMENT		
6. INTERFACE TIMING	-----	11
6.1 INPUT SIGNAL TIMING SPECIFICATIONS		
6.2 POWER ON/OFF SEQUENCE		
7. OPTICAL CHARACTERISTICS	-----	14
7.1 TEST CONDITIONS		
7.2 OPTICAL SPECIFICATIONS		
8. PRECAUTIONS	-----	17
8.1 ASSEMBLY AND HANDLING PRECAUTIONS		
8.2 SAFETY PRECAUTIONS		
9. DEFINITION OF LABELS	-----	18
9.1 CMO MODULE LABEL		

[www.jxlcd.com](http://www.jxlcd.com)

**REVISION HISTORY**

Version	Date	Page (New)	Section	Description
Ver 0.0	Sep.2,'02	All	All	Tentative Specification was first issued.

www.jxlcd.com

## 1. GENERAL DESCRIPTION

### 1.1 OVERVIEW

N150X2 - L01 is a 15.0" TFT Liquid Crystal Display module with single CCFL Backlight unit and 30 pins LVDS interface. This module supports 1024 x 768 XGA mode and can display 262,144 colors. The optimum viewing angle is at 6 o'clock direction. The inverter module for Backlight is not built in.

### 1.2 FEATURES

- Thin and light weight
- XGA (1024 x 768 pixels) resolution
- Standard mode
- 3.3V LVDS (Low Voltage Differential Signaling) interface with 1 pixel/clock

### 1.3 APPLICATION

- TFT LCD Notebook

### 1.4 GENERAL SPECIFICATIONS

Item	Specification	Unit	Note
Active Area	304.1 (H) x 228.1 (V) (15.0" diagonal)	mm	(1)
Bezel Opening Area	307.6 (H) x 231.6 (V)	mm	
Driver Element	a-si TFT active matrix	-	-
Pixel Number	1024 x R.G.B. x 768	pixel	-
Pixel Pitch	0.297 (H) x 0.297 (V)	mm	-
Pixel Arrangement	RGB vertical stripe	-	-
Display Colors	262,144	color	-
Transmissive Mode	Normally white	-	-
Surface Treatment	Hard coating (3H), Anti-glare (Haze 12)	-	-

### 1.5 MECHANICAL SPECIFICATIONS

Item		Min.	Typ.	Max.	Unit	Note
Module Size	Horizontal(H)	315.5	315.8	316.1	mm	(1)
	Vertical(V)	240.2	240.5	240.8	mm	
	Depth(D)	-	5.7	6.0	mm	
Weight		-	(510)	(525)	g	-

Note (1) Please refer to the attached drawings for more information of front and back outline dimensions.

## 2. ABSOLUTE MAXIMUM RATINGS

### 2.1 ABSOLUTE RATINGS OF ENVIRONMENT

Item	Symbol	Value		Unit	Note
		Min.	Max.		
Storage Temperature	T <sub>ST</sub>	-20	+60	°C	(1)
Operating Ambient Temperature	T <sub>OP</sub>	0	+50	°C	(1), (2)
Shock (Non-Operating)	S <sub>NOP</sub>	-	(200)	G	(3), (5)
Vibration (Non-Operating)	V <sub>NOP</sub>	-	(1.5)	G	(4), (5)

Note (1) Temperature and relative humidity range is shown in the figure below.

- (a) 90 %RH Max. ( $T_a \leq 40\text{ }^\circ\text{C}$ ).
- (b) Wet-bulb temperature should be 39 °C Max. ( $T_a > 40\text{ }^\circ\text{C}$ ).
- (c) No condensation of water.

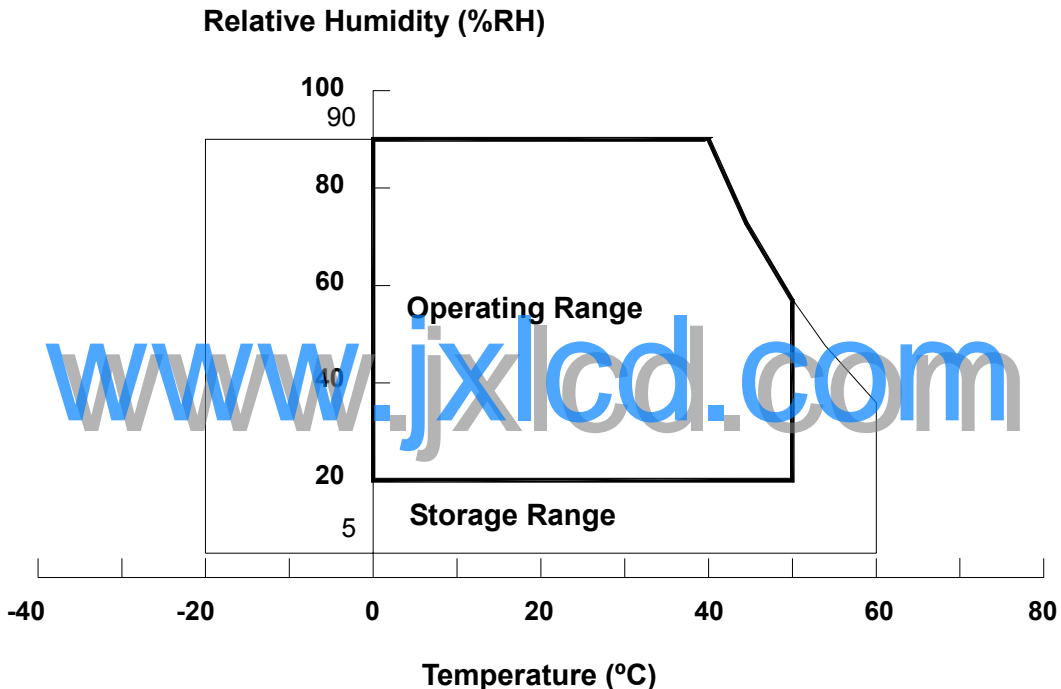

Note (2) The temperature of panel surface should be 0 °C Min. and 60 °C Max.

Note (3) 2ms, half sine wave, 1 time for ± X, ± Y, ± Z.

Note (4) 10 ~ 500 Hz, 0.5 Hr each X, Y, Z.

Note (5) At testing Vibration and Shock, the fixture in holding the module has to be hard and rigid enough so that the module would not be twisted or bent by the fixture.

## 2.2 ELECTRICAL ABSOLUTE RATINGS

### 2.2.1 TFT LCD MODULE

Item	Symbol	Value		Unit	Note
		Min.	Max.		
Power Supply Voltage	V <sub>CC</sub>	-0.3	+4.0	V	(1)
Logic Input Voltage	V <sub>IN</sub>	-0.3	V <sub>CC</sub> +0.3	V	

### 2.2.2 BACKLIGHT UNIT

Item	Symbol	Value		Unit	Note
		Min.	Max.		
Lamp Voltage	V <sub>L</sub>	-	2.5K	V <sub>RMS</sub>	(1), (2), I <sub>L</sub> = (6.0) mA
Lamp Current	I <sub>L</sub>	-	6.5	mA <sub>RMS</sub>	
Lamp Frequency	F <sub>L</sub>	-	80	KHZ	

Note (1) Permanent damage to the device may occur if maximum values are exceeded. Function operation should be restricted to the conditions described under Normal Operating Conditions.

Note (2) Specified values are for lamp (Refer to Section 3.2 for further information).

## 3. ELECTRICAL CHARACTERISTICS

### 3.1 TFT LCD MODULE

Parameter	Symbol	Value			Unit	Note	
		Min.	Typ.	Max.			
Power Supply Voltage	V <sub>CC</sub>	3.0	3.3	3.6	V	-	
Ripple Voltage	V <sub>RP</sub>	-	(50)	-	mV	-	
Rush Current	I <sub>RUSH</sub>	-	-	(1.5)	A	(2)	
Power Supply Current	White	-	TBD	-	mA	(3)a	
	Black	-	TBD	-	mA	(3)b	
	Vertical Stripe	-	TBD	-	mA	(3)c	
Logical Input Voltage	"H" Level	V <sub>IL</sub>	-	-	+100	mV	-
	"L" Level	V <sub>IH</sub>	-100	-	-	mV	-
Terminating Resistor	R <sub>T</sub>	-	100	-	Ohm	-	

Note (1) The module should be always operated within above ranges.

Note (2) Measurement Conditions:

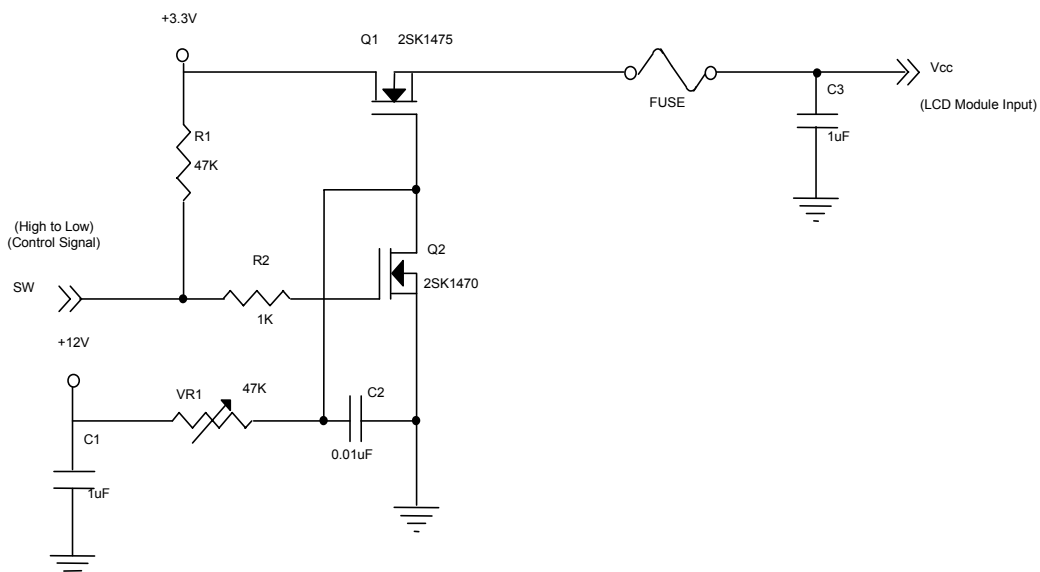

**Vcc rising time is 470us**

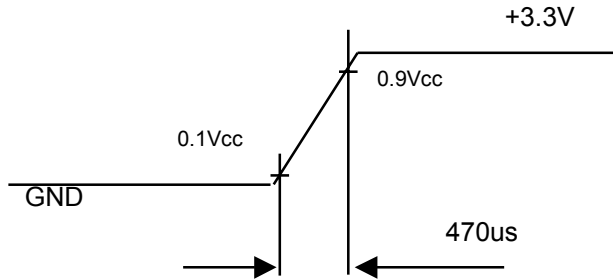

Note (3) The specified power supply current is under the conditions at  $V_{cc} = 3.3\text{ V}$ ,  $T_a = 25 \pm 2\text{ }^\circ\text{C}$ ,  $f_v = 60\text{ Hz}$ , whereas a power dissipation check pattern below is displayed.

a. White Pattern



Active Area

b. Black Pattern



Active Area

c. Vertical Stripe Pattern

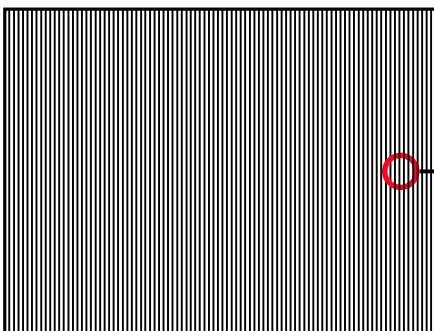

Active Area

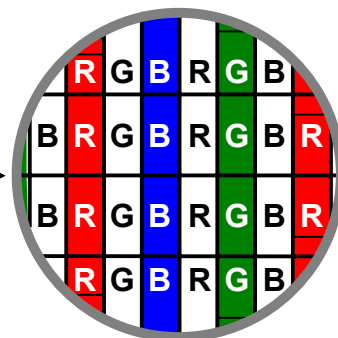

### 3.2 BACKLIGHT UNIT

Ta = 25 ± 2 °C

Parameter	Symbol	Value			Unit	Note
		Min.	Typ.	Max.		
Lamp Input Voltage	V <sub>L</sub>		(675)		V <sub>RMS</sub>	I <sub>L</sub> = (6.0) mA
Lamp Current	I <sub>L</sub>	(2.0)	(6.0)	(6.5)	mA <sub>RMS</sub>	(1)
Lamp Turn On Voltage	V <sub>s</sub>	-		(1100) (25 °C)	V <sub>RMS</sub>	(2)
		-		(1300) (0 °C)	V <sub>RMS</sub>	(2)
Operating Frequency	F <sub>L</sub>	(40)	(50)	(67)	KHz	(3)
Lamp Life Time	L <sub>BL</sub>	10,000	15,000	-	Hrs	(5)
Power Consumption	P <sub>L</sub>	-	(4.4)	-	W	(4), I <sub>L</sub> = (6.0) mA

Note (1) Lamp current is measured by utilizing a high frequency current meter as shown below:

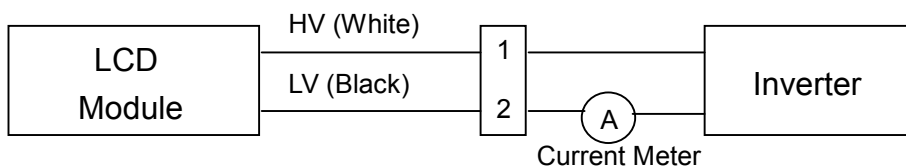

Note (2) The voltage shown above should be applied to the lamp for more than 1 second after startup. Otherwise the lamp may not be turned on.

Note (3) The lamp frequency may produce interference with horizontal synchronous frequency from the display, and this may cause line flow on the display. In order to avoid interference, the lamp frequency should be detached from the horizontal synchronous frequency and its harmonics as far as possible.

Note (4)  $P_L = I_L \times V_L$

Note (5) The lifetime of lamp can be defined as the time in which it continues to operate under the condition Ta = 25 ± 2 °C and I<sub>L</sub> = (6.0) mA<sub>RMS</sub> until one of the following events occurs:

- (a) When the brightness becomes or lower than 50% of its original value.
- (b) When the effective ignition length becomes or lower than 80% of its original value. (Effective ignition length is defined as an area that has less than 70% brightness compared to the brightness in the center point.)

Note (6) The waveform of the voltage output of inverter must be area-symmetric and the design of the inverter must have specifications for the modularized lamp. The performance of the Backlight, such as lifetime or brightness, is greatly influenced by the characteristics of the DC-AC inverter for the lamp. All the parameters of an inverter should be carefully designed to avoid producing too much current leakage from high voltage output of the inverter. When designing or ordering the inverter please make sure that a poor lighting caused by the mismatch of the Backlight and the inverter (miss-lighting, flicker, etc.) never occurs. If the above situation is confirmed, the module should be operated in the same manners when it is installed in your instrument.



## 4. BLOCK DIAGRAM

### 4.1 TFT LCD MODULE

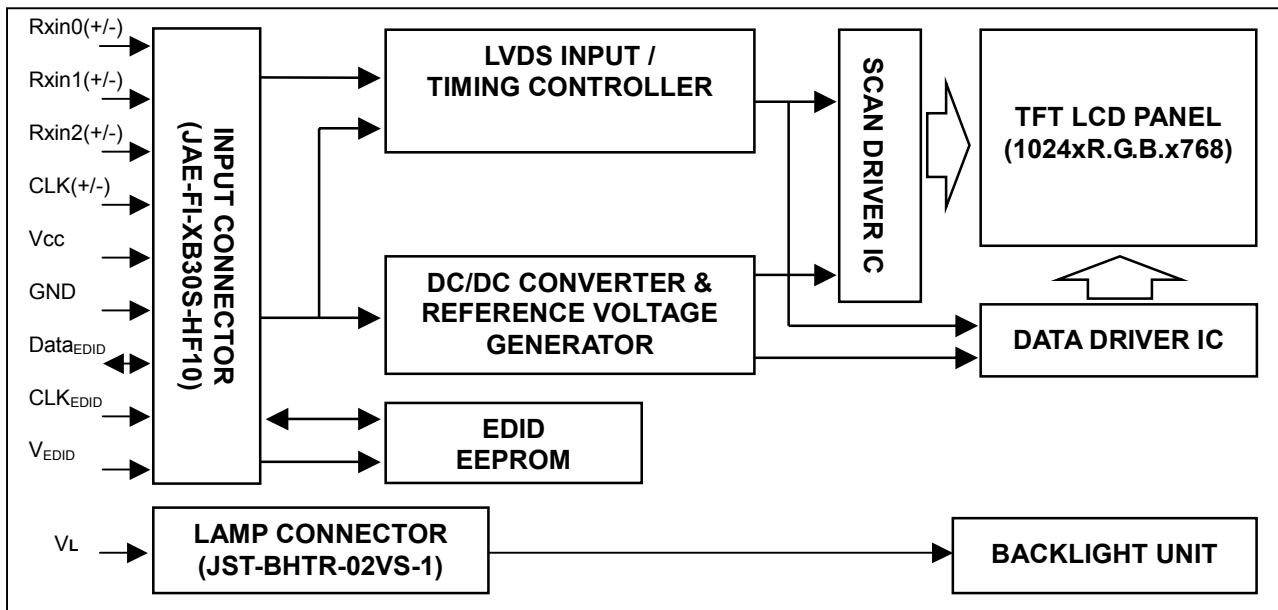

### 4.2 BACKLIGHT UNIT

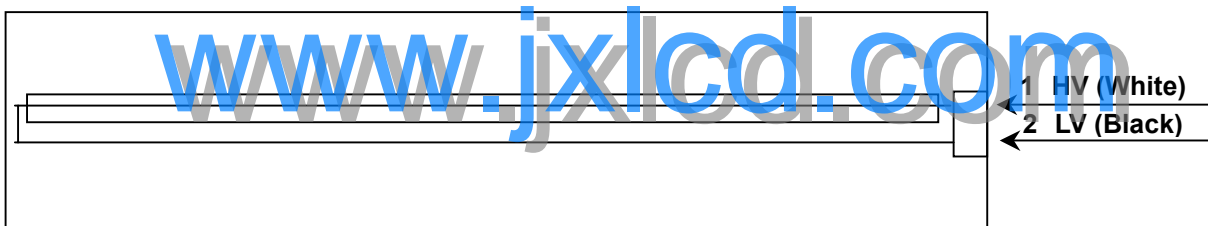

## 5. INPUT TERMINAL PIN ASSIGNMENT

### 5.1 TFT LCD MODULE

Pin	Symbol	Description	Polarity	Remark
1	V <sub>ss</sub>	Ground		
2	V <sub>cc</sub>	Power Supply +3.3 V (typical)		
3	V <sub>cc</sub>	Power Supply +3.3 V (typical)		
4	V <sub>EDID</sub>	DDC 3.3V Power		
5	NC	Non-Connection		
6	CLK <sub>EDID</sub>	DDC Clock		
7	DATA <sub>EDID</sub>	DDC Data		
8	Rxin0-	LVDS Differential Data Input	Negative	R0~R5, G0
9	Rxin0+	LVDS Differential Data Input	Positive	-
10	V <sub>ss</sub>	Ground		
11	Rxin1-	LVDS Differential Data Input	Negative	G1~G5, B0, B1
12	Rxin1+	LVDS Differential Data Input	Positive	-
13	V <sub>ss</sub>	Ground		

14	Rxin2-	LVDS Differential Data Input	Negative	B2~B5,DE,Hsync,Vsync
15	Rxin2+	LVDS Differential Data Input	Positive	
16	Vss	Ground		
17	CLK-	LVDS Clock Data Input	Negative	LVDS Level
18	CLK+	LVDS Clock Data Input	Positive	
19	Vss	Ground		
20	NC	Non-Connection		
21	NC	Non-Connection		
22	Vss	Ground		
23	NC	Non-Connection		
24	NC	Non-Connection		
25	Vss	Ground		
26	NC	Non-Connection		
27	NC	Non-Connection		
28	Vss	Ground		
29	NC	Non-Connection		
30	NC	Non-Connection		

Note (1) Connector Part No.: JAE-FI-XB30S-HF10 or equivalent

Note (2) User's connector Part No: JAE-FI-X30M or equivalent

Note (3) The first pixel is even.

### 5.2 BACKLIGHT UNIT

Pin	Symbol	Description	Color
1	HV	High Voltage	White
2	LV	Ground	Black

Note (1) Connector PN: JST-FI-XB30S-HF10 or equivalent

Note (2) User's connector Part No.: SM02B-BHSS-1-TB or equivalent

### 5.3 TIMING DIAGRAM OF LVDS INPUT SIGNAL

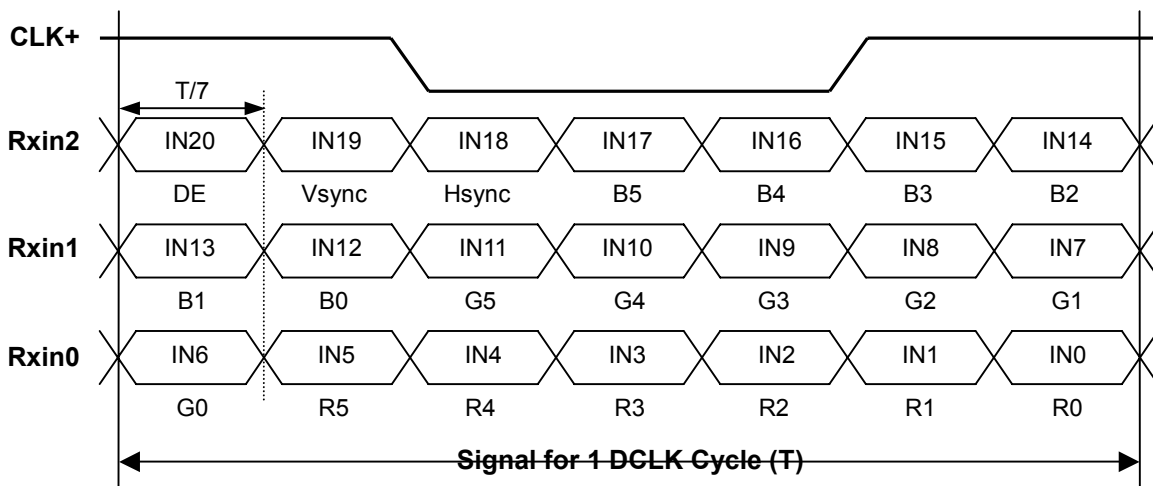

## 5.4 COLOR DATA INPUT ASSIGNMENT

The brightness of each primary color (red, green and blue) is based on the 6-bit gray scale data input for the color. The higher the binary input, the brighter the color. The table below provides the assignment of color versus data input.

Color		Data Signal																	
		Red						Green						Blue					
		R5	R4	R3	R2	R1	R0	G5	G4	G3	G2	G1	G0	B5	B4	B3	B2	B1	B0
Basic Colors	Black	0	0	0	0	0	0	0	0	0	0	0	0	0	0	0	0	0	0
	Red	1	1	1	1	1	1	0	0	0	0	0	0	0	0	0	0	0	0
	Green	0	0	0	0	0	0	1	1	1	1	1	1	0	0	0	0	0	0
	Blue	0	0	0	0	0	0	0	0	0	0	0	0	1	1	1	1	1	1
	Cyan	0	0	0	0	0	0	1	1	1	1	1	1	1	1	1	1	1	1
	Magenta	1	1	1	1	1	1	0	0	0	0	0	0	0	1	1	1	1	1
	Yellow	1	1	1	1	1	1	1	1	1	1	1	1	0	0	0	0	0	0
	White	1	1	1	1	1	1	1	1	1	1	1	1	1	1	1	1	1	1
Gray Scale Of Red	Red(0)/Dark	0	0	0	0	0	0	0	0	0	0	0	0	0	0	0	0	0	0
	Red(1)	0	0	0	0	0	1	0	0	0	0	0	0	0	0	0	0	0	0
	Red(2)	0	0	0	0	1	0	0	0	0	0	0	0	0	0	0	0	0	0
	⋮	⋮	⋮	⋮	⋮	⋮	⋮	⋮	⋮	⋮	⋮	⋮	⋮	⋮	⋮	⋮	⋮	⋮	⋮
	⋮	⋮	⋮	⋮	⋮	⋮	⋮	⋮	⋮	⋮	⋮	⋮	⋮	⋮	⋮	⋮	⋮	⋮	⋮
	⋮	⋮	⋮	⋮	⋮	⋮	⋮	⋮	⋮	⋮	⋮	⋮	⋮	⋮	⋮	⋮	⋮	⋮	⋮
	Red(61)	1	1	1	1	0	1	0	0	0	0	0	0	0	0	0	0	0	0
	Red(62)	1	1	1	1	1	0	0	0	0	0	0	0	0	0	0	0	0	0
Red(63)	1	1	1	1	1	1	0	0	0	0	0	0	0	0	0	0	0	0	
Gray Scale Of Green	Green(0)/Dark	0	0	0	0	0	0	0	0	0	0	0	0	0	0	0	0	0	0
	Green(1)	0	0	0	0	0	0	0	0	0	0	0	1	0	0	0	0	0	0
	Green(2)	0	0	0	0	0	0	0	0	0	0	1	0	0	0	0	0	0	0
	⋮	⋮	⋮	⋮	⋮	⋮	⋮	⋮	⋮	⋮	⋮	⋮	⋮	⋮	⋮	⋮	⋮	⋮	⋮
	⋮	⋮	⋮	⋮	⋮	⋮	⋮	⋮	⋮	⋮	⋮	⋮	⋮	⋮	⋮	⋮	⋮	⋮	⋮
	⋮	⋮	⋮	⋮	⋮	⋮	⋮	⋮	⋮	⋮	⋮	⋮	⋮	⋮	⋮	⋮	⋮	⋮	⋮
	Green(61)	0	0	0	0	0	1	1	1	1	0	1	0	0	0	0	0	0	0
	Green(62)	0	0	0	0	0	1	1	1	1	1	0	0	0	0	0	0	0	0
Green(63)	0	0	0	0	0	1	1	1	1	1	1	0	0	0	0	0	0	0	
Gray Scale Of Blue	Blue(0)/Dark	0	0	0	0	0	0	0	0	0	0	0	0	0	0	0	0	0	0
	Blue(1)	0	0	0	0	0	0	0	0	0	0	0	0	0	0	0	0	0	1
	Blue(2)	0	0	0	0	0	0	0	0	0	0	0	0	0	0	0	0	1	0
	⋮	⋮	⋮	⋮	⋮	⋮	⋮	⋮	⋮	⋮	⋮	⋮	⋮	⋮	⋮	⋮	⋮	⋮	⋮
	⋮	⋮	⋮	⋮	⋮	⋮	⋮	⋮	⋮	⋮	⋮	⋮	⋮	⋮	⋮	⋮	⋮	⋮	⋮
	⋮	⋮	⋮	⋮	⋮	⋮	⋮	⋮	⋮	⋮	⋮	⋮	⋮	⋮	⋮	⋮	⋮	⋮	⋮
	Blue(61)	0	0	0	0	0	0	0	0	0	0	0	1	1	1	1	0	1	0
	Blue(62)	0	0	0	0	0	0	0	0	0	0	0	1	1	1	1	1	0	0
Blue(63)	0	0	0	0	0	0	0	0	0	0	0	1	1	1	1	1	1	1	

Note (1) 0: Low Level Voltage, 1: High Level Voltage

## 6. INTERFACE TIMING

### 6.1 INPUT SIGNAL TIMING SPECIFICATIONS

The input signal timing specifications are shown as the following table and timing diagram.

Signal	Item	Symbol	Min.	Typ.	Max.	Unit	Note
DCLK	Frequency	1/Tc	(20)	65	(68)	MHz	-
DE	Frame Time Cycle	TV	(771)	806	(850)	TH	-
	Vertical Active Display Period	TVD	768	768	768	TH	-
	One Line Scanning Time Cycle	TH	(1200)	1344	(1600)	Tc	-
	Horizontal Active Display Period	THD	1024	1024	1024	Tc	-

Note (1) Because this module is operated by DE only mode, Hsync and Vsync input signals should be set to low logic level or ground. Otherwise, this module would operate abnormally.

**INPUT SIGNAL TIMING DIAGRAM**

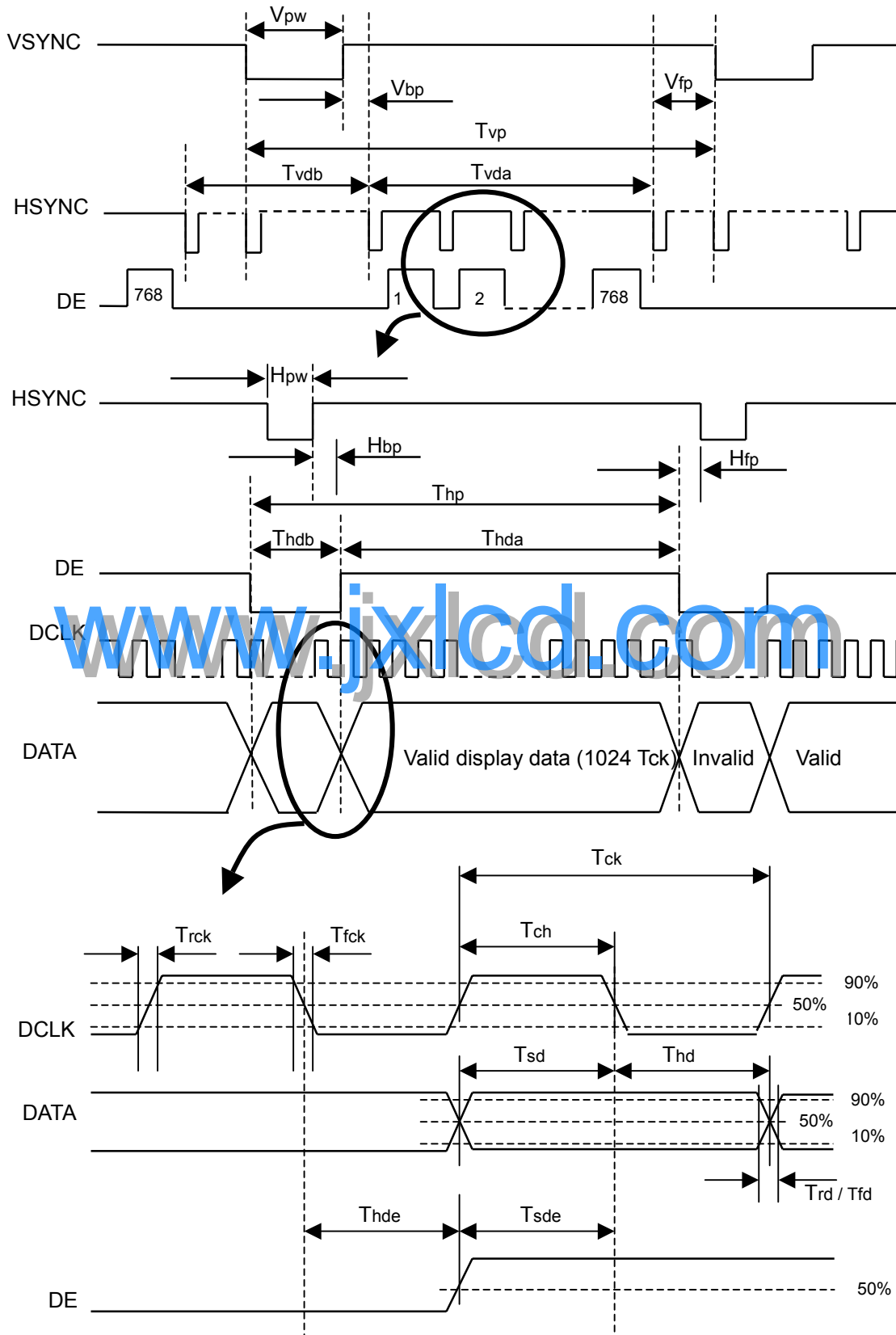

## 6.2 POWER ON/OFF SEQUENCE

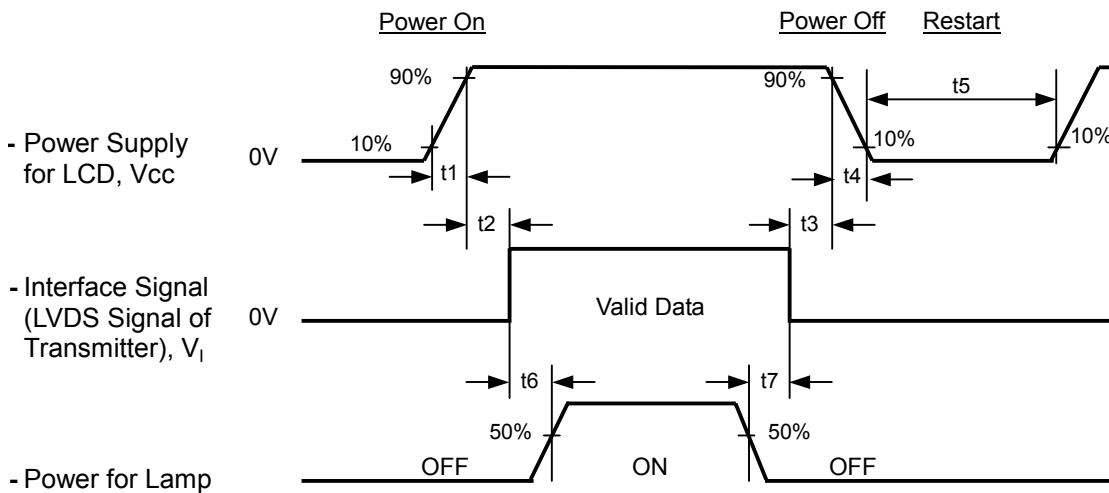

### Timing Specifications:

- $0 < t_1 \leq (10) \text{ msec}$
- $0 < t_2 \leq (50) \text{ msec}$
- $0 < t_3 \leq (50) \text{ msec}$
- $0 \leq t_4 \leq 50 \text{ msec (given by system)}$
- $0 \leq t_4 \leq 400 \text{ nsec (measured on TFT-LCD module)}$
- $t_5 \leq (500) \text{ msec}$
- $t_6 \leq (200) \text{ msec}$
- $t_7 \leq (200) \text{ msec}$

Note (1) Please avoid floating state of interface signal at invalid period.

Note (2) When the interface signal is invalid, be sure to pull down the power supply of LCD V<sub>CC</sub> to 0 V.

Note (3) The Backlight inverter power must be turned on after the power supply for the logic and the interface signal is valid. The Backlight inverter power must be turned off before the power supply for the logic and the interface signal is invalid.

## 7. OPTICAL CHARACTERISTICS

### 7.1 TEST CONDITIONS

Item	Symbol	Value	Unit
Ambient Temperature	Ta	25±2	°C
Ambient Humidity	Ha	50±10	%RH
Supply Voltage	V <sub>CC</sub>	3.3	V
Input Signal	According to typical value in "3. ELECTRICAL CHARACTERISTICS"		
Inverter Current	I <sub>L</sub>	(6.0)	mA
Inverter Driving Frequency	F <sub>L</sub>	(50)	KHz
Inverter		TBD	

The relative measurement methods of optical characteristics are shown in 6.2. The following items should be measured under the test conditions described in 6.1 and stable environment shown in Note (6).

### 7.2 OPTICAL SPECIFICATIONS

Item	Symbol	Condition	Min.	Typ.	Max.	Unit	Note	
Contrast Ratio (5 points)	CR <sub>AVE</sub>	$\theta_x=0^\circ, \theta_y=0^\circ$ Viewing Normal Angle	(200)	(250)-	-	-	(2), (6)	
Response Time	T <sub>R</sub>		-	(15)			ms	(3)
	T <sub>F</sub>		-	(35)			ms	
Average Luminance of White (5 points)	L <sub>AVE</sub>				170	-	cd/m <sup>2</sup>	(4), (6)
Cross Talk	CT			-	-	3	%	(5), (6)
Color Chromaticity	Red		Rx		TBD		-	(1), (6)
			Ry		TBD		-	
	Green		Gx		TBD		-	
			Gy		TBD		-	
	Blue		Bx		TBD		-	
		By		TBD		-		
White	Wx		(0.280)	(0.310)	(0.340)	-		
	Wy		(0.300)	(0.330)	(0.360)	-		
Viewing Angle	Horizontal	$\theta_{x+}$	(40)	(45)		Deg.		
		$\theta_{x-}$	(40)	(45)				
	Vertical	$\theta_{y+}$	(15)	(20)				
		$\theta_{y-}$	(35)	(40)				

Note (1) Definition of Viewing Angle ( $\theta_x, \theta_y$ ):

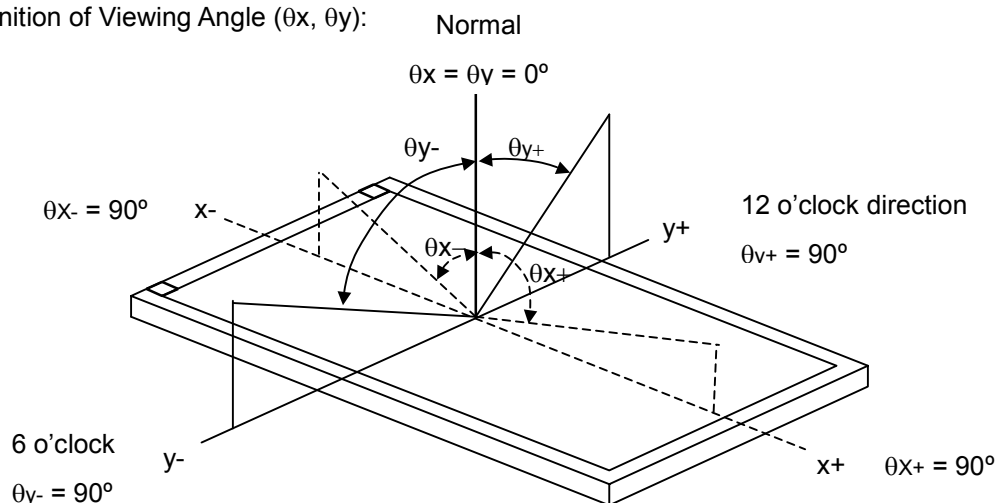

Note (2) Definition of Contrast Ratio (CR):

The contrast ratio can be calculated by the following expression.

$$\text{Contrast Ratio (CR)} = L_{63} / L_0$$

L63: Luminance of gray level 63

L 0: Luminance of gray level 0

$$\text{CR} = \text{CR (7)}$$

CR (X) is corresponding to the Contrast Ratio of the point X at Figure in Note (7).

Note (3) Definition of Response Time ( $T_R$ ,  $T_F$ ):

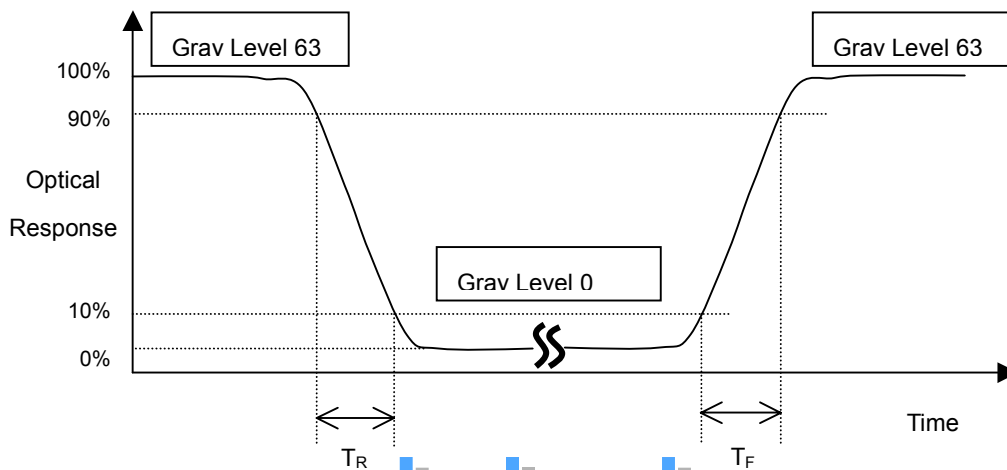

Note (4) Definition of Average Luminance of White ( $L_{AVE}$ ):

Measure the luminance of gray level 63 at 5 points

$$L_{AVE} = [L(4) + L(5) + L(7) + L(9) + L(10)] / 5$$

L (x) is corresponding to the luminance of the point X at Figure in Note (7).

Note (5) Definition of Cross Talk (CT):

$$CT = |Y_B - Y_A| / Y_A \times 100 (\%)$$

Where:

$Y_A$  = Luminance of measured location without gray level 0 pattern ( $cd/m^2$ )

$Y_B$  = Luminance of measured location with gray level 0 pattern ( $cd/m^2$ )

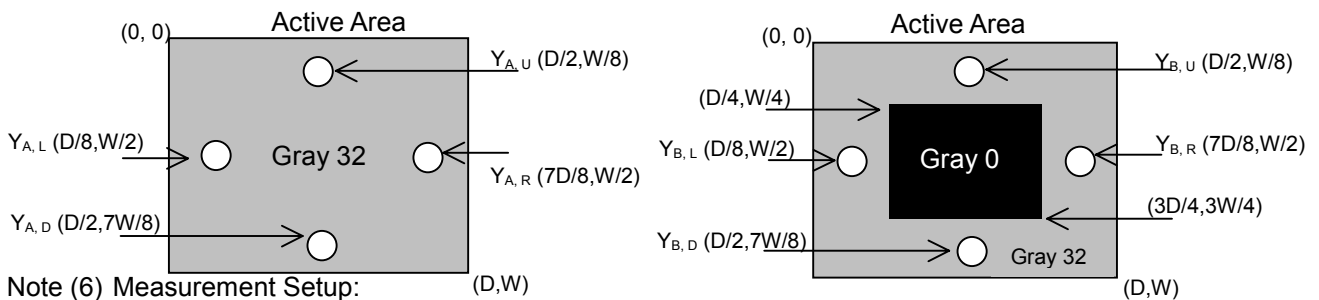

Note (6) Measurement Setup:

The LCD module should be stabilized at given temperature for 20 minutes to avoid abrupt

temperature change during measuring. In order to stabilize the luminance, the measurement should be executed after lighting Backlight for 20 minutes in a windless room.

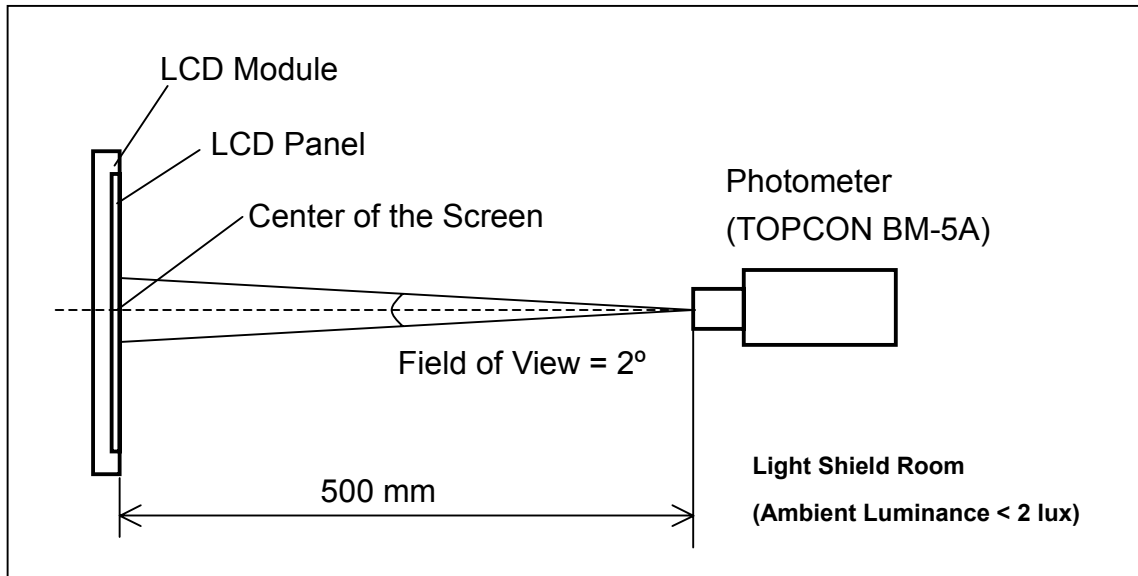

Note (7) Definition of White Variation ( $\delta W$ ):

Measure the luminance of gray level 63 at 5 points

$$\delta W = \text{Maximum} [L(1), L(2), L(3), L(4), L(5)] / \text{Minimum} [L(1), L(2), L(3), L(4), L(5)]$$

[www.jxlcd.com](http://www.jxlcd.com)

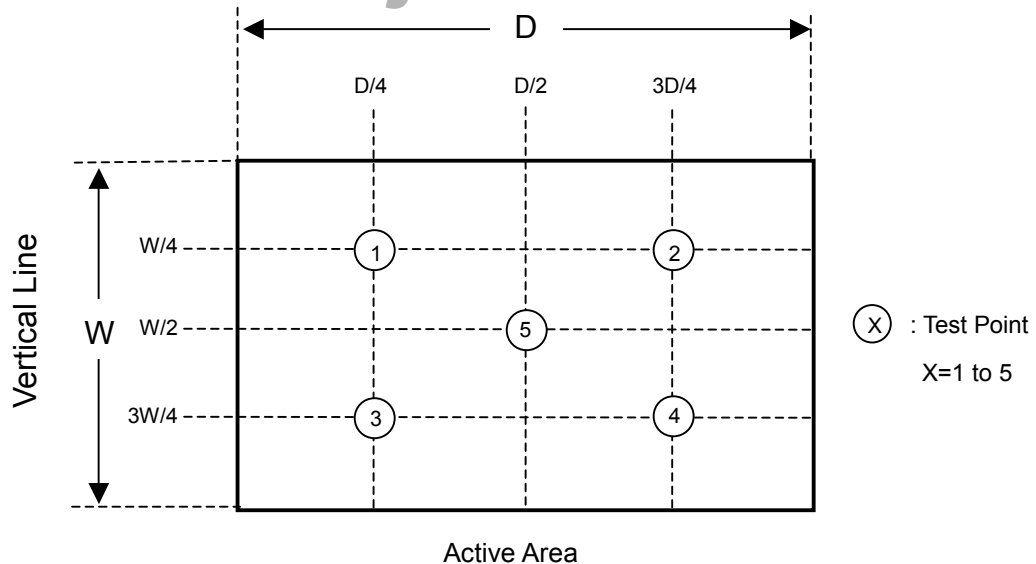



## 8. PRECAUTIONS

### 8.1 ASSEMBLY AND HANDLING PRECAUTIONS

- (1) Do not apply rough force such as bending or twisting to the module during assembly.
- (2) To assemble or install module into user's system can be only in clean working areas. The dust and oil may cause electrical short or worsen the polarizer.
- (3) It's not permitted to have pressure or impulse on the module because the LCD panel and Backlight will be damaged.
- (4) Always follow the correct power sequence when LCD module is connecting and operating. This can prevent damage to the CMOS LSI chips during latch-up.
- (5) Do not pull the I/F connector in or out while the module is operating.
- (6) Do not disassemble the module.
- (7) Use a soft dry cloth without chemicals for cleaning, because the surface of polarizer is very soft and easily scratched.
- (8) It is dangerous that moisture come into or contacted the LCD module, because moisture may damage LCD module when it is operating.
- (9) High temperature or humidity may reduce the performance of module. Please store LCD module within the specified storage conditions.
- (10) When ambient temperature is lower than 10°C may reduce the display quality. For example, the response time will become slowly, and the starting voltage of CCFL will be higher than room temperature.

[www.jxlcd.com](http://www.jxlcd.com)

### 8.2 SAFETY PRECAUTIONS

- (1) The startup voltage of Backlight is approximately 1000 Volts. It may cause electrical shock while assembling with inverter. Do not disassemble the module or insert anything into the Backlight unit.
- (2) If the liquid crystal material leaks from the panel, it should be kept away from the eyes or mouth. In case of contact with hands, skin or clothes, it has to be washed away thoroughly with soap.
- (3) After the module's end of life, it is not harmful in case of normal operation and storage.

## 9. DEFINITION OF LABELS

### 9.1 CMO MODULE LABEL

The barcode nameplate is pasted on each module as illustration, and its definitions are as following explanation.



- (a) Model Name: N150X2-L01
- (b) Revision: Rev. XX:   Sample       : A1, A2, A3,..., etc.  
                                  CS & MP     : C1, C2, C3,...etc.

Note: It will happen that revision code changed without product changed in developing duration because of CMO internal stage change, for example: AX → B1, BX → C1.

- (c) Serial ID: XXXXXXYMDLNNNN

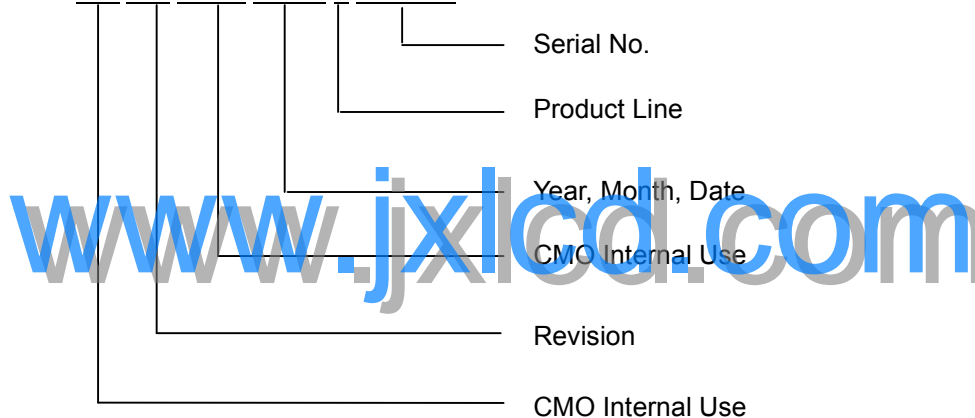

Serial ID includes the information as below:

- (a) Manufactured Date: Year: 0 ~ 9, for 2000 ~ 2009.  
                                  Month: 1 ~ 9, A ~ C, for Jan. ~ Dec.  
                                  Day: 1 ~ 9, A ~ Y, for 1<sup>st</sup> to 31<sup>st</sup>, exclude I, O and U.
- (b) Revision Code: cover all the changes.
- (c) Serial No.: Manufacturing sequence of product Line: 1 -> Line1, 2 -> Line 2, ...etc.

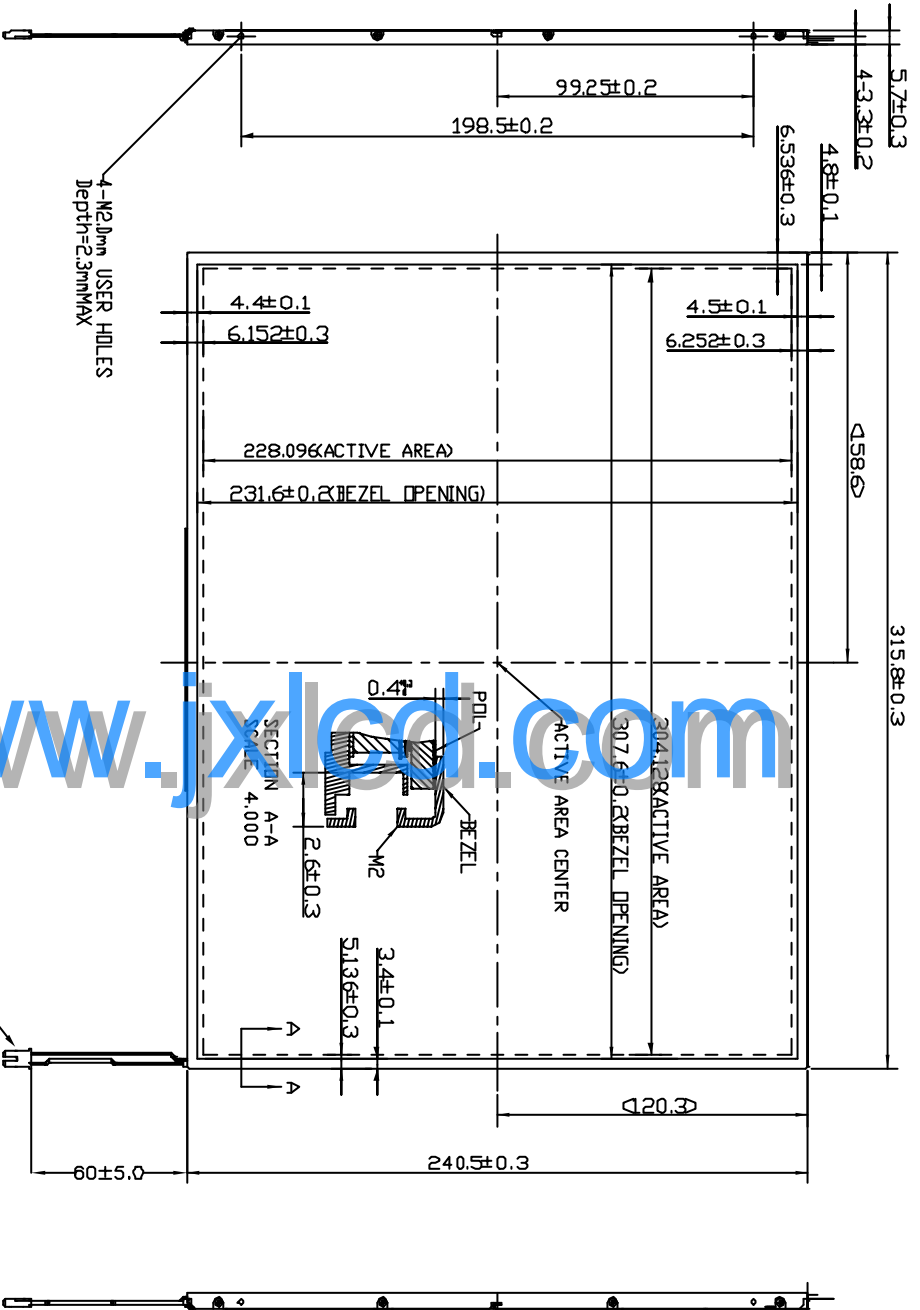

NOTES:  
1.SCREW TORQUE FOR MOUNTING SHALL NOT EXCEED 30mgt-cm.

www.ixltd.com

CHI MEI  
This drawing is preliminary data and can be changed without previous notice.

CHI MEI  
OPTOELECTRONICS CORP.  
奇美電子股份有限公司

APPROVED: DWG NO.: N150341011  
CHECKED: DATE: 08/30/2002

DESIGNER: PART NO.:  
DRAWER: REV.: 2 UNIT: SCALE: SHEET:

TITLE: OUTLINE N150X2 MM 1/2 1/2

CHI MEI COPYRIGHT 2002, ALL RIGHTS RESERVED, COPYING FORBIDDEN.

MARK	DESCRIPTION	DATE	CHANGE BY	APPROVAL BY	ECN NO.

MARK	DESCRIPTION	DATE	CHANGE BY	APPROVAL BY	ECN NO.

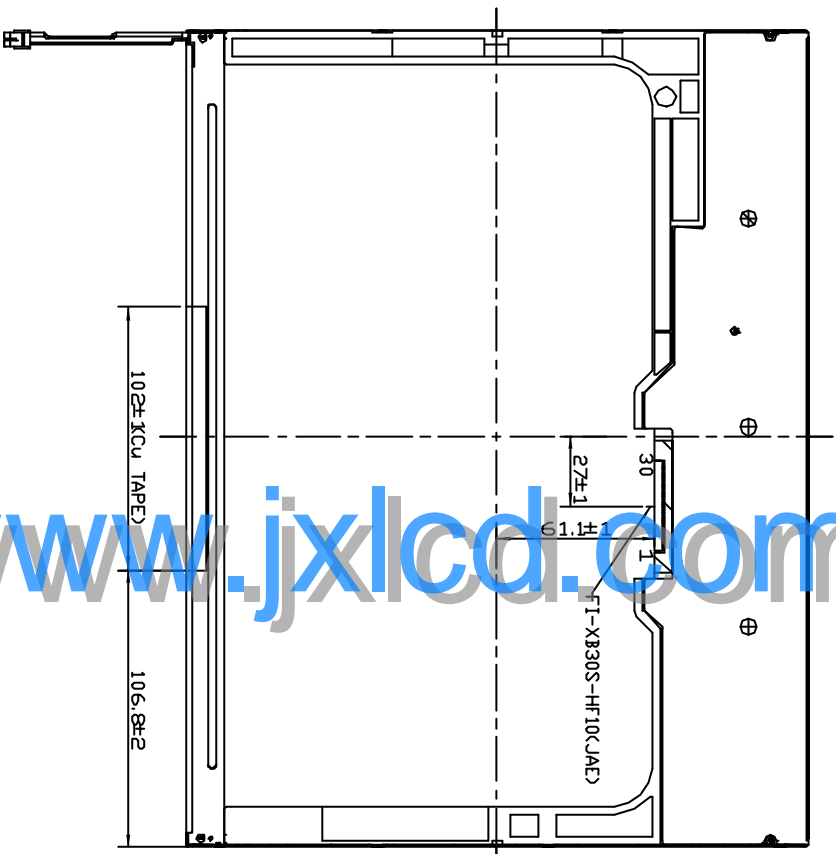

www.jxlcd.com

CHI MEI  
This drawing is  
and can be used

**CHI MEI**  
 奇美電子股份有限公司  
 QIMEI ELECTRONICS CORP.  
 APPROVED: \_\_\_\_\_  
 CHECKED: \_\_\_\_\_  
 DESIGNER: \_\_\_\_\_  
 DRAWER: \_\_\_\_\_  
 TITLE: OUTLINE N150X2

APPROVED:	DWG NO	N150341011
CHECKED:	DATE:	
DESIGNER:	PART NO.:	
DRAWER:	REV.:	2

TITLE:	UNIT:	SCALE:	SHEET:
OUTLINE N150X2	MM	1/2	2/2

©CHI MEI COPYRIGHT 2002, ALL RIGHTS RESERVED, COPYING FORBIDDEN.

MARK	DESCRIPTION	DATE	CHANGE BY	APPROVAL BY	ECN NO.
8					
7					
6					
5					
4					
3					
2					
1					