



TFT LCD Approval Specification



MODEL NO.: N150X3 - L08

Rev.C2

Customer: _____

Approved by: _____

Note:

Liquid Crystal Display Division	
QRA Division.	OA Head Division.
Approval	Approval
	

- CONTENTS -

REVISION HISTORY

1. GENERAL DESCRIPTION
 - 1.1 OVERVIEW
 - 1.2 FEATURES
 - 1.3 APPLICATION
 - 1.4 GENERAL SPECIFICATIONS
 - 1.5 MECHANICAL SPECIFICATIONS
2. ABSOLUTE MAXIMUM RATINGS
 - 2.1 ABSOLUTE RATINGS OF ENVIRONMENT
 - 2.2 ELECTRICAL ABSOLUTE RATINGS
 - 2.2.1 TFT LCD MODULE
 - 2.2.2 BACKLIGHT UNIT
3. ELECTRICAL CHARACTERISTICS
 - 3.1 TFT LCD MODULE
 - 3.2 BACKLIGHT UNIT
4. BLOCK DIAGRAM
 - 4.1 TFT LCD MODULE
 - 4.2 BACKLIGHT UNIT
5. INPUT TERMINAL PIN ASSIGNMENT
 - 5.1 TFT LCD MODULE
 - 5.2 BACKLIGHT UNIT
 - 5.3 TIMING DIAGRAM OF LVDS INPUT SIGNAL
 - 5.4 COLOR DATA INPUT ASSIGNMENT
6. INTERFACE TIMING
 - 6.1 INPUT SIGNAL TIMING SPECIFICATIONS
 - 6.2 POWER ON/OFF SEQUENCE
7. OPTICAL CHARACTERISTICS
 - 7.1 TEST CONDITIONS
 - 7.2 OPTICAL SPECIFICATIONS
8. PRECAUTIONS
 - 8.1 ASSEMBLY AND HANDLING PRECAUTIONS
 - 8.2 SAFETY PRECAUTIONS
9. DEFINITION OF LABELS
 - 9.1 CMO MODULE LABEL
 - 9.2 CMO CARTON LABEL
10. PACKAGING
 - 10.1 Packing Specification
 - 10.2 Packing Method

REVISION HISTORY

Version	Date	Page (New)	Section	Description
1.0	Nov.18.'04	All	All	Preliminary specification was first issue.
2.0	Sep.27 '05	All	All	Approval specification was first issued
2.1	Nov. 15,'05	All	All	Approval spec rev C2

1. GENERAL DESCRIPTION

1.1 OVERVIEW

N150X3 - L08 is a 15.0" TFT Liquid Crystal Display ROHS module with single CCFL Backlight unit and 30 pins LVDS interface. This module supports 1024 x 768 XGA mode and can display 262,144 colors. The optimum viewing angle is at 6 o'clock direction. The inverter module for Backlight is not built in.

1.2 FEATURES

- Thin and Light Weight
- XGA (1024 x 768 pixels) resolution
- DE only mode
- 3.3V LVDS (Low Voltage Differential Signaling) interface with 1 pixel/clock

1.3 APPLICATION

- TFT LCD Notebook

1.4 GENERAL SPECIFICATIONS

Item	Specification	Unit	Note
Active Area	304.1 (H) x 228.1 (V) (15.0" diagonal)	mm	(1)
Bezel Opening Area	307.8 (H) x 231.6 (V)	mm	
Driver Element	a-si TFT active matrix	-	-
Pixel Number	1024 x R.G.B. x 768	pixel	-
Pixel Pitch	0.297 (H) x 0.297 (V)	mm	-
Pixel Arrangement	RGB vertical stripe	-	-
Display Colors	262,144	color	-
Transmissive Mode	Normally white	-	-
Surface Treatment	Hard coating (2H), Glare type	-	-

1.5 MECHANICAL SPECIFICATIONS

Item		Min.	Typ.	Max.	Unit	Note
Module Size	Horizontal(H)	316.8	317.3	317.8	mm	(1)
	Vertical(V)	241.5	242	242.5	mm	
	Depth(D)	5.4	5.7	6.0	mm	
Weight		535	550	565	g	-

Note (1) Please refer to the attached drawings for more information of front and back outline dimensions.

2. ABSOLUTE MAXIMUM RATINGS

2.1 ABSOLUTE RATINGS OF ENVIRONMENT

Item	Symbol	Value		Unit	Note
		Min.	Max.		
Storage Temperature	T _{ST}	-20	+60	°C	(1)
Operating Ambient Temperature	T _{OP}	0	+50	°C	(1), (2)
Shock (Non-Operating)	S _{NOP}	-	200/2	G/ms	(3), (5)
Vibration (Non-Operating)	V _{NOP}	-	1.5	G	(4), (5)

Note (1) (a) 90 %RH Max. (Ta ≤ 40 °C).

(b) Wet-bulb temperature should be 39 °C Max. (Ta > 40 °C).

(c) No condensation.

Note (2) The temperature of panel surface should be 0°C min. and 50 °C max.

Relative Humidity (%RH)

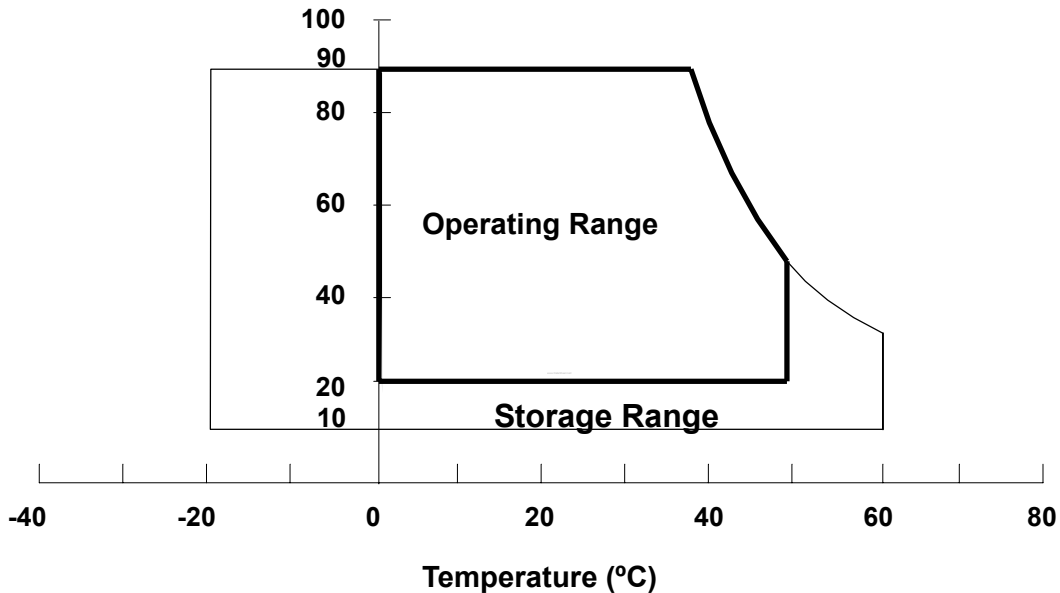

Note (3) 1 time for ± X, ± Y, ± Z. for Condition (200G / 2ms) is half Sine Wave,.

Note (4) 10~200 Hz, 0.5hr/cycle 1cycle for X,Y,Z

Note (5) At testing Vibration and Shock, the fixture in holding the module has to be hard and rigid enough so that the module would not be twisted or bent by the fixture.

The fixing condition is shown as below:

At Room Temperature

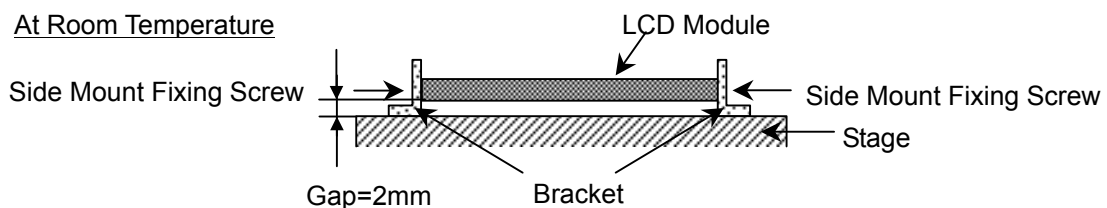

2.2 ELECTRICAL ABSOLUTE RATINGS

2.2.1 TFT LCD MODULE

Item	Symbol	Value		Unit	Note
		Min.	Max.		
Power Supply Voltage	V_{CC}	-0.3	+4.0	V	(1)
Logic Input Voltage	V_{IN}	-0.3	$V_{CC}+0.3$	V	

2.2.2 BACKLIGHT UNIT

Item	Symbol	Value		Unit	Note
		Min.	Max.		
Lamp Voltage	V_L	-	2.5K	V_{RMS}	(1), (2), $I_L = 6.0 \text{ mA}$
Lamp Current	I_L	2	6.5	mA_{RMS}	
Lamp Frequency	F_L	45	80	KHz	(1), (2)

Note (1) Permanent damage to the device may occur if maximum values are exceeded. Function operation should be restricted to the conditions described under Normal Operating Conditions.

Note (2) Specified values are for lamp (Refer to 3.2 for further information).

3. ELECTRICAL CHARACTERISTICS

3.1 TFT LCD MODULE

$T_a = 25 \pm 2 \text{ }^\circ\text{C}$

Parameter	Symbol	Value			Unit	Note	
		Min.	Typ.	Max.			
Power Supply Voltage	V_{CC}	3.0	3.3	3.6	V	-	
Ripple Voltage	V_{RP}	-	100	-	mV	-	
Rush Current	I_{RUSH}	-	-	1.5	A	(2)	
Power Supply Current	White	L_{CC}	-	300	350	mA	(3)a
	Black		-	350	400	mA	(3)b
Logical Input Voltage (LVDS)	"H" Level	V_{IL}	-	-	+100	mV	-
	"L" Level	V_{IH}	-100	-	-	mV	-
Terminating Resistor	R_T	-	100	-	Ohm	-	
Power per EBL WG	P_{EBL}	-	3.224	-	W	(4)	

Note (1) The module should be always operated within above ranges.

Note (2) Measurement Conditions:

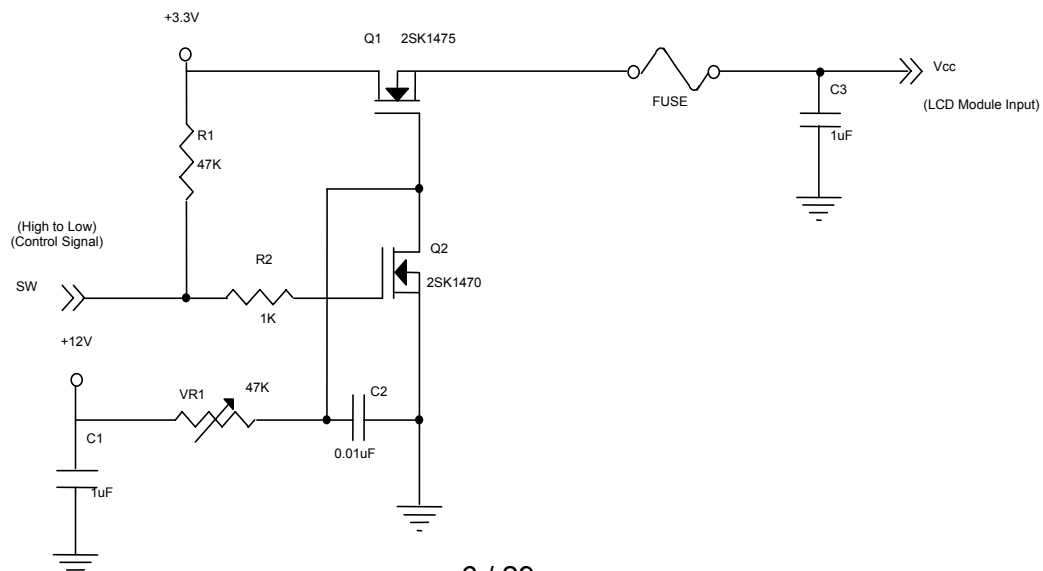

Vcc rising time is 470us

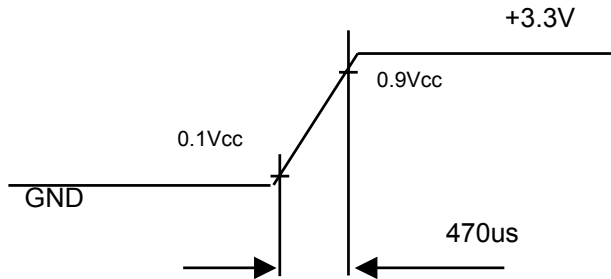

Note (3) The specified power supply current is under the conditions at $V_{cc} = 3.3 \text{ V}$, $T_a = 25 \pm 2 \text{ }^\circ\text{C}$, $f_v = 60 \text{ Hz}$, whereas a power dissipation check pattern below is displayed.

a. White Pattern

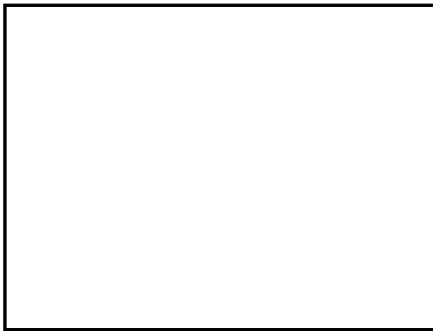

Active Area

b. Black Pattern

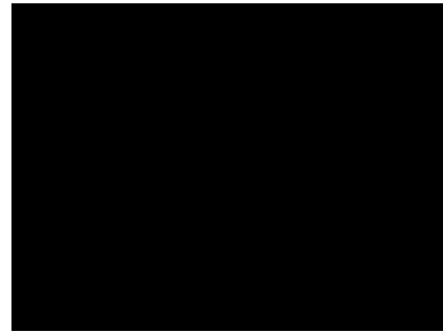

Active Area

Note (4) The specified power are the sum of LCD panel electronics input power and the inverter input power. Test conditions are as follows.

- $V_{cc} = 3.3 \text{ V}$, $T_a = 25 \pm 2 \text{ }^\circ\text{C}$, $f_v = 60 \text{ Hz}$,
- The pattern used is a black and white 32 x 36 checkerboard, slide #100 from the VESA file "Flat Panel Display Monitor Setup Patterns", FPDMSU.ppt.
- Luminance: 60 nits.
- The inverter used is provided from O2Micro (www.o2micro.com). Please contact O2Micro for detail information. CMO doesn't provide the inverter in this product.

3.2 BACKLIGHT UNIT

Ta = 25 ± 2 °C

Parameter	Symbol	Value			Unit	Note
		Min.	Typ.	Max.		
Lamp Input Voltage	V _L	627	660	693	V _{RMS}	I _L = 6.0 mA
Lamp Current	I _L	2.0	6.0	6.5	mA _{RMS}	(1)
Lamp Turn On Voltage	V _s	---	---	1110 (25 °C)	V _{RMS}	(2)
		---	---	1330 (0 °C)		
Operating Frequency	F _L	45	60	80	KHz	(3)
Lamp Life Time	L _{BL}	15,000	---	---	Hrs	(5)
Power Consumption	P _L	---	3.96	---	W	(4), I _L = 6.0 mA

Note (1) Lamp current is measured by utilizing a high frequency current meter as shown below:

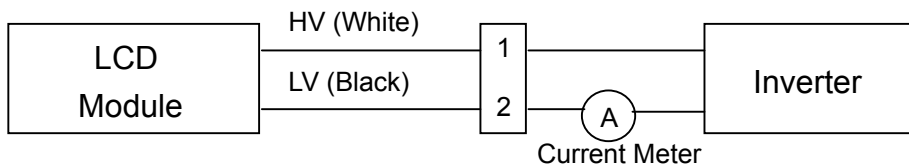

Note (2) The voltage that must be larger than V_s should be applied to the lamp for more than 1 second after startup. Otherwise the lamp may not be turned on.

Note (3) The lamp frequency may produce interference with horizontal synchronous frequency from the display, and this may cause line flow on the display. In order to avoid interference, the lamp frequency should be detached from the horizontal synchronous frequency and its harmonics as far as possible.

Note (4) $P_L = I_L \times V_L$

Note (5) The lifetime of lamp can be defined as the time in which it continues to operate under the condition Ta = 25 ± 2 °C and I_L = 6.0 mA_{RMS} until one of the following events occurs:

- When the brightness becomes or lower than 50% of its original value.
- When the effective ignition length becomes or lower than 80% of its original value. (Effective ignition length is defined as an area that has less than 70% brightness compared to the brightness in the center point.)

Note (6) The waveform of the voltage output of inverter must be area-symmetric and the design of the inverter must have specifications for the modularized lamp. The performance of the Backlight, such as lifetime or brightness, is greatly influenced by the characteristics of the DC-AC inverter for the lamp. All the parameters of an inverter should be carefully designed to avoid producing too much current leakage from high voltage output of the inverter. When designing or ordering the inverter please make sure that a poor lighting caused by the mismatch of the Backlight and the inverter (miss-lighting, flicker, etc.) never occurs. If the above situation is confirmed, the module should be operated in the same manners when it is installed in your instrument.

The output of the inverter must have symmetrical (negative and positive) voltage waveform and symmetrical current waveform. (Unsymmetrical ratio is less than 10%) Please do not use the inverter which has unsymmetrical voltage and unsymmetrical current and spike wave. Lamp frequency may produce interference with horizontal synchronous frequency and as a result this may cause beat on the display. Therefore lamp frequency shall be as away possible from the horizontal synchronous frequency and from its harmonics in order to prevent interference.

Requirements for a system inverter design, which is intended to have a better display performance, a better power efficiency and a more reliable lamp. It shall help increase the lamp lifetime and reduce its leakage current.

- a. The asymmetry rate of the inverter waveform should be 10% below;
- b. The distortion rate of the waveform should be within $\sqrt{2} \pm 10\%$;

The ideal sine wave form shall be symmetric in positive and negative polarities.

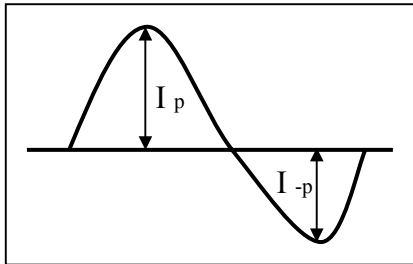

* Asymmetry rate:

$$| I_p - I_{-p} | / I_{rms} * 100\%$$

* Distortion rate

$$I_p \text{ (or } I_{-p}) / I_{rms}$$

3.3 EDID DATA

The following data is based on VESA Enhanced EDID proposal.

Byte #(decimal)	Byte #(hex)	Field Name and Comments	Value(hex)	Value(binary)
0	0	Header	00	00000000
1	1	Header	FF	11111111
2	2	Header	FF	11111111
3	3	Header	FF	11111111
4	4	Header	FF	11111111
5	5	Header	FF	11111111
6	6	Header	FF	11111111
7	7	Header	00	00000000
8	8	EISA ID manufacturer name ("CMO")	0D	00001101
9	9	EISA ID manufacturer name (Compressed ASCII)	AF	10101111
10	0A	ID product code (N150X3-L08)	11	00010001
11	0B	ID product code (hex LSB first; N150X3-L08)	15	00010101
12	0C	ID S/N (fixed "0")	00	00000000
13	0D	ID S/N (fixed "0")	00	00000000
14	0E	ID S/N (fixed "0")	00	00000000
15	0F	ID S/N (fixed "0")	00	00000000
16	10	Week of manufacture (fixed "00H")	00	00000000
17	11	Year of manufacture (fixed "00H")	00	00000000
18	12	EDID structure version # ("1")	01	00000001
19	13	EDID revision # ("3")	03	00000011
20	14	Video I/P definition ("digital")	80	10000000
21	15	Max H image size ("30.4128 cm")	1E	00011110
22	16	Max V image size ("22.8096 cm")	17	00010111
23	17	Display Gamma (Gamma = "2.2")	78	01111000
24	18	Feature support ("Active off, RGB Color")	0A	00001010
25	19	Red/Green (Rx1, Rx0, Ry1, Ry0, Gx1, Gx0, Gy1, Gy0)	77	01110111

26	1A	Blue/White (Bx1, Bx0, By1, By0, Wx1, Wx0, Wy1, Wy0)	F1	11110001
27	1B	Red-x (Rx = "0.626")	A0	10100000
28	1C	Red-y (Ry = "0.355")	5A	01011010
29	1D	Green-x (Gx = "0.294")	4B	01001011
30	1E	Green-y (Gy = "0.589")	96	10010110
31	1F	Blue-x (Bx = "0.144")	24	00100100
32	20	Blue-y (By = "0.097")	18	00011000
33	21	White-x (Wx = "0.309")	4F	01001111
34	22	White-y (Wy = "0.329")	54	01010100
35	23	Established timings 1	00	00000000
36	24	Established timings 2 (1024x768@60Hz)	08	00001000
37	25	Manufacturer's reserved timings	00	00000000
38	26	Standard timing ID # 1	01	00000001
39	27	Standard timing ID # 1	01	00000001
40	28	Standard timing ID # 2	01	00000001
41	29	Standard timing ID # 2	01	00000001
42	2A	Standard timing ID # 3	01	00000001
43	2B	Standard timing ID # 3	01	00000001
44	2C	Standard timing ID # 4	01	00000001
45	2D	Standard timing ID # 4	01	00000001
46	2E	Standard timing ID # 5	01	00000001
47	2F	Standard timing ID # 5	01	00000001
48	30	Standard timing ID # 6	01	00000001
49	31	Standard timing ID # 6	01	00000001
50	32	Standard timing ID # 7	01	00000001
51	33	Standard timing ID # 7	01	00000001
52	34	Standard timing ID # 8	01	00000001
53	35	Standard timing ID # 8	01	00000001
54	36	Detailed timing description # 1 Pixel clock ("65 MHz")	64	01100100

55	37	# 1 Pixel clock (hex LSB first)	19	00011001
56	38	# 1 H active ("1024")	00	00000000
57	39	# 1 H blank ("320")	40	01000000
58	3A	# 1 H active : H blank ("1024 : 320")	41	01000001
59	3B	# 1 V active ("768")	00	00000000
60	3C	# 1 V blank ("38")	26	00100110
61	3D	# 1 V active : V blank ("768 : 38")	30	00110000
62	3E	# 1 H sync offset ("24")	18	00011000
63	3F	# 1 H sync pulse width ("136")	88	10001000
64	40	# 1 V sync offset : V sync pulse width ("3 : 6")	36	00110110
65	41	# 1 H sync offset : H sync pulse width : V sync offset : V sync width ("24 : 136 : 3 : 6")	00	00000000
66	42	# 1 H image size ("304.128 mm")	30	00110000
67	43	# 1 V image size ("228.096 mm")	E4	11100100
68	44	# 1 H image size : V image size ("304 : 228")	10	00010000
69	45	# 1 H boarder ("0")	00	00000000
70	46	# 1 V boarder ("0")	00	00000000
71	47	# 1 Flags ("Non-Interlace, Non-Stereo, Digital Separate")	18	00011000
72	48	Detailed timing description # 2	00	00000000
73	49	# 2 Flag	00	00000000
74	4A	# 2 Reserved	00	00000000
75	4B	# 2 FE (hex) defines ASCII string (Model Name "N150X3", ASCII)	FE	11111110
76	4C	# 2 Flag	00	00000000
77	4D	# 2 1 st character of string ("N")	4E	01001110
78	4E	# 2 2 nd character of string ("1")	31	00110001
79	4F	# 2 3 rd character of string ("5")	35	00110101
80	50	# 2 4 th character of string ("0")	30	00110000
81	51	# 2 5 th character of string ("X")	58	01011000
82	52	# 2 6 th character of string ("3")	33	00110011
83	53	# 2 New line character # 2 indicates end of ASCII string	0A	00001010

84	54	# 2 Padding with "Blank" character	20	00100000
85	55	# 2 Padding with "Blank" character	20	00100000
86	56	# 2 Padding with "Blank" character	20	00100000
87	57	# 2 Padding with "Blank" character	20	00100000
88	58	# 2 Padding with "Blank" character	20	00100000
89	59	# 2 Padding with "Blank" character	20	00100000
90	5A	Detailed timing description # 3	00	00000000
91	5B	# 3 Flag	00	00000000
92	5C	# 3 Reserved	00	00000000
93	5D	# 3 FE (hex) defines ASCII string (Vendor "CMO", ASCII)	FE	11111110
94	5E	# 3 Flag	00	00000000
95	5F	# 3 1 st character of string ("C")	43	01000011
96	60	# 3 2 nd character of string ("M")	4D	01001101
97	61	# 3 3 rd character of string ("O")	4F	01001111
98	62	# 3 New line character # 3 indicates end of ASCII string	0A	00001010
99	63	# 3 Padding with "Blank" character	20	01011000
100	64	# 3 Padding with "Blank" character	20	00100000
101	65	# 3 Padding with "Blank" character	20	00100000
102	66	# 3 Padding with "Blank" character	20	00100000
103	67	# 3 Padding with "Blank" character	20	00100000
104	68	# 3 Padding with "Blank" character	20	00100000
105	69	# 3 Padding with "Blank" character	20	00100000
106	6A	# 3 Padding with "Blank" character	20	00100000
107	6B	# 3 Padding with "Blank" character	20	00100000
108	0A	Detailed timing description # 4	00	00000000
109	6D	# 4 Flag	00	00000000
110	6E	# 4 Reserved	00	00000000
111	6F	# 4 FC (hex) defines Monitor name (Model Name "N150X3-L08", ASCII)	FC	11111100
112	70	# 4 Flag	00	00000000
113	71	# 4 1 st character of name ("N")	4E	01001110

114	72	# 4 2 nd character of name ("1")	31	00110001
115	73	# 4 3 rd character of name ("5")	35	00110101
116	74	# 4 4 th character of name ("0")	30	00110000
117	75	# 4 5 th character of name ("X")	58	01011000
118	76	# 4 6 th character of name ("3")	33	00110011
119	77	# 4 7 th character of name ("-")	2D	00101101
120	78	# 4 8 th character of name ("L")	4C	01001100
121	79	# 4 9 th character of name ("0")	30	00110000
122	7A	# 4 9 th character of name ("8")	38	00111000
123	7B	# 4 New line character # 4 indicates end of ASCII string	0A	00001010
124	7C	# 4 Padding with "Blank" character	20	00100000
125	7D	# 4 Padding with "Blank" character	20	00100000
126	7E	Extension flag	0	00000000
127	7F	Checksum	75	01110101

4. BLOCK DIAGRAM

4.1 TFT LCD MODULE

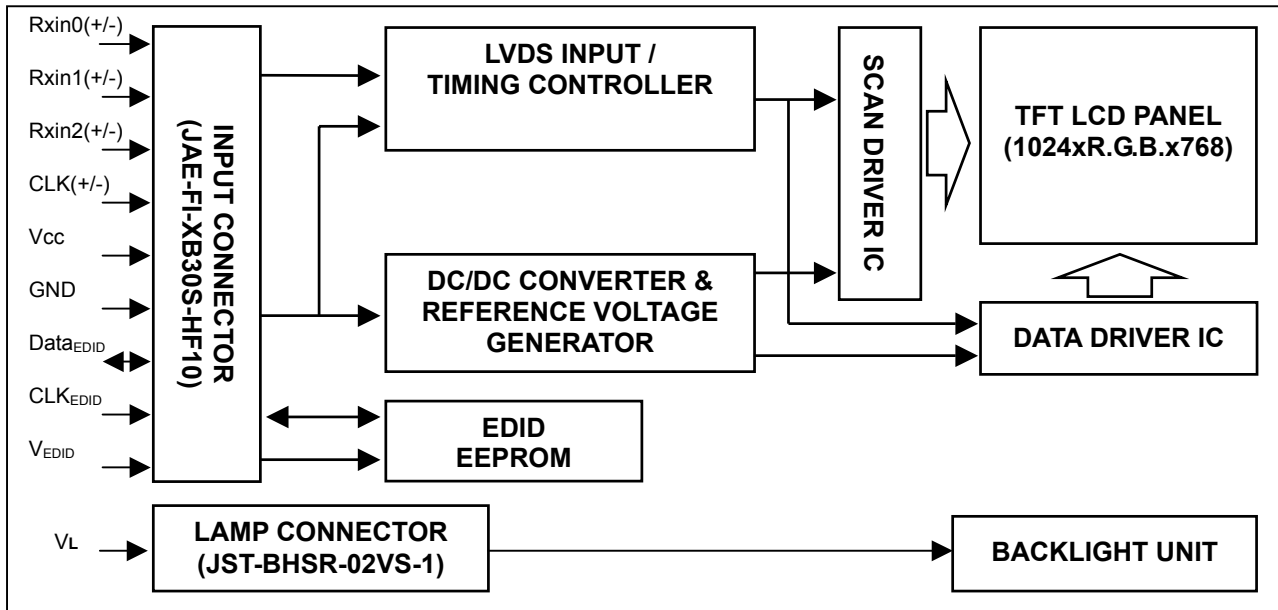

4.2 BACKLIGHT UNIT

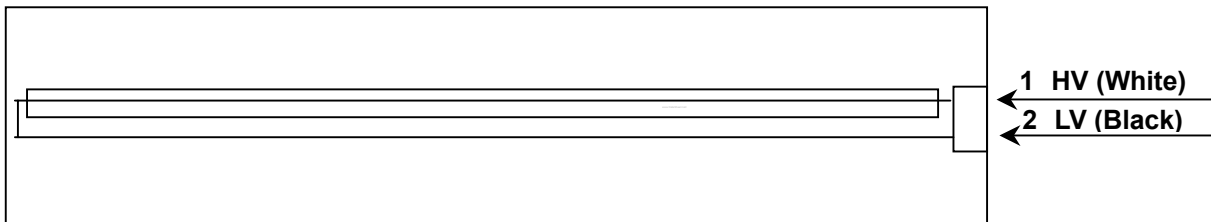

5. INPUT TERMINAL PIN ASSIGNMENT

5.1 TFT LCD MODULE

Pin	Symbol	Description	Polarity	Remark
1	V _{ss}	Ground		
2	V _{cc}	Power Supply +3.3 V (typical)		
3	V _{cc}	Power Supply +3.3 V (typical)		
4	V _{EDID}	DDC 3.3V Power		DDC 3.3V Power
5	NC	Non-Connection		
6	CLK _{EDID}	DDC Clock		DDC Clock
7	DATA _{EDID}	DDC Data		DDC Data
8	Rxin0-	LVDS Differential Data Input	Negative	R0~R5, G0
9	Rxin0+	LVDS Differential Data Input	Positive	-
10	V _{ss}	Ground		
11	Rxin1-	LVDS Differential Data Input	Negative	G1~G5, B0, B1
12	Rxin1+	LVDS Differential Data Input	Positive	-
13	V _{ss}	Ground		
14	Rxin2-	LVDS Differential Data Input	Negative	B2~B5, DE, Hsync, Vsync

15	Rxin2+	LVDS Differential Data Input	Positive	
16	Vss	Ground		
17	CLK-	LVDS Clock Data Input	Negative	LVDS Level Clock
18	CLK+	LVDS Clock Data Input	Positive	
19	Vss	Ground		
20	NC	Non-Connection		
21	NC	Non-Connection		
22	Vss	Ground		
23	NC	Non-Connection		
24	NC	Non-Connection		
25	Vss	Ground		
26	NC	Non-Connection		
27	NC	Non-Connection		
28	Vss	Ground		
29	NC	Non-Connection		
30	NC	Non-Connection		

Note (1) Connector Part No.: JAE-FI-XB30S-HF10 or equivalent

Note (2) User's connector Part No: FI-X30M or equivalent

Note (3) The first pixel is even.

5.2 BACKLIGHT UNIT

Pin	Symbol	Description	Color
1	HV	High Voltage	White
2	LV	Ground	Black

Note (1) Connector Part No.: JST- BHSR-02VS-1 or equivalent

Note (2) User's connector Part No.: SM02B-BHSS-1-TB or equivalent

5.3 TIMING DIAGRAM OF LVDS INPUT SIGNAL

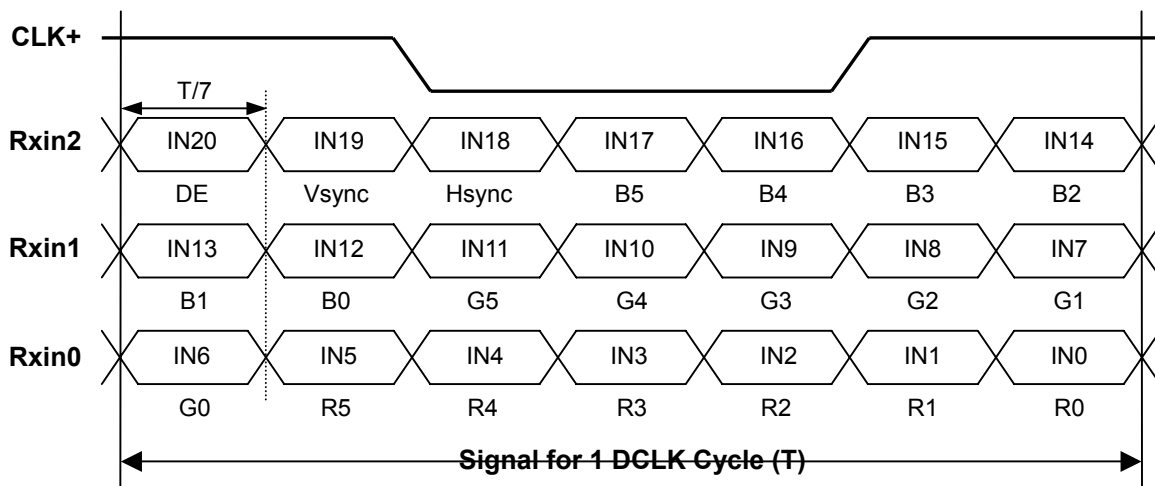

5.4 COLOR DATA INPUT ASSIGNMENT

The brightness of each primary color (red, green and blue) is based on the 6-bit gray scale data input for the color. The higher the binary input, the brighter the color. The table below provides the assignment of color versus data input.

Color		Data Signal																	
		Red						Green						Blue					
		R5	R4	R3	R2	R1	R0	G5	G4	G3	G2	G1	G0	B5	B4	B3	B2	B1	B0
Basic Colors	Black	0	0	0	0	0	0	0	0	0	0	0	0	0	0	0	0	0	0
	Red	1	1	1	1	1	1	0	0	0	0	0	0	0	0	0	0	0	0
	Green	0	0	0	0	0	0	1	1	1	1	1	1	0	0	0	0	0	0
	Blue	0	0	0	0	0	0	0	0	0	0	0	0	1	1	1	1	1	1
	Cyan	0	0	0	0	0	0	1	1	1	1	1	1	1	1	1	1	1	1
	Magenta	1	1	1	1	1	1	0	0	0	0	0	0	1	1	1	1	1	1
	Yellow	1	1	1	1	1	1	1	1	1	1	1	1	0	0	0	0	0	0
	White	1	1	1	1	1	1	1	1	1	1	1	1	1	1	1	1	1	1
Gray Scale Of Red	Red(0)/Dark	0	0	0	0	0	0	0	0	0	0	0	0	0	0	0	0	0	0
	Red(1)	0	0	0	0	0	1	0	0	0	0	0	0	0	0	0	0	0	0
	Red(2)	0	0	0	0	1	0	0	0	0	0	0	0	0	0	0	0	0	0
	:	:	:	:	:	:	:	:	:	:	:	:	:	:	:	:	:	:	:
	:	:	:	:	:	:	:	:	:	:	:	:	:	:	:	:	:	:	:
	:	:	:	:	:	:	:	:	:	:	:	:	:	:	:	:	:	:	:
	Red(61)	1	1	1	1	0	1	0	0	0	0	0	0	0	0	0	0	0	0
	Red(62)	1	1	1	1	1	0	0	0	0	0	0	0	0	0	0	0	0	0
Red(63)	1	1	1	1	1	1	0	0	0	0	0	0	0	0	0	0	0	0	
Gray Scale Of Green	Green(0)/Dark	0	0	0	0	0	0	0	0	0	0	0	0	0	0	0	0	0	0
	Green(1)	0	0	0	0	0	0	0	0	0	0	0	1	0	0	0	0	0	0
	Green(2)	0	0	0	0	0	0	0	0	0	0	1	0	0	0	0	0	0	0
	:	:	:	:	:	:	:	:	:	:	:	:	:	:	:	:	:	:	:
	:	:	:	:	:	:	:	:	:	:	:	:	:	:	:	:	:	:	:
	:	:	:	:	:	:	:	:	:	:	:	:	:	:	:	:	:	:	:
	Green(61)	0	0	0	0	0	0	1	1	1	1	0	1	0	0	0	0	0	0
	Green(62)	0	0	0	0	0	0	1	1	1	1	1	0	0	0	0	0	0	0
Green(63)	0	0	0	0	0	0	1	1	1	1	1	1	0	0	0	0	0	0	
Gray Scale Of Blue	Blue(0)/Dark	0	0	0	0	0	0	0	0	0	0	0	0	0	0	0	0	0	0
	Blue(1)	0	0	0	0	0	0	0	0	0	0	0	0	0	0	0	0	0	1
	Blue(2)	0	0	0	0	0	0	0	0	0	0	0	0	0	0	0	0	1	0
	:	:	:	:	:	:	:	:	:	:	:	:	:	:	:	:	:	:	:
	:	:	:	:	:	:	:	:	:	:	:	:	:	:	:	:	:	:	:
	:	:	:	:	:	:	:	:	:	:	:	:	:	:	:	:	:	:	:
	Blue(61)	0	0	0	0	0	0	0	0	0	0	0	0	1	1	1	1	0	1
	Blue(62)	0	0	0	0	0	0	0	0	0	0	0	0	1	1	1	1	1	0
Blue(63)	0	0	0	0	0	0	0	0	0	0	0	0	1	1	1	1	1	1	

Note (1) 0: Low Level Voltage, 1: High Level Voltage

6. INTERFACE TIMING

6.1 INPUT SIGNAL TIMING SPECIFICATIONS

The specifications of input signal timing are as the following table and timing diagram.

Signal	Item	Symbol	Min.	Typ.	Max.	Unit	Note
DCLK	Frequency	1/Tc	50	65	68	MHz	-
DE	Vertical Total Time	TV	771	806	850	TH	-
	Vertical Addressing Time	TVD	768	768	768	TH	-
	Horizontal Total Time	TH	1200	1344	1500	Tc	-
	Horizontal Addressing Time	THD	1024	1024	1024	Tc	-

INPUT SIGNAL TIMING DIAGRAM

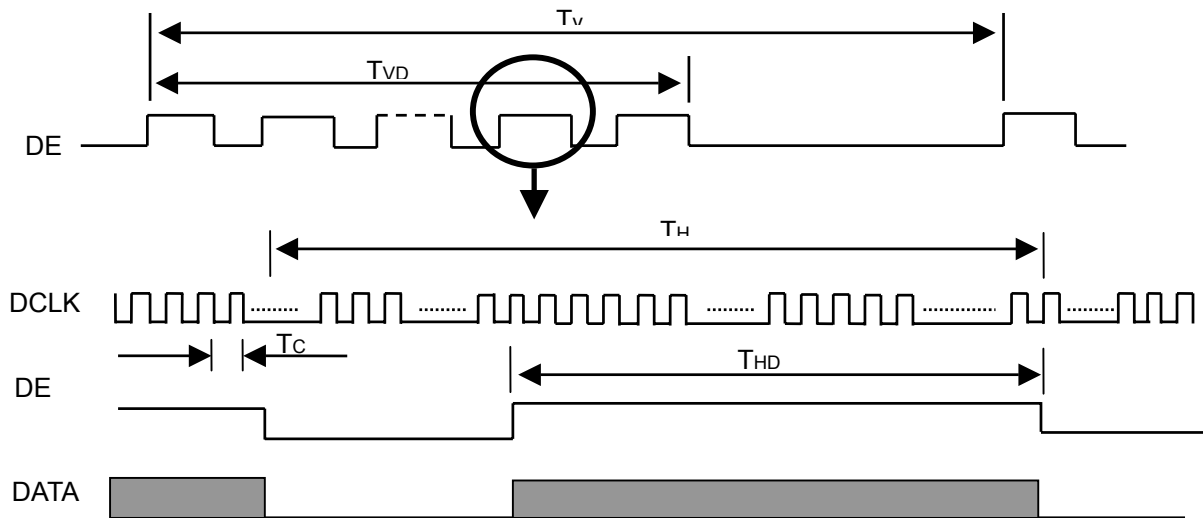

6.2 POWER ON/OFF SEQUENCE

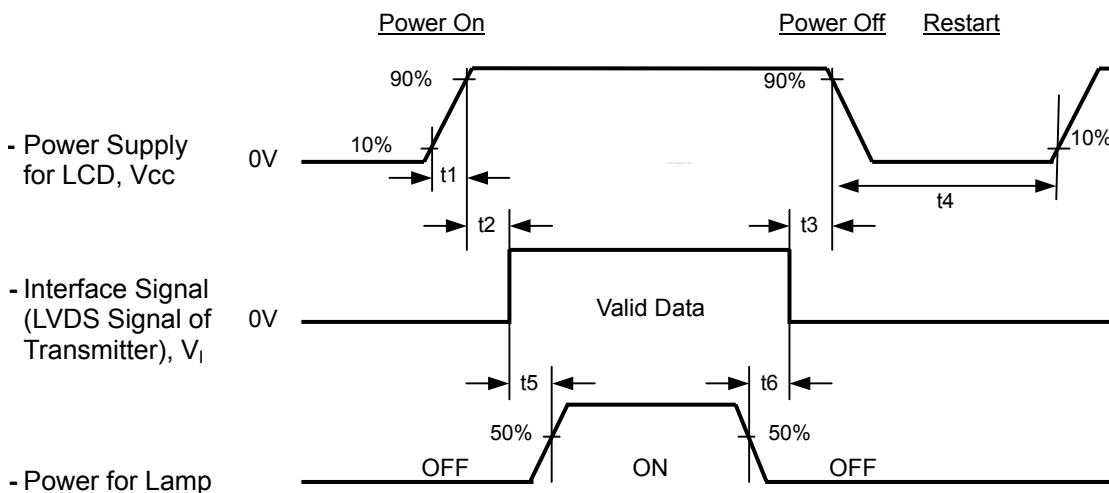

Timing Specifications:

- $0 < t_1 \leq 10 \text{ msec}$
- $0 < t_2 \leq 50 \text{ msec}$
- $0 < t_3 \leq 50 \text{ msec}$
- $t_4 \geq 500 \text{ msec}$
- $t_5 \geq 200 \text{ msec}$
- $t_6 \geq 200 \text{ msec}$

Note (1) Please avoid floating state of interface signal at invalid period.

Note (2) When the interface signal is invalid, be sure to pull down the power supply of LCD V_{cc} to 0 V.

Note (3) The Backlight inverter power must be turned on after the power supply for the logic and the interface signal is valid. The Backlight inverter power must be turned off before the power supply for the logic and the interface signal is invalid.

7. OPTICAL CHARACTERISTICS

7.1 TEST CONDITIONS

Item	Symbol	Value	Unit
Ambient Temperature	T _a	25±2	°C
Ambient Humidity	H _a	50±10	%RH
Supply Voltage	V _{CC}	3.3	V
Input Signal	According to typical value in "3. ELECTRICAL CHARACTERISTICS"		
Inverter Current	I _L	6.0	mA
Inverter Driving Frequency	F _L	61	KHz
Inverter	H05-4915		

The relative measurement methods of optical characteristics are shown in 6.2. The following items should be measured under the test conditions described in 6.1 and stable environment shown in Note (6).

7.2 OPTICAL SPECIFICATIONS

Item		Symbol	Condition	Min.	Typ.	Max.	Unit	Note
Color Chromaticity	Red	R _x	$\theta_x=0^\circ, \theta_y=0^\circ$ CS-1000T	TYP -0.03	0.599	TYP +0.03	---	(1), (5)
		R _y			0.344		---	
	Green	G _x			0.307		---	
		G _y			0.534		---	
	Blue	B _x			0.152		---	
		B _y			0.129		---	
	White	W _x			0.313		---	
		W _y			0.329		---	
Center Luminance of White		L _c		170	200	---	cd/m ²	(4), (5)
Contrast Ratio		CR		250	350	---	---	(2), (5)
Response Time		T _r	$\theta_x=0^\circ, \theta_y=0^\circ$	---	5	10	ms	(3)
		T _f		---	11	16	ms	
White Variation		δW	$\theta_x=0^\circ, \theta_y=0^\circ$ CA-210	---	1.25	1.40	%	(6)
Viewing Angle	Horizontal	θ_{x+}	CR≥10 CA-210	40	45	---	Deg.	(1), (5)
		θ_{x-}		40	45	---		
	Vertical	θ_{y+}		15	20	---		
		θ_{y-}		40	45	---		

Note (1) Definition of Viewing Angle (θ_x, θ_y):

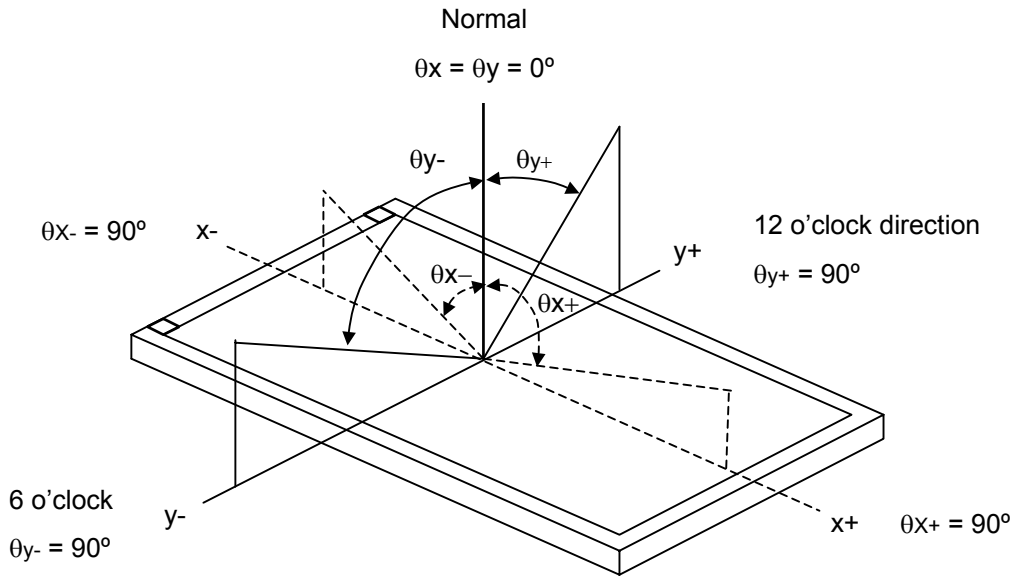

Note (2) Definition of Contrast Ratio (CR):

The contrast ratio can be calculated by the following expression.

$$\text{Contrast Ratio (CR)} = L_{63} / L_0$$

L63: Luminance of gray level 63

L 0: Luminance of gray level 0

$$\text{CR} = \text{CR} (5)$$

CR (X) is corresponding to the Contrast Ratio of the point X at Figure in Note (6).

Note (3) Definition of Response Time (T_R, T_F):

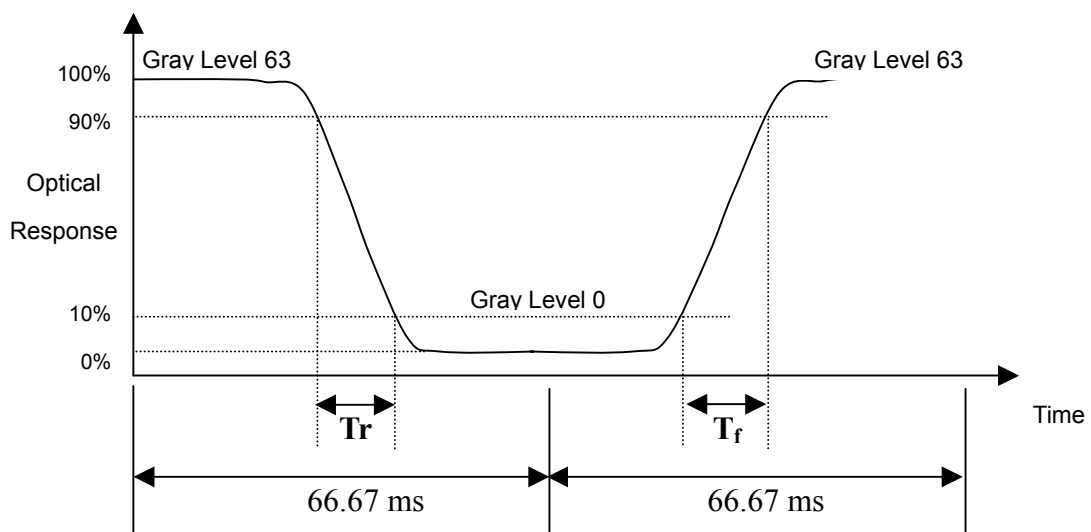

Note (4) Definition of Luminance of White (L_c):

Measure the luminance of gray level 63 at 5 points

$L_c = L(5)$

$L(x)$ is corresponding to the luminance of the point X at Figure in Note (6).

Note (5) Measurement Setup:

The LCD module should be stabilized at given temperature for 15 minutes to avoid abrupt temperature change during measuring. In order to stabilize the luminance, the measurement should be executed after lighting Backlight for 20 minutes in a windless room.

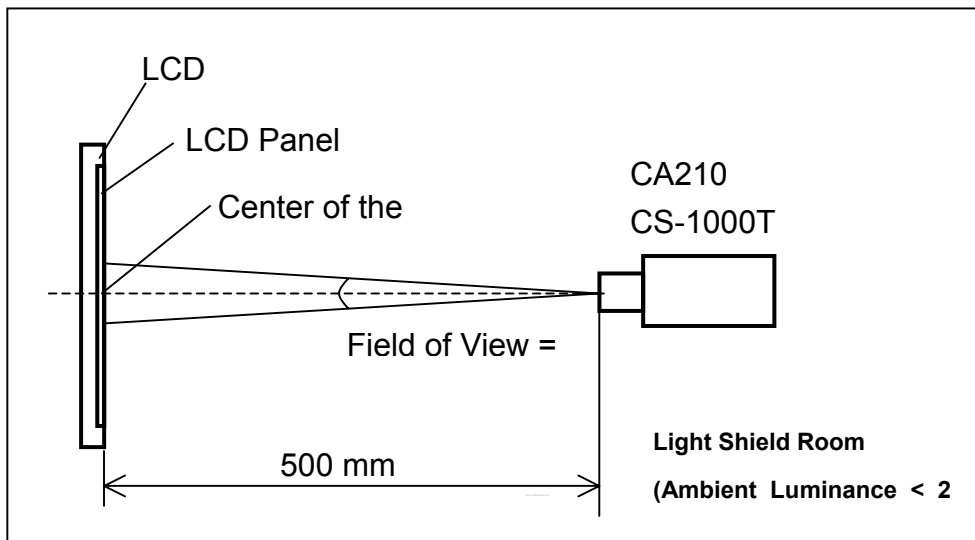

Note (6) Definition of White Variation (δW):

Measure the luminance of gray level 63 at 5 points

$\delta W = \text{Maximum} [L(1), L(2), L(3), L(4), L(5)] / \text{Minimum} [L(1), L(2), L(3), L(4), L(5)]$

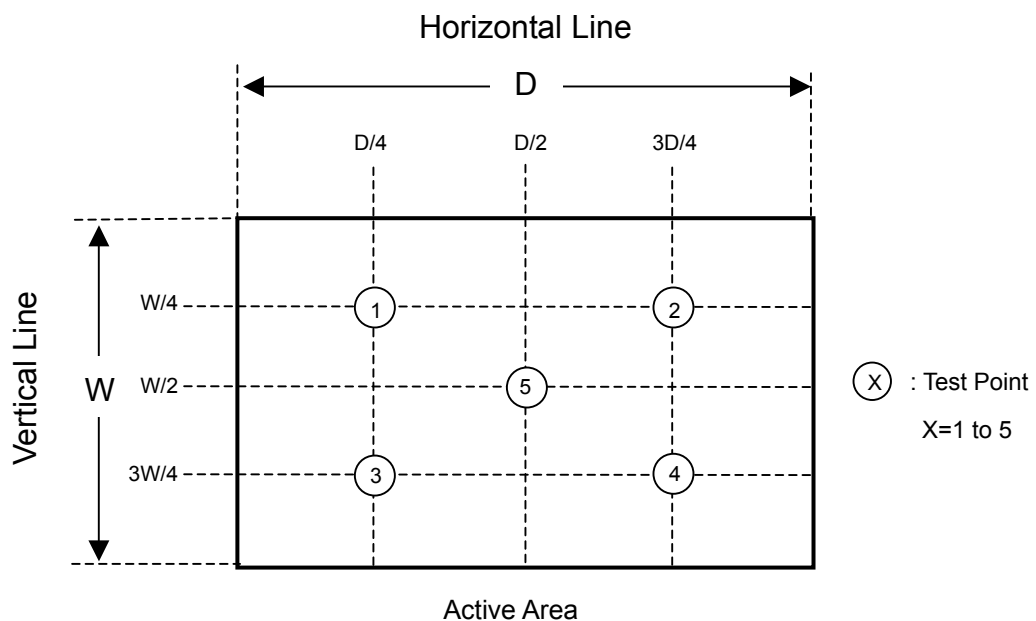

8. PRECAUTIONS

8.1 ASSEMBLY AND HANDLING PRECAUTIONS

- (1) Do not apply rough force such as bending or twisting to the module during assembly.
- (2) To assemble or install module into user's system can be only in clean working areas. The dust and oil may cause electrical short or worsen the polarizer.
- (3) It's not permitted to have pressure or impulse on the module because the LCD panel and Backlight will be damaged.
- (4) Always follow the correct power sequence when LCD module is connecting and operating. This can prevent damage to the CMOS LSI chips during latch-up.
- (5) Do not pull the I/F connector in or out while the module is operating.
- (6) Do not disassemble the module.
- (7) Use a soft dry cloth without chemicals for cleaning, because the surface of polarizer is very soft and easily scratched.
- (8) It is dangerous that moisture come into or contacted the LCD module, because moisture may damage LCD module when it is operating.
- (9) High temperature or humidity may reduce the performance of module. Please store LCD module within the specified storage conditions.
- (10) When ambient temperature is lower than 10°C may reduce the display quality. For example, the response time will become slowly, and the starting voltage of CCFL will be higher than room temperature.

8.2 SAFETY PRECAUTIONS

- (1) The startup voltage of Backlight is approximately 1000 Volts. It may cause electrical shock while assembling with inverter. Do not disassemble the module or insert anything into the Backlight unit.
- (2) If the liquid crystal material leaks from the panel, it should be kept away from the eyes or mouth. In case of contact with hands, skin or clothes, it has to be washed away thoroughly with soap.
- (3) After the module's end of life, it is not harmful in case of normal operation and storage.

9. DEFINITION OF LABELS

9.1 CMO MODULE LABEL

The barcode nameplate is pasted on each module as illustration, and its definitions are as following explanation.



- (a) Model Name: N150X3 - L08
- (b) Revision: Rev. XX: ES : A1, A2, A3, ..., etc.
 CS & MP : C1, C2, C3, ..., etc.

Note: It will happen that revision code changed without product changed in developing duration because of CMO internal stage change, for example: AX → B1, BX → C1.

- (c) Serial ID: XXXXXXXXYMDLNNNN
 - Serial No.
 - Product Line
 - Year, Month, Date
 - CMO Internal Use
 - Revision
 - CMO Internal Use

Serial ID includes the information as below:

- (a) Manufactured Date: Year: 0 ~ 9, for 2000 ~ 2009.
 Month: 1 ~ 9, A ~ C, for Jan. ~ Dec.
 Day: 1 ~ 9, A ~ Y, for 1st to 31st, exclude I, O and U.
- (b) Revision Code: cover all the changes.
- (c) Serial No.: Manufacturing sequence of product.
- (d) Product Line: 1 -> Line1, 2 -> Line 2, ...etc.

9.2 CMO CARTON LABEL

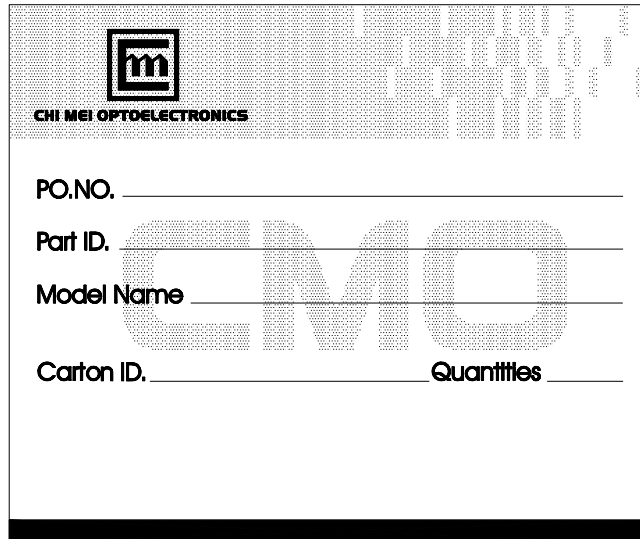

The image shows a template for a CMO carton label. It features a header with the CHI MEI logo and the text "CHI MEI OPTOELECTRONICS". Below the header, there are four lines of text, each followed by a horizontal line for input: "PO.NO.", "Part ID.", "Model Name", and "Carton ID.". The word "CMO" is printed in large, light letters in the background. To the right of the "Carton ID." line, the word "Quantities" is printed. The label has a black bar at the bottom.

10.PACKING
10.1 CARTON

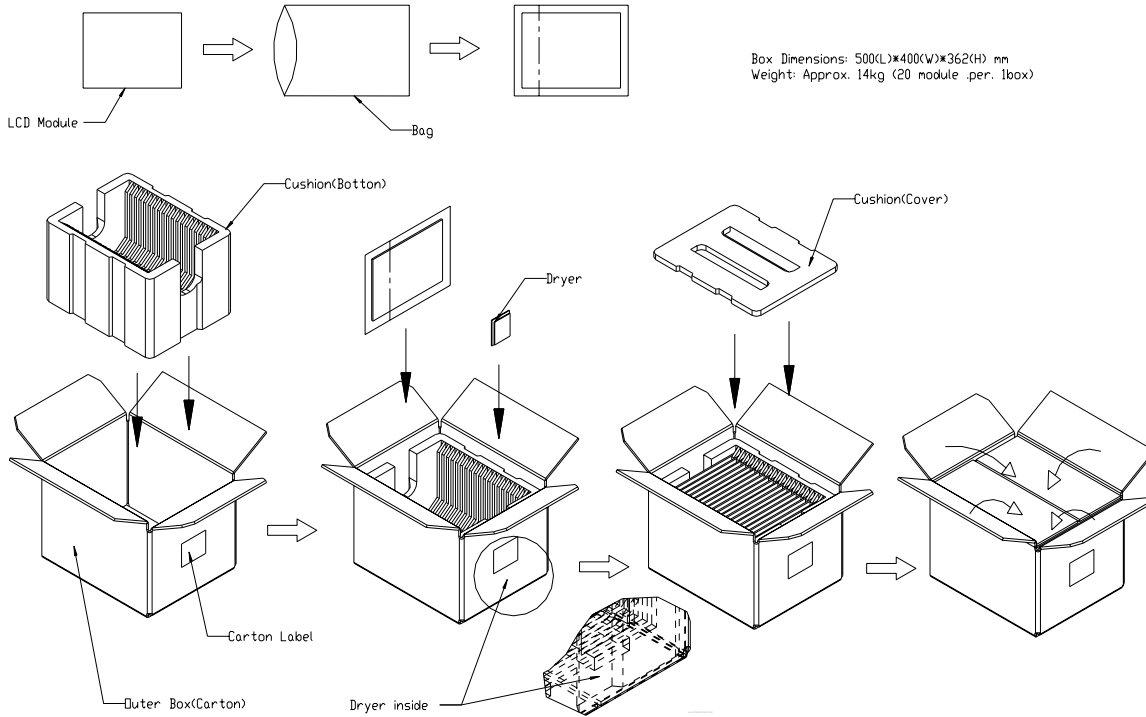

10.2 PALLET

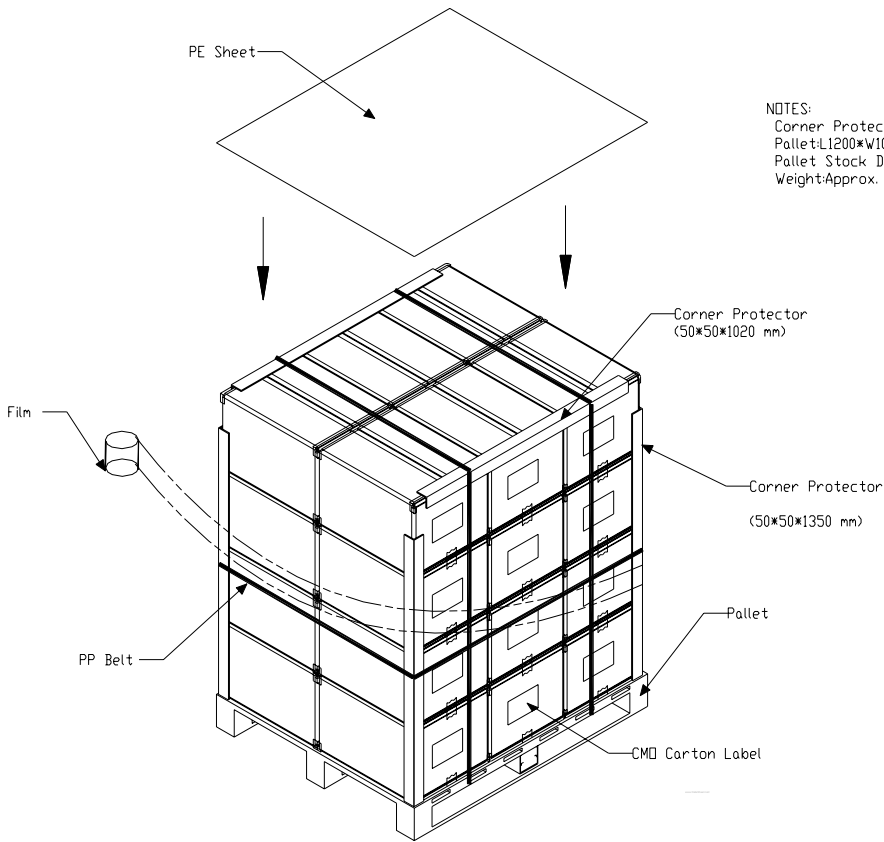

NOTES:
Corner Protector:L1350mm*50mm*50mm
Pallet:L1200*W1000*H135mm
Pallet Stock Dim:L1200*W1000*H1583mm
Weight:Approx. 356 kg

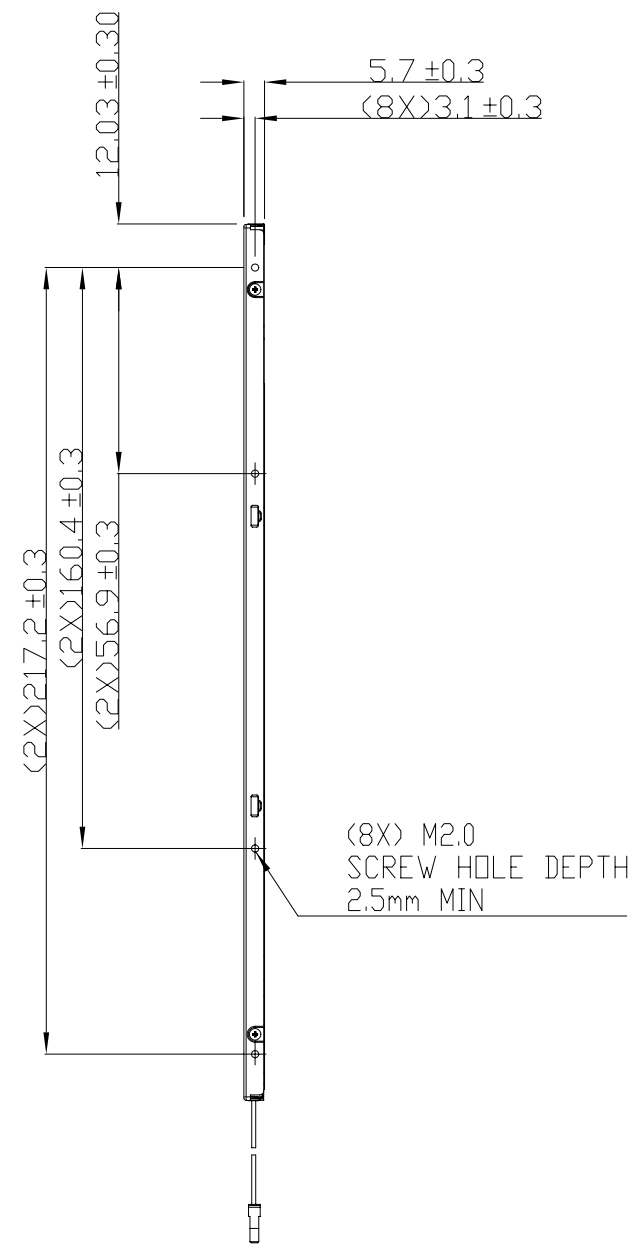
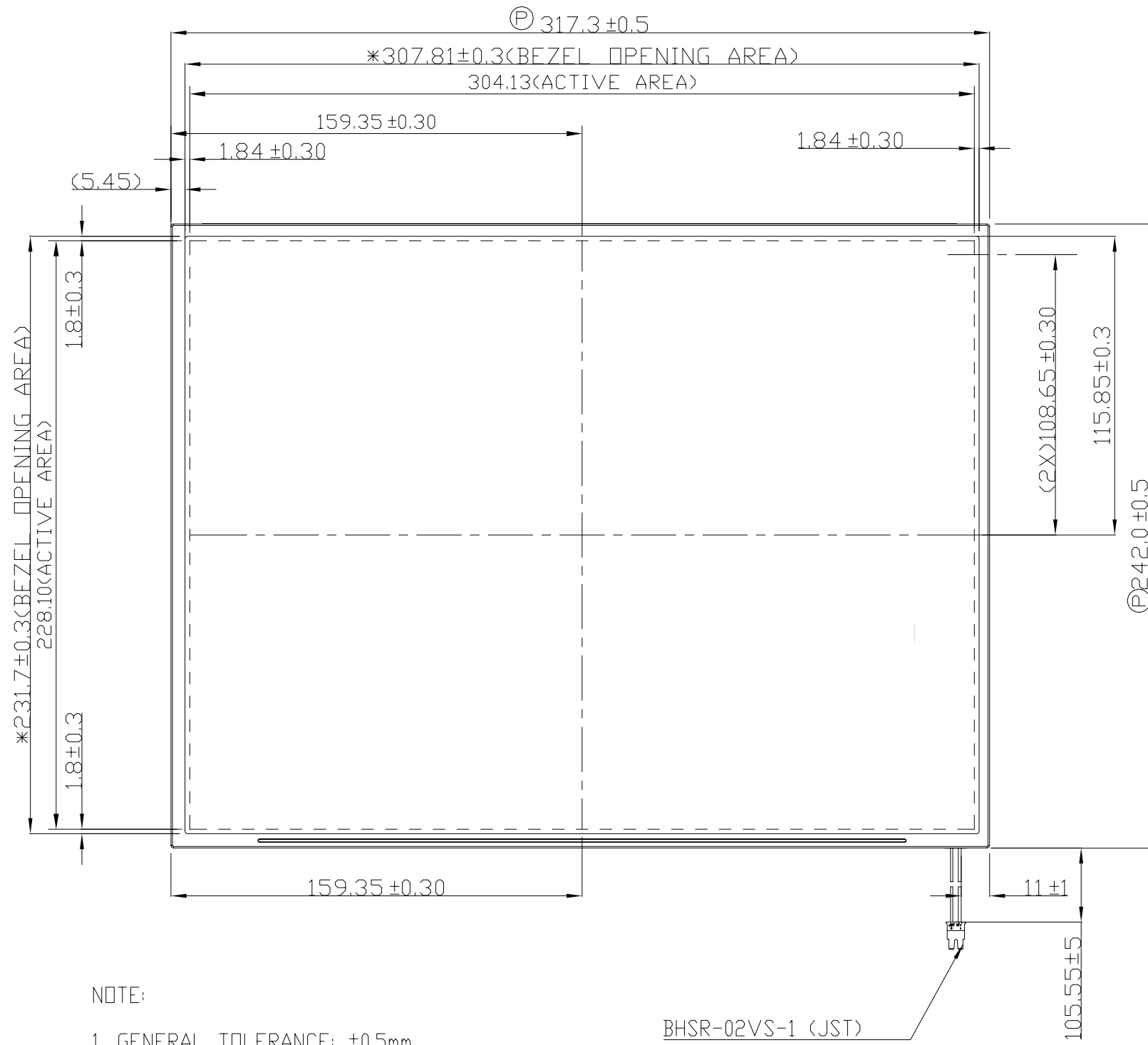

TITLE	OUTLINE N150X3-L08 DRAWING			2D REV.	B
				3D REV.	N/A
Approved	Cliff Tsai	Drawing No.	N15044112B		
Checked	Minchang Chen	Part No.	NF0X308901		
Drawer	Boris	Material	N/A	Sheet	1/2 A3
Designer	Shunnan	Date	27/OCT/2005	Scale	1:1 Unit:mm

CHI MEI ALL RIGHTS RESERVED, COPYING FORBIDDEN.
 OPTOELECTRONICS CORP.

Mark	Description	Date	Changed_By	Approved_By	ECN No.	Remark
1						
2						
3						
4						

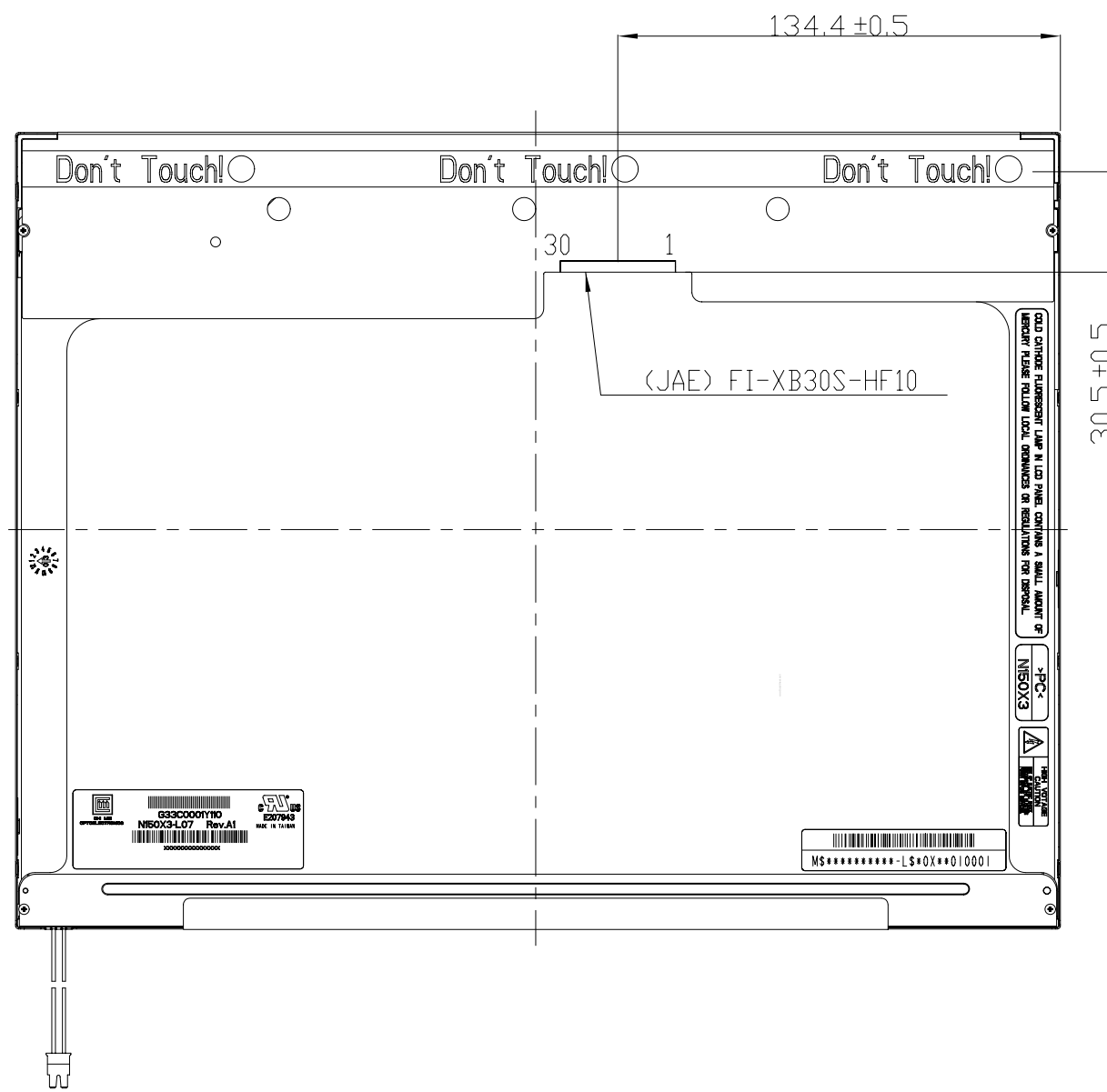

TITLE	OUTLINE N150X3-L08 DRAWING			2D REV.	B
				3D REV.	N/A
Approved	Cliff Tsai	Drawing No.	N15044112B		
Checked	Minchang Chen	Part No.	NF0X308901		
Drawer	Boris	Material	N/A	Sheet	2/2 A3
Designer	Shunnan	Date	27/OCT/2005	Scale	1:1 Unit:mm



CHI MEI ALL RIGHTS RESERVED, COPYING FORBIDDEN.
OPTOELECTRONICS CORP.

Mark	Description	Date	Changed_By	Approved_By	ECN No.	Remark
1						
2						
3						
4						